

**The Project Gutenberg eBook of Scientific American Supplement,
No. 520, December 19, 1885, by Various**

This ebook is for the use of anyone anywhere in the United States and most other parts of the world at no cost and with almost no restrictions whatsoever. You may copy it, give it away or re-use it under the terms of the Project Gutenberg License included with this ebook or online at www.gutenberg.org. If you are not located in the United States, you'll have to check the laws of the country where you are located before using this eBook.

Title: Scientific American Supplement, No. 520, December 19, 1885

Author: Various

Release date: September 8, 2004 [EBook #13401]
Most recently updated: December 18, 2020

Language: English

Credits: Produced by Juliet Sutherland, Don Kretz, and the Online Distributed Proofreading Team.

*** START OF THE PROJECT GUTENBERG EBOOK SCIENTIFIC AMERICAN
SUPPLEMENT, NO. 520, DECEMBER 19, 1885 ***



**SCIENTIFIC AMERICAN
SUPPLEMENT NO. 520**

NEW YORK, DECEMBER 19, 1885

Scientific American Supplement. Vol. XX, No. 520.

Scientific American established 1845

Scientific American Supplement, \$5 a year.

Scientific American and Supplement, \$7 a year.

TABLE OF CONTENTS.

- I. [ENGINEERING, ETC.—Steel Structures.—Best use of different grades of steel.—From a paper by Mr. JAS. CHRISTIE.](#)
[Natural Gas Fuel and its Application to Manufacturing: Purposes.—Paper read before the Iron and Steel Institute by Mr. ANDREW CARNEGIE.—First use of the gas.—Wells near Pittsburg.—Extent of territory underlain with gas.—Cost of piping.—Analyses of natural gas.](#)
[A Gas Engine Water Supply Alarm.—1 figure.](#)
[The Water Supply of Ancient Roman Cities.—An address by Prof. W.H. CORFIELD.—Aqueducts for the supply of Borne.—The aqueduct bridge Pont du Gard.—The supply of Lyons.—Construction of underground aqueducts.](#)
[Steam Engine Economy.—By Chief Engineer J. LOWE, U.S.N.—With diagram.](#)
[The "Elastic Limit" in Metals.—Selection of wire for suspension bridges, etc.](#)
[Prices of Metals in 1874 and 1884.—With table.](#)
- II. [TECHNOLOGY.—A Method of Measuring the Absolute Sensitiveness of Photographic Dry Plates.—By Wm. H. PICKERING.—From the proceedings of](#)

- [the Academy of Arts and Sciences.](#)
- [Soldering and Repairing Platinum Vessels in the Laboratory.—By J.W. PRATT.](#)
- [The Helicoidal or Wire Stone Saw invented by M.P. GAY.—With engraving of quarry showing application of saw, and 5 figures.](#)
- [Portable Prospecting Drill and Automatic Safety Gear shown at the Inventions Exhibition.—With 2 engravings.](#)
- III. [ELECTRICITY, ETC.—Electricity in Warfare.—By Lieutenant B.A. FISKE, U.S.N.—Electrical torpedoes.—Torpedo detector.—Military telegraphy and telephony.—Electricity for firing great guns.—Arrangement of wires for lights.—The search light.—Incandescent lamps for sight signaling.—Electrical launches.—An "electric sight".](#)
- [Meucci's Claims to the Telephone.—With description of his instrument and 10 figures.](#)
- [An Electric Centrifugal Machine for Laboratories.—By ALEX. WATT.—From paper read before the British Association.—1 figure.](#)
- [Transmission of Power by Electricity.—Experiments of M. MARCEL DEPREZ.](#)
- IV. [ART AND ARCHITECTURE.—Quadriga for the New House of Parliament at Vienna.—An engraving.](#)
- [Glazed Ware Finial.—With engraving.](#)
- [Hotel de Ville, St. Quentin.—With engraving.](#)
- [Fire Doors in Mills.—From a lecture before the Franklin Institute by C.J. HEXAMER.](#)
- V. [NATURAL HISTORY, ETC.—Preservation of Insects.](#)
- [An Accomplished Parrot.](#)
- [The Roscoff Zoological Laboratory.—The buildings and rooms.—The aquarium.—Course of study.](#)
- [The Murænae at the Berlin Aquarium.—With engraving.](#)
- [Metamorphosis of Arctic Insects.](#)
- VI. [MEDICINE, ETC.—A Year's Scientific Progress in Nervous and Mental Diseases.—By Prof. L.A. MERRIAM.—Report to the Nebraska State Medical Society.](#)
- [Scaring the Baby Out.](#)
- VII. [MISCELLANEOUS.—Wage Earners and their Houses.—Manufacturers as landlords.—Experiments of Pullman, Owen, Peabody, and others.](#)
- [The Locked and Corded Box Trick, with Directions for making the Box.—By D B. ADAMSON.—9 figures.](#)
- [A Perpetual Calendar.—With engraving.](#)

PRESERVATION OF INSECTS.

To remove the verdigris which forms upon the pins, the pinned insects should be immersed in benzine and left there for a time; several hours is generally long enough. The administration of this bath cannot be too highly recommended for beetles which have been rendered unrecognizable by grease, especially when dust has been mixed with the grease. This immersion, of variable duration according to circumstances, will restore to these insects, however bad they have become, all their brilliancy and all their first freshness, and the efflorescences of cupric oxide will not reappear. This preventive and curative method is also readily applicable to beetles glued upon paper which have become greasy; plunge them into benzine in the same way, and as the gum is insoluble in the liquid, they remain fastened to their supports. Pruinose beetles, which are few in number, are the only ones that benzine can alter; the others, which are glabrous, pubescent, or scaly, can only gain by the process, and they will always make a good show in the collection.—*A. Dubois in Feuille des jeunes naturalistes*, March, 1885, p. 71.—*Psyche*.

QUADRIGA FOR THE NEW HOUSE OF PARLIAMENT, AT VIENNA.



QUADRIGA FOR THE NEW HOUSE OF PARLIAMENT, AT VIENNA.

The new House of Parliament at Vienna is known as one of the finest specimens of pure Greek architecture erected in this century; and throughout the entire building great pains have been taken to ornament the same as elaborately as is consistent with good taste. The main buildings are provided with corner pavilions, the atticas of which project over the roofs, and these atticas and other parts of the buildings are to be surmounted by quadrigas, one of which is shown in the annexed cut, taken from the *Illustrirte Zeitung*. This group was modeled by V. Pilz, of Vienna, and represents a winged goddess in a chariot drawn by four spirited steeds harnessed abreast. She holds a wreath in her raised right hand, and her left hand is represented as holding the lines for guiding the horses. The group is full of expression and life, and will add greatly to the beauty of the building to be surmounted by it.

The strongest wood in the United States, according to Professor Sargent, is that of the nutmeg hickory of the Arkansas region, and the weakest the West Indian birch (*Rur seva*). The most elastic is the tamarack, the white or shellbark hickory standing far below it. The least elastic and the lowest in specific gravity is the wood of the *Ficus aurea*. The highest specific gravity, upon which in general depends value as fuel, is attained by the bluewood of Texas (*Condalia obovata*).

GLAZED WARE FINIAL.



GLAZED WARE FINIAL.

This grand 16th century finial is a fine example of French ceramic ware, or glazed terracotta, and it is illustrated both by geometrical elevation and a cross sectional drawing. This latter shows the clever building up of the structure by means of a

series of five pieces, overlapping each other, and kept rigid by means of a stout wrought-iron upright in the center, bolted on to the ridge, and strapped down on the hip pieces. Its outline is well designed for effect when seen at a distance or from below, and its glazed surface heightens the artistic colorings, giving it a brilliant character in the sunlight, as well as protecting the ware from the action of smoke and weather.—*Build. News.*

WAGE EARNERS AND THEIR HOUSES.

MANUFACTURERS AS LANDLORDS.

Among the more prominent movements of the day for the improvement of the condition of the working men are those which are growing into fashion with large manufacturing incorporations. Their promise lies immediately in the fact that they call for no new convictions of political economy, and hence have nothing disturbing or revolutionary about them. Accepting the usages and economical principles of industrial life, as the progress of business has developed them, an increasing number of large manufacturers have deemed it to their interest not only to furnish shops and machinery for their operatives, but dwellings as well, and in some instances the equipments of village life, such as schools, chapels, libraries, lecture and concert halls, and a regime of morals and sanitation. Probably the most expensive investment of this sort in the United States, if not in the world, by any single company, is that of Pullman, on Lake Calumet, a few miles south of Chicago, an enterprise as yet scarcely five years old. It is by no means a novel undertaking, except in the magnitude, thoroughness, and unity of the scheme. Twenty years ago the managers of the Lonsdale Mills, in Rhode Island, were erecting cottages on a uniform plan and maintaining schools and religious services for their operatives. More recent but more extensive is the village of the Ponemah Cotton Mill, near Taftville, Conn. These are illustrations merely of similar investments upon a smaller scale elsewhere. But the European examples are older, such as Robert Owen's experiment at New Lanark in Scotland, Saltaire in Yorkshire, Dollfuss' Mulhausen Quarter in Alsace, and M. Godin's community in the French village of Guise, which are among the more familiar instances of investments originally made on business principles, with a view to the improved conditions of workmen. New Lanark failed as a commercial community through the visionary character of its founder; the Godin works at Guise have passed into the co-operative phase within the past five years, but Saltaire and Mulhausen still retain their proprietary business features.

The class of ventures of which these instances are but the more conspicuous examples has peculiar characteristics. They differ from the Peabody and Waterlow buildings of London, described in *Bradstreet's* last August, from Starr's Philadelphia dwellings, and from the operations of the "Improved Dwellings Association" of New York in these particulars: the latter are financially a pure question of direct investment; are mainly concerned with life among the poor of cities, and, whatever philanthropy may be in their motive, are capable of adaptation to any class of citizens. The former, while investments also, are composite, the business of manufacturing being associated with that of rent collecting and sharing its profits and losses; their field of operations is almost invariably rural, and tenancy is restricted to the employes of the proprietor. On the other hand, they differ from all co-operative and socialistic communities in that they are an adaptation to existing circumstances, propose to demonstrate no new theories of economics, are free from all religious bonds, do not depend on any unity of opinion, and do not touch the question of the proper distribution of wealth.

It is, of course, no new thing for owners of large factories, particularly in country districts, to furnish tenements for their operatives, and oftentimes it is quite indispensable that they should, because there would otherwise be no accommodation for their workmen. What is recent and exceptional is the spread of the belief that it pays to make the accommodations furnished healthful, convenient, and attractive. The sources of profit from this careful provision are these: the proprietors have control of the territory, and are able to prescribe regulations which keep out the saloon and disreputable characters, and at once there is a saving in police and court and poor taxes; for the same reason the workmen are more regular and steady in their labor, for there is no St. Monday holiday, nor confused head and uncertain hand; the tenants are better able to pay their rents, and when their landlord and employer are the same person, he collects his rent out of the wages; the superior accommodations and more settled employment act strongly against labor strikes. It will be seen that the larger and better product of labor is a great factor in the profitableness of such enterprises, and that it arises from the improved character of the laborer, on the same principle that a farmer's stock pays him best when it is of good breed, is warmly housed, and well fed. Against the operations of the London Peabody and Waterlow funds it has been alleged that they dispossess the poor shiftless tenant and bring in a new class, so that they do not improve the condition of

their tenants, but afford opportunity for better ones to cheapen the price of their accommodations. The manufacturing landlord cannot wholly do this, because the first thing he has to consider is whether the applicant for a dwelling is a good workman, not whether he can be trusted for his rent. His labor he must have. His outlook is to make that labor worth more to him, by placing it in the best attainable surroundings. Can this be done? If so, the ends of humanity are answered as well as the purse filled, for both interests correspond.

Mr. Pullman, who founded the enterprise on Calumet Lake, has uttered sentiments like these, and has proved that in this instance it does pay to make his workmen's families comfortable, and secure from sickness and temptation. As a financial operation Pullman is profitable. There are now 1,700 dwellings, either separate or in apartment houses, in this town, where five years ago the prairie stretched on every side unbroken. Every tenement is connected with common sewerage, water, and gas systems, in which the most scientific principles and expert skill have been applied. The price of tenements ranges from \$5 per month for two rooms in an apartment house to \$16 for a separate dwelling of five rooms; but there is a different class of houses for clerks, superintendents, and overseers. The average price per room is \$3.30 a month, or nearly twelve per cent. higher than in Massachusetts manufacturing towns, where it is \$2.86. Taking each tenement at an average of three rooms, this rate will pay six per cent. on an investment of \$3,140,000, without taking into account taxes and repairs, or say six per cent. on \$3,000,000. But one source of profit of great moment must not be overlooked, and it is the appreciation of real estate by the increase of population. This is a small factor in a great city, at least so far as concerns the humbler grade of dwellings, but in the country it is enormous. A tract of land which has been a farm becomes a village of from 1,000 to 10,000 inhabitants. Its value advances by leaps and bounds.

At Pullman, in addition to the shops and dwellings, there are trees and turf-bordered malls and squares, a church, a theater, a free library with reading rooms, a public hall, a market house, provided at the expense of the company. Liquor can only be sold at the hotel to its guests, and then under restrictions. There is a system of public schools under a board of education, which is about the only civic organization, strictly speaking, in the community. One man suffices for police duty, and he made but fifteen arrests in the last two years. It is reported that the death rate so far, including the mortality from accidents, has been under seven in 1,000 per annum. In Great Britain the rate is a small fraction over 22 in 1,000. The vital statistics of the United States show a smaller mortality than this, but they are rendered abnormal by the heavy immigration which pours into the country. Emigrants are, in the language of insurance men, a selected class. They are usually at the most vigorous time of life and of hardiest and most enterprising spirit.

They leave behind them the very young and the old and those enfeebled by disease or habits. To this cause must be attributed in part the exceptional record of Pullman in death rate, as it is a new town. Yet there can be no question that the sanitary conditions of the place are excellent. It is difficult in mixed enterprises of this nature to tell what the rate of profit upon the tenement part of the business is, since the rental and the factory react upon each other; but in the American instances quoted in this article the investment as a whole is remunerative. In the Godin operations at Guise, which have been co-operative for the last five years, the capital is put at \$1,320,000, and the net earnings have averaged during that time \$204,640 per annum, or 15½ per cent.

At Pullman a demand has arisen on the part of the tenants for a chance to acquire proprietorship in their homes; and while the company has withheld the privilege from its original purchase of 3,500 acres, it has bought adjoining land, where it offers to advance money for building, and to take pay in monthly installments. This assimilates so much of the enterprise to that at Mulhausen, and shows the drift toward a co-operative phase of capital and labor. Indeed, this tendency will probably prove to be strongly characteristic of all similar schemes as fast as they attain to any magnitude. Tendencies which can be resisted in communities of few hundreds become overpowering when the population rises into thousands. But from the purely commercial point of view, this drift is hardly to be deprecated, so long as the operation of selling houses returns the capital and interest safely.

Projects of this nature go far toward modifying the stress of antagonisms between labor and capital, because if they are successful these are harmonized to an appreciable extent, and this gives public interest to them. The eventual adjustment must come, not from convictions of duty, doctrinaire opinions, or sentiments of sympathy, but on business principles, and it is a sure step in advance to show that self-interest and philanthropy are in accord. How great the field for experiments of this nature is in the United States may be gathered from the census of 1880, which shows 2,718,805 persons employed in the industrial establishments of the country, with an annual production of \$5,842,000,000, and a capital of nearly half that amount. Of these hands and values nearly two-thirds belong to the north Atlantic

HOTEL DE VILLE, ST. QUENTIN.

This charming building has an uncommonly well-designed facade, picturesque in the extreme, rich in detail, and thoroughly dignified. We are indebted to M. Levy, of Paris, for the loan of M. Garen's spirited etching, from which our illustration is taken. The arcaded piazza on the ground story, the niche-spaced tier of traceried windows on the first floor, the flamboyant paneled cornice stage, and the three crowning gables over it unite in one harmonious conception, the whole elevation being finished by a central tower, while at either end of the facade two massively treated buttresses furnish a satisfactory inclosing line, and give more than a suggestion of massiveness, so necessary to render an arcaded front like this quite complete within itself; otherwise it must more or less appear to be only part of a larger building. The style is Late Gothic, designed when the first influence of the Early Renaissance was beginning to be felt through France as well as Belgium, and in several respects the design has a Flemish character about it.



HOTEL DE VILLE, ST. QUENTIN.

St. Quentin is situated on the Goy, in the department of Cotes du Nord, and the town is seated in a picturesque valley some ten miles S.S.W. of the capital, St Brieuc, which is a bishop's see, and has a small harbor near the English Channel, and about thirty miles from St. Malo.—*Building News*.

FIRE DOORS IN MILLS.¹

There are few parts in fire construction which are of so much importance, and generally so little understood, as fire doors. Instances of the faulty construction of these, even by good builders and architects, may daily be seen. Iron doors over wooden sills, with the flooring boards extending through from one building to the other, are common occurrences. We frequently find otherwise good doors hung on wooden jambs by ordinary screws. Sliding doors are frequently hung on to woodwork, and all attachments are frequently so arranged that they would be in a very short time destroyed by fire, and cause the door to fall. In case of fire, a solid iron door offers no resistance to warping. In an iron lined door, on the contrary, the tendency of the sheet iron to warp is resisted by the interior wood, and when this burns into charcoal, it still resists all warping tendencies. I have seen heavily braced solid iron doors warped and turned after a fire, having proved themselves utterly worthless. It is needless to say that when wooden doors are lined, they should be lined on both sides; but frequently we find so-called fireproof doors lined on one side only.

Good doors are frequently blocked up with stock and other material, so that in case of fire they could not be closed without great exertion; or they have been allowed to get out of order, so that in case of fire they are useless. This has been so common that it has given rise to the jocular expression of insurance men, when they are told that a fire door exists between the two buildings, "Warranted to be open in case of fire." The strictest regulations should exist in regard to closing the fire doors nightly. Frequently we find that although the fire door, and its different parts, are correctly

made, there are openings in the wall which would allow the fire to travel from one building to the other, such as unprotected belt and shaft holes. That a fire door may be effective, it must be hung to the only opening in the wall.

The greatest care must be exercised to keep joists from extending too far into the wall, so as not to touch the joists of the adjacent building, which would transmit the flames from one building to the other in case of fire. A good stone sill should be placed under the door, and the floor thereby entirely cut. Sills should be raised about one and a half inches above the level of the floor, in order to accomplish the necessary flooring of the same. If stock must be wheeled from one building to the other, the sill can be readily beveled on both sides of the wall, allowing the wheels to pass readily over it. Lintels should consist of good brick arches. When swing doors are used, they should be hung on good iron staples, well walled into the masonry, and the staples so arranged that the door will have a tendency to close by its own weight. The door should consist of two layers of good one and a quarter inch boards, nailed crosswise, well nailed together and braced, and then covered with sheet iron nailed on, or if of sheet tin, flanged, soldered, and nailed. Particular care should be taken to insert plenty of nails, not only along the edge of the door, but crosswise in all directions. I have seen cases, where the entire covering had been ripped off through the warping tendencies of the sheet iron.

The hinges on these doors should be good strap hinges, tightly fastened to the door by bolts extending through it, and secured by nuts on the other side. Good latches which keep the door in position when closed should always be provided. In no case should the door be provided with a spring lock which cannot be freely opened, as employes might thereby be confined in a burning room.

Sliding doors should be hung on wrought iron runways, fastened tightly to the wall. Wooden runways iron lined, which we frequently see, are not good, as the charring of the wood in the interior causes them to weaken and the doors to drop. Runways should be on an incline, so that the door when not held open will close itself. Care must be taken to have a stop provided in the runway, so that the doors may not, as I have frequently seen them, overrun the opening which it is to protect. Doors should overlap the edges of the openings on all sides. Large projecting jambs should never be used.

All doors contained in "fire walls" should have springs or weights attached to them, so as to be at all times closed. Fire doors can be shut automatically by a weight, which is released by the melting of a piece of very fusible solder employed for this purpose. So sensitive is this solder that a fire door has been made to shut by holding a lamp some distance beneath the soldered link and holding an open handkerchief between the lamp and link. Though the handkerchief was not charred, hot air enough had reached the metal to fuse the solder and allow the apparatus to start into operation.

These solders are alloys more fusible than the most fusible of their component metals. A few of them are: Wood's alloy, consisting of: cadmium, 1 to 2 parts; tin, 2 parts; lead, 4 parts; bismuth, 7 to 8 parts.

This alloy is fusible between 150° and 159° Fahr. The fusible metal of D'Arcet is composed of: bismuth, 8 parts; lead, 5 parts; tin, 3 parts. It melts at 173.3°. We can, therefore, by proper mixture, form a solder which will melt at any desirable temperature. Numerous devices for closing doors automatically have been constructed, all depending upon the use of the fusible solder catch.

[1]

From a lecture before the Franklin Institute by C. John Hexamer.

STEEL STRUCTURES.

At a recent meeting of the Engineers' Club of Philadelphia, Mr. James Christie presented a paper upon "The Adaptation of Steel to Structural Work." The price of steel has now fallen so low, as compared with iron, that its increased use will be actively stimulated as the building industries revive. The grades and properties of the steels are so distinct and various that opinions differ much as to the adaptability of each grade for a special purpose. Hitherto, engineers have favored open hearth steel on account of uniformity, but recent results obtained from Bessemer steel tend to place either make on equality. The seeming tendency is to specify what the physical properties shall be, and not how the steel shall be made.

For boiler and ship plates, the mildest and most ductile steel is favored. For ships' frames and beams, a harder steel, up to 75,000 pounds tenacity, is frequently used. For tension members of bridges, steel of 65,000 to 75,000 pounds tenacity is usually

specified; and for compression members, 80,000 to 90,000 pounds. In the Forth Bridge, compression steel is limited to 75,000 to 82,000 pounds. Such a marked advantage occurs from the use of high tension steel in compression members, and the danger of sudden failure of a properly made strut is so little, that future practice will favor the use of hard steel in compression, unless the material should prove untrustworthy. In columns, even as long as forty diameters, steel of 90,000 pounds tenacity will exceed the mildest steel 35 per cent., or iron 50 per cent., in compressive resistance.

The present uncertainty consists largely as to how high-tension steel will endure the manipulation usual with iron without injury. A few experiments were recently made by the writer on riveted struts of both mild and hard steel, which had been punched, straightened, and riveted, as usual with iron, but no indication of deterioration was found.

Steel castings are now made entirely trustworthy for tensile working stresses of 10,000 to 15,000 pounds per square inch. In some portable machinery, an intermittent tensile stress is applied of 15,000 pounds, sometimes rising to 20,000 pounds per square inch of section, without any evidence of weakness.

Equal volumes of amyl alcohol (rectified fusel oil) and pure concentrated hydrochloric acid, shaken together in a test tube, unite to form a single colorless liquid; if one volume of benzine (from petroleum) be added to this, and the tube well shaken, the contents will soon separate into *three* distinct colorless fluids, the planes of demarkation being clearly discernible by transmitted light. Drop into the tube a particle of "acid magenta;" after again shaking the liquids together, the lower two zones will present different shades of red, while the supernatant hydrocarbon will remain without color.

A METHOD OF MEASURING THE ABSOLUTE SENSITIVENESS OF PHOTOGRAPHIC DRY PLATES.²

By WILLIAM H. PICKERING.

Within the last few years the subject of dry plate photography has increased very rapidly, not only in general popularity, but also in importance in regard to its applications to other departments of science. Numerous plate manufacturers have sprung up in this country as well as abroad, and each naturally claims all the good qualities for his own plates. It therefore seemed desirable that some tests should be made which would determine definitely the validity of these claims, and that they should be made in such a manner that other persons using instruments similarly constructed would be able to obtain the same results.

Perhaps the most important tests needed are in regard to the sensitiveness of the plates. Most plate makers use the wet plates as their standard, giving the sensitiveness of the dry plates at from two to sixty times greater; but as wet plates vary quite as much as dry ones, depending on the collodion, condition of the bath, etc., this system is very unsatisfactory. Another method, employed largely in England, depends on the use of the Warnerke sensitometer. In this instrument the light from a tablet coated with luminous paint just after being exposed to a magnesium light is permitted to shine through a colored transparent film of graduated density upon the plate to be tested. Each degree on the film has a number, and, after a given exposure, the last number photographed on the plate represents the sensitiveness on an empirical scale. There are two or three objections to this instrument. In the first place, the light-giving power of the luminous tablet is liable to variations, and, if left in a warm, moist place, it rapidly deteriorates. Again, it has been shown by Captain Abney that plates sensitized by iodides, bromides, and chlorides, which may be equally sensitive to white light, are not equally affected by the light emitted by the paint; the bromides being the most rapidly darkened, the chlorides next, and the iodides least of all. The instrument is therefore applicable only to testing plates sensitized with the same salts.

In this investigation it was first shown that the plates most sensitive for one colored light were not necessarily the most so for light of another color. Therefore it was evident that the sun must be used as the ultimate source of light, and it was concluded to employ the light reflected from the sky near the zenith as the direct source. But as this would vary in brilliancy from day to day, it was necessary to use some method which would avoid the employment of an absolute standard of light. It is evident that we may escape the use of this troublesome standard, if we can obtain some material which has a perfectly uniform sensitiveness; for we may then state the

sensitiveness of our plates in terms of this substance, regardless of the brilliancy of our source. The first material tried was white filter paper, salted and sensitized in a standard solution of silver nitrate. This was afterward replaced by powdered silver chloride, chemically pure, which was found to be much more sensitive than that made from the commercial chemicals. This powder is spread out in a thin layer, in a long paper cell, on a strip of glass. The cell measures one centimeter broad by ten in length. Over this is laid a sheet of tissue paper, and above that a narrow strip of black paper, so arranged so as to cover the chloride for its full length and half its breadth. These two pieces of paper are pasted on to the under side of a narrow strip of glass which is placed on top of the paper cell. The apparatus in which the exposures are made consists of a box a little over a meter in length, closed at the top by a board, in which is a circular aperture 15/8 cm. in diameter. Over this board may be placed a cover, in the center of which is a hole 0.05 cm. in diameter, which therefore lets through 0.00001 as much light as the full aperture. The silver chloride is placed a distance of just one meter from the larger aperture, and over it is placed the photographic scale, which might be made of tinted gelatines, or, as in the present case, constructed of long strips of tissue paper, of varying widths, and arranged like a flight of steps; so that the light passing through one side of the scale traverses nine strips of paper, while that through the other side traverses only one strip. Each strip cuts off about one-sixth of the light passing through it, so that, taking the middle strip as unity, the strips on either side taken in order will transmit approximately—

1	2	3	4	5	6	7	8	9
2.0	1.65	1.4	1.2	1.0	0.85	0.7	0.6	0.5

The instrument is now pointed toward the zenith for about eight minutes, on a day when there is a bright blue sky. On taking the apparatus into the dark room and viewing the impression by gaslight, it will be found that the markings, which are quite clear at one end, have entirely faded out by the time the middle division is reached. The last division clearly marked is noted. Five strips cut from sensitized glass plates, ten centimeters long and two and a half in width, are now placed side by side under the scale, in the place of the chloride. By this means we can test, if we wish, five different kinds of plates at once. The cover of the sensitometer containing the 0.05cm. hole is put on, and the plates exposed to sky light for a time varying anywhere between twenty seconds and three minutes, depending on the sensitiveness of the plates. The instrument is then removed to the dark room, and the plates developed by immersing them all at once in a solution consisting of four parts potassium oxalate and one part ferrous sulphate. After ten minutes they are removed, fixed, and dried. Their readings are then noted, and compared with those obtained with the silver chloride. The chloride experiment is again performed as soon as the plates have been removed, and the first result confirmed. With some plates it is necessary to make two or three trials before the right exposure can be found; but if the image disappears anywhere between the second and eighth divisions, a satisfactory result may be obtained.

The plates were also tested using gaslight instead of daylight. In this case an Argand burner was employed burning five cubic feet of gas per hour. A diaphragm 1 cm. in diameter was placed close to the glass chimney, and the chloride was placed at 10 cm. distance, and exposed to the light coming from the brightest part of the flame, for ten hours. This produced an impression as far as the third division of the scale. The plates were exposed in the sensitometer as usual, except that it was found convenient in several cases to use a larger stop, measuring 0.316 cm. in diameter.

The following table gives the absolute sensitiveness of several of the best known kinds of American and foreign plates, when developed with oxalate, in terms of pure silver chloride taken as a standard. As the numbers would be very large, however, if the chloride were taken as a unit, it was thought better to give them in even hundred thousands.

SENSITIVENESS OF PLATES.

Plates.	Daylight.	Gaslight.
Carbutt transparency	0.7	..
Allen and Rowell	1.3	150
Richardson standard	1.3	10
Marshall and Blair	2.7	140
Blair instantaneous	3.0	140
Carbutt special	4.0	20
Monroe	4.0	25
Wratten and Wainwright	4.0	10
Eastman special	5.3	30
Richardson instantaneous	5.3	20
Walker Reid and Inglis	11.0	600
Edwards	11.0	20
Monckhoven	16.0	120
Beebe	16.0	20
Cramer	16.0	120

It will be noted that the plates most sensitive to gaslight are by no means necessarily the most sensitive to daylight; in several instances, in fact, the reverse seems to be true.

It should be said that the above figures cannot be considered final until each plate has been tested separately with its own developer, as this would undoubtedly have some influence on the final result.

Meanwhile, two or three interesting investigations naturally suggest themselves; to determine, for instance, the relative actinism of blue sky, haze, and clouds; also, the relative exposures proper to give at different hours of the day, at different seasons of the year, and in different countries. A somewhat prolonged research would indicate what effect the presence of sunspots had on solar radiation—whether it was increased or diminished.

[2]

From the Proceedings of the Academy of Arts and Sciences.—*Amer. Jour.*

NATURAL GAS FUEL AND ITS APPLICATION TO MANUFACTURING PURPOSES.³

By Mr. ANDREW CARNEGIE, New York.

In these days of depression in manufacturing, the world over, it is specially cheering to be able to dwell upon something of a pleasant character. Listen, therefore, while I tell you about the natural gas fuel which we have recently discovered in the Pittsburg district. That Pittsburg should have been still further favored in the matter of fuel seems rather unfair, for she has long been noted for the cheapest fuel in the world. The actual cost of coal, to such as mine their own, has been between 4s. and 5s. per ton; while slack, which has always been very largely used for making gas in Siemens furnaces and under boilers, has ranged from 2s. to 2s. 6d. per ton. Some mills situated near the mines or upon the rivers for many years received slack coal at a cost not exceeding 1s. 6d. per ton. It is this cheap fuel which natural gas has come to supplant. It is now many years since the pumping engines at oil wells were first run by gas, obtained in small quantities from many of the holes which failed to yield oil. In several cases immense gas wells were found near the oil district; but some years elapsed before there occurred to any one the idea of piping it to the nearest manufacturing establishments, which were those about Pittsburg. Several years ago the product of several gas wells in the Butler region was piped to two mills at Sharpsburg, five miles from the city of Pittsburg, and there used as fuel, but not with such triumphant success as to attract much attention to the experiment. Failures of supply, faults in the tubing, and imperfect appliances for use at the mills combined to make the new fuel troublesome. Seven years ago a company drilled for oil at Murraysville, about eighteen miles from Pittsburg. A depth of 1,320 feet had been reached when the drills were thrown high in the air, and the derrick broken to pieces and scattered around by a tremendous explosion of gas. The roar of escaping gas was heard in Munroville, five miles distant. After four pipes, each two inches in diameter, had been laid from the mouth of the well and the flow directed through them, the gas was ignited, and the whole district for miles round was lighted up. This valuable fuel, although within nine miles of our steel-rail mills at Pittsburg, was permitted to waste for five years. It may well be asked why we did not at once secure the property and utilize this fuel; but the business of conducting it to the mills and there using it was not well understood until recently. Besides this, the cost of a line was then more than double what it is now; we then estimated that £140,000 would be required to introduce the new fuel. The cost to-day does not exceed £1,500 per mile. As our coal was not costing us more than 3s. per ton of finished rails, the inducement was not in our opinion great enough to justify the expenditure of so much capital and taking the risk of failure of the supply. Two years ago men who had more knowledge of the oil-wells than ourselves had sufficient faith in the continuity of the gas supply to offer to furnish us with gas for a sum per year equal to that hitherto annually paid for coal until the amount expended by them on piping had been repaid, and afterward at half that sum. It took us about eighteen months to recoup the gas company, and we are now working under the permanent arrangement of one-half the previous cost of fuel on cars at work. Since our success in the use of this new natural fuel at the rail mills, parties still bolder have invested in lines of piping to the city of Pittsburg, fifteen to eighteen miles from the wells. The territory underlain with this natural gas has not yet been clearly defined. At the principal field, that of Murraysville (from which most of the gas is obtained to-day), I found, upon my visit to that interesting region last autumn, that nine wells had been sunk, and were yielding gas in large quantities. One of these was estimated as yielding 30,000,000 cubic feet in 24 hours. This district lies to the northeast of Pittsburg, running southward from it toward the Pennsylvania Railroad. Gas has been found upon a belt averaging about half a mile in

width for a distance of between four and five miles. Beyond that again we reach a point where salt water flows into the wells and drowns the gas. Several wells have been bored upon this belt near the Pennsylvania Railroad, and have been found useless from this cause. Geologists tell us that in this region a depression of 600 feet occurs in the strata, but how far the fault extends has not yet been ascertained. Wells will no doubt soon be sunk southward of the Pennsylvania Railroad upon this half-mile belt. Swinging round toward the southwest, and about twenty miles from the city, we reach the gas fields of Washington county. The wells so far struck do not appear to be as strong as those of the Murrysville district, but it is possible that wells equally productive may be found there hereafter. There are now four wells yielding gas in the district, and others are being drilled. Passing still further to the west, we reach another gas territory, from which manufacturing works in Beaver Falls and Rochester, some twenty-eight miles west of Pittsburg, receive their supply. Proceeding with the circle we are drawing in imagination around Pittsburg, we pass from the west to the southwest without finding gas in any considerable quantity, until we reach the Butler gas field, equidistant from Pittsburg on the northwest, with Washington county wells on the southwest. Proceeding now from the Butler field to the Allegheny River, we reach the Tarentum district, still about twenty miles from Pittsburg, which is supplying a considerable portion of the gas used. Drawing thus a circle around Pittsburg, with a radius of fifteen to twenty miles, we find four distinct gas-producing districts. In the city of Pittsburg itself several wells have been bored; but the fault before mentioned seems to extend toward the center of the circle, as salt water has rushed in and rendered these wells wholly unproductive, though gas was found in all of them.

I spent a few days very pleasantly last autumn driving with some friends to the two principal fields, the Murrysville and the Washington county. In the former district the gas rushes with such velocity through a 6-inch pipe, extending perhaps 20 feet above the surface, that it does not ignite within 6 feet of the mouth of the pipe. Looking up into the clear blue sky, you see before you a dancing golden fiend, without visible connection with the earth, swayed by the wind into fantastic shapes, and whirling in every direction. As the gas from the well strikes the center of the flame and passes partly through it, the lower part of the mass curls inward, giving rise to the most beautiful effects gathered into graceful folds at the bottom—a veritable pillar of fire. There is not a particle of smoke from it. The gas from the wells at Washington was allowed to escape through pipes which lay upon the ground. Looking down from the roadside upon the first well we saw in the valley, there appeared to be an immense circus-ring, the verdure having been burnt and the earth baked by the flame. The ring was quite round, as the wind had driven the flame in one direction after another, and the effect of the great golden flame lying prone upon the earth, swaying and swirling with the wind in every direction, was most startling. The great beast Apollyon, minus the smoke, seemed to have come forth from his lair again. The cost of piping is now estimated, at the present extremely low prices, with right of way, at £1,600 sterling per mile, so that the cost of a line to Pittsburg may be said to be about £27,000 sterling. The cost of drilling is about £1,000, and the mode of procedure is as follows: A derrick being first erected, a 6 inch wrought-iron pipe is driven down through the soft earth till rock is reached from 75 to 100 feet. Large drills, weighing from 3,000 to 4,000 lb., are now brought into use; these rise and fall with a stroke of 4 to 5 feet. The fuel to run these drills is conveyed by small pipes from adjoining wells. An 8-inch hole having been bored to a depth of about 500 feet, a 5-5/8 inch wrought-iron pipe is put down to shut off the water. The hole is then continued 6 inches in diameter until gas is struck, when a 4-inch pipe is put down. From forty to sixty days are consumed in sinking the well and striking gas. The largest well known is estimated to yield about 30,000,000 cubic feet of gas in twenty-four hours, but half of this may be considered as the product of a good well. The pressure of gas as it issues from the mouth of the well is nearly or quite 200 lb. per square inch. One of the gauges which I examined showed a pressure of 187 lb. Even at works where we use the gas nine miles from the well, the pressure is 75 lb. per square inch. At one of the wells, where it was desirable to have a supply of pure water, I found a small engine worked by the direct pressure of the gas as it came from the well; and an excellent supply of water was thus obtained from a spring in the valley. Eleven lines of pipe now convey gas from the various wells to the manufacturing establishments in and around Pittsburg. The largest of these for the latter part of the distance is 12 inches in diameter. Several are of 8 inches throughout. The lines originally laid are 6 inches in diameter. Many of the mills have as yet no appliances for using the gas, and much of it is still wasted. It is estimated that the iron and steel mills of the city proper require fuel equal to 166,000 bushels of coal per day; and though it is only two years since gas was first used in Pittsburg, it has already displaced about 40,000 bushels of coal per day in these mills. Sixty odd glass works, which required about 20,000 bushels of coal per day, mostly now use the natural gas. In the work around Pittsburg beyond the city limits, the amount of coal superseded by gas is about equal to that displaced in the city. The estimated number of men whose labor will be dispensed with in Pittsburg when gas is generally used is 5,000. It is only a question of a few months when all the manufacturing carried on in the district will be operated with the new fuel. As will be seen from the

analyses appended to this paper, it is a much purer fuel than coal; and this is a quality which has proved of great advantage in the manufacture of steel, glass, and several other products. With the exception of one, and perhaps two concerns, no effort has been made to economize in the use of the new fuel. In our Union Iron Mills we have attached to each puddling furnace a small regenerative appliance, by the aid of which we save a large percentage of fuel. The gas companies will no doubt soon require manufacturers to adopt some such appliance. At present, owing to the fact that there is a large surplus constantly going to waste, they allow the gas to be used to any extent desired. Contracts are now made to supply houses with gas for all purposes at a cost equal to that of the coal bill for the preceding year. In the residences of several of our partners no fuel other than this gas is now used, and everybody who has applied it to domestic purposes is delighted with the change from the smoky and dirty bituminous coal. Some, indeed, go so far as to say that if the gas were three times as costly as the old fuel, they could not be induced to go back to the latter. It is therefore quite within the region of probability that the city, now so black that even Sheffield must be considered clean in comparison, may be so revolutionized as to be the cleanest manufacturing center in the world. A walk through our rolling mills would surprise the members of the Institute. In the steel rail mills for instance, where before would have been seen thirty stokers stripped to the waist, firing boilers which require a supply of about 400 tons of coal in twenty-four hours—ninety firemen in all being employed, each working eight hours—they would now find one man walking around the boiler house, simply watching the water gauges, etc. Not a particle of smoke would be seen. In the iron mills the puddlers have whitewashed the coal bunkers belonging to their furnaces. I need not here say how much pleasure it will afford me to arrange that any fellow members of the Institute who may visit the republic are afforded an opportunity to see for themselves this latest and most interesting development of the fuel question. Good Mother Earth supplies us with all the fuel we can use and more, and only asks us to lead it under our boilers and into our heating and puddling furnaces, and apply the match. During the winter several explosions have occurred in Pittsburg, owing to the escape of gas from pipes improperly laid. The frost having penetrated the earth for several feet and prevented escape upward, the freed gas found its way into the cellars of houses, and, as it is odorless, its presence was not detected. This resulted in several alarming explosions; but the danger is to be remedied before next year. Lower pressure will be carried in the pipes through the city, and escape pipes leading to the surface will be placed along the surface at frequent intervals. In the case of manufacturing establishments, the gas is led into the mills overhead, and, all the pipes being in the open air, no danger of explosion is incurred.

The following extract from the report of a committee, made to the American Society of Mechanical Engineers at a recent meeting, gives an idea of the value of the new fuel: "Natural gas, next to hydrogen, is the most powerful of the gaseous fuels, and, if properly applied, one of the most economical, as very nearly its theoretical heating power can be utilized in evaporating water. Being so free from all deleterious elements, notably sulphur, it makes better iron, steel, and glass than coal fuel. It makes steam more regularly, as there is no opening of doors, and no blank spaces are left on the grate bars to let cold air in, and, when properly arranged, regulates the steam pressure, leaving the man in charge nothing to do but to look after the water, and even that could be accomplished if one cared to trust to such a volatile water-tender. Boilers will last longer, and there will be fewer explosions from unequal expansion and contraction, due from cold draughts of air being let in on hot plates.

"An experiment was made to ascertain the value of gas as a fuel in comparison with coal in generating steam, using a retort or boiler of 42 inches diameter, 10 feet long, with 4 inch tubes. It was first fired with selected Youghiogheny coal, broken to about 4 inch cubes, and the furnace was charged in a manner to obtain the best results possible with the stack that was attached to the boiler. Nine pounds of water evaporated to the pound of coal consumed was the best result obtained. The water was measured by two meters, one in the suction and the other in the discharge. The water was fed into a heater at a temperature of from 60° to 62°; the heater was placed in the flue leading from the boiler to the stack in both gas and coal experiments. In making the calculations, the standard 76 lb. bushel of the Pittsburg district was used. Six hundred and eighty-four pounds of water were evaporated per bushel, which was 60.9 per cent. of the theoretical value of the coal. Where gas was burned under the same boiler, but with a different furnace, and taking 1 lb. of gas to be 2.35 cubic feet, the water evaporated was found to be 20.31 lb., or 83.4 per cent. of the theoretical heat units were utilized. The steam was under the atmospheric pressure, there being a large enough opening to prevent any back pressure, the combustion of both gas and coal was not hurried. It was found that the lower row of tubes could be plugged and the same amount of water could be evaporated with the coal; but with gas, by closing all the tubes—on the end next the stack—except enough to get rid of the products of combustion, when the pressure on the walls of the furnace was three ounces, and the fire forced to its best, it was found that very nearly the same results could be obtained. Hence it was concluded that the most of

the work was done on the shell of the boiler."

In no other way can I give the members of the Iron and Steel Institute so much information in regard to this new fuel as by including in this paper a very able communication from the chief chemist at our Edgar Thomson Steel Works, Mr. S.A. Ford, who is to-day the highest authority upon the subject:

"So much has been claimed for natural gas as regards the superiority of its heating properties as compared with coal, that some analyses of this gas, together with calculations showing the comparison between its heating power and that of coal, may be of interest. These calculations are, of course, theoretical in both cases, and it must not be imagined that the total amount of heat, either in a ton of coal or 1,000 cubic feet of natural gas, can ever be fully utilized. In making these calculations I employed as a basis what in my estimation was a gas of an average chemical composition, as I have found that gas from the same well varies continually in its composition. Thus, samples of gas from the same well, but taken on different days, vary in nitrogen from 23 per cent. to *nil*, carbonic acid from 2 per cent. to *nil*, oxygen from 4 per cent. to 0.4 per cent., and so with all the component gases. Before giving the theoretical heating power of 1,000 cubic feet of this gas I will note a few analyses. The first four are of gas from the same well; samples taken on the same day that they were analyzed. The two last are from two different wells in the East Liberty district:

ANALYSES OF NATURAL GAS.

	1	2	3	4	5	6
When tested.....	10-28-84	10-29-84	11-24-84	12-4-84	10-18-84	10-25-84
	per ct.	per ct.	per ct.	per ct.	per ct.	per ct.
Carbonic acid	0.8	0.6	Nil.	0.4	Nil.	0.30
Carbonic oxide.....	1.0	0.8	.58	0.4	1.0	0.30
Oxygen... ..	1.1	0.8	.78	0.8	2.10	1.20
Olefiant gas	0.7	0.8	0.98	0.6	0.80	0.6
Ethylic hydride	3.6	5.5	7.92	12.30	5.20	4.8
Marsh gas	72.18	65.25	60.70	49.58	57.85	75.16
Hydrogen	20.02	26.16	29.03	35.92	9.64	14.45
Nitrogen	Nil.	Nil.	Nil.	Nil.	23.41	2.89
Heat units	728,746	698,852	627,170	745,813	592,380	745,591

"We will now show how the natural gas compares with coal, weight for weight, or, in other words, how many cubic feet of natural gas contain as many heat units as a given weight of coal, say a ton. In order to accomplish this end we will be obliged, as I have said before, to assume as a basis for our calculations what I consider a gas of an average chemical composition, viz.:

	Per cent.
Carbonic acid.....	0.60
Carbonic oxide.....	0.60
Oxygen.....	0.80
Olefiant gas.....	1.00
Ethylic hydride.....	5.00
Marsh gas.....	67.00
Hydrogen.....	22.00
Nitrogen.....	3.00

"Now, by the specific gravity of these gases we find that 100 liters of this gas will weigh 64.8585 grammes, thus:

	Liters.	Weight, grammes.
Marsh gas.....	67.0	48.0256
Olefiant gas.....	1.0	1.2534
Ethylic hydride.....	5.0	6.7200
Hydrogen.....	22.0	1.9712
Nitrogen.....	3.0	3.7632
Carbonic acid.....	0.6	1.2257
Carbonic oxide.....	0.6	0.7526
Oxygen.....	0.8	1.1468
Total.....		64.8585

"Then, if we take the heat units of these gases, we will find:

	Grammes.	Heat units contained.
Marsh gas.....	48.0256	627,358
Olefiant gas.....	1.2534	14,910
Ethylic hydride.....	6.7200	77,679
Hydrogen.....	1.9712	67,929

Carbonic oxide.....	0.7526	1,808
Nitrogen.....	3.7630	-----
Carbonic acid.....	1.2257	-----
Oxygen.....	1.1468	-----
	-----	-----
Totals	64.8585	789,694

"64.8585 grammes are almost exactly 1,000 grains, and 1 cubic foot of this gas will weigh 267.9 grains; then the 100 liters, or 64.8585 grammes, or 1,000 grains, are 3,761 cubic feet; 3,761 cubic feet of this gas contains 789,694 heat units, and 1,000 cubic feet will contain 210,069,604 heat units. Now, 1,000 cubic feet of this gas will weigh 265,887 grains, or in round numbers 38 lb. avoirdupois. We find that 64.8585 grammes, or 1,000 grains, of carbon contain 523,046 heat units, and 265,887 grains, or 38 lb., of carbon contain 139,398,896 heat units. Then 57.25 lb. of carbon contain the same number of heat units as 1,000 cubic feet of the natural gas, viz., 210,069,604. Now, if we say that coke contains in round numbers 90 per cent. carbon, then we will have 62.97 lb. of coke, equal in heat units to 1,000 cubic feet of natural gas. Then, if a ton of coke, or 2,000 lb., cost 10s., 62.97 lb. will cost 4d., or 1,000 cubic feet of gas is worth 4d. for its heating power. We will now compare the heating power of this gas with bituminous coal, taking as a basis a coal slightly above the general average of the Pittsburg coal, viz.:

	Per cent.
Carbon.....	82.75
Hydrogen.....	5.31
Nitrogen.....	1.04
Oxygen.....	4.64
Ash.....	5.31
Sulphur.....	0.95

"We find that 38 lb. of this coal contains 146,903,820 heat units. The 64.4 lb. of this coal contains 210,069,640 heat units, or 54.4 lb. of coal is equal in its heating power to 1,000 cubic feet of natural gas. If our coal cost us 5s. per ton of 2,000 lb., then 54.4 lb. costs 1.632d., and 1,000 cubic feet of gas is worth for its heat units 1.632d. As the price of coal increases or decreases, the value of the gas will naturally vary in like proportions. Thus, with the price of coal at 10s. per ton the gas will be worth 3.264d. per 1,000 cubic feet. If 54.4 lb. of coal is equal to 1,000 cubic feet of gas, then one ton, or 2,000 lb., is equal to 36,764 cubic feet, or 2,240 lb. of coal is equal to 40,768 cubic feet of natural gas. If we compare this gas with anthracite coal, we find that 1,000 cubic feet of gas is equal to 58.4 lb. of this coal, and 2,000 lb. of coal is equal to 34,246 cubic feet of natural gas. Then, if this coal cost 26s. per ton, 1,000 cubic feet of natural gas is worth 9½d. for its heating power. In collecting samples of this gas I have noticed some very interesting deposits from the wells. Thus, in one well the pipe was nearly filled up with a soft grayish-white material, which proved on testing to be chloride of calcium. In another well, soon after the gas vein had been struck, crystals of carbonate of ammonia were thrown out, and upon testing the gas I found a considerable amount of that alkali, and with this well no chloride of calcium was observed until about two months after the gas had been struck. In these calculations of the heating power of gas and coal no account is of course taken of the loss of heat by radiation, etc. My object has been to compare these two fuels merely as regards their actual value in heat units."

Bearing in mind that it is never wise to prophesy unless you know, I hesitate to speak of the future; but considering the experience we have had in regard to the productiveness of the oil territory, which is now yielding 70,000 barrels of petroleum per day, and which has continued to increase year after year for twenty years, I see no reason to doubt the opinion of experts that the territory which has already been proved to yield gas will suffice for at least the present generation in and about Pittsburg.

[3]

Read before the Iron and Steel Institute of London, May 8, 1885.

A GAS-ENGINE WATER-SUPPLY ALARM.

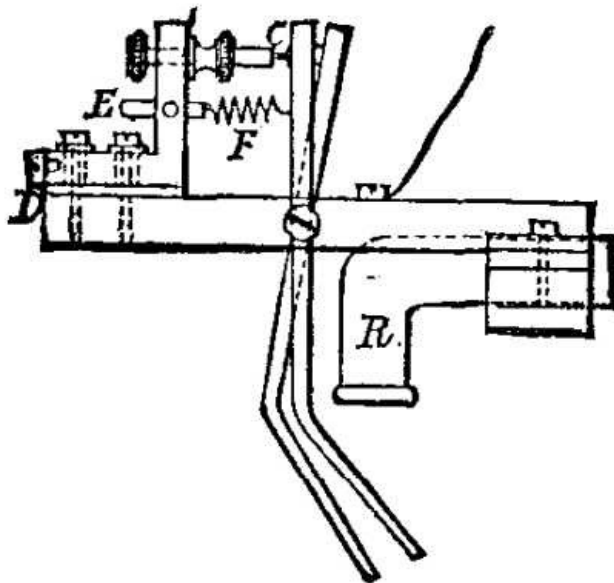

A very useful contrivance for the purpose of reporting automatically the failure of the water supply to a gas-engine has been arranged by Professor Ph. Carl, of Munich. What led to the adoption of the device was that, during last winter, the water supply in the neighborhood of the Professor's laboratory was several times cut off without previous notice; the result being the failure of the water needed for cooling the cylinder of his Otto gas-engine. On inquiring into the matter, he discovered that the same thing frequently occurred in other places where gas-engines were in use; and this caused him to design a contrivance to put an alarm-bell into action at the instant when the water ceased to flow, and so enable any overheating of the engine, and injuries thereby resulting, to be prevented in time. The arrangement (represented half size in the accompanying engraving) is screwed down directly to the water outflow pipe, R. Before the aperture of the pipe is a lever, with a disk on one arm, on to which the issuing water impinges, thereby keeping the lever in the position indicated by the dotted lines. The effect of this is to break the platinum contact at C, and so interrupt the circuit of an alarm-bell placed in any suitable position. Suppose the water ceases to flow; the spring, F, comes into play, contact is made at C, and the bell continues to ring till some one comes to stop it. It is almost needless to remark that the disk, D, and the pin, E, are composed of insulating material, such as vulcanite.—*Jour. Gas Lighting.*

SOLDERING AND REPAIRING PLATINUM VESSELS IN THE LABORATORY.

By J.W. PRATT, F.C.S.

It frequently happens in the laboratory that platinum vessels, after long-continued use, begin to show signs of wear, and become perforated with minute pinholes. When they have reached this stage, they are usually accounted of no further utility, and are disposed of as scrap; not that it is impossible to repair them—for with fine gold wire and an oxyhydrogen jet this is easily feasible—but that the proper appliances and skill are not in possession of all. Irrespective of the manipulation of the hydrogen jet, it is rather difficult without long practice to hold the end of the fine wire precisely over the aperture and to keep it in position. It occurred to me that, if the gold in a finely divided condition could be placed in very intimate contact with the platinum, judging from the fusibility of gold-platinum alloys, union could be effected at a lower temperature over the ordinary gas blowpipe. I tried the experiment, and found the supposition correct. The substance I used was auric chloride, AuCl_3 , which, as is well known, splits up on heating, first into aurous chloride, and at a higher temperature gives off all its chlorine and leaves metallic gold. Operating on a perforated platinum basin, in the first instance, I placed a few milligrammes of the aurous chloride from a 15 grain tube precisely over the perforation, and then gently heated to about 200°C . till the salt melted and ran through the holes. A little further heating caused the reduced gold to solidify on each side of the basin. The blowpipe was now brought to bear on the bottom of the dish, right over the particular spots it was wished to solder, and in a few moments, at a yellow-red heat (in daylight), the gold was seen to "run." On the vessel being immediately withdrawn, a very neat soldering was evident. The operation was repeated several times, till in a few minutes the dish had been rendered quite tight and serviceable.

Using the gold salt in this way, the principal difficulty experienced in holding gold

wire unflinchingly in the exact position vanishes, while only a comparatively low temperature and small amount of gold is necessary. Care must be taken to withdraw the platinum from the flame just at the moment the gold is seen to run, for if the heat be continued longer, the gold alloys with a larger surface of platinum, spreads, and leaves the aperture empty. As in the case of all gold-soldered vessels, the article cannot afterward be safely exposed to a temperature higher than that at which the soldering was effected, and on this account it is advisable to use as small an amount of auric chloride as possible. When the perforations are of comparatively large size, the repairing is not so easy, owing to the auric chloride, on fusing, refusing to fill them. I find, however, that if some spongy platinum be mixed with a few milligrammes of the gold salt, pressed into the perforation, and heat applied as directed, a very good soldering can be effected. It is well to hammer the surface of the platinum while hot, so as to secure perfect union and welding of the two surfaces. This may be done in a few minutes in such a manner as to render the repair indistinguishable. Strips of platinum may be joined together in much the same way as already described—a few crystals of auric chloride placed on each clean surface and gently heated till nearly black, then bound together and further heated for a few moments in the blowpipe flame. Rings and tubes can also be formed on a mandrel, and soldered in the same fashion, and the chemist thus enabled to build up small pieces of apparatus from sheet platinum in the laboratory.—*Chem. News.*

THE HELICOIDAL OR WIRE STONE SAW.

The sides of solid bodies, whatever be the degree of hardness, and however fine the texture, possess surfaces formed of a succession of projections and depressions. When two bodies are in contact, these projections and indentations fit into one another, and the adherence that results is proportional to the degree of roughness of the surfaces. If, by a more or less energetic mechanical action, we move one of the bodies with respect to the other, we shall produce, according as the action overcomes cohesion, more or less disintegration of the bodies. The resulting wear in each of them will evidently be inversely proportional to its hardness and the nature of its surface; and it will vary, besides, with the pressure exerted between the surfaces and the velocity of the mechanical action. We may say, then, that the wear resulting from rubbing two bodies against each other is a function of their degree of hardness, of the extent and state of their surface, of the pressure, of the velocity, and of the time.

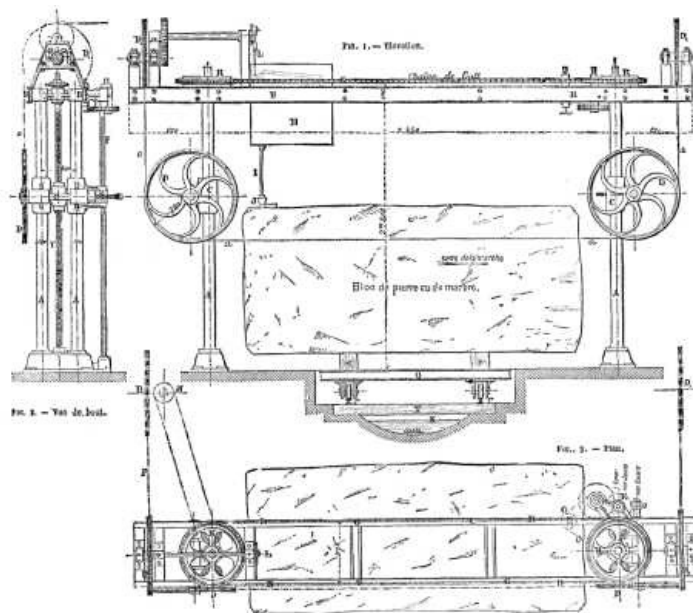

FIGS. 1, 2 and 3.—APPARATUS FOR SAWING STONE.

According as these factors are varied in a sense favorable or unfavorable to their proper action, we obtain variations in the final erosion. Thus, in rubbing together two bodies of different hardness and nature of surface, we obtain a wear inversely proportional to the hardness and state of polish of their surfaces. Through the interposition of a pulverized hard body we can still further accelerate such wear, as a consequence of the rapid renewal of the disintegrating element.

The gradual wear effected over the entire surface of a body brings about a polish, while that effected along a line or at some one point determines a cleavage or an aperture.

The process usually employed in quarries or stone-yards for sawing consists in slowly moving a stone-saw backward and forward, either by hand or machinery, and with

scarcely any pressure. Mr. P. Gray has, however, devised a new process, which is based upon the theoretical considerations given above. His *helicoidal* saw is, in reality, an endless cable formed by twisting together three steel wires in such a way as to give the spirals quite an elongated pitch.

The apparatus in its form for cutting blocks of stone into large slabs (Figs. 1, 2, and 3) consists of two frames, A A, five feet apart, each formed of two iron columns, $7\frac{1}{2}$ feet in height and one foot apart, fixed to cast iron bases resting upon masonry. At the upper part, a frame, B B, formed of double T-irons cross-braced here and there, supports a transmission composed of gearwheels, R R, and a pitch-chain, G G. Along the columns of the frame, which serve as guides, move two kinds of pulley-carriers, C C. The pulleys, D D, are channeled, and receive the cable, a a, which serves as a helicoidal saw. The direction of the saw's motion is indicated by the arrow. The carriages, C C, are traversed by screws, V V, which are fixed between the columns. The extremity, v, of the axle of the pulley to the right is threaded, and actuates a helicoidal wheel, E, which transmits motion to the wheel, R, through the intermedium of the vertical shaft, F. This transmission, completed by the wheels, R R, and the pitch-chains, G G, is designed to move the saw vertically, through the simultaneous shifting of the carriages, C C. A tension weight, P, through the intermedium of pulleys, D₁ D₁, permits of keeping the saw taut. A reservoir, H, at the upper part of the frame, B B, contains the water and sand necessary for sawing. The feeding is effected by means of a rubber tube, I, terminating in a flattened rose, J, which is situated over the aperture made by the saw. A small pump, L, over the reservoir takes water from K, and raises it to H. The sand is put in by hand.

Above the basin, K, a system of rails and ties supports the carriage, Q, upon which is placed the block of stone to be sawn. When one operation has been finished, and it is desired to begin another, it is necessary to raise the pulley-carriers and the saw. In order to do this quickly, there is provided a special transmission, M, which is actuated by hand, through a winch.

The work done by this saw is effected more rapidly than by the ordinary processes, and certain very hard rocks, usually regarded as almost intractable, can be sawed at the rate of from one to one and a half inches per hour.

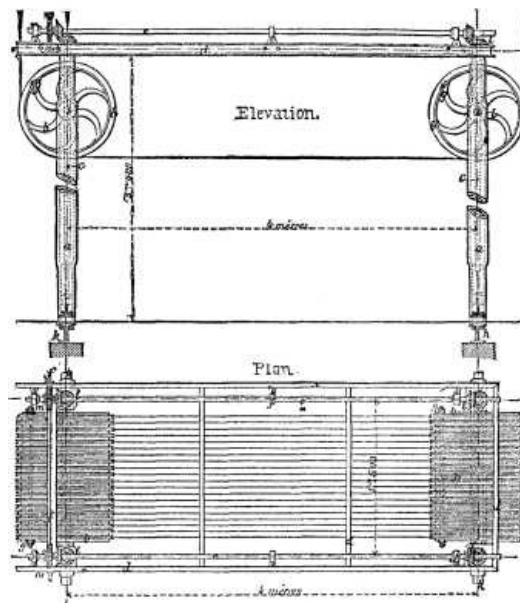

FIG. 4.—APPARATUS FOR SAWING STONE INTO SLABS.

For sawing marble into slabs of all thicknesses, the arrangement described above may be replaced by a system consisting of two drums having several channels to receive as many saws, or two corresponding series of channeled pulleys, b b (Fig. 4), independent of each other, but keyed to the same axles, i i. When the pulleys have been properly spaced by means of keys, the whole affair is rendered solid by a bolt, g. The extremity of the axles forms a nut into which pass vertical screws, c c. These latter are connected above with cone-wheels, l l, which, gearing with bevel wheels keyed to the shafts, e, secure a complete interdependence of the whole. The ascending motion, which is controlled by the endless screws, f, and the helicoidal wheels, m, is in this way effected with great regularity. Uprights, a a, of double T-iron, fixed to joists, k k, and connected and braced by pieces, d d, form a strong frame.

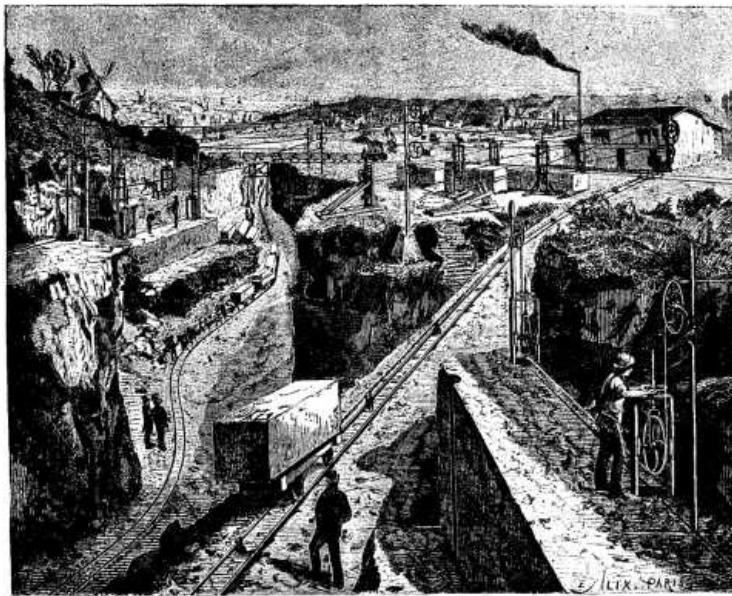

FIG. 5.—APPLICATION OF GAY'S STONE SAW IN A MARBLE QUARRY.

The power necessary to run this kind of saw is less than $n \times \frac{1}{4}$ H.P., on account of the number of passive parts. The most interesting application of the helicoidal saw is in the exploitation of quarries. Fig. 5 represents a Belgian marble quarry which is being worked by Mr. Gay's method.

Tubular Perforators.—Mr. Gay has rendered his saw completer by the invention of a tubular perforator for drilling the preliminary well. It is based upon the same principle as the Leschot rotary drill, but differs from that in its extremity being simply of tempered steel instead of being set with black diamonds. A special product, called metallic agglomerate, is used instead of sand for hastening the work.

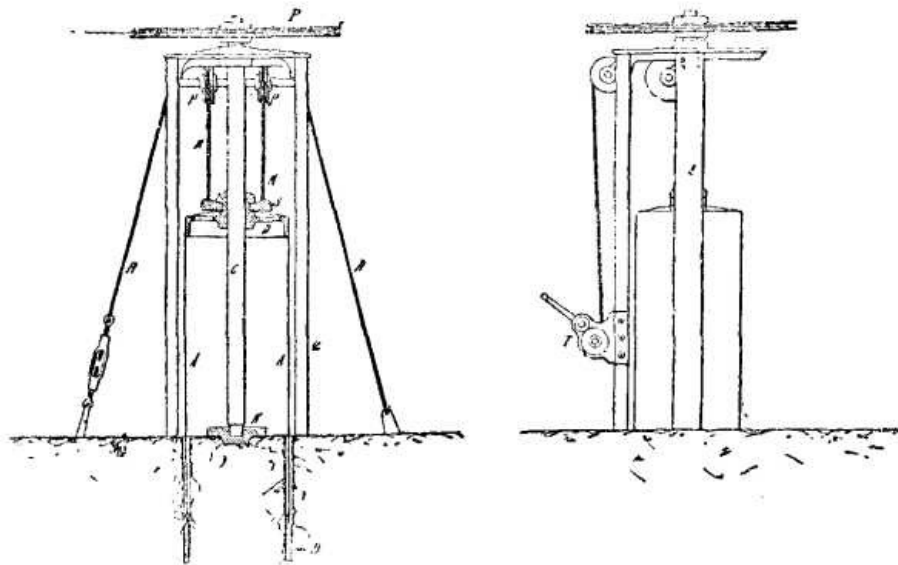

FIG. 6.—TUBULAR PERFORATOR.

The apparatus, Fig. 6, consists of an iron plate cylinder, A, 27½ inches in diameter, and of variable length, according to the depth to be obtained, and terminating beneath in a steel head, B, of greater thickness. This cylinder is traversed by a shaft, C, to which it is keyed, and which passes through the center of the aperture drilled. This shaft is connected with the cylinder, A, through the intermedium of cross bars, D, and transmits thereto a rapid rotary motion, which is received at the upper part from a telodynamic wire that passes through the channel of the horizontal pulley, P. This latter is supported by a frame consisting of three uprights, Q Q, strengthened by stays, R R, fixed to the ground.

In order that the cylinder, A, may be given a vertical motion, cords, M M, fixed to a piece, S, loose on the hub, D, wind round the drum of a windlass, T, after passing over the pulleys, p p.

The rapid gyratory motion of the cylinder, along with the erosive action of the metallic agglomerate, rapidly wears away the rock, and causes the descent of the perforator. During this operation a core of marble forms in the cylinder. This is

detached by lateral pressure, and is capable of being utilized. The tool descends at the rate of from 20 to 24 inches per hour, or from 8 to 10 yards per day in ordinary lime rock.—*Le Genie Civil*.

PORTABLE PROSPECTING DRILL.

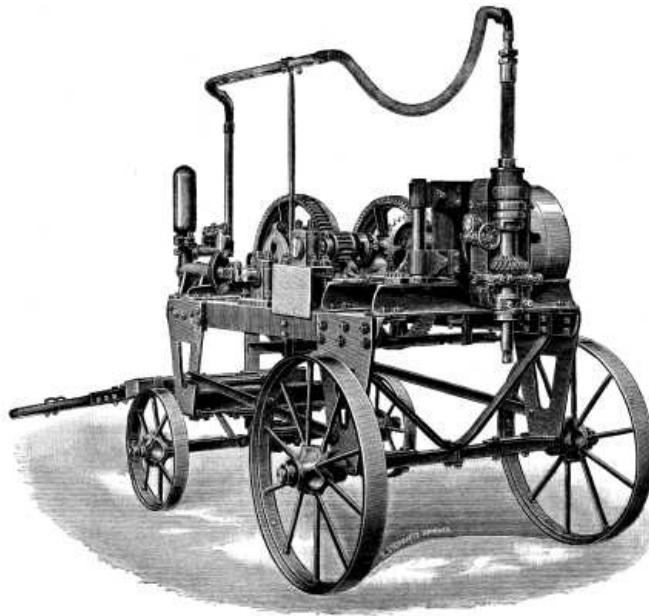

PORTABLE PROSPECTING DRILL.

The Aqueous Works and Diamond Rock-boring Company, Limited, of London, show at the Inventions Exhibition, London, a light portable rock-boring machine for prospecting for minerals, water, etc. It is capable of sinking holes from 2 in. to 5 in. in diameter, and to a depth of 400 ft. The screwed boring spindle, which is in front of the machine, is actuated by miter gearing driven by a six horse power engine; the speed of driving is 400 revolutions a minute. The pump shown on the left-hand side of the engraving is used to deliver a constant stream of water through the boring bar, the connection being made by a flexible hose. Suitable winding gear for raising or lowering the lining tubes, boring rods, etc., is also mounted on the same frame. The drill is automatic in its action, and the speed can be regulated by friction gearing. The front part of the carriage is arranged so that it can be swung clear of the drill to raise and lower the bore rods, etc.

AUTOMATIC SAFETY GEAR.

Among the safety appliances which are to be found in the Mining Section of the Inventions Exhibition is a model of an ingenious contrivance for the prevention of overwinding, the joint patent of Mr. W.T. Lewis, Aberdare, lead mineral agent to the Marquis of Bute, and W.H. Massey, electric light engineer to the Queen. Both these gentlemen, having been members of jury, were not allowed to compete for an award. The invention, says *Engineering*, seems to possess considerable merit, and it should prove of practical utility in collieries where enginemen are usually kept winding for many hours at a stretch, and where the slightest mistake on the part of the driver may lead to an accident.

Safety hooks are often fitted to winding ropes, and although the damage to life and property is greatly reduced by the use of them, they do not protect a descending cage from injury in a case of overwinding; besides which, they are almost useless when a wild run takes place, an accident which, strange to say, has already occurred many times after engines and boilers have been laid off for repairs. Stop valves are left open, the reversing lever is not fixed in mid-gear, steam is got up in the boilers at a time when no one is in the engine house, and the engines run away.

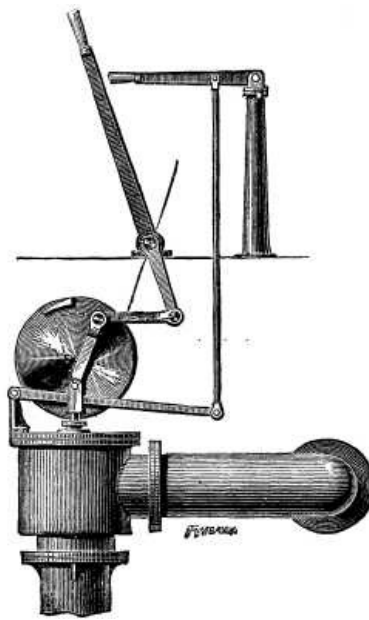

LEWIS & MASSEY'S AUTOMATIC SAFETY GEAR.

Various devices have been suggested and tried as a preventive, but their application has either caused as much mischief as a bad accident, or it has depended upon the driver doing something intentionally; whereas in the automatic gear of Messrs. Massey and Lewis, of which an illustration is annexed, there is nothing to cause damage or to interfere in any way with the proper handling of the engines, and it is practically out of the power of the driver to render the gear inoperative. It is here shown in its simplest form as applied to the ordinary reversing and steam handles of a winding engine, the only additions being an arm jointed to the top of the valve spindle, with its connections to the shaft of the reversing lever, and a disk receiving a suitable motion from the main shaft of the engine. On the disk is a projecting piece or stop which is brought into such positions, at or near the end of each journey, that the stop valve cannot be opened, except slightly, when the reversing lever is not set for winding in the proper direction, or when the cages have reached a point beyond which it is undesirable that the engine driver should have the power of turning on full steam. Thus, if one cage is at bank, the driver cannot draw it up into the head gear suddenly; but after it has been lifted slowly off the keeps or fangs, and the reversing lever thrown over, the stop valve can be lifted wide open; and supposing that while the engine is running the driver neglects to shut off steam in proper time, then the projecting piece on the disk in traveling round, slowly or quickly, and by steps according to requirements, will come in contact with the driver, and so prevent an accident by bringing the reversing lever into or beyond mid-gear.

Messrs. Lewis and Massey contemplate the use of governors in combination with various forms of their automatic gear, so as to provide for every imaginable case of winding, and also to avoid accidents when heavy loads are sent down a pit; the special feature in their mechanism being that when two or more things happen with regard to the positions of steam or reversing handles, speed or position of cages in the pit, whatever it may be necessary to do to meet the particular case shall be done automatically.

THE WATER SUPPLY OF ANCIENT ROMAN CITIES. ⁴

As the supply of water to large populations is one of the most important subjects in connection with sanitary matters, and one upon which the health of the populations to a very large extent depends, I propose to give a short account of some of the more important works carried out for this purpose by the ancient Romans—the great sanitary engineers of antiquity—more especially as I have had exceptional opportunities of examining many of those great works in Italy, in France, and along the north coast of Africa. Of the aqueducts constructed for the supply of Rome itself we have an excellent detailed account in the work of Frontinus, who was the controller of the aqueducts under the emperor Nerva, and who wrote his admirable work on them about A.D. 97.

It may be interesting in passing to mention that Frontinus was a patrician, who had commanded with distinction in Britain under the emperor Vespasian, before he was appointed by the emperor Nerva as controller (or, we should say, surveyor) of the aqueducts. He was also an antiquarian, and in his work he not only describes the aqueducts as they were in this time, but also gives a very interesting history of them.

He begins by telling us that for 441 years after the building of the city—that is to say, B.C. 312—there was no systematic supply of water to the city; that the water was got direct from the Tiber, from shallow wells, and from natural springs; but that these sources were found no longer to be sufficient, and the construction of the first aqueduct was undertaken during the consulship of Appius Claudius Crassus, from whom it took the name of the Appian aqueduct. This was, as may be expected from its being the first aqueduct, not a very long one; the source was about eight miles to the east of Rome, and the length of the aqueduct itself rather more than eleven miles, according to Mr. James Parker, to whose paper on the "Water Supply of Ancient Rome" I am indebted for many of the facts concerning the aqueducts of Rome itself. This aqueduct was carried underground throughout its whole length, winding round the heads of the valleys in its course, and not crossing them, supported on arches, after the manner of more recent constructions; it was thus invisible until it got inside the city itself, a very important matter when we consider how liable Rome was, in these early times, to hostile attacks.

It was soon found that more water was required than was brought by this aqueduct, and it was no doubt considered desirable to have tanks at a higher level in the city than those supplied by the Appian aqueduct. It was determined, therefore, to bring water from a greater height, and from a greater distance, and the river Anio, above the falls at Tivoli, was selected for this purpose. The second aqueduct, the Anio Vetus, was no less than 42 miles in length, and was, like the Appian, entirely under the surface of the ground, except at its entrance into Rome at a point about 60 ft. higher than the level of the Appian aqueduct.

Little search has been made for the remains of this aqueduct, and its exact course is not known; but during my examination of the remains of the subsequent aqueducts at a place called the Porta Furba, near Rome, where the ruins of five aqueducts are seen together, and at, or close to, which point the Anio Vetus must also have passed underground, I was rewarded for my search by discovering a hole, something like a fox's hole, leading into the ground; and on clearing away a few loose stones which had apparently been thrown into it, and putting my arm in, I found that it led into the specus or channel of an underground aqueduct; and on relating this incident to the late Mr. John Henry Parker, the antiquarian, who was then in Rome, and showing him a sketch of the place, he said that he had no doubt that I had been fortunate enough to discover the exact position of the veritable Anio Vetus at that spot. These two aqueducts sufficed for the supply of Rome with water for about 120 years, for Frontinus tells us that 127 years after the date at which the construction of the Anio Vetus was undertaken—that is to say, the 608th year after the foundation of the city—the increase of the city necessitated a more ample supply of water, and it was determined to bring it from a still greater distance. It was no longer considered necessary to conceal the aqueduct underground during the whole of its course, and so it was in part carried above ground on embankments or supported upon arches of masonry. The water was brought from some pools in one of the valleys on the eastern side of the Anio, some miles farther up than the point from which the Anio Vetus was supplied; and the new aqueduct, which was 54 miles in length, was called the Marcian, after the Prætor Marcius, to whom the work was intrusted. Frontinus also tells us the history of the other six aqueducts which were in existence in his time, viz., the Tepulan, the Julian, the Virgo, the Alsietine or Augustan, the Claudian, and the Anio Novus; the last two being commenced by the Emperor Caligula, and finished by Claudius, because "seven aqueducts seemed scarcely sufficient for public purposes and private amusements;" but it is not necessary for our purpose to give any detailed account of the course of these aqueducts; it is only necessary to mention one or two very interesting points in connection with them. In order to allow of the deposit of suspended matters, piscinæ, or settling reservoirs, were constructed in a very ingenious manner. Each had four compartments, two upper and two lower; the water was conducted into one of the upper compartments, and from this passed, probably by what we should call a standing waste or overflow pipe, into the one below; from this it passed (probably through a grating) into the third compartment at the same level, and thence rose through a hole in the roof of this compartment into the fourth, which was above it, and in which the water, of course, attained the same level as in the first compartment, thence passing on along the aqueduct, having deposited a good deal of its suspended matter in the two lower compartments of the piscinæ. Arrangements were made by which these two lower compartments should be cleaned out from time to time. The specus or channel itself was, of course, constructed of masonry, generally of blocks of stone cemented together, and it was frequently, though not, it would appear always, lined with cement inside. It was roofed over, and ventilating shafts were constructed at intervals; in order to encourage the aeration of the water, irregularities were occasionally introduced in the bed of the channel. The water supplied by the different aqueducts was of various qualities; thus, for instance, that of the Alsietine, which was taken from a lake about 18 miles from Rome, was of an inferior quality, and was chiefly used to supply a large naumachia, or reservoir, in which imitation sea fights were performed; while, on the other hand, the water of the Marcian was very clear and good, and was therefore used for domestic purposes. Frontinus gives the most accurate details as to the

measurements of the amount of water supplied by the various aqueducts, and the quantities used for different purposes. From these details Mr. Parker computes the sectional area of the water at about 120 square feet, and says: "We can form some opinion of the vast quantity if we picture to ourselves a stream 20 ft. wide by 6 ft. deep constantly pouring into Rome at a fall six times as rapid as that of the river Thames." He considers that the amount was equivalent to about 332 million gallons a day, or 332 gallons per head per day, assuming the population of the city to be a million. When we consider that we in London have only 30 gallons a head daily, and that many other towns have less, we get some idea of the profusion with which water was supplied to ancient Rome. But the remains of Roman aqueducts are not only to be found near Rome. Almost every Roman city, whether in Italy or in the south of France, or along the north coast of Africa, can show the remains of its aqueduct, and almost the only things that are to be seen on the site of Carthage are the remains of the Roman water tanks and the ruins of the aqueduct which supplied them. The most beautiful aqueduct bridge in the world, on the course of the aqueduct which supplied the ancient Nemausus, now Nîmes, still stands, and is called, from the name of the department in which it is, the Pont du Gard. It consists of a row of large arches crossing the valley over which the water had to be carried, surmounted by a series of smaller arches, and these again by a series of still smaller ones, carrying the specus of the aqueduct. This splendid bridge still stands perfect, so that one can walk through the channel along which the water flowed, and it might be again used for its original purpose. There was, however, one city which, from the fact that a great part of it was situated upon a hill, was more difficult to supply with water than any of the rest, and which, at the same time, from its size, its great importance, and the fact that it was the favorite summer residence of several of the Roman emperors, and notably of Claudius, who was born there, and who had a palace on the top of the hill, must of necessity be supplied with plenty of water, and that too from a considerable height. I refer to Lugdunum (now Lyons), then the capital of Southern Gaul. This city was built by Lucius Munatius Plaucus, by order of the Senate in A.U.C. 711. Augustus went there in A.U.C. 738, and afterward lived there from 741 to 744. It was he who raised it to a very high rank among Roman cities. It had its forum near the top of the hill now called Fourvieres (probably a corruption of Forum Vetus), an imperial place on the summit of the same hill, public baths, an amphitheater, a circus, and temples.

In order to supply this city with water, standing as it did on the side of a hill at the junction of two great rivers (now Rhone and Saone), it was necessary to search for a source at a sufficient height, and this Plaucus found in the hills of Mont d'Or, near Lyons, where a plentiful supply of water was found at a sufficient height, viz., that of nearly 2,000 ft. above the sea. From this point an aqueduct, sometimes called from its source the aqueduct of Mont d'Or, and sometimes the aqueduct of Ecully, from the name of a large plain which it crossed, was constructed, or rather two subterranean aqueducts were made and joined together into one, which crossed the plain of Ecully, in a straight line still underground; but the ground around Lyons was not like the Campagna, near Rome, and it was necessary to cross the broad and deep valley now called La Grange, Blanche. This, however, did not daunt the Roman engineers; making the aqueduct end in a reservoir on one side of the valley, they carried the water down into the valley, probably by means of lead pipes, in the manner which will be described more at length further on, across the stream at the bottom of the valley by means of an aqueduct bridge 650 ft. long, 75 ft. high, and 28½ ft. broad, and up the other side into another reservoir, from which the aqueduct was continued along the top of a long series of arches to the reservoir in the city, after a course of about ten miles.

In the time of Augustus, however, it was found that the water brought by this aqueduct was not sufficient, especially in summer; and as there was a large Roman camp which also required to be supplied with water, situated at a short distance from the city, it was determined to construct a second aqueduct. For this purpose the springs at the head of a small river, called now the Brevenne, were tapped, and conveyed by means of an underground aqueduct (known as the aqueduct of the Brevenne) which wound round the heads of the valleys, and after a course of about thirty miles is believed by some to have arrived at the city, but by others to have stopped at the Roman camp, and to have been constructed exclusively for its supply.

I have here a diagram, after Flacheron, showing a section of this aqueduct, and this will give a very good general idea of the section of a Roman aqueduct where constructed underground. It will be seen that the specus or channel is 60 centimeters (or nearly 2 ft.) wide, and 1m. 57c. (or a little over 5 ft.) high, and that it is lined with a layer of 3 c. (or nearly 1¼ in.) of cement. It is constructed of quadrangular blocks of stone cemented together, and has an arched stone roof. It will be noticed also that the angles at the lower part of the channel are filled up with cement; it appears also that this aqueduct crossed a small valley by means of inverted siphons. But neither of these aqueducts came from a source sufficiently high to supply the imperial palace on the top of Fourvieres.

Their sources are, in fact, according to Flacheron, at a height of nearly 50 ft. below the summit of Fourvieres, and it was, therefore, considered necessary by the emperor Claudius to construct a third aqueduct. The sources of the stream now called the Gier, at the foot of Mont Pila, about a mile and a half above St. Chamond, were chosen for this purpose, and from this point to the summit of Fourvieres was constructed by far the most remarkable aqueduct of ancient times, an engineering work which, as will be seen from the following description, partly taken from Montfalcon's history of Lyons, partly from Flacheron's account of this aqueduct, and partly from my own observations on the spot, reflects the greatest possible credit on the Roman engineers, and shows that they were not, as has been frequently supposed by those who have only examined aqueducts at Rome, by any means ignorant of the elementary principles of hydraulics.

To tap the sources of a river at a point over 50 miles from the city, and to bring the water across a most irregular country, crossing ten or twelve valleys, one being over 300 ft. deep, and about two-thirds of a mile in width, was no easy task; but that it was performed the remains of the aqueduct at various parts of its course show clearly enough. It commences, as I have said, about a mile and a half from the present St. Chamond, a town on the river Gier, about 16 miles from St. Etienne. Here a dam appears to have been constructed across the bed of the river, forming a lake from which the water entered the channel of the aqueduct, which passed along underground until it came to a small stream which it crossed by a bridge, long since destroyed.

After this it again became subterranean for a time, and then crossed another stream on a bridge of nine arches, the ruins of some of the columns of which are still to be seen; and from these ruins it would appear that the bridge had, at some time or another, been destroyed, probably by the stream running under it having become torrential, and subsequently rebuilt; again it became concealed underground, to reappear in crossing a small valley and another small stream, when it was again concealed by the ground, and in one or two places channels were even cut for it through the solid rock, after which it reappeared on the surface at a point where now stands the village of Terre-Noire, and where it was necessary that it should somehow or another cross a broad and deep valley. It ended in a stone reservoir, from which eight lead pipes descending into the valley were carried across the stream at the bottom on an aqueduct bridge, about 25 ft. wide, and supported by twelve or thirteen arches, and then mounted the other side of the valley into another reservoir, of which scarcely any remains are now seen, from which the aqueduct started again, disappearing almost immediately under the surface of the ground, to appear again from time to time crossing similar valleys and streams upon bridges, the remains of some of which may still be seen, until it reached Soucieu, on the edge of the valley of the Garonne, where are still seen the remains of a splendid bridge, the thirteenth on its course, nearly 1,600 ft. long, and attaining a height of 56 ft. at its highest point above the ground. The object of this bridge was to convey the channel of the aqueduct at a sufficient height into a reservoir on the edge of the valley.

The remains of this bridge leave no doubt that it was purposely destroyed by barbarians; some of the arches near the end of it remain, while the rest have been thrown down, some on one side and some on the other; but happily the arches next to the reservoir, at the end of the bridge and on the edge of the valley, remain, and the reservoir itself is still in part intact, supported on a huge mass of masonry. Four holes are to be seen in that part of the front of the reservoir which is left, being the holes from which the lead pipes descended into the valley. There must have been nine of these pipes in all. These holes are elliptical in shape, being 12 in. high by 9½ in. wide, and the interior of the reservoir is still seen to be covered with cement. The walls of the reservoir were about 2 ft. 7 in. thick, and were strengthened by ties of iron; it had an arched stone roof in which there was an opening for access. From this the nine lead pipes descended the side of the valley supported on a construction of masonry, crossed the river by an aqueduct bridge, and ascended into another reservoir on the other side, entering the reservoir at its upper part just below the spring of the arches of the roof. From this reservoir the aqueduct passed to the next on the edge of the large and deep valley of Bonnan, being underground twice and having three bridges on its course, the last of which, the sixteenth on the course of the aqueduct, ends in a reservoir on the edge of the valley. Only one of the openings by which the siphons, of which there were probably ten, started from the reservoir is now left. The bridge across the valley below had thirty arches, and was about 880 ft. long by 24 ft. wide.

A number of the arches still remain standing, and, the pillars of the arches were constructed of transverse arches themselves. The work consisted of concrete, formed with Roman cement so hard that it turns the points of pickaxes when employed against it, with layers of tiles at regular intervals. The surface of the concrete is covered with small cubical blocks of stone placed so that their diagonals are horizontal and vertical, and forming what is known as *opus reticulatum*. After crossing the bridge the pipes were carried up the other side of the valley into a

reservoir, of which little remains, and then the aqueduct was continued to the next valley, passing over three bridges in its course. This valley, that of St. Irenée, is much smaller than either of the others, but nevertheless it was deep enough to necessitate the construction of inverted siphons, of which there were eight. Leaving the reservoir on the other side of this valley, the aqueduct was carried on a long bridge (the twentieth on its course) which crossed the plateau on the top of Fourvieres and opened into a large reservoir, the remains of which are still to be seen on the top of that hill.

From this reservoir, which was 77 ft. long and 51 ft. wide, pipes of lead conveyed the water to the imperial palace and to the other buildings near the top of the hill. Some of these lead pipes were found in a vineyard near the top of Fourvieres at the beginning of the eighteenth century, and were described by Colonia in his history of Lyons. They are made of thick sheet lead rolled round so as to form a tube, with the edges of the sheet turned upward, and applied to one another in such a way as to leave a small space, which was probably filled with some kind of cement. These pipes, of which it is said that twenty or thirty, each from 15 ft. to 20 ft. long, were found, were marked with the initial letters TI. CL. CAES. (Tiberius Claudius Cæsar), and afford positive evidence that the work was carried out under the emperor Claudius. Lead pipes, constructed in a similar manner, have also been found at Bath, in this country, in connection with the Roman baths. The great difference between this aqueduct and those near Rome arises from the fact that, instead of being carried across a nearly flat country, it was carried across one intersected with deep ravines, and that it was therefore necessary to have recourse to the system of inverted siphons. There can be no doubt that the inverted siphons were made of lead, although no remains of them have been found; for we know that the Romans used lead largely, and, as we have seen, pieces of the lead distribution pipes have been found. It is possible, and even likely, that strong cords of hemp were wound round the pipes forming the siphons, as is related by Delorme in describing a similar Roman aqueduct siphon near Constantinople; Delorme also describes, in the aqueduct last mentioned, a pipe for the escape of air from the lowest part of the siphon carried up against a tower, which was higher than the aqueduct, and it is certain that there must have been some such contrivance on the siphons of the aqueduct constructed at Lyons.

Flacheron supposes that they consisted of small pipes carried from the lowest part of the siphons up along the side of the valley and above the reservoirs, or, in some instances, of taps fixed at the lowest part of the siphons. The Romans have been blamed for not using inverted siphons in the aqueducts at Rome, and it has been said that this is a sufficient proof that they did not understand the simplest principles of hydraulics, but the remains of the aqueducts at Lyons negative this assumption altogether. The Romans were not so foolish as to construct underground siphons, many miles long, for the supply of Rome; but where it was necessary to construct them for the purpose of crossing deep valleys, they did so. The same emperor Claudius who built the aqueduct at Rome known by his name built the aqueduct of Mont Pila, at Lyons, and it is quite clear, therefore, that his engineers were practically well acquainted with the principles of hydraulics. It is thus seen that the ancient Romans spared no pains to obtain a supply of pure water for their cities, and I think it is high time that we followed their example, and went to the trouble and expense of obtaining drinking water from unimpeachable sources, instead of, as is too often the case, taking water which we know perfectly well has been polluted, and then attempting to purify it for domestic purposes.

[4]

An address by Prof. W.H. Corfield, M.D., M.A., delivered before the Sanitary Institute of Great Britain, July 9, 1885.—*Building News*.

STEAM ENGINE ECONOMY.

By Chief Engineer JOHN LOWE, U.S. Navy.

The purpose of this article is to point out an easy method whereby any intelligent engineer can determine the point at which it is most economical to cut off the admission of steam into his cylinder.

In the attack upon such a problem, it is useful to employ all the senses which can be brought to bear upon it; for this purpose, diagrams will be used, in order that the sense of sight may assist the brain in forming its conclusions.

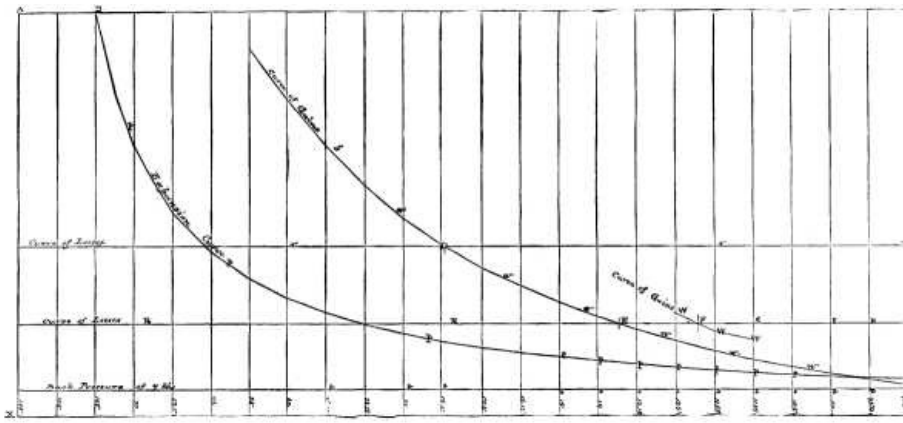

STEAM ENGINE ECONOMY.—BY JOHN LOWE, CHIEF ENGINEER U.S.N.

Fig. XABCX is an ideal indicator card, taken from a cylinder, imagined to be 600 feet long, in which the piston, making one stroke per minute, has therefore a piston speed of 600 feet per minute. Divide this card into any convenient number of ordinates, distant dx feet from each other, writing upon each the absolute pressure measured upon it from the zero line XX.

By way of example, let the diameter of the cylinder be 29.59 inches, and let the back pressure from all causes be 7 pounds uniformly throughout. It will be represented by the line b_1, b_2 , etc. This quantity subtracted from the pressures p_1, p_2 , etc., leaves the remainder $(p-b)$ upon each ordinate, which remainder represents the net pressures which at that point may be applied to produce external power.

If, now, A is the area of the piston, then the external power (dW) produced between each ordinate is:

To any convenient scale, upon each ordinate, set off the appropriate power as calculated by this equation (1).

$$dW = \frac{A(p-b)dx}{33,000} \quad (1.)$$

There will result the curve w, w, w , determining the power which at any point in the diagram is to be regarded as a gain, to be carried to the credit side of the account.

It is evident that, so long as the gains from expansion exceed the losses from expansion, it is profitable to proceed with expansion, but that expansion should cease at that point at which gains and losses just balance each other.

TO CALCULATE THE LOSSES.

The requisite data are furnished by the experiments conducted some years since by President D.M. Greene, of Troy College, for the Bureau of Steam Engineering, U.S. Navy.

According to these experiments, the heat which is lost per hour by radiation through a metallic plate of ordinary thickness, exposed to dry air upon one side and to the source of heat upon the other, for one degree difference in temperature, is as follows:

Condition.	Heat units.
Naked.....	2.9330672
Covered with hair felt, 0.25 inch thick....	1.0540710
" " 0.50 " 0.5728647
" " 0.75 " 0.4124625
" " 1.00 " 0.3070554
" " 1.25 " 0.2746387
" " 1.50 " 0.2507097

If now t' = temperature of steam at the ordinate,
 t = temperature of the surrounding atmosphere,
 dS = surface of the cylinder included between each ordinate,
 k = that figure from the table satisfying the conditions,
then the power loss (dR) per minute will be:

$$dR = \left(\frac{k}{60} \right) \frac{(t'-t)dS}{33,000} \quad (2)$$

To the same scale as the power gains, upon each ordinate, set off the appropriate

power loss, as calculated by this equation (2).

There will result the curve r, r, r , which determines the power which at any point in the diagram is to be regarded as a loss, to be carried to the debit side of the account. This curve of losses intersects the curve of gains at a point (it is evident) where each equals the other.

Therefore this is the point at which expansion should cease, and this absolute pressure is the economic terminal pressure, which determines the number of expansions profitable under the given conditions.

In the foregoing example are taken $k = 0.3070554$, $t' = 331.169$, $t = 60$, while the back pressure was taken at 7 pounds.

By way of further illustration, first let the back pressure be changed from 7 to 5.

By equation 1 there will result a new curve of gains, W, W, W , a portion only being plotted.

Second, let $t' = 331.169$ as before.
 $t = 150$ instead of 60.
 $k = 0.2507097$ instead of 0.3070554.

There will result the second curve of losses, R, R, R , intersecting the second curve of gains at the point F , the new economic point for our new conditions.

These two examples fully illustrate the whole subject, furnishing an easy and, when carefully made, a very exact calculation and result.

The following are a few of the general conclusions to be drawn:

1. That radiation is a tangible and measurable cause, sufficient to account for all losses heretofore ascribed to an intangible, immeasurable, and wholly imaginary cause, viz., "internal evaporation and re-evaporation."
2. In order to prevent the high initial temperatures now used becoming a source of loss, it is necessary to prevent the quantity $dS (t'-t)$ becoming great, by making dS as small as possible. In other words, we must compound our engines. Thus for the first time is pointed out the true reason why compound engines are economical heat engines.
3. The foregoing reasoning being correct, it follows that steam jackets are a delusion.
4. In order to attain economy, we must have high initial temperatures, small high pressure cylinders, low back pressures from whatsoever cause, high piston speeds, short rather than long strokes, to avoid the cooling effects of a long piston rod; but especially must we have scrupulous and perfect protection from radiation, especially about the cylinder heads, now oftentimes left bare.

ELECTRICITY IN WARFARE. [5](#)

By Lieut. B.A. FISKE, U.S.N.

Lieutenant Fiske began by paying a tribute to the remarkable pioneer efforts of Colonel Samuel Colt, who more than forty years ago blew up several old vessels, including the gunboat Boxer and the Volta, by the use of electricity. Congress voted Colt \$17,000 for continuing his experiments, which at that day seemed almost magical; and he then blew up a vessel in motion at a distance of five miles. Lieut. Fiske next referred briefly to the electrical torpedoes employed in the Crimean war and our civil war.

At the present day, an electrical torpedo may be described as consisting of a strong, water-tight vessel of iron or steel, which contains a large amount of some explosive, usually gun-cotton, and a device for detonating this explosive by electricity. The old mechanical mine used in our civil war did not know a friendly ship from a hostile one, and would sink either with absolute impartiality. But the electrical submarine mine, being exploded only when a current of electricity is sent through it from ship or shore, makes no such mistake, and becomes harmless when detached from the battery. The condition of the mine at any time can also be told by sending a very minute current through it, though miles away and buried deep beneath the sea.

When a current of electricity goes through a wire, it heats it; and if the current be made strong enough, and a white hot wire thus comes in contact with powder or fulminate of mercury in a torpedo, an explosion will result. But it is important to know exactly when to explode the torpedo, especially during the night or in a fog;

and hence torpedoes are often made automatic by what is called a circuit closer. This is a device which automatically bridges over the distance between two points which were separated, thus allowing the current to pass between them. In submarine torpedoes it is usual to employ a small weight, which, when the torpedo is struck, is thrown by the force of the blow across two contact points, one of which points is in connection with the fuse and the other in connection with the battery, so that the current immediately runs over the bridge thus offered, and through the fuse. In practice, these two contact points are connected by a wire, even when the torpedo is not in the state of being struck; but the wire is of such great resistance that the current is too weak to heat the wire in the fuse. Yet when the weight above mentioned is thrown across the two contact points, the current runs across the bridge, instead of through the resistance wire, and is then strong enough to heat the wire in the fuse and explode the torpedo. The advantage of having a wire of high resistance between the contact points, instead of having no wire between them, is that the current which then passes through the fuse, though too weak to fire it, shows by its very existence to the men on shore that the circuit through the torpedo is all right.

But instead of having the increased current caused by striking the torpedo to fire the torpedo directly, a better way is to have it simply make a signal on shore. Then, when friendly vessels are to pass, the firing battery can be disconnected; and when the friendly ship bumps the torpedo, the working of the signal shows not only that the circuit through the fuse is all right, but also that the circuit closer is all right, so that, had the friendly ship been a hostile ship, she would certainly have been destroyed.

While the management of the torpedo is thus simple, the defense of a harbor becomes a complex problem, on account of the time and expense required to perfect it, and the training of a corps of men to operate the torpedoes.

In order to detect the presence of torpedoes in an enemy's harbor, an instrument has been invented by Capt. McEvoy, called the "torpedo detector," in which the action is somewhat similar to that of the induction balance, the iron of a torpedo case having the effect of increasing the number of lines of force embraced by one of two opposing coils, so that the current induced in it overpowers that induced in the other, and a distinct sound is heard in a telephone receiver in circuit with them. As yet, this instrument has met with little practical success, but, its principle being correct, we can say with considerable confidence that the reason of its non-success probably is that the coils and current used are both too small.

Lieut. Fiske described the spar torpedo and the various classes of movable torpedoes, including the Lay. His conclusion is that the most successful of the movable torpedoes is the Simms, with which very promising experiments have been conducted under the superintendence of Gen. Abbot.

Recent experiments in England have shown that the Whitehead torpedo, over which control ceases after it is fired, is not so formidable a weapon when fired at a ship *under way* as many supposed, for the simple reason that it can be dodged. But an electrical torpedo, over which control is exercised while it is in motion through the water, cannot be dodged, provided it receives sufficient speed. For effective work against ships capable of steaming fifteen knots per hour, the torpedo should have a speed of twenty knots. There is no theoretical difficulty in the way of producing this, for a speed of eleven knots has already been recorded, though an electric torpedo, to get this speed, would have to be larger than a Whitehead having the same speed. It may be conceived that a torpedo carrying 50 lb. of gun-cotton, capable of going 20 knots per hour, so that it would pass over a distance of 500 yards in about 45 sec., and yet be absolutely under control all the time, so that it can be constantly kept pointed at its target, would be a very unpleasant thing for an enemy to meet.

Military telegraphy is a second use of electricity in warfare. Lieut. Fiske traces its origin to our own civil war. Foreign nations took the hint from us, and during the invasion of France the telegraph played a most important part. In military telegraph trains, miles of wire are carried on reels in specially constructed wagons, which hold also batteries and instruments. Some of the wire is insulated, so that it can rest on the ground, and thus be laid out with great speed, while other wire is bare, and is intended to be put on poles, trees, etc. For mountain service the wires and implements are carried by pack animals. Regularly trained men are employed, and are drilled in quickly running lines, setting up temporary stations, etc. In the recent English operations in Egypt, the advance guard always kept in telegraphic communication with headquarters and with England, and after the battle of Tel-el-Kebir news of the victory was telegraphed to the Queen and her answer received in forty-five minutes.

The telephone is also used with success in warfare, and in fact sometimes assists the telegraph in cases where, by reason of the haste with which a line has been run, the current leaks off. A telephone may then be used to receive the message—and for a transmitter a simple buzzer or automatic circuit breaker, controlled by an ordinary

key. In the case of vessels there is much difficulty in using the telegraph and the telephone, as the wire may be fouled and broken when the ship swings by a long chain. In England in the case of a lightship this difficulty has been surmounted, or rather avoided, by making hollow the cable by which the ship rides, and running an insulated wire along the long tube thus formed inside. But the problem is much simplified when temporary communication only is desired between ships at anchor, between a ship and the shore, or even between a ship and a boat which has been sent off on some special service, such as reconnoitering, sounding, etc. In this case portable telephones are used, in which the wire is so placed on a reel in circuit with the telephone that communication is preserved, even while the wire is running off the reel.

The telegraph and telephone are both coming largely into use in artillery experiments, for example, in tracking a vessel as she comes up a channel so that her exact position at each instant may be known, and in determining the spot of fall of a projectile. In getting the time of flight of projectiles electricity is of value; by breaking a wire in circuit with a chronograph, the precise instant of start to within a thousandth of a second being automatically registered. Velocimeters are a familiar application of electricity somewhat analogous. In these, wires are cut by the projectile at different points in its flight, and the breaking of the electric current causes the appearance of marks on a surface moving along at a known speed. The velocity of the projectile in going from one wire to another can then be found.

Electricity is also used for firing great guns, both in ships and forts. In the former, it eliminates the factor of change produced by the rolling of the ship during the movement of the arm to fire the gun. The touch of a button accomplishes the same thing almost instantaneously. Moreover, an absolutely simultaneous broadside can be delivered by electricity. The officer discharges the guns from a fighting tower, whither the wires lead, and the men can at once lie down out of the enemy's machine guns, as soon as their own guns are ready for discharge. The electric motor will certainly be used very generally for handling ordnance on board ships not very heavily plated with armor, since a small wire is a much more convenient mode of conveying energy to a motor of any kind, and is much less liable to injury, than a comparatively large pipe for conveying steam, compressed air, or water under pressure. Besides, the electric motor is the ideal engine for work on shipboard, by reason of its smooth and silent motion, its freedom from dirt and grease, the readiness with which it can be started, stopped, and reversed, and its high efficiency. Indeed, in future we may look to a protected apparatus for all such uses in every fort and every powerful ship.

In photographing the bores of great guns, electric lights are used, and they make known if the gun is accurately rifled and how it is standing the erosion of the powder gases.

In the case of a fort, electricity can be employed in connection with the instruments used for determining at each instant the position of an approaching vessel or army. Whitehead torpedoes are now so arranged that they can be ejected by pressing an electric button.

Electric lights for vessels are now of recognized importance. At first they were objected to on the ground that if the wire carrying the current should be shot away in action, the whole ship would be plunged in darkness; and so it would be in an accident befalling the dynamo that generates the current. The criticism is sensible, but the answer is that different circuits must be arranged for different parts of the ship, and the wires carrying the current must be arranged in duplicate. It is also easy to repair a break in a copper wire if shot away. As to the dynamo and engines, they must be placed below the water line, under a protective deck, and this should be provided for in building the vessel. There should be several dynamos and engines. All the dynamos should, of course, be of the same electromotive force, and feed into the same mains, from which all lamps draw their supply, and which are fed by feeders from the dynamo at different points, so that accident to the mains in one part of the ship will affect that part only. But it is the arc light, used as what is called a search light, that is most valuable in warfare. Lieut. Fiske thinks its first use was by the French in the siege of Paris, to discover the operations of the besiegers. It can be carried by an army in the field, and used for examining unknown ground at night, searching for wounded on the battle field, and so on. On fighting vessels the search light is useful in disclosing the attack of torpedo boats or of hostile ships, in bringing out clearly the target for guns, and in puzzling an enemy by involving him successively in dazzling light and total darkness. Lieut. Fiske suggests that this use would be equally effective in embarrassing troops groping to the attack of a fort at night by sudden alternations of blinding light and paralyzing darkness. There should be four search lights on each side of a ship.

As to the power and beauty of the search light, Lieut. Fiske refers to the magnificent one with which he lighted up Philadelphia last autumn, during the electric exhibition in that city. One night he went to the tower of the Pennsylvania railroad station and

watched the light stationed at the Exhibition building on 32d street. The ray of light when turned at right angles to his direction looked like a silver arrow going through the sky; and when turned on him, he could read the fine print of a railroad time table at arm's length. Flashes from his search light were seen at a distance of thirty miles.

In using incandescent lamps for night signaling, the simplest way is to arrange a keyboard with keys marked with certain numbers, indicating the number of lamps arranged in a prominent position, which will burn while that key is being pressed. For example, suppose the number 5348 means "Prepare to receive a torpedo attack." Press keys 5, 3, 4, 8, and the lights of lamps 5, 3, 4, 8, successively blaze out.

Electrical launches have been used to some extent, their storage batteries being first charged ashore or on board the ship to which the launch belongs. They have carried hundreds of people, and have made eight knots an hour. The improvement of storage batteries, steadily going on, will eventually cause the electrical launch to replace the steam launch. One of its advantages is in having no noise from an exhaust and no flame flaring above a smoke pipe to betray its presence. In warfare two sets of storage batteries should be provided for launches, one being recharged while the other is in use.

Mr. Gastine Trousse has recently invented "an electric sight," a filament of fine wire in a glass tube covered with metal on all sides save at the back. The battery is said to be no larger than a man's finger, and to be attached to the barrel near the muzzle by simple rubber bands, so arranged that the act of attaching the battery to the barrel automatically makes connection with the sight; and so arranged also that the liquid of the battery is out of action except when the musket is brought into a horizontal position for firing.

To throw a good light upon the target the same inventor has devised a small electric lamp and projector, which is placed on the barrel near the muzzle by rubber bands, the battery being held at the belt of the marksman, with such connections that the act of pressing the butt of the musket against the shoulder completes the circuit, and causes the bright cylinder of light to fall on the target, thus enabling him to get as good a shot as in the day time.

Search lights and incandescent lights are advantageously used with balloons. In submarine boats electricity will one day be very useful. Submarine diving will play a part in future wars, and the diver's lamp will be electrical.

Progress has been made also in constructing "electrical guns," in which the cartridge contains a fuse which is ignited by pressing an electric button on the gun. A better aim can be had with it, when perfected, than with one fired by a trigger. At present, according to Lieut. Fiske, this invention has not reached the practical stage, and the necessity for a battery to fire a cartridge is decidedly an objection. But the battery is very small, needs little care, and will last a long time. The hard pull of the ordinary trigger causes a movement of the barrel except in the hands of the most highly skilled marksmen, and this hard pull is a necessity, because the hammer or bolt must have considerable mass in order to strike the primer with sufficient force to explode it. Having the mass, it must have considerable inertia; hence it needs a deep notch to hold it firm when jarred at full cock, and this deep notch necessitates a strong pull on the trigger. But with an electric gun the circuit-closing parts are very small and light, and can be put into a recess in the butt of the gun, out of the way of chance blows. Thus a light pressure of the finger is alone needed to fire it, while from the small inertia of the parts a sudden shock will not cause accidental closing of the circuit and firing of the gun.

[5]

From a recent lecture before the Franklin Institute, Philadelphia.

MEUCCI'S CLAIMS TO THE TELEPHONE.

Our readers have already been informed through these columns that, notwithstanding the refusal of the Attorney-General, Mr. Garland, to institute suit for the nullification of the Bell patent, application has again been made by the Globe Telephone Co., of this city, the Washington Telephone Co., of Baltimore, and the Panelectric Co. These applications have been referred to the Interior Department and Patent Office for examination, and upon their report the institution of the suit depends. The evidence which the companies above mentioned have presented includes not only the statement of Prof. Gray and the circumstances connected with his caveat, but brings out fully, for the first time, the claims of Antonio Meucci.

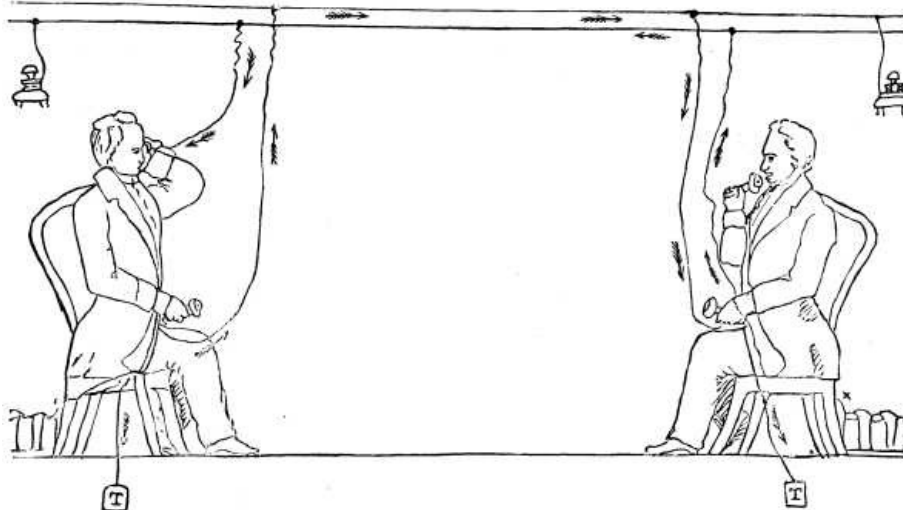

MEUCCI'S CAVEAT, 1871.

The latter evidence is intended to show that Meucci invented the speaking telephone not only before Bell, but that he antedated Reis by several years. In a recent interview with Meucci we obtained a brief history of his life and of his invention, which will, no doubt, interest our readers. Meucci, a native of Italy, was educated in the schools of Florence, devoting his time as a student to mechanical engineering. In 1844 he gave considerable attention to the subject of electricity, and had a contract with the government of the island of Cuba to galvanize materials used in the army. While experimenting with electricity he read the works of Becquerel, Mesmer, and others who treated largely of the virtues of electricity in the cure of disease. Meucci made experiments in this direction, and at one time thought that he heard the sound of a sick person's voice more distinctly than usual, when he had the spatula connected with the wire and battery in his mouth.

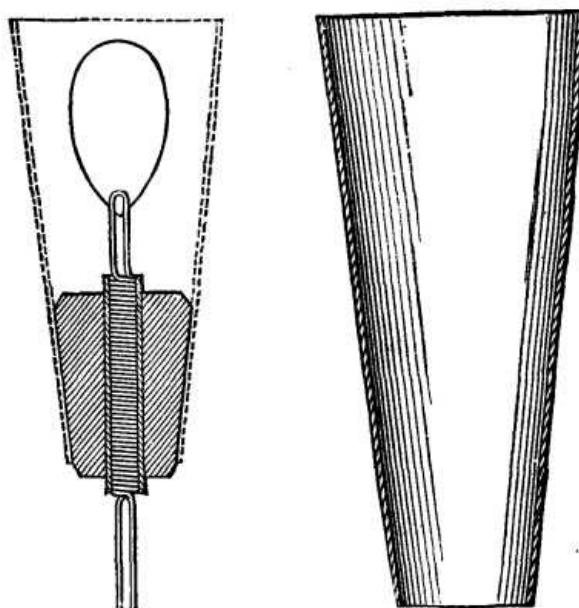

FIGS. 1 AND 2.—1849.

The apparatus he used for this purpose is shown in Fig. 1. It consists of an oval disk or spatula of copper attached to a wire which was coiled and supported in an insulating handle of cork. To ascertain that he was able to hear the sound, he covered the device with a funnel of pasteboard, shown in the adjoining figure, and held it to his ear, and thought that he heard the sound more distinctly.

These instruments were constructed in 1849 in Havana, where Meucci was mechanical director of a theater. In May, 1851, he came to this country, and settled in Staten Island, where he has lived ever since. It was not until a year later that he again took up his telephonic studies, and then he tried an arrangement somewhat different from the first. He used a tin tube, Figs. 3 and 4, and covered it with wire, the ends of which were soldered to the tongue of copper. With this instrument, he states, he frequently conversed with his wife from the basement of his house to the third floor, where she was confined as an invalid.

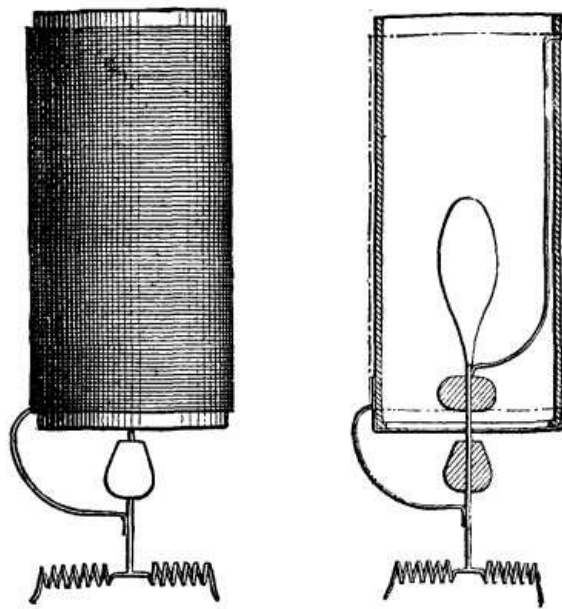

FIGS. 3 AND 4.—1852.

Continuing his experiments, he conceived the idea of using a bobbin of wire with a metallic core, and the first instrument he constructed on this idea is shown in Fig. 5. It consisted of a wooden tube and pasteboard mouth piece, and supported within the tube was a bundle of steel wires, surrounded at their upper end by a bobbin of insulated wire. The diaphragm in this instrument, was an animal membrane, and it was slit in a semicircle so as to make a flap or valve which responded to the air vibrations. This was the first instrument in which he used a bobbin, but the articulation naturally left much to be desired, on account of the use of the animal membrane. Meucci fixes the dates from the fact that Garibaldi lived with him during the years 1851-54, and he remembers explaining the principles of his invention to the Italian patriot.

After constructing the instrument just described, Meucci devised another during 1853-54. This consisted of a wooden block with a hole in the center which was filled with magnetic iron ore, and through the center of which a steel wire passed. The magnetic iron ore was surrounded by a coil of insulated copper wire. But an important improvement was introduced here in the shape of an iron diaphragm. With this apparatus greatly improved effects were obtained.

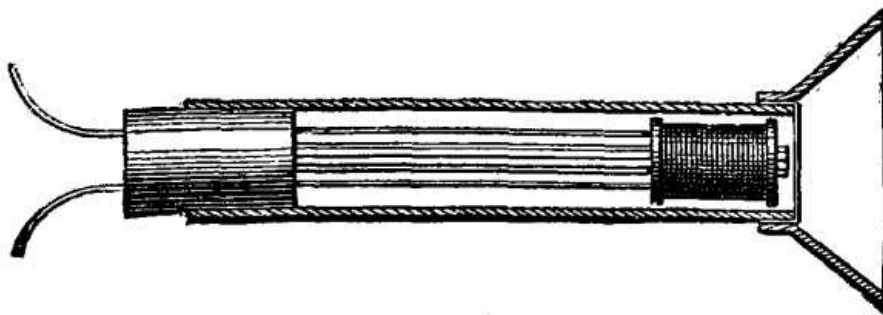

FIG. 5.—1853.

In 1856 Meucci first tried, he says, a horseshoe magnet, as shown in Fig. 6, but he went a step backward in using an animal membrane. He states that this form did not talk so well as some which he had made before, as might be expected.

During the years 1858-60 Meucci constructed the instrument shown in Fig. 7. He here employed a core of tempered steel magnetized, and surrounded it with a large coil. He used an iron diaphragm, and obtained such good results that he determined to bring his invention before the public. His national pride prompted him to have the invention first brought out in Italy, and he intrusted the matter to a Mr. Bendalari, an Italian merchant, who was about to start for that country. Bendalari, however, neglected the matter, and nothing was heard of it from that quarter. At the same time Meucci described his invention in *L'Eco d'Italia*, an Italian paper published in this city, and awaited the return of Bendalari.

Meucci, however, kept at his experiments with the object of improving his telephone, and several changes of form were the result. Fig. 8 shows one of these instruments constructed during 1864-65. It consisted of a ring of iron wound spirally with copper wire, and from two opposite sides iron wires attached to the core supported an iron

button. This was placed opposite an iron diaphragm, which closed a cavity ending in a mouthpiece. He also constructed the instrument which is shown in Fig. 9, and which, he says, was the best instrument he had ever constructed. The bobbin was a large one, and was placed in a soapbox of boxwood, with magnet core and iron diaphragm. Still seeking greater perfection, Meucci, in 1865, tried the bent horseshoe form, shown in Fig. 10, but found it no improvement; and, although he experimented up to the year 1871, he was not able to obtain any better results than the best of his previous instruments had given.

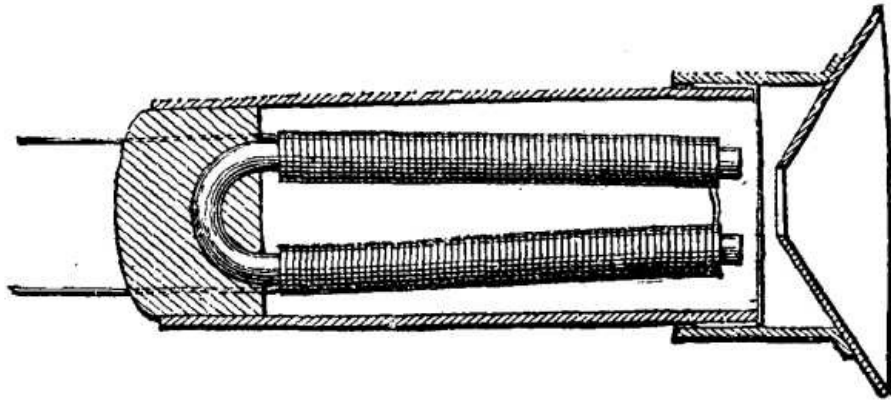

FIG. 6.—1856.

When Meucci arrived in this country, he had property valued at \$20,000, and he entered into the brewing business and into candle making, but he gradually lost his money, until in 1868 he found himself reduced to little or nothing. To add to his misery, he had the misfortune of being on the Staten Island ferryboat Westfield when the latter's boiler exploded with such terrible effect in 1871. He was badly scalded, and for a time his life was despaired of. After he recovered he found that his wife, in their poverty, had sold all his instruments to John Fleming, a dealer in second-hand articles, and from whom parts of the instruments have recently been recovered.

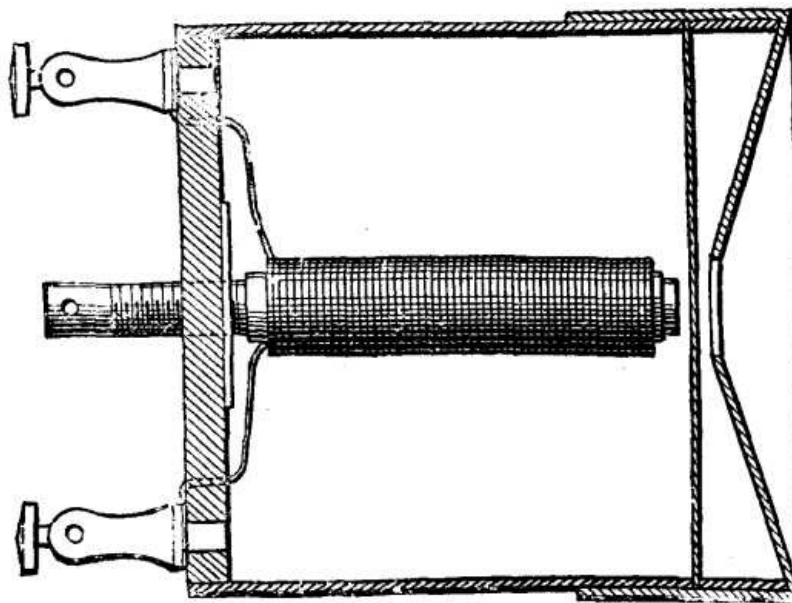

FIG. 7.—1858-60.

With the view of introducing his invention, Meucci now determined to protect it by a patent; and having lost his instrument, he had a drawing made according to his sketches by an artist, Mr. Nestori. This drawing he showed to several friends, and took them to Mr. A. Bertolino, who went with him to a patent attorney, Mr. T.D. Stetson, in this city. Mr. Stetson advised Meucci to apply for a patent, but Meucci, without funds, had to content himself with a caveat. To obtain money for the latter he formed a partnership with A.Z. Grandi, S.G.P. Buguglio, and Ango Tremeschin. The articles of agreement between them, made Dec. 12, 1871, credit Meucci as the inventor of a speaking telegraph, and the parties agree to furnish him with means to procure patents in this and other countries, and to organize companies, etc. The name of the company was "Teletrofono." They gave him \$20 with which to procure his caveat, and that was all the money he ever received from this source.

The caveat which Meucci filed contained the drawing made by Nestori, and as shown in the cut, which is a facsimile, represents two persons with telephones connected by wires and batteries in circuit. The caveat, however, does not describe the invention

very clearly; it describes the two persons as being insulated, but Meucci claims that he never made any mention of insulating persons, but only of insulating the wires. To explain this seeming incongruity, it must be stated that Meucci communicated with his attorney through an interpreter, as he was not master of the English language; and even at the present time he understands and speaks the language very poorly, so much so that we found it necessary to communicate with him in French during the conversation in which these facts were elicited.

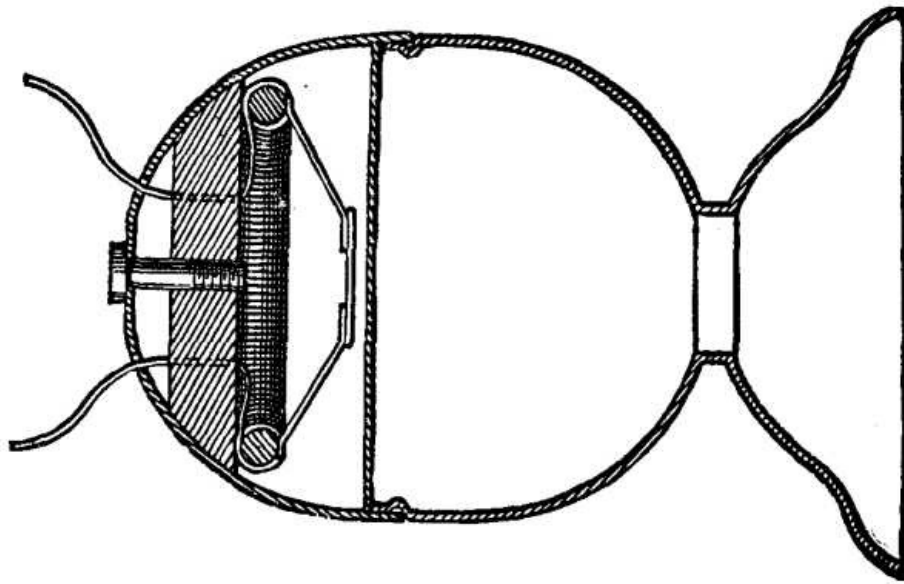

FIG. 8.—1864-65.

In the summer of 1872, after obtaining his caveat, Meucci, accompanied by Mr. Bertolino, went to see Mr. Grant, at that time the Vice President of the New York District Telegraph Company, and he told the latter that he had an invention of sound telegraphs. He explained his inventions and submitted drawings and plans to Mr. Grant, and requested the privilege of making a test on the wires of the company, which test if successful would enable him to raise money. Mr. Grant promised to let him know when he could make the test, but after nearly two years of waiting and disappointment, Mr. Grant said that he had lost the drawings; and although Meucci then made an instrument like the one shown in Fig. 9 for the purpose of a test, Mr. Grant never tried it. Meucci claims that he made no secret of his invention, and as instance cites the fact that in 1873 a diver by the name of William Carroll, having heard of it, came to him and asked him if he could not construct a telephone so that communication could be maintained between a diver and the ship above. Meucci set about to construct a marine telephone, and he showed us the sketch of the instrument in his memorandum book, which dates from that time and contains a number of other inventions and experiments made by him.

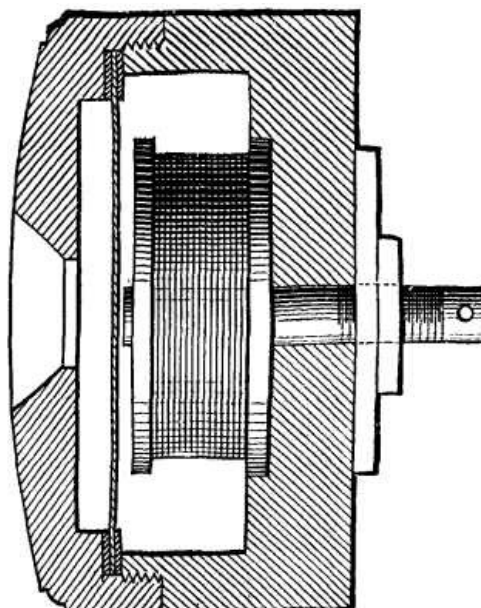

FIG. 9.—1864-65.

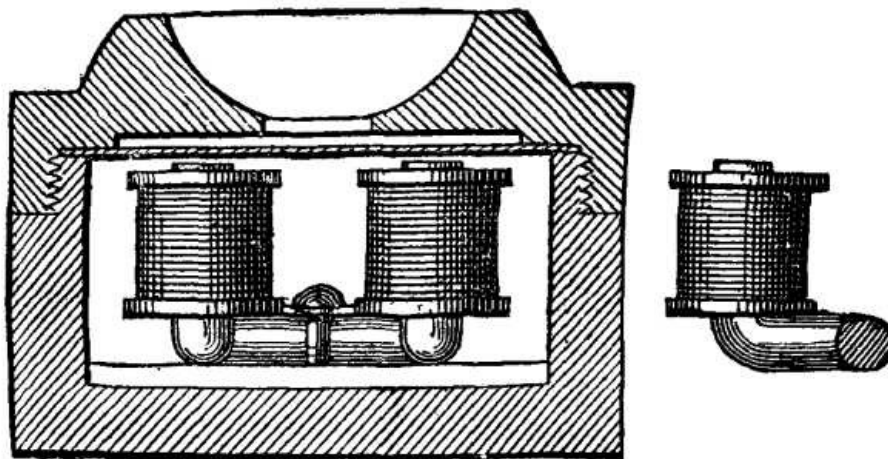

FIG. 10.—1865.

When Professor Bell exhibited his inventions at the Centennial, Meucci heard of it, but his poverty, he claims, prevented him from making his protestations of priority effective, and it was not until comparatively recently that they have been brought out with any prominence.—*The Electrical World*.

AN ELECTRICAL CENTRIFUGAL MACHINE FOR LABORATORIES.⁶

By ALEXANDER WATT, F.I.C., F.C.S.

The late Dr. Mohr⁷ of Bonn, advocated the use of a centrifugal machine as a means of rapidly drying crystals and crystalline precipitates; but although they are admirably adapted for that purpose, centrifugal machines are seldom seen in our chemical laboratories.

The neglect of this valuable addition to our laboratory apparatus is probably owing to the inconvenience involved in driving the machine at a high speed by means of the ordinary hand driving gear, especially when the rotation has to be maintained for a considerable length of time. It occurred to me, therefore, that by attaching the drum or basket of the machine (or the rotating table of Mohr's apparatus) directly to the spindle of an electro-motor, the difficulty of driving might be got over, and at the same time a combination of great efficiency would result, as the electro-motor, like the centrifugal machine, is most efficient when run at a high speed. The apparatus shown in the sketch consists essentially of a perforated basket, A, which is slipped on to a cone attached to the spindle, S, of an electro-motor, and held in position by the nut, D. The casing, B, with its removable cover, C, serves to receive the liquid driven out of the substance being dried. A flat form of the ordinary Siemens H armature, E, revolves between the poles, P, of the electro-magnets, M, which are connected by means of the base plate, I. The brass cross-bar, G, carries the top bearing of the spindle, S, and prevents the magnet poles from being drawn together.

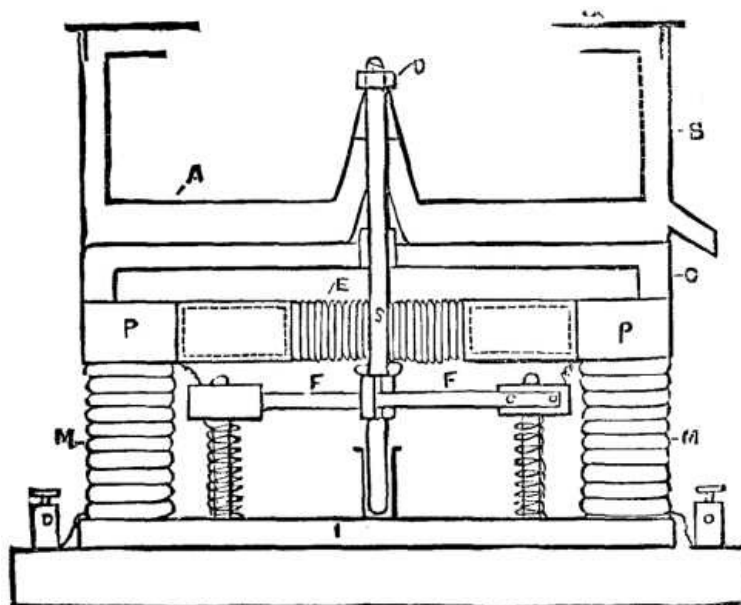

From four to six cells of a bichromate battery or Faure secondary battery furnish sufficient power to run the machine at a high speed. An apparatus with a copper basket four inches in diameter has been found extremely useful in the laboratory for drying such substances as granulated sulphate of copper and sulphate of iron and ammonia, but more especially for drying sugar, which when crystallized in very small crystals cannot be readily separated from the sirupy mother-liquor by any of the usual laboratory appliances. For drying substances which act on copper the basket may be made of platinum or ebonite; in the latter case, owing to the increased size of the perforations, it may be necessary to line the basket with platinum wire gauze or perforated parchment paper.

[6]

Paper read before Section B, British Association, Aberdeen meeting.

[7]

"Lehrb. d. Chem. Analyt. Titrimethode," 3d ed., 1870, p. 684.

TRANSMISSION OF POWER BY ELECTRICITY.

The experiments of M. Marcel Deprez have entered on a decisive phase. The dynamos are completed, and were put in place on the 20th October, when M. Deprez carried out some preliminary tests in the presence of a commission consisting of MM. Collignon, Inspector-General des Ponts et Chaussées; Delebecque, Ingenieur en Chef du Matériel et de la Traction of the Northern Railway of France; Contanini, engineer in the same company; and Sartaux. The generating dynamos made by MM. Breguet, and the receiving dynamos constructed by MM. Mignon and Rouart, were during a preliminary trial placed side by side, one portion of the circuit being very short, and the other twice the distance between La Chapelle and Creil, or seventy miles. In future experiments the two dynamos will be placed in their normal positions at each end of the line. The generating machine is driven by a locomotive engine; the resistance of its field magnets is 5.68 ohms, and of the two armatures 33 ohms. The resistance of the two armatures of the receiving machine is 36.8 ohms, and the resistance of the line is 97 ohms; the generator and receiver field magnets are excited each by a separate machine. Five different trials were made at varying speeds of the driving shaft; the initial work on this shaft was measured by a dynamometer, and the available energy of the shaft of the receiving machine was ascertained by a Prony brake; the other results of the experiments were deduced from the constants of the machines and from galvanometric measurements. For the first trials the different elements were as follows:

1. *Generating dynamos:*

Velocity of shaft	123 revolutions.
Electromotive force at terminals,	3370.25 volts.
" " total	3624.7 "
Available work at driving shaft.	43 h. p.
Electrical work of generator	37.38 "
Difference absorbed	5.62 "

2. *Line:*

Work absorbed by the line.	7.59 h. p.
----------------------------	------------

3. *Receiving dynamos:*

Velocity of shaft	154 revolutions.
Electromotive force at terminals,	2616.25 volts.
" " total	2336.94 "
Electrical work of receiver	24.10 h. p.
Available work on shaft	22.10 "
Difference absorbed	2 "

The duty obtained would thus be $22.10/43 = 51.3$ per cent., if the work absorbed by the exciting machines be not considered. Taking this into account, it would be reduced to 40 per cent.

In subsequent experiments the speed of the generator was increased gradually. In the last trial the following were the elements:

1. *Generating dynamos:*

Speed of shaft	190 revolutions.
Electromotive force at terminals	5231.25 volts.
" " total	5469.75 "
Available work on driving shaft,	62 h. p.
Electrical work on generator	53.59 "
Difference absorbed	8.51 "
Work absorbed by armature	2.33 "

2. <i>Line:</i>	
Work absorbed by conductors	7.21 h. p.
3. <i>Receiving dynamos:</i>	
Speed of shaft	248 revolutions.
Electromotive force at terminals	4508 volts.
Electromotive force total	4242.67 "
Electrical work of receiver	41.44 h. p.
Work measured on receiver shaft	35.8 "
Difference absorbed	5.64 "
Duty obtained, not including exciting machine	57 per cent.
Duty obtained, including exciting machine	48 "

During the various experiments the current traversing the line varied from 7.59 amperes to 7.21 amperes. No heating of any kind was observed.

M.J. Bertrand, who communicated a paper to the Academy of Sciences on the subject, commented on the relatively low speeds. It corresponds to a linear displacement of the surface armatures, in no case exceeding the speed of a locomotive wheel. The tension reached 5,500 volts., under very satisfactory mechanical conditions, and with a current that in no way endangered the line. This first experiment is certainly encouraging, and it will be followed by others of a more complete and exhaustive character. MM. De Rothschild are now embodying a powerful commission of French and foreign scientists who will follow the subject carefully, and report upon it. It may be safely predicted that one result of this action will be the development of a new series of observations of the highest technical interest and value.—*Engineering.*

THE LOCKED AND CORDED BOX TRICK.

The trick with the locked and corded box, I believe, is an old one, though perhaps not in its present form. In late years it has been revived with improvements, and popularized by those clever illusionists, Messrs. Maskelyne & Cook and Dr. Lynn, at the Egyptian Hall. There are several ways of working the trick or, rather, of arranging the special bit of mechanism wherein the peculiar features of the box consist. The one I am about to describe is, I think, the best of those I am acquainted with, or at liberty to divulge. Indeed, I don't know that any method is better, and this one has the advantage over most others of allowing the performer to get into as well as out of the box, without leaving a trace of his means of ingress. It will be seen the box is paneled, and all the panels look equally firm and fixed. As a matter of fact, one of the panels is movable, though the closest scrutiny would fail to discover this if the box and fittings are carefully made and adjusted. Fig. 1 shows the general appearance of the box, of which the back is the same as the front. In the box I describe, the end marked + has a movable panel. The size of the box should be regulated by the size of the performer; but one measuring 3 feet 6 inches long by 2 feet back to front, and 21 inches high, exclusive of the lid, which may be 3 inches, will be of general use. In making the box it is most important that all sides and panels look alike, and that nothing special in the appearance of the end with the loose panel should attract notice. Fig. 2 shows this end with fittings drawn half of full size, and it will be seen from this that the framing, A, is 3 inches wide by 1¼ inches thick, and the panel, B, ½ inch thick.

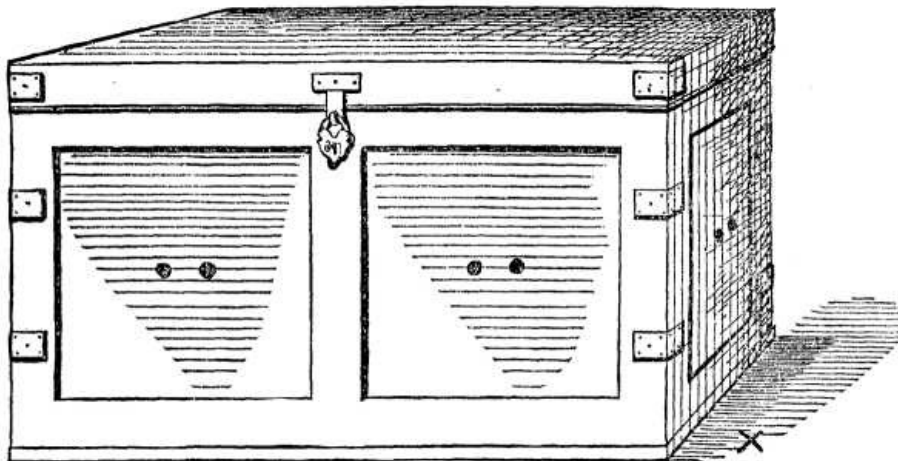
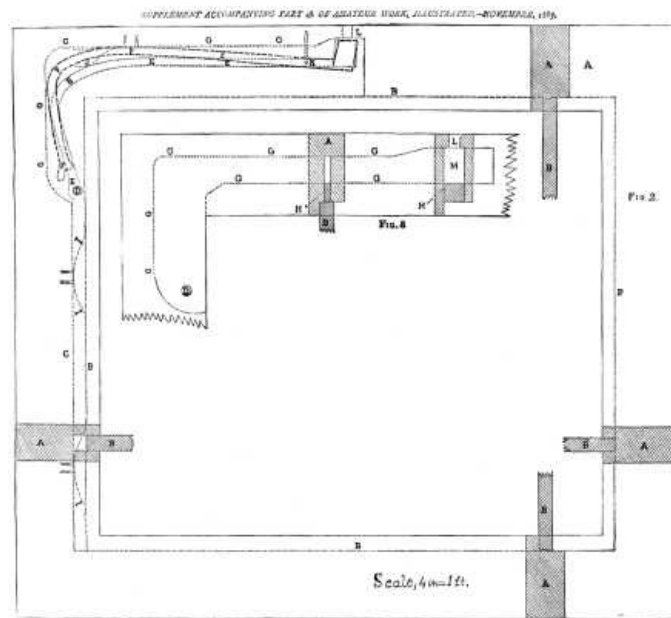

FIG. 1.

It will be noticed that the top and bottom rails of the frame are rabbeted to receive the panel, but the sides are grooved, the groove in front rail being double the depth of the one in the back rail.



THE LOCKED AND CORDED BOX TRICK. By DAVID B. ADAMSON.

The dotted line, B, shows the size of the panel; the dotted line, C, shows the depth of groove in the front rail. From this it will be clear that the panel is only held in place at the back and front, and that on sliding it toward the front it will be free out of the groove in the back rail. Three sides of it are thus free, and a little manipulation will allow of its being taken out altogether, leaving plenty of space for the performer to get out, presuming him to have been locked inside the box.

If the panel were to be finished in this way, without further fittings, the secret would soon be discovered; and I now proceed to show how the panel is held in place and firm while under examination.

Determine the size of screws that are to be used in fixing the brass corner clamps. Let us say No. 7 is decided on; and if brass screws are used, then get a piece of brass, Fig. 4, the exact diameter of the screw-head, and a little longer than the thickness of the framing. If iron screws are to be used, then this piece must be iron. Now bore a hole into which this bolt will fit closely, right through the framing at D, Fig. 2. It is most important that the hole should be made close up to the edge of the panel, B, so that when the bolt is in it firmly holds the panel, and prevents it moving from back to front in the grooving. Now get a piece of sheet brass, 1/8 inch thick, and cut it to the shape shown by E, Fig. 2. The width of this piece should not be less than 3/8 inch, and it must be of such length that the end reaches to the middle of the top framing, as shown at L, Fig. 2. This piece of brass is sunk in the top and front framing, as shown by the dotted lines, G, in Figs. 2 and 3, and also in section in the latter.

When the box is open, the lower or short arm of this lever, which is shaped as shown full size, at E, Fig. 8, is kept pressed down on the bolt, D, as shown by the dotted lines, E, E, E, Fig. 2, and E, Fig. 7, by of the spring, J, Fig. 2.

On the box being closed, a pin on the under edge of lid goes into the hole, L, Fig. 3, and presses the end of the lever down in such a way as to raise the claw end of it from D. The thick dotted lines, F, F, F, Fig. 2, show position of lever when box is closed.

It will be noted that the bolt, D, Fig. 4, has a groove cut in it all around, into which the claw fits. This prevents the bolt being pushed backward or forward when the box is open.

The lever must be hung as shown, K, Fig. 2. The exact position of this is immaterial, but it is as well to have the fulcrum as near the end as may be, in order that the claw may be raised sufficiently with only a small movement of the short arm of the lever. Of course, the shorter the arm is, the more accurately the lid and pin must be made to close.

If the pin, pressing short arm down, be too short, the pressure will not be enough to release the claw, and consequently the performer might find himself really unable to get out of the box after it is locked.

The end of the lever should be finished with a wood block, as Fig. 6, larger than the pin on the lid, as represented by L and M, Fig. 3.

The block may be of other material, but should be colored the same as the wood the

box is made of, so that, if any one were to look down on it, no suspicion would be aroused, as might be were plain brass used.

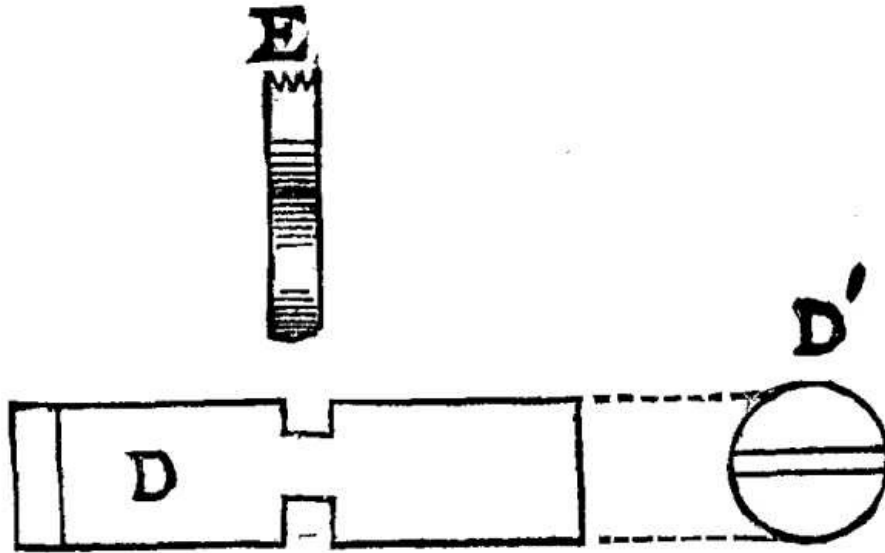

FIG 4.

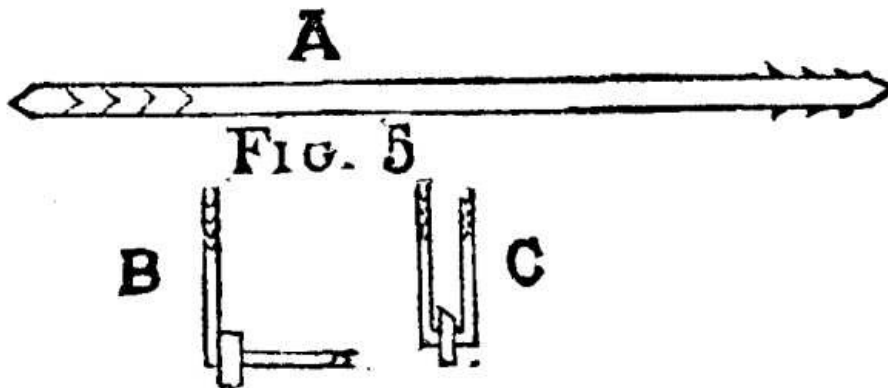

FIG 5.

In Fig. 5, I show an easy way of hanging the lever. It is simply a piece of wire sharpened and notched, so as to form several small barbs, preventing withdrawal. The mode of fixing will be easily understood by reference to B and C, Fig. 5. Some considerable amount of care will have to be bestowed on fitting and adjusting this part of the work, on which the successful performance of the trick consists, and before finally fixing up, it should be ascertained that all the movements work harmoniously. It will be best to cut the groove in which the lever works from below, and, after the lever is fixed, to fill up the space not required by the lever with strips of wood, H, H. If preferred, the space can be shaped out from the back, i.e., the inside of the framing, and then filled where not required, but as this, however neatly done, would show a joint which might be detected by sharp eyes, it is better to cut from below, though more troublesome.

The end containing the movable panel being arranged, make up the rest of the box to it, taking care to make the rebates of the top and bottom frames to correspond with those of the end.

The other panels should not, however, depend on the grooves on two sides only, but at tops and bottoms as well.

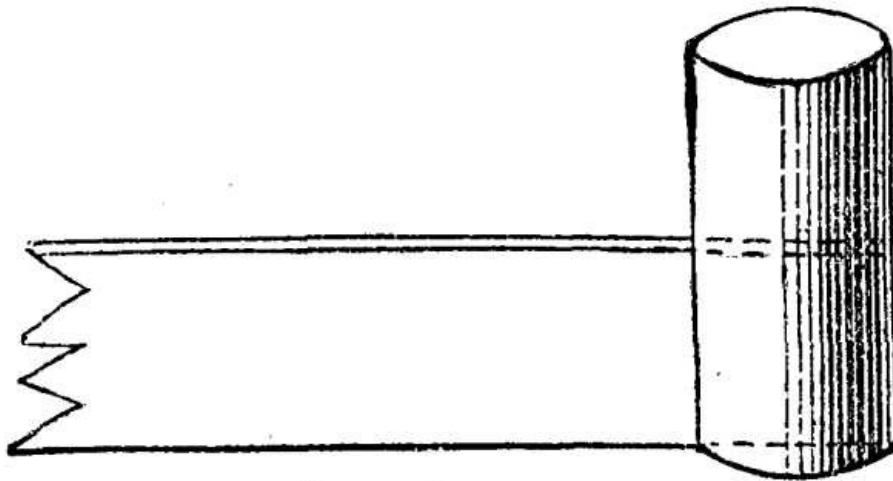

FIG. 6.

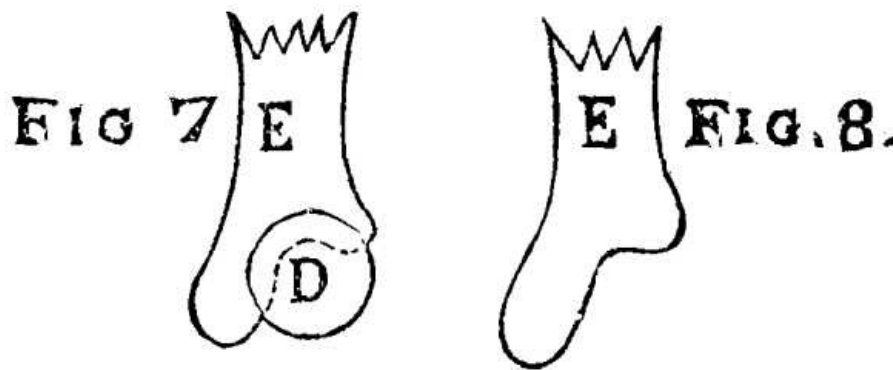

FIG. 7. & FIG. 8.

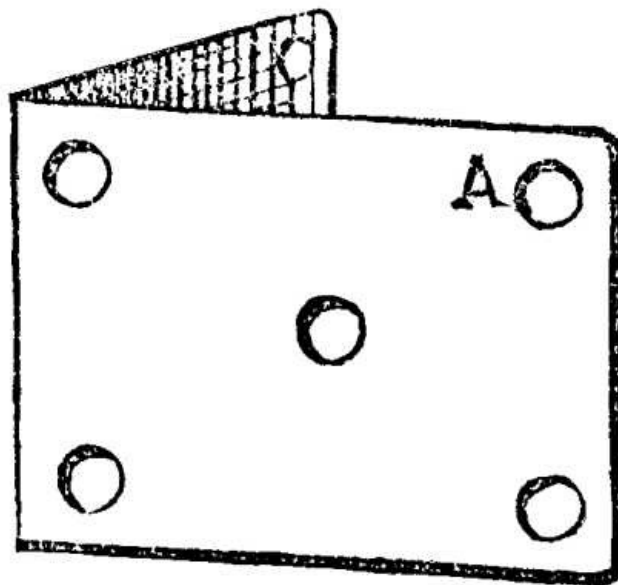

FIG. 9.

The rebates are to be cut only to have all the framing inside look alike; and as the panel, B, is made to fit quite close into the rebate, it will not be surmised that it is not fitted in the usual way.

After the box is made and fitted together, the clamping must be done. The only necessity for this is in order that the bolt, D, which we have seen is made on the outside end exactly to match the screws used to fasten the clamps, should not be conspicuous, as it would be were it alone. As it is, it will not be specially observable, being apparently only one of the screws to fasten the clamps.

The clamps may be of thin brass or iron, shaped as shown at Fig. 9. One of the corner holes must be arranged to cover D exactly, and the others regulated to it. Let us suppose that A, Fig. 9, is the one through which the bolt goes; the other corner screw holes must be equally distant from the edges of the clamps. Twelve of these clamps

will be needed. After they have been screwed on, put the bolt through, and let the claw of the lever hold it in place. Then mark and cut the bolt flush with the clamp, making a hollow on the end of it to imitate the screws, as D, Fig. 4. The other end of the bolt should either be made flush with the inside of frame and colored to match it, or, better, cut short and faced flush with a piece of wood to match the framing.

If a piece of wood with a knot be chosen for this side of the frame, so much the better. Immediately over the hole, L, a wooden pin should be fixed in the lid, and of such length that it will press the short arm of lever down sufficiently. It should fit the hole pretty closely.

At the other end, a corresponding pin and hole should be made, and, say, two along the front. These will then look as if they were intended merely as fittings to hold the lid in position. The lid at the other end of the box from the movable panel should have a stop of some sort; the ordinary brass joint stop will do as well as any, and should be strong. The reason for placing it at what I may call "the other end" is that, when the box is being examined, it will attract notice, and draw attention from the movable panel end.

We may now finally adjust the loose panel, which must fit tight at top and bottom, and be slightly beveled, as shown on section. Two holes must also be cut through it, at such a distance from each other that a finger and thumb can be put through them, so as to allow of the panel being moved. In the deep grooving in front also put a couple of springs, say pieces of clock springs, as shown, I, I, Fig. 2. These serve to assist the bolt, D, by pushing the panel into position.

Holes to match those in end panel must also be cut in the other panels, and when a lock, preferably a padlock, has been fitted, the box is complete.

I don't know whether it is necessary to say that the lid should be hinged at the back, and of course it will add to the appearance of the box if it be polished or oiled.

Now, for those who may not have seen the locked and corded box trick performed, a few words of caution may not be out of place. Don't forget to have something in a pocket easily got at that will serve to push the bolt out, before going into the box. A piece of stout wire, a small pencil case, or anything of that sort will do. Be careful when getting into the box to lie with your head toward the loose panel end, and face toward the front—as there will be no space to turn round; the right hand will then be uppermost and free to push the bolt out. Having done this, grasp the panel with the finger and thumb by means of the two holes, push it to the front of the box, when the back edge will be clear of the groove. It can now easily be pulled into the box, and the performer can creep out. When out, refix panel and bolt so that everything looks as it was. Any cording that may be over the end of the box will give sufficiently to allow of exit.

I have, I think, made it quite clear that padlock and ropes have nothing to do with the real performance of the trick, but they serve to mystify spectators, who may be allowed to knot the rope and seal the knots in any way they choose.

There must always be a screen or curtain to hide the box from the spectators while the performer is getting in or out.—*D.B. Adamson, in Amateur Work.*

PRICES OF METALS.

The *Metallarbeiter* remarks that metals have in most cases experienced a reduction in value of late years, this depreciation being attributed in some measure to the cheaper methods of obtaining metals as well as to the discovery of new sources of mineral wealth.

The following comparative table shows the approximate prices of various metals in December, 1874, and December, 1884:

	Dec., 1874.		Dec., 1884.
	Per lb.		Per lb.
	£ s d.		£ s d.
Osmium	71 10 0		62 0 0
Iridium	70 0 0		45 0 0
Gold	62 15 0		63 0 0
Platinum	25 7 6		21 7 6
Thallium	23 17 6		4 15 0
Magnesium	10 5 0		1 15 0
Potassium	5 0 0		4 0 0
Silver	3 17 6	(in Hamburg)	3 7 6
Aluminum	1 16 0		1 16 0
Cobalt	1 14 0		1 2 0
Sodium	0 14 2		0 8 8

Nickel	0 11 0		0 3 1
Bismuth	0 8 1		0 8 1
Cadmium	0 7 1		0 4 0
Quicksilver	0 2 0	(in London)	0 1 9
Tin	0 1 1	(in Berlin)	0 0 9
Copper	0 0 10	(" ")	0 0 7
Arsenic	0 0 8		0 0 4-1/2
Antimony	0 0 6-1/4	(" ")	0 0 5
Lead	0 0 2-3/4	(" ")	0 0 1-3/8
Zinc	0 0 2-1/2	(" ")	0 0 1-3/4
Steel	0 0 1-3/8	(in	0 0 0-3/4
Bar iron	0 0 1-1/8	Upper	0 0 0-5/8
Pig iron	0 0 0-7/16	Silesia)	0 0 0-1/4

Gold now ranks highest in value of all metals, the competition of osmium and iridium having been overcome. It is only by reason of improved methods of preparation that the latter have become cheaper, while their use has at the same time increased. Iridium is mixed with platinum in order to increase its strength and durability. The normal standards of the metrical system are made of platinum-iridium on account of its known immutability. In 1882, platinum stood 15 per cent. below its present value; but its increased employment for industrial purposes led to the subsequent improvement in price. Thallium has experienced a severe depreciation on account of the economical process by which it is extracted from the residue of the lead chambers used in the manufacture of sulphuric acid. The use of this metal is mainly confined to experimental purposes. The fall in silver has arisen from increased production and diminished use for coinage.

Magnesium was scarcely of any industrial value prior to the fall in price now recorded. Improved processes for its treatment have successfully engaged the attention of scientific men, and it is now capable of being used as an alloy with other metals. The Salindres factory regulates the price to a certain extent, and its system of working is regarded as a guide in the various processes connected with this branch of industry. The manufacture of potassium and sodium will, it is expected, be more fully elucidated than hitherto, by means of researches made at Schering's Charlottenburg factory. The course of nickel prices illustrates the stimulus to economical production afforded by an increased consumption. This latter fact is principally due to the employment of nickel for coinage, as alloy for alfenide, etc. The use of cadmium is materially restricted by its relatively limited supply. Hitherto, its only source was in the incidental products of zinc distillation, but of late it has been attempted to bring it into solution from its oxide combinations. An increased employment of cadmium for industrial purposes is expected to follow.

Production in excess of the demand has caused the depreciation recorded in tin, and various other metals not commented upon, this remark applying even to the scarce metals, arsenic and antimony. Even the better marks of Cornwall tin and Mansfield refined copper have had to follow the downward course of the market.

A PERPETUAL CALENDAR.

The annexed figure represents a perpetual calendar, which any one can construct for himself, and which permits of finding the day that corresponds to a given date, and conversely.

The apparatus consists of a certain number of circles and arcs of circles divided by radii. The ring formed by the two last internal circles is divided into 28 equal parts, which bear the names of the week, the first seven letters of the alphabet in reversed order, and two signs X. The circle formed by the external circumference of the ring constitutes the movable part of the apparatus, and revolves around its center. Two circular sectors, which are diametrically opposite, are each divided into seven parts and constitute the fixed portions. In the divisions of the upper sector are distributed the months, according to the order of the monthly numbers. In the other sector the days of the month are regularly distributed. In order to render the affair complete, a table is arranged upon the movable disk for giving the annual numbers, or rather, in this case, the annual letters. The calendar is used as follows: Say, for example, we wish to find what days correspond to the different dates of August, 1885; we look in the table for the letter (D) that corresponds to this year; then we bring this letter under the given month (August) and the days marked upon the movable disk corresponding to the dates sought, and it only remains to make a simple reading.

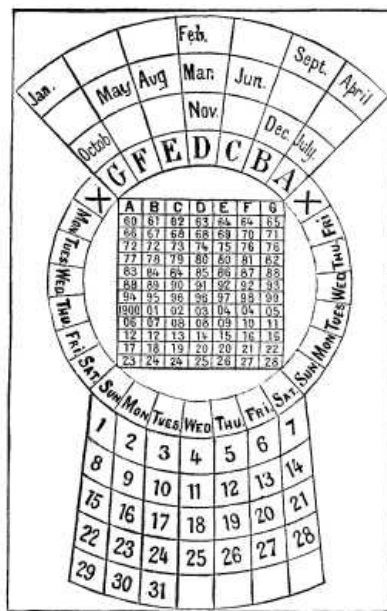

PERPETUAL CALENDAR.

It will be seen that the leap-years correspond to two letters. We here employ the first to Feb. 29 inclusive, and the second for the balance of the year. The calendar may be made of cardboard, and be fixed to wood.—*La Nature*.

AN ACCOMPLISHED PARROT.

Around the door of a Sixth Ave. bird store near Twenty-third St. was gathered the other day a crowd so large that it was a work of several minutes to gain entrance to the interior. From within there proceeded a hoarse voice dashed with a suspicion of whisky, which bellowed in Irish-American brogue the enlivening strains of "Peek-a-boo." With each reiteration of "Peek-a-boo" the crowd hallooed with delight, and one small boy, in the exuberance of his joy, tied himself into a sort of knot and rolled on the pavement. Suddenly the inebriated Irishman came to a dead stop, and another voice, pleasanter in quality, sang the inspiring national ode of "Yankee Doodle," followed by the stentorian query and answer all in one, "How are the Psi-Upsilon boys? Oh, they're all right!"

A passer-by, puzzled at the scene, made his way into the store and soon solved the mystery. In a large cage in the center was an enormous green and yellow parrot, which was hanging by one foot to a swinging perch, and troling forth in different voices with the ease of an accomplished ventriloquist. He resumed a normal position as he was approached, and flapping his wings bellowed out, "Hurrah for Elaine and Logan!" Then, cocking his head on one side, he dropped into a more conversational tone, and with a regular "Alice in Wonderland" air remarked: "It's never too late to mend a bird in the hand;" and again, after a pause, "It's a long lane that never won fair lady." His visitor affably remarked:

"You're quite an accomplished bird, Polly," and quick as a flash the creature replied:

"I can spell, I can. C-a-t, cat. D-o-g, fox," with an affectation of juvenility which was grewsome. He resented an ill-advised attempt at familiarity by snapping at the finger which tried to scratch his poll, and barked out:

"Take care! I'm a bad bird, I am. You betcher life!"

"He's one of the cleverest parrots I have had for some time," said his owner, Mr. Holden. "In fact, he is almost as good as Ben Butler, whom I sold to Patti. His stock of proverbs seems inexhaustible, and he makes them quite funny by the ingenious way in which he mixes them up. I could not begin to tell you all the things he says, but his greatest accomplishment is his singing. He is a double yellowhead—the only species of parrot which does sing. The African grays are better talkers, but they do not sing. They only whistle. What do I ask for him? Oh, I think \$200 is cheap for such a paragon, don't you?"—*N.Y. Tribune*.

THE ROSCOFF ZOOLOGICAL LABORATORY.

The celebrated Roscoff zoological station was founded in 1872, and has therefore been in existence for thirteen years; but it may be said that it has changed

appearance thirteen times. Those who, for the last six or seven years, have gone thither to work with diligence find at every recurring season some improvement or new progress.

A rented house, a small shed in a yard, little or no apparatus, and four work rooms—such was the debut of the station; and modest it was, as may be seen. Later on, the introduction of a temporary aquarium, which, without being ornamental, was not lacking in convenience, sufficed for making some fine discoveries regarding numerous animals.

A small boat served for supplying necessaries to the few workers who were then visiting Roscoff; but as the number of these kept gradually increasing, it became necessary to think of enlarging the station, and the purchase of a piece of property was decided upon. Since then, Mr. Lacaze Duthiers has done nothing but develop and transform this first acquisition. A large house, which was fitted up in 1879, formed the new laboratory. This was built in a large garden situated nearly at the edge of the sea. We say *nearly*, as the garden in fact was separated from the sea by a small road. The plan in Fig. 1 shows that this road makes an angle; but formerly it was straight, and passed over the terrace which now borders upon the fish pond. How many measures, voyages, and endless discussions, and how much paper and ink, it has taken to get this road ceded to the laboratory! Finally, after months of contest, victory rewarded Mr. Duthiers's tenacity, and he was then able to begin the construction of a pond and aquarium. All this was not done at once.

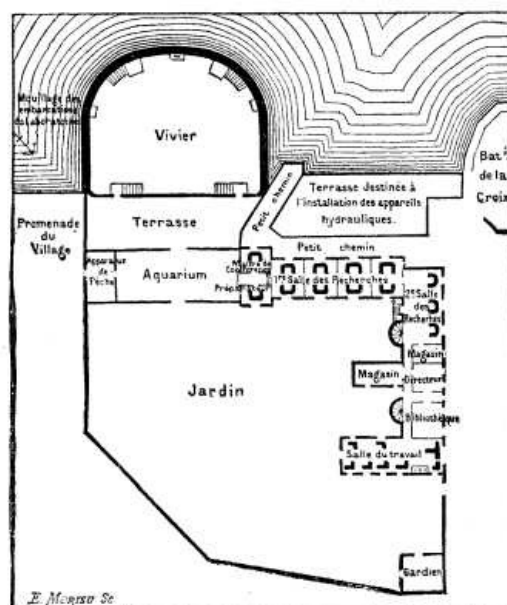

FIG. 1.—PLAN OF THE ROSCOFF LABORATORY.

Another capital improvement was made in 1882. The public school adjoining the establishment was ceded to it, the separating walls fell, the school became a laboratory, the class rooms were replaced by halls for research, and now no trace of the former separation can be seen—so uniform a whole does the laboratory form. No one knows what patience it required to form, piecemeal as it were, so vast an establishment, and one whose every part so completely harmonizes.

During the same year a park, one acre in area, was laid out on the beach opposite the laboratory. This is daily covered by the sea, and forms a preserve in which animals multiply, and which, during the inclement season, when distant excursions are impossible, permits of satisfying the demands that come from every quarter. All, however, is not finished. Last year a small piece of land was purchased for the installation of hydraulic apparatus for filling the aquarium. This acquisition was likewise indispensable, in order to prevent buildings from being erected upon the land and shutting off the light from the work rooms opposite. Alas, here we find our enemy again—the little road! Negotiations have been going on for eighteen months with the common council, and, what is worse, with the army engineers, concerning the cession of this wretched footpath.

The reader now knows the principal phases of the increases and improvements through which the Roscoff station has passed. If, with the plan before his eyes, he will follow us, we will together visit the various parts of the laboratory. The principal entrance is situated upon the city square, one of the sides of which is formed by the buildings of the station. We first enter a large and beautiful garden ornamented with large trees and magnificent flowers which the mild and damp climate of Roscoff makes bloom in profusion. We next enter a work room which is designed for those pupils who, doing no special work, come to Roscoff in order to study from nature

what has been taught them theoretically in the lecture courses of schools, etc. There is room here for nine pupils, to each of whom the laboratory offers two tables, with tanks, bowls, reagents, microscopes, and instruments of all kinds for cabinet study, as well as for researches upon animals on the beach. Here the pupils are in presence of each other, and so the explanations given by the laboratory assistants are taken advantage of by all. At the end of this room, on turning to the left, we find two large apartments—the library and museum. Here have been gradually collected together the principal works concerning the fauna of Roscoff and the English Channel, maps and plans useful for consultation, numerous memoirs, and a small literary library. The scientific collection contains the greater portion of the animals that inhabit the vicinity of Roscoff. To every specimen is affixed a label giving a host of data concerning the habits, method of capture, and the various biological conditions special to it. In a few years, when the data thus accumulated every season by naturalists have been brought together, we shall have a most valuable collection of facts concerning the fauna of the coast of France. Two store rooms at the end of these apartments occupy the center of the laboratory, and are thus more easy of access from the work rooms, and the objects that each one desires can be quickly got for him.

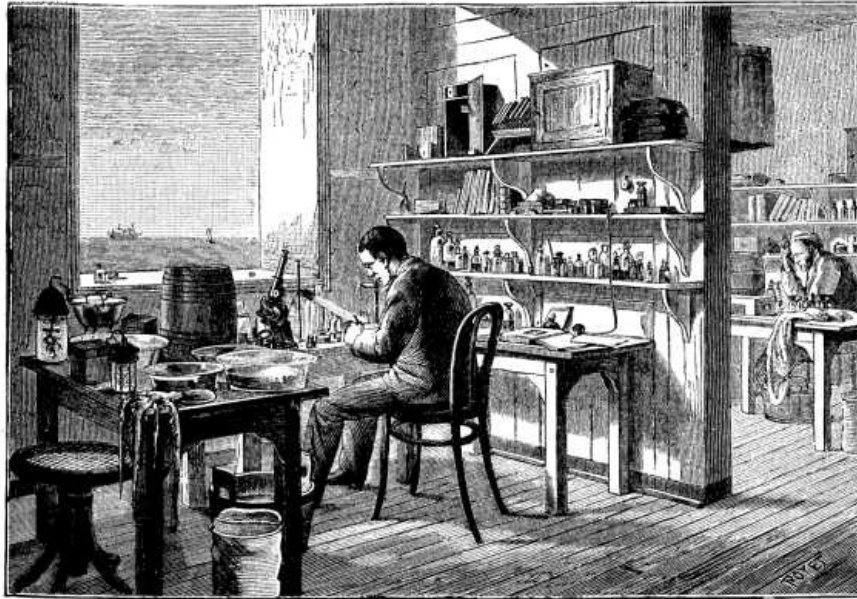

FIG. 2.—INTERIOR OF ONE OF THE STALLS FOR STUDY.

After the store rooms comes what was formerly the class room for boys, and which has space for three workers, and then the former girls' class room, which has space for eight more. Let us stop for a moment in this large room, which is divided up into eight stalls, each of which is put at the disposal of some naturalist who is making original researches. Fig. 2 represents one of these, and all the rest are like it. Three tables are provided, the space between which is occupied by the worker. Of these, one is reserved for the tanks that contain the animals, another, placed opposite a window giving a good light, supports the optical apparatus, and the last is occupied by delicate objects, drawings, notes, etc., and is, after a manner, the worker's desk. Some shelving, some pegs, and a small cupboard complete the stall. It is unnecessary to say that the laboratory furnishes gratuitously to those who are making researches everything that can be of service to them.

Four of these stalls are situated to the north, with a view of the sea, and the other four overlook the garden. They are separated from each other by a simple partition, and all open on a wide central corridor that leads to the aquarium. Before reaching the latter we find two offices that face each other, one of them for the lecturer and the other for the preparator. These rooms, as far as their arrangement is concerned, are identical with the stalls of the workers. The laboratory, then, is capable of receiving twenty-three workers at a time, and of offering them every facility for researches.

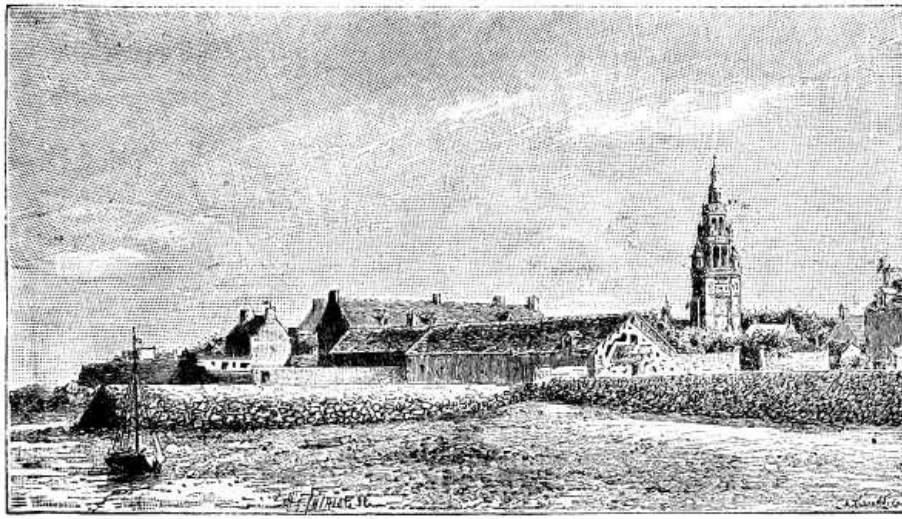

FIG. 3.—GENERAL VIEW OF THE ROSCOFF LABORATORY.

The aquarium is an immense room, 98 ft. in length by 33 in width, glazed at the two sides. It is at present occupied only by temporary tanks that are to be replaced before long by twenty large ones of 130 gallons capacity, and two oval basins of from 650 to 875 gallons capacity, constructed after the model of the one that is giving so good results at Banyuls. At the extremity of the aquarium there is a store room containing trawls, nets of all kinds, and mops, for the capture of animals. Here too is kept the rigging of the two laboratory boats, the *Dentale* and *Laura*. Above the store room is located the director's work room.

A wide terrace separates the aquarium from the pond. This latter is 38 yards long by 35 wide. Thanks to a system of sluice valves, it is filled during high tide, and the water is shut in at low tide, thus permitting of having a supply of living animals in boxes and baskets until the resources of the laboratory permit of a more improved arrangement. This basin is shown in Fig. 3. It is at the north side of the laboratory as seen from the beach. Here too we see the aquarium, the garden, and a portion of the shore that serves as a post for the station boats.

We must not, in passing, fail to mention the extreme convenience that the proximity of the aquarium work room to the pond and sea offers to the student.

This entire collection of halls, constituting the scientific portion of the laboratory, occupies the ground floor. The first and second stories are occupied by sleeping apartments, fourteen in number. These, without being luxurious, are sufficiently comfortable, and offer the great advantage that they are very near the work rooms, thus permitting of observing, at leisure, and at any hour of the day or night, the animals under study.

Everything is absolutely free at the laboratory. The work rooms, instruments, reagents, boats, dwelling apartments, etc., are put at the disposal of all with an equal liberality; and this absence of distinction between rich or poor, Frenchmen or foreigners, is the source of a charming cordiality and good will among the workers.

Shall we speak, too, of the richness of the Roscoff fauna? This has become proverbial among zoologists, as can be attested by the 265 of them who have worked at the laboratory. The very numerous and remarkable memoirs that have been prepared here are to be found recorded in the fourteen volumes of the *Archives de Zoologie Experimentale* founded by Mr. Lacaze Duthiers.

It only remains to express our hope that the aquarium may be soon finished; but before this is done it will be necessary to get possession of that unfortunate little road. After this final victory, Mr. Duthiers in his turn will be able, amid his pupils, to enjoy all those advantages of his work which he has until now offered to others, but from which he himself has gained no benefit.—*La Nature*.

THE MURÆNÆ AT THE BERLIN AQUARIUM.

Of all fish, eels are probably the most interesting, as the least is known of them. Electricians are now examining the animal source of electricity in the electric eel (*Gymnotus electricus*); zoologists are still searching for the solution of the problem of the generation of eels, of which no more is known than that the young eels are not born alive; and numerous fishing societies are now studying the important question of raising eels in ponds, lakes, etc., that are not connected with the sea.



THE MURÆNÆ AT THE BERLIN AQUARIUM.

The annexed cut, taken from the *Illustrirte Zeitung*, is a copy of a drawing by Muetzel, and represents a group of Mediterranean Murænæ (*Muræna Helena*). This fish attains a length of from 5 ft. to 6 ft., and has a smooth, scaleless body of a dark color, on which large light-yellow spots appear, which give the fish a very peculiar appearance. The pectoral fin is missing, but it has the dorsal and anal fins, which it uses with great ability. Its head is pointed, and its jaws are provided with extraordinarily sharp teeth, which are inclined toward the rear; and at each side of the head it is provided with a gill. The nostrils are on the upper side of the snout, and a second, tubular, pair of nostrils is located near the eyes. The bright eyes have a fierce expression, which makes the fish appear very much like a snake. These fish are ravenous, and devour crabs, snails, worms, and fishes, and if they have no other food, bite off the tails of their brethren. They are caught in eel baskets or cages, and by means of hooks; but they are rather dangerous to handle, as they attack the fishermen and injure them severely.

Since the times of the ancients, Murænæ have been prized very highly on account of their savory flesh. The Romans were great experts at feeding these fish, Vidius Pollio being the master of them all, as he made a practice of feeding his Murænæ with the flesh of slaves sentenced to death. Pliny states that at Cæsar's triumphal entry Hirius furnished six thousand Murænæ. Slaves were frequently driven into the ponds, and were immediately attacked by the voracious fishes, and killed in a very short time.

METAMORPHOSES OF ARCTIC INSECTS.

In the chapter entitled "Das insektenleben in arktischen ländern," which Dr. Christopher Aurivillius contributes to the account of A.E. Nordenskiöld's Arctic investigations, published this year in Leipzig,⁸ the author says: "The question of the mode of life of insects and of its relation to their environment in the extreme north is one of especial interest. Knowing, as we do, that any insect in the extreme north has at the most not more than from four to six weeks in each year for its development, we wonder how certain species can pass through their metamorphosis in so short a period. R. McLachlan adverts, in his work upon the insects of Grinnell Land, to the difficulties which the shortness of the summer appears to put in the way of the development of the insects, and expresses the belief that the metamorphosis which we are accustomed here to see passed through in one summer there requires several summers. The correctness of this supposition has been completely shown by the interesting observations which G. Sandberg has made upon species of lepidoptera in South Varanger, at 69° 40' north latitude. Sandberg succeeded in following the development from the egg onward of some species of the extreme north. *Oeneis bore*, Schn., a purely Arctic butterfly, may be taken as an example. This species has never been found outside of Arctic regions, and even there occurs only in places of purely Arctic stamp. It flies from the middle of June onward, and lays its eggs on different species of grass. The eggs hatch the same summer; the larva hibernates under ground, continues eating and growing the next summer, and does not even then reach its full development, but winters a second time and pupates the following spring. The pupa, which in closely related forms, in regions further to the south, is suspended free in the air upon a blade of grass or like object, is in this case made in the ground, which must be a very advantageous habit in so raw a climate. The imago leaves the pupa after from five or six weeks, an uncommonly long period for a

butterfly. In more southern regions the butterfly pupa rests not more than fourteen days in summer. The entire development, then, takes place much more slowly than it does in regions further south. Sandberg has shown, then, by this and other observations, that the Arctic summer, even at 70° N., is not sufficient for the development of many butterflies, but that they make use of two or more summers for it. If then more than one summer is requisite for the metamorphosis of the butterflies, it appears to me still more likely that the humble-bees need more than one summer for their metamorphosis. With us only the developed female lives over from one year to the next; in spring she builds the new nest, lays eggs, and rears the larvæ which develop into the workers, who immediately begin to help in the support of the family; finally, toward autumn, males and females are developed. It seems scarcely credible that all this can take place each summer in the same way in Grinnell Land, at 82° N., especially as the access to food must be more limited than it is with us. The development of the humble-bee colony must surely be quite different there. If it is not surely proved that the humble-bees occur at so high latitudes, one would not, with a knowledge of their mode of life, be inclined to believe that they could live under such conditions. They seem, however, to have one advantage over their relatives in the south. In the Arctic regions none of those parasites are found which in other regions lessen their numbers, such as the *conopidæ* among the flies, the mutillas among the hymenoptera, and others."—*Psyche*.

[8]

Nordenskiöld, A.E., Studien und forschungen veranlasst durch meine reisen im hohen norden. Autorisirte ausgabe. Leipzig, Brockhaus, 1885, 9 + 581 pp., 8 pl., maps, O. il.

A YEAR'S SCIENTIFIC PROGRESS IN NERVOUS AND MENTAL DISEASES.⁹

By L.A. MERRIAM, M.D., Omaha, Neb.,

Professor of the Principles and Practice of Medicine in the University of Nebraska College of Medicine, Lincoln, Neb.

The records of the Nebraska State Medical Society show that the only report of progress on nervous and mental diseases ever made in the history of the society (sixteen years) was made by the writer last year; and expecting that those appointed to make a report this year would, judging by the history of the past, fail to prepare such a report, I have seen fit to prepare a brief volunteer report of such items of progress as have come to my notice during the last twelve months. I have not been able to learn that any original work has been done in our State during the past year, nor that those having charge of the insane hospital have utilized the material at their command to add to the sum of our knowledge of mental diseases.

Last year I said: "There is a growing sentiment that many diseases not heretofore regarded as nervous (and perhaps all diseases) are of nervous origin." This truth, that all pathologico-histological changes in the tissues of the body are degenerative in character, and, whether caused by a parasite, a poison, or some unknown influence, are first brought about by or through a changed innervation, is one that is being accepted very largely by the best men in the profession, and the accumulation of facts is increasing rapidly, and the acceptance of this great truth will prove to be little short of revolutionary in its influence on the treatment of the disease. This is the outgrowth of the study of disease from the standpoint of the evolution hypothesis. Derangements of function precede abnormalities of structure; hence the innervation must be at fault before the organ fails. Hence the art of healing should aim at grappling with the neuroses first, for the local trophic changes, perverted secretions, and structural abnormalities are the effects or symptoms, not the causes of the disease. Dr. J.L. Thudicum has studied the chemical constitution of the brain, and he holds that, "When the normal composition of the brain shall be known to the uttermost item, then pathology can begin its search for abnormal compounds or derangements of quantities." The great diseases of the brain and spine, such as general paralysis, acute and chronic mania, and others, the author believes will all be shown to be connected with special chemical changes in neuroplasm, and that a knowledge of the composition and properties of this tissue and of its constituents will materially aid in devising modes of radical treatment in cases in which, at present, only tentative symptomatic measures are taken.

The whole drift of recent brain inquiry sets toward the notion that the brain always acts as a whole, and that no part of it can be discharging without altering the tensions of all the other parts; for an identical feeling cannot recur, for it would have to recur in an unmodified brain, which is an impossibility, since the structure of the

brain itself is continually growing different under the pressure of experience.

Insanity is a disease of the most highly differentiated parts of the nervous system, in which the psychical functions, as thought, feeling, and volition, are seriously impaired, revealing itself in a series of mental phenomena. Institutions for the insane were at first founded for public relief, and not to benefit the insane; but this idea has changed in the past, and there is a growing feeling that a natural and domestic abode, adapted to the varying severity of the different degrees of insanity, should be the place for the insane, with some reference to their wants and necessities, and that many patients (not all) could be better treated in a domestic or segregate asylum than in the prison-like structures that so often exist, and that the asylum should be as much house-like and home-like in character as the nature of the insanity would permit; while exercise and feeding are accounted as among the best remedies in some cases of insanity, particularly in acute mania.

The new disease called morbus Thomsenii, of which I wrote in my report last year, has been carefully studied by several men of eminence, and the following conclusions have been reached as to its pathology: The weight of the evidence seems to prove that it is of a neuropathic rather than a myopathic nature, and that it depends on an exaggerated activity of the nervous apparatus which produces muscular tone, and that it has much analogy to the muscular phenomena of hysterical hypnosis, the genesis of which is precisely explained by a functional hyperactivity of the nervous centers of muscular activity. Until quite recently it was supposed that the rhythmical action of the heart was entirely due to the periodical and orderly discharge of motor nerve force in the nerve ganglia which are scattered through the organ; but recent physiological observations, more especially the brilliant researches of Graskell, seem to show that the influence of the cardiac ganglia is not indispensable, and that the muscular fiber itself, in some of the lower animals, at all events possesses the power of rhythmical contraction.

Several valuable additions to our knowledge of the anatomy of the nervous system have been made by Huschke, Exner, Fuchs, and Tuzek.

Tuzek and Fuchs have confirmed the discoveries of Exner, that there are no medullated nerve fibers in the convolutions of the infant, and Flechzig has developed this law, that "medullated nerve fibers appear first in the region of the pyramidal tracts and corona radiata, and extend from them to the convolutions and periphery of the brain," being practically completed about the eighth year. This fact is of practical importance in nervous and mental diseases, since it is becoming an admitted truth that the histological changes in disease follow in an inverse order the developmental processes taking place in the embryo. Hence the recent physiological division of the nervous system by Dr. Hughlings Jackson into highest, middle, and lowest centers, and the evolution of the cerebro-spinal functions from the most automatic to the least automatic, from the most simple to the most complex, from the most organized to the least organized. In the recognition of this division we have the promise of a steadier and more scientific advance, both in the physiology and in the pathology of the nervous system.

Mr. Victor Horsley has recently demonstrated the existence of true sensory nerves supplying the nerve trunks of *nervi-nervorum*.

Prof. Hamilton, of Aberdeen, claims that the corpus callosum is not a commissure, but the decussation of cortical fibers on their way down to enter the internal and external capsules of the opposite side.

Profs. Burt G. Wilder, of Ithaca, and T. Jefrie Parker, of New Zealand Institute, have proposed a new nomenclature for macroscopic encephalic anatomy, which, while seemingly imperfect in many respects, has, at least, the merit of stimulating thought, and has given an impulse to a reform which will not cease until something has been actually accomplished in this direction. The object being to substitute for many of the polynomial terms, technical and vernacular, now in use, technical names which are brief and consist of a single word. This has already been adopted by several neurologists, of whom we may mention Spitzka, Ramsey, Wright, and H.T. Osborn.

Luys holds that the brain, as a whole, changes its position in the cranial cavity according to different attitudes of the body, the free spaces on the upper side being occupied by cerebro-spinal fluid, which, obeying the laws of gravity, is displaced by the heavier brain substance in different positions of the body.

Luys claims that momentary vertigo, often produced by changing from a horizontal to a vertical position, seasickness, pain in movement in cases of meningitis, epileptic attacks at night, etc., may be by this explained. These views of Luys are accepted as true, but to a less extent than taught by Luys. The prevalent idea that a lesion of one hemisphere produces a paralysis upon the opposite side of the body alone is no longer tenable, for each hemisphere is connected with both sides of the body by motor tracts, the larger of the motor tracts decussating and the smaller not

decussating in the medulla. Hence a lesion of one hemisphere produces paralysis upon the opposite side of the body. It has recently been established that a lesion of one hemisphere in the visual area produces, not blindness in the opposite eye, as was formerly supposed, but a certain degree of blindness in both eyes, that in the opposite eye being greater in extent than that in the eye of the same side. Analogy would indicate that other sensations follow the same law, hence the probability is that all the sensations from one side of the body do not pass to the parietal cortex of the opposite side, but that, while the majority so pass, a portion go up to the cortex of the same side from which they come.

Dr. Hammond says that the chief feature of the new Siberian disease called miryachit is, that the victims are obliged to mimic and execute movements that they see in others, and which motions they are ordered to execute.

Dr. Beard, in June, 1880, observed the same condition when traveling among the Maine hunters, near Moosehead Lake. These men are called jumpers, or jumping Frenchmen. Those subject to it start when any sudden noise reaches the ears. It appears to be due to the fact that motor impulse is excited by perceptions without the necessary concurrence of the volition of the individual to cause the discharge, and are analogous to epileptiform paroxysms due to reflex action.

The term spiritualism has come to signify more than has usually been ascribed to it, for some recent authors are now using the term to denote a neurosis or nervous affection peculiar to that class of people who claim to be able to commune with the spirits of the dead.

Evidence obtained from clinical observations has tended of late to locate the pathological lesions of chorea in the cerebral cortex.

Dr. Godlee's operation of removing a tumor from the brain marks an important step in cerebral localization, and cerebral surgery bids fair to take a prominent place in the treatment of mental diseases.

Wernicke has observed that the size of the occipital lobes is in proportion to the size of the optic tracts, and that the occipital lobes are the centers of vision.

Hughlings Jackson has observed that limited and general convulsions were often produced by disease in the cortex of the so-called motor convolutions. The sense of smell has been localized by Munk in the gyri hippocampi, while the center of hearing has been demonstrated to be in the temporal lobes. The center for the muscles of the face and tongue is in the inferior part of the central convolution; that for the arm, in the central part; that for the leg, in the superior part of the same convolution; the center for the muscles and for general sensibility, in the angular gyrus; and the center for the muscles of the trunk, in the frontal lobes. In pure motor aphasia the lesion is in the posterior part of the left third frontal convolution; in cases of pure sensory aphasia, the lesion is in the left first temporal convolution.

The relation of the cerebrum to cutaneous diseases has been studied much of late, and it is now held that the cutaneous eruptions are mainly due to the degree of inhibiting effect exerted upon the vaso-motor center.

The relation of the spinal cord to skin eruptions has been more thoroughly investigated and more abundant evidence supplied to demonstrate the influence degeneration of the spinal cord has in causing skin diseases, notably zoster, urticaria, and eczema.

This rheumatism, pneumonia, diabetes, and some kidney diseases and liver affections are often the result of persistent nervous disturbance is now held. That a high temperature (the highest recorded) has resulted from injuries of the spinal cord, and where the influence of microzymes is excluded, is not a matter of question. In one instance, the temperature reached 122° F., and remained for seven weeks between 108° and 118° F. The patient was a lady; the result was recovery. Hence it cannot be fever which kills or produces rapid softening of the heart and other organs in fatal cases of typhoid. Fever, so far as it consists in elevation of temperature, can be a simple neurosis.

Many other items of progress might be presented did time permit, particularly in the treatment of nervous affections, but this I leave for another occasion.

[9]

Volunteer report presented to Nebraska State Medical Society, May, 1885, at Grand Island, Neb.

SCARING THE BABY OUT.

Dr. Grangier, surgeon in the French army, writes from Algeria: "A few days after the occupation of Brizerte, when the military authorities had forbidden, under the severest penalties, the discharge of firearms within the town, the whole garrison was awakened at three o'clock one morning by the tremendous explosion of a heavily loaded gun in the neighborhood of the ramparts; a guard of soldiers rushed into the house from whence the sound had come, and found a woman lying on the floor with a newly born babe between her thighs. The father of the child stood over his wife with the smoking musket still in his hand, but his intentions in firing the gun had been wholly medical, and not hostile to the French troops. The husband discovered that his wife had been in labor for thirty-six hours. Labor was slow and the contractions weak and far apart. He had thought it advisable to provoke speedy contraction, and, following the Algerian custom to *scare the baby* out, he had fired the musket near his wife's ear; instantaneously the accouchement was terminated. After being imprisoned twenty-four hours, the Arab was released."—*Cincinnati Lancet*.

"ELASTIC LIMIT" IN METAL.

The *Engineering and Mining Journal* raises the question whether steel, which is becoming so popular a substitute for wrought iron, will, when it is subjected to continuous strain in suspension bridges and other similar structures, do as well as iron has proved that it can. Recent tests of sections from the cables at Fairmount Park, Philadelphia, and at Niagara Falls show that long use has not materially changed the structure. The *Journal* says: "It is a serious question, and one which time only can completely answer, whether steel structures will prove as uniformly and permanently reliable as wrought iron has proved itself to be. In other words, whether the fibrous texture of wrought iron can be equaled in this respect by the granulated texture of steel or ingot iron. In this connection it is interesting to note that the fibrous texture referred to is imparted to wrought iron by the presence in it of a small proportion of slag from the puddling furnace, and that this can be secured in the Bessemer converter also if desired. The so-called *Klein-Bessemer*, carried on at Avesta in Sweden for several years past, produces an exclusively soft, fibrous iron by the simple device of pouring slag and iron together into the ingot mould. This requires however a very small charge (usually not more than half a ton), and a direct pouring from the converter, without the intervention of a ladle, which would chill the slag."

The effect of the introduction of slag would seem to be to retrace the steps usually taken in producing steel, viz., to separate the iron from its impurities, and then to add definite quantities of carbon and such other ingredients as are found to neutralize the effects of certain impurities not fully removed.

The most intelligent engineers, after ascertaining by exhaustive physical tests what they need, present their "requirements" to the iron and steel makers, whose practical experience and science guide them in the protracted metallurgical experiments necessary to find the exact process required. The engineer verifies the product by further tests, and by practical use may find that his "requirement" needs further modifications. As a result of all this care, some degree of certainty is secured as to what the material may be expected to do.

No doubt the chemical composition of the slag used at Avesta was known and met some equally well known want in the iron, and thus the result arrived at was one which had been definitely and intelligently sought.

An important factor in selecting material for the cables of suspension bridges is its *true elastic limit*. By this term we mean the percentage of the total strength of the material which it can exert continuously without losing its resilience, i.e., its power to resume its former shape and position when stress is removed. Now, in the case particularly of steel wire as commonly furnished in spiral coils, the curve put into the wire in the process of manufacture seriously diminishes this available sustaining power.

For it is evident that it would be unsafe to subject these cables at any time to a stress beyond their elastic limit. If, e.g., a snowstorm or a great crowd of people should load a bridge beyond this limit, when the extra weight was removed the cables could not bring the bridge back to its normal place, and the result would be a permanent flattening and weakening of the arch.

By a process invented and patented by Col. Paine, the wire in the New York and Brooklyn bridge was furnished *straight* instead of curved. Now, if a short piece of common steel wire is taken from the coil, and pulled toward a straight position, and then released, it springs back into its former curve; but if a short piece of the straight-furnished wire that was put into this bridge is bent, and then released, it springs back toward its straight position.

It is easy to see that if a curved wire is pulled straight, there must occur a distention of the particles on the inside of the curve and a compression of those on the outside. The inside is in fact strained past its elastic limit before *any* stress comes upon the outside. Hence, after the wire has been pulled straight, the elastic limit of only a portion of it can be taken into the account in calculating the load that can safely be put upon it. In the case of curved steel wire pulled straight, its ultimate strength was found to be only about 90 per cent. that of similar wire furnished straight by this process. The superior ductility of iron wire in some measure compensates for the distention of the particles on the inside of the curve, and that is a reason why it has heretofore been used for suspension bridges. But with straight steel wire there is no such distention, and its *entire elastic limit* is available. This elastic limit is 66 per cent. of the ultimate strength, and, besides, that ultimate strength is 10 per cent. greater than that of similar curved wire. Thus if we have a curved steel wire large enough to sustain 1,000 lb. without breaking, a similar straight wire, such as those in this bridge, will hold up 1,100 lb., and 66 per cent. of this 1,100 lb = 720 lb.

The elastic limit of curved wire has never been determined, since any stress that will cause it to reach a straight line is beyond the elastic limit of the inside of its sectional area. That of curved iron wire has been estimated at 40 per cent. of its ultimate strength, which is about half the ultimate strength of curved steel wire; that is, it would be unsafe to put more than 40 per cent. of 500 lb.—or 200 lb.—upon a curved iron wire when a *straight* steel one can sustain 720 lb. without injury. In the New York and Brooklyn bridge the cost of a sufficient amount of such iron wire as is used in all other suspension bridges would have been some \$200,000 greater than that of the straight steel wire which was used. At five per cent., this effects an annual saving in interest of \$10,000.

There must, too, be a considerable saving in the current expense for painting and care, to say nothing of the more neat and elegant appearance of the less bulky steel. And as the whole area of the section of these wires is subjected to an even strain that is always far within the elastic limit, there is no danger of a change of structure under that stress.

It is highly probable—although Col. Paine has been too busy to work up the matter—that piano wire made in this straight method could be drawn up to and kept at pitch, without approaching very near the elastic limit. In that case not only would they seldom if ever require tuning, but probably all along the tone would be more satisfactory. And there would not be those exasperating periods when the pitch is not quite perfect, but yet is not far enough out to make it seem worth while to send for a tuner.

A catalogue, containing brief notices of many important scientific papers heretofore published in the SUPPLEMENT, may be had gratis at this office.

THE SCIENTIFIC AMERICAN SUPPLEMENT.

PUBLISHED WEEKLY.

Terms of Subscription, \$5 a Year.

Sent by mail, postage prepaid, to subscribers in any part of the United States or Canada. Six dollars a year, sent, prepaid, to any foreign country.

All the back numbers of THE SUPPLEMENT, from the commencement, January 1, 1876, can be had. Price, 10 cents each.

All the back volumes of THE SUPPLEMENT can likewise be supplied. Two volumes are issued yearly. Price of each volume, \$2.50, stitched in paper, or \$3.50, bound in stiff covers.

COMBINED RATES—One copy of SCIENTIFIC AMERICAN and one copy of SCIENTIFIC AMERICAN SUPPLEMENT, one year, postpaid, \$7.00.

A liberal discount to booksellers, news agents, and canvassers.

MUNN & CO., Publishers,

361 Broadway, New York, N.Y.

PATENTS.

In connection with the **Scientific American**, Messrs. MUNN & Co. are Solicitors of

American and Foreign Patents, have had 40 years' experience, and now have the largest establishment in the world. Patents are obtained on the best terms.

A special notice is made in the **Scientific American** of all Inventions patented through this Agency, with the name and residence of the Patentee. By the immense circulation thus given, public attention is directed to the merits of the new patent, and sales or introduction often easily effected.

Any person who has made a new discovery or invention can ascertain, free of charge, whether a patent can probably be obtained, by writing to MUNN & Co.

We also send free our Hand Book about the Patent Laws, Patents, Caveats, Trade Marks, their costs, and how procured. Address

MUNN & CO., 361 Broadway, New York.

Branch Office, cor. F and 7th Sts., Washington, D.C.

*** END OF THE PROJECT GUTENBERG EBOOK SCIENTIFIC AMERICAN
SUPPLEMENT, NO. 520, DECEMBER 19, 1885 ***

Updated editions will replace the previous one—the old editions will be renamed.

Creating the works from print editions not protected by U.S. copyright law means that no one owns a United States copyright in these works, so the Foundation (and you!) can copy and distribute it in the United States without permission and without paying copyright royalties. Special rules, set forth in the General Terms of Use part of this license, apply to copying and distributing Project Gutenberg™ electronic works to protect the PROJECT GUTENBERG™ concept and trademark. Project Gutenberg is a registered trademark, and may not be used if you charge for an eBook, except by following the terms of the trademark license, including paying royalties for use of the Project Gutenberg trademark. If you do not charge anything for copies of this eBook, complying with the trademark license is very easy. You may use this eBook for nearly any purpose such as creation of derivative works, reports, performances and research. Project Gutenberg eBooks may be modified and printed and given away—you may do practically ANYTHING in the United States with eBooks not protected by U.S. copyright law. Redistribution is subject to the trademark license, especially commercial redistribution.

START: FULL LICENSE
THE FULL PROJECT GUTENBERG LICENSE
PLEASE READ THIS BEFORE YOU DISTRIBUTE OR USE THIS WORK

To protect the Project Gutenberg™ mission of promoting the free distribution of electronic works, by using or distributing this work (or any other work associated in any way with the phrase “Project Gutenberg”), you agree to comply with all the terms of the Full Project Gutenberg™ License available with this file or online at www.gutenberg.org/license.

Section 1. General Terms of Use and Redistributing Project Gutenberg™ electronic works

1.A. By reading or using any part of this Project Gutenberg™ electronic work, you indicate that you have read, understand, agree to and accept all the terms of this license and intellectual property (trademark/copyright) agreement. If you do not agree to abide by all the terms of this agreement, you must cease using and return or destroy all copies of Project Gutenberg™ electronic works in your possession. If you paid a fee for obtaining a copy of or access to a Project Gutenberg™ electronic work and you do not agree to be bound by the terms of this agreement, you may obtain a refund from the person or entity to whom you paid the fee as set forth in paragraph 1.E.8.

1.B. “Project Gutenberg” is a registered trademark. It may only be used on or associated in any way with an electronic work by people who agree to be bound by the terms of this agreement. There are a few things that you can do with most Project Gutenberg™ electronic works even without complying with the full terms of this agreement. See paragraph 1.C below. There are a lot of things you can do with Project Gutenberg™ electronic works if you follow the terms of this agreement and help preserve free future access to Project Gutenberg™ electronic works. See paragraph 1.E below.

1.C. The Project Gutenberg Literary Archive Foundation (“the Foundation” or

PGLAF), owns a compilation copyright in the collection of Project Gutenberg™ electronic works. Nearly all the individual works in the collection are in the public domain in the United States. If an individual work is unprotected by copyright law in the United States and you are located in the United States, we do not claim a right to prevent you from copying, distributing, performing, displaying or creating derivative works based on the work as long as all references to Project Gutenberg are removed. Of course, we hope that you will support the Project Gutenberg™ mission of promoting free access to electronic works by freely sharing Project Gutenberg™ works in compliance with the terms of this agreement for keeping the Project Gutenberg™ name associated with the work. You can easily comply with the terms of this agreement by keeping this work in the same format with its attached full Project Gutenberg™ License when you share it without charge with others.

1.D. The copyright laws of the place where you are located also govern what you can do with this work. Copyright laws in most countries are in a constant state of change. If you are outside the United States, check the laws of your country in addition to the terms of this agreement before downloading, copying, displaying, performing, distributing or creating derivative works based on this work or any other Project Gutenberg™ work. The Foundation makes no representations concerning the copyright status of any work in any country other than the United States.

1.E. Unless you have removed all references to Project Gutenberg:

1.E.1. The following sentence, with active links to, or other immediate access to, the full Project Gutenberg™ License must appear prominently whenever any copy of a Project Gutenberg™ work (any work on which the phrase “Project Gutenberg” appears, or with which the phrase “Project Gutenberg” is associated) is accessed, displayed, performed, viewed, copied or distributed:

This eBook is for the use of anyone anywhere in the United States and most other parts of the world at no cost and with almost no restrictions whatsoever. You may copy it, give it away or re-use it under the terms of the Project Gutenberg License included with this eBook or online at www.gutenberg.org. If you are not located in the United States, you will have to check the laws of the country where you are located before using this eBook.

1.E.2. If an individual Project Gutenberg™ electronic work is derived from texts not protected by U.S. copyright law (does not contain a notice indicating that it is posted with permission of the copyright holder), the work can be copied and distributed to anyone in the United States without paying any fees or charges. If you are redistributing or providing access to a work with the phrase “Project Gutenberg” associated with or appearing on the work, you must comply either with the requirements of paragraphs 1.E.1 through 1.E.7 or obtain permission for the use of the work and the Project Gutenberg™ trademark as set forth in paragraphs 1.E.8 or 1.E.9.

1.E.3. If an individual Project Gutenberg™ electronic work is posted with the permission of the copyright holder, your use and distribution must comply with both paragraphs 1.E.1 through 1.E.7 and any additional terms imposed by the copyright holder. Additional terms will be linked to the Project Gutenberg™ License for all works posted with the permission of the copyright holder found at the beginning of this work.

1.E.4. Do not unlink or detach or remove the full Project Gutenberg™ License terms from this work, or any files containing a part of this work or any other work associated with Project Gutenberg™.

1.E.5. Do not copy, display, perform, distribute or redistribute this electronic work, or any part of this electronic work, without prominently displaying the sentence set forth in paragraph 1.E.1 with active links or immediate access to the full terms of the Project Gutenberg™ License.

1.E.6. You may convert to and distribute this work in any binary, compressed, marked up, nonproprietary or proprietary form, including any word processing or hypertext form. However, if you provide access to or distribute copies of a Project Gutenberg™ work in a format other than “Plain Vanilla ASCII” or other format used in the official version posted on the official Project Gutenberg™ website (www.gutenberg.org), you must, at no additional cost, fee or expense to the user, provide a copy, a means of exporting a copy, or a means of obtaining a copy upon request, of the work in its original “Plain Vanilla ASCII” or other form. Any alternate format must include the full Project Gutenberg™ License as specified in paragraph 1.E.1.

1.E.7. Do not charge a fee for access to, viewing, displaying, performing, copying or distributing any Project Gutenberg™ works unless you comply with paragraph 1.E.8 or 1.E.9.

1.E.8. You may charge a reasonable fee for copies of or providing access to or distributing Project Gutenberg™ electronic works provided that:

- You pay a royalty fee of 20% of the gross profits you derive from the use of Project Gutenberg™ works calculated using the method you already use to calculate your applicable taxes. The fee is owed to the owner of the Project Gutenberg™ trademark, but he has agreed to donate royalties under this paragraph to the Project Gutenberg Literary Archive Foundation. Royalty payments must be paid within 60 days following each date on which you prepare (or are legally required to prepare) your periodic tax returns. Royalty payments should be clearly marked as such and sent to the Project Gutenberg Literary Archive Foundation at the address specified in Section 4, "Information about donations to the Project Gutenberg Literary Archive Foundation."
- You provide a full refund of any money paid by a user who notifies you in writing (or by e-mail) within 30 days of receipt that s/he does not agree to the terms of the full Project Gutenberg™ License. You must require such a user to return or destroy all copies of the works possessed in a physical medium and discontinue all use of and all access to other copies of Project Gutenberg™ works.
- You provide, in accordance with paragraph 1.F.3, a full refund of any money paid for a work or a replacement copy, if a defect in the electronic work is discovered and reported to you within 90 days of receipt of the work.
- You comply with all other terms of this agreement for free distribution of Project Gutenberg™ works.

1.E.9. If you wish to charge a fee or distribute a Project Gutenberg™ electronic work or group of works on different terms than are set forth in this agreement, you must obtain permission in writing from the Project Gutenberg Literary Archive Foundation, the manager of the Project Gutenberg™ trademark. Contact the Foundation as set forth in Section 3 below.

1.F.

1.F.1. Project Gutenberg volunteers and employees expend considerable effort to identify, do copyright research on, transcribe and proofread works not protected by U.S. copyright law in creating the Project Gutenberg™ collection. Despite these efforts, Project Gutenberg™ electronic works, and the medium on which they may be stored, may contain "Defects," such as, but not limited to, incomplete, inaccurate or corrupt data, transcription errors, a copyright or other intellectual property infringement, a defective or damaged disk or other medium, a computer virus, or computer codes that damage or cannot be read by your equipment.

1.F.2. LIMITED WARRANTY, DISCLAIMER OF DAMAGES - Except for the "Right of Replacement or Refund" described in paragraph 1.F.3, the Project Gutenberg Literary Archive Foundation, the owner of the Project Gutenberg™ trademark, and any other party distributing a Project Gutenberg™ electronic work under this agreement, disclaim all liability to you for damages, costs and expenses, including legal fees. YOU AGREE THAT YOU HAVE NO REMEDIES FOR NEGLIGENCE, STRICT LIABILITY, BREACH OF WARRANTY OR BREACH OF CONTRACT EXCEPT THOSE PROVIDED IN PARAGRAPH 1.F.3. YOU AGREE THAT THE FOUNDATION, THE TRADEMARK OWNER, AND ANY DISTRIBUTOR UNDER THIS AGREEMENT WILL NOT BE LIABLE TO YOU FOR ACTUAL, DIRECT, INDIRECT, CONSEQUENTIAL, PUNITIVE OR INCIDENTAL DAMAGES EVEN IF YOU GIVE NOTICE OF THE POSSIBILITY OF SUCH DAMAGE.

1.F.3. LIMITED RIGHT OF REPLACEMENT OR REFUND - If you discover a defect in this electronic work within 90 days of receiving it, you can receive a refund of the money (if any) you paid for it by sending a written explanation to the person you received the work from. If you received the work on a physical medium, you must return the medium with your written explanation. The person or entity that provided you with the defective work may elect to provide a replacement copy in lieu of a refund. If you received the work electronically, the person or entity providing it to you may choose to give you a second opportunity to receive the work electronically in lieu of a refund. If the second copy is also defective, you may demand a refund in writing without further opportunities to fix the problem.

1.F.4. Except for the limited right of replacement or refund set forth in

paragraph 1.F.3, this work is provided to you 'AS-IS', WITH NO OTHER WARRANTIES OF ANY KIND, EXPRESS OR IMPLIED, INCLUDING BUT NOT LIMITED TO WARRANTIES OF MERCHANTABILITY OR FITNESS FOR ANY PURPOSE.

1.F.5. Some states do not allow disclaimers of certain implied warranties or the exclusion or limitation of certain types of damages. If any disclaimer or limitation set forth in this agreement violates the law of the state applicable to this agreement, the agreement shall be interpreted to make the maximum disclaimer or limitation permitted by the applicable state law. The invalidity or unenforceability of any provision of this agreement shall not void the remaining provisions.

1.F.6. INDEMNITY - You agree to indemnify and hold the Foundation, the trademark owner, any agent or employee of the Foundation, anyone providing copies of Project Gutenberg™ electronic works in accordance with this agreement, and any volunteers associated with the production, promotion and distribution of Project Gutenberg™ electronic works, harmless from all liability, costs and expenses, including legal fees, that arise directly or indirectly from any of the following which you do or cause to occur: (a) distribution of this or any Project Gutenberg™ work, (b) alteration, modification, or additions or deletions to any Project Gutenberg™ work, and (c) any Defect you cause.

Section 2. Information about the Mission of Project Gutenberg™

Project Gutenberg™ is synonymous with the free distribution of electronic works in formats readable by the widest variety of computers including obsolete, old, middle-aged and new computers. It exists because of the efforts of hundreds of volunteers and donations from people in all walks of life.

Volunteers and financial support to provide volunteers with the assistance they need are critical to reaching Project Gutenberg™'s goals and ensuring that the Project Gutenberg™ collection will remain freely available for generations to come. In 2001, the Project Gutenberg Literary Archive Foundation was created to provide a secure and permanent future for Project Gutenberg™ and future generations. To learn more about the Project Gutenberg Literary Archive Foundation and how your efforts and donations can help, see Sections 3 and 4 and the Foundation information page at www.gutenberg.org.

Section 3. Information about the Project Gutenberg Literary Archive Foundation

The Project Gutenberg Literary Archive Foundation is a non-profit 501(c)(3) educational corporation organized under the laws of the state of Mississippi and granted tax exempt status by the Internal Revenue Service. The Foundation's EIN or federal tax identification number is 64-6221541. Contributions to the Project Gutenberg Literary Archive Foundation are tax deductible to the full extent permitted by U.S. federal laws and your state's laws.

The Foundation's business office is located at 809 North 1500 West, Salt Lake City, UT 84116, (801) 596-1887. Email contact links and up to date contact information can be found at the Foundation's website and official page at www.gutenberg.org/contact

Section 4. Information about Donations to the Project Gutenberg Literary Archive Foundation

Project Gutenberg™ depends upon and cannot survive without widespread public support and donations to carry out its mission of increasing the number of public domain and licensed works that can be freely distributed in machine-readable form accessible by the widest array of equipment including outdated equipment. Many small donations (\$1 to \$5,000) are particularly important to maintaining tax exempt status with the IRS.

The Foundation is committed to complying with the laws regulating charities and charitable donations in all 50 states of the United States. Compliance requirements are not uniform and it takes a considerable effort, much paperwork and many fees to meet and keep up with these requirements. We do not solicit donations in locations where we have not received written confirmation of compliance. To SEND DONATIONS or determine the status of compliance for any particular state visit www.gutenberg.org/donate.

While we cannot and do not solicit contributions from states where we have not met the solicitation requirements, we know of no prohibition against accepting unsolicited donations from donors in such states who approach us with offers to

donate.

International donations are gratefully accepted, but we cannot make any statements concerning tax treatment of donations received from outside the United States. U.S. laws alone swamp our small staff.

Please check the Project Gutenberg web pages for current donation methods and addresses. Donations are accepted in a number of other ways including checks, online payments and credit card donations. To donate, please visit: www.gutenberg.org/donate

Section 5. General Information About Project Gutenberg™ electronic works

Professor Michael S. Hart was the originator of the Project Gutenberg™ concept of a library of electronic works that could be freely shared with anyone. For forty years, he produced and distributed Project Gutenberg™ eBooks with only a loose network of volunteer support.

Project Gutenberg™ eBooks are often created from several printed editions, all of which are confirmed as not protected by copyright in the U.S. unless a copyright notice is included. Thus, we do not necessarily keep eBooks in compliance with any particular paper edition.

Most people start at our website which has the main PG search facility: www.gutenberg.org.

This website includes information about Project Gutenberg™, including how to make donations to the Project Gutenberg Literary Archive Foundation, how to help produce our new eBooks, and how to subscribe to our email newsletter to hear about new eBooks.