

The Project Gutenberg eBook of The Scientific American Boy; Or, The Camp at Willow Clump Island, by A. Russell Bond

This ebook is for the use of anyone anywhere in the United States and most other parts of the world at no cost and with almost no restrictions whatsoever. You may copy it, give it away or re-use it under the terms of the Project Gutenberg License included with this ebook or online at www.gutenberg.org. If you are not located in the United States, you'll have to check the laws of the country where you are located before using this eBook.

Title: The Scientific American Boy; Or, The Camp at Willow Clump Island

Author: A. Russell Bond

Release date: May 15, 2005 [EBook #15831]
Most recently updated: March 16, 2010

Language: English

*** START OF THE PROJECT GUTENBERG EBOOK THE SCIENTIFIC AMERICAN BOY; OR, THE CAMP AT WILLOW CLUMP ISLAND ***

E-text prepared by Don Kostuch
and revised by Roger Frank, Juliet Sutherland,
and the Project Gutenberg Online Distributed Proofreading Team
(<http://www.pgdp.net>)
HTML version prepared by Roger Frank, Juliet Sutherland,
and the Project Gutenberg Online Distributed Proofreading Team

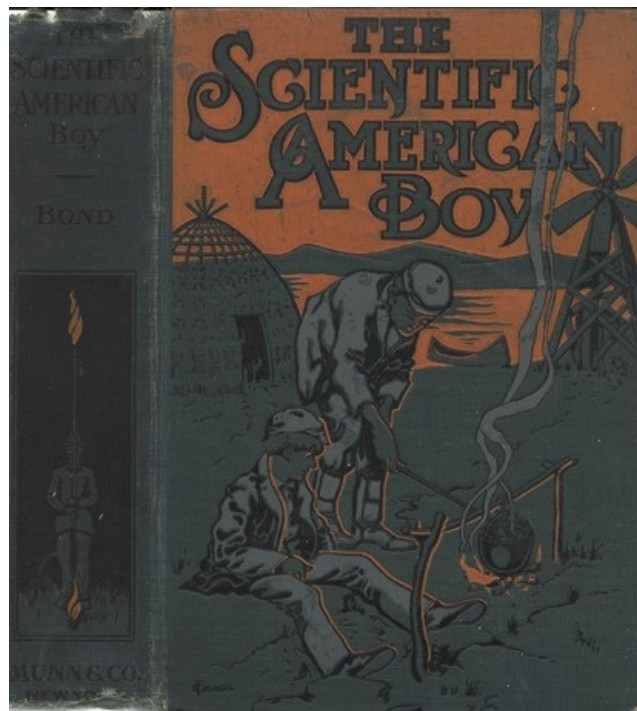

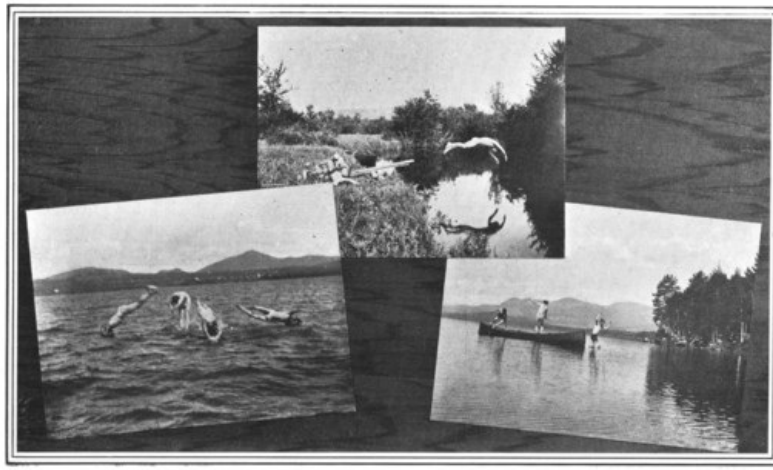

Fun in Swimming.

The SCIENTIFIC AMERICAN BOY

OR

The Camp at Willow Clump Island

By
A. RUSSELL BOND



NEW YORK

MUNN & CO., *Publishers*

1906

COPYRIGHT, 1905, BY
MUNN & CO., NEW YORK

PRESS OF
THE KALKHOFF COMPANY
NEW YORK

PREFACE



ll boys are nature lovers. Nothing appeals to them more than a summer vacation in the woods where they can escape from the restraints of civilization and live a life of freedom. Now, it may appear to be a bit of presumption to attempt to advise the boy camper how to spend his time. Surely the novelty of outdoor life, the fascinating charm of his surroundings, will provide him plenty of entertainment.

But, after all, a camp generally affords but two major amusements, hunting and fishing. These have been fully covered by a vast number of books. However, there is another side of camp life, particularly in a boys' camp, which has been very little dealt with, namely, the exercise of one's ingenuity in creating out of the limited resources at hand such devices and articles as will add to one's personal comfort and welfare. It is, therefore, the aim of this book to suggest certain diversions of this character for the boy camper which, aside from affording him plenty of physical exercise, will also develop his mental faculties, and above all stimulate that natural genius which is characteristic of every typical American boy. To this end the story contains descriptions of a

large collection of articles which can be made by any boy of average intelligence, not only in the camp but at home as well.

The use of a narrative to connect the various incidents marks a departure in this class of book, and it is believed that the matter will thus be made more realistic and interesting. In all cases full directions are given for making the various articles. While it is not presumed that the directions will be slavishly followed, for this would defeat the general aim of the work, yet all the principal dimensions are given so that they can be used, if desired.

I beg to acknowledge the courtesy of Mr. Daniel C. Beard and Mr. Henry D. Cochrane in supplying a number of photographs. The directions for making the lee boards (page 119) were obtained from data furnished by the latter. Many of the details recorded in the chapter on Tramping Outfits are to be accredited to Mr. Edward Thorpe. In the preparation of this book I have received valuable assistance from my colleague, Mr. A. A. Hopkins.

A. RUSSELL BOND.

NEW YORK, *October*, 1905.

CONTENTS

	PAGE
CHAPTER I.	
"BILL"	17
The Old Trunk. Christmas Vacation. "Bill's" Skate Sail. Willow Clump Island. Organizing the Society.	
CHAPTER II.	
SKATE SAILS	26
The Double Swedish Sail. The Single Swedish Sail. The Lanteen Sail. The Danish Sail. Bat's Wings.	
CHAPTER III.	
SNOW SHOES, SKIS AND SWAMP SHOES	35
Chair Seat Snow Shoe. Barrel Stave Snow Shoe. Barrel Hoop Snow Shoe. The Sioux Snow Shoe. The Iroquois Snow Shoe. The Ainu Snow Shoe. The Norwegian Ski. The Swamp Shoe or Swiss Snow Shoe.	
CHAPTER IV.	
TENT MAKING	44
Farewell Meeting. Word from Uncle Ed. The Canvas Tent. Adjustable Ridge Pole. Tie Blocks. The Annex.	
CHAPTER V.	
PREPARING FOR THE EXPEDITION	53
Tent Fly. Provisions and Supplies. Umbrella Rib Crossbow. Megaphone. The Scow.	
CHAPTER VI.	
OFF TO THE ISLAND	63
A Unique Alarm Clock. The Trip to the Island. Preliminary Exploration. A Rustic Table. The Small Filter. The Barrel Filter. The <i>Klepalo</i> .	
CHAPTER VII.	
SURVEYING	73
The Surveying Instrument. Spirit Levels. The Tripod. Surveyor's Chain. Surveyor's Rod. A Simple Method of Surveying. Mapping the Island.	
CHAPTER VIII.	
SWIMMING	84
Swimming on a Plank. Shooting the Rapids. Restoring the Drowned. How to Work over a Patient Alone.	
CHAPTER IX.	
BRIDGE BUILDING	95
The Spar Bridge. The Rope Railway. The Suspension Bridge. The Pontoon Bridge. The King Rod Truss. Stiffening the Bridge. The King Post Bridge.	
CHAPTER X.	
CANVAS CANOES	109

Uncle Ed's Departure. A Visit from Mr. Schreiner. The Sailing Canoe. Stretching on the Canvas. The Rudder. The Deep Keel. Canoe Sails. Lee Boards. Indian Paddling Canoe.

CHAPTER XI.

HOUSE BUILDING 124

The Grass Hut. The Goblins' Dancing Platform. Dutchy Takes a Dare. A Path Up the Fissure. Rope Ladders. The Derrick. The Tree House. Sliding Doors.

CHAPTER XII.

TROUBLE WITH THE TRAMPS 138

The Scow is Stolen. A Council of War. Vengeance. A Double Surprise. Tramp-proof Boat Mooring.

CHAPTER XIII.

WIGWAGGING AND HELIOGRAPHING 144

Wigwag Signals. The Wigwag Alphabet. Abbreviations. Wigwagging at Night. The Heliograph. The Single Mirror Instrument. The Sight Rod. The Screen. Focusing the Instrument. Heliograph Signaling. The International Telegraph Code. The Double Mirror Instrument.

CHAPTER XIV.

ICE BOATS, SLEDGES AND TOBOGGANS 158

Breaking Camp. The Ice Boat. The Sledge. The Toboggan. The Rennwolf. Ice Creepers.

CHAPTER XV.

THE SUBTERRANEAN CLUB 171

A Cave-in. Excavating for the Cave. Covering the Cave. The Big Bug Club. Midnight Banquets. The Club Pin. The Combination Lock.

CHAPTER XVI.

SCOOTERS 183

A Sail in the Scow. Our Craft Strikes the Ice. The Scooter Scow. A Sprit Sail. Scooter Sailing. A Meeting of the Society. An Interview with Mr. Van Syckel. The Scooter Canoe.

CHAPTER XVII.

AN ARCTIC EXPEDITION 193

Willow Clump Island in Winter. Kindling a Camp Fire. The Outdoor Fireplace. A Stone-paved Fireplace. A Cold Night in the Hut. Mountain Climbing. A Poor Shelter. A Costly Camp Fire. A Friend in Time of Trouble.

CHAPTER XVIII.

TRAMPING OUTFITS 203

Sleeping Bags. Bill's "Mummy Case." The "A" Tent. A Camp Chair. A Camp Bed. The Camp Bed in a Shower. A Nightmare. Pack Harness. Riveting.

CHAPTER XIX.

THE LAND YACHT 215

The Frame of the Yacht. A Simple Turnbuckle. Stepping the Mast. Mounting the Frame on Bicycle Wheels. The Tiller. A "Leg-of-Mutton" Sail. A Sail Through the Country.

CHAPTER XX.

EASTER VACATION 224

Bill's Cave. The Barrel Stave Hammock. The Barrel Armchair. The Summer Toboggan. Tailless Kites. A Five-foot Malay Kite. An Eight-foot Malay Kite. The Elastic Belly Band. Putting the Kites to Work. The Diamond Box Kite.

CHAPTER XXI.

THE WATER WHEEL 240

The Water Wheel. Surveying for the Water Wheel. Towers for the Water Wheel. The Wheel. The Buckets. The Paddles. The Receiving Trough. Setting Up the Towers. Mounting the Water Wheel. Cooling the Filter Barrel. The Canvas Bucket. Mr. Halliday's Water Wheel.

CHAPTER XXII.

THE LOG CABIN 254

Foundation of Log Cabin. A Logging Expedition. The Log Raft. The Sail-Rigged Raft. Building the Log Cabin. The Roof of the Log Cabin. Door and Window Frames. The Fireplace. The Proper Way to Build a Stone Wall. The Floor of the Cabin. The Door Hinges and Latch. The Window Sash. Bunks. Stopping up the Chinks.

Digging the Well. The Windmill Tower. The Crank Shaft. The Wind Wheel. A Simple Brake. The Pump. Pump Valves. Action of the Pump.

The Car. The Flanged Wheels. Car Axles. Mounting the Wheels. The Railway Track. The Carpenter's Miter Box. Laying the Track. The First Railway Accident. Testing the Track.

Frames for the Cantilever Bridge. Erecting the Towers. Setting up the Frames. Binding and Anchoring the Structure. The Center Panels of the Bridge. A Serious Interruption. Dispossessed. Farewell to Willow Clump Island. Reddy's Cantilever Bridge.

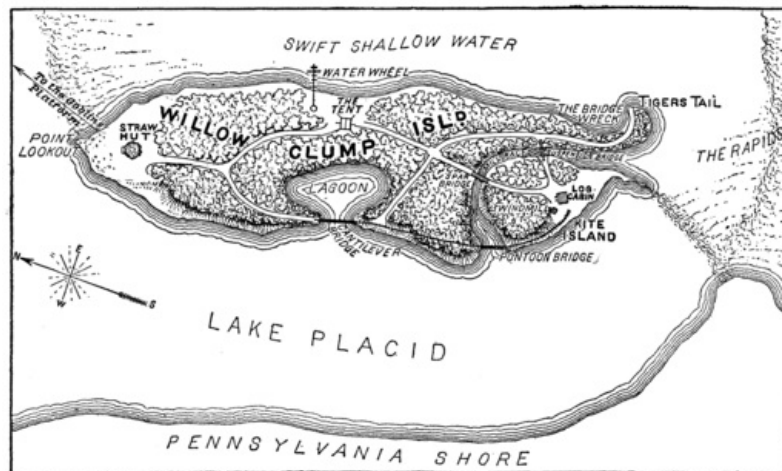

Map of Willow Clump Island and Vicinity.

THE SCIENTIFIC AMERICAN BOY.

CHAPTER I.

"BILL."

"Bill," he was it, the Scientific American Boy, I mean. Of course, we were all American boys and pretty scientific chaps too, if I do say it myself, but Bill, well he was the whole show. What he didn't know wasn't worth knowing, so we all thought, and even to this day I sometimes wonder how he managed to contrive and execute so many remarkable plans. At the same time he was not a conceited sort of a chap and didn't seem to realize that he was head and shoulders above the rest of us in ingenuity. But, of course, we didn't all have an uncle like Bill did. Bill's Uncle Ed was one of those rare men who take a great interest in boys and their affairs, a man who took time to answer every question put to him, explaining everything completely and yet so clearly that you caught on at once. Uncle Ed (we all called him that) was a civil engineer of very high standing in his profession, which had taken him pretty much all over the world, and his naturally inquisitive nature, coupled with a wonderful memory, had made him a veritable walking encyclopedia. With such an uncle it is no wonder that Bill knew everything. Of course, there were some things that puzzled even Bill. But all such difficulties, after a reasonable amount of brain-work had failed to clear them, were submitted to Uncle Ed. Uncle Ed was always prompt (that was one thing we liked about him), and no matter where he was or what he was doing he would drop everything to answer a letter from the society.

The Old Trunk.

But hold on, I am getting ahead of my story. I was rummaging through the attic the other day, and came across an old battered trunk, one that I used when I went to boarding-school down in



Fig. 1. The Old Trunk in the Attic.

For hours I pored over those pages, carried back to the good old times we used to have as boys along the banks of the Delaware River, until I was brought sharply back to the present by the sound of the dinner bell. It seemed that the matter contained in those "Chronicles" was too good to be kept locked up in an old trunk. Few boys' clubs ever had such a president as Bill, or such a wonderful bureau of information as Uncle Ed. For the benefit of boys and boykind in general, I decided then and there to publish, as fully as practicable, a record of what our society did.

south Jersey. That trunk was certainly a curiosity shop. It contained a miscellaneous assortment of glass tubes, brass rods, coils of wire, tools, fish hooks—in fact, it was a typical collection of all those "valuables" that a boy is liable to pick up. Down in one corner of the trunk was a black walnut box, marked, with brass letters, "Property of the S. S. I. E. E. of W. C. I." On my key-ring I still carried the key to that box, which had not been opened for years. I unlocked the box and brought to light the "Records and Chronicles of the Society for the Scientific Investigation, Exploration and Exploitation of Willow Clump



Fig. 2. The Black Walnut Box.

Christmas Vacation.

This was how the society came to be formed. Bill, whom I met at boarding-school, was an orphan, and that's why he was sent to boarding-school. His uncle had to go down to Brazil to lay out a railroad, I believe, and so he packed Bill off to our school, which was chosen in preference to some others because one of the professors there had been a classmate of Uncle Ed's at college. Bill roomed with me, and naturally we became great chums. When Christmas time came, of course I invited him to spend the holidays with me. My home was situated in the little village of Lamington, on the Jersey side of the Delaware River. Here we arrived late at night on the Saturday before Christmas. A cold wind was blowing which gave promise of breaking the spell of warm weather we had been having, and of giving us a chance to try our skates for the first time. True to our expectations, the next day was bitterly cold, and a visit to the canal which ran along the river bank, just beyond our back fence, showed that quite a thick skim of ice had formed on the water. Monday morning, bright and early, found us on the smooth, slippery surface of the canal. "Us" here includes, in addition to Bill and myself, my two younger brothers, Jack and Fred, and also Dutchy Van Syckel and Reddy Schreiner, neighbors of ours. It was the custom at the first of December every year to drain out most of the water in the canal, in order to prevent possible injury to the canal banks from the pressure of the ice. But there was always a foot or two of water covering the bottom of the canal, and this afforded a fine skating park of ample width and unlimited length, while the high canal banks on each side protected us from the bitter wind that was blowing. Toward noon, however, the wind shifted and swept at a terrific rate down the narrow lane between the canal banks. We could scarcely make headway against the blow. It was too much for Bill, who wasn't as used to skating as we were. He sat down in a sheltered nook and commenced to think. When Bill sat down to think it always meant that something was going to happen, as we soon learned.

"Say, Jim," said he to me, "have you got any canvas up at the house?"

"No," I replied. "What do you want it for?"

"I want to rig up a skate sail. If you have an old sheet, that will do just as well."

"Well, I guess I can find you an old sheet. Do you think you can make one?"

"Sure thing," answered Bill, and off we went to the house, where I received my first lesson on the practical genius of my chum.

"Bill's" Skate Sail.

The old sheet which Mother furnished us was laid out on the floor and two corners were folded over to the center, as shown in the drawing, making a triangle with base 7 feet long and sides each about 4 feet 6 inches long. The surplus end piece was then cut off, and a broad hem turned and basted all around the edges of the triangle. Bill wanted to work the sewing machine himself, but Mother was afraid he would break something, so she sewed down the hem for us. Then, under Bill's supervision, she re-enforced the corners by sewing on patches of cloth. Along the diagonal a strip of heavy tape was sewed, leaving loops at intervals, which afterward were cut and provided means for tying the sail to the mast. Tie strings of tape were also sewed at the corners, as shown in the illustration, and then a trip was made to the garden in search of suitable spars. A smooth bean pole of about the right weight served for the mast, and another stick with a crotch at one end served as the boom or cross-spar. The spars were cut to proper length, and the sail was then tied on, as illustrated, with the crotch of the cross-spar fitted against and tied to the center of the mast. A light rope, long

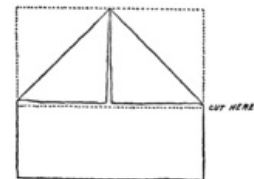

Fig. 3. Laying Out the Sail.



Fig. 4. The Tape Tie Strings.

enough to provide plenty of slack, was tied to the ends of the mast to assist in guiding the sail when in use. In the meantime I had procured another sheet from one of our neighbors, and Bill helped me make a sail for myself. It was not until long after dark that we finished our work.

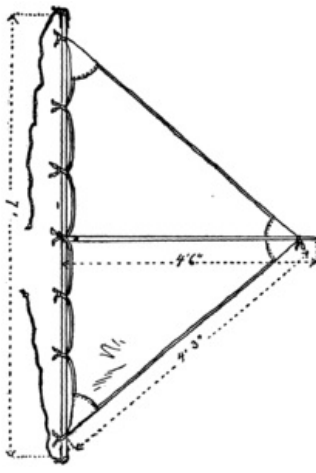

Fig. 5. "Bill's" Sail Complete.

Willow Clump Island.

The next day we tried the sails and it didn't take me very long to learn how to steer the device. The wind had changed again and this time blew up the canal. We took the line of least resistance, and went skimming up the ice lane like birds for several miles before we realized how far we were getting away from home. As we rounded a bend in the canal, much to my astonishment, I saw just before us the bridge at Raven Hill, eight miles from our town. We started to go back, but the wind was too strong for us, and there wasn't much room in which to do any tacking; nor could we make any progress when the sails were folded. I began to get extremely tired and rather exasperated at Bill for not having thought of the return trip before he led me such a hot pace up the canal. But Bill was getting tired, too.

"Look here, Jim," he said, "we haven't covered a mile, and I'm worn out."

"Why in thunder didn't you think of this before we started?" I returned.

"How much money have you with you?" was the reply.

"What's that got to do with it?"

"I'll tell you in a minute. How much have you?"

A careful search of my dozen odd pockets netted the sum of twenty-seven cents.

"I have fifty-nine," said Bill, "and that makes eighty-six altogether, doesn't it? Isn't there a railroad depot near here?"

"There is one at Raven Hill, and the next is at Lumberville. That is about eleven miles from home."

"Well," said Bill, "at three cents each per mile that would amount to sixty-six cents. Let's sail on to Lumberville and then take the train back."

On we sped to Lumberville, only to find that the next train was not due until noon, and it was now just half past ten.

Time never hung heavy on our hands. Out on the river we espied an island. I had heard of this island—Willow Clump Island, it was called—but had never been on it; consequently I fell in with Bill's suggestion that we make it a visit. Owing to the rapids which separated the island from the Jersey shore, we had to go up stream a quarter of a mile, to where a smooth sheet of ice had formed, over a quiet part of the river; thence we sailed down to the island along the Pennsylvania side.

"What a capital island for a camp," cried Bill, after we had explored it pretty thoroughly. "Have you ever been out camping?"

I had to confess I never had, and then Bill gave me a glowing account of his experiences in the Adirondacks with his uncle the year before, which so stirred up the romance in me that I wanted to camp out at once.

"Shucks!" said Bill, "We would freeze in this kind of weather, and besides, we've got to make a tent first."

We then sat down and made elaborate plans for the summer. Suddenly the distant sound of a locomotive whistle interrupted our reveries.

"Jiminy crickets!" I exclaimed. "That's the train coming through Spalding's Cut. We've got to hustle if we are to catch it."

We were off like the wind, and a merry chase brought us to the Lumberville depot in time to flag the train. We arrived at Lamington at half past twelve, a trifle late for dinner, rather tired and hungry, but with a glowing and I fear somewhat exaggerated account of our adventure for the credulous ears of the rest of the boys.

Organizing the Society.

The camping idea met with the hearty approval of all, and it was decided to begin preparations at

once for the following summer. Dutchy, whose father was a member of a geographical society, suggested that we form a society for the exploration of Willow Clump Island. By general acclamation Bill was chosen president of the society, Dutchy was made vice-president, Reddy was elected treasurer, and they made me secretary. It was Dutchy who proposed the name "The Society for the Scientific Investigation, Exploration and Exploitation of Willow Clump Island." It was decided to make an expedition of exploration as soon as we could make skate sails for the whole society.

CHAPTER II. SKATE SAILS.

26

The duties of the secretary, as defined in the constitution which Dutchy Van Syckel drew up, were to keep a record of all the acts of the society, the minutes of every meeting, and accurate detailed descriptions of all work accomplished. Therefore, while the rest of the society was busy cutting up old sheets, levied from the surrounding neighborhood, and sewing and rigging the sails under Bill's direction, I, with pad and pencil in hand, took notes on all the operations.

The Double Swedish Sail.

Bill evolved some new types of sails which differed materially from the type described in the first chapter. One was a double sail—"the kind they use in Sweden," he explained. One of the sheets which the foraging party brought in was extra large; it measured approximately two yards and a half square. This was folded on itself, making a parallelogram seven feet six inches long and three feet nine inches wide. The sheets we had were all rather worn and some were badly torn, so that we had to make our sails of double thickness, sewing patches over the weak spots. A broad hem was turned down at each end, and heavy tape was sewed on, leaving loops as before, to attach them to the spars. This reduced the length of our sail to seven feet three inches. The end spars were spaced apart by a light pole about ten feet long, to which they were tied at the points of

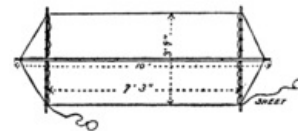

27

Fig. 6. Dimensions of Double Swedish Sail.
N. B.—The mark (') means feet and (") means inches.



Fig. 7. Halyards Looped onto Pole.

intersection. The spars were also braced by halyards looped over the ends of the pole in the manner indicated in the drawing (Fig. 7). It took a crew of two boys to manipulate this sail. In use, the pole of the rig was carried on the shoulders, and the sail was guided by means of ropes attached to the lower corners of the vertical spars. These ropes in nautical language are called "sheets." The boy at the rear was the pilot and did the steering, because his position behind the sail gave him an unobstructed view in all directions. When changing tack the sail was lifted overhead to the other side of the crew.

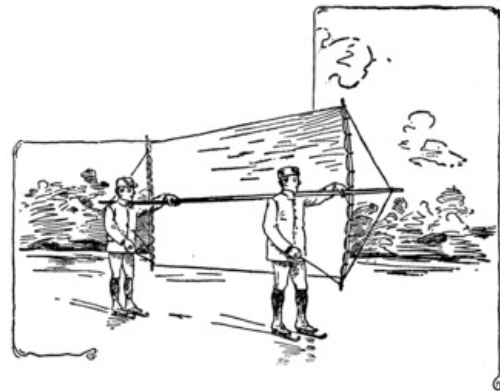

28

Fig. 8. The Double Swedish Sail.

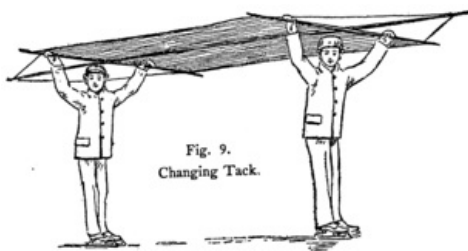
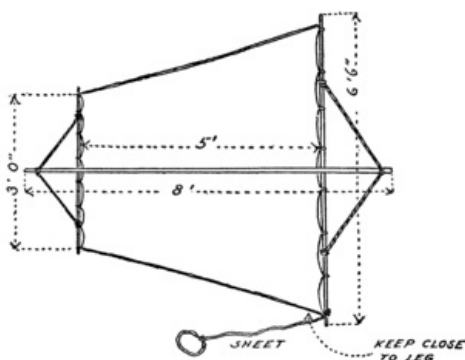

Fig. 9. Changing Tack.

The Single Swedish Sail.

Another sail of similar form, but for use of one boy only, is shown in Fig. 10. This had a height of six and one-half feet at the forward end and three feet at the rear; and its length was five feet. This sail was very satisfactory in light winds, owing to its great area. In use we found that it was very important to keep the lower edge against the leg, as indicated by the arrow. The rig was manipulated just like the double Swedish sail, lifting it over the head when it was desired to change tack.

29



The Lanteen Sail.

The lanteen sail we found to be a very good rig. It was made in the form of a triangle, measuring eight feet on one side, seven and one-half feet on another side and six and one-half feet on the third. The six and one-half foot side was secured to a boom, and the seven and one-half foot side to a yard. The yard and boom were hinged together by a leather strap nailed on as shown in Fig. 12, and to this hinge a rope was attached, which served as a sheet. These spars were secured to a mast erected perpendicularly to the boom and intersecting the yard a little above its center. We had had some trouble with the first sails we made in keeping the base of the sail against the body, and to overcome this difficulty Bill proposed tying

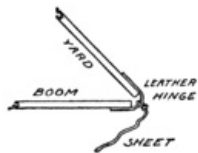

Fig. 12. Hinge for Spars.

the bottom of the mast to the leg. This was a rather risky thing to do, as we learned later, for in case of accident it would be difficult to get clear of the sail. It was Reddy who finally solved the problem by rigging up a step for the mast. It consisted of a leather tag tied to the leg, and provided with a hole into which the bottom of the mast was fitted. To prevent the mast from slipping too far into the step the lower portion of it was whittled down, leaving a shoulder which rested on the leather. Bill later devised another step, which consisted of a wooden block (Fig. 14) strapped to the leg and formed with a shallow socket to receive the end of the mast.



Fig. 14. Wooden Mast Step.

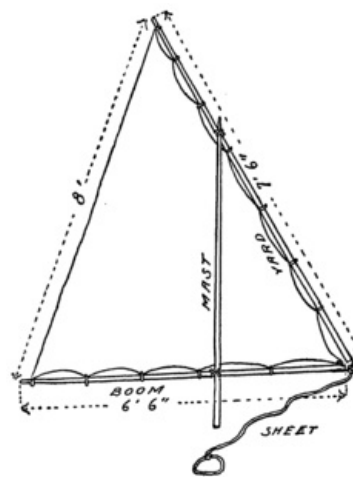

Fig. 11. The Lanteen Sail.



Fig. 13. Leather Mast Step.

The Danish Sail.

But the most satisfactory sail we found to be the Danish sail, though it was not until we had served quite a long apprenticeship and sustained many pretty bad falls that we mastered the art of manipulating these sails properly. Our ideas on this sail were obtained from a French illustrated paper which Dutchy Van Syckel picked up in his father's library. This sail was formed with a topsail so arranged that it could be lowered when the wind was too strong. The dimensions of the sail as we made it are given in the drawing (Fig. 15). The top of the sail was lashed to a spar, which was connected by a short stick to another spar tied to the mainsail about eighteen inches lower down. The sail was strengthened with an extra strip of cloth along the lower spar, and the tie strings were applied in the usual way. The connecting stick, or topmast we may call it, was hinged to the lower spar by means of a short piece of leather strap, which was passed round the spar in the form of a loop and its two ends nailed to the bottom of the topmast. The topmast extended above the upper spar a short distance, and to this we fastened the flag which our society had adopted. A couple of strong cords were secured to the center spar to provide for fastening the sail onto the skater. Tied to the lower corners of the mainsail were two sticks which were used for guiding the sail when in flight.

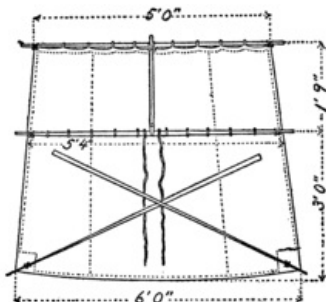

Fig. 15. The Danish Sail.



Fig. 16. Topsail of the Danish Rig.

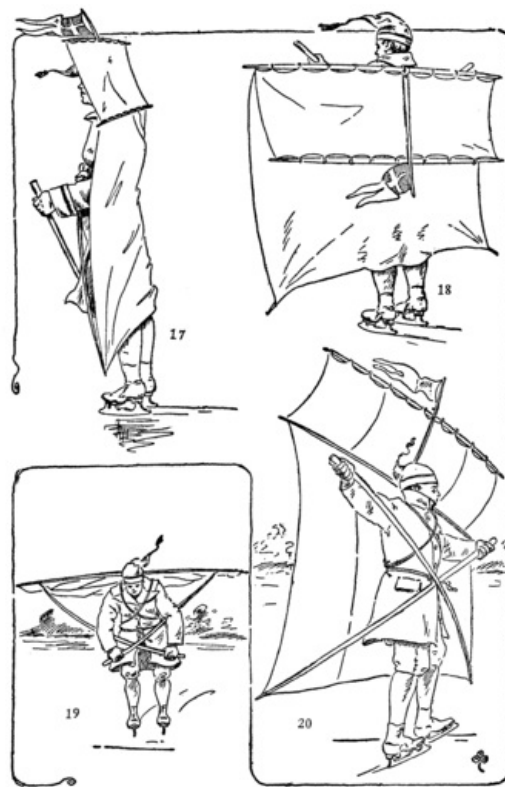

Fig. 17. Before the Wind. Fig. 18. Topsail Lowered. Fig. 19. Skating against the Wind. Fig. 20. On the Port Tack.

The different methods of sailing with this rig are shown in Figs. 17-20. When sailing with the wind the skater would stand very erect, bending backward in proportion as the wind blew fresher. By inclining the sail in one direction or the other, the skater could tack to port or starboard. When moving against the wind by skating in the usual way, the body was bent forward in such manner that the sail lay horizontal, so that it would not offer a purchase for the wind.

33

Bat's Wings.

One more sail deserves mention. It was Bill's idea, and it came near to ending his career the first day he tried it. It had no spars at all, but was merely a strip of cloth of somewhat triangular shape. The upper side was tied to the head, and the two corners to the wrists, while the lower corners were tied to the ankles. This converted him into a huge white-winged bat. Bill had to try it at once, even though the rest of the sails were not finished, and a very comical spectacle he made as he flapped his wings in his endeavors to tack. When the wind was too strong for him he had merely to drop his arms and thus lower sail.

34



Fig. 21.

At length he became tired of holding his arms out at full length, and I got him a stick to put over his shoulders and rest his arms on. But that stick was Bill's undoing, for coming around a sudden bend in the canal he caught the full force of the wind, which knocked him flat on his back before he could disentangle himself from the stick and lower sail. It took us some time to bring him back to consciousness, and a very scared lot of boys we were for a while. However, the lesson was a good one, for after that we were very cautious in experimenting with sails that had to be tied on, such as the Danish rig and the lanteen rig, before Reddy invented the mast step.

It was not until the day after Christmas that the sails were all completed, but then there was scarcely any wind blowing and we could not attempt the expedition to the island.

CHAPTER III.

SNOW SHOES, SKIS AND SWAMP SHOES.

35

The next day, Sunday, it began to snow, and we realized that our chance of skating up to Willow Clump Island was spoiled. All the afternoon it snowed, and the next morning we woke to find the ground covered to a depth of eight inches and snow still falling. But who ever heard of a boy complaining because there was snow on the ground? Here were new difficulties to overcome, new problems to solve, and new sports provided for our amusement. There was no disappointment shown by any of the members of the S. S. I. E. E. of W. C. I., as they met in the

woodshed immediately after breakfast to discuss proceedings for the day. There seemed to be but one way of reaching the island, and that was by means of snow shoes. Bill had only a vague idea of how snow shoes were made.

Chair Seat Snow Shoe.



Fig. 22. Chair Seat Snow Shoe

The first pair was made from a couple of thin wooden chair seats which we found in the shed. They proved quite serviceable, being very light and offering a fairly large bearing surface. The chair seats were trimmed off at each side to make the shoes less clumsy, and a loop of leather was fastened near the center of each shoe, in which the toe could be slipped. This shoe possessed the disadvantage of being too flat and of picking up too much snow when used.

36

Barrel Stave Snow Shoe.

Another pair of shoes was made from barrel staves. At first one stave was made to serve for a shoe, but we found that two staves fastened together with a pair of wooden cleats were much better. Jack was the proud inventor of these shoes and insisted that they were far more satisfactory than the elaborate ones which were later devised.



Fig. 23. Barrel Stave Snow Shoe.

Barrel Hoop Snow Shoe.



Fig. 24. Barrel Hoop Snow Shoe.

Now that Jack had shown his ingenuity, Fred thought it was his turn to do something, and after mysteriously disappearing for the space of an hour we saw him suddenly come waddling back to the shed on a pair of barrel hoops covered with heavy canvas. He had stretched the canvas so tightly across the hoops that they were bent to an oval shape. It was claimed for these shoes, and with good reason, that they were not so slippery as the barrel stave shoe, for they permitted the foot to sink slightly into the snow.

37

After dinner, Dutchy came back with a book of his father's, a sort of an encyclopedia in which several different kinds of snow shoes were illustrated. Reddy, whose father owned a sawmill, volunteered to provide us with strips of hickory from which to make the frames.

The Sioux Snow Shoe.

The Sioux snow shoe was the first type we tackled. Two strips of hickory 4 feet long and 3/4 inch square in section, were bent over a pair of spreaders and securely fastened together at each end. The spreaders were about 12 inches long and located about 15 inches apart. They were notched at the ends, as shown in Fig. 26, to receive the side strips, which were not fastened together until after they had been nailed to the spreaders. We found that the most satisfactory way of fastening together the ends of the hickory strips was to bolt them together. When the

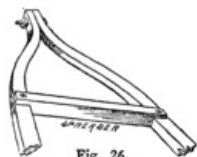

Fig. 26. Frame of the Sioux Shoe.

frame was completed, we began the tedious process of weaving in the filling or web of the snow shoe. First we cut notches in the edges of the spreaders, spacing these notches an inch apart. Then we procured several balls of heavy twine at the corner store. Tying one end of the cord to the right side stick about three inches below the forward spreader, we stretched a strand down to the notch at the left end of the lower spreader. The strand was drawn taut, and after making several

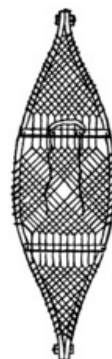

Fig. 25. Sioux Shoe.

38

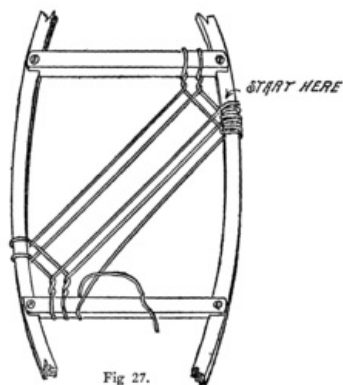

Fig 27. Web of the Sioux Shoe.

twists around it the cord was tied to the left side stick three inches above the spreader. From this point the cord was stretched to the notch at the right end of the upper spreader, twisted several times and brought back to the starting point. The cord was now wrapped around the side stick for a space of about an inch, and then carried down to the second notch on the lower spreader, whence it was woven through the other two strands and tied about the left side stick about four inches from the spreader. Thus the weaving continued, passing the cord alternately over and under any cross strands encountered. In order to make the left side correspond with the right, a separate cord was wound around it, filling up the space between the strands of the web. The filling above and below the spreaders could not be so methodically done, but we managed to weave the strands quite neatly with about the same mesh as used at the center. To facilitate the weaving we improvised a rough needle of a piece of



Fig. 28. Weaving Needle

39

The Iroquois Shoe.

But the best snow shoe we made was the Iroquois shoe. The frame of this shoe was made of hickory strips of the same width and thickness as used in the Sioux shoe, but 8 feet long. The strips were bent in a loop and the ends were bolted together. How to bend the wood without breaking it seemed a very difficult problem. Wood, we knew, could be easily bent without breaking if boiled or steamed for a while; but we had nothing large enough in which to boil a strip of wood 8 feet long. Bill hit upon the plan of wrapping the stick with burlap and then pouring boiling water on it until it became sufficiently soft to bend easily. An old oats-sack was cut up into strips and wound onto the hickory sticks for a distance of 18 inches at each side of the center. We then repaired to the kitchen to do the steaming. The hickory stick was held over a large dish-pan filled with boiling water, and from this we dipped out the water and poured it slowly over the burlap wrapping of the stick. After a little of this treatment the stick was sufficiently steamed to permit of bending to the required shape. The ends were then firmly secured by means of bolts passed through bolt holes which had been previously drilled. The frame was completed by fitting the spreader sticks in place, after which it was laid away to dry. When the frame was perfectly dry we started weaving the web. In this case, however, instead of cord we used cane strips, which we had bought from a chair caner. This necessitated drilling holes in the side sticks to receive the cane strips. The web consisted of strands crossing each other diagonally, as illustrated. Our second pair of Iroquois snow shoes was made with a web of rawhide which we bought from a hardware store at Millville.



Fig. 29. Bending the Hickory Strips.



Fig. 30. Frame of Iroquois Shoe.

however, instead of cord we used cane strips, which we had bought from a chair caner. This necessitated drilling holes in the side sticks to receive the cane strips. The web consisted of strands crossing each other diagonally, as illustrated. Our second pair of Iroquois snow shoes was made with a web of rawhide which we bought from a hardware store at Millville.



Fig. 31. Iroquois Snow Shoe.

The Ainu Snow Shoe.

One of the snowshoes described in the book was very much like Fred's barrel-hoop snow shoe in appearance. According to the description, it was a type used by the Ainus, a peculiar people living in the cold northern islands of Japan. As the shoe seemed quite simple and rather unique, we thought we would make one like it. Two hickory strips each 4 feet long were bent to a U-shape and lashed together, forming an oval about 2 feet 6 inches long by 18 inches wide. The frame was held to oval shape by tying the sides together. Then the filling was woven in, running the strands diagonally, as shown in Fig. 32.

We had excellent weather for snow shoes after that snowstorm. A thaw followed by a cold spell caused a thick crust to form on the snow which would nearly hold us up without the aid of our snowshoes. We were rather awkward with those shoes for a while, trying to keep them clear of each other, and we found it particularly hard to turn sharply without causing one shoe to run foul of the other. But with a little practice we soon felt quite at home on them. In order to prevent cutting the web with our heels, we found it necessary to wear rubbers.



Fig. 32. Ainu Snow Shoe.

Our vacation came to an end before we were prepared for the expedition to Willow Clump Island. But before leaving the subject on snow shoes, two more shoes remain to be described, namely the Swiss snow shoe and the Norwegian ski. The Swiss shoe was made during the summer and the ski during the following winter.



Fig. 33. The Norwegian Ski.

The Norwegian Ski.

The Norwegian ski was made of close-grained wood, 1 inch thick, 3-1/2 inches wide and 6 feet long. About 18 inches from the forward end the wood was planed down to a thickness of 1/4 of an inch. This end was placed in the dish-pan of boiling water, and in a short time it was pliable enough to permit of bending. It was secured in the proper bent position by slipping the toe end of the shoe between the banisters on the back porch and nailing a cleat back of the heel end. When the ski was perfectly dry the toe strap was nailed on just back of the balancing point, and also another strap, to be secured about the ankle. Then a cleat was nailed onto the ski to fit against the heel of the shoe. In use we found it best to cut a groove in the bottom of the ski, so as to give us a better grip on the snow in climbing up hills. With the skis we had to use short poles or "ski sticks" to assist in starting, stopping and steering when coasting. The ski stick was a bean pole provided with a wooden block near the lower end, to prevent it from being forced too far through the snow.



Fig. 34. Bending the Ski.



Fig. 35. The Ski Stick.

The Swiss Snow Shoe or Swamp Shoe.

The Swiss shoe was made primarily to assist us in exploring some boggy land a short distance up the river from our island. The original swamp shoes were made from the bottoms of two old baskets, and they worked so admirably that it was decided to equip the whole society with them. Uncle Ed, when told about them, informed us that that was the kind of snow shoe used in Switzerland. Of course, we could not afford to destroy a pair of baskets for each member of the club, and so we had to weave the shoes from the willows which grew on the island.



Fig. 36. The Swiss Snow Shoe.

CHAPTER IV. TENT MAKING.

44

We had a farewell meeting of the society the evening before Bill and I had to return to boarding-school. At this meeting plans were made for the Easter vacation. We also considered the matter of getting parental permission for our summer outing. So far we had been afraid to breathe a word of our plans outside of the society, since Fred had said something about it in the presence of Father and had been peremptorily ordered to banish all such hair-brained, Wild West notions from his head. We realized from that incident that the consent of our parents would not be so very easily obtained. But Bill came forward with a promising suggestion. He would write to his Uncle Ed and see if he couldn't be persuaded to join the expedition. At first we demurred. We didn't want a "governor" around all the time. But Bill assured us that his uncle was "no ordinary man"; that he would not interfere with our plans, but would enter right into them and give us many valuable pointers. Though not by any means convinced, we told him to go ahead and invite his uncle, as that seemed about the only means of winning over our fathers and mothers. The society was then adjourned until our Easter vacation began, each member promising to earn and save as much money as he could in the meantime to buy the materials for a tent and provisions for the summer outing.

45

Word From Uncle Ed.

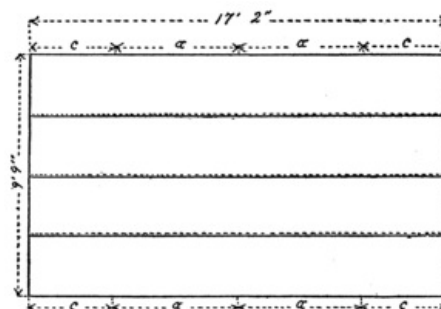

Fig. 37. Breadths sewed together for Roof and Side Walls of Tent.

Bill's letter to Uncle Ed was answered as quickly as the mail could travel to Brazil and back. Uncle Ed heartily approved of our plans, and said that he would be delighted to join the expedition. He could not be on hand before the 1st of July, but that would give us plenty of time to make all necessary preparations. He told us not to worry about gaining the consent of our parents. He would write to them and see them all personally, if necessary to win their approval.

The Canvas Tent.

When at last spring arrived and we returned to Lamington on our Easter vacation, quite a sum of

46

money had been collected, nearly \$15.00, if I remember rightly; at any rate plenty to buy the materials for a good-sized tent and leave a large surplus for provisions, etc. Bill figured out on paper just how much canvas we would need for a tent 7 feet wide by 9-1/2 feet long, which he estimated would be about large enough to hold us. It took 34 yards, 30 inches wide. Then we visited the village store to make our purchase. Canvas we found a little too expensive for us, but a material called drill seemed about right. It cost ten cents a yard, but since we wanted such a quantity of it the price was reduced to a total of \$3.00. We repaired to the attic to lay out the material.

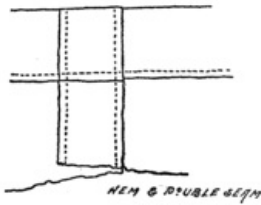

Fig. 38. The Sail Stitch.

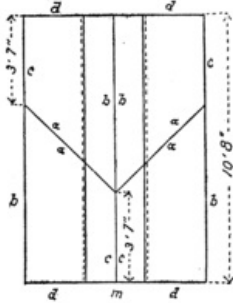

Fig. 39. Cutting out the Door Flaps.

the door flaps we started first at the bottom of the side *c*, sewing it to the side edge of the main piece, as shown in Fig. 40, and running the seam up for a distance of exactly 3 feet 6 inches. After all the door strips had been sewed along their *c* edges the sewing was continued up the diagonal or *a* edges. In cutting out the door pieces we had allowed 1 inch on each side for hems and seams, so that the door pieces met without lapping at the exact center of the main or body piece, that is, at the peak of the tent.

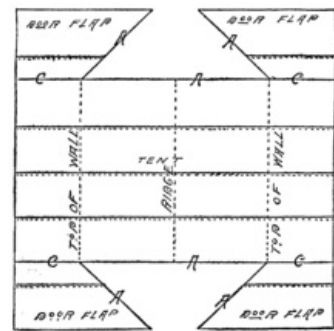

Fig. 40. Sewing on the Door Flaps.



The Wall Tent Set Up in the Back Yard.

Our next step was to fasten the necessary ropes and loops. Ten 8-foot lengths of light rope were procured. These were fastened at the top of the side walls, that is, 3 feet 6 inches from the ends of the main or body piece, one at each corner and one on each seam. The cloth was strengthened at these points with patches sewed on the inside. At the bottom of the side walls we sewed on loops of heavy tape. These were spaced about 15 inches apart. Along the *b* edges of the door pieces tie strings of tape were fastened. A rope 15 feet long was attached to the peak at the front and at the rear of the tent. The front and rear posts of the tent were made from scantlings measuring 2 by 4 inches, which were procured from Mr. Schreiner's lumber yard. They were planed smooth and sawed off to a length of 7 feet 6 inches. A slot was cut in the end of each stick to

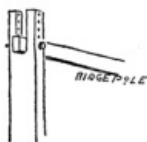

Fig. 41. Adjustable Ridge Pole.

a depth of 6 inches and measuring slightly over an inch in width. For the ridge pole a strip 1 inch thick, 2-1/2 inches wide and 10 feet long was secured. This was fitted into the slotted ends of these posts, where it was fastened by wooden pegs slipped into holes drilled through the ends of the posts and the ridge pole. A number of these peg holes were provided, so that if the canvas stretched the ridge pole could be raised or lowered to prevent the walls from dragging on the ground. We set up the tent in our back yard to see if it was properly constructed. Twelve stakes were required, ten for the sides and one for the ridge stays at the front

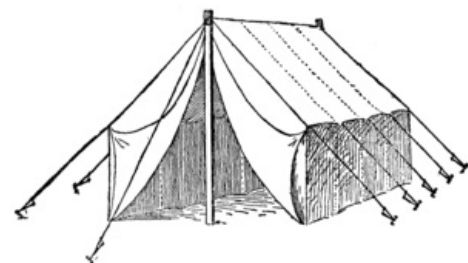

Fig. 42. The Tent Set Up.

and rear. The side stakes were driven into the ground at a distance of about 8 feet from the center of the tent. First we tied the guy ropes to the stakes, but later we found it much easier to secure them with tie blocks.

Tie Blocks.



Fig. 43. The Wood Tie Block.

These were made of wood 1/2 inch thick, 1 inch wide and each measured 3 inches long. A hole was drilled into the block at each end and through these holes the rope was threaded. A knot in the rope then held the end from slipping out. The loop between the two holes, or the bight, as sailors would call it, was now slipped over the stake, and the rope hauled tight by drawing up the tie block, as shown in Fig. 43. A still later improvement consisted in making ties of stout galvanized iron wire, bent to the form shown in Fig. 44. The wooden ties were apt to swell and split open when exposed to the weather, while the wire ties could always be relied upon.



Fig. 44. The Wire Tie.



Fig. 45. Bottom of Tent Wall.

The walls of the tent were held down along the bottom by railway spikes hooked through the tent loops and driven into the ground. Wooden pegs with notches to catch the loops would have served as well, but Dutchy happened to find a number of the spikes along the track and in his usual convincing manner argued that they were far better than pegs because their weight would hold the cloth down even if they were not firmly embedded in the ground.

The Annex.

We were surprised to find out how small the tent was after it was set up. We could see at once that when we had put in all the stores and provisions we would need, there would not be room enough for six boys and a man to stretch themselves out comfortably in it. Bill had evidently made a miscalculation, but he suggested that we remedy the error by building an annex for our kitchen utensils and supplies.

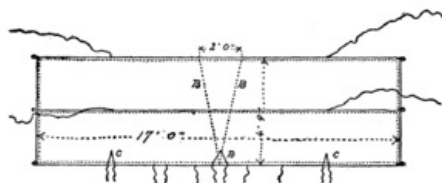

Fig. 46. Cutting out the Annex.

This gave us a two-room tent, which we found to be quite an advantage. Twelve more yards of drill were bought and cut into two strips, each 17 feet 2 inches long. The breadths were then sewed together, and the ends turned up and hemmed to make a piece 17 feet long and 4 feet 9 inches wide. Tape loops were then sewed on as before, and ropes were fastened on at the top of the side walls, that is, 3 feet 6 inches from the ends of the strips. We thought it would be better to have a slanting ridge on the annex, so we cut out a wedge-shaped piece from the center of the two strips, as shown by dotted lines *B B* in Fig. 46. This wedge-shaped piece measured 2 feet at the outer end of the annex, and tapered down to a point at the inner end. The canvas was then sewed together along these edges. Tie strings were sewed to the inner edge of the annex and corresponding ones were attached to the main tent a little ways back from the edge, so that the two could be tied together, with the annex lapping well over on the roof and side walls. A notch was cut out of the peak of the annex, so that it could be tied around the rear post of the tent, and notches were cut at the top of the side walls to permit passing the cloth around the wall ropes. Instead of supporting the ridge of the annex on a ridge pole, we used the rear guy line of the tent, propping it up with a scantling about 5-1/2 feet long.

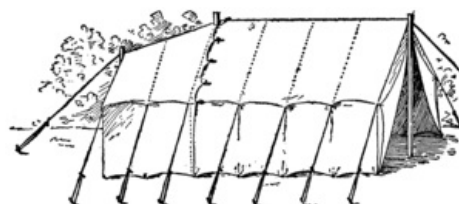

Fig. 47. The Annex Applied.

CHAPTER V.

PREPARING FOR THE EXPEDITION.

School closed on the 21st of June that year, just ten days before the expected arrival of Uncle Ed. The first thing we did was to set up our tent in the back yard and camp out so as to become acclimatized. It is good that we did this, for the very first night a heavy summer shower came up which nearly drenched us. The water beat right through the thin canvas roof of our tent. Had we been able to afford the best quality of canvas duck, such an occurrence would probably have been avoided. But we solved the difficulty by using a tent fly; that is, a strip of canvas stretched over the tent and spaced a short distance from it to break the fall of the rain drops.



Fig. 48. The Wall Tent with the Fly fastened on.

Tent Fly.

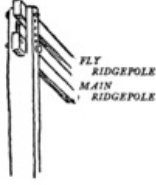

Fig. 49. The Fly Ridge Pole.

Again we had to visit the village storekeeper; this time we bought out his whole remaining stock, sixteen yards of drill. This was cut into four-yard strips, which were sewed together as before and the ends turned up and hemmed. Tie strings were sewed to the ends of the strips so that the fly could be tied to the wall ropes of the tent. At the ridge the fly was supported about six inches above the tent rope by a second ridge pole held by pegs in the top holes of the tent posts.

54

Provisions and Supplies.

The ten days before Uncle Ed arrived were busy indeed. We had to gather together the necessary provisions and supplies. Our personal outfits were very simple. Each member supplied himself with a change of underwear, a bathing suit, a blanket and a toothbrush. A single comb and brush served for the entire society, and was used on Sundays, the only day we really dressed up. All the rest of the time we lived in our bathing suits, except, of course, on cold rainy days. Our kitchen outfit consisted of a large cooking pot, two kettles, a frying pan, a coffee pot, a small oil stove, a half-dozen each of plates, cups, saucers, knives and forks, a dozen spoons, two tablespoons, and, in addition, several large plates and bowls for pantry use. We also took with us a dish-pan and several dish-towels. For our larder we collected the following: A bag of flour, ten pounds of sugar, two pounds of salt, three pounds of coffee, four pounds of oatmeal, four pounds of butter, two pounds of lard, six pound of beans, six pounds of rice, three pounds of bacon, six cans of condensed milk, a dozen eggs, box of pepper, and several jars of canned peaches and pears, and also a half dozen glasses of jelly.

55

It was Dutchy who suggested that we have a chicken yard, in connection with our camp, to supply us with fresh eggs. It was a capital idea, and by the dint of some coaxing we managed to secure the loan of a half dozen hens and a rooster.

Our miscellaneous list included a spade, pick and shovel, an ax, a hatchet, two large pails, a barn lantern, a can of kerosene, a dozen candles, a cocoa box filled with matches, a pair of scissors, needles, buttons, pins and safety pins, a spool of white and another of black cotton, fishing tackle, a roll of heavy twine, a coil of rope, and a set of dominoes and checkers. But most important of all was a chest of tools belonging to Reddy. These were all collected when Uncle Ed arrived. Dutchy also contributed a large compass, which we found very useful later on, for surveying the island.

Crossbow.

Reddy had a shotgun which he wanted to bring along, but my father, and Dutchy's as well, wouldn't let us go camping if there was to be any gunpowder along, so we had to leave it behind. Of course we didn't miss it at all when we got to the island, because there was so much else to do; but we all agreed with Dutchy, that "it wouldn't be no sort of a scientific expedition without takin' a gun along." As a substitute I suggested a bow and arrow. They all laughed at such a "kiddish" idea; all but Bill, I mean.

56



Drifting down the Schreiners' Brook.



Paddling in the Old Scow.



Fig. 50. Binding the Bow.



Fig. 51. The Trigger.

"It ain't such a bad notion," said he, "only a crossbow would be better. I've seen them made out of umbrella ribs so they'd shoot like greased lightning." Of course we had to have one of these wonderful weapons. Down in the ash heap we found two broken umbrellas with 27-inch ribs. Bill selected ten good ribs, from which he wrenched off the spreaders with a pair of pliers. The ribs were then bound together by winding stout twine around them. The winding was very evenly and closely done, so that the cord completely covered the ribs, making a solid rod of spring steel. But before winding we had laid in between the ribs a piece of heavy twine, to which the bowstrings could be tied after the bow was all wound. The stock of our crossbow was cut out of a board of soft wood 1 inch thick to as near the shape of a gun as we could get it. A hole was drilled through the muzzle end to receive the bow, and then the bowstring was tied fast. Along the upper edge of the barrel a V-shaped channel was cut. The channel was not very deep, only enough to receive a tenpenny nail with the head projecting half-way above the sides. A notch was cut across the barrel, through this channel, at the trigger end, and a trigger made of heavy iron wire, bent to the shape shown in Fig. 51, was hinged to the gun by a bolt which passed clear through the stock and through both eyes of the trigger. By using two nuts on the bolt, and tightening one against the other, they were prevented from working loose and coming off. When we wanted to fire the gun the bowstring was drawn back, and held by slipping it into the notch, and a nail was laid in the channel with its head against the bowstring. Then, on pulling the trigger, the bowstring was lifted out of the notch, and sent the nail off sailing. The long-grooved barrel insured a very good aim.

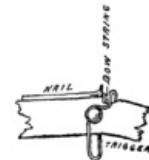

Fig. 52. The Trigger Set for Firing.



Fig. 53. The Umbrella Rib Crossbow.

Megaphone.

Another device we made in preparation for the expedition was a megaphone. A sheet of light cardboard 30 inches square was procured. At the center of one edge a pin was stuck into the

cardboard, then a piece of stout thread was looped over the pin and the two

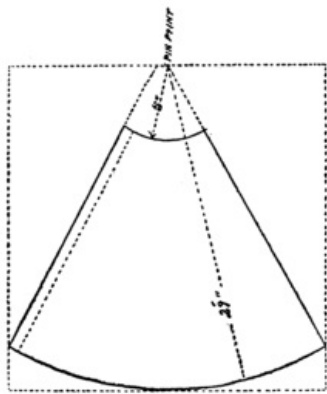

Fig. 55. Layout of the Megaphone.



Fig. 56. Brass Fastener.

A mouthpiece was formed out of a block of wood in which a large hole had been drilled. The block was then cut away until the walls were quite thin. The hole was reamed out at the top, as shown in Fig. 57, and the outer surface was tapered so that the small end of the megaphone would fit snugly on it.

We planned to reach our camping grounds by way of the canal, and had provided for that purpose a large scow, which we expected to tow up to Lumberville and drag over to the river.

The Scow.

Our scow was made as follows: Two 3/4-inch pine boards, 12 inches wide and 12 feet long, were selected from Reddy's father's lumber pile. These were used for the side pieces of the boat, and we tapered them off at the end to a width of 3-1/2 inches. This was done by making a straight cut from the end to a point three feet back along the edge of the board and then rounding off the edge with a draw-knife. When one board had been shaped, it was used as a pattern for the other, which was thus cut to exactly the same size. For the end pieces two strips, 4 inches wide and 2 feet 10-1/2 inches long, were sawed out of a 1-inch board. Then for the bottom we procured a number of 3/4-inch boards, 12 feet long and 8 inches wide, which we cut into 3-foot lengths. At Bill's suggestion, before nailing the parts together, we secured some strips of flannel, which were saturated with paint, and laid between the seams so as to make the boat perfectly water-tight. The side and end boards were then nailed together, with the strips of flannel between, the side boards overlapping the end boards, as shown in Fig. 59. After planing down the end boards until their

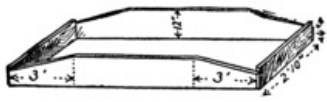

Fig. 59. Frame of the Scow.

edges laid flush with the edges of the side pieces, the bottom boards were nailed on, strips of cloth being inserted between them, as well as along the edges of the side and end boards. To brace the bottom a 3/4-inch board was placed at the center, inside the boat, and bent down against the floor, to which it was nailed with wire nails. The

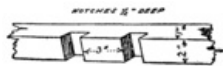

Fig. 61. Sockets for Rowlocks.



Fig. 62. Thole Pin.

nails were driven into the board from the outer side of the boat and were clinched inside. Along the upper edges of the side boards two strips 2 inches wide and 1 inch thick were nailed. Two notches were cut in the inner side of each strip before it was nailed on. The notches were 1/2 inch deep, 1-1/2 inches wide, 3 inches apart and about 5-1/2 feet from the stern end. When the strips were nailed in place these notches formed sockets to receive the rowlocks. A strip was also nailed across the stern of the boat and formed with two central notches, to receive the rowlocks for a steering oar. This strip, however, was 3 inches wide, and projected 1 inch above the end board, so as to lie flush with the deck boards, which were later applied. Six thole pins, 1/2 inch thick, 4-1/2 inches long and 2 inches wide, were cut out of an oak board. The lower end of each pin was reduced to a width of 1-1/2 inches for a length of 2 inches. The thole pins were then fitted snugly in the notches. Two cleats, nailed to the side boards inside, 7 inches below the upper edge, served to support a seat board 1 inch thick and 2 feet 10-1/2 inches long. The aft edge of the seat was about 10 inches forward of the rowlocks. The boat was completed by nailing on a couple of deck boards at each end. The oars were made of 2-inch pine boards, 5 feet long and 5 inches wide. They were blocked out at

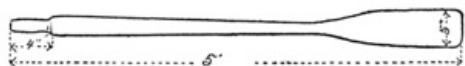

Fig. 64. The Oar.

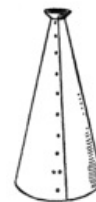

Fig. 54. The Megaphone.



Fig. 57. The Mouthpiece.



Fig. 58. Side pieces of the Scow.



Fig. 60. Nailing on the Bottom.



Fig. 63. Nailing on the Decks.

Mr. Schreiner's sawmill and then shaped and smoothed down with a draw-knife and spoke-shaved. They were 1-1/4 inches at the handle and 2 inches immediately below, tapering down to a diameter of 1-1/4 inches at the top of the blade. The blades were 18 inches long, 5

inches wide, and planed down to a thickness of 1/4 inch along the edges.

CHAPTER VI. OFF TO THE ISLAND.

The morning of July 2d dawned bright and clear, but long before daybreak the members of the S. S. I. E. E. of W. C. I. were astir. The jolly red sun peeping over the eastern hills witnessed an unaccustomed sight. Six greatly excited boys were running back and forth from the barn to the canal, bearing all manner of mysterious bundles, which were carefully deposited in a freshly painted scow. Yes, all six of us were there.

A Unique Alarm Clock.

We hadn't expected to see Reddy Schreiner at such an early hour, for he was always a sleepyhead, and no alarm clock would ever wake him. But this was an exceptional day, and, besides, Reddy was quite an original chap. He had taken one of the borrowed roosters into his room the night before, and when, early in the morning, Mr. Chanticleer had mounted the footboard of the bed, flapped his wings and given vent to his opinion of a boy who persisted in sleeping at that late hour of the day, the noise was too much for even Reddy's drowsy sensibilities.



Fig. 65. Off to the Island.

The Trip to the Island.

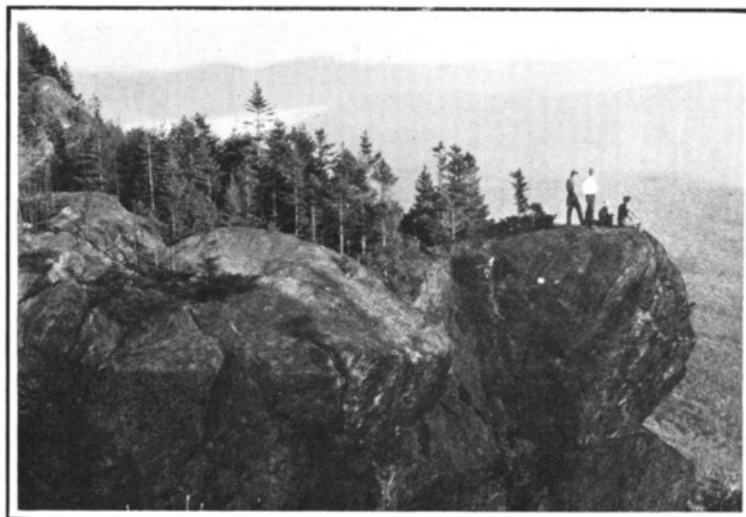

The Ledge below the Goblins' Platform.



The Camp at Willow Clump Island.

Our scow was not large enough to carry all the things we had to take with us, but as Mr. Schreiner was going to take Uncle Ed up in his wagon, we left the rest of our luggage for him to bring along. We boys walked the eleven miles up the canal to Lumberville, towing the barge. It was a tiresome task; but we divided the work into two-mile shifts, two boys towing at a time and then each taking a mile ride as steersman in the boat. It was about noon when we arrived at Lumberville, and then we had to unload our boat before we could haul it out of the canal and down to the river. The river on the Jersey side of the island was so shallow that we waded across, pushing the boat ahead of us. The current was too swift to permit of rowing, and it was rather hard for us to keep our footing. But we managed to reach our destination finally without any mishap. The island was thickly wooded, except for a small clearing where we landed. The first thing we did was to unpack our eatables, and Jack, the cook, soon had an appetizing pan of bacon and eggs sputtering on the kerosene stove.



Fig. 66. Dragging the Scow over to the Island.

Preliminary Exploration.

As no better position offered at the time we pitched our tent in the clearing, pending a thorough search for a more suitable place elsewhere. Around the tent we dug a trench about a foot deep to prevent water from entering our quarters when it rained. It was about time for Uncle Ed and Mr. Schreiner to appear with the rest of our luggage, so we did not have time to do much exploring, but sauntered southward along the shore, always on the lookout for their arrival. About a quarter of a mile from the tent we came across the wreck of an old bridge, which had been washed down by some freshet. This was a great find, and served us many purposes, as will appear later.

While we were examining the wreck we heard a distant "halloa" from the mainland. There was Uncle Ed sitting on a pile of goods on the railroad bank looking for all the world like an Italian immigrant. We answered with a shout and scrambled back to the clearing. Then we ran splashing through the water, pushing the boat before us. It didn't take us long to load up and carry him back to the island.

A Rustic Table.

Uncle Ed entered into our fun at once. He was as enthusiastic as a boy over the surroundings, and when we told him of the old bridge he started right off to investigate, taking the ax with him. Soon he had pried off a number of the planks, which we used for a flooring to our tent. Then he built us a table out of four forked sticks, driven into the ground, and supporting two cross sticks, on which a pair of planks were laid.

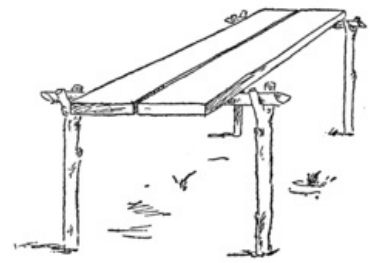

Fig. 67. The Rustic Table.

The Small Filter.

“Well, now, boys,” said Uncle Ed, wiping the perspiration from his forehead, “I am as thirsty as a whale. Where do you get your drinking water? Is there a spring on the island?”

We told him that we used the river water.

“What, river water! That won’t do at all,” he cried. “You’ll all have the typhoid fever. We must build a filter. I brought some charcoal with me for this very purpose.”



Fig. 68. The Small Filter.

Taking one of our pails he broke a hole in the bottom of it and stuffed a sponge in the hole. A layer of small stones was then placed in the pail, over this a layer of broken charcoal with the dust carefully blown out, then a layer of clean sand, and finally a layer of gravel. Each layer was about two inches thick. The pail was suspended from a branch in a cool place and proved an excellent filter, the water trickling out through the sponge being perfectly pure and sweet, no matter how dirty it had been when poured in; but the capacity of the filter was too small, and Uncle Ed said he would make us a larger one on the morrow if no spring was discovered in the meantime.

The sun was getting low in the west, and we therefore postponed the exploration of our island until the following day. We had been up since four o’clock that morning and had done some pretty hard work; so, immediately after supper, we turned in and, lulled by the murmuring of the river, were soon fast asleep.

The Barrel Filter.

Immediately after breakfast the next day we started out in two parties to search the island. The only discovery of any moment was that made by Dutchy’s party, which found a small island separated from ours by a narrow channel, through which the water ran like a mill-race. No spring was discovered, so Uncle Ed had to construct his large filter. Bill and I went over to Lumberville in search of a couple of cider barrels and a painful of charcoal. The barrels were placed one on top of the other after cutting a large hole in the top of the lower barrel, and a smaller one in the bottom of the upper one. The latter opening was covered by an inverted saucer. Over this we spread a 3-inch layer of coarse sand, then a 2-inch layer of charcoal, a 4-inch layer of clear, sharp sand, and a 2-inch top layer of gravel. The lower barrel was provided with a faucet, through which we could draw off the filtered water as desired. In order to keep the water cool we placed the filters in a shady place near the river, and piled up earth around the lower barrel.

“Now, boys,” said Uncle Ed, “form in line there, and we will go through a fire drill.”

He arranged us about five feet apart in a line extending from the filter to the river. We had six pails, and these Dutchy filled one at a time, passing them up the line to Reddy, who emptied them into the upper barrel and then threw them back to Dutchy to be refilled. Working in this way it did not take long to fill up the filter, and the burden of keeping the barrels full, instead of falling on one person, was shared alike by all.



Fig. 69. The Barrel Filter.



Fig. 70. Filling the Barrel.

The Klepalo.

Our camp outfit was further augmented by a dinner call. We discovered the necessity of such a call on our very first day of camping. Dutchy was so excited by his discoveries of the morning that he started out alone in the afternoon to make a further search. The rest of us were lazy after the noon meal, and were lolling around taking it easy during the heat of the day, and discussing plans for the future. But Dutchy's energetic nature would not permit him to keep quiet. He took the scow and waded with it against the strong current to the deeper and quieter water above the island. Then he rowed a long way up stream. He was gone all the afternoon. Supper time came and still he didn't appear. The sun was high, and I presume he didn't realize how late it was getting. Finally, just at sunset, he came drifting down with the current, tired and hungry, and ready for a large meal. But we had finished our supper an hour before, and poor Dutchy had to be content with a few cold remnants, because the cook had declared he wouldn't prepare an extra meal for a fellow who didn't have sense enough to know when it was meal time.

71

Then it was that Uncle Ed bethought himself of the *klepalo*.

"You ought to have some sort of a dinner call," he declared, "so that any one within a mile of camp will know when dinner is ready."

"Did you ever hear of a *klepalo*? No? Well, I was down in Macedonia a couple of years ago inspecting a railroad, and I stopped off for the night at a small Bulgarian village. The next day happened to be a *Prasdnik*, or saint's day, and the first thing in the morning I was awakened by a peculiar clacking sound which I couldn't make out. Calling my interpreter I found out from him that it was a *klepalo* for calling the people to church. The people there are too poor to afford a bell, and so in place of that they use a beam of oak hung from a rope tied about the center, and this beam is struck with a hammer, first on one side, and then the other. Sometimes an iron *klepalo* is used as well, and then they strike first the beam and then the iron bar, so as to vary the monotony of the call. I found that the wooden *klepalo* could be heard for a distance of about one and a half miles over land, and the iron one for over two miles. Now we can easily make a wooden *klepalo* for use in this camp, and then if Dutchy, or any of the rest of us, keep within a mile and a half of camp there won't be any trouble with the cook."

So we built a *klepalo*, getting from Lumberville a stick of seasoned oak, 1-1/2 inches thick, 6 inches wide and 4 feet long. A hole was drilled into the stick at the center, and by a rope passed through this hole the beam was suspended from a branch overhanging the camp. Jack, the cook, regularly used this crude device to call the hungry horde to meals.

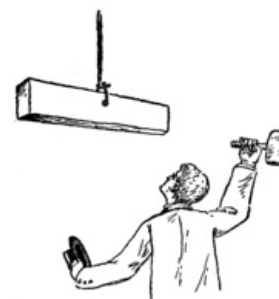

The *Klepalo*.

72

CHAPTER VII. SURVEYING.

One of the first things we did after getting fairly settled in our new quarters was to make a complete survey of Willow Clump Island and its immediate surroundings. Our surveying instruments were made as follows:

The Surveying Instrument.

Out of a 1-inch board we cut a base 15 inches long and 4 inches wide. In the center we sawed out a circular opening of about 3 inches diameter and covered this at the bottom by a circular piece 1 inch thick and 5 inches in diameter, thus forming a socket in which our compass fitted snugly. A hole 1 inch in diameter was drilled through the center of this circular piece to receive the pivot pin of a tripod. Across each end of the baseboard we secured a block 4 inches long, 2 inches wide and 1 inch thick. A 1-inch sight hole was drilled through each block at its center. A ring of cardboard, on which Uncle Ed marked with radial lines the 360 degrees of the circle, was placed over the compass socket, with the zero and 180 degree marks pointing toward the sight blocks. The outer faces of the end blocks were now wet with mucilage and a hair was stretched vertically across the center of each sight hole. The hairs were then adjusted by sighting through the holes and moving the nearer hair sidewise until it was exactly in line with both the zero and the 180 degree marks on the cardboard. Then a hair was stretched horizontally across the center of each sight hole. Great care was taken to place the hairs at exactly the same height above the baseboard. To protect the hairs after they were adjusted, they were covered with a piece of glass, which was secured in place by tacks driven into the wood with their heads projecting over the edges of the glass.

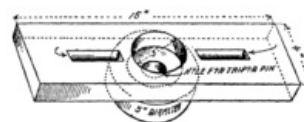

Fig. 71. Baseboard of the Surveying Instrument.

74

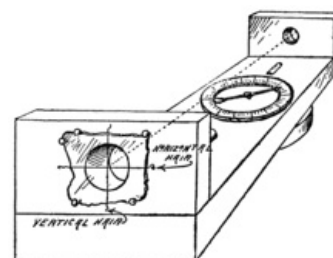

Fig. 72. Sighting Blocks on the Baseboard.

Spirit Levels.

From one of his pockets Uncle Ed produced two small bottles, the kind used for holding homeopathic pills. These he filled nearly to the top with water, corked them and wedged them into grooves cut lengthwise in the baseboard at opposite sides of the cardboard ring. These grooves were filled with putty, and to make sure that the bottles were level with the baseboard the latter was floated on a bit of quiet water and the bottles were pressed down at one end or the other until the bubble within rested at the exact center.

75

The Tripod.

The tripod head was formed of a wooden disk 5 inches in diameter, with a wooden pin projecting from its center adapted to engage the hole in the circular piece above referred to. To the bottom of the tripod head were nailed three blocks 2 inches long and 1 inch square in cross-section. The tripod legs were made of light strips of wood, 3/8 inch by 1 inch by 5 feet long, which we secured from one of the mills at Lumberville. Each leg was formed of two of these strips, nailed securely together to within 20 inches of the top. At the upper ends the strips were spread to receive the blocks on the tripod head. In this position they were held by headless wire nails driven into the ends of the blocks and fitting into holes drilled in the strips. For a plumb line we tacked a cord to the center of the tripod head, and attached a good-sized sinker to its lower end. In connection with this plumb line we occasionally used a protractor consisting of a semicircle of cardboard 5 inches in diameter, on which the degrees of the circle were marked off with radiating lines, as illustrated in Fig. 76.



Fig. 74. The Tripod Leg.

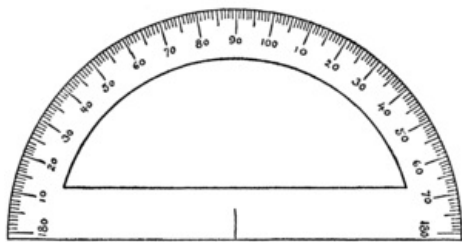

Fig. 76. The Protractor.

was tipped.

By holding the straight edge of this protractor against the base of the tripod, and noting the number of degrees between the 90 degree mark and the plumb line, we could tell at a glance at what angle from the horizontal the instrument

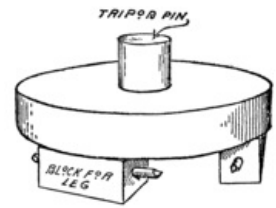

Fig. 73. The Tripod Head.

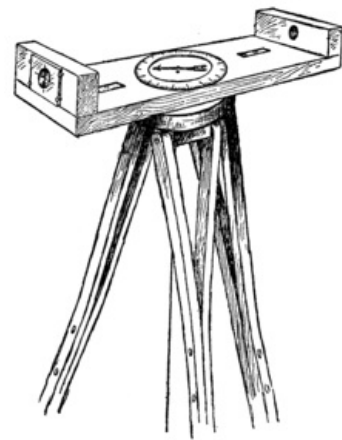

Fig. 75. The Surveying Instrument Complete.

Surveyor's Chain.

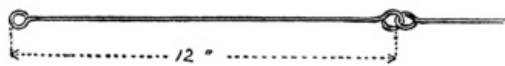

Fig. 77. The Surveyor's Chain.

exactly the same size and shape we used a form, around which they were bent. The form consisted of a 1-inch board in which two 1/2 inch holes were drilled, just 11-1/2 inches apart, measured from their centers. An oak pin, 1/2 inch in diameter, was driven into each hole and projected about an inch above the board. Two blocks of oak were secured to the baseboard, just before each pin, as shown in Fig. 78. This form gave great satisfaction. A groove was cut in the side of one of the pins to receive the ring of a completed link, while



Fig. 79. A Double-Ringed Link.

the wire was passed through this ring and bent around the peg to form the ring of the new link. After each link was formed it was carefully measured, and, if too long, was shortened by flattening the rings endwise, or, if too short, was lengthened by pinching together the sides of the rings. There were fifty links in our chain, and every tenth one was formed with a double ring at the end, so as to distinguish it from the rest (see Fig. 79).

We made a surveyor's chain of wire links, each 12 inches long, instead of 7.92 inches, which is the length of a standard surveyor's link. The wire we used was No. 16 galvanized iron, which was rather stiff and difficult to bend. In order to make all the links of

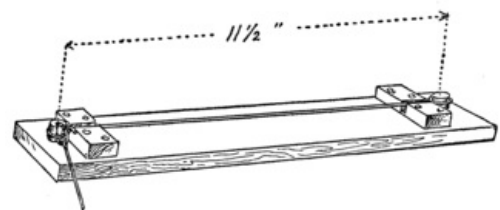

Fig. 78. Forming the Links.

The Surveyor's Rod.

We completed our outfit by making a surveyor's rod out of a straight stick of wood about 6 feet long. A target or sighting disk was mounted on the stick. This disk was 6 inches in diameter, and was sawed out of a 6-inch square board by making straight cuts across the corners and then smoothing off the edge to a perfect circle with a draw-knife. The thickness of the disk was only

76

77

78



Fig. 81. The Sighting Disk

1/2 inch. At the back of the disk we fastened a block of wood with a slot cut in it to receive the rod, as shown in Fig. 81. To hold the disk at different heights on the rod a small bolt was used. The nut on this bolt was slipped into a hole on the block at the bottom of the slot and held in place by driving in nails about it, as illustrated in Fig. 82. The bolt was then passed through the hole and threaded through the nut, with its inner end bearing against the rod. The disk could thus be held at any desired position by tightening up the bolt. A piece of white paper was now pasted over the disk. The paper was marked off into quarters, and opposite quarters were painted black so that it would be easy to sight, from a distance, the exact center of the target.

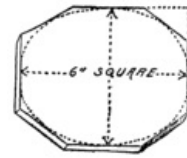

Fig. 80. Cutting Out a Disk.



Fig. 82. Nut Fastened in Block.

A Simple Method of Surveying.

Of course, none of us had studied trigonometry, but Uncle Ed devised a very simple method by which we could determine distances quite accurately without much figuring.

"If you will tell me the length of one side of a triangle and the angles it makes with the other two sides," said Uncle Ed, "I'll tell you the length of the other two sides and the size of the third angle. This is how I will do it:

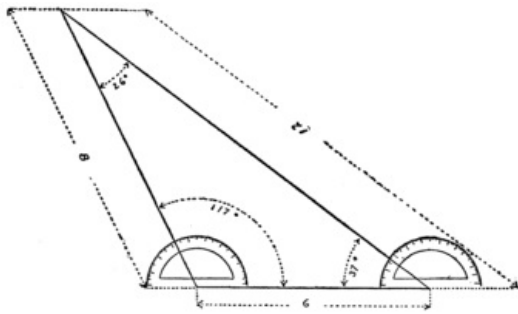

Fig. 83. Diagram of Our First Lesson in Surveying.

"Say the line is 6 inches long and one angle is 35 degrees, while the other is 117 degrees. Let us draw a 6-inch straight line. This we will call our base line. Now we will place the base edge of our protractor on the base line with its center at the right hand end of the line. At the 37 degree mark we will make a dot on the paper so, and draw a line from the right hand end of the base line through this dot. Now we will do the same thing at the opposite end, making a dot at 107 degrees from the line, and draw a line from the left hand end of the base line through this dot.

"If we extend these lines until they intersect, we will have the required triangle, and can measure the two sides, which will be found to be about 12 inches and 8 inches long, and the third angle will measure just 26 degrees. It doesn't make any difference on what scale we draw the triangle, whether it be miles, yards, feet, inches or fractions of an inch, the proportions will be the same. If the base line had been 6 half-inches, or 3 inches long, and the same angles were used, the other two lines would measure 12 half-inches, or six inches, and 8 half-inches, or 4 inches. If the base line were 6 quarter-inches long, the sides would be 3 inches and 2 inches long.

"Now, for example, I am going to measure the distance to that tree over there. Get out your chain and measure off a straight line 10 feet long. Now, I'll set the surveying instrument with the plumb-bob right over the end of this line, and sight through the two sight holes until I bring the two vertical hairs in line with each other and the tree. Look at the compass needle. It points to the 173 degree mark on the cardboard ring. Now, Bill, you hold the rod at the other end of our base line while I swing this instrument around and sight it. There, the needle points to 92 degrees, and subtracting this from 173 the difference, 81 degrees, is the angle at the right end of our base line. We'll do the same thing at the other end of our line. See, the compass needle points to 189 degrees, and now sighting to the pole at the other end of the line we find that the needle points to 268. The difference, 79 degrees, is therefore the size of the angle at the left end of our base line. Now we will draw this out on paper, as we did our first triangle, using quarter-inches to represent feet. Our base line was 10 feet long, and we will therefore draw a line 10 quarter-inches, or 2-1/2 inches long, on our drawing board. On this line we will construct the triangle, using the angles 81 and 79 degrees. There, that's how our triangle looks, and the right hand side measures 7-1/4 inches, while the left hand side measures 7-5/16 inches. That is, 29 quarter-inches for one side and 29-1/4 quarter-inches for the other. As each quarter-inch represents a foot, you will find that the tree is about 29 feet from the right end of our base line and 29 feet 3 inches from the left hand end. Of course, our instrument is not perfect, neither is our drawing; but if you measure it off with the chain you will see that I am not very far from correct."

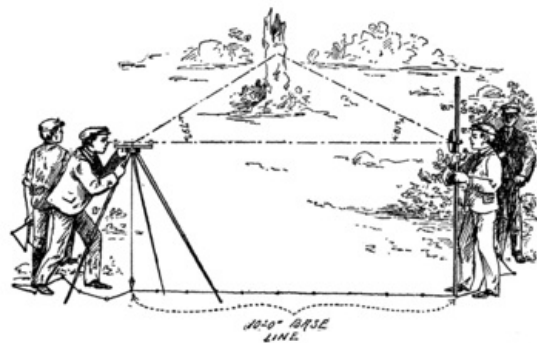

Fig. 84. Determining the Distance to the Tree.

Mapping the Island.

Most of our surveying was done by actual measurement, the surveying instrument being used

only to determine the exact direction of the measurement. However, there were some measurements which we could not make directly with the chain. For example, we wished to know just how far it was from our tent to the Jersey shore of the river. We measured off a base line along our shore 400 feet long and sighted to a point directly across the river from our tent. The angle in front of our tent was 90 degrees, and at the other end of the base line was 73 degrees. When we drew out our triangle on the scale of 100 feet to the inch we found that the shorter side directly in front of the tent was almost exactly 13 inches long. This meant that the river at this point was 1,300 feet wide, nearly a quarter of a mile. On the other side of the island we found, in the same way, that the river at its narrowest point was about 500 feet wide. This portion of the river we named Lake Placid, as the water was very still and quite deep. This was due to a sort of natural dam formed at the lower end of our island. The small island that Dutchy found was kite-shaped, with a tail of boulders which extended almost all the way across to a rocky point on the Pennsylvania shore. The channel between "Kite Island," as we called it, and Willow Clump Island was not more than fifteen feet wide in some places, and through this the water swept with a swift current down past a narrow neck of land to join the main current. This narrow stretch of land we named the Tiger's Tail, owing to its peculiar shape. It was in the hook at the end of this tail that we discovered the old bridge wreck above referred to. From the tip of the Tiger's Tail to Point Lookout, at the extreme upper end of Willow Clump Island, it was a little under a half-mile. The shore all along Lake Placid was very steep, except near Point Lookout. At one place there was a shallow bay which we called the lagoon.

CHAPTER VIII. SWIMMING.

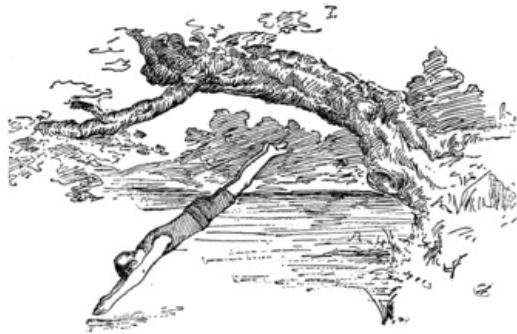

Fig. 85. The Diving Tree.

Lake Placid was a favorite swimming place for us. We used to plunge in from the branches of a tree which overhung the water a little ways above the lagoon and made a natural springboard. We could all swim like ducks, except Dutchy, who couldn't do anything but paddle. However, Uncle Ed was an expert, and he took Dutchy in hand and soon made a pretty good swimmer out of him. He also taught us some fancy strokes. Of course I took no record of these lessons. You would hardly expect me to sit on the bank with a book in hand jotting down notes while the rest were splashing around in the cool water having the best of fun in the world, and even if I had, I wouldn't republish the notes here, because whoever heard of a

boy learning to swim while reading a book on the subject? A beginner had better leave books alone and plunge right into the water. He will soon learn to keep himself afloat and can then practise any fancy strokes that he sees others try. Then, again, don't try to learn in shallow water, because you will never do it. Of course it doesn't pay to jump into water that is over your head unless there is a good swimmer near by to help you out. But you will never learn to swim until you have become accustomed to putting your head under water. You can not swim with a dry face. The first time we went swimming, we couldn't persuade Dutchy to try it. The water was deep right up to the very bank and he had never been in over his head. Instead he sat up in the diving tree swinging his feet and trying to hide the fact that he was having a dull time.

"Say, we've got to douse that fellow," said Reddy.

"You're right; he needs a wash," said Jim. "Let's sneak up behind him and chuck him in."

They landed a little ways up the stream behind a large bush and then crept down stealthily on their victim. But Dutchy had his suspicions aroused and saw them coming. He scrambled out of the tree in a jiffy and tore off into the woods as fast as his legs could carry him.

Swimming on a Plank.

We didn't expect to see him again that afternoon, for the pace he was leading should have carried him miles in no time; but while he couldn't swim, Dutchy had his own ideas of fun on the water. It was about twenty minutes later that we saw him coming down-stream lying full length on one of the 2-inch planks taken from the bridge wreck. He was paddling himself along with arms and legs hung over the sides of the plank. We all gave him a cheer, and then started out to have some fun with him. We tried to pull him off his raft, but he stuck on like a leech. It was only when we made his craft turn turtle that Dutchy got his head under water. But it wasn't a moment before he scrambled back on top again, gasping and sputtering to get the water out of his nose and mouth.



Fig. 86. Swimming on a Plank.

Uncle Ed all this time had been sunning himself on the bank, when suddenly he uttered a shout of

warning. We were right at the mouth of the mill-race. For the moment we forgot about Dutchy, and swam out for shore. Before we realized it Dutchy was caught in the current, and was being swept full tilt down the stream. My but wasn't he scared. I can see him yet clinging for dear life to the plank, his face the color of ashes and his eyes bulging out in terror. First he tried to make for the bank, but the water was so swift that when the front end of the board struck land the rear end swung around in a circle, carrying him on again, but backward this time, before we could reach him. Two or three more times the plank struck the bank and turned him around, while we raced along the high bank, scrambling down to catch him every time he headed for shore, but each time just missing him. Then he swung out past the Tiger's Tail into the open river just above the rapids. Fortunately he was going along headforemost this time, and Uncle Ed, who had just arrived, panting and breathless, from running, shouted to him to keep his head and steer for a narrow opening between two jutting boulders. I don't know whether Dutchy did any steering or not, but the raft shot straight through the opening, and was lost in a cloud of spray. In a moment he reappeared below the rapids, paddling like mad for a neck of land on the Pennsylvania side of the river.

Dutchy would never own up that he was afraid. He never told a lie under other circumstances, but when it came to a question of courage he had the habit of stretching facts to the very limit. Even in this case, he said that he started out with the idea of shooting the rapids, and if we hadn't flustered him so, he would not have bumped into the bank and turned about so many times. Dutchy was a very glib talker. He nearly persuaded us that it was all done intentionally, and his thrilling account of the wild dash between the rocks and through the shower of spray stirred us up so that we all had to try the trick too.

Shooting the Rapids.

The next day, while Uncle Ed was taking a nap, we stole off to the upper end of Lake Placid, each one towing a plank. We needn't have been so afraid of Uncle Ed, for we found out later that he intended to try a plank ride through the rapids himself next time he went in swimming. Down Lake Placid we paddled in single column to the mill-race. In a moment the current had caught us and we were off. I shall never forget the thrilling ride down the swirling mill-race, the sudden pause as we shot out into the open river, the plunge between the boulders and the dive through the spray. It was all over too soon. Something like coasting-whiz, whiz-z-z, and a half-mile walk. Were it not for the trouble of hauling the planks back by the roundabout course along the Pennsy shore we would have thought shooting the rapids a capital game.

Restoring the Drowned.

It was on the second day after Dutchy's exploit of the rapids that Bill came so near drowning. He probably would have drowned if Uncle Ed hadn't been on hand to work over him. Bill was a fine swimmer, but even the best of swimmers will sometimes get a cramp, so it is never safe for any one to go into the water without some one at hand to help him out in case of accident. In the present case Bill was doing some fancy strokes by himself over near the Pennsy shore, while the rest of us were watching Uncle Ed give Dutchy a lesson in swimming. All of a sudden Bill threw up his hands and sank. I happened to glance up as he did it. We thought he was fooling at first, but soon made out that he was in genuine trouble. Uncle Ed dropped Dutchy to my tender care, and raced over with a powerful stroke to the spot where he had last seen his nephew. He failed to find him on the first dive, but the second time was successful and he carried the lifeless body to



Fig. 87. Pressing the Water out of the Stomach.

the Pennsylvania shore. In the meantime I had landed Dutchy and with the rest of the boys had crossed the lake. Uncle Ed first laid Bill on his back and hastily wiped dry the mouth and nostrils. Then he pried his jaws apart, holding them open with a piece of wood wedged in between the teeth. After which he turned him on his face over a log which was placed under his stomach. By stomach I do not mean the bowels, but the real stomach, which lies just under the ribs in front. Then he pressed with a good weight on the back directly over the log for nearly a minute, causing the water to flow out of the

mouth. Dutchy had by this time rowed across in the scow, in which fortunately there happened to be some of Uncle Ed's clothing. This he took and rolled into a bundle, then Bill was laid on his back over the roll of clothing, which was arranged to raise the pit of his stomach above the rest of his body. Uncle Ed now wrapped a handkerchief around his forefinger, and with it wiped out Bill's mouth and throat. Reddy, who was the least excited of the lot, was told to draw Bill's tongue forward so as to prevent it from falling back and choking the windpipe. This he did with the dry part of the handkerchief, drawing the end of the tongue out at the corner of the mouth, and holding it there while Uncle Ed and I started the pumping action, which produced artificial respiration. I was directed to grasp Bill's arms just below the elbows, and swing them vertically in an arc until the hands met the ground again above the head. This expanded the chest. Uncle Ed at the same time stood over the body with his elbows on his knees and hands extended, as illustrated in Fig. 88. Then I swung the arms up and back to the sides of the body, but just before the hands touched the ground Uncle Ed seized the body in both hands just below the ribs, and as soon as I touched the arms to the ground he swung forward with all his weight

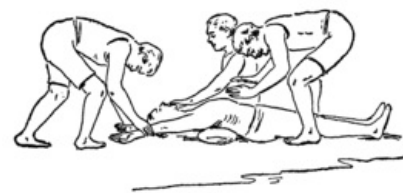

Fig. 88. Expanding the Chest.



Fig. 89. Squeezing out the Air from the Lungs.

on his hands, squeezing the waist and pushing upward so as to force out the air in the chest. Then he slowly counted, one, two, three, four, all the time steadily increasing the pressure, until at the signal four, with a final push, he shoved himself to the first position, shown in Fig. 88. At the same signal I drew the arms up again over the head, and held them there while Uncle Ed again counted four; then I returned the arms to the sides, and Uncle Ed repeated the squeezing process. These movements were continued for about three minutes, and then Bill gave a short, faint gasp. We kept on with the artificial respiration, assisting the gasps, which gradually grew stronger, until they had deepened into steady breathing. Then we stripped off the wet bathing suit, and wrapping Bill in Uncle Ed's clothing, laid him in the bottom of the boat. While Dutchy hurried the boat across, Uncle Ed rubbed the patient's arms and legs. The rest of us swam over and ran for blankets from the tent. Bill was wrapped in one of the blankets and the other was used as a stretcher, on which we carried him to the tent. Then one of us was sent post-haste across to Lumberville for some whiskey, which was diluted in hot water and given the patient a teaspoonful at a dose, every fifteen minutes at first, and then at less frequent intervals. Uncle Ed kept Bill in bed all the next day for fear of congestion of the lungs. He told us that unless the patient kept perfectly quiet for a couple of days, he was liable to be seized with a sudden attack of hard breathing that might choke him to death in a short time. To stop such an attack he told us that the best plan was to apply a mustard plaster to the chest, and if the patient commenced to gasp, to start pumping the arms and squeezing the waist so as to help him breathe. After Bill had come around and was himself again Uncle Ed gave us a thorough drill in methods of restoring the drowned. He laid down on the grass and made us practise on him the various directions which he gave us.

92

How to Work Over a Patient Alone.

"If you boys hadn't been so excited," he said, "I would have made you rub Bill's body and limbs while we were pumping the air into him, but I knew you would get in the way, and be more of a bother than a help. You must learn to be calm in any accident; excitement doesn't pay. Keep steadily and slowly at your pumping, for you might have to do it for four hours before the patient comes to." He taught us just how to swing the arms and squeeze the ribs to best advantage, and how to hold the tongue without getting in the way of the arms as they were pumped back and forth. There was also a special way of rubbing the arms and legs. The limbs were always rubbed

93



Fig. 90. Working alone over a Patient.

upward, or toward the body, with the bare hands, or a dry cloth if there was one at hand, but this all had to be done without interfering with the pumping action. "If the patient doesn't come around in five minutes," he said, "turn him on his face again over the roll of clothing, or any other suitable substitute, and press out the water from the stomach, rolling him first to one side and then to the other; be sure to get all the water out." When we had learned our lesson well, Uncle Ed took Dutchy for his patient, and proceeded to show us how a man could work over him alone. First he went through the operation of squeezing the water out of him, and drying his nose and mouth, much to the patient's discomfort; then he drew Dutchy's tongue out of the corner of his mouth, holding it there by closing the jaws on it, and holding the jaws together by passing a handkerchief over his chin and lapping it over his head. After that he began to pump, seizing the patient's arms and swinging them up over the head and back, as before. Just as the arms were dropped back to the sides of the body, he squeezed them in against the ribs, at the same time drawing upward toward the head and counting four each time, as he had done before. But the lesson was abruptly interrupted by Dutchy, whose imagination was worked up to such a pitch that I actually believe he thought he had been drowning. Anyway, he squirmed out of Uncle Ed's grasp, and wouldn't play patient any longer. For several days after that we couldn't persuade him to venture near deep water.

94

CHAPTER IX. BRIDGE BUILDING.

95

Willow Clump Island was, for the most part, a trackless wilderness, and as soon as we had made our map we laid out roads to the different important points. Our main highway ran from Point Lookout to Tiger's Tail. This road was made rather winding, to add to its picturesqueness, and from it a number of shorter roads branched off.

Spar Bridge.

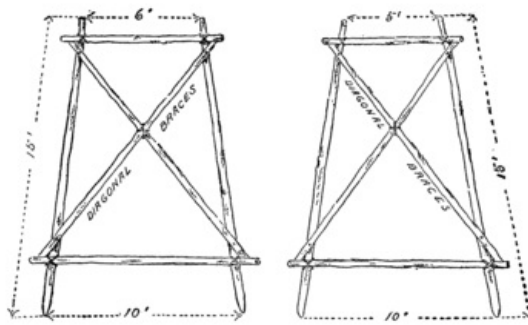

Figs. 91 and 92. Frames for the Spar Bridge.

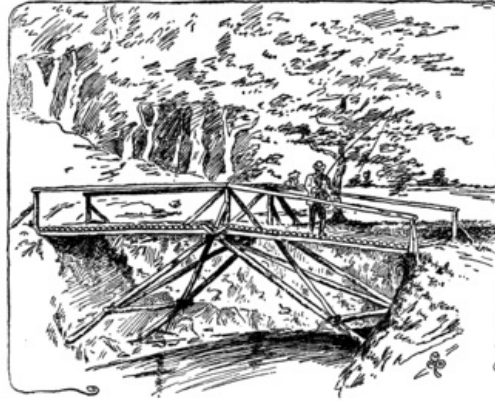

Fig 93. The Spar Bridge.

We ran a bridge across the mill-race at its narrowest point. This bridge was made of trees which we had cut down in making our road. It was quite a piece of engineering, built under Uncle Ed's guidance. Two frames were made of the shape shown in Figs. 91 and 92. The side sticks were 15 feet long and spaced about 10 feet apart at the base by crosspieces. At the upper end one frame was made 6 feet wide and the other 5 feet wide. The side and cross spars were mortised together and secured by lashing a rope around them. To make the frames more rigid we braced them with diagonal braces nailed on. When completed we set the frames up on opposite sides of the stream and with ropes carefully lowered their upper ends until they interlocked, the side spars of each frame resting on the cross spars of the other. In the angles formed by the crossing side spars a center spar was laid, and a number of floor beams or spars were stretched to this from the opposite shores. On these a flooring was spread made of saplings, cut and trimmed to the right size. A rustic railing on each side of the bridge completed the structure.

The Rope Railway.



Fig. 94. The Swing Seat.

The mill-race was crossed further down by a rope line on which we rigged a traveling carriage. A light manila rope was used, anchored to a tree at each side about fifteen feet from the ground. A pulley block with a wheel or sheave 4 inches in diameter was mounted to travel on the rope. Suspended from this block by means of fall and tackle was a swing seat. This, as shown in Fig. 94, was merely a board fastened with four rope strands to the ring of the tackle block. A single rope was used, with the ends tied firmly together. The loop thus formed was passed through the ring of the tackle block and the opposite ends were twisted over the ends of the seat board in the manner illustrated in Fig. 95. The tackle blocks were quite small, having 2-inch sheaves, and they, together with the large pulley or "traveling block," as we called it, cost us about \$2.50. Two light ropes were fastened to the large traveling block, each rope long enough to reach across the stream. The ropes extended to opposite anchorages, where each was passed over a branch of the tree and belayed on a cleat within easy reach. A fellow could draw himself up clear of the ground by pulling on the free end of the fall, as a painter does; then tying the swing fast in this position, he would pull himself across the stream by means of the rope stretched to the opposite anchorage. The swing could be drawn back by the next one who wanted to cross. We also used this aerial line for transporting loads from one island to the other.

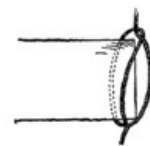

Fig. 95. Tying the Ropes to the Seat.

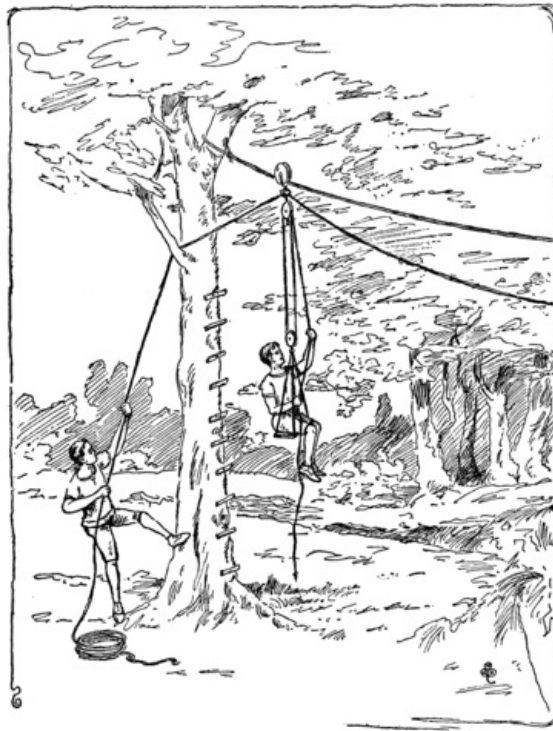

Fig. 96. The Rope Railway.

Suspension Bridge.

Our aerial railway didn't last long. We soon tired of it, and instead utilized the materials for a rope suspension bridge. We procured from Lumberville half a dozen old barrels and used the staves as a flooring for the bridge. The staves were linked together by a pair of ropes at each end woven over and under, as indicated in the drawing Fig. 97. Notches were cut in the staves to hold the ropes from slipping off. The



Fig 97. Barrel-stave Flooring.

flexible flooring thus constructed was stretched across the river and secured to stakes driven firmly in the ground. A pair of parallel ropes were extended across the stream about three feet above the flooring, with which they were connected at intervals of five feet. The bridge was 25 feet long, and while rather shaky, owing to the fact that there were no braces to prevent it from swaying sidewise, still it was very strong and did excellent service.

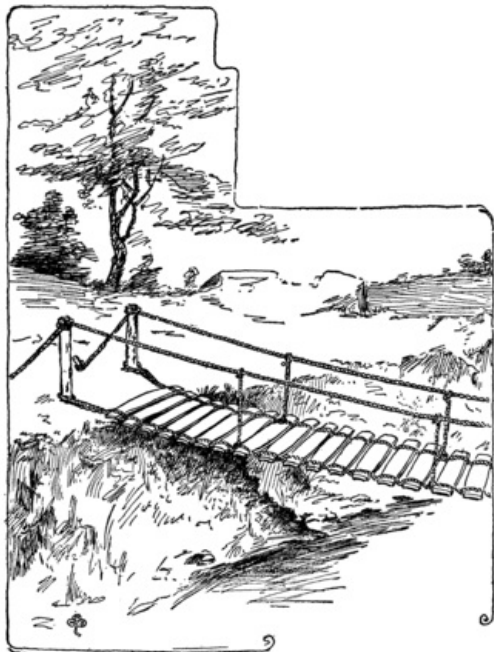

Fig. 98. The Suspension Bridge.

Pontoon Bridge.

At the head of the mill-race, where the channel was fifty feet wide, we built a pontoon bridge. We were fortunate in securing six good cider barrels at low cost, also a quantity of "slabs" from one of the sawmills of Lumberville. "Slab" is the lumberman's name for the outside piece of a log which is sawn off in squaring up the sides. We made a raft of these materials and floated them down the river to Lake Placid. The bridge was made by anchoring the barrels in the channel about eight feet apart, and laying on them the floor beams, which supported a flooring of slabs. The floor beams were narrow planks 1 inch by 4 inches, taken from the bridge wreck, and they were placed on edge to prevent sagging. Of course we had no anchors for securing the barrels, but used instead large stones weighing about 100 pounds each, around which the anchor lines were fastened. We found it rather difficult to sink these improvised anchors at just the right places, for we were working at the very mouth of the mill-race, and were in constant danger of having our scow sucked down into the swirling channel. Once we were actually drawn into the



Fig. 99. The Pontoon Bridge.

mill-race and tore madly down the rushing stream. By Bill's careful steering we managed to avoid striking the shore, and just as we were off the Tiger's Tail Reddy succeeded in swinging a rope around an overhanging limb and bringing us to a sudden stop. A moment later we might have been dashed against the rocks in the rapids below and our boat smashed. Shooting rapids in a scow is a very different matter from riding through them on a plank.

The King Rod Truss.

Our bridge building operations were not entirely confined to the island. Two of them were built on the Schreiner grounds at Lamington. Reddy Schreiner's home was situated a little distance above the town where Cedar Brook came tumbling down a gorge in the hills and spread out into the Schreiners' ice pond. Thence it pursued its course very quietly through the low and somewhat swampy ground in the Schreiners' back yard. Over this brook Reddy was very anxious to build a bridge. Accordingly, before returning to school in the fall Bill made out a careful set of plans for the structure, and after we had gone the rest of the society, under Reddy's guidance, erected the bridge.

The structure was a cross between a suspension bridge and a spar bridge. The banks of the stream were so low that, instead of resting the floor of the bridge on top of the inclined frames, as we had done over the mill-race, it was suspended from the spars by means of wires. The crossing ends of the spars were nailed together and their lower ends were firmly planted about four feet apart in the banks of the brook. A stick nailed to the apex of each pair of spars served temporarily to brace them apart. The center cross beam of the bridge was now suspended from the spars by means of heavy galvanized iron wire (No. 14, I should say). The beam was hung high enough to allow for stretch of the wire, making the roadway incline upward from both sides to the center. Aside from carrying the floor of the bridge, this beam was used to brace the inclined spars when the temporary crosspiece was removed. The ends of the beam projected about thirty inches beyond the bridge at each side, and they supported braces which extended diagonally upward to the crossing ends of the spars. When this was done the temporary crosspiece above referred to was removed. As the span between the center cross beam and the banks was a little too long to provide a steady floor, a couple of intermediate cross beams were suspended from the inclined spars. The floor beams were then laid in place and covered with a flooring of slabs.

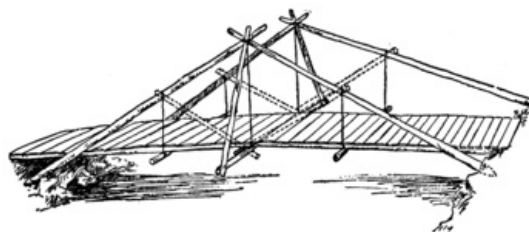

Fig. 100. The King Rod Bridge.

Stiffening the Bridge.

The bridge was a pretty good one, except for a slight unsteadiness between the center and either end. When Uncle Ed saw it he showed us at once where the trouble lay. Our intermediate cross beams were hung from the center of the spars, and consequently made them bend, because the strain came across their length, while at the center of the bridge there was no chance for the spars to bend, because the strain was exerted along their length, that is, it tended merely to push the ends of the spars deeper into the banks. To remedy the trouble he proposed propping up the center of each spar with a brace running from the center crosspiece. The dotted lines in Fig. 100 show how these braces were applied. They made the floor perfectly solid throughout, and gave the bridge a much better appearance. Uncle Ed told us that the structure might be called a "king rod truss," except that in place of rods we had used wires.



The King Rod Bridge.



The Bridge over Cedar Brook Gorge.

The King Post Bridge.

The other bridge on the Schreiner property was built in the following summer, just before we started on our second expedition to Willow Clump Island. It spanned the brook at the gorge, and was therefore a more difficult engineering feat. Mr. Schreiner himself asked us to build it, and we felt greatly honored by the request. A search was made in the Van Syckel library for a suitable type. At last we found one that seemed properly suited to the requirements. It was called a "king post truss," and was very similar to the king rod bridge. While the design of the bridge was simple, yet it required some ingenuity to put it together. In setting up the other bridge the scow had been anchored in the center of the stream and used as a working platform, from which it had been an easy matter to put the various parts together. In this case our scow was obviously of no use, so we laid a couple of long logs across the chasm, and a few slats were nailed across them to provide a temporary bridge or working platform. The platform sagged considerably at the center, because the span was fully eighteen feet; but the logs were large, and we knew they were strong enough to support our weight. However, as an extra precaution, we tied the ends to stakes driven in the ground, so that they could not possibly slip off the banks.

First we set about constructing the king posts, which were made as shown in Fig. 101. Two stout posts 7 feet long were connected at the top by a tie stick, which spaced them 4 feet apart. To

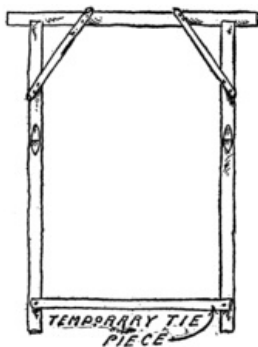

Fig. 101. The King Post Frame.

make a secure fastening they were notched together and strengthened with diagonal braces. Each king post was notched on opposite sides, at about thirty inches from the top. A temporary tie piece was also nailed across the lower ends of the king posts. The frame thus formed was set up at the center of the span and temporarily held by nailing the lower tie piece to the working platform. Four stout spars were now cut, each about fifteen feet long. Taking a pair at a time, we planted their lower ends firmly in the opposite banks and sawed off their upper ends until they could just be hammered into the notches in the king post. This required careful fitting, but by making the spars a little too long to start with, and then shaving them down with a draw-knife, we managed to make fairly good joints. A couple of long wire nails in each spar made the structure perfectly secure. The king posts were now sawed off just above the temporary tie piece, and the permanent cross beam was fastened to these ends with straps of heavy wire wound tightly about them. The working platform sagged so much that we were able to lay this cross beam above it. From the ends of the cross beam diagonal braces extended to the king posts (Fig. 103). Our working platform was now removed and replaced with the permanent floor beams, which were firmly nailed to the center cross beam and to the inclined spars at the shore ends. The floor beams were quite heavy and needed no support between the king posts and shore. A rustic floor was made of small logs sawed in two at Mr. Schreiner's sawmill. Light poles were nailed to the

Fig. 102. The King Posts Set in Position.

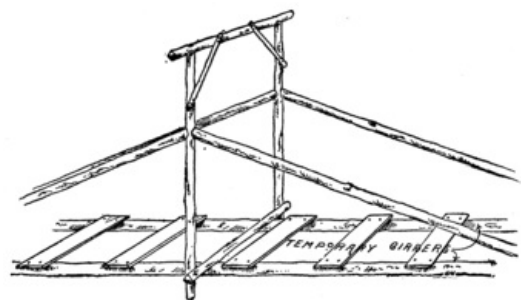

Fig. 102. The King Posts Set in Position.

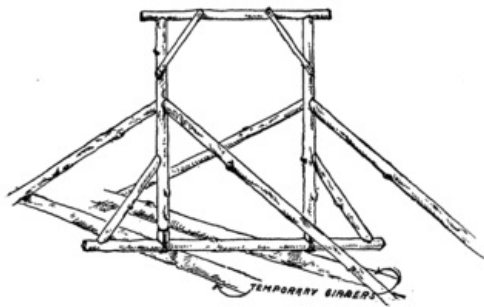

Fig. 103. The Permanent Cross Beam Made Fast.

flooring along each edge, giving a finish to the bridge. We also provided a rustic railing for the bridge of light poles nailed to the king posts and the diagonal spars.

CHAPTER X. CANVAS CANOES.

Like all inhabitants of islands, we early turned our attention to navigation. Our scow was serviceable for transporting materials back and forth across the strips of shallow water between our quarters and the Jersey shore. We never attempted to row across, because progress would have been entirely too slow, and we would have drifted down to the rapids long ere we could reach the opposite side. But on Lake Placid matters were different. Although there was no settlement near us on the Pennsylvania shore, to occasion our crossing the water for provisions and the like, yet the quiet stretch was admirably suited to boating for pleasure, and mighty little pleasure could we get out of our heavy scow.

Uncle Ed's Departure.

Owing to a sudden business call Uncle Ed left us after he had been with us nearly three weeks. But, before going, he explained carefully to Bill just how to construct a canvas canoe. Jack, the cook, who was anxious to lay in a second supply of provisions, accompanied Uncle Ed as far as Millville, the next town below Lamington. Here Uncle Ed bought five yards of canvas, 42 inches wide, several cans of paint and a quantity of brass and copper nails and tacks. These supplies, together with the food provisions that Jack had collected, were brought to us late in the afternoon by Mr. Schreiner. Mr. Schreiner also brought the necessary boards and strips of wood for the framework of our canoe.

A Visit from Mr. Schreiner.

We invited Mr. Schreiner to spend the night with us, and this he did after fording with some difficulty the swift-running river. In the morning we showed him our quarters, our filter, the roads we had built, the spar bridge across to Kite Island, our surveying instrument and the chart we had made of the vicinity. He was greatly pleased with our work, and it was then that he gave us an order for the bridge over the gorge. From that day on he became our staunchest ally, so that when my father and Mr. Van Syckel complained that we were loafing away a lot of time which could be more profitably spent in study or work, Mr. Schreiner stood up for us and declared that our experiences on the island were doing us far more good, both physically and mentally, than any other work that they could conceive of; that before condemning us they should pay us a visit and see how we were employing our time.

The Sailing Canoe.

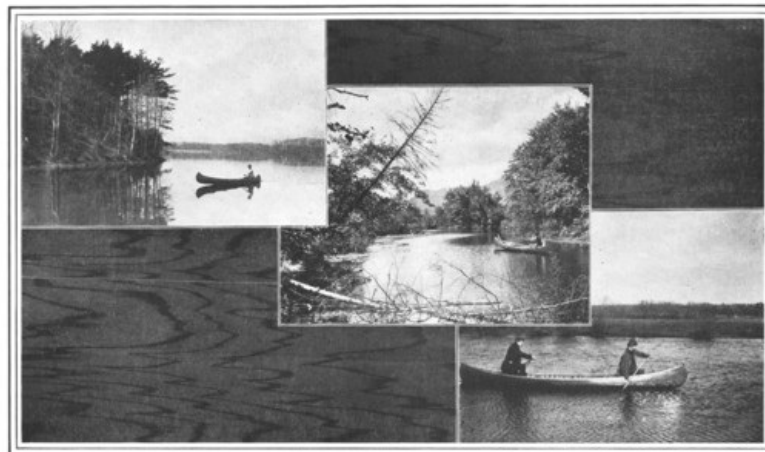

Exploring the River in the Indian Canoe.

Immediately after Mr. Schreiner's departure we started work on the canoe. A strip of spruce 1 inch thick, 3 inches wide and 12 feet long served as the keelson. At the stern a post 1-1/2 inches thick, 3 inches wide and 13 inches high was secured to the keelson with brass screws. This was

braced as indicated in Fig. 104. At the bow a stem piece was attached to the keelson. This stem was cut to a somewhat semicircular form, as shown in Fig. 105. The outer edge was tapered with a draw-knife to a thickness of 1/4 inch and a brace was nailed to the inner edge. Our

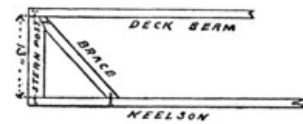

Fig. 104. Stern Post of the Canoe.

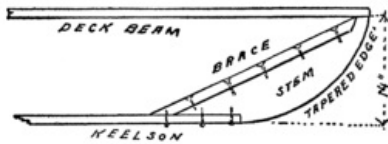

Fig. 105. Stern of the Canoe.

next work was to cut out three forms, one of the shape shown in Fig. 106 and two like that shown in Fig. 107. The first form was set up on the keelson midway between the stem and stern, and the other two were spaced about four feet each side of the center form. The

center form was used only for shaping the frame of the boat, and was not intended to be permanently affixed to the canoe. Therefore, we fastened it to the keelson very lightly, so that it could be readily removed. The other two forms, however, were made permanent parts of the frame, serving as bulkheads. The gunwales were now secured in position. These were of spruce 3/4 inch thick and 2 inches wide. The ends were beveled off so as to neatly fit the stem piece and the stern post, to which they were fastened by brass screws. Then we applied the longitudinal strips, or rib bands, which were of 1/4-inch thick spruce 1 inch wide. Ten of these bands

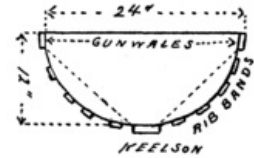

Fig. 106. Center Form.

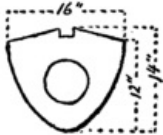

Fig. 107. Bulkheads.

were used, equally spaced apart on the center form, to which they were lightly tacked; but they were nailed securely to the bulkheads and the stem piece and stern post. The cross ribs were made of barrel hoops which we had soaked in water for a day or so to render them pliable enough to be bent into place. These hoops were split to a width of 1/2 inch, and secured first to the keelson, then to the longitudinal strips and finally to the gunwales. Copper tacks were used for nailing the ribs in place, and these were long enough to be passed through the rib bands and clinched on the outside. Forty cross ribs were nailed on, and at the center of the canoe they were spaced about three inches apart. The center form was then removed and cut along the dotted lines shown in Fig. 106. The semicircular pieces thus obtained were now strengthened with strips on their inner edges, and wedged in between the keelson and the gunwales, to which they were nailed, as shown in Fig. 108. A pair of cleats nailed to the cross ribs served as supports for the seat of the canoe. The frame of the boat was completed by nailing in place two deck beams of 1/2-inch square pine and four corner pieces between the gunwales and the bulkheads, so as to make an elliptical well hole or deck opening. Before laying on the canvas covering the edges of the gunwales, keelson, deck beams, stem and stern posts were smoothed down with sandpaper.

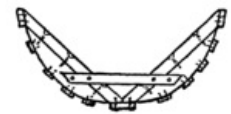

Fig. 108. Center Braces.

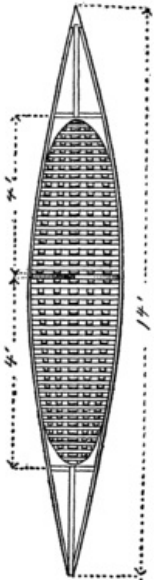

Fig. 109. Top View of the Canoe Frame.

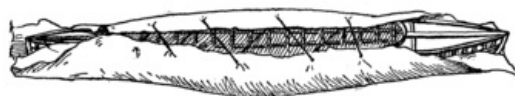

Fig. 111. Lacing the Canvas on the Frame.



Fig. 110. Side View of the Canoe Frame.

Stretching on the Canvas.

The frame was laid in the center of the canvas and the latter drawn around it. Then with a large needle and strong twine we sewed both edges of the cloth together with long stitches, lacing the canvas over the frame as a shoe is laced over a foot. This done, the boat was turned deck downward and the canvas was tacked to the keelson. In each case, before driving in a tack a

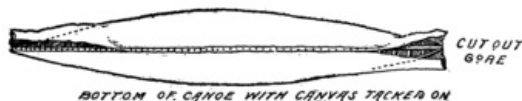

Fig. 112. Tacking the Canvas to the Keel.

daub of white lead was applied, to water-proof the spot. At the stem and stern a gore (narrow triangular piece) was cut out of the canvas so as to make it lie smooth on the frame, and white lead was painted in between the overlapping edges. The canoe was then turned deck upward and the lacing tightened, while we carefully worked out all wrinkles in the cloth. After tacking the canvas along the gunwales on the outside, it was trimmed off, leaving sufficient margin to be brought over the gunwales and tacked inside. Two triangular pieces were cut out for the decks, and these were lapped over the outer canvas and tacked to the gunwales. A narrow molding along the edge of the boat served to cover the tack heads and added a certain finish to the canoe. A keel plate 2 inches wide and 1 inch thick was attached to the outside of the boat, and then, after wetting the canvas, it was given a coat of white lead and oil. When this was perfectly dry it was sandpapered and the second coat applied.

After tacking the canvas along the gunwales on the outside, it was trimmed off, leaving sufficient margin to be brought over the gunwales and tacked inside. Two triangular pieces were cut out for the decks, and these were lapped over the outer canvas and tacked to the gunwales. A narrow molding along the edge of the boat served to cover the tack heads and added a certain finish to the canoe. A keel plate 2 inches wide and 1 inch thick was attached to the outside of the boat, and then, after wetting the canvas, it was given a coat of white lead and oil. When this was perfectly dry it was sandpapered and the second coat applied.

The Rudder.

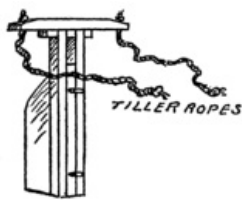

Fig. 113. The Rudder.

we ran our tiller rope clear around the boat, through screw eyes in the gunwales and a pulley at the stem, so that the steersman could guide his craft from any point in the canoe.

The canoe was now complete except for the rudder, which was cut from a 1/2-inch board to about the shape shown in Fig. 114. Strips 1-1/2 inches wide and 1/2 inch thick were nailed to each side of the blade, forming a post, to the top of which a crosspiece or tiller was fastened. A cleat nailed to the pillar at each side of the rudder post served to greatly strengthen the joint. The rudder was hinged to the canoe by a rod, which passed through four brass screw eyes, two threaded into the rudder and a corresponding pair screwed into the stern. For convenience in steering

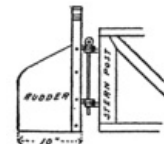

Fig. 114. The Rudder Hinge.

The Deep Keel.

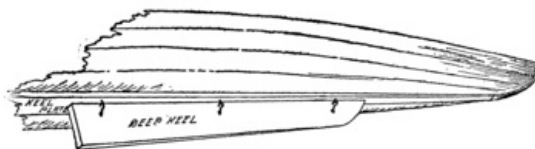

Fig. 115. Bottom of Canoe, Showing Deep Keel.



Fig. 116. End View, Showing Deep Keel.

We planned to use our canoe as a sailboat, and had to provide a deep keel, which, for convenience, was made detachable. This keel was 6 inches wide, 1/2 inch thick and 6 feet long, and was fastened at the center of the canoe. Screw eyes about twelve inches apart were threaded alternately into opposite sides of the keel plate. Corresponding hooks were attached to the keel in position to hook into the screw eyes, and thus hold the keel firmly in place.

Canoe Sails.

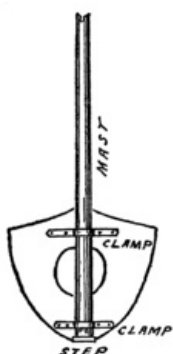

Fig. 117. The Mast Step.

Our boat was fitted with two masts, a mainmast and a mizzen or dandy mast. The former was 6 feet long and the latter 4 feet long, and each measured 1-1/2 inches in diameter at the base, tapering to about 1 inch diameter at the upper end. They were held in brass bands, or clamps, bent around them and secured to the bulkheads, as shown in Fig. 117. The sails were of the lanteen type. The mainsail measured 8-1/2 feet along the boom, 9-1/2 feet along the yard and 10 feet at the leach. The dimensions of the mizzen sail were: along the boom, 5 feet; along the yard, 5-1/2 feet; and at the leach, 6 feet. The boom was attached to a strap of leather on the mast, and was thus given freedom to swing around in any desired position. The yard was similarly attached, and was raised by a cord, which passed through pulleys at the top and at the base of the mast and extended to a cleat within easy reach of the occupant of the boat. A double paddle was fashioned from a board 1 inch thick, 6 inches wide and 6 feet long. The blades were shaved down to a thickness of 3/8 of an inch at the edges.

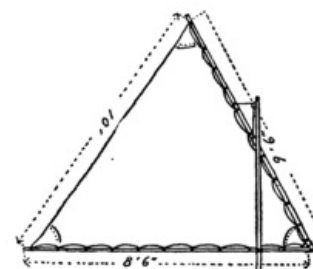

Fig. 118. The Mainsail.

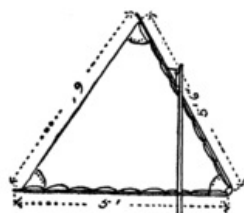

Fig. 119. The Mizzen Sail.

It will be observed that we used no iron in the construction of this boat. Uncle Ed has warned us not to, because iron rusts out so easily and is apt to damage both the canvas and the wood with which it is in contact.

A canoe is rather a tipsy thing to sail in, as we soon learned, and it was lucky that we could all swim, else our vacation might have ended very tragically; for the very first time Bill and I tried the boat an unexpected gust of wind struck us and over we went. We were very poor sailors at first, but it didn't take us long to catch on.

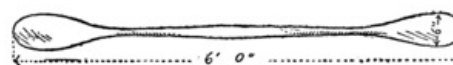

Fig. 120. The Double Paddle.

Lee Boards.

One thing that bothered us greatly in sailing was the keel of our canoe. It was forever getting twisted, particularly when we tried to make a landing. There were only a few places along the island where the water was deep enough to permit our coming right up to shore without striking the keel. The fastening was not very strong, and every once and awhile it would be wrenched loose. The matter was made the subject of a special letter to Uncle Ed, and in due time his answer was received. As usual, he offered a first-class solution of the difficulty. "Don't use a keel," he wrote; "lee boards are much better." Then he went on to explain what was meant by lee

boards: "The leeward side of a boat is the opposite of the windward side; that is, that side of the boat which is sheltered from the wind. Lee boards, then, are boards which are hung over the lee side of a boat to prevent it from drifting to leeward, and they serve to take the place of a keel or centerboard."

Following Uncle Ed's direction we fastened a strip of wood across the canoe about six feet from the bow, nailing it firmly to the gunwales. This provided a support to which the lee boards were secured. The lee boards were paddle-shaped affairs of the form and dimensions shown in Fig. 121. Each paddle near the top was hinged to the end of a board three inches wide and a foot long. The paddle was held at right angles to the board by means of a hook.

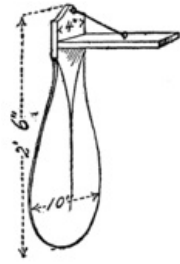

120

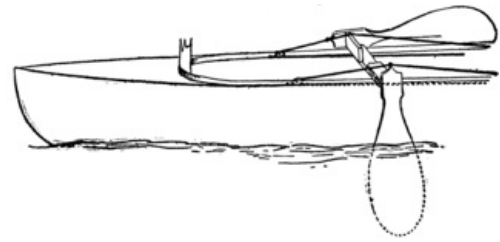

Fig. 122. Section of the Canoe, Showing Lee Board.

Each board was fastened with door hinges to a baseboard which extended the width of the boat and was attached to the crosspiece of the canoe by means of a couple of bolts. The bolt heads were countersunk, so that the hinged boards could lie flat over them. To the top of each lee board two ropes were attached, one passing forward around a pulley and thence back to a cleat within easy reach of the occupant of

Fig. 121. A Lee Board.

the canoe, and the other passing directly back to this cleat. By pulling the former rope the lee board was lifted out of the water, while the latter rope was used to swing the board into working position. When tacking to port (left), the board on the left side of the canoe was lowered and the other was raised, as shown in Fig. 123, and when tacking to the starboard (right) the board on the right side was lowered, while the left one was raised.



121

Fig. 123. The Lee Boards in Use on Canoe.



The Indian Canoe Fitted with Lanteen Sail and Lee Boards.

The Indian Paddling Canoe.

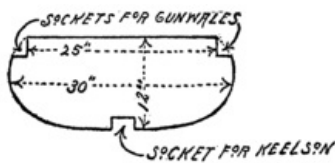

Fig. 124. Center Form.

Our sailing canoe proved such a good one that we decided to build a second. This was to be much lighter, for paddling only, and of the true Indian shape, with wide, bulging sides and raised stem and stern. The dimension of the forms used are given in Figs. 124 and 125. These forms, it will be observed, were notched to receive the keelson and gunwales. The keelson was formed of 1-inch spruce 3 inches wide and

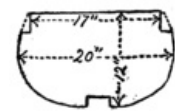

Fig. 125. Intermediate Form.

10 feet long. The stem and stern, which were both of the same shape, were cut from a 12-inch board to the form shown in Fig. 126, and were firmly secured to the keelson. This made the boat 12 feet long. The forms were then set in place on the keelson, one at the center and the others three feet each side. The gunwales were formed of 3/4-inch by 2-1/2-inch spruce, and the twelve rib bands used were of the size used in our first boat. As none of these forms was to remain in the boat, nails were driven very lightly into them, with heads projecting so that they could easily be withdrawn when it was time to remove the forms. The cross ribs were passed under the keelson inside of the rib bands and outside of the gunwales, as shown in Fig. 128. After

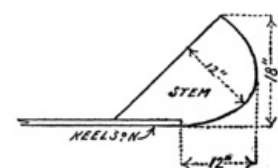

Fig. 126. The Stem Piece.

122

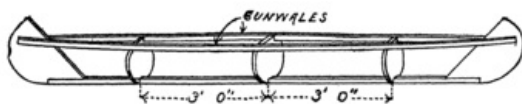

Fig. 127. Skeleton Frame of Canoe.

they were set in place and firmly secured with copper tacks, a band was nailed to the keelson to

form the keel. To produce the raised stem and stern, four wedge-shaped pieces were nailed to the tops of the gunwales, as indicated in Fig. 129. The forms were then removed and were replaced with cross sticks braced between the gunwales. The center cross stick was provided with two corner pieces, as shown in Fig. 130, adapted to fit under the gunwales and against the rib bands. The canvas was then applied in the manner described before, but was tacked to the upper edge of the gunwale instead of the outer side, and the tacks were covered by a half-round molding which extended around the entire boat. After the lacing was cut the edge of the canvas was secured to the under edges of the gunwales. The canoe was then completed by fastening on a 1-inch square keel and treating the boat with two coats of paint. The paddle was a duplicate of the one described in connection with the sailing canoe.

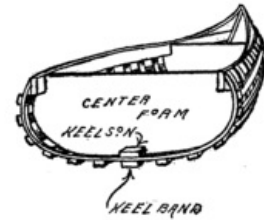

Fig. 128. Section at Center of Canoe.

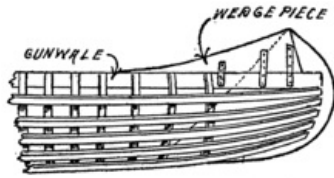

Fig. 129. Wedge Pieces at the Ends.

I remember that we eventually equipped our paddling canoe with a sail and a pair of lee boards, though no record of this fact appears in the chronicles of the society.



Fig. 130. The Cross Braces.

CHAPTER XI. HOUSE BUILDING.

One afternoon Fred, who had waded over to Lumberville after some provisions, came splashing back holding aloft a large square envelope. It was from Uncle Ed and contained a photograph of a group of Wichita Indians building a large grass lodge. In a brief explanatory letter Uncle Ed suggested that we build a similar hut on our Island.

The Grass Hut.

The grass lodge appealed to us as very picturesque, and we set to work immediately on its construction. We made our hut much smaller, however, only 12 feet in diameter, and 8 or 9 feet high. First we procured two dozen light poles between 10 and 12 feet long. These we set up about 18 inches apart in a circle like a stockade, the sticks being buried in the ground to a depth of 12 inches. At one side a space of 3 feet was allowed for a doorway. Inside the stockade we erected a working platform of planks supported on barrels, and standing on this we took two opposite poles, bent them inward and lashed their upper ends together. Then a second pair of opposite poles were similarly bent inward and tied, and so we proceeded until the entire stockade had been converted into a dome-shaped cage. Around these poles we laid lighter sticks, or bands, tying them at the points of intersection. At the doorway two posts were set firmly in the ground, projecting upward to a height of 4 feet. A lintel nailed across the top of the posts completed the door frame. Sticks were nailed to the lintel and to the side posts, extending to the main frame of the hut, to which they were tied. We were now ready to thatch our hut. Reddy and Dutchy went

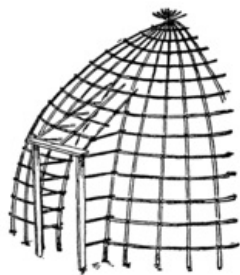

Fig. 132. Doorway of the Hut.



Fig. 131. Making the Frame of the Straw Hut.

over to Lumberville for several bales of straw. We tied the straw in bunches and applied it to the frame, copying, as best we could, the process illustrated in the photograph.

But for its location the hut would have proved a very serviceable habitation. In order to have a good, dry dwelling without laying down a board flooring, we had selected for its site the sandy shore at Point Lookout. This part of the island was not sheltered with trees, and the hot sun beat down on our hut so strongly that we found the quarters very uncomfortable indeed. It was this fact that led to the construction of a tree hut—a building that would be perfectly dry and yet shaded and cool. Bill had read of such houses in the Philippines and felt confident that we could build one. We couldn't decide at first where to locate our hut until Dutchy moved that we build it in the gnarled oak tree overlooking the "Goblins' Dancing Platform." Immediately the motion was seconded and unanimously carried.

The Goblins' Dancing Platform.

Just above the town of Lumberville there was a cliff which rose sheer 200 feet above the level of the river. So perpendicular was the cliff that a stone dropped from the overhanging ledge at the

top would fall straight down to the railroad track below without touching a twig in its course. Back of this broad ledge there was a very peculiar formation. A column of stone rose abruptly 40 feet higher and was topped with a large slab about 12 feet in diameter. This was known all over that region as the Goblins' Dancing Platform. The only possible way of gaining the summit of the column was by climbing a scraggly oak tree which grew on the high ground back of the pillar, crawling out on an overhanging limb, and then dropping down to the platform below. It was in this oak that we decided to build our house. It was a very inaccessible spot, and to reach it we had to make a wide detour around the back of the hill, and through the fields of a cranky farmer, who more than once threatened to fill us with bird shot for trespassing on his property. How were we to carry all our building materials up to this great height? One would think that the difficulties would be enough to discourage us, but not so with the S. S. I. E. E. of W. C. I. Nothing daunted us.

Dutchy Takes a Dare.

Our first task was to try some other approach to the top of the cliff. At one side of the overhanging ledge there was a fissure in the rocks which ran from the base of the pillar to the foot of the cliff. Down this zigzag crevice Dutchy had scrambled, one afternoon, on a dare. We were rather frightened when he started, because it was a very hazardous undertaking, and we watched him anxiously, peering over the edge of the precipice. By bracing his back against one of the walls of the rock, and digging his feet into the niches and chinks of the opposite wall, he safely made his way to a shelf about half-way down, where he paused to rest. From that point on the fissure widened out, and a steep, almost vertical incline, sparsely covered with vegetation, led to the railroad track below. I think he must have become rather frightened at his position, because he hesitated long before he resumed his downward course, and when he finally did make the attempt his foot slipped upon the moss-covered rocks and down he fell, scratching and clawing at every shrub within reach. Believing him to be killed, we rushed down the hill and around to the foot of the cliff. It probably took us about fifteen or twenty minutes, though it seemed ages before we came upon our venturesome comrade coolly trying to pin together a rent of inconvenient location and dimensions in his trousers.

"Say, Dutchy, are you killed?" cried Bill, breathlessly.

"Killed, nothing," he replied, with scorn. "I suppose you fellows think I had a fall. Well, I didn't."

"You didn't, eh? We saw you slip."

"Oh, go on. I came down that way on purpose. There was no use in picking my way down like a 'fraid cat, when I could just as well take a smooth and easy toboggan slide on the bushes all the way down."

Smooth and easy toboggan slide! Well, you should have seen the hillside. The course was well defined by the torn and uprooted shrubs and the pile of branches and vines at Dutchy's feet. Whether the hare-brained Dutchy really imagined he could glide easily down on the shrubbery, his frantic movements on the way certainly belied his story, and when, the next day, we proposed that he repeat the trick, somehow he didn't seem to be very enthusiastic on the subject.



Wichita Indians Building a Straw Hut.

A Path Up the Fissure.

It was up this fissure that we decided to haul materials for our tree hut. Our first task was to build steps and ladders in the steepest parts. We had no tool for cutting out niches in the rock, but wherever natural depressions were formed we wedged in sticks of wood between the side walls to serve as ladder rungs. If no such niches appeared for considerable height, we would stretch a rope ladder to the next fixed rung. In most places the natural formation of the rock was such as to afford sufficient footing.



Fig. 133. The Jacob's Ladder.

Rope Ladders.



Fig. 134. Rope Ladder.

The rope ladders were made of two parallel side straps, tightly stretched between the fixed sticks, and then at intervals of fifteen inches we inserted the ends of the ladder rung between the strands of the rope. Below and above each rung the rope was bound with cord. The rungs were notched at the ends to prevent them from slipping out.

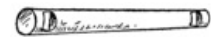

Fig. 135. A Ladder Rung.

After providing a means for scaling the cliff (we called it the Jacob's Ladder), we were still confronted with the problem how to cart our building materials to the top. It was a very hard task and you couldn't have hired us to do it under any other circumstances. First, Bill planned out on paper just how the house was to be built, and we cut all the pieces to the right size so as not to carry up any superfluous matter. When all was ready the boards and sticks were loaded on the scow, and ferried over to the cliff. Then we carried them on our backs, three or four at a time, up the slanting hillside to the first ledge. From there up, owing to the steepness of the ascent, we had to employ different tactics.



Fig. 136. The Derrick.

The Derrick.



Fig. 137. The Derrick in Use.

A derrick was constructed of two sticks 10 feet long, which were bolted together at the top, and secured about five feet apart at the bottom by a cross piece, as shown in Fig. 136. The derrick was then taken apart and with some difficulty hauled piecemeal up to the next ledge above. Here it was put together again. The fall and tackle used in our aerial railway was attached to the apex

of the derrick, and the latter was then erected with the legs set into depressions in the ledge and the upper ends slanting outward but kept from falling over the edge by a rope tied to one of the fixed rungs set in the fissure. With this derrick we hoisted up the boards in a few hauls. The job was a very ticklish one, but Bill used the greatest care to prevent accident. The derrick, rope and tackle were carefully tested before used, and as soon as the load was attached to the lower pulley block the two who did the loading were instructed to crawl back into the fissure so as to be out of danger in case anything gave way. At one time a stick which had been carelessly tied did fall, and it might have badly hurt some one had we not observed this precaution. When we had raised the material to the second ledge we transferred operations to the top ledge, and when the materials had been hauled up to this point we finally rigged up our fall and tackle in the old oak tree itself.

The Tree House.

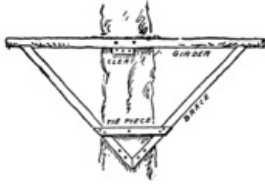

Fig. 138. Main Girder of the Tree House.

The tree had two large limbs which extended out at a wide angle from the main trunk. Across these two limbs, at about seven feet out, we laid our first girder, nailing it securely in place. Then to the main trunk we nailed the second girder on a level with the first. Diagonal braces were extended from the trunk to support the ends of this girder, and a tie piece was nailed to the braces, as shown in Fig. 138, to prevent them from spreading. The girders were rough sticks about 4 inches in diameter and 10 feet long. We cut flat faces on them at the

points where they were nailed to the tree, and then, to make them doubly secured, we nailed cleats, or blocks of wood, to the tree under them. The floor beams were then laid across and nailed to the girders. They were cut to a length of 10 feet so as to project beyond the outer girder to provide for a piazza overhanging the Goblins' Platform. Six floor beams were used, spaced 20 inches apart. All branches projecting up between the beams were then cut away and a flooring of slabs was laid on. To the main trunk six feet above the flooring, a stick or (to use the technical term), "wall plate," was nailed on, and its ends were supported by upright posts resting on the platform. Thirty inches from the outer end of the platform two more posts were erected eight feet high and secured by sticks nailed across from the other posts, and also by a second wall plate connecting their upper ends. Four more posts were erected, one between each pair of the corner posts, and then we were ready to enclose the framing.

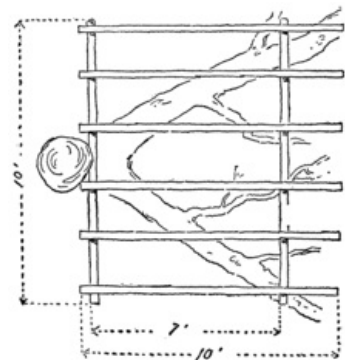

Fig 139. Top View of the Platform.



Fig. 140. The Frame of the House.

The sidewalls were first clapboarded, because we were afraid the roof would not hold us until the framing had been strengthened by nailing on the siding. Slab boards were used for this purpose. Beginning at the bottom, the boards were laid on, each lapping over the one below, as shown in Fig. 141, so as to shed water. In each side we cut a window opening and nailed on a window casing of the type shown in Fig. 142, which will be described in a moment. As soon as the clapboards were applied, we nailed on the rafters and then applied the roofing. The same principle was here used for shedding water. The lowest board was first laid on, and then the others were successively applied, each lapping over the one below.

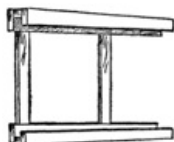

Fig. 142. The Window Casing.

The window casings we used each consisted of a frame about 15 inches square, but with the upper and lower pieces extending 12 inches beyond one of the side pieces. On these extended pieces a slideway was formed for the window sash by nailing on two strips of

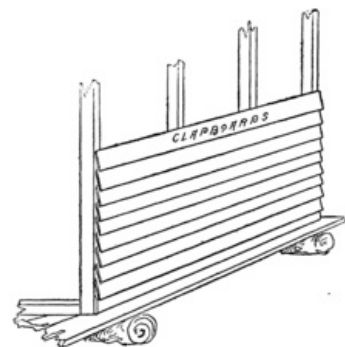

Fig. 141. Nailing on the Clapboards.

wood about 3/4 inch square and over them a pair of wider strips projecting inward, so as to overlap the edges of the sash. The window sash consisted of a frame 13-1/2

inches square, made of 3/4-inch square strips over which canvas was tightly stretched and tacked. A spool was nailed on at one side for a handle. These windows were closed only in rainy weather, to keep the water out.

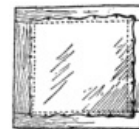

Fig. 143. The Window Sash.

Sliding Doors.

We had two doors; one at the back of the house, from which a ladder extended down to the ground, and another opening out onto the veranda, from which we dropped a ladder down to the Goblins' Dancing Platform. In order to save space we used sliding instead of swinging doors. The back door frame was 5-1/2 feet high and the front door frame 6 feet high. The doors were mounted on the outside of the building. The side posts of each frame were 2-1/2 feet apart, and the lintel and sill extended 3 feet beyond the side post at one side. The upper face of the lintel was planed down perfectly smooth, and its edges were tapered off to make a track for the rollers on the door. The rollers consisted of two spools, which turned on tenpenny nails driven into the top of the door. At the lower end two more spools were mounted, turning on nails driven in the bottom edge of the door. The rims of the spools extended slightly beyond the outer face of the door and rolled against the sill. To keep the water from leaking in at the top a slanting board was fastened above it, as shown in Fig. 144. The back door was similarly constructed. Our tree house was completed by a running balustrade around the veranda.



Fig. 144. Section of the Door and Frame.

It strangely happened that just after our tree house had been built we received a photograph from Uncle Ed of a Filipino tree house made of bamboo.



A Filipino Bamboo Tree House.

CHAPTER XII.

TROUBLE WITH THE TRAMPS.

We were a proud lot when the house was finally completed. From the veranda we had an excellent view up and down the river. We could see our camp on the island and keep watch of our goods. Late one afternoon Dutchy and I were lolling about on the Goblins' Platform, idly watching a hawk soaring above us. The rest of the boys had returned to the island in canoes an hour before and left the heavy scow for us to row back. It was drawing near supper time and we had about decided to start for home, when I chanced to see a scow up the river. It looked exactly like ours, and in it were two men, evidently drunk, from the way they carried on. A glance showed me that our scow was not at its moorings. How were we to reach the camp? One of the men had evidently seen us and was pointing us out to his companion. We rushed down the Jacob's Ladder, but by the time we reached the river bank they were in midstream and heading rapidly northward. Our shouts merely brought forth derisive laughter. We were certainly in a predicament. First we ran back up the cliff, and tried from there to gain the attention of the rest of the fellows. They

evidently saw us but couldn't make out what we wanted. Then we ran down to a point opposite the island and called to them. But the wind was against us and we couldn't make them hear, so we had to plunge in and wade across.

A Council of War.

Immediately we summoned a war council. Dutchy and Jack were chosen by lot to guard the camp, while the rest of us started in pursuit in canoes. By the time we got under way the sun had dropped back of the Pennsylvania hills and the shadows were climbing slowly up the Jacob's Ladder. Swiftly we paddled up-stream, keeping close to the western shore, where the water was very quiet. We didn't expect to go far, because there were rapids less than three miles up, and we were sure that no tramps would ever be ambitious enough to row a heavy scow against the swift current at that point. As we rounded a sharp bend in the river, we noticed a camp fire a few hundred feet further up, around which five or six men were lounging, and there, just below them, was our scow. What were four boys to do against six grown men? We were each armed with a club, and could have made a pretty good fight if necessary, but after a whispered consultation we decided it would be best to wait until dark, when we could creep up quietly and steal away unnoticed with our boat.

Vengeance.

It seemed as if darkness never would come. It was scarcely dusk when our patience gave out and we paddled up stealthily, hugging the shore. Bill gained the scow unnoticed, but just as he was about to push off he discerned the body of a man within. It was one of the tramps lying there in a drunken stupor. What was to be done? Every moment was precious. A yell from the fireside decided him. With a mighty push he launched the boat out into the current, while we threw him a line and towed the boat out to midstream. With a volley of curses the men sprang up and pelted us with stones. But they were poor shots, and we escaped without serious injury. Our prisoner, in the meantime, was snoring heavily in the scow undisturbed. We took him down-stream and then unceremoniously picked him up and dumped him overboard within a few feet of the shore. It was a rude awakening, and nearly frightened the wits out of the man. But it brought him to his senses, and in a moment we were dodging more stones, sent with such good aim that we had to lie flat in the bottoms of the boats until the current carried us out of reach.

A Double Surprise.

It was now quite dark, and we had some difficulty in groping our way back to camp. There was no moon and the stars were obscured by clouds. Our only course was to follow the shore line until we got around the bend, and then we steered for the beacon fire, which, by prearrangement, had been kindled on Point Lookout. But the spirit of mischief was in us. We thought we would have some fun with Dutchy. We could see him silhouetted against the blaze. Jim and I hung back in the canoes, while Reddy and Bill went on with the scow, splashing their oars and shouting and singing in disguised voices, like drunken men. Dutchy was evidently very much agitated. His "Hello, there! Boat ahoy!" was greeted with derisive yells.



Fig. 145. A Joke on Dutchy.

"Say, we'll lick the life out of you, the same as we did them other kids," shouted Reddy.

This was too much for Dutchy. He ran for all he was worth, yelling for Jack to come quick.

We had a merry laugh over the situation when suddenly the tables were turned. Something whizzed past Bill's ear; I was stung on the arm with a heavy nail; a large stone hit the scow; Reddy had his hat knocked off, and Fred upset his canoe trying to duck out of reach of the invisible missiles before we could make our assailants understand that we were friends and not the tramps. The joke was on us after all. We hadn't counted on Dutchy's accurate aim or Jack's skill with the crossbow.

Tramp-proof Boat Mooring.

Around the camp fire that night we discussed our adventures and made plans to prevent their recurrence. It was evident, for one thing, that we would have to moor our boats off shore in such a way that they would be out of reach of meddlesome persons, and yet could be drawn in toward

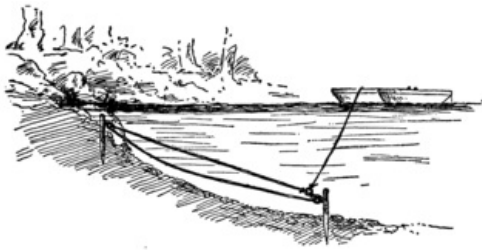

Fig. 146. A Tramp-proof Mooring.

shore by any one who knew how. This was the way we did it. A pair of galvanized iron ring bolts were procured on Jack's next trip to Lamington for provisions, also a light rope about forty feet long. The ring bolts were screwed into a pair of stout anchor stakes about two feet from their lower ends. The rope was passed through the rings and the ends were joined by tying them to a galvanized iron link. Then it was soaked for a while to shrink it before it was set in place. After the rope had shrunk sufficiently, the two stakes were driven into the bed of the river, one close to the bank and the other far

enough out to hold the rope belt clear of the bottom. Both stakes were sawed off under water, just above the ring bolts, so that they were hidden from sight. When we wanted to moor our boats we secured their anchor ropes or "painters" to the link. A large stepping stone marked the spot where the inner stake was driven, and standing on this stone we were able to reach down and haul in on the lower strap of the belt to draw the boat out a safe distance from shore, and then when we wanted to use our boat again we would haul in the upper strap to draw the boat in toward shore.

CHAPTER XIII.

WIGWAGGING AND HELIOGRAPHING.

Our tramp adventure was really quite a blessing to us, for it taught us the necessity of a good signaling system between the Goblins' Platform and the island and led to our learning how to wigwag, and later to the construction of a heliograph. Uncle Ed, when he read of our experience, sent us the U. S. Army "Manual of Signaling." Fred, the tailor of our camp, made us two white flags with red centers. Each flag was two feet square and was fastened to a light staff about five feet long. Then we got out the manual and practised sending signals, at first within shouting distance, until we got to be quite expert.

Wigwag Signals.

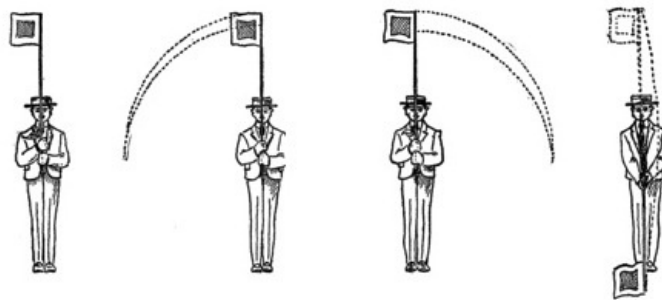

Fig. 147-150. Ready, First Movement, Second Movement, Third Movement.

There were only three different movements that could be made with flags, but in the book different combinations of these movements were given to represent each letter of the alphabet and the numbers from 1 to 0. All these movements were begun and ended by holding the flagstaff upright, directly in front of the body, as shown in Fig. 147. The first movement was to swing the flag down to the right and back (Fig. 148), the second to the left and back (Fig. 149), and the third forward and back (Fig. 150). The following table gives the different combinations used for various letters:

The Wigwag Alphabet.

A	22	J	1122	S	212
B	2112	K	2121	T	2
C	121	L	221	U	112
D	222	M	1221	V	1222
E	12	N	11	W	1121
F	2221	O	21	X	2122
G	2211	P	1212	Y	111
H	122	Q	1211	Z	2222
I	1	R	211	tion	1112

Numerals.

1	1111	4	2221	8	2111
---	------	---	------	---	------

2	2222	5	1122	7	1221
3	1112	6	2211	0	2112
		7	1222		

The numbers 1, 2 and 3 indicate respectively the first, second and third movements. For instance, A was represented by the combination 22, which means that the flag must be swept to the left and back twice. B is represented by the combination 2112, that is, a sweep to the left, two sweeps to the right and a final sweep to the left, as shown in Fig. 151. The end of a word was represented by a sweep forward and back; the end of a sentence by two sweeps forward and back, and the end of a message by three sweeps forward and back. It will be noticed that the same combinations are used for 2 and Z, 3 and *tion*, 4 and F, 5 and J, 6 and G, 7 and V, 9 and M, and 0 and B. The following abbreviations were given in the Manual:

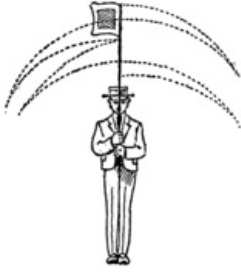

Fig. 151. The Signal for Letter "B."

Abbreviations.

a	after	n	not	ur	your
b	before	r	are	w	word
c	can	t	the	wi	with
h	have	u	you	y	yes

These abbreviations saved a lot of time, for when we wanted to signal the word *after* instead of spelling it out-22-2221-2-12-211-3-we used the signal for A-22-followed by 3 to signify that it was the end of the word. Before was represented by 2112-3, *your* by 111-211-3, etc. It took quite a little practice to learn the different combinations. Fred and Reddy soon became experts, and could flash the signals back and forth at a great rate.

Wigwagging at Night.

At night we used a torch in place of a flag. The torch consisted of a roll of dried birch bark tied with wire to the end of a staff. It was found necessary to place another torch on the ground directly in front of the signaler so as to fix a central point and enable one to determine whether the moving torch was swung to the left or right. A later improvement was to use three lanterns, one in each hand and one attached to the waist to fix the central position. It was quite an advantage to have a lantern in each hand, for it saved changing over from one to the other when a second movement followed a first or a first movement a second.

Fig. 152.
Wigwagging at Night.

The Heliograph.

The book that Uncle Ed sent us had in it a description of a heliograph, that is, an instrument for sending signals with flashes of sunlight. Although our wigwagging system was good enough for our requirements, yet we thought it would be more scientific to use the sun instrument, and besides, the latter could be used for signaling many miles.

The Single Mirror Instrument.

The first thing we did was to procure a small mirror about 4 inches square, mounted in a wooden frame. Then we got a pair of small square head bolts about 1/4 of an inch in diameter and 1 inch long, also two strips of brass 1/2 inch wide and 3 inches long. In the center of each brass strip we drilled a hole just large enough to admit the shank of one of the bolts, and then the strips were fastened with screws tight against opposite edges of the mirror frame, with the heads pressed against the frame and the shanks sticking out at each side, as shown in Fig. 153. These projecting shanks served as "trunnions" (that is, pivots) for the mirror to turn on when it was mounted in place. After the trunnions had been set in place we made a peep hole in the center of the mirror by cutting out a piece of the wooden back of the frame and scratching away the silver from the back of the glass. Only a very small hole was required, about 1/8 inch in diameter. Great care was taken to have the unsilvered spot exactly on a line with the trunnions and just half-way between them. This done, we took two sticks of 3/8-inch wood, 1 inch wide and 3-1/2 inches long. In the upper end of each stick a slot was cut 1/2 inch deep and 1/4 inch wide. Into these slots the trunnions of the mirror were placed, and then the nuts were screwed tightly on,

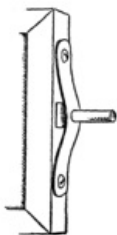

Fig. 153. Trunnion for Mirror.

clamping the sticks against the sides of the mirror. The sticks were now connected by nailing a 1/2-inch strip at the bottom, and braced by a couple of corner pieces. This formed a swiveled frame for the mirror, which was clamped to the base of the instrument by means of a bolt 1-1/2 inches long. The bolt passed through the bottom board of the frame, squarely under the peep hole of the mirror and through the baseboard of the instrument near one end. The baseboard was 2 inches wide, 10 inches long and 3/4 inch thick.

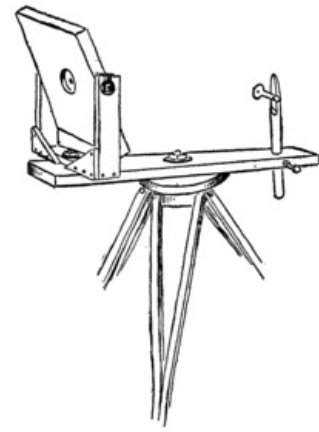

Fig. 154. The Single Mirror Instrument.

The Sight Rod.

At the end opposite to where the mirror frame was swiveled we mounted a sight rod, which was merely a round stick of wood 1/2 inch in diameter and about 8 inches long. We cut the stick from one of the rounds of an old broken chair. The upper end of the rod was whittled to a point and one side was flattened as shown in Fig. 155. Out of a piece of heavy white cardboard we cut a round disk about 1/4 inch in diameter, with a shank 1 inch long sticking out at one side. This was fastened with a single tack to the flattened end of the rod in such a position that the point lay exactly against the center of the disk. The disk could then be turned up or down, to cover or uncover the point of the rod, as desired. The rod was fitted snugly into a hole in the baseboard, and could be raised or lowered to any extent desired, but we



Fig. 155. The Sight Rod.

had to provide some sort of an arrangement for making it stay where it was put. A small hole was drilled from the edge of the baseboard through to the hole in which the rod was fitted. A square socket was chiseled out around the small hole to receive a nut. The nut was firmly wedged in and held in place by driving in nails along the edges. A bolt or machine screw was threaded through the nut, so that its inner end pressed against the sighting rod. By tightening this screw the rod could be secured at any height desired.



Fig. 156. Nut Set in Baseboard.

The instrument was mounted on a tripod similar to the one used for our surveying instrument. To this it was attached by means of a bolt, which passed through the center of the baseboard and the tripod head.

The Screen.

The screen, or shutter, of the heliograph was mounted on a separate tripod, so as to prevent shaking the mirror when it was operated. It was made something like a window shutter. We cut out two slats, each 2-1/2 inches wide and 6 inches long. They were made of hardwood 3/8 inch thick. The upper and lower edges were tapered down to a thickness of 3/16 inch. Light nails were driven into the slats at the ends, and the nail heads were then filed off so that the projecting ends formed trunnions for the slats to turn on. The slats were linked to a connecting rod with double point tacks. A small double point tack was driven into the upper edge of each slat about 1/2 inch from the right hand end. Then through each of these tacks we hooked a second double point tack and drove it into the rod. The tacks on the rod were placed just 2 inches apart. A substantial frame was then made of 3/4-inch stuff 1-1/2 inches wide. The frame was square, with an opening that measured 6 inches each way, into which the slats were fitted. Before nailing the frame together we drilled holes in the side pieces for the trunnions of the slats to turn in. These holes were just 1-3/4 inches apart. After the slats had been set in place, the frame was fastened together and then nailed to a baseboard, which was fastened by a bolt to the tripod. The shutter was operated by a key something like a telegraph key. It was made of a narrow stick of wood hinged at one end to the lower strip of the shutter frame, and a spool sawed in two was fastened to the other end to serve as a handle for the key. A string connected the key with the connecting rod. The slats were kept closed by a spring, which was fastened at one end to the connecting rod and at the other to the top of the frame. At first we used a rubber band for this purpose, but it soon wore out, so we then made a spiral spring out of stiff spring brass wire by wrapping it around a pencil. When the key was pressed down the slats would be turned open, as shown in Fig. 159; but as soon as the key was released the spring would pull them back again.

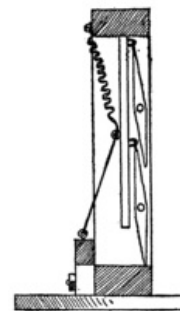

Fig. 157. Section through Shutter.

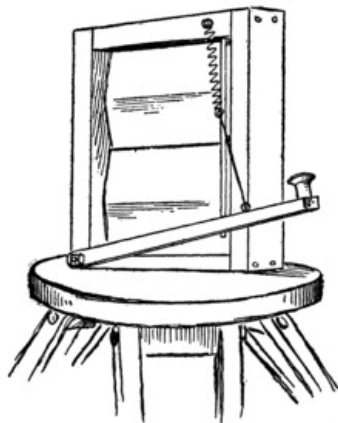

Fig. 158. General View of Screen.

Focusing the Instrument.



Fig. 159. The Heliograph in Operation.

We were now ready to commence operations with our instruments. The heliograph was set up on the ledge at the top of the cliff. First the disk was turned down, uncovering the point of the sighting rod. Then Bill sighted through the unsilvered spot in the mirror and shifted the rod up and down until the tip end came squarely in line with the door of our straw hut, where Jack was seated, notebook in hand, to take down our message. Reddy stood by him with his wigwag flag to answer back. When the instrument was properly sighted the shutter was set up directly in front of it and the sighting disk turned up to cover the point of the sighting rod. Then came the rather troublesome task of focusing the mirror. The mirror reflected a square panel of light, in the center of which there was a small shadow spot made by the unsilvered peep hole. The object was to get this shadow to fall on the center of the sighting disk. We knew that then the mirror would reflect the sunlight squarely on the straw hut. We found it quite easy to direct this shadow spot to the disk by holding a sheet of paper in front of the mirror six or eight inches away, and following up the spot on the paper until it reached the disk.

154

Heliograph Signaling.

When at last we succeeded in properly focusing the mirror Bill pressed the key down three times, sending three quick flashes to Jack as a signal that he was ready to begin. Reddy wigwagged back O. K., and then the first heliographic message was sent from the ledge to the island. It was a rather mixed-up message, and kept Jim and Reddy wigwagging back and forth very strenuously to straighten matters out. It was my duty to keep the mirror focused. As the sun moved across the sky the shadow spot would move off the disk, and I had to keep shifting the mirror to bring the spot back where it belonged. We used the International Telegraph Code, which we had been studying every evening for a week, but it was many weeks before we learned how to use it correctly, even slowly. The

155

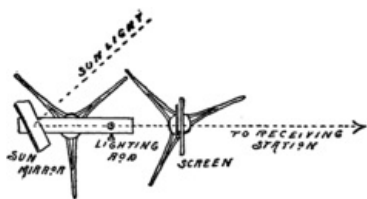

Fig. 160. Top View, showing position of Mirror and Shutter.

International Telegraph Code is as follows:

A	—	B	—	C	—	D	—	—	—
E	—	F	—	G	—	H	—	I	—
J	—	—	—	K	—	L	—	—	—
M	—	N	—	O	—	—	—	—	—
P	—	—	—	Q	—	R	—	—	—
S	—	T	—	U	—	V	—	W	—
X	—	—	—	Y	—	—	—	Z	—
1	—	—	—	2	—	—	—	—	—
3	—	—	—	4	—	5	—	—	—
6	—	—	—	7	—	8	—	—	—
9	—	—	—	0	—	—	—	—	—

The three short flashes Bill sent represented the letter S, which stood for the word "signal." A was formed by a short flash followed by a long flash; B by a long flash followed by three short ones, and so on. The key was held down three times as long for the long flash as for the short one. We found the best way of learning to send the signals properly was to count 1 for each short flash, and for each pause between parts of the letter, and 3 for each dash and for each pause

between letters. Between words we counted 6. Thus, for the letter A the key would be down when we counted 1, up when we counted 2, down while we counted 3, 4, 5, and up while we counted 6, 7, 8, for the pause after each letter. It was rather a confusing code, I admit, but in time we mastered it, all but Reddy and Fred, who never would learn, but instead used the wigwag code, letting a short flash stand for 1, a long flash for 2 and a double long flash for 3.

The Double Mirror Instrument.

Our heliographing instrument did excellent service sending flashes from the cliff to the island, but we couldn't make it work very well sending messages from the island to the cliff, because we had to face almost due north, and then the sun was nearly always at our backs and couldn't shine squarely on the mirror. This led to our building a double mirrored heliograph the following summer. To begin with, we built an instrument which was the exact duplicate of our first heliograph; then, in addition, to fit in the socket of the sighting rod, we rigged up a second mirror, which was mounted in exactly the same way as the first. The second mirror was called the station mirror, and differed from the other, or sun mirror, in having a small patch of white paper pasted at the center instead of a peep hole. When using this instrument, we set it up so that the station mirror faced the ledge, then by sighting through the hole in the sun mirror at the reflection in the station mirror we could see just what was in focus. The station mirror had to be moved until the patch at its center hid the ledge from view. After that the sun mirror was shifted until the shadow spot fell on the white patch of the station mirror. When once the station mirror was focused, it could be clamped tightly in place by screwing up the trunnion and swivel nuts. But the sun mirror had to be constantly shifted to keep the shadow on the patch. Another way of focusing the mirrors was to stand behind the instrument with the head close to the station mirror, shift the sun mirror until the entire station mirror was reflected in it, with the white patch squarely over the unsilvered spot; then still looking at the sun mirror, the station mirror was shifted until the reflection of the distant station was brought squarely in line with the unsilvered spot on the mirror. The station mirror was now firmly bolted and the sun mirror adjusted until the shadow spot fell on the paper patch.



Fig. 161. The Double Mirror Instrument.

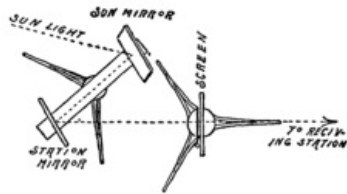

Fig. 162. Top View, showing position of the Two Mirrors and the Screen.

CHAPTER XIV.

ICE BOATS, SLEDGES AND TOBOGGANS.

As our vacation was drawing to a close, we began to make plans for the Christmas holidays. Our previous Christmas vacation had been so completely taken up with preparations for the trip to Willow Clump Island that we had had no time for the trip itself. We resolved this time to have everything ready beforehand, so that we could spend the entire two weeks in solid pleasure. Our skate sails and snow shoes were stored in the attic, ready for use. If we were to make a trip in the snow we would need a sledge, and then, too, we wanted to make an ice boat. It would hardly pay to build these on the island and then cart them home, so it was decided to break up camp a couple of weeks before school commenced.

Breaking Camp.

Consequently, on the first day of September we gathered up our belongings, corraled our chickens, packed our goods, and the next day started for home. Mr. Schreiner, in response to a letter from the secretary, came down with a large wagon in which the majority of the things were packed. The rest of our luggage was stowed in the scow and the canoes, and these were towed down the canal, as before. We reached home late in the afternoon, tired and hungry. It was a treat to sit at the table again and eat some of Mother's appetizing dishes. And say, wasn't that pie great, though! My, how ravenous we were! And then a soft, comfortable bed with spotless white sheets and pillow cases. How soundly we did sleep that night! You can just bet we were all glad enough to get back to civilization, though, of course, no one could have dragged out the confession from a single one of us.

The Ice Boat.

School commenced on the 20th of September that year, so we hadn't much time to spare. Work was begun immediately on the ice boat. Our first ice boat was rather a crude one. A 2 by 4 inch scantling 14 feet long was used for the backbone of the boat. The scantling was placed on edge, and to lighten it and improve its appearance it was tapered fore and aft from a point 4 feet from the bow end. The thickness of the ends of the backbone was but 2 inches, as shown in Fig. 163. To the under

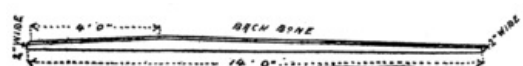

edge of the backbone, 5 feet from the forward end, a crosspiece was nailed. This crosspiece was a 1-inch

board 6 inches wide and 9 feet long. Braces were then run from the ends of the crosspiece to the forward and rear ends of the backbone, and at the rear end several boards nailed across the braces served as a seat for the boat.

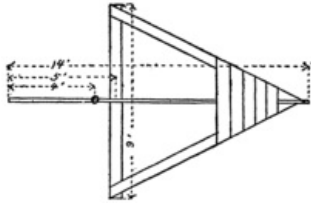

Fig. 164. Frame of the Ice Boat.

Our next task was to rig up the runners. For these we used skates, which were so arranged that we could remove them whenever we wanted to. Three blocks of wood were used for the runner shoes. Two of them were cut from a 2 by 4 scantling and measured a foot in length. The third block was only 1 inch thick, but was otherwise of the same dimensions. The skates were laid face downward on the blocks with the clamping levers open; then we marked the places where the clamping jaws touched the wood and drilled holes at these points. The forward end of each block was also tapered off to fit flat against the face of the skate. Then by inserting the jaws in the holes and closing the levers, the skate was clamped to the block, just as it would be to a shoe. The two 2-inch blocks were bolted to the ends of the crosspiece, but the third block needed further attention, as it was to be used for the rudder or steering runner.



Fig. 165. Runner Shoe.

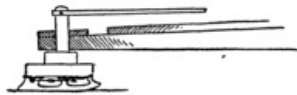

Fig. 166. The Rudder Shoe.

The rudder post was shaped from a block of hardwood 3 inches square and 10 inches long. Two inches from the lower end saw cuts were made in the side of the block to a depth of 3/4 inch. Then with a chisel the sides were split off, forming a large pin with a square shank 8 inches long. Next the corners of the shank were cut off, rounding it to a diameter of 1-1/2 inches. The runner block was fastened securely to the head of the rudder post with screws. A 1-1/2-inch hole was now drilled into the backbone at the stern end to



Fig. 167. The Tiller.

receive the rudder post. A tiller was next cut out of a 1-inch board to the shape shown in Fig. 167. A slot was cut in the end of the tiller, and the latter fitted snugly over the top of the post, where it was held in place by screws threaded in through the sides.

The mast of our boat was a pole 8 feet long, tapering from a diameter 2 inches at the base to 1-1/2 inches at the top. A step for the mast was cut from a 2 by 4 block 8 inches long. A 2-inch hole was drilled into the face of this block. We had no drill large enough to bore this hole, but accomplished the same result by drilling eight 1/2-inch holes inside of a 2-inch circle (Fig. 168), and then used a chisel to cut off the projecting pieces. The mast step was firmly bolted to the backbone at its thickest part, that is, just four feet from the forward end. The mast was braced with stay ropes stretched from the top to the forward end of the backbone and to the ends of the crosspiece. A 9-foot pole, tapering from 1-1/2 inches to 1 inch in diameter, was used for the boom of the mainsail, and for the gaff we used a 6-foot pole of the same diameter.



Fig. 168. Drilling the Mast Step.

The dimensions of the mainsail are given in Fig. 169. For mast hoops we used curtain rings. Five were attached to the sail along the luff, and one was fastened with a piece of leather to the end of the gaff. We used a different scheme for holding the boom to the mast. The forward end of the boom was flattened at the sides and a couple of cheek blocks were bolted on, forming jaws of the shape indicated in Fig. 170. The jaws were whittled out to fit nicely around the mast, and were kept from slipping off by a piece of rope passed around the mast and threaded through the ends of the cheek blocks. Half a dozen small pulley blocks were now procured, of the type used on awnings. A rope called the throat halyard was strung from the throat or forward end of the gaff through a pulley block near the top of the mast, and led down to the backbone, where it was "belayed," or wrapped around a cleat. The cleat, which was whittled out of a stick of wood, was made in the form indicated in Fig. 171. A short length of rope was strung through a pulley block and tied with some slack to the upper end and to the center of the gaff. This rope is called a "bridle," and to the pulley block on this "bridle" a rope was attached called the "peak halyard." The peak halyard was passed through a pulley block at the top of the mast, and belayed on a cleat at the side of the backbone. For the main sheet (that is, the rope used for guiding the mainsail) two pulley blocks were fastened to the backbone, one just in front of the seat and the other a few feet further forward, and two more were lashed to the boom, midway between these blocks. The sheet was fastened near the aft end of the backbone and then strung through the blocks in the order illustrated, the free end of the sheet being brought back to the seat, where a cleat was provided, to which it could be secured when desired.

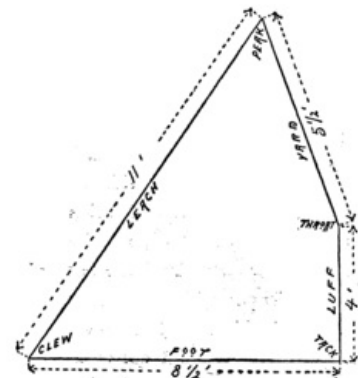

Fig. 169. The Mainsail.

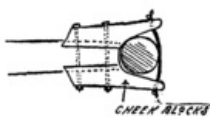

Fig. 170. Jaws of the Boom.

slipping off by a piece of rope passed around the mast and threaded through the ends of the cheek blocks. Half a dozen small pulley blocks were now procured, of the type used on awnings. A rope called the throat halyard was strung from the throat or forward end of the gaff through a pulley block near the top of the mast, and led down to the backbone, where it was "belayed," or wrapped around a cleat. The cleat, which was whittled out of a stick of wood, was made in the form indicated in Fig. 171. A short length of rope was strung through a pulley block and tied with some slack to the upper end and to the center of the gaff. This rope is called a "bridle," and to the pulley block on this "bridle" a rope was attached called the "peak halyard." The peak halyard was passed through a pulley block at the top of the mast, and belayed on a cleat at the side of the backbone. For the main sheet (that is, the rope used for guiding the mainsail) two pulley blocks were fastened to the backbone, one just in front of the seat and the other a few feet further forward, and two more were lashed to the boom, midway between these blocks. The sheet was fastened near the aft end of the backbone and then strung through the blocks in the order illustrated, the free end of the sheet being brought back to the seat, where a cleat was provided, to which it could be secured when desired.



Fig. 171. A Cleat.

The jib-sail was now cut out to the dimensions given in Fig. 172. The foot of the sail was lashed to a jib-boom 3 feet 4 inches long. The jib-boom was attached to the backbone at its fore end by means of a couple of screw eyes. The eye of one of these was pried open, linked through the



Fig. 172. The Jib-sail.

other and then closed again. One of the screw eyes was now screwed into the head of the jib-boom and the other was threaded into the end of the backbone. The upper corner or "head" of the jib was tied to a jib-halyard, which passed through a block at the top of the mast, and was secured on a cleat on the backbone. On the jib we used two sheets. They were attached to the end of the jib-boom and passed on opposite sides of the mast through blocks on the crosspiece to the stern of the boat, where separate cleats were provided for them.

This completed our ice boat, and a very pretty little boat she was. It was with great reluctance that we furled the sails, unstepped the mast, and stowed away the parts in our attic until old Jack Frost should wake up and furnish us with a field of smooth ice.

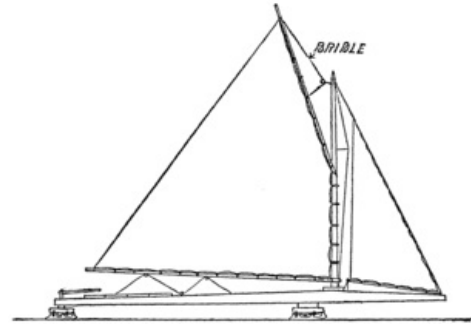

Fig. 173. The Ice Boat Completed.

The Sledge.

Our sledge was patterned after a picture of one used by Peary in one of his Arctic expeditions. First we got four strips of hickory 1 inch thick, 1-1/2 inches wide and 8 feet long for the runners and side rails. Beginning 18 inches from the ends, each stick was tapered gradually to a thickness of 1/2 an inch. Then we made eight spreaders or spacing blocks, each 1-1/2 inches thick, 2-1/2 inches wide and 11 inches long. In each end a notch 1/2 inch deep was cut to receive the runners and side rails. In the edge of each block, midway of its length, a slot 1 inch deep was cut to receive the cross sticks of the sledge. First we nailed the runners and rails to the blocks, fastening them with screws, spacing the blocks 16 inches from the ends, and 20 inches apart from center to center. Then we bent the ends of the rails and runners together, fastening them with bolts, as in Fig. 175. Four crosspieces, or floor beams, were cut out of a 1-inch board, each 2 inches wide and 30 inches long. These were fitted into the slots in the space blocks and secured with screws. A cross stick was also fastened between the rails and runners at the forward end. On the floor beams we nailed a flooring of 1/2-inch slats, 2 inches wide and 6 feet long. At the rear end these slats projected 8 inches beyond the last space block and over them a cross slat was nailed. A stick of hickory 4-1/2 feet long was soaked in hot water, as described on page 39, and was bent to an U-shape. The ends were then fitted over the first cross stick, and under the first floor

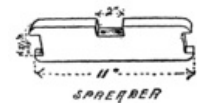

Fig. 174. A Spacing Block.

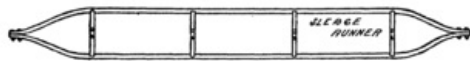

Fig. 175. The Runners and Rails Spaced Apart.

supports, and securely nailed in place. Another stick of hickory 6 feet long was similarly bent, and the ends slipped over the rear cross slats and fitted against the rear space blocks, in which position the stick was securely nailed.

It was our intention to shoe the runners with strips of brass, but these were not procurable in our village, and we had no time to go down to Millville. However, the village blacksmith came to our rescue and shod our sledge with sleigh runner iron.

We had planned to make two more devices for our winter sports—a toboggan and a peculiar looking contrivance called a "rennwolf," a picture of which Dutchy happened to unearth in one of his father's books. Unfortunately Bill and I had to return to school before either of these was completed. However, the work was entrusted to Reddy, who was quite handy with tools, and Jack, who was made secretary *pro tempore*, took notes on the work.

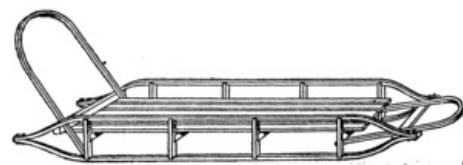

Fig. 176. The Sledge.

The Toboggan.

The toboggan was made of light flexible hickory boards, 1/4 of an inch thick, 6 inches wide and 8 feet long. Three of these boards were used, and they were fastened together with cross sticks or battens, about 3 inches wide and 1/2 an inch thick. There were six of these battens spaced about 15 inches apart, and secured to the floor boards with flathead screws introduced from the under side and countersunk so that the heads would not project below the bottom of the toboggan. At the forward end we screwed on a head piece of oak, 3/4 of an inch thick, 1-1/2 inches wide and 20 inches long. The head piece was fastened to the under side of the boards, so that when they were curved up into a hood it would lie on top. The ends of the head piece, which projected 1 inch each side of the boards, were notched to hold the rope, which was tied fast after the boards had been steamed. The boards were steamed by wrapping them in burlap for a distance of 2 feet from the forward end, and pouring boiling water over them, as was done with the snow shoes



Fig. 177. Tying Down the Head Piece of the Toboggan.

(page 39). Before bending the boards we had fixed screw eyes in the ends of each batten, except the forward one; a rope had been strung through these screw eyes and the ends were now tied to the head piece and drawn tight so as to bend the boards into a graceful curve. In this way the ropes were of service not only for

curving the front end into a hood, but also for side rails, to hold on by when shooting swiftly around curves.

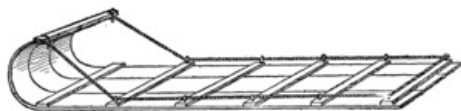

Fig. 178. The Toboggan.

The Rennwolf.

The runners of the rennwolf were made of hickory strips, 1 inch thick, 2 inches wide and 8 feet long. At their forward ends these strips were tapered down to a thickness of 1/2 an inch and curved upward. About 30 inches from the rear end of each runner an upright post was nailed. The post was 3 feet long and was braced by a diagonal brace 24 inches long, as shown in Fig. 179. A tie bar was nailed to the post about 6 or 8 inches from the bottom and connected with the forward curved end of the runner.

169

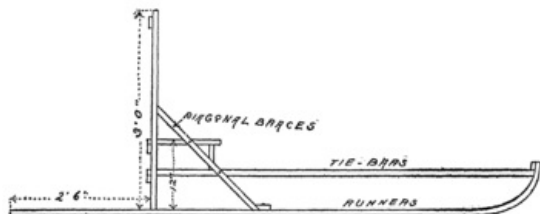

Fig. 179. Dimensions of Rennwolf.

The two runners were now placed parallel to each other about 18 inches apart, and connected by four cross bars, one at the forward end, and three on the upright posts, in about the positions illustrated. The upper cross bar was extended 6 inches beyond the posts at each side, and served as a handle for guiding the queer craft. An 18-inch square board was used for the seat of the rennwolf. It rested on the second cross-bar of the post about 12 inches from the runners, and the forward end was

supported on legs nailed to the tie bars. On each runner back of the posts a loop of leather was nailed, large enough to receive the toe of one shoe.

When using this odd sled one foot would rest on the runner with the toe in the strap, and by kicking out against the snow or ice with the other foot the rennwolf would be made to spin along at a rapid rate. Of course, when coasting both feet would rest on the runners and the sled was steered by an occasional side push at the right or left. Owing to the great length of the runners the rennwolf would easily ride over uneven surfaces and thin spots in the ice.

170

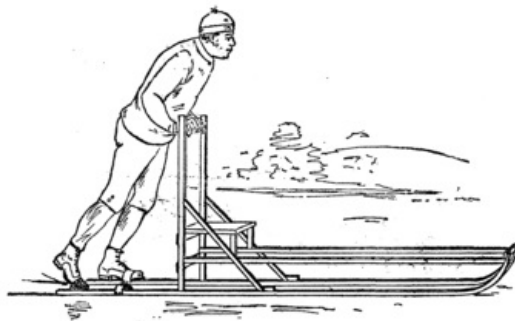

Fig. 180. The Rennwolf in Use.

Ice Creepers.



Fig. 181. The Ice Creeper.

In order to provide a better hold for the propelling foot, we fastened around the toe a strap of leather, through which a number of long tacks projected. Their sharp points would stick into the ice, and prevent the foot from slipping. The seat of the rennwolf was convenient for carrying a coat or any light luggage, and it was often used to give a friend a very exhilarating ride.

CHAPTER XV.

THE SUBTERRANEAN CLUB.

171

I am afraid we were not very glad to get back to school that fall. It seemed very hard to give up the sport we had been having, and our heads were brimful of new schemes which we could hardly wait to put into practice. But we soon learned that there are many things that could be done during recreation hours at school. We had intended building a cave on our island that summer, but our vacation came to an end before we got around to it. There seemed no reason why we shouldn't dig one in the woods at the back of the schoolhouse.

A Cave-in.

Bill had read somewhere that if you dig a cave under a tree the roots of the tree will support the

ground on top and make a natural and substantial roof. It sounded very reasonable, we thought; in fact, we never questioned the truth of the statement, because we had somehow gotten the notion that books were never wrong, and that whatever was set up in type must surely be so. But events proved that the man who wrote that book had never attempted to build a cave in the manner he described, at least not in the loose, sandy soil of south Jersey. A large spreading cedar was selected as the tree which should support the roof of our cave. It was situated on a mound at the edge of the woods. First a passageway, or ditch, was dug at the bottom, and then we begun tunneling in the side of the mound under the roots of the tree. For a while the ground above held, and our tunnel had reached a length of about four feet, when suddenly, without the slightest warning, the sandy soil gave way and we were engulfed. Bill, who was furthest within the cave, was almost entirely covered, while I was buried to the shoulders. A crowd of boys came to our assistance and dug us out. Poor Bill was almost smothered before they scooped the sand away from around his mouth and nose. The boys made slow work of it, having to dig with their hands and a couple of shingles, because the two spades we had were buried with us at the bottom of the cave.

Of course, this little episode gave us a scare, but it was only temporary. We swore every one to secrecy, so that Mr. Clark, the principal, wouldn't hear of the mishap and suppress any further cave building. It was obvious that the only roof we could depend on for our cave would be a wooden roof. If we had been at Willow Clump Island we would have gotten any amount of slabs from the lumber mills across the river.

One of our schoolmates, a day scholar, came to the rescue. His name was Chester Hill, a little bit of a chap, about the shortest for his age that I have ever seen. His name was so at variance to his size that we called him "Hillock," for short. Now Hillock lived on a farm about eight miles from school, and used to drive in every day on a farm wagon. He had helped us dig the cave under the cedar tree, and when he learned that we would need some lumber to build a safe cave, he told us that he had an uncle who owned a lumber mill on the Morris River, from whom he was sure we could get all the slabs we wanted. Of course, we were delighted, and laid our plans for an elaborate cave house. Hillock promised to be on hand on the following Saturday afternoon with his load of lumber.

Excavating for the Cave.

We immediately set out to make the necessary excavation. The side of a bushy knoll was chosen as a suitable site. First we carefully transplanted the bushes that grew in the square we had marked out for the cave, and cutting the sod into squares, piled it all neatly to one side. Then we shoveled away the top-soil and heaped it up for future use. After that we dug away the sandy subsoil. The cave proper we planned to make about 8 feet by 10 feet, with a passageway 2 feet wide and 6 feet long, leading in from a large bush at the base of the knoll. Our excavation was therefore somewhat T-shaped (see Fig. 182). At the deepest part we had to dig down about 10 feet.

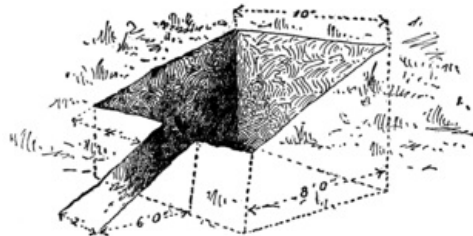

Fig. 182. Excavation for the Cave.

The digging was all done by Saturday, when Hillock pulled up with a big load of slabs. Slabs are a very unsatisfactory kind of wood for most purposes. Being the outside cut, they are usually very irregular and weak in spots. In many places they are almost clear bark. Of course, had our pocketbooks permitted, we would have used stout scantlings for the corner posts of our cave house and substantial boards for the walls, roof and flooring, but we had to be content with materials at hand. Eight of the best slabs were selected for our corner posts; four of them we cut to the length of 8 feet and the others to a length of 6 feet. The long slabs were set up at the rear of the cave, two at each corner, one flat against the rear wall, with its edge buried in the corner, and the other against the side wall, with its edge tight against the rear slab, as in Fig. 183. The same was done at the forward corners with the shorter slabs. A couple of slabs were now set up on each side of the passageway, and a corresponding pair against the rear wall. The upper and lower ends of the uprights were then connected with slabs, called stringpieces.

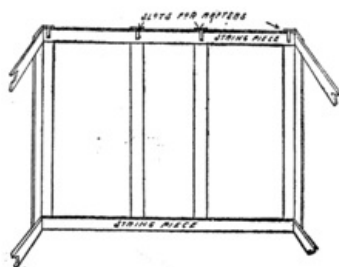

Fig. 183. Framework of the Cave.

The sides were now boarded up with upright slabs nailed to the stringpieces. An opening 3 feet 6 inches high was left in the forward wall for a passageway. Several slabs were now placed on the edge across the bottom of the cave, to serve as floor beams, upon which a flooring of slabs was laid. Next the rafters were set in place, one on each upright slab. Slots were cut in the ends of the uprights to receive the rafters, which were slabs placed on edge. As the forward uprights were 2 feet shorter than the

rear ones, the rafters were given a good slant, so that the roof would properly shed any water that might soak in through the ground above.

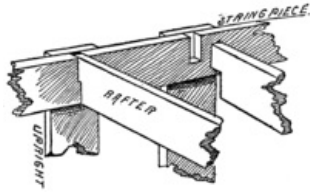

Fig. 185. Notching in the Rafters.

The roof was laid on the same way that we had made the roof of our tree house; that is, a slab was first nailed at the forward end of the rafters with its edge projecting far enough to make a good eave; then the

second slab was nailed on, with its edge overlapping the first, and a third with its edge overlapping the second, and so on with the rest. At the rear end of the roof a hole was cut, into which we fitted a piece of stovepipe. We didn't plan to have a fire in the house, but set the stovepipe in place to provide the necessary ventilation. As the pipe had an elbow in it, there was no danger of rain or dirt falling through it. The upper end of the stovepipe was concealed among some rocks at the top of the knoll.

A suitable flooring was now laid in the passageway, and the sides were boarded up to a height of 2 feet from the floor at the entrance to a height of 3 feet 6 inches at the inner end. A roof of slabs was nailed on, and then we were ready to cover our slab house with dirt.

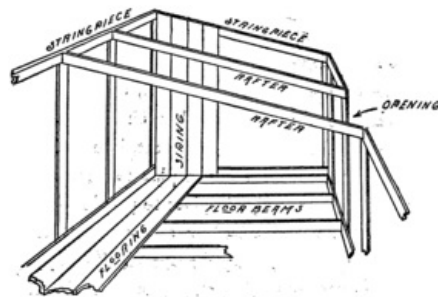

Fig. 184. The Siding and Flooring.

Covering the Cave.

We avoided piling on the dirt very deep, because there was danger of breaking in the roof with a heavy load. A thin layer of sand covered with the top-soil brought up the level to about that of the rest of the knoll. Then the sod was laid back in place and well watered, and the few bushes planted back in their original positions. Our sodding should have been done in the spring for best results. The frost soon killed the grass, and the bushes withered away. But a few cents' worth of grass seed was sowed in, and in time gave the knoll a very natural appearance. A bush at the bottom concealed the entrance of the cave, so that no one who was not in the secret would have suspected that beneath that innocent looking knoll were gathered the members of the "Big Bug Club."

The Big Bug Club.

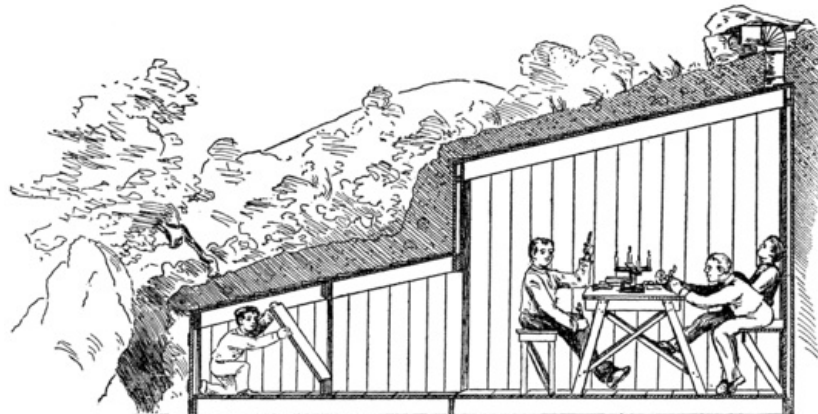

Fig. 186. A Section through the Completed Cave.

Of course, we had to organize a secret society, to occupy our subterranean dwelling. In that I fear we overstepped the rules of the school. Of course, Mr. Clark knew of our cave, in fact he visited us there once, lowering his dignity sufficiently to squeeze into the narrow passageway, and playing Bill a game of chess at our club table. He seemed quite pleased with our work, and complimented us very highly on the masterful way in which we had built the underground house. We told him that we had organized a club of the older fellows to play indoor games and have occasional spreads, but we did not tell him that most of our spreads were held at the dead of night, when there was no moon and the stars were hidden by clouds. At 10 o'clock each night the bell rang for us to turn out our lights, and after that the six members would each, in turn, keep a half-hour watch, that is, first one would sit up and try to keep awake for half an hour, after which he would waken the next fellow, who at the end of a half hour would rouse the third, and so on, until 1 o'clock, when the sixth watcher would wake up the entire club. Then we would all creep out the back window in the hall, onto the roof of the rear annex of the schoolhouse, and thence climb down a rope ladder to the ground.

Midnight Banquets.

I suppose we could have just as easily have tiptoed downstairs and out the back door, but it would have spoiled the romance of it all. The absolute stillness and the pitch-black darkness of the night were awe-inspiring. The roll of a pebble or the crack of a twig under foot would set us all atingle as we stole out to our cave house. Sometimes the night was so black that we could hardly find the entrance of the cave. Once inside, in the light of a few candles, the nervous tension was relieved, and we reveled in a banquet of cold victuals and dainties, purchased out of

the monthly club dues. Our meetings in the cave lasted scarcely half an hour. In fact, the meeting, and even the banquet, were mere incidentals. The main enjoyment consisted in stealing out to the cave and back again, always at the risk of getting caught. Usually when we got to bed again we would be too excited to fall asleep right away, and when we did finally drop off our sleep was so sound that several times the breakfast bell caught one or more of us still napping.

The Club Pin.



Fig. 187. The Club Pin.

The only other charm our secret club afforded was the wearing of a mysterious club pin. It was a silver beetle, with the letter G engraved on the head and the letter B on the body, while down the center of the back was the letter I (see Fig. 187). In public we called ourselves the G. I. B.'s, but it was only the initiated members who knew that these letters were to be read backward, and, with the beetle on which they were engraved, signified the "Big Bugs." Of course, we had some secret signs and signals, a secret hand grasp, a peculiar whistle as a warning to run, another meaning "lie still," and a third signifying "all is well."

The Combination Lock.

We found it necessary to close the entrance of our cave with a door fastened with a padlock, so as to keep meddlers out. The entire school had watched us build the cave house, and, of course, knew just where our entrance lay. Then, in addition to the outer door, we put in another one, half-way down the dark passageway. On this Bill rigged up a simple combination lock which would baffle any one who managed to pick the padlock. This inner door opened outward. It was hinged to the floor of the passageway, and swung up against a frame set in the passageway. At the top was a board whose lower edge lay flush with the edge of the door when it was closed. For the combination lock we used a couple of spools, each with one head cut off and the central hole plugged up with a stick of wood. In the floor and the top board of the frame, holes were drilled just large enough for the shanks of the spools to fit snugly in them. Next we made a trip to a hardware store for a file and a couple of large copper washers, about 1-1/4 inches in diameter. The washers were fastened to the inner ends of the spools after they had been pushed through the hole. The washer on the door came just to the edge of the door, while the other extended below the door frame and lapped under the door washer. Then in the edge of the washer on the frame a notch was filed, while in the other washer two notches were filed, so as to leave a tooth which fitted snugly into the notch of the first washer (see Figs. 188, 189). The door was

181



Fig. 188 The Notched Washers.

locked by turning both the washers until the notch and tooth came in line with each other, then pushing the tooth through the notch, and turning the washers so that the frame washer hooked over the door washer. Then the door could be opened only when the tooth and notch were brought in line.

On the head of each spool we pasted a disk of white cardboard, the edge of which was graduated, as in Fig. 190. Then we had a secret combination, say 11-19, which meant that when the spools were turned so that the number 11 on the door spool came in line with

Fig. 189. Washers Fastened on Spools.



182

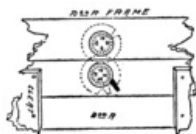

Fig. 190. The Combination Lock.

learn our combination he could not make use of it very long.

CHAPTER XVI. SCOOTERS.

183

"Hello, Dutchy! What in thunder have you got there?"

It was Bill who spoke. We were on our way home for the winter holidays, and had been held up at Millville by Reddy Schreiner, who had informed us that Dutchy was down by the river with the boat to give us a sail up to Lamington.

A vision of a fleet ice boat skimming up the river at express train speed swam before our eyes. But the next moment, as we turned the corner into River Street, we were surprised by the sight of our old scow just off the pier at anchor, and in open water. It was rigged up with a jib and mainsail, which were flapping idly in the wind. It had also been altered by decking over the top, with the exception of a small cockpit, evidently for the purpose of keeping out the water when

she heeled over under the wind. We were disappointed and quite annoyed at not finding the ice boat on hand; furthermore, our annoyance was considerably heightened by Dutchy's broad grin of evident delight at our discomfiture. "The river wasn't all frozen over," he explained, "and we couldn't bring the ice boat down, so we rigged up the scow and she came down splendidly."

A Sail in the Scow.

There was nothing to do but to jump in, though I, for one, would have taken the train in preference had there been one inside of two hours. Dutchy, however, seemed to be in a surprisingly good humor, and kept up a lively chatter about things that the club had made in our absence. The skis, which have already been described on page 42, had been built under Reddy's guidance, and they had already used them on Willard's Hill, coasting down like a streak and shooting way up into the air off a hump at the bottom. Then there was the toboggan slide down Randall's Hill, and way across the river on the ice.

Our Craft Strikes the Ice.

Dutchy talked so incessantly that we hadn't noticed the field of ice which we were nearing. Just at this point Bill turned around with an exclamation.

"Here, Dutchy, you crazy fellow, where are you going to? Hard to port, man-hard a port-or you will crash into the ice!"

But Dutchy only grinned nervously.

"I tell you, you will smash the boat!" Bill cried again, making a dive for the steering oar; but just then the boat struck the ice, and both Bill and I were thrown backward into the bottom of the boat. But the boat didn't smash.



A Sail on the Scooter Scow.

There was a momentary grinding and crunching noise, and, much to my surprise, I found that the old scow had lifted itself clean out of the water, and was skating right along on the ice. Then Dutchy could control himself no longer. He laughed, and laughed, as if he never would stop. He laughed until the steering oar dropped from his hands, and the old scow, with the head free, swung around and plunged off the ice ledge with a heavy splash into the open water again. Then Reddy, who was almost equally convulsed, came to his senses. "Now you've done it, Dutchy; you're a fine skipper, you are! How do you expect to get us back to shore again?" The steering oar was left behind us on the ice, and there we were drifting on the open water, with no rudder and no oar to bring us back.

The Scooter Scow.

The only thing we could do was to wait until the wind or current carried us to the ice or land. In the meantime Dutchy, who had suddenly sobered down when we took our water plunge, explained how he had rigged up the scow to travel both on ice and on water. He called the rig a sled boat, but the name by which such a rig is now known is a "scooter." It was Dutchy's idea primarily, but Reddy had engineered the work. Along the bottom of the scow two strips of hickory had been nailed to serve as runners. The hickory strips had been bent up at the forward end, as shown in Fig. 191. Each runner was shod with a strip of brass, fastened on with flathead screws, which were countersunk, so that the heads should not project below the brass. This virtually made a sledge out of the old scow, and didn't spoil it for use on the water.



Fig. 191. Scow with Runners nailed on.

A Sprit Sail.

A sprit sail and jib were rigged up. The dimensions of these sails, which were taken from a book in Mr. Van Syckel's library, are given in the illustrations. A sheet of heavy muslin was made to measure 7 feet square, as indicated by dotted lines in the drawing; then the corners were cut off along the full lines shown in the illustration. The edges were now hemmed all around, and the

lower edge of the sail was lashed to a boom, 7 feet 6 inches long. To the luff were attached a number of mast rings, which were slipped over a stout mast projecting about 5 feet 6 inches above the deck of the boat. The peak of the sail was held up by a spar called a sprit. The sprit was sharpened at each end, and the point at the upper end was inserted in a loop of heavy cord fastened to the peak of the sail, while the lower point of the sprit rested in the loop of a rope on the mast, called a "snotter." The snotter was a short piece of rope with a loop at each end. It was wrapped around the mast, as shown in the drawing, with one loop holding it in place, like a slip knot, and the other supporting the end of the sprit. A single halyard was used to raise this sail. It was attached to the boat and passed over a block in the mast. When raising the sail

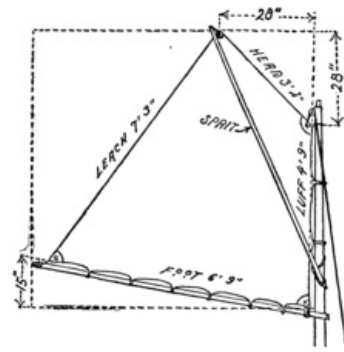

Fig. 192. Mainsail of Scooter Scow.

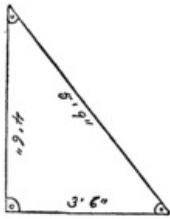

Fig. 194. Jib-sail of Scooter Scow.

it was first partly hoisted, then the sprit was hooked in the loop and the snotter, after which the throat halyard was drawn taut. Then the snotter was pulled up the mast as far as it would go, flattening out the sail. The jib-sail was made out of the large corner piece left when cutting the mainsail. The dimensions of the jib-sail are given in Fig. 194. It was such a small sail that no boom was used with it. In place of a rudder the steering oar had to be used. This was made of a rake handle with a large trowel blade fastened to the end of it.

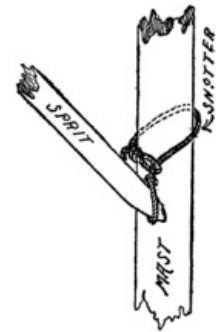

Fig. 193. The Snotter.

The sharp blade cut into the ice, and so steered the scow when it was running as an ice boat, and in the water the blade offered sufficient resistance to act as a rudder.

Scooter Sailing.

But to return to our sail home to Lamington, we were not out on the open water long before the current carried us back to the ice ledge. Reddy jumped off and soon returned with the steering oar; then we proceeded on our way homeward, now in the water and now on ice. Once or twice the scow was unable to climb out of the water, because she had not sufficient headway, and was clumsy and heavy with four boys aboard. Then we had to push off until we could get a sufficient start. It struck me that while Dutchy was quite clever to think of such a rig, yet it was very clumsy and capable of much improvement. Bill wasn't saying very much all this time, and I could see he was doing a lot of thinking. Evidently he was planning some improvement, but Bill was a very considerate fellow, and did not want to spoil Dutchy's pleasure just then by telling him how much better a scooter he might have built. It wasn't until after supper, when a meeting of the S. S. I. E. E. of W. C. I. was called, that Bill came out with his scheme.

A Meeting of the Society.

"Why not mount the sailing canoe on runners, instead of the scow? You would have a very light rig then, and it would sail like a streak."

"Mr. President," said Reddy, "your plan sounds first-rate, but how are you going to fasten runners onto the canoe?"

"I've thought all that out," replied Bill. "If we can only get hold of a pair of sleigh runners it won't take long to rig up the sled boat."

Dutchy, who had looked rather crestfallen at a suggestion of an improvement on his pet invention, now suddenly brightened up.

"I know where we can get the sleigh runners!" he exclaimed. "Dad has an old ramshackle sleigh in the barn that is just falling to pieces with dry rot. I'll ask him for it to-night."

"Do you think you can get it?" inquired Bill.

"I guess so," Dutchy answered, rather doubtfully. "But say, suppose we send a delegation to see him about it?"

An Interview with Mr. Van Syckel.

This was agreed upon, and in the morning, as soon as breakfast had been downed, the entire society marched in a body into Mr. Van Syckel's library. I was appointed spokesman, with Bill to back me, while the rest of the party were strung out behind, with Dutchy bringing up the rear. Mr. Van Syckel was not the man to take much interest in boys' work, but we happened to strike him at the right moment, and before our interview was over we had told him all our experiences of the summer before and all our plans for the future. Then we did a good turn for Dutchy, too. Mr. Van Syckel had always considered his boy a "know-nothing," and was very much surprised to find that he had invented the scooter scow. Why, he actually seemed proud of his son, much to Dutchy's embarrassment. After that there was no trouble about getting the sleigh runners, and Mr. Van Syckel forgot the objections he had offered at first.

The Scooter Canoe.

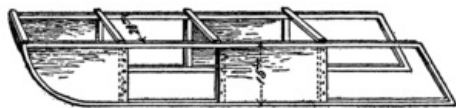

Fig. 195. Runners of Scooter Canoe.

Naturally we were very much elated at our success, and straightway made for the barn, where we began operations on the scoter canoe. The sleigh was an old-fashioned affair, with rather broad wooden runners. First we removed the body of the sleigh, and then the runners were cut down to a height of about 15 inches. We spaced them apart about 28 inches, and connected them with four crosspieces at the top. The runners were now placed over our larger canoe, with forward ends about on a line with the mast, and the crosspieces were fastened with screws to the gunwales. As an additional security, a pair of crosspieces were now run under the canoe at each end and fastened with screws to the keel. At the bow the keel was shod with a strip of brass. The rudder was taken off the boat, and an oar lock was fastened to the stern to hold the steering oar. In place of lee boards we nailed a couple of thin boards over each runner, as shown in the drawing. We were in a hurry to finish this, as our vacation was short, so we used on the scoter canoe the sails that we had made for our ice boat. This required a bowsprit, but as we had little time to spare we used the jib-boom of the ice boat, nailing it to the deck beam of the canoe. We decided that the jib-sail could be used without a boom, as we had done with the scow. The mast was braced by stays attached to the ends of the runners and bowsprit. This spread of canvas was far greater than that originally provided for sailing the canoe, but the heavy runners on each side helped to keep the boat on even keel, and then to further balance the sail a board was nailed across the aft end of the boat. This overhung the runners about 18 inches each side, and in a strong wind we could sit out on the windward end of this board, thus preventing the scoter from heeling over too far.

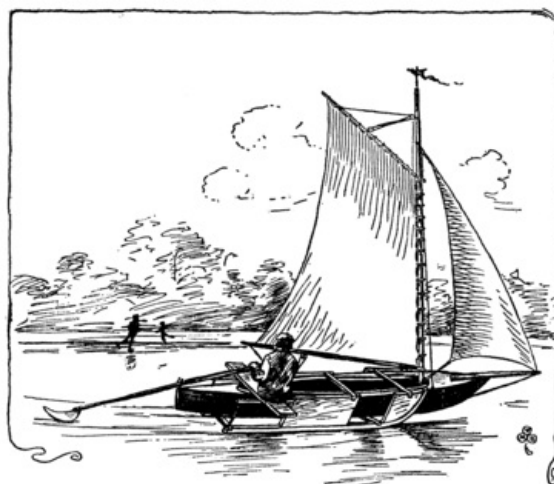

Fig. 196. The Scooter Canoe.

CHAPTER XVII. AN ARCTIC EXPEDITION.

As soon as our scoter canoe was completed we prepared for the long-planned winter expedition to Willow Clump Island. The weather conditions were ideal. We had had ten days of steady cold weather, which had followed a heavy fall of snow, so that we could tramp up the island on snow shoes, or we could use our scoter canoe and scoter scow on the river. It was out of the question to use our skate sails or the ice boat on the river, and the canal would be serviceable only in case the wind should blow from a southerly quarter. But we stowed them on the sledge for use on Lake Placid.

On the Tuesday morning following Christmas we made the start. Bill in the scoter canoe and Dutchy in the scoter scow sailed up the river, and the rest of us, on snow shoes, took the tow path of the canal, hauling the sledge along. We carried provisions for a week and a good supply of blankets. The island was reached without mishap, except that Dutchy had to be helped several times in dragging the heavy scow around the rapids. Bill reached the island long before we did, and after unloading the canoe came racing back under a stiff breeze for a second load. Then he took his turn at hauling the sledge, while Reddy sailed the reloaded scoter canoe up to the island.

Willow Clump Island in Winter.

We brought no tent with us, as we expected to take up our quarters in the straw hut. When we reached the hut we hardly recognized it. It was almost completely covered with snow and looked like an Eskimo house. The snow had drifted well up over the north side, completely closing the entrance. We had to set to work at once with a shovel and open up a passageway, and then we had to shovel out a large pile of snow that had drifted into the hut from the open doorway.

Kindling a Camp Fire.

In the meantime Jack scoured the island for some dry wood. In this he was not very successful, because everything was covered with snow, and when he tried to kindle a fire in the open space in front of our hut he found the task an exceedingly difficult one. Unfortunately we forgot to bring the oil stove with us, and the prospect of something warm to eat was exceedingly remote. We hadn't yet learned the trick of building a camp fire in wet weather. After exhausting our stock of paper Fred and I started over to Lumberville for several newspapers and a can of kerosene. We went to old Jim Halliday's, who had befriended us on one or two occasions the previous summer, and made known to him our troubles.

"What! A can of oil to build yer fire with? Well, ye won't git it from me. I know a man as got blowed up apourin' oil on a fire. Why, shucks, boys, you don't need no oil ner paper nuther on that there island. Its chuck-full of silver birch trees, and there ain't no better kindlin' than birch bark."

Birch bark! Why, yes, why hadn't we thought of that? We had used it for torches the summer before and knew how nicely it burned. So back we skated to camp, and then, peeling off a large quantity of bark from the birch trees around us, we soon had a rousing big fire in front of the hut.

The Outdoor Fireplace.

But there were more things to be learned about open fires. In our summer outing Jack had done most of his cooking on a kerosene stove, and he soon found that it was a very different matter to cook over an unsheltered fire. The heat was constantly carried hither and thither by the gusts of wind, so that he could scarcely warm up his saucepans. We had to content ourselves with cold victuals for the first meal, but before the next meal time came around we had learned a little more about fire building. Two large logs were placed about 10 inches apart, and the space between them was filled in with pieces of bark and small twigs and sticks. The back of the fireplace was closed with stones. One touch of a match was enough to kindle the fire, and in a moment it blazed up beautifully. The logs at the sides and the stones at the back prevented the wind from scattering the flames in all directions, and a steady draft poured through the open end of the fireplace and up through the heart of the fire. The side logs were so close together that our cooking utensils could be supported directly on them.



Fig. 197. An Outdoor Cooking Fire.

A Stone-paved Fireplace.

The following summer we continued our open fireplace experiments. Instead of using logs we drove stakes into the ground, forming a small circular stockade about 2 feet high and 3 feet in diameter. A paving of small stones covered the floor of the fireplace, and a lining of stones was laid against the wall. The stakes were driven in on a slant, as illustrated in Fig. 198, so as to better support the stone lining. A break in the stockade at one side let in the necessary draft. Two of the stakes on opposite sides of the fire were made extra long, and were crotched at their upper ends. They served to support the cross stick from which our kettles were hung. This form of fireplace was more satisfactory for baking than the one in which logs were used for the side walls, because the stone lining retained the heat much longer. To bake biscuit, a pot of beans, or the like, the ashes would be drawn away from the stone paving and the pot placed directly on the hot stones, after which it was covered with hot embers and ashes.



Fig. 198. A Stone-paved Fireplace.

A Cold Night in the Hut.

But to return to our experiences on the island. We found it very cold on the first night in the hut. We were afraid to build a fire inside lest the straw thatchings would catch fire, and so we huddled together in the corner, rolled up tightly in our blankets. But it was cold, nevertheless. We had no door to close the opening into the hut, and instead had piled up branches of cedar and hemlock against the doorway. But a bitterly cold northwest wind was blowing down the river, and we couldn't keep warm, no matter what we did. Most of the boys were ready to go right home, but we stuck it out until the morning, and then after we had toasted ourselves before a blazing bright fire, and had eaten a hot breakfast, we forgot much of the discomfort of the night and were ready for more "fun." We thought we would spend the next night in our tree house, and so, right after breakfast, we packed up our blankets and some provisions and started for the Jacob's Ladder.

Mountain Climbing.

Each fellow was provided with a pair of ice creepers of the same sort as we had used in connection with the rennwolf (see page 170). In addition to this each boy was provided with a home-made alpine stock, consisting of a stout wooden stick in the end of which a large nail was driven and the head filed off. Thus equipped we came to the foot of the cliff, and much to our delight found it one mass of ice from top to bottom. Now was our chance to try some Swiss mountain climbing. Bill took the lead, with an old hatchet in his hand, to hack out any necessary footholds in the ice wall, and the rest of us strung out behind him tied to a long rope, each boy

about 10 or 12 feet from the one ahead. Bill cautioned us to keep our distance, holding the rope taut in one hand, so that if a fellow stumbled he could be kept from falling either by the one in front or by the one behind.

"Besides," he said, "if the rope drags on the ice, it is liable to be cut or worn so that it will break when any strain was put on it."

Now, one would think from all these precautions that we were launched on a perilous expedition. That was the impression we were trying to make on ourselves, though, as a matter of fact, any one of us could have climbed the cliff unaided and without any ice implements if he had used ordinary care not to slip on the ice-clad ladder rounds or the snow-covered ledges.

199



Fig. 199. Winter Expedition to the Goblins' Platform.

A Poor Shelter.

The climb was without mishap and we reached our tree house, only to find it so badly racked by storm and weather that it was clearly out of the question to attempt to spend the night there. The wind howled around the house and whistled through dozens of cracks and chinks that had opened in the walls. All that we could do, therefore, was to turn back to the island and make the best of our straw hut again. On the way, however, we stopped at Lumberville for some straw to be used for bedding. The afternoon was spent sailing around on Lake Placid and the large smooth stretch above the island.

200

A Costly Camp Fire.

After supper Bill and Reddy went into the hut to arrange the straw bedding, while the rest of us gathered wood for a huge bonfire in front of the hut. The wind was blowing right down the river and we expected it to carry the warmth of the fire into the hut. The fire was built some distance in front of the doorway, so as to prevent the hut from catching fire. But we had evidently miscalculated the strength of the wind, for no sooner was the fire fairly started than a shower of flaming brands was blown right into the hut. In a moment the straw blazed up, cutting off all escape for Bill and Reddy. Fortunately the framing was not strong and the frost had loosened up the foundations, so that a few frantic kicks opened an exit in the rear of the hut just in time to save our comrades from cremation. Once it was fairly started we were powerless to put out the blaze until the hut was ruined. The snow that covered the walls checked the fire somewhat, but the thatching burned from the inside, melting the snow and dropping it suddenly into the flaming straw bedding on the floor. As we sat in a gloomy ring about the camp fire, watching the tongues of flame play about the charred ribs of our hut, we had reason to be thankful that the wind had played its pranks before we turned in for the night. What a risk we had run of being all burned to death! It made me shudder to think of it. Well, our hut was burned. What next? That was the question put before the society.

201



Bill Gets Tangled up with His Skis.



Warming the Lunch on a Cold Day.

"Might build a snow hut," suggested Dutchy.

"Now, be sensible," answered Reddy. "We can't build a snow hut in five minutes."

"The best plan," I volunteered, "would be to go over to Jim Halliday's and ask him to let us sleep in his barn."

Immediately the suggestion was acted upon.

A Friend in Time of Trouble.

Old Jim Halliday greeted us very gruffly. He said he wouldn't have us in his barn. "You'll be amussin' up the hay so't wouldn't be fit fer the horses to eat. Any boy that is fool enough to build a fire on a straw bed ought to go right home to his mother, and he hadn't oughter be trusted with matches, nuther. He might get his fingers burned."

But I caught a twinkle in the old man's eyes and wasn't surprised to have him end his lecture by taking us into the kitchen and seating us around an old-fashioned log fire while "Marthy," his daughter, made us some hot coffee to take the chill out of our bones. We didn't sleep in the barn that night. The Hallidays had only one spare bed, hardly enough for six boys, and the old man didn't want to be partial to any two of us, but his daughter solved the difficulty by dragging down two large feather mattresses and laying them on the kitchen floor in front of the hearth.

Before bidding us "good night," Mr. Halliday put on his sternest expression and bade Marthy clear out all the matches from the room.

"Jest as like as not they'll set fire to the house," he growled. "I expect this is my last night on airth." And then, with a solemn warning not to hang our clothes on the flames, and to "keep them feather beds offen the embers," he left us to a comfortable night's rest.

In the morning, after we had disposed of all the hot griddle cakes we could eat, and had sincerely thanked our host and hostess for their hospitality, we wended our way back to the island, silently packed up our goods and started home for Lamington.

"Well, this isn't going to happen again," was Bill's comment. "Next year we'll have a log cabin on the island."



Fast Asleep in a Sleeping Bag.

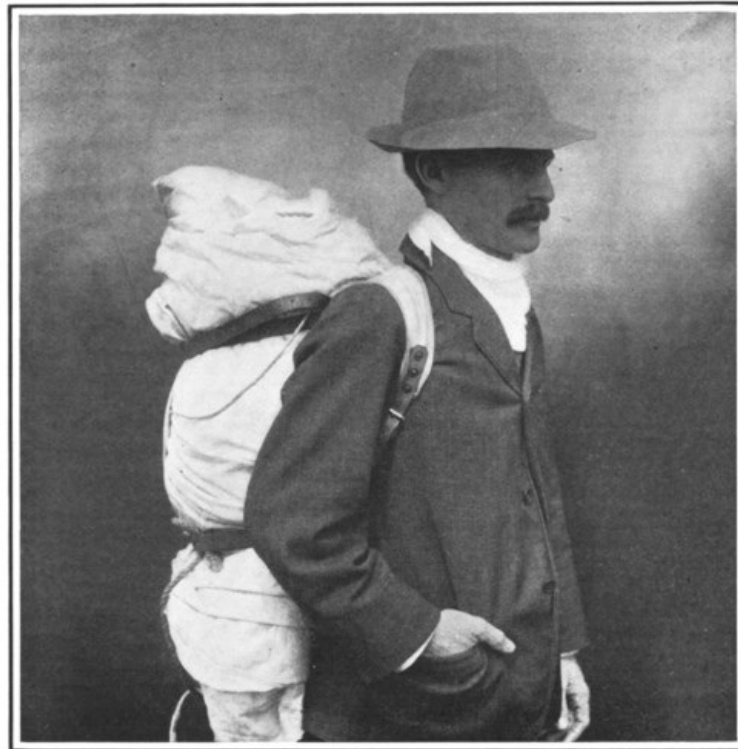

How the Pack Harness was Worn.

CHAPTER XVIII. TRAMPING OUTFITS.

203

Our winter expedition to Willow Clump Island filled us with a wholesome respect for Arctic explorers. If we could find it so uncomfortable with the thermometer only at 10 degrees above zero, what would it be to endure a temperature of 40, 50 or even 60 degrees below zero? We were interested to learn how they managed to stand it. This led to a study of the subject in Mr. Van Syckel's library.

Sleeping Bags.

In one of the books Dutchy came across the description of a sleeping bag. It was made of reindeer's skin sewed into a large bag with the fur side turned in. This bag was large enough to hold three or four sleepers, and each man was covered with a pair of woolen bags, one bag slipped inside the other. The woolen bags were made of blankets sewed together and provided with flaps at the upper ends to cover the head of the sleeper.

Of course, we had to make a sleeping bag, too. The innermost bag was made of an old quilt and the next one of a blanket that we were fortunate enough to get hold of. But when it came to the reindeer skin we were balked, until we happened to run across a piece of rubber sheeting at the village store. This was a lucky find, for I doubt if one country store in a hundred carries such stock. The piece was just large enough to cover the blanket bag and allow for an ample flap to cover the head. To be sure, this furnished a shelter for only one person, and there were six in the society. It was clear that the treasury could not afford the expense of six sleeping bags; but as such a device would be useful only under very unusual circumstances we decided that two sleeping bags would be all the society would need. We had been rather curious to explore the country back of the hills on the Pennsylvania side of the river, and with some light provisions and

204

these sleeping bags strapped to the back a couple of boys could make quite an extended tour, unmindful of weather conditions. On real hot nights a fellow could get into the quilt bag and sleep on the blanket and waterproof bag. In cold weather the combination of all three bags provided sufficient warmth. The rubber bag would protect the sleeper from any moisture in the ground, and would also keep him thoroughly dry, even in a pouring rain.

Bill's "Mummy Case."

Our second sleeping bag was Bill's own design, and was, in many respects, an improvement on the first, though it looked ridiculously like an Egyptian mummy case. The inner bags were just like those of the first sleeping bag, but as there was no more rubber sheeting in town we had to make the outer bag of enameled cloth, such as is used for carriage curtains. Out of this cloth Bill cut a piece of the shape shown in Fig. 200 to serve as bottom, sides and ends of the sleeping bag. The bag was sewed wrong side out; that is, the piece was laid with enameled side up, and then the corners were sewed together after painting the seams with white lead.

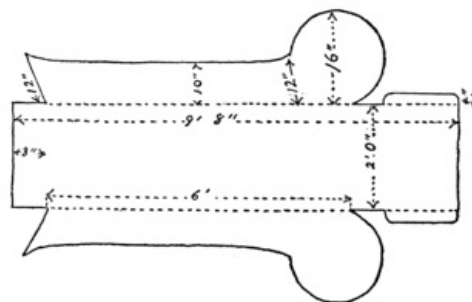

Fig. 200. Bottom Piece of Sleeping Bag.

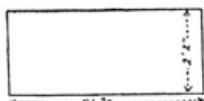

Fig. 201. Top Piece of Sleeping Bag.

Then a top piece was cut out, of the size indicated in Fig. 201. The edges were hemmed over a piece of rope, which thus formed a corded edge. Now, with the enameled side of the cover piece turned inward, its edges were sewed to the edges of the first piece. The bag was now turned inside out, so that the enameled surface lay on the outside and the seams turned inward. The corded edge on the cover piece lapped over the sides, forming a watershed.



Fig. 203. The Mummy Case.

It was Bill's idea to rig up the flap in such a manner that it would not lie against the face, so that the sleeper could have plenty of fresh air, even in rainy weather. This required the use of two headboards, of the form shown in Fig. 202. The headboards were connected at the bottom

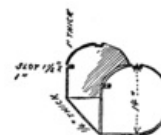

Fig. 202. Headboards.

by a thin board, and to this framework the sides of the bag were nailed. To the end flap several cleats were nailed, adapted to fit into notches cut in the headboards. The cleat at the end of the flap was laid on edge, as shown, and fitted into deep notches in the headboards just above the edge of the cover piece. This held the flap securely, preventing it from flying open in a heavy wind. At the same time the small space between the flap and the cover piece allowed for an ample supply of fresh air. When using this sleeping bag, if there was any indication of a shower, we took care to have the head pointed to windward so as to prevent entrance of rain through this air space.



Fig. 204. Sleeping Bag in Use.

The "A" Tent.



Fig. 205. The "A" Tent.

In connection with the sleeping bags it may be well to describe here a curious shelter Dutchy and I came across in one of our tramps. It was just about dusk one day when we discovered a temporary camp at which a couple of men were preparing dinner. They informed us that they were naturalists on a two weeks' outing. At their invitation we joined camp with them. They had a small "A" tent of balloon silk, under which they kept their provisions. The tent had no ridge pole, but was supported instead by a rope stretched between two trees (see Fig. 205).

A Camp Chair.

The camp was also furnished with an easy canvas chair, made by driving a couple of short posts in the ground for front legs and a pair of longer ones for the back. A piece of canvas was hung over these posts, forming both seat and back. The posts were driven into the ground on a slant, as illustrated in Fig. 206, and the canvas was formed with pockets at the corners which were

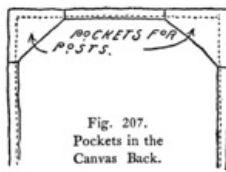

Fig. 207. Pockets in the Canvas Back.

hooked over these posts. This made a very comfortable chair, though, of course, it was fixed to one spot. When the men moved camp they would carry with them only the canvas piece, and at the next stopping place new posts were chopped and used for legs.



Fig. 206. The Camp Chair.



Waiting for a Bite.



Temporary Shelter under an "A" Tent.

The Camp Bed.

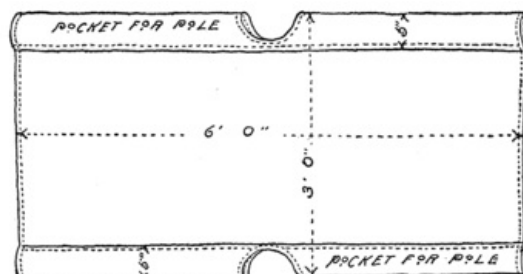

Fig. 208. Canvas Bed.

But what interested us most was the form of bed they had. This, like the chair, consisted of a piece of canvas arranged to be supported on posts cut from the woods in the neighborhood of the camp. The canvas piece was 3 feet wide and 6 feet long, with a wide hem at each side, forming pockets through which poles were passed, as in a stretcher. The ends of the poles were supported on posts driven into the ground. The poles were also propped up at the center, as shown, the pockets being cut away and bound, so as not to permit any wear on the canvas. To prevent the posts from leaning inward under the weight of the sleeper, they were braced apart by cross sticks.

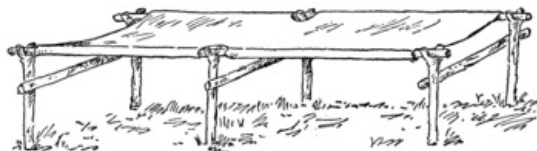

Fig. 209. Bed Set up on Posts.

The Camp Bed in a Shower.

As a precaution against rain, a tall post was set up at the head and another at the foot of the bed, and a rope was stretched over the posts with the ends fastened to stakes driven into the ground. Over this rope a rubber "poncho" was laid to keep off the rain. A "poncho," by the way, is a blanket of rubber cloth about 4-1/2 feet wide and 6 feet long, in the center of which is a slit through which you can put your head; then the rubber cloth falls over you like a cape, as in Fig. 210, and makes a perfect protection against rain. The ponchos these men had were not quite long enough to cover the whole bed, so they fastened umbrellas to the head posts, as shown in Fig. 212. During a shower

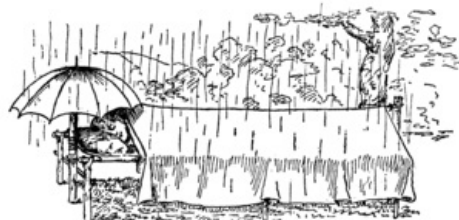

Fig. 211. Camp Bed in the Rain.

in the woods the rain comes straight down in large drops, caused by the water collecting on the leaves. To prevent these large drops from splashing through the umbrellas, they laid pieces of cloth over the umbrellas, which served, like the fly of a tent, to check the fall of rain drops.



Fig. 210. A Poncho.



Fig. 212. Umbrella with Fly.

A Nightmare.

I slept in the mummy case that night and Dutchy in the first sleeping bag. It must have been about midnight when I was awakened by a most unearthly yell. It sent the cold chills running up and down my back. A second scream brought me into action, and I struggled to throw back the head flap, which had become caught. It seemed an age before I could open it and wriggle out of the bag. Dutchy was sitting up in bed with a look of horror on his face, and his whole body was in a tremor of fear. One of the men dashed a glass of water in his face, which brought him back to his senses. It was only a nightmare, we found. Dutchy dreamed he had been injured in a railway accident and had been taken for dead to the morgue. He tried to let them know that he was alive, but couldn't utter a sound, until finally he burst out with the yells that roused the camp. Then, as he awoke with the horror of the dream still on him, his eyes fell on the two stretcher beds that looked like biers and the black coffin-like sleeping bag. It was not much wonder that Dutchy was frightened. The camp did certainly have a most ghastly appearance in the vague moonlight that filtered through the trees, and it must have been still more gruesome to see the coffin and biers suddenly burst open and the corpses come running toward him. To prevent any further nightmare we set Dutchy's sleeping bag under the "A" tent, where he would be saved the horror of again waking up in a morgue.

Pack Harness.

In the morning our friends broke camp and started westward. Dutchy and I watched them packing up their goods into a couple of very compact bundles, which they strapped to their backs with a peculiar pack harness. I took careful note of the way the harness was put together, and when we returned to the island we made two sets for use on our tramping expeditions. A canvas yoke was first cut out to the form shown in Fig. 213. We used two thicknesses of the heaviest brown canvas we could find, binding the two pieces together with tape. The yoke was padded with cotton at the shoulders and a strap was fastened to each shoulder piece. These were arranged to be buckled to a pair of straps fastened to the back of the yoke and passing under the arms. Riveted to these straps were a pair of straps used for fastening on the pack. The yoke straps were attached with the rough side against the yoke, while the pack straps were riveted on with the rough side uppermost, as indicated in the drawing.



Fig. 213. Pack Harness.

Riveting.

The method of riveting together the leather straps may need a word of explanation. A copper rivet was passed through a hole in the two straps; then the washer was slipped over the

projecting end of the rivet. This washer had to be jammed down tight against the leather, and to do this we drilled a hole of the diameter of the rivet in a block of wood, and putting this block over the washer, with the end of the rivet projecting into the hole, we hammered the block until the washer was forced down tight against the leather. Then taking a light tack hammer we battered down the end of the rivet onto the washer. Care was taken to do this hammering very lightly, otherwise the end would have been bent over instead of being flattened.

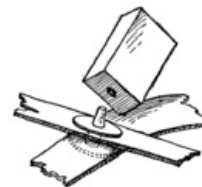

Fig. 214. Riveting the Straps Together.

CHAPTER XIX. THE LAND YACHT.

Only one thing of importance occurred between our Christmas holidays and Eastertide: this was Bill's invention of the tricycle sailboat or land yacht. We had returned to school with sailing on the brain. Our skate sail served us well enough while there was any ice, but as spring came on we wished we had our canoe with us, or even the old scow to sail on the lakes near the school. Once we seriously considered building a sailboat, but the project was given up, as we had few facilities for such work. But Bill wasn't easily baffled, and I wasn't surprised to have him come tearing into the room one day, yelling, "I've got it! I've got it!" In his hands were two bicycle wheels, which I recognized as belonging to a couple of bicycles we had discarded the year before.

"What are you going to do with them?" I inquired.

"I'm going to make a tricycle sailboat."

"What?"

"A tricycle sailboat, a land boat, or anything you've a mind to call it. I mean a boat just like our ice boat only on bicycle wheels instead of skates. We can sail all over south Jersey on the thing. Come on down and help me build it."

The Frame of the Yacht.

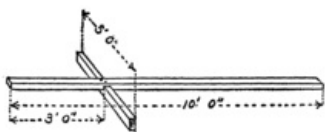

Fig. 215. The Backbone and Crosspiece.

I followed him to the shed at the back of the school and found that he had already procured a couple of scantlings for the frame of the boat. The sticks were 2 inches thick and 4 inches wide. The backbone was cut to a length of 10 feet, and a 5-foot link was sawed off for the crosspiece. The two pieces were securely nailed together about 3 feet from the forward end of the backbone. The crosspiece was set on edge, but a notch was

cut in it about 1 inch deep to receive the backbone. We might have braced the frame with wooden braces, as in the ice boat, but we thought that this time we would vary the design by using wire bracing instead, thus making the frame much lighter. I asked Bill how he proposed to tighten the wire. Turnbuckles were the thing, but I knew that they were rather expensive.

"Just you leave that to me," said Bill. "I've a scheme that I think will work out all right."

A Simple Turnbuckle.

At the hardware store of the town we bought a pound of No. 16 iron wire, eight large screw eyes and six eye bolts, with nuts and washers. Both the screw eyes and eye bolts had welded eyes and the shanks of the eye bolts were 6 inches long. A pair of screw eyes were now threaded into the backbone at each side about 18 inches from the end, and at each end of the crosspieces an eye bolt was fastened. I began to see Bill's plan. He was going to draw the wire taut by tightening up the nuts on the eye bolts. To get the best effect the hole for the eye bolt had to be drilled in on a slant, so that the bolt would pull directly in the line of the wire. To get just the right angle we ran a cord from the screw eye on one side to the point where the bolt was to be inserted, and traced its direction on the crosspiece. The hole for the eye bolt was now drilled parallel with the mark we had traced. The same was done at the other end of the crosspiece. A pair of screw eyes were now screwed into the backbone at the fore end and a pair of eye bolts were set at a corresponding angle in the ends of the crosspiece. The crosspiece was notched at each side so that the nuts and washers on the eye bolts would have a square seating. Then we stretched on the wire guy lines, drawing them as tight as possible, with the eye bolts held in place by a turn or two of the nuts, after which we screwed up the nuts as far as we could, thus drawing up the wire until it was very taut. This done the second nut was threaded onto each bolt against the first so as to lock it in place and prevent it from jarring loose.



Fig. 216. An Eye Bolt.

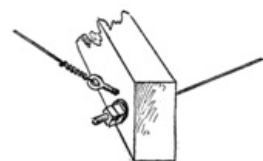

Fig. 217. Stretching the Guy Lines.

Stepping the Mast.

Our next task was to step the mast. We found in the shed an old flagstaff 15 feet long and 3

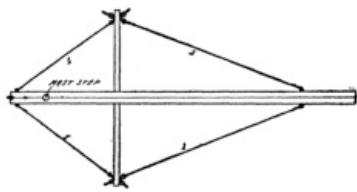

Fig. 218 The Frame with Wire Braces.

inches in diameter. The lower end of this, for about a foot, we whittled down to a diameter of 2 inches, and drove it into a hole in the backbone 12 inches from the forward end. The mast was stayed by a wire stretched from the head to an eye bolt at the fore end of the backbone. The end of the mast which projected below the backbone was stayed with wire running forward to an eye bolt and aft to a screw eye on the backbone, and also with a pair of wires running to screw eyes threaded into the crosspiece near the ends. We couldn't very well use eye bolts on these wires except at the fore end, but we stretched the wires as tight as possible before the screw eyes were screwed all the way in, and then, as we turned the screw eyes, the wire was wound up on them and drawn fairly taut. Fig. 219 shows a side view of the frame, and wires marked 1 and 2 are the same as illustrated in Fig. 218, which is a top or plan view of the frame.

Mounting the Frame on Bicycle Wheels.

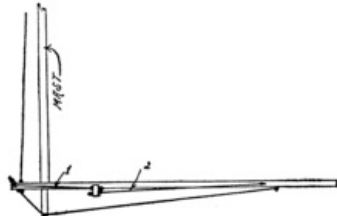

Fig. 219. Bracing the Mast.

We were now ready to mount the frame on the bicycle wheels. We used only the front wheels of the bicycles with the forks in which they were journaled. The shanks at the top of the forks were firmly driven into holes in the crosspiece near the ends. For the steering wheel Bill took the front fork and wheel of his new bicycle, letting the shank into a hole at the stern end of the backbone.

219

The Tiller.

For a tiller we used a piece of an old rake handle. A small hole was first drilled into the handle and the end of the stick was then split through the hole, permitting the projecting shank of the fork to be driven tightly into the hole. The split wood was now tightly closed onto the shank by means of a bolt (see Fig. 220). In the rubbish heap we found an old chair. The legs were sawed off and the seat was then firmly nailed to the backbone. The back of the chair was cut down so that it just cleared the tiller.



Fig. 220. The Tiller.

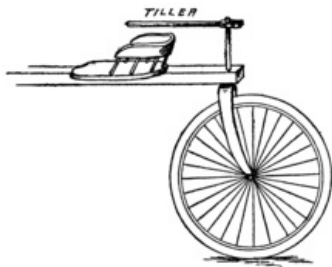

Fig. 221. The Seat.

A "Leg-of-Mutton" Sail.

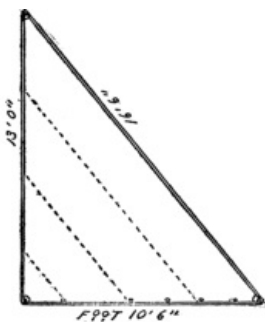

Fig. 222. Leg-of-Mutton Sail.

Everything was now completed but the sail. This was a triangular or "leg-of-mutton" affair, of the dimensions given in Fig. 222. It was made of light canvas, 30 inches wide, of which we bought 14 yards. Out of this we took one strip 18 feet long, one 13 feet, one 8 feet, and one 3 feet long. We had no sewing machine, and therefore had to sew the strips together by hand. The selvedge edges of the strips were lapped over each other about an inch and then they were sewed together sailor fashion, that is, each edge was hemmed down, as shown in Fig. 223. The strips were sewed together so that at the foot each projected at least 21 inches below the next shorter one. This done, the sail was cut to the dimensions given, allowing 1-1/2 inches all around for the hem. The hem was turned over a light rope, forming a strong corded edge. At the clew, tack and head loops were formed in the rope which projected from the canvas, and at intervals along the foot the canvas was cut away, exposing the rope so that the sail could be laced to the boom, as illustrated. The boom was a pole 11 feet long attached to the mast by means of a screw hook threaded into the end of the boom and hooked into a screw eye on the mast, after which the screw hook was hammered so it would close over the screw eye to keep it from slipping off. The sail was raised by a halyard passing over a block at the top of the mast. The sheet was fastened near the end of the boom, passed through a block on the backbone, back of the tiller, and through another block on the boom, and was led to a cleat within easy reach of the chair seat.

Everything was now completed but the sail. This was a triangular or "leg-of-mutton" affair, of the dimensions given in Fig. 222. It was made of light canvas, 30 inches wide, of which we bought 14 yards. Out of this we took one strip 18 feet long, one 13 feet, one 8 feet, and one 3 feet long. We had no sewing machine, and therefore had to sew the strips together by hand. The selvedge edges of the strips were lapped over each other about an inch and then they were sewed together sailor fashion, that is, each edge was hemmed down, as shown in Fig. 223. The strips were sewed together so that at the foot each projected at least 21 inches below the next shorter one. This done, the sail was cut to the dimensions given, allowing 1-1/2 inches all around for the hem. The hem was turned over a light rope, forming a strong corded edge. At the clew, tack and head loops were formed in the rope which projected from the canvas, and at intervals along the foot the canvas was cut away, exposing the rope so that the sail could be laced to the boom, as illustrated. The boom was a pole 11 feet long attached to the mast by means of a screw hook threaded into the end of the boom and hooked into a screw eye on the mast, after which the screw hook was hammered so it would close over the screw eye to keep it from slipping off. The sail was raised by a halyard passing over a block at the top of the mast. The sheet was fastened near the end of the boom, passed through a block on the backbone, back of the tiller, and through another block on the boom, and was led to a cleat within easy reach of the chair seat.

220

221

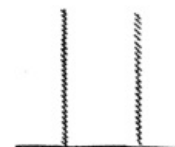

Fig. 223. The Sailor's Stitch.

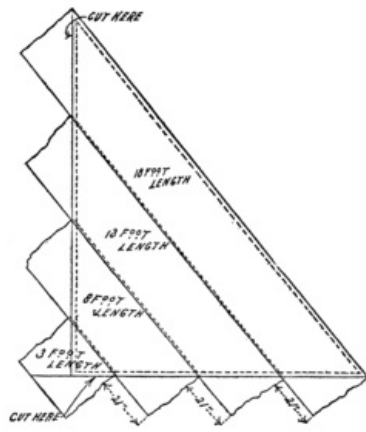

Fig. 224. Laying Out the Sail.

A Sail through the Country.

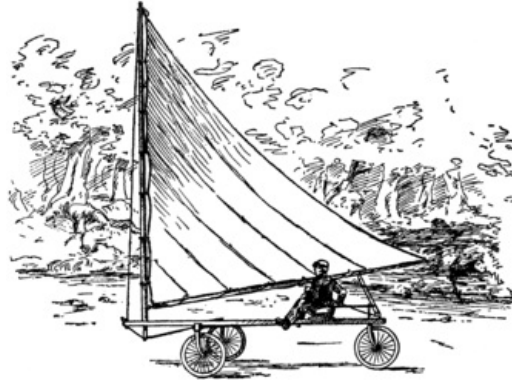

Fig. 225. A Sail on the Land Yacht.

Our land yacht proved to be quite a successful craft in the flat country around the school. Of course, we could not sail everywhere; a country road is too narrow for any tacking when it comes to sailing against the wind. We hadn't thought of that when we made our trial trip. A strong east wind was blowing and so we ventured forth on a road that led due west from our school. Off we sped before the wind for two miles, until we came to a sharp turn in the road. Then we began to think of turning homeward. But this was a very different proposition. The wind was dead against us and to try to tack from side to side of the road was useless, because we would hardly get under way on one tack before we had to swing around on the other tack, losing all our momentum. It ended up by our lowering sail and ignominiously trundling the yacht back to school. After that we carefully selected our course, and never sailed away from home before the wind unless we knew of a roundabout way that would lead us back to port on a couple of reaches (long tacks).

222

223

CHAPTER XX. EASTER VACATION.

224

Just before Easter that year Bill's Aunt Dorothy invited him to spend Eastertide with her and bring along his roommate. I accepted the invitation with alacrity. Bill had once spent a whole summer at his aunt's home, and when we arrived there he had many old haunts to visit. We spent the first day rambling through the woods, in the hills and back of the house.

Bill's Cave.

He introduced me to a cave which he believed was known to only two other boys, both of whom had since moved to New York city. The mouth of the cave was almost closed by a large boulder that had lodged in front of it. We had to climb to the top of this rock, and then letting ourselves down with a rope we slid down the sloping rear face of the boulder into a crevice in the rocks. Then after squirming under a ledge we emerged into a large chamber, which appeared to be as dark as night after our sudden entrance from the outer light.



Fig 226. Sliding Down into the Cave.

Bill lighted a candle which projected from a chink in the wall. By its light I saw that there was a pool in the center of the cave fed from a spring at one point. From the pool the water trickled off into a tiny stream to the mouth of the cave, where it was lost in a crack in the rocks. The water was ice cold and clear as crystal. Around the pool were several chairs and a table made by Bill and his two friends. That was evidently where Bill had gotten his idea of a subterranean club.

225

The Barrel Stave Hammock.



Fig. 227. The Barrel Stave Hammock.

Hanging between a couple of projecting rocks was a hammock made of barrel staves. The hammock was a very simple affair, made by drilling a 1-inch hole in each end of each barrel stave. The staves were then connected by two ropes on each side, woven alternately in and out through these holes, that is, one rope would be passed down through one stave, up through the next, down through the third, etc., and through the same holes another rope would be threaded in and out but in the opposite direction. The end staves of the hammock were provided with double holes, as shown in Fig. 228, so as to make them lie flat, then the ropes were threaded through them.

226

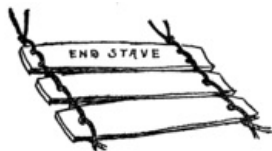

Fig. 228. Tying the Staves Together.

The Barrel Armchair.



Fig. 229. The Armchair Frame.

Aside from the hammock and the rustic furniture there was a fine armchair, made from a barrel that had been sawed off, as in Fig. 229, to form the arms and back. The barrel was raised from the ground by setting it on a couple of boards arranged in the form of a V. Then a caster was fastened to the point of the V and another at each end, making a three-legged chair of it. The chair was upholstered with ticking stuffed with straw. First a piece of ticking large enough for the back was laid on the ground and covered over with an even layer of straw. Over the straw a second piece of ticking was laid, making what Bill called a "straw sandwich." This was nailed to the chair back along the edge and at the bottom, drawing the cloth as taut as possible. To make a better finish for the chair, the ticking was covered with dark red denim. Then strips of braid were laid on the chair back, crossing each other like a lattice. At the crossing points of the braid brass-headed tacks were nailed right through the sandwich into the wood, producing the padded upholstered effect. Next a long, thin sandwich was made to run along the edge of the back, and another one to run around the chair just below the seat, also a couple of small sandwiches to cover the legs and the brackets leading to them. These were all covered with denim before being tacked to the chair and then they were bound with tape at intervals to produce the padded effect. The rest of the woodwork was covered with denim, and a neat ruffle made by Aunt Dorothy hung about the bottom of the chair. A thick, round sandwich was now made to cover the seat board. This was also given a padded effect by binding it with tape. The seat board was not nailed to the chair, but rested on four cleats nailed to the barrel on the inside. When the seat was lifted out it uncovered a shallow chest in which various things could be stored.

227

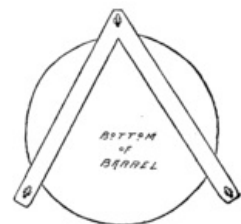

Fig. 230. Casters on the Chair.

228

229

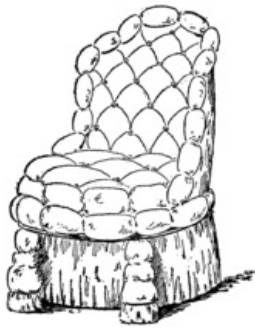

Fig. 232. The Barrel Armchair.



Fig. 231. Tacking on the Straw Sandwiches.

The Summer Toboggan.

Bill informed me that he and his two chums used to spend hot summer afternoons in this cool place whittling out various ornaments and making furniture for the cave. In one corner were a number of home-made amusement devices, one of which struck me as rather odd. It consisted of a pair of large barrel staves, hollow side up and connected with two short boards, as in Fig. 233. Bill said it was a summer toboggan, to be used on grass instead of snow. I had never heard of such an affair, and, of course, had to have a demonstration. Bill went to the top of the hill and from there coasted down the grassy slope in fine style.

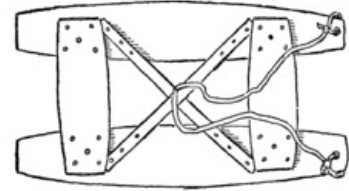

Fig. 233. The Summer Toboggan.

Tailless Kites.

"There's a better place over on the other side of the hill," he said, and led the way to his favorite coasting spot. But here our attention was diverted from coasting by the curious sight of a full-grown man flying a kite. We found out afterward that he was a Professor Keeler, who had made a great scientific study of kites. Professor Keeler was very affable, and we soon got acquainted with him. His kite was way up in the air, almost out of sight, and was pulling like everything. Neither Bill nor I could hold it long. But the most remarkable part of it all to me was the fact that the kite had no tail. I had heard of tailless kites made like a box, but this one appeared to be very much like the kites I had made in my younger days, and I well knew the importance of a long tail to keep such a kite steady. We asked the professor about it, and were informed that this kite was of the Malay type, which is so designed that the cloth bellies out into pockets on each side of the central stick or backbone, and these pockets balance the kite while the backbone acts as a rudder.

Finding that we were interested in the subject he gave us full instructions for making kites from 5 to 8 feet long, and these I jotted down for future use. In a 5-foot kite he said the stick should be $\frac{3}{8}$ inch thick and $\frac{1}{2}$ inch wide, in a 6-foot kite $\frac{7}{16}$ inch thick and $\frac{9}{16}$ inch wide, in a 7-foot kite $\frac{5}{8}$ inch thick and $\frac{3}{4}$ inch wide, and in an 8-foot kite $\frac{3}{4}$ inch thick and 1 inch wide. On the following summer we built a 5-footer and also an 8-footer.



Fig. 234. Coasting in Summer.

A Five-foot Malay Kite.

For the 5-foot kite we used two sticks of hickory $\frac{3}{8}$ of an inch wide, $\frac{1}{2}$ an inch thick, and each 5 feet long. According to directions, one stick was laid across the other at a point two-elevenths of its length from the top. Two-elevenths of 5 feet is a little less than 11 inches, and so we fastened on the cross stick 11 inches from the upper end of the backbone. The sticks were not nailed together, because this would have weakened the frame just at the point where it was under the greatest strain. Instead we followed the professor's directions and tied cleats to each stick, as shown in Fig. 235, so as to form sockets. Then the sticks were laid across each other, each stick fitting into the socket of the other, just like a mortised joint. A coat of shellac on the bottom of each cleat glued it temporarily to the stick, after which it was very tightly bound with fine cord. The stick and cleats were now thoroughly shellaced. The end of each stick was tapered off to receive a brass ferrule of the kind used on chisel handles. They can be bought at



Fig. 235. Tying on the Cleats.

any hardware store. At the end of the backbone we fastened hooks made of brass, bent to the form shown in Fig. 236. The cross sticks were also provided with hooks, but these were double, as shown in Fig. 237, so that a hook lay on both the front and the rear side of the frame.



Fig. 236. Hook on the Vertical Stick.

The frame was covered with a kind of cloth called "percaline." The cloth was hemmed along each edge over heavy picture wire, and at each corner the wire was twisted around a small solid ring of brass. The rings were now slipped over the hooks on the frame and then the cross stick was bowed back by fastening a wire to the rear hooks and drawing it taut. Professor Keeler told us to tighten this bowstring until the distance from the wire to the cross stick at the center was equal to one-tenth of the length of the stick. As our sticks were each 5 feet long we



Fig. 237. Double Hook.

tightened the wire until the cross stick bowed out 6 inches, as in Fig. 239. The belly band of the kite was fastened at one end to the lower end of the backbone and at the upper end to a wire hook at the juncture of the two sticks. The hook was fastened to the cross stick by flattening the ends and running them under the cord used for binding on the cleats (see Fig. 240). A buttonhole was made in the cloth covering to let this hook project through. The belly band was just long enough, so that it could be stretched over to one end of the cross stick, as in Fig. 241, and

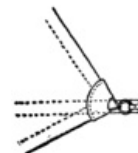

Fig. 238. Connection at Corner.



Fig. 239. Bending the Cross Stick.

at this point, that is, 30 inches from the upper end of the belly band, a brass ring was made fast, to which the main kite string was tied. The kite possessed the advantage that it could be quickly taken apart and folded into a small space.

An Eight-foot Malay Kite.

Our 8-foot kite was made in the same way only the sticks were 3/4 inch thick, 1 inch wide and 8 feet long. The cross stick was fastened 17-1/2 inches (two-elevenths of 8 feet) from the top of the backbone and it was bowed back 9-1/2 inches (one-tenth of 8 feet). The wire in the hem of the covering was a double thickness of the heaviest picture wire obtainable.



Fig. 240. Belly Band Hook.

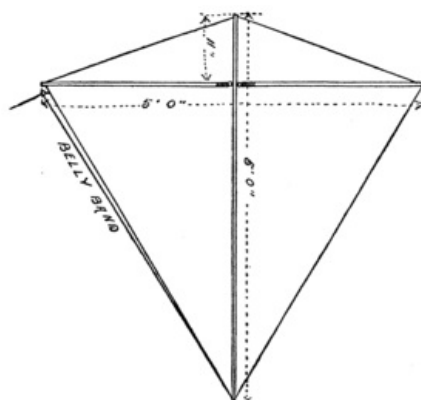

Fig. 241. The 5-foot Malay Kite.

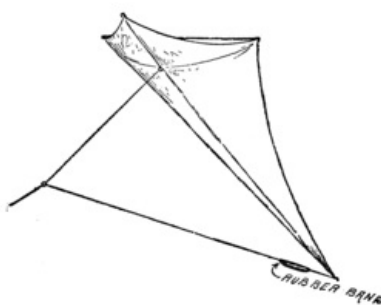

Fig. 242. Malay Kite with Elastic Belly Band.

The Elastic Belly Band.

An important change was made in the belly band of the kite. The lower strand was made elastic by tying it fast to a number of heavy rubber bands, as in Fig. 242. When flying the kite, if a sudden, strong puff of wind struck it, the elastic belly band would give, tilting up the lower end of the kite so that the wind passed under; but as soon as the gust had passed the rubber bands would draw the lower end of the kite back against the wind. The elastic belly band had the effect of making the kite rise almost vertically. Sometimes it would even sail square overhead. The 8-foot kite was a very powerful one. To hold it we had to use a very strong cord, the kind used by upholsterers for tying down the springs in a chair or a sofa.

Putting the Kites to Work.

Bill tested the strength of the kite once by hooking a spring scale to the kite string. The scale was made to register weights up to 25 pounds. But our kite yanked the pointer immediately past the 25-pound mark as far as it would go. We judged from this that the kite would lift at least 40 pounds. Such a pull as this it seemed a pity to waste, but how to utilize the power was a problem until one day, when the kite was soaring up on a south wind, Dutchy suggested that we tie it to one of the canoes and go sailing up-stream. We tried the trick at once, but it didn't work very well, because the canoe was too light. The kite would drop unless there was a heavy pull on the string. We had better success with the scow, however, which provided a sufficient drag on the kite, and with the two kites to pull us we sailed a long ways up-stream, drifting down with the current when we had gone as far as we cared to.

The Diamond Box Kite.



Fig. 243. The Scow Towed by Kites.

Professor Keeler also gave us instructions for making a diamond-shaped box kite, and though we never built one, it may not be amiss to publish his instructions here. I quote from the chronicles of the S. S. I. E. E. of W. C. I.:

“Materials: Four sticks, 1/4 inch thick by 5/8 inch wide by 44 inches long, for the corner sticks. Two sticks, 1/4 inch thick by 5/8 inch wide by 15 inches long, for the short spreaders. Two sticks, 1/2 inch square by about 38 inches long, for the long spreaders. Two strips of cloth 81 inches long, hemmed at each edge to a width of 13 inches. Whittle out

twelve cleats to the form shown in Fig. 244. At the ends of the 15-inch spreaders nail cleats on each side with long wire brads, so as to form forks, as shown in Fig. 245, in which two of the corner sticks are held. The short spreaders are fastened to the corner sticks, 7 inches from the ends,

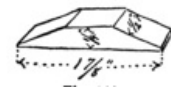

Fig. 244. Cleat for Spreader.

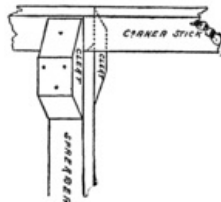

Fig. 245. Corner Stick and Spreader.

with brads driven through the cleats, making the frame (as in Fig. 246). To prevent the frame from skewing off sidewise it should be braced with wire running diagonally across from one corner stick to the other. Ordinary soft stovepipe wire will do. Care must be taken to have the spreaders meet the corner sticks squarely or at right angles. Now take one of the cloth strips and sew its ends together to form a band. The end should be lapped about an inch and fastened with the sailor stitch (see Fig. 223). The same should be done to the other cross strip, and then each band

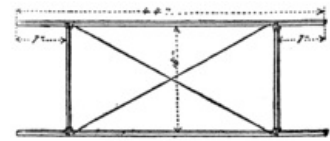

Fig. 246. The Narrow Frame.

should be marked off with pencil lines at four points, all equidistant from each other. The two bands may now be tacked to the two ends of the frame with opposite pencil lines over the edges of the corner sticks, as in Fig. 247. The two remaining corner sticks are then nailed to the bands at the two other pencil lines. These corner sticks will now be braced apart by the long spreaders, which are

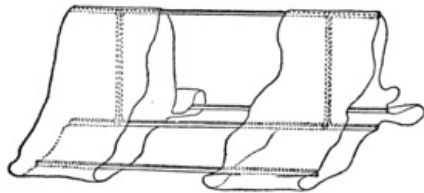

Fig. 247. Tacking on the Cloth.

notched to the right length to stretch the cloth taut. A cleat is nailed over each notch, as shown in Fig. 248, forming forks to hold the corner pieces. The long spreaders are now forced down until they meet the short spreaders, to which they are tied with waxed string. The long spreaders may be nailed to the corner sticks by driving brads right through the cloth into the cleats and the sticks. The belly band may be fastened to any one of the corner sticks at the spreaders, and from the points where it is tied it should measure about

45 inches in length. The point where the main string should be attached to the belly band may be best determined by experiment.”

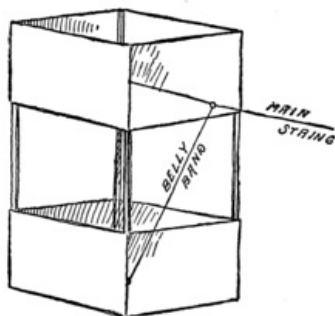

Fig. 249. The Diamond Box Kite.

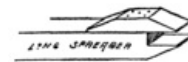

Fig. 248. Forked End of Long Spreader.

Summer found us again on Willow Clump Island with heads full of new ideas. Bill had come across an old copy of Ewbanks' "Hydraulics" in the school library. It was a book describing machines of the ancients—principally devices for raising water. Rather dry reading, I thought, even though it was a wet subject; but Bill seemed to find it absorbingly interesting. I came in late one afternoon, after a glorious game of baseball, only to find Bill poring over the yellowed leaves of the "Hydraulics" as fascinated as most fellows would be over a detective story. It exasperated me to note that he thought more of this old book than he did of our baseball team.

"Bill," I exclaimed, "what's got into you? I can't for the life of me see what is so entertaining in that prehistoric book."

"Oh, go way. Don't bother me," was the surly reply.

But I wouldn't be put off that way. Quickly I snatched the book from his grasp and threw it out the window.

"Now, sir," I cried, "maybe you will kindly explain to me why you persist in studying that old volume, to the neglect of our baseball team."

"Don't get so excited, old chap," he replied. "That book is all right. I'm studying up some new schemes for next year's expedition to Willow Clump Island. Why, there are lots of things in that old book that we can make." And he proceeded to unfold his plans, sketching out some curious designs of water wheels and pumps.

By the time school closed for the summer Bill had thoroughly digested that volume, and was ready to reconstruct many of the ancient machines.

The Water Wheel.

Our first work on reaching the island was to erect a water wheel, or "noria," as it was called in the book, in front of the camp. It had been a great nuisance to keep our filter barrel full. Every few days we would have to form a bucket brigade, passing pails of water up the line until the barrel was filled. Now Bill proposed to do away with all this bother and let the river do the work for us.

Surveying for the Water Wheel.

We first determined the height of the upper filter barrel above the level of the river. This was done with our surveying instrument, which was set level with the top of the barrel. We sighted with the instrument to a long pole that was held upright at the edge of the water. The pole had been marked off into feet with white chalk marks, and on sighting through the sight holes we found that the hairs came in line with the eleventh chalk mark. The top of the filter was, therefore, 11 feet above the level of the river. Bill figured that it would be necessary to construct a wheel about 15 feet in diameter in order to raise the water to the proper height.

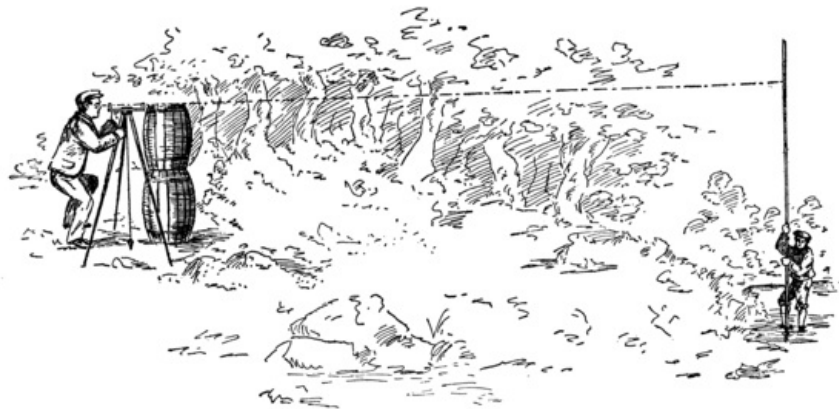

Fig. 250. Surveying for the Water Wheel.

Towers for the Water Wheel.

First we built the towers to support the wheel. One tower was 16 feet high and the other only 10 feet. The large tower was made something like a very tall and narrow saw-horse. Two stout poles 17 feet long were flattened at their upper ends and nailed together, with the ends projecting about a foot, as shown in Fig. 251. At the bottom these poles were spaced 8 feet apart by a cross bar, and about 9-1/2 feet from the bottom a pair of boards were nailed to opposite sides of the pole to serve as supports for the axle of the water wheel. Another pair of 17-foot poles was now similarly fastened together and then the two pairs were spaced about 12 feet apart and connected at the top and bottom with boards.

At the top two smooth boards were used and these were nailed to the inner sides of the projecting ends, which were tapered off. In this manner a V-shaped trough was formed. The boards were firmly nailed together at their meeting edges so as to prevent them from warping apart. A diagonal brace at each corner made the wedge-shaped tower very substantial. A number of cleats nailed to one of the poles provided a ladder by which we could mount to the top of the tower. The shorter tower was a three-legged affair, made of three 12-foot poles. At first two of these were flattened and nailed together at their upper ends, and they were braced at the top

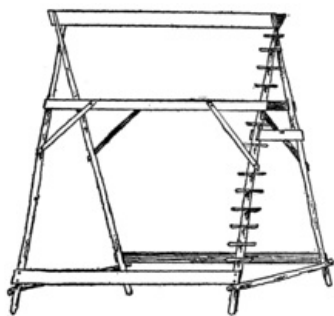

Fig. 252. The Large Tower.

and bottom. The third leg was then nailed in place and braced by cross bars connecting it with the other two poles.

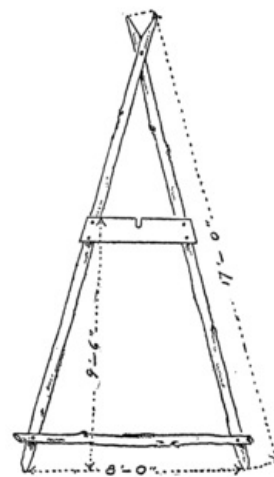

Fig. 251. Frame for Large Tower.

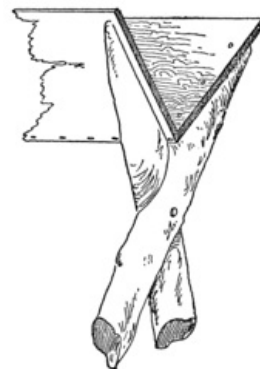

Fig. 253. V-shaped Trough.

The Wheel.

We were now ready to make the wheel. From Lumberville four 1/2-inch boards, each 3 inches wide and 15 feet long, were procured; also a bar of iron 3/4 of an inch in diameter and 2 feet long. At the center of one of the boards a block of wood 4 inches long and 4 inches in diameter was nailed on for a hub. A 3/4-inch hole was now drilled through this hub and the board. Holes were also drilled into the other boards at their centers. Then they were all strung onto the bar and spaced like spokes at equal angles apart. Bill had figured it out some way that the ends of the boards should be just about 5 feet 10-1/2 inches apart. When the boards were all arranged we nailed them together at the center, and connected the ends with narrow tie boards, as indicated in Fig. 256.

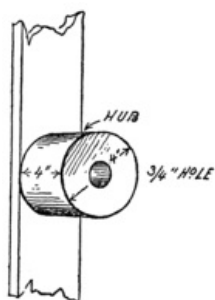

Fig. 255. The Hub.

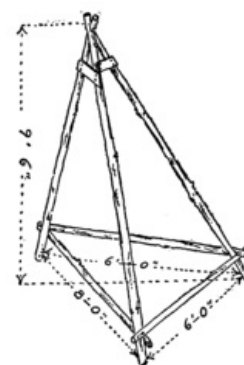

Fig. 254. The Small Tower.

The Buckets.

Eight large tomato cans were now procured and fastened to the spokes at the ends on the inner side, that is, the side the hub was nailed to. We couldn't very well nail on the cans, so we punched two holes in the side of each can and then secured them to the spokes by passing bolts through these holes and the boards.

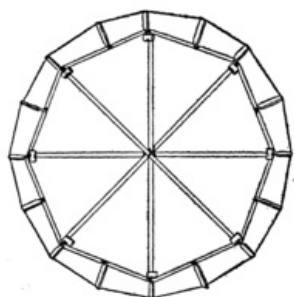

Fig. 256. The Water Wheel.

The Paddles.

Then we cut sixteen paddles of the form shown in Fig. 257. Eight of these were 12 inches long, and the rest measured 18 inches. A slot 3 inches deep was cut in each paddle of just the right width to slip over the tie boards. The shorter paddles were fastened on just back of the spokes, and the rest were secured half-way between each spoke. The paddles were braced by stretching a wire from one to another all the way around the wheel.



Fig. 257. A Paddle.

The Receiving Trough.

Our next task was to nail the receiving trough in place on the higher tower. We set up the towers on land and mounted the wheel between them with the axle resting in the crotch of the short tower and in a deep notch cut in the cross boards of the larger one. The cans on the wheel faced the larger tower, but the hub at the center and a block nailed to the larger tower spaced the wheel far enough out so that the cans did not strike the tower as they revolved. We carefully measured the distance between the spokes and the larger tower, and then built a square trough

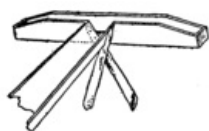

Fig 259. The Receiving Trough.

of a size to just fit into this space. This trough was nailed across the end of the V-shaped trough on top of the tower, but a notch was cut in the side so that the

water would pour from the square or receiving trough into this V-shaped one. The square trough was about 8 feet long and its sides were 12 inches high; but at the ends we had to cut them down to a height of but 6 inches, so as to permit the cans to pass without hitting them.

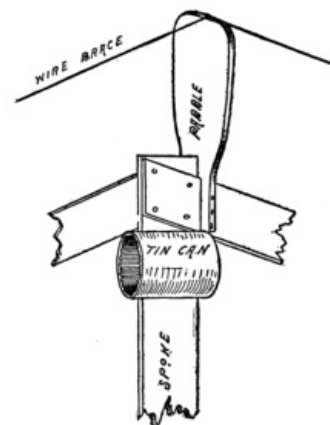

Fig. 258. How the Paddles and Cans Were Attached.

Setting Up the Towers.

Our filter was located nearly 20 feet from the end of the river, and in order to get a good current of water to revolve our wheel we had to place it about 15 feet from shore. This necessitated building a trough line 35 feet long. Ten feet of this line were already provided in the top of the tall tower. This tower was now set up in place with the legs firmly wedged into holes excavated in the bottom of the river. The legs on the shore side were sunk a little deeper, so as to tilt the trough slightly shoreward. The outer end of the trough was about 12 feet above the level of the water. We needed but one more tower to support the remainder of the trough line. This tower was built like the first one, but was much shorter, as it was erected on land and the level of the trough at the top had to be 5 or 6 inches lower so as to make the water flow. We connected the towers by another V-shaped trough section. This we nailed to the under side of the first trough and to the inside of the second trough. The latter was then in the same way connected by a trough section with the upper filter barrel. We now rigged up our shorter tower about a foot from the taller one, wedging in the legs so that the top came level with the slotted boards of the other tower.

Mounting the Water Wheel.

Then came the task of mounting our wheel in place. We were working in a pretty strong current and found it no easy matter. In the first place, the wheel was floated down to the towers, but there it got jammed and we couldn't lift it up. One of the paddles was broken and a bucket wrenched off before we could disentangle the wheel from the towers, and then the wheel was carried quite a distance down-stream before we could drag it in to shore.

Our next attempt was more successful. This time we anchored the wheel so that it just cleared the towers, then fastening a couple of long guy ropes to it, we raised the wheel on edge, while a boy stood on each side holding the ropes to keep the wheel steady. The anchor rope was now slowly paid out and the wheel was rolled in between the towers. This done, the wheel was lifted up and the axle rod was pushed in, with the ends of the rod resting in slots of the boards on the tall tower and in the crotch on the shorter one. To prevent the axle rod from working endwise out of its bearings, we nailed pieces of wood across the crotch and the slots against the ends of the rod. Then we cast off the anchor rope and our wheel started work, the cans dipping up the water as they were carried around by the wheel and pouring it out of the top into the receiving trough, from which the water flowed down into the filter barrel.

Cooling the Filter Barrel.

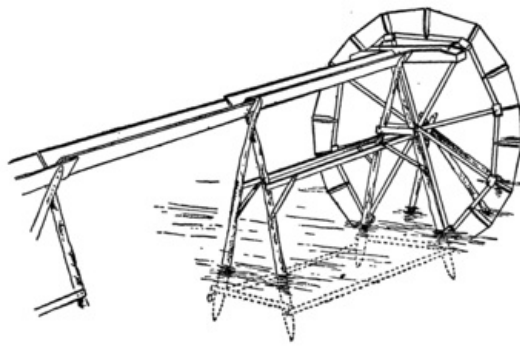

Fig. 260. The Water Wheel in Action.

The trough line was very leaky and a great deal of water splashed out of the buckets. But for all that, within a few moments our barrel was full and overflowing. We hadn't figured on its filling so rapidly, but we soon found a way of utilizing the surplus water. It was led to a half-barrel in which we washed our dishes, and from there it flowed through a ditch back to the river. The water for the wash barrel was taken from the top of the upper filter barrel. But we let the lower filter barrel flow over so that it would be kept wet on the outside. Our filter was fortunately placed at a point where a good breeze struck it, and we shoveled away the earth that had been piled around it so that the wind playing on the wet barrel evaporated the moisture, making the water inside very cool.

250

251

The Canvas Bucket.

This same trick was used for cooling our drinking water whenever we went off on an expedition away from camp. We had a heavy canvas bucket, the kind used on ships. We would fill this bucket with water and then hang it up in the wind. The water seeping out of the pores of the bucket would be evaporated by the wind, and this would, in a few moments, make the water inside delightfully cool. Such buckets may be bought for \$1.50 to \$2.00 apiece, but ours was a home-made affair, and made somewhat differently from the store kind. The canvas used was the heaviest we could find. A piece 9 inches in diameter was cut out for the bottom. A ring 7 inches in diameter, made of heavy brass wire, was laid on the canvas, and the cloth was turned over it and sewed down the inside of the ring. For the sides of the bucket we cut a piece 14 inches wide and 23 inches long. The upper edge was strengthened by a piece of light rope held in place by hemming the cloth over it. The lower edge was now sewed to the bottom, just inside the wire ring and then the ends of the piece were joined, completing the sides of the bucket. The bail of the bucket was formed of a piece of rope fastened to the roped upper edge of the bucket.

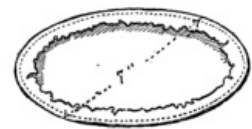

Fig. 261. Bottom of Bucket.

252

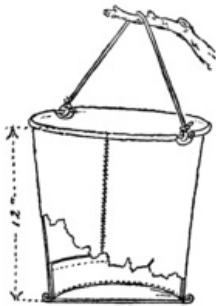

Fig. 262. The Canvas Bucket.

But to return to the current wheel; the day after it was completed, when I went over to Lumberville for the mail, I was met by old Jim Halliday, who wanted to know what sort of a rig we had out on the river. I told him, and after a dint of much persuasion, induced him to take a ride back in the scow with me. He had never visited our camp and hadn't realized how handy we were with the tools, because, with the exception of the current wheel, all our work had been done on the opposite side of the island. We made him a guest of honor, showing him over the whole place. The bridges struck him as remarkably clever, but what pleased him most was our current wheel.

"I swan," he said. "Ef that ain't jest the thing I have been awantin' for the past twenty year. What'll ye sell me the hull plant fer, boys?"

Mr. Halliday's Water Wheel.

We thought he was fooling at first, but when he had assured us that he was in earnest, Bill told him that we needed our own plant, but we could build him a similar and even better current wheel for any amount he thought it was worth to him. The figure settled on was six dollars (a dollar apiece) for our work, Mr. Halliday paying for the material. It was not a large sum, but it seemed a lot to us, and considering the scarcity of money in that region it was pretty generous pay. We built Mr. Halliday's current wheel just like our own, except that the paddles were much broader, and instead of using cans for the buckets Mr. Halliday supplied us with small dinner pails. The method of fastening on the pails is shown in Fig. 263. A stick was nailed across the end of each spoke and the bail of the pail was held by a screw eye threaded into this stick. The pails would hang straight, holding all the water without spilling a drop until the receiving trough was reached. This trough was fastened high enough to strike the bottom of the pails as they went by, tipping them over and emptying them of their contents. From the trough the water ran directly into a large cider barrel and from here was carried through a pipe to Mr. Halliday's barn. A stopcock was here provided so that he could turn the water on or off, as he desired. The use of pails was a great improvement on tin can buckets. Fully three times as much water was poured

253

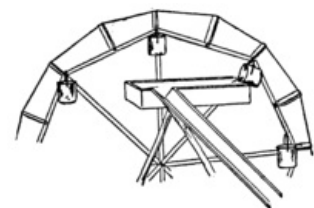

Fig. 263. Mr. Halliday's Water Wheel.

CHAPTER XXII. THE LOG CABIN.

Immediately after fitting out Jim Halliday with his water wheel we set to work on our log cabin. As a model we had a photograph of a log hut which Uncle Ed had sent us. As the cabin was designed particularly for use in winter time, we decided that it should be located where it would be sheltered from the northern winds and would be exposed to the sun. The ideal spot seemed to be on the southern shore of Kite Island, which was backed by a thick grove of trees but gave an unobstructed view in front for a distance of about four miles down-stream.

Foundation of Log Cabin.

First we staked out the plan of the house. It was to be 12 feet long by 10 feet wide, so we leveled off a space of this area, and at the corners, where the greatest weight of the building would come, large rocks were embedded in the ground.

A Logging Expedition.

The logs for the house were cut from a tract of wooded land about five miles up the river, belonging to Mr. Schreiner. To be sure we could have cut the timber from our own island, but when Reddy had said something to his father about our building a log cabin, Mr. Schreiner had warned us not to cut down any of the trees without the owner's permission. All we could learn about the owner was that his name was Smith, and that he lived somewhere in New York city. It seemed unlikely that he would ever have anything to say about our cutting down a few trees, but rather than run any risk Mr. Schreiner advised us to make use of his woods for any timber we might need. Accordingly we started out early one morning on a logging expedition. We had no apparatus for handling any logs more than 6 or 8 inches in diameter, and Bill reckoned it out that we would have to have about fifty logs of this size for the sides of the building alone. This did not mean that fifty trees had to be chopped down, because we could usually cut two logs from a single tree. As the logs would have to overlap about a foot at each corner, we had to cut the longer ones to a length of 14 feet and the others to a length of 12 feet. Aside from these we had to have several 16-foot logs for the roof. Only the straightest logs were chosen, and while Bill and Reddy wielded the axes the rest of us hacked off the small branches with hatchets and hauled the sticks down the river. Here we tied them together to make a raft.

The Log Raft.

This was done by running a pair of ropes alternately over and under the logs at each end (see Fig. 264). About fifteen were thus fastened together, and then as an extra precaution a log was laid across each end of the raft and tied fast. As soon as we had cut enough timber for our first raft, we all ceased work, to take a ride down the river on the logs. Two of us, armed with poles, were to do the steering. There was one spot in the river of which we were rather apprehensive. That was a bit of shallow, swift water three miles from camp. A line of rocks jutted up from the river, forming a natural dam which was broken only at the eastern end. The water swirled madly through this opening, and veering off a huge rock which lay directly in front of the gap turned sharply westward. As we neared this dam the river became deeper and deeper, until finally we could no longer reach bottom with the poles, and could not properly steer the boat. For some time we drifted helplessly round and round in the still water above the dam. Then suddenly the current caught us and we swept like a shot for the opening. The gap was quite wide, and had we only thought to provide ourselves with oars we could have steered the raft clear of the rocks below, but we were entirely at the mercy of the current, and with a terrific crash we were hurled head on against the boulder.

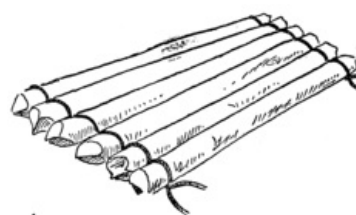
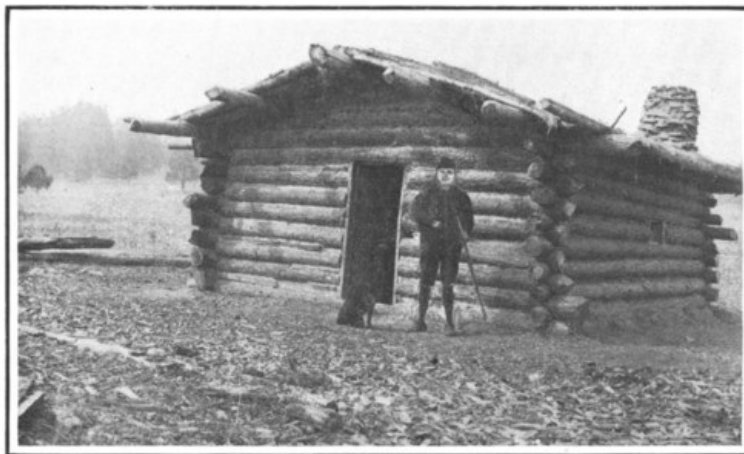

Fig. 264. Tying the Logs Together.



Getting Dinner.



The Photo after which Our Log Cabin was Modeled.

Just what happened then I can not say. When I undertook to record the incident in the chronicles of the S. S. I. E. E. of W. C. I., I found there were five entirely different versions of the affair besides my own. I knew that immediately after the shock I found myself struggling in the water just below the rock over which I must have been slung by the force of the impact. Dutchy declared up and down that he had sailed fifty feet in the air astride of a log. Bill had been almost stunned by a blow on the head and was clinging desperately to a jagged projection of the rock. The ropes that had held the raft together had parted, scattering the logs in all directions, and I could see the rest of the crew hanging on to them for dear life.

Shouting to Bill to let go his hold on the rock. I swam over and caught him as he drifted down, then I helped him ashore. Leaving Bill to recuperate I rushed down the bank, shouting to the others to paddle the logs over toward shore. Then I plunged in, and pulling myself up on the nearest log, paddled shoreward as we had done on the planks when shooting the rapids. In this way one by one we corralled the logs, and after tying them together again resumed our voyage down the river. We now had no swift water to fear and were able to guide the raft successfully down to Lake Placid. But here we moored it, not venturing to take it past the mill-race until we had gotten the oars from the scow and nailed on oar locks at each side and the rear, so that we could properly row and steer the raft safely to Kite Island.

258

The Sail-Rigged Raft.

When we went up the river again we carried the oars with us, also the sail and mast belonging to our ice boat, as there was a good breeze blowing down-stream. Our second trip was more successful. The mast was stepped in a small but solid box nailed to the logs. In the top of this box a hole was cut for the mast to fit into and then the mast was braced with guy lines. We came down the river in fine style, steering straight for the opening in the dam, and just as we were about to shoot through Reddy and I plied the oars for all we were worth on the port (left) side so as to swing the raft around past the boulder. However, we didn't escape entirely without accident, for the raft rode up on a submerged ledge, dipping the starboard side clear under water and nearly tipping us over. But in a moment the raft had righted itself and we had smooth sailing for the rest of the way.

259

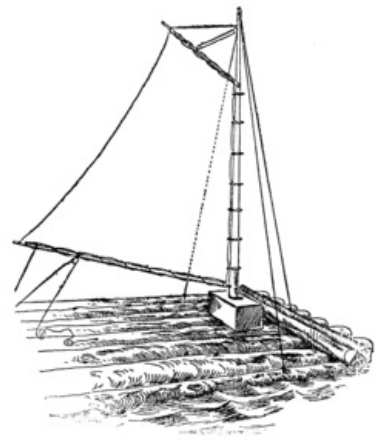

Fig. 265. A Sail-rigged Raft.

Building the Log Cabin.

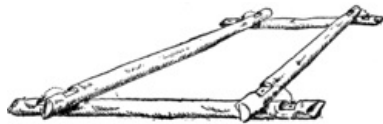

Fig. 266. Foundation Logs Notched.

Our third expedition completed the number of logs we required for the log cabin. Two large 12-foot logs were chosen for the foundation logs at the front and rear of the building. The logs were flattened along the bottom so that they would have a firmer bearing on the ground, and particularly on the corners, where they rested on foundation stones. Each log was now notched about a foot from the ends. The notches were 8 inches long and about 2 inches deep. Care was taken to place those on one log squarely opposite the notches on the other. A pair of 14-foot logs were now laid across the foundation logs and rolled along them until another half-turn would have dropped them into the notches (shown in Fig. 266). Then notches were cut in the 14-foot logs to correspond, so that when the final half-turn was given one notch would fit over the other, making a mortise joint (Fig. 267). When the side logs were in position notches were cut in their upper surface to receive a pair of 12-foot logs which were rolled onto them, notched and dropped into place. Then another pair of side logs were laid on, and so the work progressed. The notches in each log were cut to a depth equal to one-quarter the diameter of the log; that is, if the log was 8 inches in diameter the notch was made 2 inches deep, and if 6 inches in diameter it was cut to a depth of 1-1/2 inches. When the logs were laid in place no space intervened between them, as will be clearly understood by reference to Fig. 268.

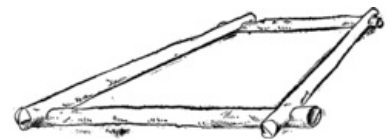

Fig. 267. Foundation Logs Fitted Together.

We found, after a few logs had been set in place, that our cabin was growing faster at one end than at the other. The trouble was that our logs were not of uniform diameter throughout, and we had been laying the butt ends, which were larger, all at one end of the building. So we had to take down the logs and relay them with the butt end of the front foundation log at one end and that of the rear foundation log at the other. Then the cross logs were laid on with their butt ends on the small ends of the foundation logs. The next end logs were laid with their small ends on the butt ends of the cross logs, and so on, taking care never to lay the butt end of one log across the butt end of another. In this way the walls were built up evenly to a height of 3 feet.

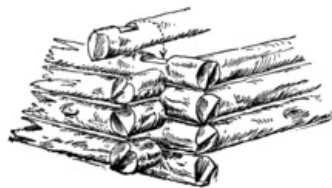

Fig. 268. A Corner of the Log Wall.

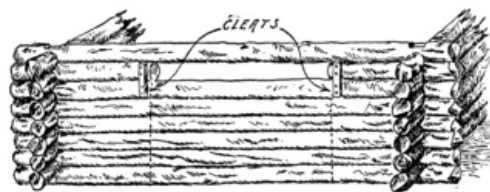

Fig. 269. Piece Cut Out to Admit Saw.

We had planned to make a large open fireplace in the cabin, and this necessitated cutting an opening in the rear wall. But we did not want to cut the opening until the wall was built up to its full height lest it might buckle while the remainder of the logs were being placed in position. So we merely cut a piece out of the top log to make room for a saw when we were ready to cut the complete opening. As our fireplace was to be 5 feet in width, a 5-foot piece was cut out of the center of the log. Then the ends were supported by cleats nailed on each side, as shown in Fig. 269. This done the building was continued as before, but as the walls grew we found it more and more difficult to raise the logs to position. We could not lift them directly to the top of the wall, but had to roll them up on "skids"; that is, on a pair of 14-foot logs which were laid against the top of the wall. When the walls had reached a height of about 5 feet above the foundation logs, a length 4 feet 9 inches long was cut out of the top log to allow space for sawing out the front door and window, and also a 30-inch piece was cut out for the side window. Cleats temporarily held the sawed ends of the logs, while the walls were carried on up to a height of a little over 6 feet from the foundation logs.

The Roof of the Log Cabin.

Then we started laying the roof. A 16-foot log was now notched in place at each side, with its forward end projecting about 3 feet over the front of the cabin to form a shelter in front of the building. A pair of 12-foot logs were then laid in position. The next pair of 16-foot logs were laid about 20 inches in from the sides, and after a pair of the cross logs had been set in place a third pair of logs were laid about 40 inches from the sides. Finally, a single 16-foot log was set in place at the center, to serve as the ridge beam of the roof. The roof logs were all carefully tested to see if they were sound before we laid them in place, because we did not want to run any risk of the roof falling in, particularly in the winter time, when it would be heavily covered with snow. A chalk line was drawn from the ridge beam to the lower roof beam, and the cross logs were sawed off along this line, as indicated in Fig. 271. Several slabs were now procured and laid across the roof beams to serve as rafters. These rafters projected about 18 inches beyond the side walls of the cabin, so as to support the eaves. Over the rafters we laid a roofing of slabs, starting with the bottom and lapping them, as we had done on our tree house.

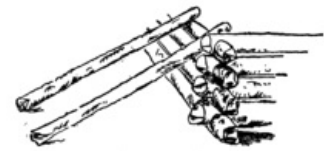

Fig. 270. Skids

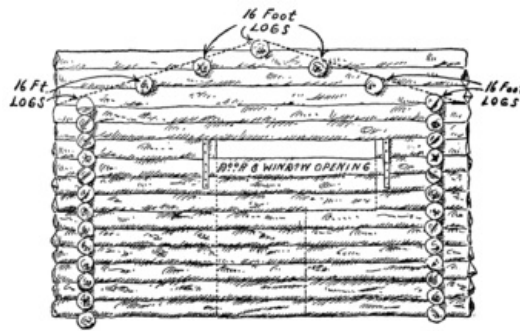

Fig. 271. How the Roof Logs were Laid.

The Door and Window Frames.

We were now ready to cut out and frame the doors and window openings. The front window of the cabin was to be close beside the door, so we merely widened the door opening at the top to include the window opening as well (see Figs. 271 and 272). The door was made 2-1/2 feet wide, and was cut down to the foundation logs. The window opening was cut to a depth of 24 inches. Before sawing out the opening we wedged pieces of wood between the logs along the line we were to follow with the saw, so as to keep them in place. After the opening had been made a couple of stout boards were nailed to the sawed ends of the logs at each side, to hold them securely in place and make a suitable framing for the door. The cleats were then removed. The foundation log and the one at the top of the opening were flattened, to serve as the sill and lintel of the door. Between the door and window a short post was wedged in place. This post was flattened on opposite sides, so that the door jamb could be nailed against it on one side and the window frame on the other. The side window was next cut out and framed. After it had been framed it measured 2 feet square.

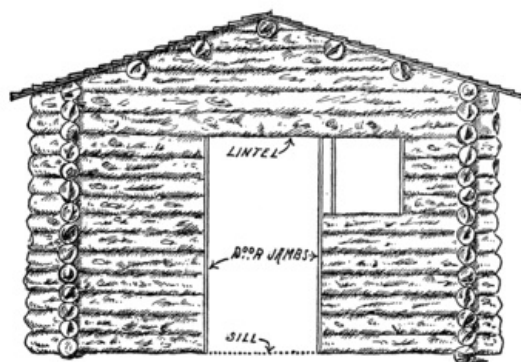

Fig. 272. The Finished Roof.

The Fireplace.

Then came the task of building our fireplace. First we sawed out the opening, cutting right through the rear foundation log. Then we gathered from the river a large number of the flattest stones we could find. With these we planned to build the three outer walls of our chimney. But the question of getting mortar to bind the stones together bothered us for a while.

"If only we could find a bed of clay. Don't any of you know of one around here?" queried Bill.

But none of us remembered seeing any clay bed in the vicinity.

"If we were in south Jersey now," I said, "we could use some of that red mud they have down there. It sticks like the mischief to shoes and pant legs. I bet it would hold those stones together."

"Red mud? Why there's plenty of it over the hill, back of Lumberville," said Reddy. "All the roads

over there are red shale roads, and I saw some red banks along the river when we went after the logs."

That was just what we wanted. The banks Reddy referred to turned out to be genuine red shale, and soon we had ferried several scow loads of the stuff down to Kite Island. When the shale was wet it made quite a sticky mortar. The foundations of the chimney were laid in a trench about 2 feet deep, and the side walls of the chimney were carried inside of the cabin and covered the ends of the logs at the chimney opening. The side walls extended outward a distance of 3 feet, where they were joined by the rear wall of the chimney.

The Proper Way to Build a Stone Wall.

In making our chimney we could not rely on the red shale to hold the stones as firmly as good lime mortar would, so we had to be careful that each stone, as it was laid, had a firm bearing. The stones were embedded in a thick layer of mud, and if they showed any tendency to teeter we propped them up by wedging small stones under them until they lay solid. Another thing that we were very careful about was to "break joints"; that is, to keep the joints in each layer of the stones from coinciding with those in the next layer, above or below. To make sure of this we made it a point to lay a stone over each joint in the top of the wall and then to fill in the space between the stones with smaller stones. In this way the wall was made very substantial.

When the masonry had been carried up to the top of the chimney opening, a heavy timber about 12 inches wide was laid across the walls close against the wall of the building. This was to support the fourth wall of the chimney, and so we flattened its upper surface. To prevent it from catching fire it was covered with a thick plastering of mud, and then to keep the mud from cracking and flaking off we procured a piece of tin and tacked it over the log. The tin also extended over the top log of the opening. Then we went on with the building of the chimney walls, carrying them up about a foot above the ridge of the roof. Our chimney was completed by paving the bottom with stones, well packed in mud and nicely smoothed off to make the hearth. The hearth extended about 18 inches into the cabin, and was framed with logs, as shown in Fig. 275.

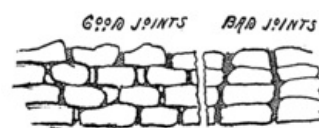

Fig. 273. How to Build a Wall.

The Floor of the Cabin.

A number of logs were now laid on the ground to serve as floor beams. Slabs were used for the floor. We had some trouble in making the floor perfectly even, because the floor beams were rather irregular, and a great deal of time was spent in smoothing the logs off to a common level. If we had the work to do over again we would have bought two or three planks and laid them on edge to support the flooring.

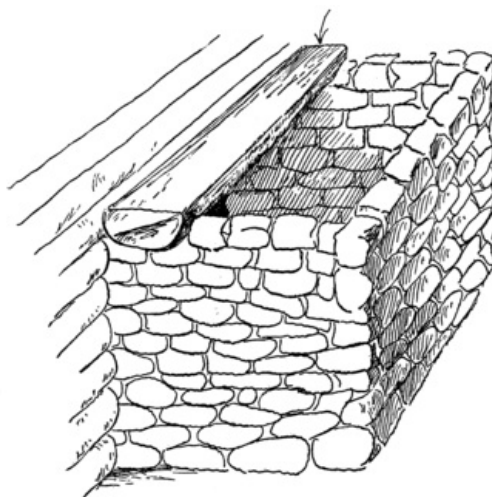

Fig. 274. Building the Chimney.

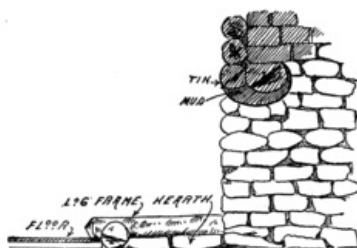

Fig. 275. Section through the Fireplace.

The Door Hinges and Latch.

A door was now constructed by battening together a number of slabs. In place of a hinge a hole was drilled into the sill and another into the lintel directly in line with it. Two sticks of wood were

then whittled to fit snugly, but without jamming, into these holes. These sticks were then nailed to the inner face of the door, with their whittled ends projecting into the holes, forming pintles on which the door could turn. A narrow strip of wood was nailed to the outer jamb for the door to close against. The latch consisted of a stick of wood, fastened to the door at one end with a nail. It hooked onto a catch whittled out of hard wood to the form illustrated in Fig. 278, and nailed to the jamb. Then to

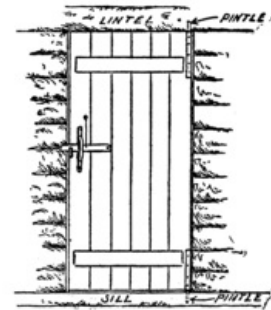

Fig. 276. The Door Hinges.



Fig. 277. The Latch Guard.

keep the latch from dropping too far when the door was open, and to guide it when slammed against the catch, we whittled out a guard piece to the form illustrated in Fig. 277, and nailed this to the door, with the latch projecting through the slot of the guard. A string was now fastened to the latch and passed through a hole in the door. A block was tied to the end of the latch string to prevent it from slipping back through the hole; but at night, when we did not want to be

molested by any intruders, we untied the block and drew in the latch string.



Fig. 278. Door Catch.

The Window Sash.

For our windows we made wooden sashes which fitted nicely into the window openings. A small hole was drilled through the sash at each side into the frame, and nails inserted in these holes held the sash in place, and served also as hinge pins for the sash to turn on. The sash could be taken out at any time by removing these nails. As we could not afford to use glass for our windows, we covered the sashes first with cloth, and later, when it occurred to us that in winter time it would be difficult to keep the cold air out, we used oiled paper.

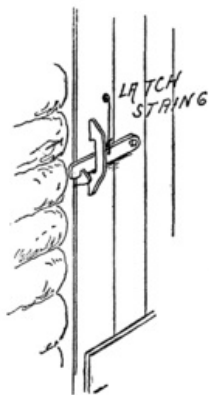

Fig. 279. The Latch.

Bunks.

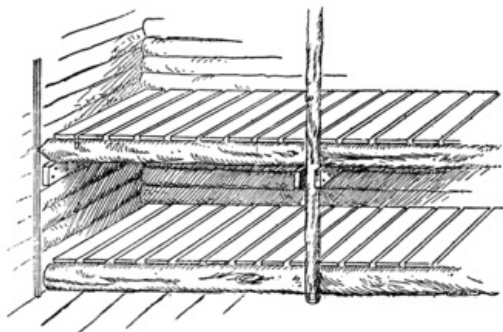

Fig. 281. Bunks.

Our next work was directed toward providing sleeping accommodations in the log cabin. A large log was laid on the floor the full length of the cabin, as far out as possible without interfering with the opening of the front door. Stakes were laid across this log, with their opposite ends wedged in between the logs of the wall. A nail or two in each slab held it in place. This formed a sort of shelf 12 feet long, which was divided at the center to form two bunks, each wide enough for two

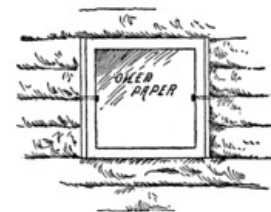

Fig. 280. Hinged Window Sash.

persons. But as there were six of us in the society, we had to provide two more berths. A stout post was set into a hole in the ground, and nailed firmly at the bottom to the lower berth log and at the top to one of the roof beams. This post supported a second berth log, which extended the full length of the building at a height of about 3 feet from the floor, and was wedged at the ends between the logs of the house. Cleats were nailed to the walls under this berth log to make it perfectly secure. Then slabs were nailed across it to form the two bunks.

Stopping up the Chinks.

The log cabin was completed by stopping up all the chinks between the logs of the walls. Strips of wood and bits of bark plastered with mud were driven into all the cracks and crevices until everything was made perfectly tight.

When our log cabin was completed we immediately transferred our camp from the tent to the hut. But at the very outset we were confronted with the problem of getting drinking water. We hadn't thought of that before. It was easy enough to move the filter barrels, but when it came to moving the water wheel we could find no suitable place for it anywhere near the log cabin. The water of Lake Placid was too quiet, while the mill-race and the rapids on the other side of Kite Island ran so swiftly that we were afraid the water wheel would be swept away with its course. The matter was carefully considered at a special meeting of the society. It occurred to Bill that we might build a windmill in place of the water wheel, and use it to pump water from a well which could be dug near the hut.

"We wouldn't have to use a filter, then," he said.

"Why not?" I asked.

"Why, because the sand of the island will strain out all the dirt in the water. You see, the water in the well will have to soak in from the river, and by the time it gets through all the gravel and sand between the river and the well it ought to be filtered pretty clear."

Digging the Well.

That sounded logical, and so we adopted the plan at once. We chose a spot quite near the hut for our well. When we had dug down about 6 feet we struck water, but continued excavating until the water lay 3 feet deep in the well. While making the excavation we shored up the sides with planks, to prevent the loose soil from falling in on us and smothering us, as it so nearly did when we were digging our first cave. By "shoring," I mean we lined the walls with planks, which were driven into the ground with large wooden mallets. The planks were braced apart with sticks at frequent intervals. As the well hole grew deeper we had to rig up a bucket to haul the dirt out. Our bucket was a soap box attached to a rope, which passed through a pulley at the top of the well. The pulley was supported by a tripod made by firmly lashing together the upper ends of three stout poles and spreading their lower ends far enough apart to straddle the mouth of the well, as shown in Fig. 282. After the well had been carried down to a sufficient depth, we began laying the stone wall, which was to form the permanent lining. We knew that the wooden walls would not do, because they would soon decay. Our stone wall, which was built up of flat stones like the chimney of the log house, was not very strong, I fear, and had not the soil around it been pretty firm it would probably have caved in. However, if it served no other purpose, it formed a fairly good finish for the well.



Fig. 282. Digging the Well.

The Windmill Tower.

The mouth of the well was carefully covered with planks while we constructed the windmill above it. For the tower of the windmill we chose four long sticks. They must have measured about 16 feet in length, and were from 4 to 6 inches in diameter. With them we made two frames of the form given in Fig. 283, using slabs to brace them apart. These frames were now set in position, with their lower ends firmly planted in holes in the ground, and the tower was completed by nailing on a number of diagonal braces. A couple of boards were nailed across the upper ends at opposite sides, and holes were drilled through them to provide bearings for the wind wheel shaft.

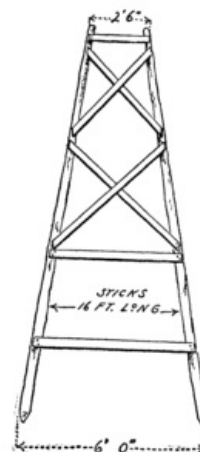

Fig. 283. Frame for the Tower.

The Crank Shaft.

The shaft was a piece of heavy iron rod which we procured from the blacksmith at Lumberville. Under Bill's direction the blacksmith hammered a U-shaped bend at the center of the shaft, so as to form a crank, and then he flattened the rod near the ends (see Fig. 284). When the shaft was set in its place these flat spots lay just outside of the bearing boards, and then, to keep the shaft from sliding back and forth in its bearings, we fastened on two clamps over these flattened parts. The clamps were made of pairs of hardwood blocks bolted together in the manner indicated in Fig. 285.

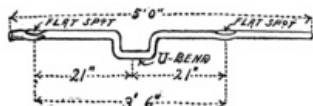

Fig. 284. The Crank Shaft.

The Wind Wheel.

Our next task was to construct the wind wheel. First we procured three boards, each 3 inches wide and 3-1/2 feet long. A 1/2-inch hole was drilled in the center of each board, and then, with

these holes coinciding, the boards were nailed together, with their ends projecting, like spokes, equally distant from each other. Six wedges were now made of the size indicated in Fig. 286. These were made of a 2 x 4-inch scantling, sawed diagonally in two and then planed down to the given dimensions. The wedges were now nailed firmly to the spokes, as shown in Fig. 286. For the blades we used six thin boards, each about 4 feet long. Each blade measured 10 inches in width at the outer end, and tapered down to a width of 3 inches at the inner end, as illustrated in Fig. 288. The blades were now securely nailed to the wedges, and their outer ends were braced

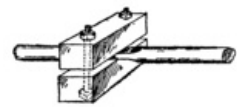

Fig. 285. A Clamp.

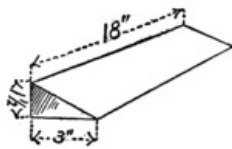

Fig. 286. Wedge for Wind Wheel.

together by means of wires stretched from the forward edge of each blade to the rear edge of the next one ahead. The wheel was then fitted onto the shaft and nailed to one of the clamps. In this way it was practically keyed to the shaft.

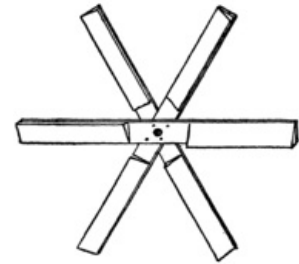

Fig. 287. Spokes of Wind Wheel.

We did not make any vane for our windmill. It did not need any. The wind nearly always blew either up or down the river, more often up the river, for the prevailing summer winds in that part of the country are southerly. But, aside from that, east and west winds could not very well reach us on account of the hills on both sides of the river. The wheel was set facing the north, because the strongest winds came from that direction, and as an extra brace against these winds we stretched wires from the projecting end of the shaft to the center of each blade.



Fig. 288. Wind Wheel Blade.

A Simple Break.

A brisk northerly wind was blowing when we set the wheel in place, and it began to revolve at once, before we could nail it to the clamp. To stop it we nailed a stick of wood to the tower, so that its end projected in the path of the blades and kept the wheel from turning around. This brake was swung up to the dotted position illustrated when we were ready to have the wheel revolve, but it could be thrown down at any time to stop it.

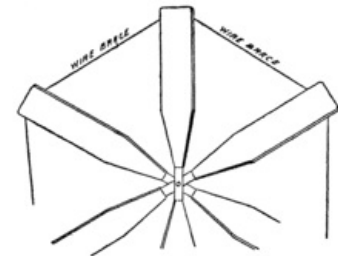

Fig. 289. The Wind Wheel.

The Pump.

Our pump was made of a galvanized leader pipe; that is, a pipe used to carry off rain water from the roof of the house. The pipe was only about 8 feet long, and so we had to piece it out with a long wooden box pipe. A block closed the lower end of this box, and the leader pipe fitted snugly into a hole in the block (Fig. 291). A spout was set into the upper end of the box pipe to carry the water to the cask, which was to serve as our water reservoir.

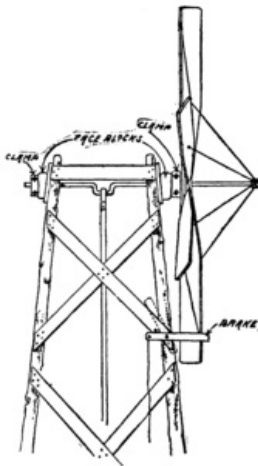

Fig. 290. Side View of the Wind Wheel, showing Brake.

The Pump Valves.

We plugged the bottom of the leader pipe with a block of wood, in the center of which a large hole was drilled. The hole was covered with a piece of leather nailed on one side, so that it could lift up to let water into the pipe. The piston was made of a disk of wood of slightly smaller diameter than the inside of the pipe, and over it was fastened a piece of leather just large enough to fit snugly against the walls of the pipe. This piston was fastened to a wooden rod long enough to reach from well within the pipe to the wind wheel shaft. A strip of brass was bent over the crank, or U-shaped bend in the shaft, and its ends were fastened to the rod.

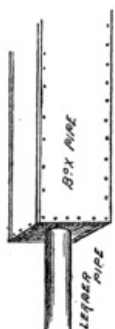

Fig. 291. The Box Pipe.



Fig. 292. The Lower Valve.

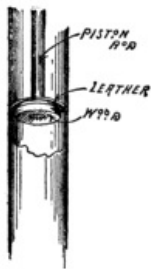

Fig. 293. The Piston Valve.



The Old Windmill at Work on a Lumberville Farm.

Action of the Pump.

It was rather a crude pump, but it did all the work we required of it. As the wheel went around the crank shaft would move the piston up and down. Whenever the piston went down, the air in the pipe would press up the edges of the leather disk and squeeze past (see Fig. 295). Then when the piston came up again, the leather disk, being backed by the wooden disk beneath it, was kept flat, so that no air could force its way back into the pipe. This made a partial vacuum in the pipe, and the water from the well rushed up through the valve at the bottom to fill it (see Fig. 296). When next the piston went down the bottom valve closed and more air forced its way past the piston. Then on the next upward stroke more water flowed into the pipe, until, after a number of strokes, all the air was pumped



Fig. 294. Connection of Rod and Crank.

out and the water which took its place began to force its way up past the piston and eventually to flow out of the spout into the cask.

Our old windmill was sold to a farmer near Lumberville when we broke camp that fall. We carted it over and set it up for him. A number of years later I saw it still faithfully at work pumping water for his cattle. The original pump had been worn out and a new one substituted, but otherwise the old windmill remained just as we had first rigged it up.

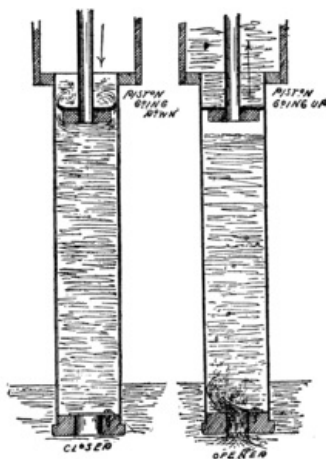

Fig. 295. Fig. 296. Action of the Pump.

CHAPTER XXIV. THE GRAVITY RAILROAD.

"About all we lack now," said Dutchy, when the windmill had been completed, "is a railroad."

"Then suppose we build one," was Bill's unexpected rejoinder.

We all thought he was joking, but he wasn't.

"I don't mean a steam railroad," he said, "but a gravity railroad."

"A what?"

"A gravity railroad. Oh, you know what that is—a roller toboggan—the kind they have down at

Coney Island." And he went on to explain how we could rig up a simple roller toboggan on our island.

His plan was to build an inclined trestle on the high ground just below the lagoon, and then run wooden tracks along the shore down to the pontoon bridge, and across the mill-race to Kite Island. We started first to dig a road down to the bridge, because the bank was quite high at this point. The task was rather greater than we anticipated, but we kept steadily at it until we had cut a fairly good road through the bank, though the grade was rather steep.

Before proceeding with the trestle and track we thought the best plan would be to build our car, and then we could use it as a gauge to determine how far apart the rails should be set.

The Car.

First we got a 2 x 4-inch scantling, and cut from it two lengths, each 4 feet 6 inches long. These were laid on edge just 30 inches apart, and then a number of boards were nailed across from one scantling to the other and sawed off flush with their edges. The floor thus formed was now turned over so that the scantlings lay uppermost and the sides of the car were then nailed on with their edges overlapping the ends of the floor boards. The sides, which were about 18 inches high, were each made of two boards firmly battened together. Great care was taken to securely nail both the flooring and the sides to the scantlings, because these scantlings were to carry the wheels of the car. The car body was completed by nailing on the end pieces which overlapped both the flooring and the side walls.

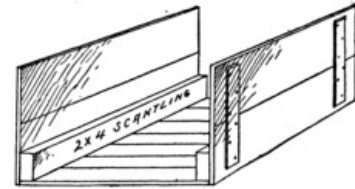

Fig. 297. Putting the Car Body Together.

The Flanged Wheels.

Next we sawed out the wheels of our car. From a board of hardwood 3/4 of an inch thick four disks, 12 inches in diameter, were sawed out. Then from a board 1 inch thick four 9-inch disks were sawed out. We cut these disks in the same way as we had made the disks for our surveying rod (see page 78), by making cuts across corners and finally smoothing off the angles with a draw-knife. A half-inch hole was now drilled in the center of each disk. Then on each large disk a smaller one was placed, with the center holes of the two coinciding and the grain of one lying across the grain of the other. In this position they were firmly nailed together, making a wheel like those used on a railway car, with the small disc forming the tread of the wheel and the large disk serving as a flange.



Fig. 298. The Car Wheel.

The Car Axles.

For the car axles we bought four 1/2-inch bolts, 6 inches long, with two washers and two nuts for each bolt. In each side of the car, about 8 inches from the ends, we nailed face blocks; that is, blocks of wood for the wheels to bear against. These face blocks were only 1/2 inch thick. Then in these blocks holes were drilled which were carried clear through the scantling. The holes were just large enough for the bolts to fit snugly in them. The bolts were inserted from the inside, so that their threaded ends projected out at each side of the car. A patch of wood was nailed to the scantling over each bolt head to prevent the bolt from slipping back into the car. Then the wheels were mounted on these bolts, which served as axles.

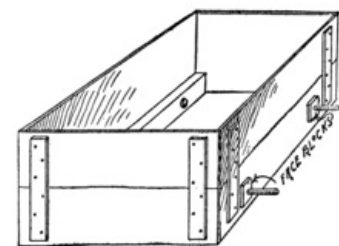

Fig. 299. Car Body with Axles in Place.

Mounting the Wheels.

First a washer was placed on the axle, then the wheel was applied, with the larger or flange disk against the face block, after which another washer was slipped on. A nut was screwed against this washer just tightly enough to keep the wheel snugly in place, and yet let it turn freely on its axle. Then to keep this nut from shaking loose a second nut was screwed on against it. While one fellow held the first nut from turning, another screwed the second nut against it as tightly as he could. The second nut is technically known as a "jam nut," or "lock nut." The car was completed by laying a couple of boards across from one scantling to the other to serve as seats.

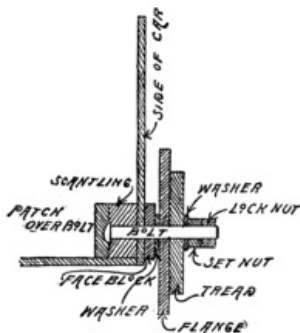

Fig. 300. Section Showing How to Fasten on the Wheel.

The Railway Track.

The trestle was now begun. First we erected a level platform, which was to be the starting point of the railway. This was made very substantial by planting the corner posts firmly in the ground and then bracing them together with diagonal braces. A couple of planks leaning against the

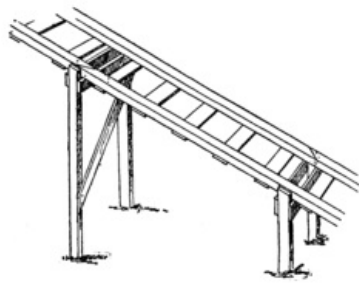

Fig. 301. The Inclined Trestle.

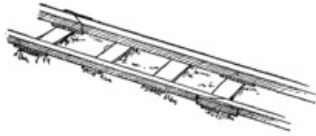

Fig. 302. Joints of the Track.

platform at one side provided a convenient means for mounting to the top. From the platform the trestle ran down at an easy incline to the ground. It was made of 2 x 4-inch scantlings supported at intervals on posts driven into the ground. The opposite posts were firmly braced with boards fastened diagonally across them. The scantlings were to serve as rails, and so we fastened them at the proper distance apart with ties nailed to the under side. But to be sure that the rails were not too far apart or too close together, the car was rolled over the track and the rails were set to keep the tread disks of the wheels on them and the flange disks just clear of their inner edges. The ends of the rails were cut off at an angle, making a slanting joint, as shown in Figs. 301 and 302. They were fastened firmly together by nailing a piece of board on the bottom and also on the outer side.

288

The Carpenter's Miter Box.

To make sure that the ends were all cut to the same angle, we made a carpenter's "miter box." Two sideboards were nailed to a baseboard, making a trough large enough for the scantling to be set in it. Then we sawed through the sides of the trough at an angle of 45 degrees. When we wanted to cut the end of the scantling at an angle it was placed in the trough, and with the saw set in the saw cuts, as a guide, we were sure that they would all be cut at the same angle.

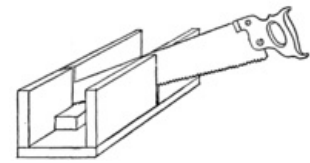

Fig. 303. Carpenter's Miter Box.

289

Laying the Track.

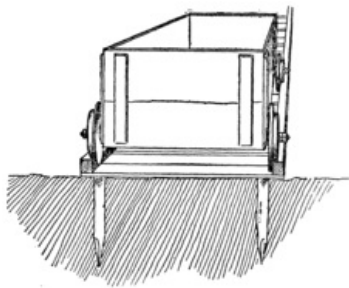

Fig. 304. How the Track was Anchored.

From the bottom of the inclined trestleway we continued the track down the slope to the river; but for the sake of economy, instead of using 2 x 4-inch scantlings for the rails, we bought a number of 2-inch planks at Lumberville, and had them sawed up into strips 2 inches wide. These 2-inch square rails were fastened together with slabs nailed on at frequent intervals. To maintain the proper gauge the car was rolled over each pair of rails, which were nailed first at the ends and center. To anchor the track we drove short posts into the ground so that their upper ends lay flush with the surface. A post was provided under each joint and one under the center of each rail, and then the slab ties were nailed securely to these posts. In imitation of a full-sized railway, we made it a point to "break joints" on our track; that is, to make the end of one rail come in line with the center of the opposite rail, as shown in Fig. 302. Our track was continued across the pontoon bridge and ran around the west shore of Kite Island. The track was straight as far as the shore of Kite Island, whence, by an easy curve, it was carried around to the log cabin.

The First Railway Accident.

Dutchy was the first one to try the railway. He sneaked back to the platform while the rest of us were putting a few last touches on the track. The first we knew the car came tearing down the track at full speed, with Dutchy yelling at the top of his voice for us to get out of his way. Bill was on the bridge when the car came along and he had no time to run for shore, but with great presence of mind he jumped into the water and clung to one of the barrels. But the joke of it all was that Dutchy himself got a wetting too. The track at the middle of the bridge was not quite true to gauge. It was this very spot that Bill was fixing up when Dutchy came along. The end of a rail was bent in far enough to catch the flange of one of the car wheels, and in a moment Dutchy, car and all, was slung head over heels into the mill-race. Fortunately no serious harm was done. Dutchy landed a little ways down-stream, and Reddy, by quick work, managed to rescue the car just as it was floating off under the suspension bridge. The car was undamaged except that the flange of a wheel was split off.

290

Of course, Bill was as mad as a hornet at Dutchy, and expressed his feelings in no mild terms. But his anger was somewhat tempered by the fact that Dutchy received as bad a punishment as he had inflicted.

291



The Start of the Gravity Railroad.

Testing the Track.

We had to cut a new flange disk for the broken wheel, and to prevent the flanges from splitting off again we nailed a batten across the inner face of each wheel extending down to the very edge of the flange disk. This batten was fastened on across the grain. When everything was completed the car was started down the track empty to see if it would keep the rails. It went beautifully as far as the bridge, but was too light to run much beyond. The next time we loaded it up with stones and had the pleasure of watching it sail down hill, across the bridge and vanish out of sight around the shore of Kite Island. That was demonstration enough. We knew it would carry us safely and it did. The next time we tried it four of us piled into the small car, and in a moment we were off on a most thrilling ride, which ended right in front of the log cabin, where the car came to a sudden stop after riding off the end of the rails and plowing through the sand for a short space.

CHAPTER XXV.

THE CANTILEVER BRIDGE.

292

There is one more piece of work done by our society which yet remains to be described, and that is the cantilever bridge. This we all voted to be the greatest of our achievements on the island. To be sure, it was Uncle Ed's design, but I think we justly deserve credit for the masterful way in which it was erected. In our search for types of bridges before building the king post bridge, we came across a simple cantilever bridge that didn't look very difficult to construct. To be sure, none of us knew a thing about stresses and strains, and ingenious though we were, Bill realized that the task of designing a cantilever bridge was far beyond him. Nevertheless, we were sure we could build one if only we had a good set of plans. A letter was therefore mailed to Uncle Ed, asking him for the required details. The answer came promptly from Western Australia, asking us to send him the exact width of the water we wished to span, the depth of the water, the distance from the top of one bank to the top of the other, and the exact height of the banks above water level. We decided we would build the bridge across the mouth of the lagoon. The distance here between the two banks measured a little over 60 feet. The banks were very precipitous, and rose 13-1/2 feet above the level of the water. All these details, together with soundings of the bottom, all the way across, were sent to Uncle Ed, and on the day after our railway was completed quite a bulky package was received in answer. It contained complete directions for building the bridge of wooden frames, which were so designed that they needed merely to be hooked together to form the bridge, though to make the structure perfectly safe Uncle Ed cautioned us to tie the frames together wherever they met.

293

I am half afraid to tell my readers how to build this bridge, as it required the utmost care, and had to be built just so to avoid disaster. Bridge building is a serious business, and I would not advise any one to attempt building this, of all bridges, who does not propose to follow instructions implicitly. Uncle Ed told us that if we built it properly, and with sound timbers, we would find the bridge strong enough to support a dozen boys, but he warned us not to crowd more than that number on it.

Frames for the Cantilever Bridge.

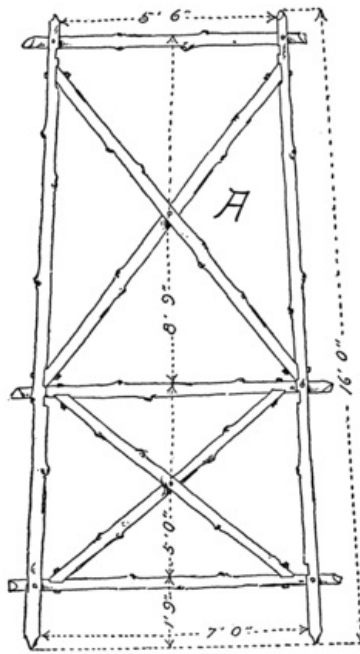

Fig. 305. A Frame (make four).

The frames with which the cantilever bridge was built were made of saplings from 3 to 4 inches in diameter. We procured them from Mr. Schreiner's lands up the river. In making the frames the sticks were fastened together with 1/2-inch bolts 6 inches long. It was quite a strain on our pocketbooks to buy these bolts, but Uncle Ed had written that nails or spikes would be useless to stand the strains of so large a bridge, and that if we could not get any bolts we had better give up the idea of building a cantilever bridge. To make sure that we made no mistakes, Uncle Ed had made a drawing of each different size of frame we would need, designating each with a different letter, and then these same letters were marked on a general view of the bridge, so that we would know exactly where the frames belonged. These drawings are reproduced here in Figs. 305 to 316 and

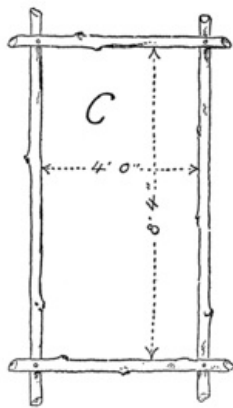

Fig. 307. C Frame (make four).

318. We had to make four frames each, of the *A*, *B*, *C* and *E* sizes, two each of the *F*, *G* and *L* sizes and one each of the *H*, *I*, *J* and *K* sizes. Of the *D* frames two were made with the ends cut away on the outer half, as illustrated in Fig. 308, and two were cut away at the inner side, the reason for which will appear presently. When fastening the timbers together we cut notches in each stick, as shown in Fig. 317.

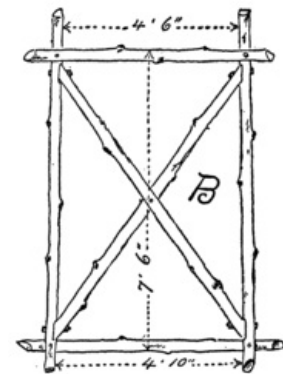

Fig. 306. B Frame (make four).

The depth of each notch was just one-quarter the diameter of the stick; that is, the notch was 3/4 of an inch deep in a 3-inch stick and 1 inch deep in a 4-inch stick. Care was taken not to exceed this depth, for fear of weakening the sticks. In the case of frame *D*, the sticks were not notched or mortised together. It will be noticed that the measurements are given to the inner edges of the sticks in some cases, and to the outer edges in others. The reason for this, as Uncle Ed explained it, was because the thickness of our sticks would vary considerably, and it was

important that many of the measurements be exact, otherwise the frames would not fit into each other as they should. Another thing to which he called our attention was the fact that frames *A*, *B*, *E*, *F*, *H*, *K* and *L* were stiffened with cross braces, while the rest were not. The braced frames, he wrote, were those which would be under a compression strain, while the others would be under tension; that is, when any weight was placed on the bridge it would push against the ends of the braced frames, trying to crush them, but would pull on the unbraced frames, trying to tear them apart. In fact, the bridge would have been just as strong had we used heavy iron wire in place of the unbraced frames, and the only reason Uncle Ed did not recommend our doing so was because we had no simple way of stretching the wire taut.

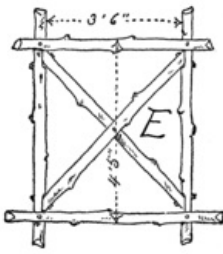
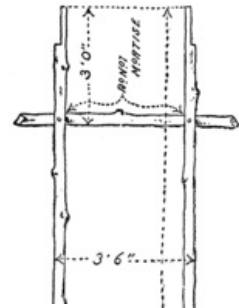

Fig. 309. E Frame (make four).



(make four).



Fishing off the Cantilever Bridge.

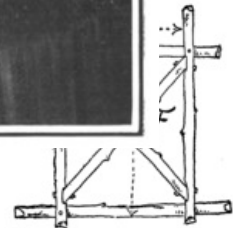

Fig. 310. F Frame (make two).

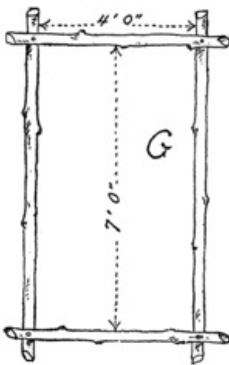

Fig. 311. G Frame (make two).

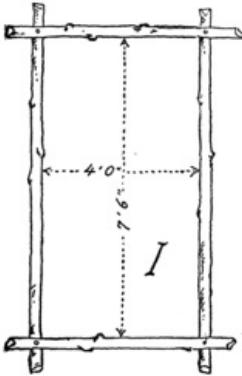

Fig. 313. I Frame (make one).

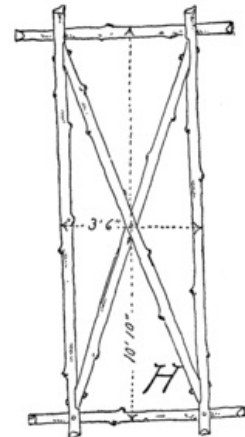

Fig. 312. H Frame (make one).

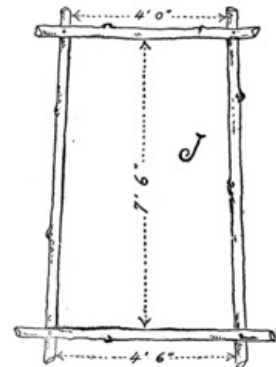
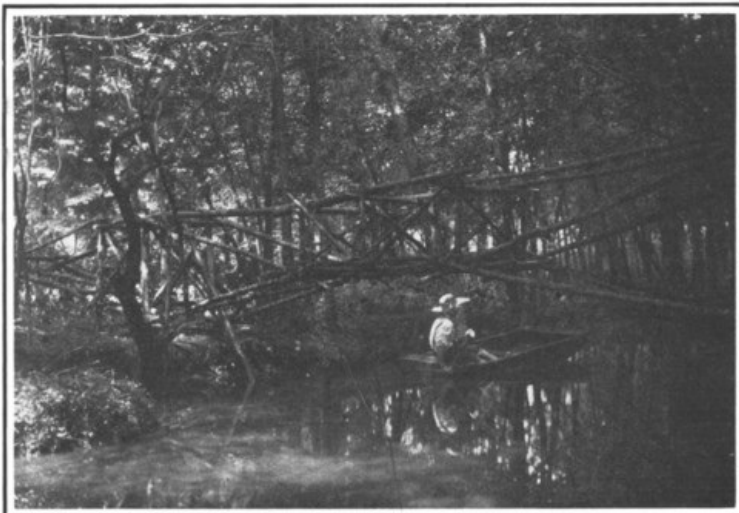

Fig. 314. J Frame (make one).



The Cantilever Bridge in Reddy's Back Yard.

Erecting the Towers.

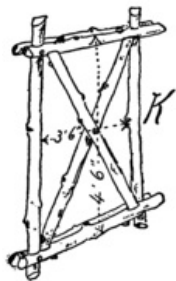

Fig. 315. K Frame (make one).



Fig. 317. Notching the Sticks Together.

We built the complete set of frames before attempting to erect the bridge. Then we began by building the towers. Two *A* frames were set on end and spaced 4 feet apart at the top and 5 feet apart at the bottom, measuring not from the inner but from the outer edges of the frames. In this position they were connected by short spars, notched in place. The notches for these connecting spars will be seen in Fig. 305 on the main or vertical timbers of frame *A*, just below the upper and middle cross sticks and above the lower cross sticks. The upper connecting spars were wedged tightly under the cross sticks, and served as an additional support for them.

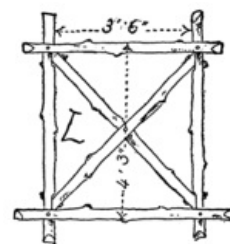

Fig. 316. L Frame (make two).

Diagonal braces were nailed from one frame to the other, as illustrated in

Fig. 318. The towers were built on opposite banks, at the mouth of the lagoon, and when completed we lowered them

carefully down the banks into the water. According to directions they were to be set just 30 feet apart, measuring from the center of one tower to the center of the other. The water was quite shallow

where the towers rested, but the bottom was pretty firm. Holes were dug in the bottom for the legs of the tower to set into, and then large stones were piled around each leg to provide a firm foundation for the towers.

Setting Up the Frames.

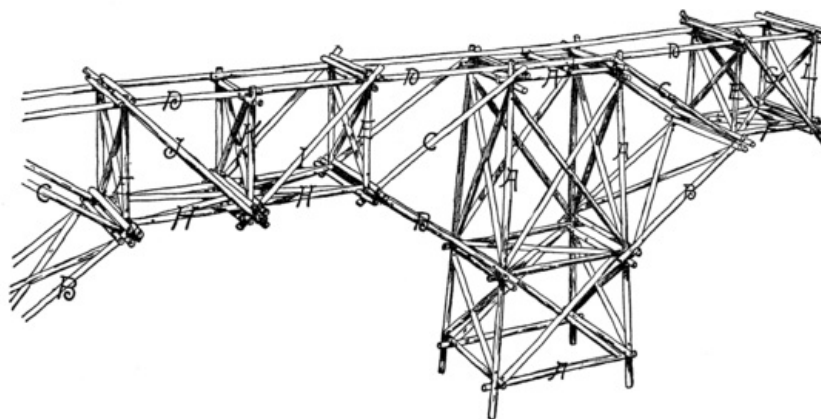

Fig. 318. View of Part of the Bridge, with Letters Indicating the Various Frames.

A *B* frame was now hauled out to one of the towers and lifted by its narrower end, with fall and tackle, until its lower tie piece rested on the projecting ends of the center crosspieces of the tower. The upper end of the frame was held against the top of the tower, while a *C* frame was hooked over the upper ends of the tower legs; then frame *B* was allowed to swing outward until its smaller end locked with the outer end of frame *C*. It will be observed in Fig. 306 that the upper crosspiece or tie piece of frame *B* was fastened to one side of the vertical sticks and the lower tie piece to the other side. This was done purposely, so that when the frame was set in position the bottom tie piece would be on the lower side of the frame and the top piece would lie on the upper side, as shown in Fig 318, or, better still, in Fig. 319. The rest of the frames were all arranged to be set in place with their tie pieces on the lower side, or facing the towers, as will be clearly understood by examining the illustrations. As soon as the *B* and *C* frames were set up on one side of the tower, another pair of *B* and *C* frames was set up on the other side of the same tower. A cantilever bridge must always be built out on both sides of the tower at the same time, otherwise it will be overbalanced on one side and topple over. After the *B* and *C* frames were in place we took two *D* frames, with oppositely cut ends, and rested their tie sticks on the top of the tower, just under the ends of the *C* frames. The ends of the two *D* frames overlapped at the center of the tower, and, as one was cut away at the outer side and the other at the inner side, they fitted neatly together and were fastened with bolts. The *D* frames were supported near their outer ends with *E* frames, which rested on the *B* and *C* frames. Fig. 319 shows an *E* frame set in position on the landward side of the tower, while two of the boys are climbing out on the opposite *B* and *C* frames preparatory to setting up the other *E* frame. A cross stick was now bolted to each *D* frame, just beyond the upper ends of the *E* sticks. This done, the frame *F* was hooked in between the ends of *B* and *C*, at the shoreward side of the tower, and its outer ends were supported by frame *G*, which was hooked over frame *D* and the upper ends of frame *E*. The frame *L* was then rested on the ends of frame *F* and *G*, and supported the shore end of frame *D*. A stick nailed across frame *D* on each side of the upper ends of frame *L* served to hold the latter in place.

Binding and Anchoring the Structure.



Fig. 319. Preparing to Put an E Frame in Place.

As the different frames were coupled together, we bound the overlapping ends with soft iron wire. The place where frames *B*, *C*, *E* and *F* came together was quite a vital point, and we took pains to make the wire binding at this place doubly strong. As soon as the *L* frame was in place we anchored the bridge to shore by running wires from the ends of the *D* frame and the ends of the *G* frame to stakes driven into the banks. The frames on the second tower were now similarly erected and anchored, after which we were ready to put in the center panels of the bridge.

The Center Panels of the Bridge.

First, the frame *H* was wedged into place and thoroughly fastened by a liberal winding of wire. Next the frames *I* and *J* were set in place, and in order to do this we had to remove the upper tie pieces of these frames. Then one frame was hooked in the other, and the two were carried out on the scow under the center of the bridge. Ropes were tied to the ends of the two frames, and they were lifted together, like a wide *V*, to the position shown in Fig. 318, after which the tie pieces were bolted on again, resting against the ends of the *E* frames. As an additional security, two sticks were bolted to the under side of the frame *H*, one at each side of the *I* and *J* frames. The bridge was then completed by wedging the frame *K* under the ends of the *D* frames, and also placing a stick across each tower under the joints of the *D* frames. We planned to run our gravity railway across this bridge, moving our platform and trestle to the opposite bank; so instead of flooring our bridge with slabs, we fastened ties across at intervals of 15 or 18 inches. These ties were sticks 3 inches in diameter, which were secured to the *D* frames.

A Serious Interruption.

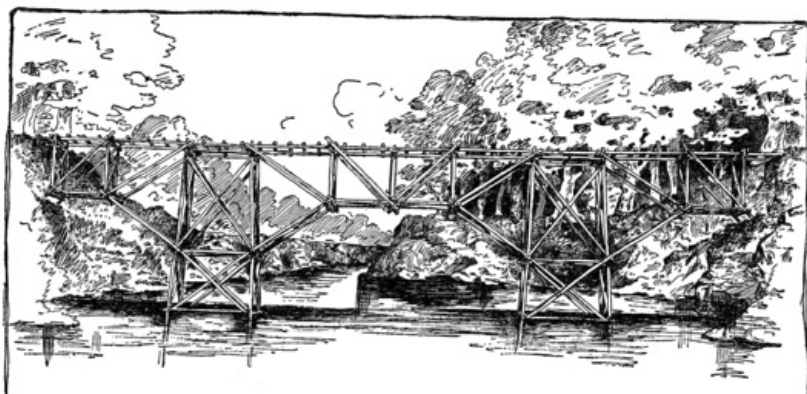

Fig. 320. A General View of our Cantilever Bridge.

We were just preparing to lay the tracks across the bridge when we met with a serious interruption. Mr. Halliday had told us that a few days before our arrival that summer Mr. Smith, the owner of the island, and another man had paid a visit to the place. Jim Halliday himself had rowed them over, and learned from their conversation that Mr. Smith was trying to sell the island, and that the stranger, a Mr. Gill, was a prospective purchaser. All summer long we had been dreading the return of this customer, though, as time passed without his putting in an appearance, we almost forgot the incident. But now, at the end of August, just as we had about completed our cantilever bridge, who should arrive but this very man Gill and three other men with a large tent and camping outfit. It was a sorrowful crowd of boys that watched the wagon with their belongings ford the shallow water over to our island. We felt that the island was ours by right of discovery and occupation, but we were powerless to force our claims. And what if they did not insist on our leaving the island? It would not be the same place with strangers around to meddle with our things.

Dispossessed.

But the new owner of the island was even more of a boor than we had anticipated. As soon as he landed he wanted to know what we were doing on his property, and peremptorily ordered us off. Bill answered that we were camping there, and politely asked if we couldn't stay out the summer. But Gill would not listen to the idea. We must get off the island that very day or he would see to it

that we did.

I tell you it made us boil. We were just itching to give the pompous little man the sound thrashing he deserved, but knew that we would stand a very small show against his three powerful companions. At any rate, we were determined not to leave at once. Instead, we repaired to Kite Island, taking our belongings with us. Then we cut away the suspension, spar and pontoon bridges, so that we would not be annoyed by any of the Gill crowd. We were resolved that they should not benefit by any of the things we had built.

307

At the dead of night we paddled back to Willow Clump Island, crept past the slumbering intruders and waded out to the old water wheel. After a good deal of exertion we managed to dislodge the smaller tower, letting the wheel drop into the river and float away. Then we made for the cantilever bridge. It didn't take us very long to cut away the wire bindings, unhook the frames and drop them into the lagoon. But the task was quite a perilous one, as the night was pitch black. Finally, nothing remained of the bridge but the two towers, which were left as monuments to mark the spot where our last piece of engineering on the island was done.



Building the Cantilever Bridge over Cedar Brook.

Farewell to Willow Clump Island.

We spent several days on Kite Island, knowing that we were safe from intrusion, because the Gill crowd had but one boat, and that was on the Jersey side of the island. We felt confident that they would not take the trouble of wading around Point Lookout with their boats, as we had done; nevertheless, to prevent a surprise, we kept a sentry posted on the Lake Placid side of the island and gathered a pile of stones for ammunition. But our fun was spoiled, and we finally decided to break camp and bid farewell forever to Willow Clump Island and its vicinity. Our goods were ferried over to Jim Halliday's farm, where we were given shelter. The windmill, as I have already stated, was sold to a farmer at Lumberville, and we were kept busy for several days carting it over and setting it up in place. When everything had been done we stole back to Kite Island and set fire to the log cabin. The next day Mr. Schreiner took us home in a couple of his wagons. Thus ended our "investigation, exploration and exploitation of Willow Clump Island." The work of two summers was practically all destroyed in a few days.

308

Reddy's Cantilever Bridge.

I believe I have given a careful account of everything that was recorded in the chronicles of the society. We were too discouraged to undertake anything new in the two weeks before school opened. I presume I might mention here Reddy's cantilever bridge, which, however, had really nothing to do with the S. S. I. E. E. of W. C. I., because our society was formally disbanded the day before Bill and I returned to school. About a month after leaving home I received a letter from Reddy inclosing three interesting photographs, which are reproduced herewith. Reddy certainly had the bridge fever, because soon after we had left he started to work, with the rest of the boys, on a cantilever bridge across Cedar Brook. The brook was entirely unsuited to such a structure, because the banks were very low; but he made the towers quite short and built an inclined roadway leading up to the top of them. The legs of the towers were driven firmly into the bank, making them so solid that he thought it would be perfectly safe to build the frames out over the brook without building them at the same time on the shore side. But he had made a miscalculation, for when a couple of the boys had crawled out on the *B* and *C* frames to set up an *E* frame the structure commenced to sag. The trouble was remedied by propping up the tower with a stout stick driven into the river bottom and wedged under the upper tie piece of the tower. The towers were really too short to make a well proportioned bridge, for the panels had to be made very long and narrow, so as to reach across. But on the whole it was a very creditable structure when completed, though it had only half as long a span as our cantilever bridge over the lagoon.

309

A

"A" tent, [207](#)
Abbreviations, wigwag, [146](#)
Accident, railway, the first, [290](#)
Ainu snow shoe, [41](#)
Alarm clock, a unique, [63](#)
Alphabet, wigwag, [145](#)
Alpine stock, [198](#)
Anchoring cantilever bridge, [303](#)
Annex, the, [50](#)
Arctic expedition, [193](#)
Armchair, barrel, [227](#)
Axles of railroad car, [285](#)

B

Bags, sleeping, [203](#)
Banquets, midnight, [179](#)
Barrel armchair, [227](#)
Barrel filter, [68](#)
Barrel hoop snow shoe, [36](#)
Barrel stave hammock, [226](#)
Barrel stave snow shoe, [36](#)
Bat's wings, [33](#)
Bed, a camp, [209](#)
Bed in shower, [210](#)
Belly band, elastic, [235](#)
Bending wood, [39](#)
Bicycle wheels, mounting frame on, [219](#)
Big Bug Club, [177](#)
"Bill," [17](#)
Bill's cave, [224](#)
Bill's skate sail, [21](#)
Binding cantilever bridge, [303](#)
Blades of wind wheel, [278](#)
Boat, ice, [159](#)
Boat mooring, tramp-proof, [142](#)
Boat, scow, [59](#)
Box kite, diamond, [236](#)
Box, the black walnut, [19](#)
Brake for wind wheel, [278](#)
Bridge building, [95](#)
Bridge, cantilever, [292](#)
Bridge, king post, [105](#)
Bridge, king rod, [102](#)
Bridge, pontoon, [101](#)
Bridge, Reddy's cantilever, [308](#)
Bridge, spar, [95](#)
Bridge, stiffening, [104](#)
Bridge, suspension, [99](#)
Bridge wreck, [66](#)
Bucket, the canvas, [251](#)
Buckets for water wheel, [246](#)
Bunks, [270](#)

C

Camp bed, [209](#)
Camp bed in shower, [210](#)
Camp, breaking, [158](#)
Camp chair, a, [208](#)
Camp fire, a costly, [200](#)
Camp fire, kindling, [194](#)
Canoe, Indian paddling, [121](#)
Canoe lee boards, [119](#)
Canoe rudder, [115](#)
Canoe, the sailing, [111](#)
Canoe sails, [117](#)
Canoe, scooter, [190](#)
Canoe, stretching on canvas, [114](#)
Canoes, canvas, [109](#)
Cantilever bridge, [292](#)
Cantilever bridge, anchoring, [303](#)
Cantilever bridge, binding frames, [303](#)
Cantilever bridge, center panels, [304](#)
Cantilever bridge, frames for, [293](#)
Cantilever bridge, Reddy's, [308](#)
Cantilever bridge, setting up frames of, [300](#)
Cantilever bridge towers, [299](#)
Canvas bucket, [251](#)
Canvas canoes, [109](#)
Canvas, stretching on canoe, [114](#)
Canvas tent, [46](#)
Car axles, [285](#)

Car for gravity railroad, [284](#)
Car, mounting wheels on, [286](#)
Carpenter's miter box, [288](#)
Cave, Bill's, [224](#)
Cave, covering the, [177](#)
Cave, excavating for, [173](#)
Cave, framing, [174](#)
Cave-in, a, [171](#)
Center panels of cantilever bridge, [304](#)
Chain, surveyor's, [77](#)
Chair, a camp, [208](#)
Chair seat snow shoe, [35](#)
Cheek blocks, [162](#)
Chinks in log cabin, stopping up, [272](#)
Christmas vacation, [19](#)
Clamp for crank shaft, [276](#)
Clapboards, nailing on, [135](#)
Cleat, a, [163](#)
Climbing, mountain, [198](#)
Clock, a unique alarm, [63](#)
Club, the Big Bug, [177](#)
Club pin, [180](#)
Club, the Subterranean, [171](#)
Code, International Telegraph, [155](#)
Combination lock, [181](#)
Council of war, [139](#)
Crank shaft, the, [276](#)
Creepers, ice, [170](#)
Crossbow, [55](#)
Crossbow trigger, [57](#)
Cutting out disk, [78](#)

D

Danish sail, [30](#)
Derrick, the, [131](#)
Diamond box kite, [236](#)
Digging the well, [274](#)
Disk, cutting out, [78](#)
Disk, sighting, [79](#)
Dispossessed, [306](#)
Diving tree, [84](#)
Door hinges, [269](#)
Door latch, [269](#)
Doors, sliding, [136](#)
Double mirror heliograph, [156](#)
Double surprise, [140](#)
Drill, fire, [69](#)
Drowned, how to restore, alone, [92](#)
Drowned, restoring the, [89](#)

E

Easter vacation, [224](#)
Elastic belly band, [235](#)
Expedition, Arctic, [193](#)
Expedition, logging, [255](#)
Expedition, preparing for, [53](#)
Exploration, preliminary, [66](#)

F

Farewell to Willow Clump Island, [307](#)
Fastener, brass, [58](#)
Filter, the barrel, [68](#)
Filter barrel, cooling the, [250](#)
Filter, the small, [67](#)
Fire drill, [69](#)
Fireplace of log cabin, [265](#)
Fireplace, outdoor, [195](#)
Fireplace, stone-paved, [196](#)
Fissure, path up the, [129](#)
Flanged wheels, [285](#)
Fly, ridge pole, [54](#)
Fly for tent, [54](#)
Fly, umbrella with, [211](#)
Focusing heliograph instrument, [153](#)
Frame on bicycle wheels, [219](#)
Frames for cantilever bridge, [293](#)
Frames of cantilever bridge, setting up, [300](#)
Friend in time of trouble, [201](#)

G

Goblins' Dancing Platform, [126](#)
Grass hut, [124](#)
Gravity railroad, [283](#)

H

Halliday, Jim, [194](#)
Hammock, barrel stave, [226](#)
Harness, pack, [212](#)
Heliograph, the, [147](#)
Heliograph, double mirror, [156](#)
Heliograph instrument, focusing, [153](#)
Heliograph screen, [151](#)
Heliograph sight rod, [150](#)
Heliograph signaling, [154](#)
Heliograph, single mirror, [148](#)
Hinge for spars, [30](#)
Hinges, door, [269](#)
House building, [124](#)
House, log, [254](#)
House, the tree, [132](#)
Hut, cold night in, [197](#)
Hut, log, [254](#)
Hut, straw, [124](#)

I

Ice boat, the, [159](#)
Ice boats, sledges and toboggans, [158](#)
Ice, craft strikes the, [184](#)
Ice creepers, [170](#)
Indian paddling canoe, [121](#)
Instrument, double mirror, [156](#)
Instrument, single mirror, [148](#)
Instrument, surveying, [73](#)
International Telegraph Code, [155](#)
Iroquois snow shoe, [39](#)
Island, mapping the, [82](#)
Island, off to the, [63](#)
Island, trip to the, [64](#)

J

Jacob's Ladder, [129](#)
Jaws of boom, [162](#)
Jib-sail for ice boat, [164](#)
Jib-sail for scooter scow, [187](#)
Jim Halliday, [194](#)

K

King post bridge, [105](#)
King rod truss, [102](#)
Kite, diamond box, [236](#)
Kite Island, [83](#)
Kite, Malay, 5-foot, [231](#)
Kite, Malay, 8-foot, [233](#)
Kites, putting to work, [235](#)
Kites, tailless, [229](#)
Klepalo, the, [70](#)

L

Ladder, the Jacob's, [129](#)
Ladders, rope, [130](#)
Lagoon, the, [83](#)
Lake Placid, [83](#)
Land yacht, [215](#)
Land yacht, a sail on, [222](#)
Lanteen sail for canoe, [117](#)
Lanteen skate sail, [29](#)
Latch, door, [269](#)
Latch string, [270](#)
Lee boards, canoe, [119](#)
"Leg-of-mutton" sail, [220](#)
Levels, spirit, [74](#)
Lock combination, [181](#)
Log cabin, [251](#)
Log cabin, building the, [259](#)
Log cabin door hinges, [269](#)
Log cabin door latch, [269](#)
Log cabin door and window frames, [263](#)
Log cabin fireplace, [265](#)
Log cabin, floor of, [267](#)
Log cabin, foundation of, [254](#)
Log cabin, roof of, [262](#)
Log cabin, stopping up chinks, [272](#)
Log cabin window sash, [270](#)
Log raft, [256](#)
Logging expedition, [255](#)

M

Mainsail for canoe, [117](#)
Mainsail for ice boat, [162](#)
Malay kite, 5-foot, [231](#)
Malay kite, 8-foot, [233](#)
Mapping the island, [82](#)
Mast of land yacht, stepping, [218](#)
Mast step, ice boat, [161](#)
Mast step, leather, [30](#)
Mast step, wooden, [30](#)
Megaphone, [57](#)
Megaphone mouthpiece, [58](#)
Midnight banquets, [179](#)
Mill-race, the, [88](#)
Mirror instrument, heliograph, [148](#)
Miter box, carpenter's, [288](#)
Mizzen sail of canoe, [118](#)
Mooring, tramp-proof boat, [142](#)
Mountain climbing, [198](#)
Mouthpiece of megaphone, [58](#)
"Mummy case," [204](#)

N

Needle, weaving, [39](#)
Night, cold, in the hut, [197](#)
Nightmare, a, [211](#)
Noria, [241](#)
Norwegian ski, [42](#)
Numerals, wigwag, [145](#)

O

Oar, the, [61](#)
Off to the island, [63](#)
Organizing the society, [25](#)
Outdoor fireplace, [195](#)
Outfits, tramping, [203](#)

P

Pack harness, [212](#)
Paddling canoe, Indian, [121](#)
Paddles for water wheel, [246](#)
Panels, center, of cantilever bridge, [304](#)
Path up the fissure, [129](#)
Patient, how to work over, alone, [93](#)
Pin, the club, [180](#)
Plank, swimming on, [86](#)
Platform, Goblins' Dancing, [126](#)
Point Lookout, [83](#)
Pole, ridge, [48](#)
Poncho, [210](#)
Pontoon bridge, [101](#)
Poor shelter, a, [199](#)
Preparing for the expedition, [53](#)
Protractor, the, [76](#)
Provisions and supplies, [54](#)
Pump, the, [279](#)
Pump, action of, [281](#)
Pump valves, the, [280](#)

R

Raft, log, [256](#)
Raft, sail-rigged, [258](#)
Railroad car, [284](#)
Railroad car axles, [285](#)
Railroad flanged wheels, [285](#)
Railroad, gravity, [283](#)
Railway track, the, [287](#)
Railway accident, the first, [290](#)
Railway, rope, [97](#)
Railway spikes, [50](#)
Rapids, shooting the, [88](#)
Receiving trough for water wheel, [247](#)
Records of the S. S. I. E. E. of W. C. I., [19](#)
Reddy's cantilever bridge, [308](#)
Rennwolf, the, [168](#)
Restoring the drowned, [89](#)
Ridge pole, [48](#)
Ridge pole, fly, [54](#)
Riveting, [213](#)
Rod, heliograph sight, [150](#)
Rod, surveyor's, [78](#)
Rope ladders, [130](#)

Rope railway, 97
Rowlocks, sockets for, 60
Rudder, canoe, 115
Rudder shoe, ice boat, 160
Runner shoe, ice boat, 160
Runners of scooter canoe, 190
Runners of sledge, 165
Rustic table, 66

S

S. S. I. E. E. of W. C. I., records of, 19
Sail, jib, for scooter, 187
Sail, "leg-of-mutton," 220
Sail, mizzen, of canoe, 118
Sail-rigged raft, 258
Sail, sprit, for scooter, 186
Sail stitch, 46
Sail through the country, 222
Sailing canoe, the, 111
Sailor's stitch, 221
Sails, canoe, 117
Sails for ice boat, 162
Sandwiches, straw, 227
Schreiner, a visit from Mr., 110
Scooter canoe, 190
Scooter sailing, 188
Scooter scow, 185
Scooters, 183
Scow, the, 59
Scow, a sail in, 184
Scow, scooter, 185
Scow, stolen, 138
Screen, heliograph, 151
Seat, swing, 97
Shaft, the crank, 276
Shelter, a poor, 199
Shooting the rapids, 88
Sight rod, 150
Sighting blocks, 74
Sighting disk, 79
Signaling, heliograph, 154
Signals, wigwag, 144
Simple method of surveying, 79
Single mirror heliograph, 148
Sioux snow shoe, 37
Skate sail, bat's wings, 33
Skate sail, Bill's, 21
Skate sail, Danish, 30
Skate sail, double Swedish, 26
Skate sail, lanteen, 29
Skate sail, single Swedish, 28
Skate sails, 26
Ski, Norwegian, 42
Ski sticks, 43
Skids, 262
Slabs, 101
Sledge, the, 165
Sleeping bags, 203
Sliding doors, 136
Snotter, 187
Snow shoe, Ainu, 41
Snow shoe, barrel hoop, 36
Snow shoe, barrel stave, 36
Snow shoe, chair seat, 35
Snow shoe, Iroquois, 39
Snow shoe, Sioux, 37
Snow shoe, Swiss, 43
Snow shoes, 35
Society, meeting of, 189
Society, organizing the, 25
Spar bridge, 95
Spars, hinge for, 30
Spikes, railway, 50
Spiral spring, 153
Spirit levels, 74
Spring, spiral, 153
Sprit sail, 186
Stepping mast of land yacht, 218
Stitch, the sail, 46
Stitch, sailor's, 221
Stick, ski, 43
Stiffening the bridge, 104
Stone-paved fireplace, 196

Stone wall, how to build, [266](#)
Straw hut, [124](#)
Straw sandwiches, [227](#)
Subterranean Club, [171](#)
Summer toboggan, [229](#)
Supplies and provisions, [54](#)
Surprise, a double, [140](#)
Surveying, [73](#)
Surveying, first lesson in, [79](#)
Surveying instrument, [73](#)
Surveying, a simple method of, [79](#)
Surveying for water wheel, [241](#)
Surveyor's chain, [77](#)
Surveyor's rod, [78](#)
Suspension bridge, [99](#)
Swamp shoe, [43](#)
Swedish sail, double, [26](#)
Swedish sail, single, [28](#)
Swimming, [84](#)
Swimming on a plank, [86](#)
Swing seat, [97](#)
Swiss snow shoe, [43](#)

T

Table, a rustic, [66](#)
Tailless kites, [229](#)
Telegraph Code, International, [155](#)
Tent, the "A", [207](#)
Tent, annex, [50](#)
Tent, canvas wall, [46](#)
Tent fly, [54](#)
Tent making, [44](#)
Testing the track, [291](#)
Thole pins, [61](#)
Tie block, wood, [49](#)
Tie, wire, [50](#)
Tiger's Tail, [83](#)
Tiller, ice boat, [161](#)
Tiller of land yacht, [219](#)
Toboggan, the, [167](#)
Toboggan, the summer, [229](#)
Tower, the windmill, [275](#)
Towers of the cantilever bridge, [299](#)
Towers for water wheel, [243](#)
Towers of water wheel, setting up, [248](#)
Track, laying the, [289](#)
Track, the railway, [287](#)
Track, testing the, [291](#)
Tramping outfits, [203](#)
Tramp-proof boat mooring, [142](#)
Tramps, trouble with, [138](#)
Tree, diving, [84](#)
Tree house, the, [132](#)
Trigger for crossbow, [57](#)
Trip to the island, [64](#)
Tripod, the, [75](#)
Trouble with tramps, [138](#)
Trunk, the old, [18](#)
Truss, king rod, [102](#)
Turnbuckle, a simple, [216](#)

U

Umbrella with fly, [211](#)
Umbrella rib crossbow, [55](#)
Uncle Ed, word from, [45](#)
Uncle Ed's departure, [109](#)

V

Vacation, Christmas, [19](#)
Vacation, Easter, [224](#)
Valves, the pump, [280](#)
Van Syckel, interview with, [189](#)
Vengeance, [139](#)
Visit from Mr. Schreiner, [110](#)

W

Wall, how to build, [266](#)
Wall tent, [46](#)
Water wheel, [241](#)
Water wheel buckets, [246](#)
Water wheel, construction of, [245](#)
Water wheel, Mr. Halliday's, [252](#)
Water wheel, mounting the, [249](#)

Water wheel paddles, [246](#)
Water wheel receiving trough, [247](#)
Water wheel, surveying for, [241](#)
Water wheel, towers for, [243](#)
Water wheel towers, setting up, [248](#)
War, council of, [139](#)
Weaving needle, [39](#)
Well, digging the, [274](#)
Wheel, the wind, [276](#)
Wheels for gravity railroad, [285](#)
Wheels, mounting, on car, [286](#)
Wheels, mounting frame on, [219](#)
Wigwag abbreviations, [146](#)
Wigwag alphabet, [145](#)
Wigwag numerals, [145](#)
Wigwag signals, [144](#)
Wigwagging and heliographing, [144](#)
Wigwagging at night, [147](#)
Willow Clump Island, [23](#)
Willow Clump Island, farewell to, [307](#)
Willow Clump Island in winter, [194](#)
Wind wheel, [276](#)
Wind wheel blades, [278](#)
Wind wheel brake, [278](#)
Windmill, [273](#)
Windmill tower, [275](#)
Window hinge, [270](#)
Window sash, log cabin, [270](#)
Wings, bat's, [33](#)
Wire tie, [50](#)
Wood, bending, [39](#)
Wood tie block, [49](#)
Word from Uncle Ed, [45](#)

Y

Yacht, land, [215](#)
Yacht, land, frame of, [216](#)

The Most Popular Scientific Paper in the World



Established 1845
Weekly, \$3.00 a Year; \$1.50 Six Months

This unrivaled periodical is now in its *sixtieth year*, and, owing to its ever-increasing popularity, it enjoys the largest circulation ever attained by any scientific publication. Every number contains sixteen large pages, beautifully printed, handsomely illustrated; it presents in popular style a descriptive record of the most novel, interesting and important developments in Science, Arts and Manufactures. It shows the progress of the World in respect to New Discoveries and Improvements, embracing Machinery, Mechanical Works, Engineering in all its branches, Chemistry, Metallurgy, Electricity, Light, Heat, Architecture, Domestic Economy, Agriculture, Natural History, etc. It abounds in fresh and interesting subjects for discussion, thought or study. To the inventor it is invaluable, as every number contains a complete list of all patents and trademarks issued weekly from the Patent Office. It promotes Industry, Progress, Thrift and Intelligence in every community where it circulates.

The SCIENTIFIC AMERICAN should have a place in every Dwelling, Shop, Office, School, or Library. Workmen, Foremen, Engineers, Superintendents, Directors, Presidents, Officials, Merchants, Farmers, Teachers, Lawyers, Physicians, Clergymen—people in every walk and profession in life—will derive satisfaction and benefit from a regular reading of the SCIENTIFIC AMERICAN.

If you want to know more about the paper send for "*Fifteen Reasons Why You Should Subscribe to the Scientific American*," and for "*Five Reasons Why Inventors Should Subscribe to the Scientific American*." Fifty-two numbers make 832 large pages, equal to 3,328 ordinary magazine pages, and 1,000 illustrations are published each year. Can you and your friends afford to be without this up-to-date periodical, which is read by every class and profession? Remit \$3.00 by postal order or check for a year's subscription, or \$1.50 for six months.

MUNN & COMPANY, Publishers
No. 361 Broadway, New York City

JUST PUBLISHED

Home Mechanics for Amateurs

By GEORGE M. HOPKINS

Author of "Experimental Science"

12mo, 375 Pages, 320 Illustrations. Price, \$1.50, Postpaid

The book deals with wood-working, household ornaments, metal-working, lathe work, metal spinning, silver working; making model engines, boilers and water motors; making telescopes, microscopes and meteorological instruments, electrical chimes, cabinets, bells, night lights, dynamos and motors, electric light, and an electrical furnace. It is a thoroughly practical book by the most noted amateur experimenter in America.

Every reader of "Experimental Science" should possess a copy of this most helpful book. It appeals to the boy as well as the more mature amateur. Holidays and evenings can be profitably occupied by making useful articles for the home or in building small engines or motors or scientific instruments. Table of contents sent on application.

MUNN & COMPANY

Publishers of the "Scientific American"

361 BROADWAY, NEW YORK

Scientific American Reference Book

500 PAGES SIX COLORED PLATES PRICE \$1.50

This book is intended to furnish the reader with information not obtainable in any other work of reference. It is not an encyclopedia, nor is it an annual, but it contains a mass of information that should be within the reach of every family. This work has been prepared in response to the many thousands of inquiries received by the Editor of the SCIENTIFIC AMERICAN on the widest possible range of topics, and it is through these inquiries that the Editors of the REFERENCE BOOK have been enabled to determine the scope of this work. It deals with the "Progress of Discovery," "Shipping and Yachts," "The Navies of the World," "The Armies of the World," "Railroads of the World," "Population," "Education," "Telegraphs," "Submarine Telegraphs," "Wireless Telegraphy," "Patents," "Trade-marks," "Copyrights," "Manufactures," "Iron and Steel," "Departments of the Federal Government," "The Post-office," "International Institutions and Bureaus," "Mines and Mining," "Farms and Food," "Mechanical Movements," "Chemistry," "Astronomy," "Weights and Measures," and a host of other subjects, such as "Aerial Navigation," "Radium," etc. This valuable compendium has been put at a very low price, so that it may be within the reach of every one. It is fully illustrated, and has colored plates showing the flags of all nations, the funnels and house flags of lines in American trade, and the International Signal Code.

DESCRIPTIVE CIRCULAR SENT UPON REQUEST

MUNN & COMPANY, Publishers

361 BROADWAY :: :: NEW YORK CITY

*** END OF THE PROJECT GUTENBERG EBOOK THE SCIENTIFIC AMERICAN BOY; OR, THE
CAMP AT WILLOW CLUMP ISLAND ***

Updated editions will replace the previous one—the old editions will be renamed.

Creating the works from print editions not protected by U.S. copyright law means that no one owns a United States copyright in these works, so the Foundation (and you!) can copy and

distribute it in the United States without permission and without paying copyright royalties. Special rules, set forth in the General Terms of Use part of this license, apply to copying and distributing Project Gutenberg™ electronic works to protect the PROJECT GUTENBERG™ concept and trademark. Project Gutenberg is a registered trademark, and may not be used if you charge for an eBook, except by following the terms of the trademark license, including paying royalties for use of the Project Gutenberg trademark. If you do not charge anything for copies of this eBook, complying with the trademark license is very easy. You may use this eBook for nearly any purpose such as creation of derivative works, reports, performances and research. Project Gutenberg eBooks may be modified and printed and given away—you may do practically ANYTHING in the United States with eBooks not protected by U.S. copyright law. Redistribution is subject to the trademark license, especially commercial redistribution.

START: FULL LICENSE
THE FULL PROJECT GUTENBERG LICENSE
PLEASE READ THIS BEFORE YOU DISTRIBUTE OR USE THIS WORK

To protect the Project Gutenberg™ mission of promoting the free distribution of electronic works, by using or distributing this work (or any other work associated in any way with the phrase “Project Gutenberg”), you agree to comply with all the terms of the Full Project Gutenberg™ License available with this file or online at www.gutenberg.org/license.

Section 1. General Terms of Use and Redistributing Project Gutenberg™ electronic works

1.A. By reading or using any part of this Project Gutenberg™ electronic work, you indicate that you have read, understand, agree to and accept all the terms of this license and intellectual property (trademark/copyright) agreement. If you do not agree to abide by all the terms of this agreement, you must cease using and return or destroy all copies of Project Gutenberg™ electronic works in your possession. If you paid a fee for obtaining a copy of or access to a Project Gutenberg™ electronic work and you do not agree to be bound by the terms of this agreement, you may obtain a refund from the person or entity to whom you paid the fee as set forth in paragraph 1.E.8.

1.B. “Project Gutenberg” is a registered trademark. It may only be used on or associated in any way with an electronic work by people who agree to be bound by the terms of this agreement. There are a few things that you can do with most Project Gutenberg™ electronic works even without complying with the full terms of this agreement. See paragraph 1.C below. There are a lot of things you can do with Project Gutenberg™ electronic works if you follow the terms of this agreement and help preserve free future access to Project Gutenberg™ electronic works. See paragraph 1.E below.

1.C. The Project Gutenberg Literary Archive Foundation (“the Foundation” or PGLAF), owns a compilation copyright in the collection of Project Gutenberg™ electronic works. Nearly all the individual works in the collection are in the public domain in the United States. If an individual work is unprotected by copyright law in the United States and you are located in the United States, we do not claim a right to prevent you from copying, distributing, performing, displaying or creating derivative works based on the work as long as all references to Project Gutenberg are removed. Of course, we hope that you will support the Project Gutenberg™ mission of promoting free access to electronic works by freely sharing Project Gutenberg™ works in compliance with the terms of this agreement for keeping the Project Gutenberg™ name associated with the work. You can easily comply with the terms of this agreement by keeping this work in the same format with its attached full Project Gutenberg™ License when you share it without charge with others.

1.D. The copyright laws of the place where you are located also govern what you can do with this work. Copyright laws in most countries are in a constant state of change. If you are outside the United States, check the laws of your country in addition to the terms of this agreement before downloading, copying, displaying, performing, distributing or creating derivative works based on this work or any other Project Gutenberg™ work. The Foundation makes no representations concerning the copyright status of any work in any country other than the United States.

1.E. Unless you have removed all references to Project Gutenberg:

1.E.1. The following sentence, with active links to, or other immediate access to, the full Project Gutenberg™ License must appear prominently whenever any copy of a Project Gutenberg™ work (any work on which the phrase “Project Gutenberg” appears, or with which the phrase “Project Gutenberg” is associated) is accessed, displayed, performed, viewed, copied or distributed:

This eBook is for the use of anyone anywhere in the United States and most other parts of the world at no cost and with almost no restrictions whatsoever. You may copy it, give it away or re-use it under the terms of the Project Gutenberg License included with this eBook or online at www.gutenberg.org. If you are not located in the United States, you will have to check the laws of the country where you are

located before using this eBook.

1.E.2. If an individual Project Gutenberg™ electronic work is derived from texts not protected by U.S. copyright law (does not contain a notice indicating that it is posted with permission of the copyright holder), the work can be copied and distributed to anyone in the United States without paying any fees or charges. If you are redistributing or providing access to a work with the phrase “Project Gutenberg” associated with or appearing on the work, you must comply either with the requirements of paragraphs 1.E.1 through 1.E.7 or obtain permission for the use of the work and the Project Gutenberg™ trademark as set forth in paragraphs 1.E.8 or 1.E.9.

1.E.3. If an individual Project Gutenberg™ electronic work is posted with the permission of the copyright holder, your use and distribution must comply with both paragraphs 1.E.1 through 1.E.7 and any additional terms imposed by the copyright holder. Additional terms will be linked to the Project Gutenberg™ License for all works posted with the permission of the copyright holder found at the beginning of this work.

1.E.4. Do not unlink or detach or remove the full Project Gutenberg™ License terms from this work, or any files containing a part of this work or any other work associated with Project Gutenberg™.

1.E.5. Do not copy, display, perform, distribute or redistribute this electronic work, or any part of this electronic work, without prominently displaying the sentence set forth in paragraph 1.E.1 with active links or immediate access to the full terms of the Project Gutenberg™ License.

1.E.6. You may convert to and distribute this work in any binary, compressed, marked up, nonproprietary or proprietary form, including any word processing or hypertext form. However, if you provide access to or distribute copies of a Project Gutenberg™ work in a format other than “Plain Vanilla ASCII” or other format used in the official version posted on the official Project Gutenberg™ website (www.gutenberg.org), you must, at no additional cost, fee or expense to the user, provide a copy, a means of exporting a copy, or a means of obtaining a copy upon request, of the work in its original “Plain Vanilla ASCII” or other form. Any alternate format must include the full Project Gutenberg™ License as specified in paragraph 1.E.1.

1.E.7. Do not charge a fee for access to, viewing, displaying, performing, copying or distributing any Project Gutenberg™ works unless you comply with paragraph 1.E.8 or 1.E.9.

1.E.8. You may charge a reasonable fee for copies of or providing access to or distributing Project Gutenberg™ electronic works provided that:

- You pay a royalty fee of 20% of the gross profits you derive from the use of Project Gutenberg™ works calculated using the method you already use to calculate your applicable taxes. The fee is owed to the owner of the Project Gutenberg™ trademark, but he has agreed to donate royalties under this paragraph to the Project Gutenberg Literary Archive Foundation. Royalty payments must be paid within 60 days following each date on which you prepare (or are legally required to prepare) your periodic tax returns. Royalty payments should be clearly marked as such and sent to the Project Gutenberg Literary Archive Foundation at the address specified in Section 4, “Information about donations to the Project Gutenberg Literary Archive Foundation.”
- You provide a full refund of any money paid by a user who notifies you in writing (or by e-mail) within 30 days of receipt that s/he does not agree to the terms of the full Project Gutenberg™ License. You must require such a user to return or destroy all copies of the works possessed in a physical medium and discontinue all use of and all access to other copies of Project Gutenberg™ works.
- You provide, in accordance with paragraph 1.F.3, a full refund of any money paid for a work or a replacement copy, if a defect in the electronic work is discovered and reported to you within 90 days of receipt of the work.
- You comply with all other terms of this agreement for free distribution of Project Gutenberg™ works.

1.E.9. If you wish to charge a fee or distribute a Project Gutenberg™ electronic work or group of works on different terms than are set forth in this agreement, you must obtain permission in writing from the Project Gutenberg Literary Archive Foundation, the manager of the Project Gutenberg™ trademark. Contact the Foundation as set forth in Section 3 below.

1.F.

1.F.1. Project Gutenberg volunteers and employees expend considerable effort to identify, do copyright research on, transcribe and proofread works not protected by U.S. copyright law in creating the Project Gutenberg™ collection. Despite these efforts, Project Gutenberg™ electronic works, and the medium on which they may be stored, may contain “Defects,” such

as, but not limited to, incomplete, inaccurate or corrupt data, transcription errors, a copyright or other intellectual property infringement, a defective or damaged disk or other medium, a computer virus, or computer codes that damage or cannot be read by your equipment.

1.F.2. LIMITED WARRANTY, DISCLAIMER OF DAMAGES - Except for the “Right of Replacement or Refund” described in paragraph 1.F.3, the Project Gutenberg Literary Archive Foundation, the owner of the Project Gutenberg™ trademark, and any other party distributing a Project Gutenberg™ electronic work under this agreement, disclaim all liability to you for damages, costs and expenses, including legal fees. YOU AGREE THAT YOU HAVE NO REMEDIES FOR NEGLIGENCE, STRICT LIABILITY, BREACH OF WARRANTY OR BREACH OF CONTRACT EXCEPT THOSE PROVIDED IN PARAGRAPH 1.F.3. YOU AGREE THAT THE FOUNDATION, THE TRADEMARK OWNER, AND ANY DISTRIBUTOR UNDER THIS AGREEMENT WILL NOT BE LIABLE TO YOU FOR ACTUAL, DIRECT, INDIRECT, CONSEQUENTIAL, PUNITIVE OR INCIDENTAL DAMAGES EVEN IF YOU GIVE NOTICE OF THE POSSIBILITY OF SUCH DAMAGE.

1.F.3. LIMITED RIGHT OF REPLACEMENT OR REFUND - If you discover a defect in this electronic work within 90 days of receiving it, you can receive a refund of the money (if any) you paid for it by sending a written explanation to the person you received the work from. If you received the work on a physical medium, you must return the medium with your written explanation. The person or entity that provided you with the defective work may elect to provide a replacement copy in lieu of a refund. If you received the work electronically, the person or entity providing it to you may choose to give you a second opportunity to receive the work electronically in lieu of a refund. If the second copy is also defective, you may demand a refund in writing without further opportunities to fix the problem.

1.F.4. Except for the limited right of replacement or refund set forth in paragraph 1.F.3, this work is provided to you ‘AS-IS’, WITH NO OTHER WARRANTIES OF ANY KIND, EXPRESS OR IMPLIED, INCLUDING BUT NOT LIMITED TO WARRANTIES OF MERCHANTABILITY OR FITNESS FOR ANY PURPOSE.

1.F.5. Some states do not allow disclaimers of certain implied warranties or the exclusion or limitation of certain types of damages. If any disclaimer or limitation set forth in this agreement violates the law of the state applicable to this agreement, the agreement shall be interpreted to make the maximum disclaimer or limitation permitted by the applicable state law. The invalidity or unenforceability of any provision of this agreement shall not void the remaining provisions.

1.F.6. INDEMNITY - You agree to indemnify and hold the Foundation, the trademark owner, any agent or employee of the Foundation, anyone providing copies of Project Gutenberg™ electronic works in accordance with this agreement, and any volunteers associated with the production, promotion and distribution of Project Gutenberg™ electronic works, harmless from all liability, costs and expenses, including legal fees, that arise directly or indirectly from any of the following which you do or cause to occur: (a) distribution of this or any Project Gutenberg™ work, (b) alteration, modification, or additions or deletions to any Project Gutenberg™ work, and (c) any Defect you cause.

Section 2. Information about the Mission of Project Gutenberg™

Project Gutenberg™ is synonymous with the free distribution of electronic works in formats readable by the widest variety of computers including obsolete, old, middle-aged and new computers. It exists because of the efforts of hundreds of volunteers and donations from people in all walks of life.

Volunteers and financial support to provide volunteers with the assistance they need are critical to reaching Project Gutenberg™’s goals and ensuring that the Project Gutenberg™ collection will remain freely available for generations to come. In 2001, the Project Gutenberg Literary Archive Foundation was created to provide a secure and permanent future for Project Gutenberg™ and future generations. To learn more about the Project Gutenberg Literary Archive Foundation and how your efforts and donations can help, see Sections 3 and 4 and the Foundation information page at www.gutenberg.org.

Section 3. Information about the Project Gutenberg Literary Archive Foundation

The Project Gutenberg Literary Archive Foundation is a non-profit 501(c)(3) educational corporation organized under the laws of the state of Mississippi and granted tax exempt status by the Internal Revenue Service. The Foundation’s EIN or federal tax identification number is 64-6221541. Contributions to the Project Gutenberg Literary Archive Foundation are tax deductible to the full extent permitted by U.S. federal laws and your state’s laws.

The Foundation’s business office is located at 809 North 1500 West, Salt Lake City, UT 84116, (801) 596-1887. Email contact links and up to date contact information can be found at the Foundation’s website and official page at www.gutenberg.org/contact

Section 4. Information about Donations to the Project Gutenberg Literary Archive Foundation

Project Gutenberg™ depends upon and cannot survive without widespread public support and donations to carry out its mission of increasing the number of public domain and licensed works that can be freely distributed in machine-readable form accessible by the widest array of equipment including outdated equipment. Many small donations (\$1 to \$5,000) are particularly important to maintaining tax exempt status with the IRS.

The Foundation is committed to complying with the laws regulating charities and charitable donations in all 50 states of the United States. Compliance requirements are not uniform and it takes a considerable effort, much paperwork and many fees to meet and keep up with these requirements. We do not solicit donations in locations where we have not received written confirmation of compliance. To SEND DONATIONS or determine the status of compliance for any particular state visit www.gutenberg.org/donate.

While we cannot and do not solicit contributions from states where we have not met the solicitation requirements, we know of no prohibition against accepting unsolicited donations from donors in such states who approach us with offers to donate.

International donations are gratefully accepted, but we cannot make any statements concerning tax treatment of donations received from outside the United States. U.S. laws alone swamp our small staff.

Please check the Project Gutenberg web pages for current donation methods and addresses. Donations are accepted in a number of other ways including checks, online payments and credit card donations. To donate, please visit: www.gutenberg.org/donate

Section 5. General Information About Project Gutenberg™ electronic works

Professor Michael S. Hart was the originator of the Project Gutenberg™ concept of a library of electronic works that could be freely shared with anyone. For forty years, he produced and distributed Project Gutenberg™ eBooks with only a loose network of volunteer support.

Project Gutenberg™ eBooks are often created from several printed editions, all of which are confirmed as not protected by copyright in the U.S. unless a copyright notice is included. Thus, we do not necessarily keep eBooks in compliance with any particular paper edition.

Most people start at our website which has the main PG search facility: www.gutenberg.org.

This website includes information about Project Gutenberg™, including how to make donations to the Project Gutenberg Literary Archive Foundation, how to help produce our new eBooks, and how to subscribe to our email newsletter to hear about new eBooks.