

**The Project Gutenberg eBook of Scientific American Supplement,
No. 620, November 19,1887, by Various**

This ebook is for the use of anyone anywhere in the United States and most other parts of the world at no cost and with almost no restrictions whatsoever. You may copy it, give it away or re-use it under the terms of the Project Gutenberg License included with this ebook or online at www.gutenberg.org. If you are not located in the United States, you'll have to check the laws of the country where you are located before using this eBook.

Title: Scientific American Supplement, No. 620, November 19,1887

Author: Various

Release date: July 24, 2005 [EBook #16354]
Most recently updated: December 12, 2020

Language: English

Credits: Produced by Juliet Sutherland and the Online Distributed Proofreading Team at www.pgdp.net

*** START OF THE PROJECT GUTENBERG EBOOK SCIENTIFIC AMERICAN
SUPPLEMENT, NO. 620, NOVEMBER 19,1887 ***



Scientific American Supplement, Vol. XXIV., No. 620.
Scientific American, established 1845.

NEW YORK, NOVEMBER 19, 1887.

Scientific American Supplement, \$5 a year.
Scientific American and Supplement, \$7 a year.

**SCIENTIFIC AMERICAN
SUPPLEMENT NO. 620**

NEW YORK, NOVEMBER 19, 1887

Scientific American Supplement. Vol. XXIV., No. 620.

Scientific American established 1845

Scientific American Supplement, \$5 a year.

Scientific American and Supplement, \$7 a year.

TABLE OF CONTENTS.

I.	ARCHITECTURE—Bristol Cathedral—The history and description of this ancient building, with large illustration.—1 illustration.	9904
II.	BIOGRAPHY—Oliver Evans and the Steam Engine.—The work of this early pioneer, hitherto but slightly recognized at his true worth as an inventor.	9896
III.	CHEMISTRY—The Chemistry of the Cotton Fiber—By Dr. BOWMAN—An interesting investigation, showing the variation in composition in different cottons.	9909
	Synthesis of Styrolene.	9910
	Notes on Saccharin.	9910
	Alcohol and Turpentine.	9910
IV.	ENGINEERING—Auguste's Endless Stone Saw—A valuable improvement, introducing the principle of the band saw, and producing a horizontal cut—10 illustrations.	9896

- V. [ELECTRICITY.—A Current Meter—The Jehl & Rupp meter for electricity described—1 illustration.](#) 9903
- [Mix & Genest's Microphone Telephone—The new telephone recently adopted by the imperial post office department of Germany—3 illustrations.](#) 9902
- [Storage Batteries for Electric Locomotion—By A. RECKENZAUN—A valuable paper on this subject, giving historical facts and working figures of expense, etc.](#) 9903
- [The Telemeter System—By R.F. UPTON—The system of Ö.L. Clarke, of New York, as described before the British Association—A valuable tribute to an American inventor—1 illustration.](#) 9900
- VI. [METALLURGY.—The Newbery-Vautin Chlorination Process—A new process of extracting gold from its ores, with details of the management of the process and apparatus—1 illustration.](#) 9907
- VII. [MISCELLANEOUS.—A Gigantic Load of Lumber—The largest barge load of lumber ever shipped—The barge Wahnapiṭæ and her appearance as loaded at Duluth—1 illustration.](#) 9907
- [Apparatus for Exercising the Muscles—An appliance for use by invalids requiring to exercise atrophied limbs—1 illustration.](#) 9908
- [Practical Education.—A plea for the support of manual training schools.](#) 9906
- [Waves—The subject of ocean waves fully treated—An interesting *resume* of our present knowledge of this phenomenon of fluids.](#) 9906
- VIII. [NAVAL ENGINEERING—The New Spanish Armored Cruiser Reina Regente. —Illustration and full description of this recent addition to the Spanish navy.—1 illustration.](#) 9895
- [The Spanish Torpedo Boat Azor—Illustration and note of speed, etc., of this new vessel—1 illustration.](#) 9895
- IX. [OPHTHALMOLOGY—The Bull Optometer—An apparatus for testing the eyesight.—The invention of Dr George J. Bull.—3 illustrations.](#) 9908
- X. [SANITATION AND HYGIENE—The Sanitation of Towns—By J. GORDON, C.E.—A presidential address before the Leicester meeting of the Society of Municipal and Sanitary Engineers and Surveyors of England.](#) 9909
- XI. [TECHNOLOGY—A New Monster Revolving Black Ash Furnace and the Work Done with It—By WATSON SMITH—The great furnace of the Widnes Alkali Company described, with results and features of its working—4 illustrations.](#) 9900
- [Apparatus Used for Making Alcohol for Hospital Use during the Civil War between the States—By CHARLES K. GALLAGHER—A curiosity of war times described and illustrated.—1 illustration.](#) 9900
- [Confederate Apparatus for Manufacturing Saltpeter for Ammunition — By CHARLES K. GALLAGHER—Primitive process for extracting saltpeter from earth and other material—1 illustration.](#) 9900
- [Electrolysis and Refining of Sugar—A method of bleaching sugar said to be due to ozone produced by electric currents acting on the solution—1 illustration.](#) 9903
- [Improvements in the Manufacture of Portland Cement—By FREDERICK RANSOME, A.I.C.E.—An important paper recently read before the British Association, giving the last and most advanced methods of manufacture.](#) 9901
- [Roburite, the New Explosive—Practical tests of this substance, with special application to coal mining.](#) 9897
- [The Mechanical Reeling of Silk.—An advanced method of treating silk cocoons, designed to dispense with the old hand winding of the raw silk.—3 illustrations.](#) 9898

THE SPANISH TORPEDO BOAT AZOR.

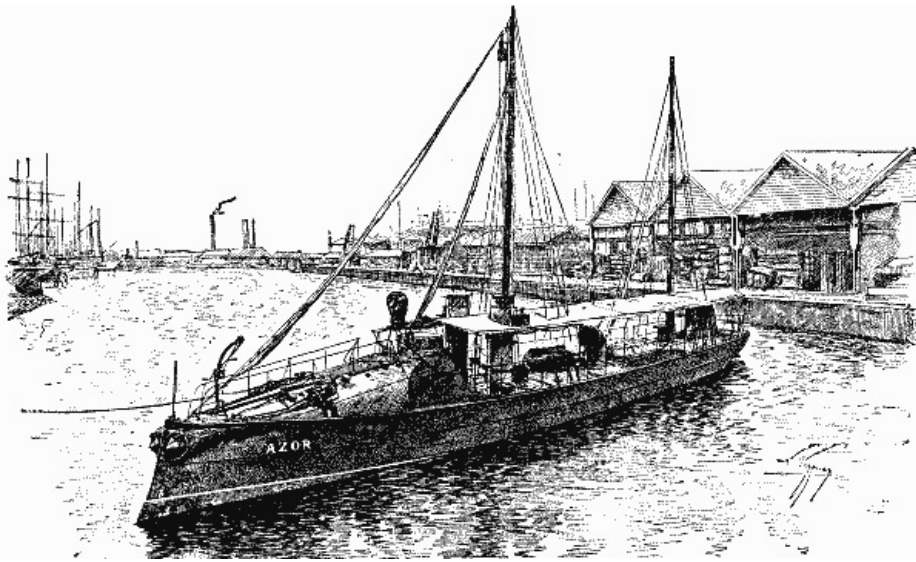

THE SPANISH TORPEDO BOAT AZOR.

The Azor was built by Yarrow & Co., London, is of the larger class, having a displacement of 120 tons, and is one of the fastest boats afloat. Her speed is 24½ miles per hour. She has two tubes for launching torpedoes and three rapid firing Nordenfolt guns. She lately arrived in Santander, Spain, after the very rapid passage of forty hours from England.

THE NEW SPANISH ARMORED CRUISER REINA REGENTE.

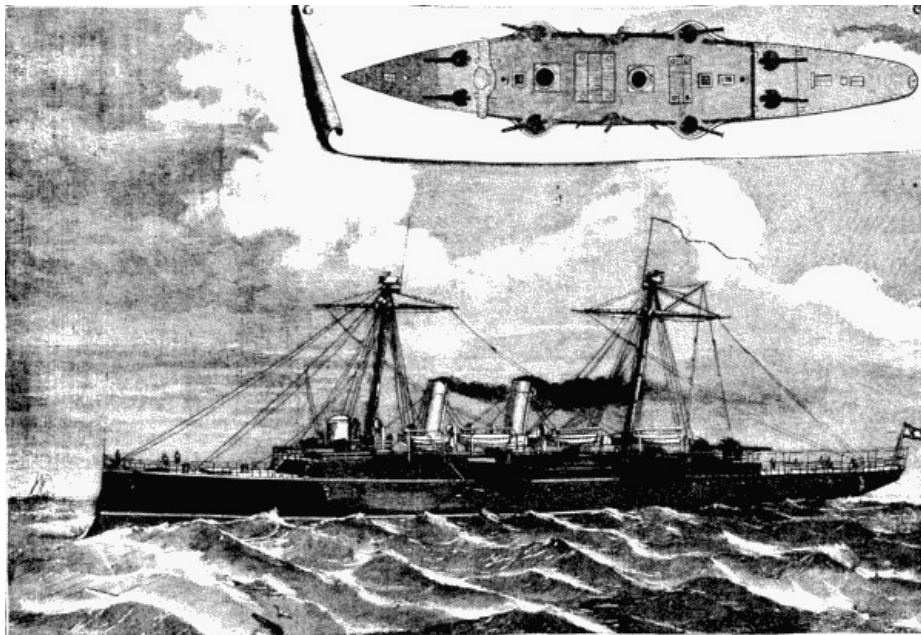

THE NEW SPANISH ARMORED CRUISER REINA REGENTE.

The new armored cruiser Reina Regente, which has been built and engined by Messrs. James & George Thomson, of Clydebank, for the Spanish government, has recently completed her official speed trials on the Clyde, the results attained being sufficient to justify the statement made on her behalf that she is the fastest war cruiser in the world. She is a vessel of considerable size, the following being her measurements: Length over all, 330 ft., and 307 ft. between perpendiculars; breadth, 50½ ft.; and her draught is 20 ft., giving a displacement of 5,000 tons, which will be increased to 5,600 tons when she is fully equipped.

This vessel belongs to the internally protected type of war cruisers, a type of recent origin, and of which she is the largest example yet built. The internal protection includes an armored deck which consists of steel plates ranging from 3-1/8 in. in thickness in the flat center to 4¾ in. at the sloping sides of the deck. This protective deck covers the "vitals" of the ship, the machinery, boilers, etc. Then there is a very minute subdivision in the hull of the ship, there being, in all, 156 water-tight compartments, 83 of which are between the armored deck and the one immediately above it, or between wind and water. Most of these compartments are used as coal bunkers. Of the remainder of the water-tight compartments, 60 are beneath the armor. Throughout her whole length the Reina Regente has a double bottom, which

also extends from side to side of the ship. In order to keep the vessel as free of water as possible, there have been fitted on board four 14 in. centrifugal pumps, all of which are connected to a main pipe running right fore and aft in the ship, and into which branches are received from every compartment. These pumps are of the "Bon Accord" type, and were supplied by Messrs. Drysdale & Co., Glasgow.

Not being weighted by massive external armor, the *Reina Regente* is unusually light in proportion to her bulk, and in consequence it has been rendered possible to supply her with engines of extraordinary power. They are of the horizontal triple expansion type, driving twin screws, and placed in separate water-tight compartments. The boilers, four in number, are also in separate compartments. Well above the water line there are two auxiliary boilers, which were supplied by Messrs. Merryweather, London, and are intended for raising steam rapidly in cases of emergency. These boilers are connected with all the auxiliary engines of the ship, numbering no fewer than forty-three.

The engines have been designed to indicate 12,000 horse power, and on the trial, when they were making 110 revolutions per minute, they indicated considerably upward of 11,000 horse power, the bearings all the while keeping wonderfully cool, and the temperature of the engine and boiler rooms being never excessive. The boilers are fitted with a forced draught arrangement giving a pressure of 1 in. of water. In the official run she attained a speed equal to 21 knots (over 24 miles) per hour, and over a period of four hours an average speed of 20.72 knots per hour was developed, without the full power of the engines being attained. The average steam pressure in the boilers was 140 lb. per square inch. In the course of some private trials made by the builders, the consumption of coal was tested, with the result that while the vessel was going at a moderate speed the very low consumption of 14 lb. of coal per indicated horse power per hour was reached. The vessel is capable of steaming 6,000 knots when there is a normal supply of coal in her bunkers, and when they are full there is sufficient to enable her to steam 13,000 knots.

The *Reina Regente* will be manned by 50 officers and a crew of 350 men, all of whom will have their quarters on the main deck. Among her fittings and equipment there are three steam lifeboats and eight other boats, five of Sir William Thomson's patent compasses, and a complete electric light installation, the latter including two powerful search lights, which are placed on the bridge. All parts of the vessel are in communication by means of speaking tubes. In order to enable the vessel to turn speedily, she is fitted with the sternway rudder of Messrs. Thomson & Biles. This contrivance is a combination of a partially balanced rudder with a rudder formed as a continuation of the after lines of a ship. The partial balance tends to reduce the strains on the steering gear, and thereby enables the rudder area to be increased without unduly straining the gear.

When fitted out for actual service, this novel war cruiser will have a most formidable armament, consisting of four 24 centimeter Hontorio guns (each of 21 tons), six 12 centimeter guns (also of the Hontorio type), six 6 pounder Nordenfelt guns, fourteen small guns, and five torpedo tubes—one at the stern, two amidships, and two at the bow of the ship.

It is worthy of note that this war cruiser was constructed in fifteen months, or three months under the stipulated contract time; in fact, the official trial of the vessel took place exactly eighteen months from the signing of the contract. Not only is this the fastest war cruiser afloat, but her owners also possess in the *El Destructor* what is probably the simplest torpedo catcher afloat, a vessel which has attained a speed of 22½ knots, or over 26 miles, per hour.—*Engineering*.

OLIVER EVANS AND THE STEAM ENGINE.

A correspondent of the *New York Times*, deeming that far too much credit has been given to foreigners for the practical development of the steam engine, contributes the following interesting *resume*:

Of all the inventions of ancient or modern times none have more importantly and beneficently influenced the affairs of mankind than the double acting high pressure steam engine, the locomotive, the steam railway system, and the steamboat, all of which inventions are of American origin. The first three are directly and the last indirectly associated with a patent that was granted by the State of Maryland, in 1787, being the very year of the framing of the Constitution of the United States. In view of the momentous nature of the services which these four inventions have rendered to the material and national interests of the people of the United States, it is to be hoped that neither they nor their origin will be forgotten in the coming celebration of the centennial of the framing of the Constitution.

The high pressure steam engine in its stationary form is almost ubiquitous in

America. In all great iron and steel works, in all factories, in all plants for lighting cities with electricity, in brief, wherever in the United States great power in compact form is wanted, there will be found the high pressure steam engine furnishing all the power that is required, and more, too, if more is demanded, because it appears to be equal to every human requisition. But go beyond America. Go to Great Britain, and the American steam engine—although it is not termed American in Great Britain—will be found fast superseding the English engine—in other words, James Watt's condensing engine. It is the same the world over. On all the earth there is not a steam locomotive that could turn a wheel but for the fact that, in common with every locomotive from the earliest introduction of that invention, it is simply the American steam engine put on wheels, and it was first put on wheels by its American inventor, Oliver Evans, being the same Oliver Evans to whom the State of Maryland granted the before mentioned patent of 1787.

He is the same Oliver Evans whom Elijah Galloway, the British writer on the steam engine, compared with James Watt as to the authorship of the locomotive, or rather "steam carriage," as the locomotive was in those days termed. After showing the unfitness of Mr. Watt's low pressure steam engine for locomotive purposes, Mr. Galloway, more than fifty years ago, wrote: "We have made these remarks in this place in order to set at rest the title of Mr. Watt to the invention of steam carriages. And, taking for our rule that the party who first attempted them in practice by mechanical arrangements of his own is entitled to the reputation of being their inventor, Mr. Oliver Evans, of America, appears to us to be the person to whom that honor is due." He is the same Oliver Evans whom the *Mechanics' Magazine*, of London, the leading journal of its kind at that period, had in mind when, in its number of September, 1830, it published the official report of the competitive trial between the steam carriages Rocket, San Paniel, Novelty, and others on the Liverpool and Manchester Railway.

In that trial the company's engines developed about 15 miles in an hour, and spurts of still higher speed. The *Magazine* points to the results of the trial, and then, under the heading of "The First Projector of Steam Traveling," it declares that all that had been accomplished had been anticipated and its feasibility practically exemplified over a quarter of a century before by Oliver Evans, an American citizen. The *Magazine* showed that many years before the trial Mr. Evans had offered to furnish steam carriages that, on level railways, should run at the rate of 300 miles in a day, or he would not ask pay therefor. The writer will state that this offer by Mr. Evans was made in November, 1812, at which date not a British steam carriage had yet accomplished seven miles in an hour.

In 1809 Mr. Evans endeavored to establish a steam railway both for freight and passenger traffic between New York and Philadelphia, offering to invest \$500 per mile in the enterprise. At the date of his effort there was not a railway in the world over ten miles long, nor does there appear to have been another human being who up to that date had entertained even the thought of a steam railway for passenger and freight traffic. In view of all this, is it at all surprising that the British *Mechanics' Magazine* declared Oliver Evans, an American, to be the first projector of steam railway traveling? In 1804 Mr. Evans made a most noteworthy demonstration, his object being to practically exemplify that locomotion could be imparted by his high pressure steam engine to both carriages and boats, and the reader will see that the date of the demonstration was three years before Fulton moved a boat by means of Watt's low pressure steam engine. The machine used involved the original double acting high pressure steam engine, the original steam locomotive, and the original high pressure steamboat. The whole mass weighed over twenty tons.

Notwithstanding there was no railway, except a temporary one laid over a slough in the path, Mr. Evans' engine moved this great weight with ease from the southeast corner of Ninth and Market streets, in the city of Philadelphia, one and a half miles, to the River Schuylkill. There the machine was launched into the river, and the land wheels being taken off and a paddle wheel attached to the stern and connected with the engine, the now steamboat sped away down the river until it emptied into the Delaware, whence it turned upward until it reached Philadelphia. Although this strange craft was square both at bow and stern, it nevertheless passed all the up-bound ships and other sailing vessels in the river, the wind being to them ahead. The writer repeats that this thorough demonstration by Oliver Evans of the possibility of navigation by steam was made three years before Fulton. But for more than a quarter of a century prior to this demonstration Mr. Evans had time and again asserted that vessels could be thus navigated. He did not contend with John Fitch, but on the contrary tried to aid him and advised him to use other means than oars to propel his boat. But Fitch was wedded to his own methods. In 1805 Mr. Evans published a book on the steam engine, mainly devoted to his form thereof. In this book he gives directions how to propel boats by means of his engine against the current of the Mississippi. Prior to this publication he associated himself with some citizens of Kentucky—one of whom was the grandfather of the present Gen. Chauncey McKeever, United States Army—the purpose being to build a steamboat to

run on the Mississippi. The boat was actually built in Kentucky and floated to New Orleans. The engine was actually built in Philadelphia by Mr. Evans and sent to New Orleans, but before the engine arrived out the boat was destroyed by fire or hurricane. The engine was then put to sawing timber, and it operated so successfully that Mr. Stackhouse, the engineer who went out with it, reported on his return from the South that for the 13 months prior to his leaving the engine had been constantly at work, not having lost a single day!

The reader can thus see the high stage of efficiency which Oliver Evans had imparted to his engine full 80 years ago. On this point Dr. Ernst Alban, the German writer on the steam engine, when speaking of the high pressure steam engine, writes: "Indeed, to such perfection did he [Evans] bring it, that Trevithick and Vivian, who came after him, followed but clumsily in his wake, and do not deserve the title of either inventors or improvers of the high pressure engine, which the English are so anxious to award to them.... When it is considered under what unfavorable circumstances Oliver Evans worked, his merit must be much enhanced; and all attempts made to lessen his fame only show that he is neither understood nor equaled by his detractors."

The writer has already shown that there are bright exceptions to this general charge brought by Dr. Alban against British writers, but the overwhelming mass of them have acted more like envious children than like men when speaking of the authorship of the double acting high pressure steam engine, the locomotive, and the steam railway system. Speaking of this class of British writers, Prof. Renwick, when alluding to their treatment of Oliver Evans, writes: "Conflicting national pride comes in aid of individual jealousy, and the writers of one nation often claim for their own vain and inefficient projectors the honors due to the successful enterprise of a foreigner." Many of these writers totally ignore the very existence of Oliver Evans, and all of them attribute to Trevithick and Vivian the authorship of the high pressure steam engine and the locomotive. Yet, when doing so, all of them substantially acknowledge the American origin of both inventions, because it is morally certain that Trevithick and Vivian got possession of the plans and specifications of his engine. Oliver Evans sent them to England in 1794-5 by Mr. Joseph Stacy Sampson, of Boston, with the hope that some British engineer would approve and conjointly with him take out patents for the inventions. Mr. Sampson died in England, but not until after he had extensively exhibited Mr. Evans' plans, apparently, however, without success. After Mr. Sampson's death Trevithick and Vivian took out a patent for a high pressure steam engine. This could happen and yet the invention be original with them.

But they introduced into Cornwall a form of boiler hitherto unknown in Great Britain, namely, the cylindrical flue boiler, which Oliver Evans had invented and used in America years before the names of Trevithick and Vivian were associated with the steam engine. Hence, they were charged over fifty years ago with having stolen the invention of Mr. Evans, and the charge has never been refuted. Hence when British writers ignore the just claims of Oliver Evans and assert for Trevithick and Vivian the authorship of the high pressure steam engine and the locomotive, they thereby substantially acknowledge the American origin of both inventions. They are not only of American origin, but their author, although born in 1755, was nevertheless an American of the second generation, seeing that he was descended from the Rev. Dr. Evans Evans, who in the earlier days of the colony of Pennsylvania came out to take charge of the affairs of the Episcopal Church in Pennsylvania.

The writer has thus shown that with the patent granted by the State of Maryland to Oliver Evans in 1787 were associated—first, the double acting high pressure steam engine, which to-day is the standard steam engine of the world; second, the locomotive, that is in worldwide use; third, the steam railway system, which pervades the world; fourth, the high pressure steamboat, which term embraces all the great ocean steamships that are actuated by the compound steam engine, as well as all the steamships on the Mississippi and its branches.

The time and opportunity has now arrived to assert before all the world the American origin of these universally beneficent inventions. Such a demonstration should be made, if only for the instruction of the rising generation. Not a school book has fallen into the hands of the writer that correctly sets forth the origin of the subject matter of this paper. He apprehends that it is the same with the books used in colleges and universities, for otherwise how could that parody on the history of the locomotive, called "The Life of George Stephenson, Railway Engineer," by Samuel Smiles, have met such unbounded success? To the amazement of the writer, a learned professor in one of the most important institutions of learning in the country did, in a lecture, quote Smiles as authority on a point bearing on the history of the locomotive! It is true that he made amends by adding, when his lecture was published, a counter statement; but that such a man should have seriously cited such a work shows the widespread mischief done among people not versed in engineering lore by the admirably written romance of Smiles, who as Edward C. Knight, in his Mechanical

Dictionary, truly declares, has "pettified the whole case." If, as Prof. Renwick intimates, "conflicting national pride" has led the major part of British writers to suppress the truth as to the origin of the high pressure steam engine, the locomotive, and the steam railway system, surely true national pride should induce the countrymen of Oliver Evans to assert it. In closing this paper the writer will say, for the information of the so-called "practical" men of the country, or, in other words, those men whose judgment of an invention is mainly guided by its money value, that Poor's Manual of Railroads in the United States for 1886 puts their capital stock and their debts at over \$8,162,000,000. The value of the steamships and steamboats actuated by the high pressure steam engine the writer has no means of ascertaining. Neither can he appraise the factories and other plants in the United States—to say nothing of the rest of the world—in which the high pressure steam engine forms the motive power.

AUGUSTE'S ENDLESS STONE SAW.

It does not seem as if the band or endless saw should render the same services in sawing stone as in working wood and metals, for the reason that quite a great stress is necessary to cause the advance of the stone (which is in most cases very heavy) against the blade. Mr. A. Auguste, however, has not stopped at such a consideration, or, better, he has got round the difficulty by holding the block stationary and making the blade act horizontally. Fig. 1 gives a general view of the apparatus; Fig. 2 gives a plan view; Fig. 3 is a transverse section; Fig. 4 is an end view; Figs. 5, 6, and 7 show details of the water and sand distributor; and Figs. 8, 9, and 10 show the pulleys arranged for obtaining several slabs at once.

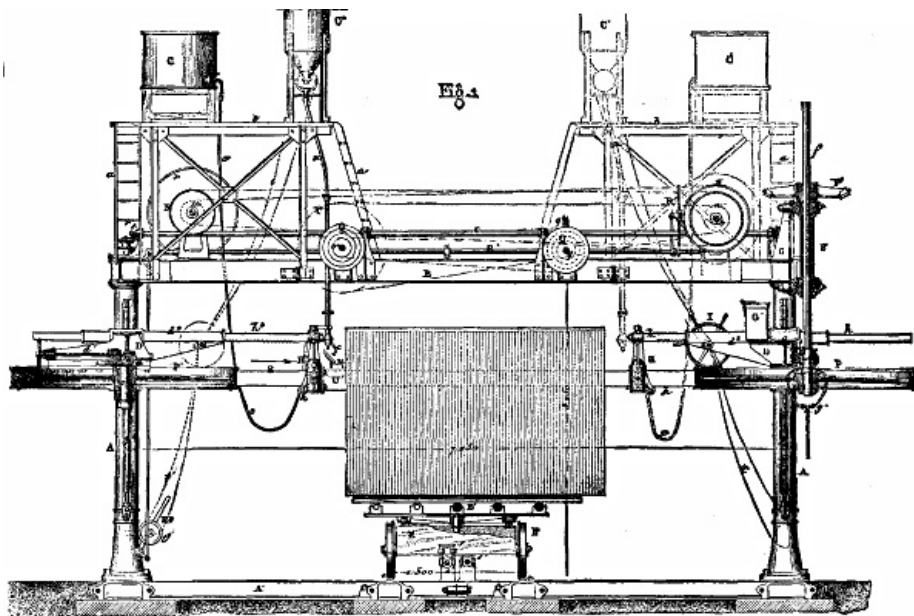

FIG. 1 AUGUSTE'S STONE SAW.

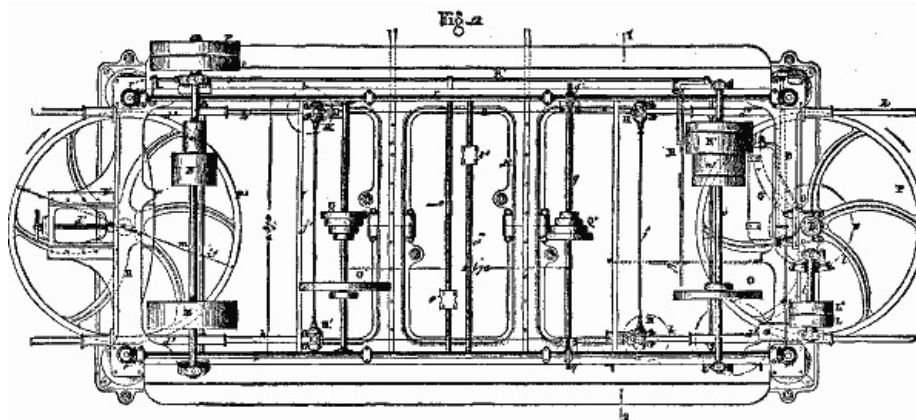
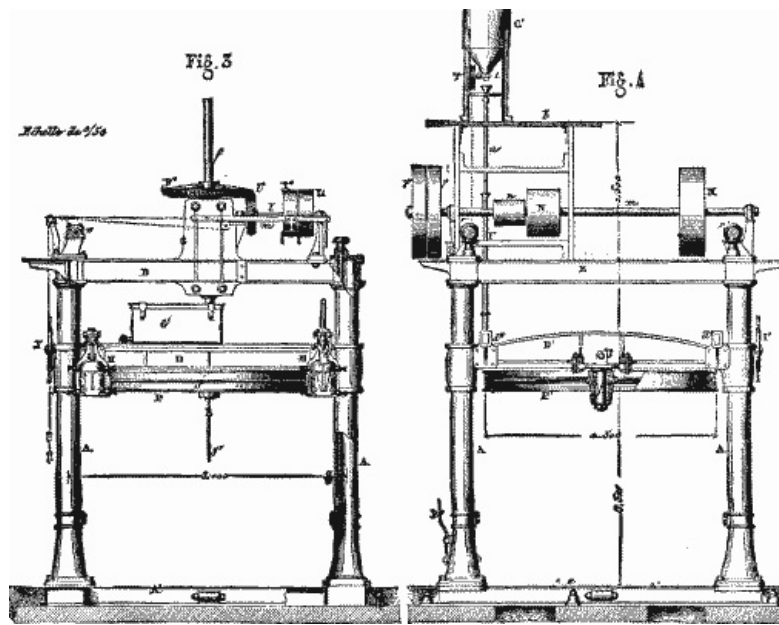
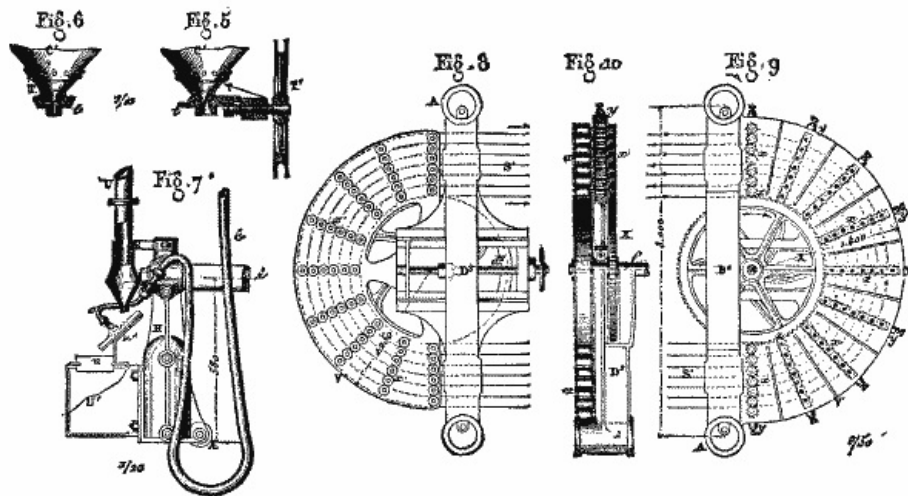

FIG. 2 AUGUSTE'S STONE SAW.



FIGS. 3 and 4 AUGUSTE'S STONE SAW.



FIGS. 5 through 10 AUGUSTE'S STONE SAW.

The machine is wholly of cast iron. The frame consists of four columns, A, bolted to a rectangular bed plate, A', and connected above by a frame, B, that forms a table for the support of the transmission pieces, as well as the iron ladders, a, and the platform, b, that supports the water reservoirs, C, and sand receptacles, C'.

Between the two columns at the ends of the machine there are two crosspieces, D and D', so arranged that they can move vertically, like carriages. These pieces carry the axles of the pulleys, P and P', around which the band saw, S, passes. In the center of the bed plate, A', which is cast in two pieces connected by bolts, there are ties to which are screwed iron rails, e, which form a railway over which the platform car, E, carrying the stone is made to advance beneath the saw.

The saw consists of an endless band of steel, either smooth or provided with teeth that are spaced according to the nature of the material to be worked. It passes around the pulleys, P and P', which are each encircled by a wide and stout band of rubber to cause the blade to adhere, and which are likewise provided with two flanges. Of the latter, the upper one is cast in a piece with the pulley, and the lower one is formed of sections of a circle connected by screws. The pulley, P, is fast, and carries along the saw; the other, P', is loose, and its hub is provided with a bronze socket (Figs. 1 and 4). It is through this second pulley that the blade is given the desired tension, and to this effect its axle is forged with a small disk adjusted in a frame and traversed by a screw, d', which is maneuvered through a hand wheel. The extremities of the crosspieces, D and D', are provided with brass sockets through which the pieces slide up and down the columns, with slight friction, under the action of the vertical screws, g and g', within the columns.

A rotary motion is communicated to the four screws simultaneously by the transmission arranged upon the frame. To this effect, the pulley, P, which receives the motion and transmits it to the saw, has its axle, f, prolonged, and grooved throughout its length in order that it may always be carried along, whatever be the place it occupies, by the hollow shaft, F, which is provided at the upper extremity with a bevel wheel and two keys placed at the level of the bronze collars of its

support, G. The slider, D, is cast in a piece with the pillow block that supports the shaft, f , and the bronze bushing of this pillow block is arranged to receive a shoulder and an annular projection, both forged with the shaft and designed to carry it, as well as the pulley, P, keyed to its extremity. Now the latter, by its weight, exerts a pressure which determines a sensible friction upon the bushing through this shoulder and projection, and, in order to diminish the same, the bushing is continuously moistened with a solution of soap and water through the pipe, g , which runs from the reservoir, G'.

The saw is kept from deviating from its course by movable guides placed on the sliders, D and D'. These guides, H and H', each consist of a cast iron box fixed by a nut to the extremity of the arms, h and h' , and coupled by crosspieces, j and j' , which keep them apart and give the guides the necessary rigidity.

The shaft, m , mounted in pillow blocks fixed to the left extremity of the frame, receives motion from the motor through the pulley, p , at the side of which is mounted the loose pulley, p . This motion is transmitted by the drum, M, and the pulley, L, to the shaft, l , at the other extremity. This latter is provided with a pinion, l' , which, through the wheel, F', gives motion to the saw. The shaft, m , likewise controls the upward or downward motion of the saw through the small drums, N and n , and the two pairs of fast and loose pulleys, N' and n' . This shaft, too, transmits motion (a very slow one) to the four screws, g and g' , in the interior of the columns, and the nuts of which are affixed to the sliders, D and D'. To this effect, the shaft, q , is provided at its extremities with endless screws that gear with two wheels, q' , with helicoidal teeth fixed near the middle of two parallel axes, r , running above the table, B, and terminating in bevel wheels, r' , that engage with similar wheels fixed at the end of the screws, g and g' .

The car that carries the block to the saw consists of a strong frame, E, mounted upon four wheels. This frame is provided with a pivot and a circular track for the reception of the cast iron platform, E', which rests thereon through the intermedium of rollers. Between the rails, e , and parallel with them, are fixed two strong screws, e' , held by supports that raise them to the bottom of the car frame, so that they can be affixed thereto. When once the car is fastened in this way, the screws are revolved by means of winches, and the block is thus made to advance or recede a sufficient distance to make the lines marked on its surface come exactly opposite the saw blade.

In sawing hard stones, it is necessary, as well known, to keep up a flow of water and fine sand upon the blade in order to increase its friction. Upon two platforms, b , at the extremities of the machine, are fixed the water reservoir, C, and the receptacles, C', containing fine sand or dry pulverized grit stone. As may be seen from Figs. 5 and 6, the bottom of the sand box, C', is conical and terminates in a hopper, T, beneath which is adjusted a slide valve, t , connected with a screw that carries a pulley, T'. By means of this valve, the bottom of the hopper may be opened or closed in such a way as to regulate the flow of the sand at will by acting upon the pulley, T', through a chain, t' , passing over the guide pulley, t^2 . A rubber tube, u , which starts from the hopper, runs into a metal pipe, U, that descends to the guide, H, with which it is connected by a collar. Under the latter, this pipe terminates in a sphere containing a small aperture to allow the sand to escape upon an inclined board provided with a flange. At the same time, through the rubber tube, c , coming from the reservoir, C, a stream of water is directed upon the board in order to wet the sand.

As the apparatus with but a single endless saw makes but two kerfs at once, Mr. Auguste has devised an arrangement by means of which several blades may be used, and the work thus be expedited.

Without changing the general arrangements, he replaces the pulleys, P and P', by two half drums, V and V' (Figs. 8, 9, and 10), which are each cast in a piece with the crosspieces, D² and D³, designed to replace D and D', and, like them, sliding up and down the columns, A, of the frame. Motion is transmitted to all the saw blades by a cog wheel, X, keyed to the vertical shaft, f , and gearing with small pinions, x , which are equally distant all around, and which themselves gear with similar pinions forming the radii of a succession of circles concentric with the first. All these pinions are mounted upon axles traversing bronze bearings within the drum, which, to this effect, is provided with slots. The axles of the pinions are prolonged in order to receive rollers, x' , surrounded with rubber so as to facilitate, through friction, the motion of all the blades running between them.

The other drum, V', is arranged in the same way, except that it is not cast in a piece with the carriage, D³, but is so adjusted to it that a tension may be exerted upon the blades by means of the screw, d , and its hand wheel.

Through this combination, all the blades are carried along at once in opposite directions and at the same speed.—*Publication Industrielle.*

ROBURITE, THE NEW EXPLOSIVE.

A series of experiments of great interest and vital importance to colliery owners and all those engaged in mining coal has been carried out during the last ten days in the South Yorkshire coal field. The new mines regulation act provides that any explosible used in coal mines shall either be fired in a water cartridge or be of such a nature that it cannot inflame firedamp. This indeed is the problem which has puzzled many able chemists during the last few years, and which Dr. Roth, of Berlin, claims to have solved with his explosive "roburite." We recently gave a detailed account of trials carried out at the School of Military Engineering, Chatham, to test the safety and strength of roburite, as compared with gun cotton, dynamite, and blasting gelatine. The results were conclusive of the great power of the new explosive, and so far fully confirmed the reports of the able mining engineer and the chemical experts who had been sent to Germany to make full inquiries. These gentlemen had ample opportunity of seeing roburite used in the coal mines of Westphalia, and it was mainly upon their testimony that the patents for the British empire were acquired by the Roburite Explosive Company.

It has, however, been deemed advisable to give practical proof to those who would have to use it, that roburite possesses all the high qualities claimed for it, and hence separate and independent trials have been arranged in such representative collieries as the Wharnccliffe Silkstone, near Sheffield, Monk Bretton, near Barnsley, and, further north, in the Durham coal field, at Lord Londonderry's Seaham and Silksworth collieries. Mr. G.B. Walker, resident manager of the Wharnccliffe Colliery Company, had gone to Germany as an independent observer—provided with a letter of introduction from the Under Secretary of State for Foreign Affairs—and had seen the director of the government mines at Saarbruck, who gave it as his opinion that, so far as his experience had gone, the new explosive was a most valuable invention. Mr. Walker was so impressed with the great advantages of roburite that he desired to introduce it into his own colliery, where he gladly arranged with the company to make the first coal mining experiments in this country. These were recently carried out in the Parkgate seam of the Wharnccliffe Silkstone colliery, under the personal superintendence of the inventor, Dr. Roth, and in the presence of a number of colliery managers and other practical men.

In all six shots were fired, five of which were for the purpose of winning coal, while the sixth was expressly arranged as a "blowout shot." The roburite—which resembles nothing so much as a common yellow sugar—is packed in cartridges of about 4½ in. in length and 1½ in. in diameter, each containing about 65 grammes (one-seventh of a pound) inclosed in a waterproof envelope. By dividing a cartridge, any desired strength of charge can be obtained. The first shot had a charge of 90 grammes (one-fifth of a pound) placed in a hole drilled to a depth of about 4 ft. 6 in., and 1¾ in. in diameter. All the safety lamps were carefully covered, so that complete darkness was produced, but there was no visible sign of an explosion in the shape of flame—not even a spark—only the dull, heavy report and the noise made by the displaced coal. A large quantity of coal was brought down, but it was considered by most of the practical men present to be rather too much broken. The second shot was fired with a single cartridge of 65 grammes, and this gave the same remarkable results as regards absence of flame, and, in each case, there were no noxious fumes perceivable, even the moment after the shot was fired. This reduced charge gave excellent results as regards coal winning, and one of the subsequent shots, with the same weight of roburite, produced from 10 to 11 tons of coal in almost a solid mass.

It has been found that a fertile cause of accidents in coal mines is insufficient tamping, or "stemming," as it is called in Yorkshire. Therefore a hole was bored into a strong wall of coal, and a charge of 45 grammes inserted, and very slightly tamped, with the view of producing a flame if such were possible. This "blowout" shot is so termed from the fact of its being easier for the explosion to blow out the tamping, like the shot from a gun, than to split or displace the coal. The result was most successful, as there was no flash to relieve the utter darkness.

The second set of experiments took place on October 24 last, in the Monk Bretton colliery, near Barnsley, of which Mr. W. Pepper, of Leeds, is owner. This gentleman determined to give the new explosive a fair and exhaustive trial, and the following programme was carried out in the presence of a very large gathering of gentlemen interested in coal mining. The chief inspector of mines for Yorkshire and Lincolnshire, Mr. F.N. Wardell, was also present, and the Roburite Explosives Company was represented by Lieut.-General Sir John Stokes, K.C.B., R.E., chairman, and several of the directors.

1. *Surface Experiments.*—A shot fired on the ground, exposed. This gave no perceptible flame (70 grammes of roburite was the charge in these experiments).
2. A shot fired on the ground, bedded in fine coal dust. No flame nor ignition of the coal dust was perceptible.

3. A shot fired suspended in a case into which gas was conducted, and the atmospheric air allowed to enter so as to form an explosive mixture. The gas was not fired.

4. A shot fired in a boiler flue 16 ft. by 2 ft. 8 in., placed horizontally, in which was a quantity of fine coal dust kept suspended in the air by the action of a fan. No flame nor ignition of the coal dust took place.

5. A shot fired as above, except that an explosive mixture of gas and air was flowing into the boiler tube in addition to the coal dust. That this mixture was firedamp was proved by the introduction of a safety lamp, the flame of which was elongated, showing what miners call the "blue cap." There was no explosion of the gas or sign of flames.

6. A shot of roburite fired in the boiler tube without any gas or suspended coal dust. The report was quite as loud as in the preceding case; indeed, to several present it seemed more distinct.

7. A shot of $\frac{1}{2}$ lb. gunpowder was fired under the same condition as No. 5, *i.e.*, in an explosive mixture of gas and air with coal dust. The result was most striking, and appeared to carry conviction of the great comparative safety of roburite to all present. Not only was there an unmistakable explosion of the firedamp, with very loud report, and a vivid sheet of flame, but the gas flowing into the far end of the boiler tube was ignited and remained burning until turned off.

In the Pit.—1. A 2 in. hole was drilled 4 ft. 6 in. deep into coal, having a face 7 yards wide, fast at both ends, and holed under for a depth of 8 ft., end on, thickness of front of coal to be blown down 2 ft. 10 in., plus 9 in. of dirt. This represented a most difficult shot, having regard to the natural lines of cleavage of the coal—a "heavy job" as it was locally termed. The charge was 65 grammes of roburite, which brought down a large quantity of coal, not at all too small in size. No flame was perceptible, although all the lamps were carefully covered.

2. A 2 in. hole drilled 4 ft. 6 in. into the side of the coal about 10 in. from the top, fast ends not holed under, width of space 10 ft. This was purposely a "blowout" shot. The result was again most satisfactory, the charge exploding in perfect darkness.

3. A "breaking up" shot placed in the stone roof for "ripping," the hole being drilled at an angle of 35 deg. or 40 deg. This is intended to open a cavity in the perfectly smooth roof, the ripping being continued by means of the "lip" thus formed. The charge was 105 grammes (nearly 4 oz), and it brought down large quantities of stone.

4. A "ripping" shot in the stone roof, hole 4 ft. 6 in. deep, width of place 15 ft. with a "lip" of 2 ft. 6 in. This is a strong stone "bind," and very difficult to get down. The trial was most successful, a large heap of stone being brought down and more loosened.

5. A second "blowout" shot, under the conditions most likely to produce an accident in a fiery mine. A 2 in. hole, 4 ft. 6 in. deep, was drilled in the face of the coal near the roof, and charged with 105 grammes of roburite. A space of 6 in. or 8 in. was purposely left between the charge and the tamping. The hole was then strongly tamped for a distance of nearly 2 ft. The report was very loud, and a trumpet-shaped orifice was formed at the mouth of the hole, but no flame or spark could be perceived, nor was any inconvenience caused by the fumes, even the instant after the explosion.

Further Experiments at Wharnccliffe Colliery.—On Tuesday, October 25, some very interesting surface trials were arranged with great care by Mr. Walker. An old boiler flue was placed vertically, and closed at top by means of a removable wooden cover, the interior space being about 72 cubic feet. A temporary gasometer had been arranged at a suitable distance by means of a paraffin cask having a capacity of 6 cubic feet suspended inside a larger cask, and by this means the boiler was charged with a highly explosive mixture of gas and air in the proportion of 1 to 12.

1. A charge of gunpowder was placed in the closed end of a piece of gas pipe, and strongly tamped, so as to give the conditions most unfavorable to the ignition of the firedamp. It was, however, ignited, and a loud explosion produced, which blew off the wooden cover and filled the boiler tube with flame.

2. Under the same conditions as to firedamp, a charge of roburite was placed on a block of wood inside the boiler, totally unconfined except by a thin covering of coal dust. When exploded by electricity, as in the previous case, no flame was produced, nor was the firedamp ignited.

3. The preceding experiment was repeated with the same results.

4. A charge of blasting gelatine, inserted in one of Settle's water cartridges, was suspended in the boiler tube and fired with a fulminate of mercury detonator in the usual manner. The gelatine did not, however, explode, the only report being that of the detonator. After a safe interval the unexploded cartridge was recovered, or so much of it as had not been scattered by the detonator, and the gelatine was found to be frozen. This fact was also evident from an inspection of other gelatine dynamite cartridges which had been stored in the same magazine during the night. This result, although not that intended, was most instructive as regards the danger of using explosives which are liable to freeze at such a moderate temperature, and the thawing of which is undoubtedly attended with great risk unless most carefully performed. Also, the small pieces of the gelatine or dynamite, when scattered by the explosion of the detonator, might cause serious accident if trodden upon.
—*Engineering.*

THE MECHANICAL REELING OF SILK.

When automatic machinery for thread spinning was invented, English intelligence and enterprise were quick to utilize and develop it, and thus gained that supremacy in textile manufacture which has remained up to the present time, and which will doubtless long continue. The making of the primary thread is the foundation of all textile processes, and it is on the possibility of doing this by automatic machinery that England's great textile industries depend. The use of highly developed machinery for spinning cotton, wool, and flax has grown to be so much a part of our conception of modern life, as contrasted with the times of our grandfathers, as often to lead to the feeling that a complete and universal change has occurred in all the textile industries. This is, however, not the case. There is one great textile industry—one of the most staple and valuable—still in the primitive condition of former times, and employing processes and apparatus essentially the same as those known and employed before such development had taken place. We mean the art of silk reeling. The improvements made in the production of threads of all other materials have only been applied to silk in the minor processes for utilizing waste; but the whole silk trade and manufacture of the world has, up to this time, been dependent for its raw silk threads upon apparatus which, mechanically speaking, is nearly or quite as primitive as the ancient spinning wheels. Thousands of operatives are constantly employed in forming up these threads by hand, adding filament by filament to the thread as required, while watching the unwinding from the cocoon of many miles of filament in order to produce a single pound of the raw silk thread, making up the thread unaided by any mechanical device beyond a simple reel on which the thread is wound as finished, and a basin of heated water in which the cocoons are placed.

Viewed from any standpoint to which we are accustomed, this state of things is so remarkable that we are naturally led to the belief that there must be some special causes which tended to retard the introduction of automatic machinery, and these are not far to seek. The spinning machinery employed for the production of threads, other than those of raw silk, may be broadly described as consisting of devices capable of taking a mass of confused and comparatively short fibers, laying them parallel with one another, and twisting them into a cylindrical thread, depending for its strength upon the friction and interlocking of these constituent fibers.

This process is radically different from that employed to make a thread of raw silk, which consists of filaments, each several thousand feet long, laid side by side, almost without twist, and glued together into a solid thread by means of the "gum" or glue with which each filament is naturally coated. If this radical difference be borne in mind, but very little mechanical knowledge is required to make it evident that the principle of spinning machinery in general is utterly unsuited to the making up of the threads of raw silk. Since spinning machinery, as usually constructed for other fibers, could not be employed in the manufacture of raw silk, and as the countries where silk is produced are, generally speaking, not the seat of great mechanical industries, where the need of special machinery would be quickly recognized and supplied, silk reeling (the making of raw silk) has been passed by, and has never become an industrial art. It remained one of the few manual handicrafts, while yet serving as the base of a great and staple industry of worldwide importance.

There is every reason to suppose that we are about to witness a transformation in the art of silk reeling, a change similar to that which has already been brought about in the spinning of other threads, and of which the consequences will be of the highest importance. For some years past work has been done in France in developing an automatic silk-reeling machine, and incomplete notes concerning it have from time to time been published. That the accounts which were allowed to reach the outer world were incomplete will cause no surprise to those who know what experimental work is—how easily and often an inventor or pioneer finds himself hampered by premature publication. The process in question has now, however, emerged from the experimental state, and is practically complete. By the courtesy of the inventor we

are in a position to lay before our readers an exact analysis of the principles, essential parts, and method of operation of the new silk-reeling machine. As silk reeling is not widely known in England, it will, however, be well to preface our remarks by some details concerning the cocoon and the manner in which it is at present manufactured into raw silk, promising that if these seem tedious, the labor of reading them will be amply repaid by the clearer understanding of the new mechanical process which will be the result.

The silkworm, when ready to make its cocoon, seeks a suitable support. This is usually found among the twigs of brush placed for the purpose over the trays in which the worms have been grown. At first the worm proceeds by stretching filaments backward and forward from one twig to another in such manner as to include a space large enough for the future cocoon. When sufficient support has thus been obtained, the worm incloses itself in a layer of filaments adhering to the support and following the shape of the new cocoon, of which it forms the outermost stratum. After having thus provided a support and outlined the cocoon, the worm begins the serious work of construction. The filament from its silk receiver issues from two small spinnarets situated near its jaws. Each filament, as it comes out, is coated with a layer of exceedingly tenacious natural gum, and they at once unite to form a single flattened thread, the two parts lying side by side. It is this flat thread, called the "baye" or "brin," which serves as the material for making the cocoon, and which, when subsequently unwound, is the filament used in making up the raw silk. While spinning, the worm moves its head continually from right to left, laying on the filament in a succession of lines somewhat resembling the shape of the figure eight. As the worm continues the work of making its cocoon, the filament expressed from its body in the manner described is deposited in nearly even layers all over the interior of the wall of the cocoon, which gradually becomes thicker and harder. The filament issuing from the spinnarets is immediately attached to that already in place by means of the gum which has been mentioned. When the store of silk in the body of the worm is exhausted, the cocoon is finished, and the worm, once more shedding its skin, becomes dormant and begins to undergo its change into a moth. It is at this point that its labors in the production of silk terminate and those of man begin. A certain number of the cocoons are set aside for reproduction.

In southern countries the reproduction of silkworms is a vast industry to which great attention is given, and which receives important and regular aid from the government. It is, however, quite distinct from the manufacturing industry with which at present we have to do. The cocoons to be used for reeling, *i.e.*, all but those which are reserved for reproduction, are in the first place "stifled," that is to say, they are put into a steam or other oven and the insect is killed. The cocoons are then ready for reeling, but those not to be used at once are allowed to dry. In this process, which is carried on for about two months, they lose about two-thirds of their weight, representing the water in the fresh chrysalis. The standard and dried cocoons form the raw material of the reeling mills, or filatures, as they are called on the Continent. Each filature endeavors as far as possible to collect, stifle, and dry the cocoons in its own neighborhood; but dried cocoons, nevertheless, give rise to an important commerce, having its center at Marseilles. The appearance of the cocoon is probably well known to most of our readers. Industrially considered, the cocoon may be divided into three parts: (1) The floss, which consists of the remains of the filaments used for supporting the cocoon on the twigs of the brush among which it was built and the outside layer of the cocoon, together with such ends and parts of the thread forming the main part of the shell as have become broken in detaching and handling the cocoon; (2) the shell of the cocoon, which is formed, as has been described, of a long continuous filament, which it is the object of the reeler to unwind and to form up into threads of raw silk; and (3) the dried body of the chrysalis.

We shall first describe the usual practice of reeling, which is as follows: The cocoons are put into a basin of boiling water, on the surface of which they float. They are stirred about so as to be as uniformly acted upon as possible. The hot water softens the gum, and allows the floss to become partially detached. This process is called "cooking" the cocoons. When the cocoons are sufficiently cooked, they are subjected to a process called "beating," or brushing, the object of which is to remove the floss.

As heretofore carried on, this brushing is a most rudimentary and wasteful operation. It consists of passing a brush of heather or broom twigs over the floating cocoons in such manner that the ends of the brush come in contact with the softened cocoons, catch the floss, and drag it off. In practice it happens that the brush catches the sound filaments on the surface of the cocoon as well as the floss, and, as a consequence, the sound filament is broken, dragged off, and wasted. In treating some kinds of cocoons as much as a third of the silk is wasted in this manner, and even in the best reeling, as at present practiced, there is an excessive loss from this cause. At the present low price of cocoons this waste is not as important as it was some time ago, when cocoons were much dearer; but even at present it amounts to between fifteen and twenty millions of francs per annum in the silk districts of France and Italy alone. In France the cooking and brushing are usually done by the

same women who reel, and in the same basins. In Italy the brushing is usually done by girls, and often with the aid of mechanically rotated brushes, an apparatus which is of doubtful utility, as, in imitating the movement of hand brushing, the same waste is occasioned.

After the cocoons are brushed they are, in the ordinary process, cleaned by hand, which is another tedious and wasteful operation performed by the reeler, and concerning which we shall have more to say further on. Whatever may be the preparatory operations, they result in furnishing the reeler with a quantity of cocoons, each having its floss removed, and the end of the filament ready to be unwound. Each reeler is provided with a basin containing water, which may be heated either by a furnace or by steam, and a reel, upon which the silk is wound when put in motion by hand or by power. In civilized countries heating by steam and the use of motive power is nearly universal. The reeler is ordinarily seated before the reel and the basin. The reeler begins operations by assembling the cocoons in the basin, and attaching all the ends to a peg at its side. She then introduces the ends of the filaments from several cocoons into small dies of agate or porcelain, which are held over the basin by a support.

The ends so brought in contact stick together, owing to the adhesive substance they naturally contain, and form a thread. To wring out the water which is brought up with the ends, and further consolidate the thread, it is so arranged as to twist round either itself or another similar thread during its passage from the basin to the reel. This process is called "croisure," and is facilitated by guides or small pulleys. Having made the croisure, which consists of about two hundred turns, the operator attaches the end of a thread to the reel, previously passing it through a guide fixed in a bar, which moves backward and forward, so as to distribute the thread on the reel, forming a hank about three inches wide.

The reel is now put into movement, and winds the thread formed by the union of the filaments. It is at this moment that the real difficulties of the reeler begin. She has now to maintain the size and regularity of the thread as nearly as possible by adding new filaments at the proper moment. The operation of adding an end of a filament consists of throwing it in a peculiar manner on the other filaments already being reeled, so that it sticks to them, and is carried up with them. We may mention here that this process of silk reeling can be seen in operation at the Manchester exhibition.

It is only after a long apprenticeship that a reeler succeeds in throwing the end properly. The thread produced by the several filaments is itself so fine that its size cannot readily be judged by the eye, and the speed with which it is being wound renders this even more difficult. But, in order to have an idea of the size, the reeler watches the cocoons as they unwind, counts them, and, on the hypothesis that the filament of one cocoon is of the same diameter as that of another, gets an approximate idea of the size of the thread that she is reeling. But this hypothesis is not exact, and the filament being largest at the end which is first unwound, and tapering throughout its whole length, the result is that the reeler has not only to keep going a certain number of cocoons, but also to appreciate how much has been unwound from each.

If the cocoons are but slightly unwound, there must be fewer than if a certain quantity of silk has been unwound from them. Consequently their number must be constantly varying in accordance with their condition. These facts show that the difficulty of maintaining regularity in a thread is very great. Nevertheless, this regularity is one of the principal factors of the value of a thread of "grege," and this to such an extent that badly reeled silks are sold at from twenty to twenty-five francs a kilogramme less than those which are satisfactorily regular.

The difficulty of this hand labor can be still better understood if it be remembered that the reeler being obliged to watch at every moment the unwinding of each cocoon, in order to obtain one pound of well reeled silk, she must incessantly watch, and without a moment of distraction, the unwinding of about two thousand seven hundred miles of silk filaments. For nine pounds of silk, she reels a length of filament sufficient to girdle the earth. The manufacturer, therefore, cannot and must not depend only on the constant attention that each reeler should give to the work confided to her care. He is obliged to have overseers who constantly watch the reelers, so that the defects in the work of any single reeler, who otherwise might not give the attention required by her work, will not greatly diminish the value either of her own work or that of several other reelers whose silk is often combined to form a single lot. In addition to the ordinary hand labor, considerable expense is thus necessitated for the watching of the reelers.

Enough has now been said, we think, to give a good idea of silk reeling, as usually practiced, and to show how much it is behind other textile arts from a mechanical point of view. To any one at all familiar with industrial work, or possessing the least power of analysis or calculation, it is evident that a process carried on in so primitive

a manner is entirely unsuitable for use in any country in which the conditions of labor are such as to demand its most advantageous employment. In the United States, for instance, or in England, silk reeling, as a great national industry, would be out of the question unless more mechanical means for doing it could be devised. The English climate is not suitable for the raising of cocoons, and in consequence the matter has not attracted very much attention in this country. But America is very differently situated. Previous to 1876 it had been abundantly demonstrated that cocoons could be raised to great advantage in many parts of that country. The only question was whether they could be reeled. In fact, it was stated at the time that the question of reeling silk presented a striking analogy to the question of cotton before the invention of the "gin." It will be remembered that cotton raising was several times tried in the United States, and abandoned because the fiber could not be profitably prepared for the market. The impossibility of competing with India and other cheap labor countries in this work became at least a fact fully demonstrated, and any hope that cotton would ever be produced in America was confined to the breasts of a few enthusiasts.

As soon, however, as it was shown that the machine invented by Eli Whitney would make it possible to do this work mechanically, the conditions were changed; cotton raising became not only possible, but the staple industry of a great part of the country; the population was rapidly increased, the value of real estate multiplied, and within a comparatively short time the United States became the leading cotton country of the world. For many years much more cotton has been grown in America than in all the other countries of the world combined; and it is interesting to note that both the immense agricultural wealth of America and the supply required for the cotton industry of England flow directly from the invention of the cotton gin.

Attention was turned in 1876 to silk raising, and it was found that all the conditions for producing cocoons of good quality and at low cost were most favorable. It was, however, useless to raise cocoons unless they could be utilized; in a word, it was seen that the country needed silk-reeling machinery in 1876, as it had needed cotton-ginning machinery in 1790. Under these conditions, Mr. Edward W. Serrell, Jr., an engineer of New York, undertook the study of the matter, and soon became convinced that the production of such machinery was feasible. He devoted his time to this work, and by 1880 had pushed his investigations as far as was possible in a country where silk reeling was not commercially carried on. He then went to France, where he has since been incessantly engaged in the heart of the silk-reeling district in perfecting, reducing to practice, and applying his improvements and inventions. The success obtained was such that Mr. Serrell has been enabled to interest many of the principal silk producers of the Continent in his work, and a revolution in silk reeling is being gradually brought about, for, strangely enough, he found that the work which he had undertaken solely for America was of equal importance for all silk-producing countries.

We have described the processes by which cocoons are ordinarily cooked and brushed, these being the first processes of the filature. Instead of first softening the gum of the cocoons and then attacking the floss with the points of a brush, Mr. Serrell places the cocoons in a receptacle full of boiling water, in which by various means violent reciprocating or vortex currents are produced. The result is that by the action of the water itself and the rubbing of the cocoons one against the other the floss is removed, carrying with it the end of the continuous filament without unduly softening the cocoon or exposing any of the more delicate filament to the rough action of the brush, as has hitherto been the case. The advantages of this process will be readily understood. In brushing after the ordinary manner, the point of the brush is almost sure to come into contact with and to break some of the filament forming the body of the cocoon. When this occurs, and the cocoon is sent to be reeled, it naturally becomes detached when the unwinding reaches the point at which the break exists. It then has to be sent back, and the end of the filament detached by brushing over again, when several layers of filament are inevitably caught by the brush and wasted, and very probably some other part of the filament is cut. This accounts for the enormous waste which occurs in silk reeling, and to which we have referred. Its importance will be appreciated when it is remembered that every pound of fiber thus dragged off by the brush represents a net loss of about 19s. at the present low prices.

The mechanical details by which Mr. Serrell carries out this process vary somewhat according to the nature of the different cocoons to be treated. In one type of machine the water is caused to surge in and out of a metal vessel with perforated sides; in another a vertical brush is rapidly raised and lowered, agitating the water in a basin, without, however, actually touching the cocoons. After a certain number of strokes the brush is automatically raised, when the ends of the filaments are found to adhere to it, having been swept against it by the scouring action of the water. The cleaning of the cocoons is performed by means of a mechanism also entirely new. In the brushing machinery the floss is loosened and partially detached from the cocoon. The object of the cleaning machine is to thoroughly complete the operation. To this end

the cocoons are floated under a plate, and the floss passed up through a slot in the latter. A rapid to and fro horizontal movement is given to the plate, and those cocoons from which the floss has been entirely removed easily give off a few inches of their filament, and allow themselves to be pushed on one side, which is accomplished by the cocoons which still have some floss adhering to them; because these latter, not being free to pay off, are drawn up to the slot in the plate, and by its motion are rapidly washed backward and forward in the water. This washing soon causes all the cocoons to be freed from the last vestiges of floss without breaking the filament, and after about twenty seconds of movement they are all free and clean, ready for reeling.

We have now to explain the operation of the machine by which the thread is formed from the prepared cocoon. At the risk of some repetition, however, it seems necessary to call attention to the character of the work itself. In each prepared cocoon are about a thousand yards of filament ready to pay off, but this filament is nearly as fine as a cobweb and is tapering. The object is to form a thread by laying these filaments side by side in sufficient number to obtain the desired size. For the threads of raw silk used in commerce, the sizes vary, so that while some require but an average of three filaments, the coarsest sizes require twenty-five or thirty. It being necessary keep the thread at as near the same size as possible, the work required is, in effect, to add an additional cocoon filament to the thread which is being wound whenever this latter has tapered down to a given size, or whenever one of the filaments going to form it has become detached. Those familiar with cotton spinning will understand what is meant when it is said that the reeling is effectively a "doubling" operation, but performed with a variable number of ends, so as to compensate for the taper of the filaments. In reeling by hand, as has been said, the size of the silk is judged, as nearly as possible, by a complex mental operation, taking into account the number, size, and state of unwinding of the cocoons. It is impossible to do this mechanically, if for no other reason than this, that the cocoons must be left free to float and roll about in the water in order to give off their ends without breaking, and any mechanical device which touched them would defeat the object of the machine. The only way in which the thread can be mechanically regulated in silk reeling is by some kind of actual measurement performed after the thread has left the cocoons. The conditions are such that no direct measurement of size can be made, even with very delicate and expensive apparatus; but Mr. Serrell discovered that, owing to the great tenacity of the thread in proportion to its size, its almost absolute elastic uniformity, and from the fact that it could be stretched, two or three per cent. without injury, it was possible to measure its size indirectly, but as accurately as could be desired. As this fact is the starting point of an entirely new and important class of machinery, we may explain with considerable detail the method in which this measurement is performed. Bearing in mind that the thread is of uniform quality, it is evident that it will require more force to stretch a coarse thread by a given percentage of its length than it will to stretch one that is finer. Supposing the thread is uniform in quality but varying in size, the force required to stretch it varies directly with the size or sectional area of the thread itself. In the automatic reeling machine this stretch is obtained by causing the thread to take a turn round a pulley of a given winding speed, and then, after leaving this pulley, to take a turn around a second pulley having a somewhat greater winding speed.

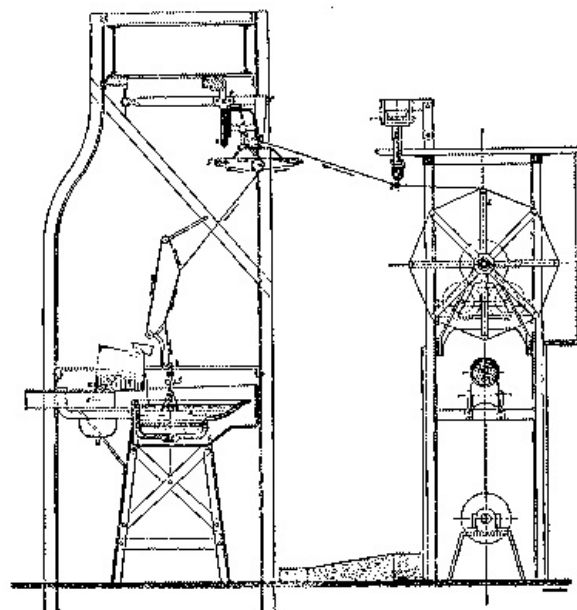

Fig. 1 THE MECHANICAL REELING OF SILK.

By this means the thread which is passing from one pulley to the other is stretched by an amount equal to the difference of the winding speed of the two pulleys. In the diagram (Fig. 2) the thread passes, as shown by the arrows, over the pulley, P, and

then over the pulley, P^1 , the latter having a slightly greater winding speed. Between these pulleys it passes over the guide pulley, G . This latter is supported by a lever hinged at S , and movable between the stops, TT^1 . W is an adjustable counterweight. When the thread is passed over the pulleys and guided in this manner, the stretch to which it is subjected tends to raise the guide and lever, so that the latter will be drawn up against the stop, T^1 , when the thread is so coarse that the effort required to stretch it is sufficient to overcome the weight of the guide pulley and the adjustable counterweight. But as the thread becomes finer, which, in the case of reeling silk, happens either from the tapering of the filaments or the dropping off of a cocoon, a moment arrives when it is no longer strong enough to keep up the lever and counterweight. These then descend, and the lever touches the lower stop, T . It will be readily seen that the up and down movements of the lever can be made to take place when the thread has reached any desired maximum or minimum of size, the limits being fixed by suitably adjusting the counterweight.

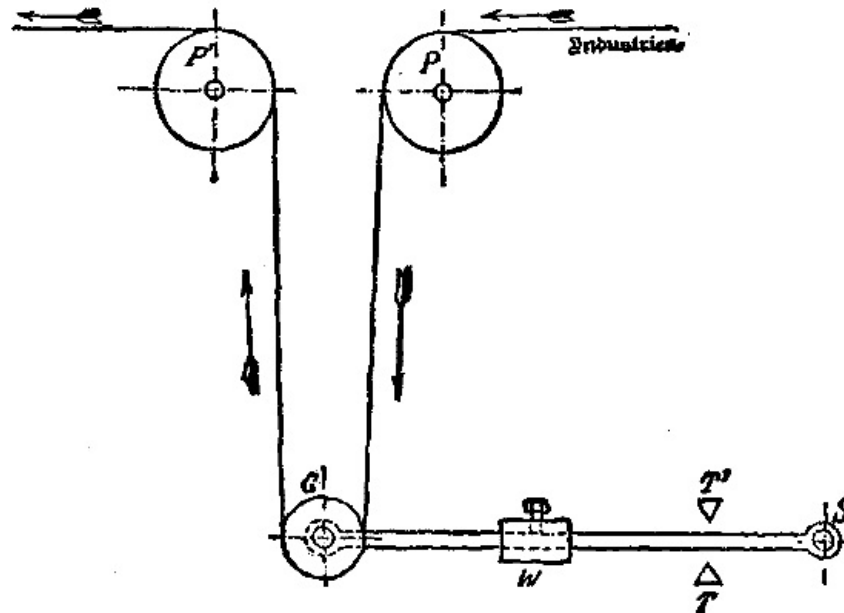

FIG. 2.

In the automatic reeling machine this is the method employed for regulating the supply of cocoons. The counterweight being suitably adjusted, the lever falls when the thread has become fine enough to need another cocoon. The stop, T , and the lever serve as two parts of an electric contact, so that when they touch each other a circuit is completed, which trips a trigger and sets in motion the feed apparatus by which a new cocoon is added. In practice the two drums or pulleys are mounted on the same shaft, D (Fig. 1), difference of winding speed being obtained by making them of slightly different diameters.

The lever is mounted as a horizontal pendulum, and the less or greater stress required according to the size to be reeled is obtained by inclining its axis to a less or greater degree from the vertical. An arrangement is also adopted by which the strains existing in the thread when it arrives at the first drum are neutralized, so far as their effect upon the lever is concerned. This is accomplished by simply placing upon the lever an extra guide pulley, L^1 , upon the side opposite to that which corresponds to the guide shown in the diagram, Fig. 2.

An electric contact is closed by a slight movement of the lever whenever the thread requires a new filament of cocoon, and broken again when the thread has been properly strengthened. It is evident that a delicate faller movement might be employed to set the feed mechanism in motion instead of the electric circuit, but, under the circumstances, as the motion is very slight and without force, being, in fact, comparable to the swinging of the beam of a balance through the space of about the sixteenth of an inch, it is simpler to use a contact.

The actual work of supplying the cocoons to the running thread is performed as follows: The cleaned cocoons are put into what is called the feeding basin, B^1 (Fig. 1), a receptacle placed alongside of the ordinary reeling basin, B , of a filature. A circular elevator, E , into which the cocoons are charged by a slight current of water, lifts them over one corner of the reeling basin and drops them one by one through an aperture in a plate about six inches above the water of the reeling basin.

The end of the filament having been attached to a peg above the elevator, it happens that when a cocoon has been brought into the corner of the reeling basin, the filament is strung from it to the edge of the hole in the plate in such a position as to be readily seized by a mechanical finger, K (Fig. 3), attached to a truck arranged to run backward and forward along one side of the basin. This finger is mounted on an

axis, and has a tang projecting at right angles to the side of the basin, so that the whole is in the form of a bell crank mounted on the truck.

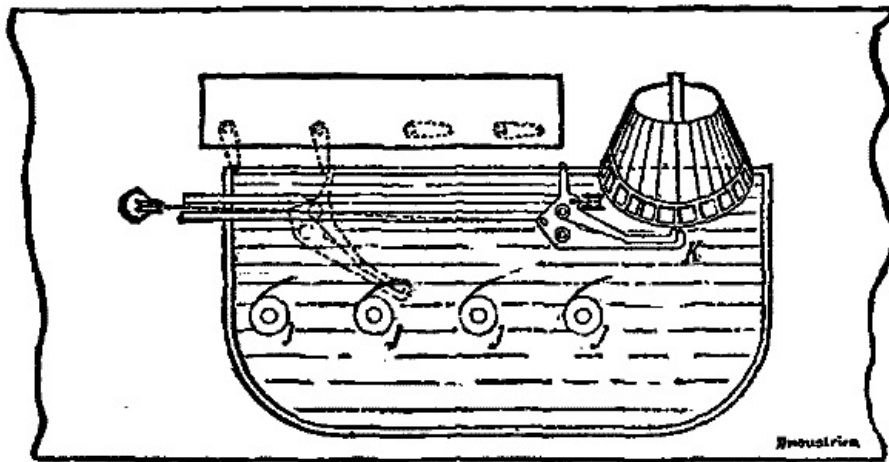

FIG. 3.

There are usually four threads to each basin. When neither one of them needs an additional cocoon, the finger of the distributing apparatus remains, holding the filament of the cocoon at the corner of the basin where it has been dropped. When a circuit is closed by the weakening of any one of the threads, an electromagnetic catch is released, and the truck with its finger is drawn across the basin by a weight. At the same time the stop shown dotted in Fig. 3 is thrown out opposite to the thread that needs strengthening. This stop strikes the tang of the finger, and causes the latter to be thrown out near to the point at which the filaments going to make up the weakened thread are being drawn from the cocoons. Here the new filament is attached to the new running thread by a kind of revolving finger, J, called in France a "lance-bout." This contrivance takes the place of the agate of the ordinary filature, and is made up, essentially, of the following parts:

- (1) A hollow axis, through the inside of which the thread passes instead of going through the hole of an agate. This hollow axis is furnished, near its lower end, with a ridge which serves to support a movable portion turning constantly round the axis.
- (2) A movable portion turning constantly round the axis.
- (3) A finger or hook fastened on the side of the movable portion and revolving with it. This hook, in revolving, catches the filament brought up by the finger and serves it on to the thread.

Such are the principal parts of the automatic reeling machine. Although the fact that this machine is entirely a new invention has necessitated a somewhat long explanation, its principal organs can nevertheless be summed up in a few words: (1) A controlling drum which serves to give the thread a constant elongation; (2) a pulley mounted on a pivot which closes an electric current every time that the thread becomes too fine, and attains, in consequence, its minimum strength, in other words, every time that a fresh cocoon is needed; (3) electromagnets with the necessary conducting wires; (4) the feeding basin; (5) distributing finger and stops; and (6) the lance-bout.

Our illustration, Fig. 1, shows diagrammatically a section through the cocoon frame and reel. The thread is composed of three, four, or more filaments, and after passing through the lance-bout, it travels as shown by the arrows. At first it is wound round itself about two hundred times, then passed over a fixed guide pulley, and over a second guide pulley lower down fixed to the frames which carry the lance-bouts, then up through the twist and over the smaller of the pulleys, D. Taking one complete turn, it is led round the guide pulley, L, from there round the larger of the pulleys, D, round the second guide pulley, L¹, then back to the large wheel, and over a fixed guide pulley across to the reeling frame. Power is supplied to the latter by means of a friction clutch, and to insure even winding the usual reciprocating motion of a guide is employed. The measuring apparatus is pivoted at F, and by raising or lowering the nuts at the end of the bar the required inclination is given.

We had recently an opportunity of examining the whole of this machinery in detail, and seeing the process of silk reeling in actual operation, Mr. Serrell having put up a complete set of his machines in Queen Victoria Street, London. Regarded simply as a piece of ingenious mechanism, the performance of these machines cannot fail to be of the highest interest to engineers, the reeling machine proper seeming almost endowed with human intelligence, so perfectly does it work. But, apart from the technical perfection, Mr. Serrell's improvements are of great importance as calculated to introduce the silk-reeling industry in this country on a large scale, while at the same time its effect upon India as a silk-growing country will be of equal importance.—*Industries*.

APPARATUS USED FOR MAKING ALCOHOL FOR HOSPITAL USE DURING THE CIVIL WAR BETWEEN THE STATES.¹

By CHARLES K. GALLAGHER, Washington, N.C.

A is an ordinary farm boiler or kettle, with an iron lid securely bolted on; B, a steam pipe ending in a coil within a trough, D. C, D, two troughs made of gum logs, one inverted over the other, securely luted and fastened together by clamps and wedges. The "beer" to be distilled was introduced at E and the opening closed with a plug. The distillate—"low wine"—was collected at F, and redistilled from a set of similar troughs not shown in above figure, and heated by a continuation of the steam coil from D.

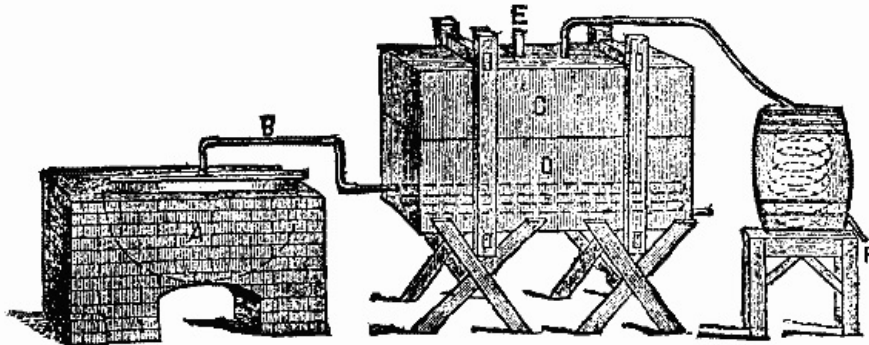

[1]

Read at the Cincinnati meeting of the American Pharmaceutical Association.

CONFEDERATE APPARATUS FOR MANUFACTURING SALTPETER FOR AMMUNITION.

By CHARLES K. GALLAGHER, Washington, N.C.

Any convenient number of percolators, made of rough boards, arranged over a trough after the style of the old fashioned "lye stand," similar to the figure. Into these was placed the earth scraped from around old tobacco barns, from under kitchens and smokehouses. Then water or water and urine was poured upon it until the mass was thoroughly leached or exhausted. The percolate was collected in a receptacle and evaporated, the salt redissolved, filtered, again evaporated, and crystallized from the mother water.

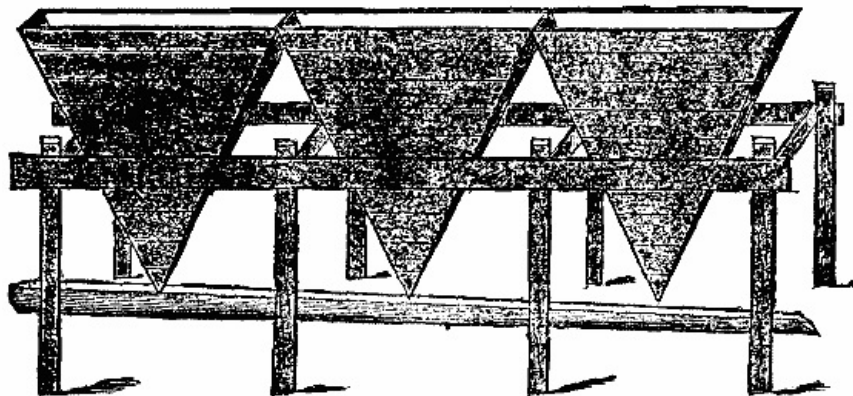

THE TELEMETER SYSTEM.

By F.R. UPTON.

In this paper, read before the British Association, the author explained that the

"Telemeter System," invented by C.L. Clarke, of New York, is a method by which the slow movement of a revolving hand of any indicating instrument may be reproduced by the movement of a similar hand at a distant place, using electricity to convey the impulse. The primary hand moves until it makes electrical contact, thus sending an impulse. It is here that all previous methods have failed. This contact should be absolute and positive, for if it is not, the receiver will not work in unison. The contact could often be doubled by the jarring of the instrument, thus making the receiver jump twice. Clarke has overcome this defect by so arranging his mechanism that the faintest contact in the primary instrument closes two platinum points in multiple arc with it, thus making a firm and positive contact, which is not disturbed by any jar on the primary contact. This gives the instruments a positive start for the series of operations, instead of the faint contact which would be given, for example, by the light and slowly moving hand of a metallic thermometer. The other trouble with previous methods was that the contact points would corrode, and, in consequence of such corrosion, the instrument would fail to send impulses. Corrosion of the contacts is due to breaking the circuit slowly on a small surface. This is entirely remedied by breaking the circuit elsewhere than at the primary contact, using a quick motion, and also by giving this breaking contact large surface and making it firm. The instrument, as applied to a thermometer, is made as follows: From the free end of the light spiral of a metallic thermometer fixed at the other end, an arm, C, is attached, the end of which moves over an arc of a circle when the temperature varies. This end carries on either side of its extremity platinum contacts which, when the thermometer is at rest, lie between two other platinum points, A B, carried on radial arms. Any variation in temperature brings a point on the thermometer arm in contact with one of these points, and thus gives the initial start to the series of operations without opposing any friction to the free motion of the instrument. The first result is the closing of a short circuit round the initial point of contact, so that no current flows through it. Then the magnets which operate one set of pawls come into play. The two contact points are attached to a toothed wheel in which the pawls play, and these pawls are so arranged that they drive the wheel whenever moved by their magnets; thus the primary contact is broken.

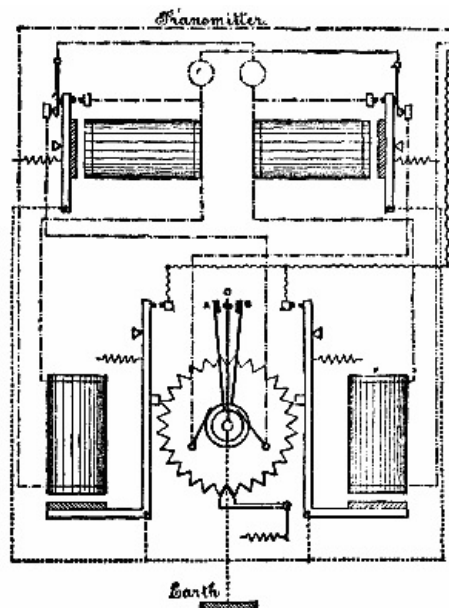

In the receiver there is a similar toothed wheel carrying the hand of the indicating instrument, and actuated at the same moment as the transmitter. The primary contacts are so arranged that the contact is made for each degree of temperature to be indicated. This series of operations leaves the instruments closed and the pawls home in the toothed wheel. To break the circuit another wire and separate set of contacts are employed.

These are arranged on the arms carrying the pawls, and so adjusted that no contact is made until after the toothed wheel has moved a degree, when a circuit is closed and a magnet attracts an armature attached to a pendulum. This pendulum, after starting, breaks the circuit of the magnets which hold the pawls down, as well as of the short-circuiting device. As the pendulum takes an appreciable time to vibrate, this allows all the magnets to drop back, and breaks all circuits, leaving the primary contacts in the same relation as at first. The many details of the instruments are carefully worked out. All the contacts are of a rubbing nature, thus avoiding danger from dirt, and they are made with springs, so as not to be affected by jar.

The receiving instruments can be made recorders also by simple devices. Thus, having only a most delicate pressure in the primary instrument, a distinct ink record may be made in the receiver, even though the paper be rough and soft. The method is applicable to steam gauges, water indicators, clocks, barometers, etc., in fact, to

any measuring instrument where a moving hand can be employed.

A NEW MONSTER REVOLVING BLACK ASH FURNACE AND THE WORK DONE WITH IT.

By **WATSON SMITH**, Lecturer in Chemical Technology in the
Victoria University, etc.

The Widnes Alkali Company, limited, to which I am indebted for permission to describe this latest addition to a family of revolving black ash furnaces, of late not only increasing in number, but also individual size, has kindly allowed my friend, Mr. H. Baker, to photograph the great revolver in question, and I have pleasure now in throwing on the screen a picture of it, and also one of a revolver of ordinary size, so as to render a comparison possible. The revolver of ordinary size measures at most $18\frac{1}{2}$ ft. long, with a diameter of $12\frac{1}{2}$ ft. The boiling down pans connected with such a furnace measure 60 ft. in length. Each charge contains four tons of salt cake, and some of these revolvers get through 18 tons of salt cake per day and consume 13 cwt. of coal per ton of cake decomposed.

With regard to the larger revolver, it may be just said that the Widnes Alkali Company has not at once sprung to the adoption of a furnace of the immense size to be presently given, but in 1884 it erected a revolver only about 3 ft. to 4 ft. short of the length of that one, and having two discharging holes. The giant revolving furnace to be described measures in length 30 ft. and has a diameter of 12 ft. 6 in. Inside length is 28 ft. 6 in., with a diameter of 11 ft. 4 in. It is lined with 16,000 fire bricks and 120 fire-clay blocks or breakers, weighing each $1\frac{1}{4}$ cwt. The bricks weigh per 1,000 about four tons. The weight of salt cake per charge (*i.e.*, contained in each charge of salt cake, limestone, mud, and slack) is 8 tons 12 cwt. For 100 tons of salt cake charged, there are also charged about 110 tons of lime mud and limestone and 55 tons of mixing slack. In a week of seven days about 48 charges are worked through, weighing of raw materials about 25 *tons per charge*. The total amount of salt cake decomposed weekly is about 400 tons, and may be reckoned as yielding 240 tons of 60 per cent. caustic soda. As regards fuel used for firing, this may be put down as 200 tons per week, or about 10 cwt. per ton of salt cake decomposed. Also with regard to the concentration of liquor from 20° Tw. to 50° Tw., there is sufficient of such concentrated liquor evaporated down to keep three self-fired caustic pots working, which are boiled at a strength of 80° Tw. Were it not for this liquor, no less than seven self-fired pots would be required to do this work, showing a difference of 80 tons of fuel.

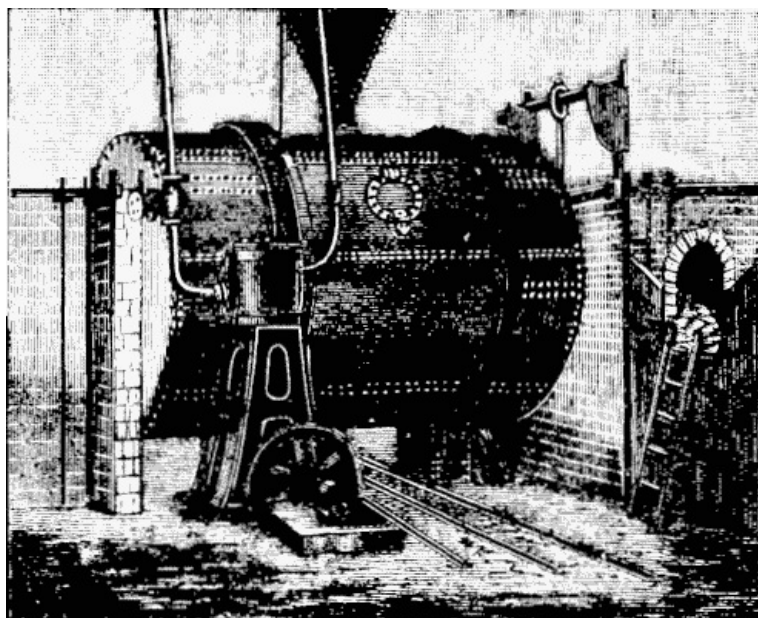

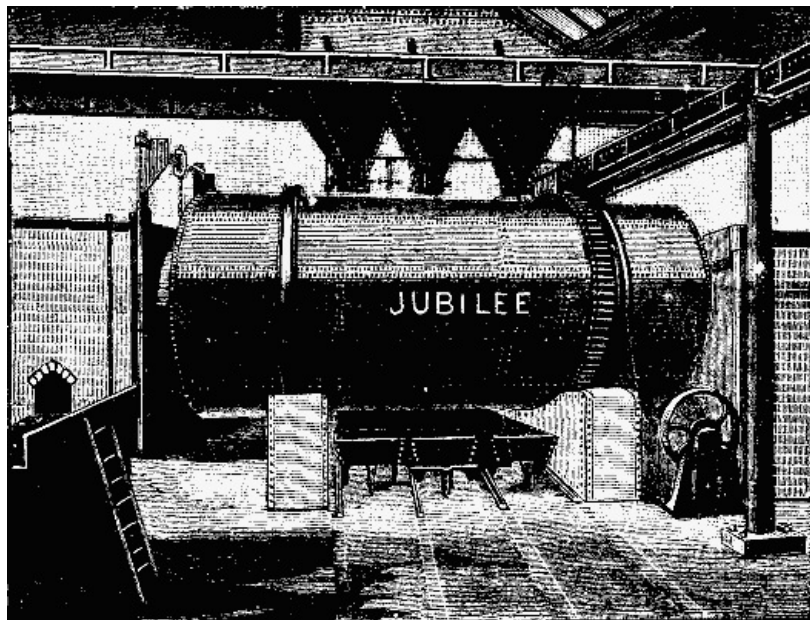

A NEW MONSTER REVOLVING BLACK ASH FURNACE.

The question may be asked, "Why increase the size of these huge pieces of apparatus?" The answer, I apprehend, is that owing to competition and reduction of prices, greater efforts are necessary to reduce costs. With automatic apparatus like the black ash revolver, we may consider no very sensible addition of man power would be needed, in passing from the smallest sized to the largest sized revolver. Then, again, we may, reckoning a certain constant amount of heat lost per each revolver furnace of the small size, consider that if we doubled the size of such revolver, we should lose by no means double the amount of heat lost with the small apparatus; but only the same as that lost in the small furnace *plus* a certain fraction of that quantity, which will be smaller the better and more efficient the arrangements are. Then, again, there is an economy in iron plate for such a large revolver; there is economy in expense on the engine power and on fuel consumed, as well as in wear and tear.

Just to mention fuel alone, we saw that with an ordinary large sized revolver, the coal consumption was 13 cwt. per ton of salt cake decomposed in the black ash process; but with the giant revolver we have been describing, that consumption is reduced to 10 cwt. per ton of cake decomposed.

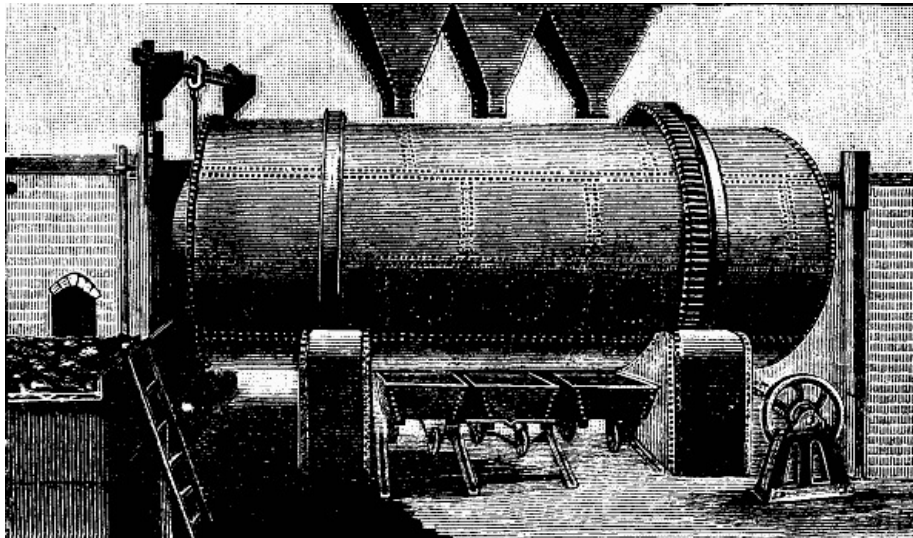

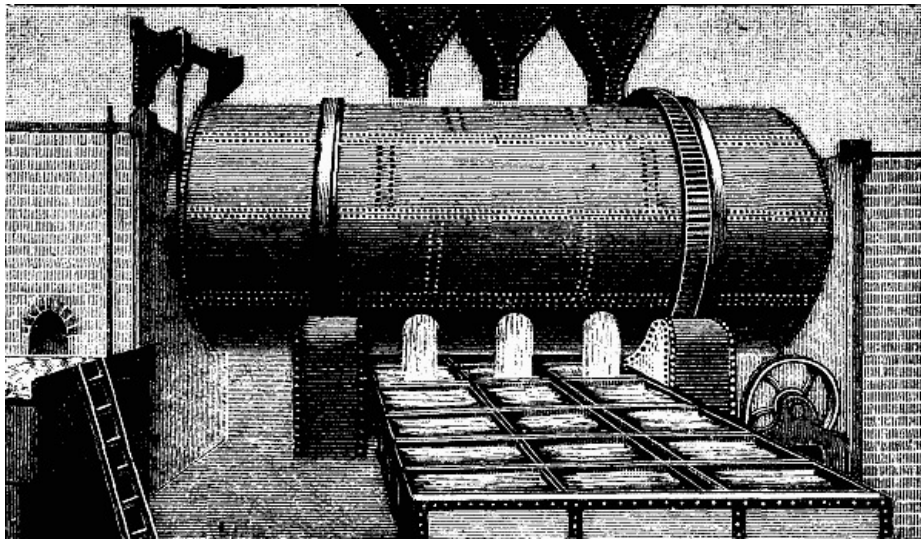

A NEW MONSTER REVOLVING BLACK ASH FURNACE.

The question will be probably asked, How is it possible to get a flame from one furnace to carry through such a long revolver and do its work in fusing the black ash mixture effectively from one end to the other? The furnace employed viewed in front looks very like an ordinary revolver fireplace, but at the side thereof, in line with the front of the revolver, at which the discharge of the "crude soda" takes place, there are observed to be three "charging holes," rather than doors, through which fuel is charged from a platform directly into the furnace through those holes.

The furnace is of course a larger one than furnaces adjusted to revolvers of the usual size. But the effect of one charging door in front and three at the side, which after charging are "banked" up with coal, with the exception of a small aperture above for admission of air, is very similar to that sometimes adopted in the laboratory for increasing heating effect by joining several Bunsen lamps together to produce one large, powerful flame. In this case, the four charging holes represent, as it were, the air apertures of the several Bunsen lamps. Of course the one firing door at front would be totally inadequate to supply and feed a fire capable of yielding a flame that would be adequate for the working of so huge a revolver. As an effort of chemical engineering, it is a very interesting example of what skill and enterprise in that direction alone will do in reducing costs, without in the least modifying the chemical reactions taking place.—*Journal Soc. Chem. Industry.*

IMPROVEMENTS IN THE MANUFACTURE OF PORTLAND CEMENT.¹

By FREDERICK RANSOMS, A.I.C.E.

So much has been said and written on and in relation to Portland cement that further communications upon the subject may appear to many of the present company to be superfluous. But is this really so? The author thinks not, and he hopes by the following communication, to place before this meeting and the community at large some facts which have up to the present time, or until within a very recent date, been practically disregarded or overlooked in the production of this very important and valuable material, so essential in carrying out the great and important works of the present day, whether of docks and harbors, our coast defenses, or our more numerous operations on land, including the construction of our railways, tunnels, and bridges, aqueducts, viaducts, foundations, etc. The author does not propose to occupy the time of this meeting by referring to the origin or the circumstances attendant upon the early history of this material, the manufacture of which has now assumed such gigantic proportions—these matters have already been fully dealt with by other more competent authorities; but rather to direct the attention of those interested therein to certain modifications, which he considers improvements, by means of which a large proportion of capital unnecessarily involved in its manufacture may be set free in the future, the method of manufacture simplified, the cost of manipulation reduced, and stronger and more uniformly reliable cement be placed within the reach of those upon whom devolves the duty and responsibility of constructing works of a substantial and permanent character; but in order to do this it will be necessary to allude to certain palpable errors and defects which, in the author's opinion, are perpetuated, and are in general practice at the present day.

Portland cement is, as is well known, composed of a mixture of chalk, or other carbonate of lime, and clay—such as is obtained on the banks of the Thames or the Medway—intimately mixed and then subjected to heat in a kiln, producing incipient

fusion, and thereby forming a chemical combination of lime with silica and alumina, or practically of lime with dehydrated clay. In order to effect this, the usual method is to place the mechanically mixed chalk and clay (technically called slurry), in lumps varying in size, say, from 4 to 10 lb., in kilns with alternate layers of coke, and raise the mass to a glowing heat sufficient to effect the required combination, in the form of very hard clinker. These kilns differ in capacity, but perhaps a fair average size would be capable of producing about 30 tons of clinker, requiring for the operation, say, from 60 to 70 tons of dried slurry, with from 12 to 15 tons of coke or other fuel. The kiln, after being thus loaded, is lighted by means of wood and shavings at the base, and, as a matter of course, the lumps of slurry at the lower part of the kiln are burned first, but the moisture and sulphurous gases liberated by the heat are condensed by the cooler layers above, and remain until the heat from combustion, gradually ascending, raises the temperature to a sufficient degree to drive them further upward, until at length they escape at the top of the kiln. The time occupied in loading, burning, and drawing a kiln of 30 tons of clinker averages about seven days. It will be readily understood that the outside of the clinker so produced must have been subjected to a much greater amount of heat than was necessary, before the center of such clinker could have received sufficient to have produced the incipient fusion necessary to effect the chemical combination of its ingredients; and the result is not only a considerable waste of heat, but, as always occurs, the clinker is not uniformly burnt, a portion of the outer part has to be discarded as overburnt and useless, while the inner part is not sufficiently burnt, and has to be reburnt afterward. Moreover, the clinker, which is of excessively hard character, has to be reduced by means of a crusher to particles sufficiently small to be admitted by the millstones, where it is ground into a fine powder, and becomes the Portland cement of commerce.

This process of manufacture is almost identical in principle and in practice with that described and patented by Mr. Joseph Aspden in the year 1824; and though various methods have been patented for utilizing the waste heat of the kilns in drying the slurry previous to calcination, still the main feature of burning the material in mass in large and expensive kilns remained the same, and is continued in practice to the present day. The attention of the author was directed to this subject some time since in consequence of the failure of a structure in which Portland cement formed an essential element, and he had not proceeded far in his investigation of the cause of the failure when he was struck with what appeared to him to be the unscientific method adopted in its manufacture, and the uncertain results that must necessarily accrue therefrom. Admitting, in the first place, that the materials employed were considered the best and most economical for the purpose readily accessible, viz., chalk and an alluvial deposit found in abundance on the banks of the Thames and the Medway, and being intimately mixed together in suitable proportions, was it necessary, in order to effect the chemical combination of the ingredients at an intense heat, to employ such massive and expensive structures of masonry, occupying such an enormous space of valuable ground, with tall chimney stacks for the purpose of discharging the objectionable gases, etc., at such a height, in order to reduce the nuisance to the surrounding neighborhood? Again, was it possible to effect the perfect calcination of the interior of the lumps alluded to without bestowing upon the outer portions a greater heat than was necessary for the purpose, causing a wasteful expenditure of both time and fuel? And further, as cement is required to be used in the state of powder, could not the mixture of the raw materials be calcined in powder, thereby avoiding the production of such a hard clinker, which has afterward to be broken up and reduced to a fine powder by grinding in an ordinary mill?

The foregoing are some of the defects which the author applied himself to remove, and he now desires to draw attention to the way in which the object has been attained by the substitution of a revolving furnace for the massive cement kilns now in general use, and by the application of gaseous products to effect calcination, in the place of coke or other solid fuel. The revolving furnace consists of a cylindrical casing of steel or boiler plate supported upon steel rollers (and rotated by means of a worm and wheel, driven by a pulley upon the shaft carrying the worm), lined with good refractory fire brick, so arranged that certain courses are set so as to form three or more radial projecting fins or ledges. The cylindrical casing is provided with two circular rails or pathways, turned perfectly true, to revolve upon the steel rollers, mounted on suitable brickwork, with regenerative flues, by passing through which the gas and air severally become heated, before they meet in the combustion chamber, at the mouth of the revolving furnace. The gas may be supplied from slack coal or other hydrocarbon burnt in any suitable gas producer (such, for instance, as those for which patents have been obtained by Messrs. Brook & Wilson, of Middlesbrough, or by Mr. Thwaite, of Liverpool), which producer may be placed in any convenient situation.

The cement mixture or slurry, instead of being burnt in lumps, is passed between rollers or any suitable mill, when, it readily falls into coarse dry powder, which powder is thence conveyed by an elevator and fed into the revolving furnace by

means of a hopper and pipe, which, being set at an angle with the horizon, as it turns gradually conveys the cement material in a tortuous path toward the lower and hotter end, where it is discharged properly calcined. The material having been fed into the upper end of the cylinder falls through the flame to the lower side of it; the cylinder being in motion lifts it on its advancing side, where it rests against one of its projecting fins or ledges until it has reached such an angle that it shoots off in a shower through the flame and falls once more on the lower side. This again causes it to travel in a similar path, and every rotation of the cylinder produces a like effect, so that by the time it arrives at the lower and hotter end it has pursued a roughly helical path, during which it has been constantly lifted and shot through the flame, occupying about half an hour in its transit.

To some who have been accustomed to the more tedious process of kiln burning, the time thus occupied may appear insufficient to effect the combinations necessary to produce the required result; but it will be seen that the conditions here attained are, in fact, those best suited to carry out effectively the chemical changes necessary for the production of cement. The raw material being in powder offers every facility for the speedy liberation of water and carbonic acid, the operation being greatly hastened by the velocity of the furnace gases through which the particles pass. That such is practically the case is shown by the following analysis of cement so burnt in the revolving furnace or cylinder:

	Per cent.
Carbonic acid, anhydrous	0.40
Sulphuric acid, anhydrous	0.26
Silica soluble	24.68
Silica insoluble	0.60
Alumina and oxide of iron	10.56
Lime	61.48
Magnesia, water, and alkalis	2.02

	100.00

Again, fineness of the particles results in their being speedily heated to a uniform temperature, so that they do not serve as nuclei for the condensation of the moisture existing in the furnace gas. The calcined material, on reaching the lower end of the furnace, is discharged on to the floor or on to a suitable "conveyer," and removed to a convenient locality for cooling and subsequent grinding or finishing. It, however, is not in the condition of hard, heavy clinkers, such as are produced in the ordinary cement kiln, which require special machinery for breaking up into smaller pieces before being admitted between the millstones for the final process of grinding; nor does it consist of an overburnt exterior and an underburnt core or center portion; but it issues from the cylindrical furnace in a condition resembling in appearance coarse gunpowder, with occasional agglutinations of small friable particles readily reduced to fine powder in an ordinary mill, requiring but small power to work, and producing but little wear and tear upon the millstones. The operation is continuous. The revolver or furnace, once started, works on night and day, receiving the adjusted quantity of powdered material at the upper or feed end, and delivering its equivalent in properly burnt cement at the opposite end, thus effecting a great saving of time, and preventing the enormous waste of heat and serious injury to the brickwork, etc., incidental to the cooling down, withdrawing the charge, and reloading the ordinary kiln.

Cement, when taken from the furnace, weighed 110 lb. per bushel. Cement, when ground, leaving 10 percent. on sieve with 2,500 holes to the inch, weighed 121 lb. per bushel, and when cold 118 lb. per bushel. When made into briquettes, the tensile breaking strain upon the square inch:

At 4 days was	410 lb.	per square inch.
At 6 days "	610	"
At 14 days "	810	"
At 49 days "	900	"
At 76 days "	1,040	"

A cylindrical furnace, such as the author has described, is capable of turning out at least 20 tons of good cement per day of twenty-four hours, with a consumption of about 3 tons of slack coal. It will be readily understood that these furnaces can be worked more economically in pairs than singly, as they can be so arranged that one producer may furnish a sufficient quantity of gas for the supply of two cylinders, and the same labor will suffice; but in order to provide for possible contingencies the author advises that a spare gas producer and an extra furnace should be in readiness, so that by a simple arrangement of valves, etc., two cylinders may always be in operation, while from any cause one may be undergoing temporary repairs, and

by this means any diminution in the output may be avoided.

The author considers it unnecessary here to discuss either the advantages or the economy of fuel effected by the employment of gas producers for such a purpose. These have been abundantly proved in steel and glass making industries, where a saving of from 50 to 70 per cent. of the fuel formerly employed has been made. Their cost is small, they occupy little room, they can be placed at any reasonable distance from the place where the gas is to be burnt; any laborer can shovel the slack into them, and they do not require constant skilled supervision. It is claimed by the author of this paper that the following are among the many advantages derivable from the adoption of this method of manufacturing Portland cement, as compared with the old system:

- (1) Economy of space—the furnaces, with their appurtenances, requiring only about one-fourth the space of what would be occupied by the ordinary kilns for producing the same quantity of finished cement.
- (2) Continuous working, and consequent economy of fuel lost by cooling and subsequent reheating of the kiln walls.
- (3) Economy of repairs, which are of a simple and comparatively inexpensive character, and of much less frequent occurrence, as the continuous heat avoids the racking occasioned by the alternate heating and cooling.
- (4) Economy in first cost.
- (5) Economy in grinding, a friable granular substance being produced instead of a hard clinker, whereby crushers are quite abolished, and the wear and tear of millstones greatly reduced.
- (6) Economy of labor, the conveyance to and removal from, the revolving furnace being conducted automatically by mechanical elevators and conveyers.
- (7) Improved quality of the cement, from non-mixture with fuel, ash, or other impurities, and no overburning or underburning of the material.
- (8) Thorough control, from the facility of increasing or diminishing the flow of crushed slurry and of regulating the heat in the furnace as desirable.
- (9) Absence of smoke and deleterious gases.

It is well known that in some localities the materials from which Portland cement is made are of such a powdery character that they have to be combined or moulded into balls or bricks previous to calcination in the ordinary way, thus entailing expense which would be entirely obviated by the adoption of the patent revolving furnace, as has been proved by the author in producing excellent cement with a mixture of slag sand from the blast furnaces of the Cleveland iron district, with a proper proportion of chalk or limestone, which, in consequence of the friable nature of the compound, he was unable to burn in the ordinary cement kiln, but which, when burnt in the revolving furnace, gave the most satisfactory results. The cement so made possessed extraordinary strength and hardness, and it has been a matter of surprise that iron masters and others have not adopted such a means of converting a waste material—which at the present time entails upon its producers constant heavy outlay for its removal—into a remunerative branch of industry by the expenditure of a comparatively small amount of capital. The demand for Portland cement has increased and is still increasing at a rapid ratio. It is being manufactured upon a gigantic scale.

Great interests are involved; large sums of money are being expended in the erection and maintenance of expensive plant for its production; and the author submits that the development of any method which will improve the quality and at the same time reduce the cost of manufacture of this valuable material will tend to increase the prosperity of one of our great national industries, and stimulate commercial enterprise. Works are in progress for manufacturing cement by this improved process, and the author trusts the time is not far distant when the unsightly structures which now disfigure the banks of some of our rivers will be abolished—the present cement kilns, like the windmills once such a common feature of our country, being regarded as curiosities of the past, and cement manufacturers cease to be complained of as causing nuisances to their neighbors.

MIX AND GENEST'S MICROPHONE TELEPHONE.

We illustrate in the annexed engraving the microphone-telephone constructed by Messrs. Mix & Genest, of Berlin, which, after extended trials, has been adopted in preference to others by the imperial postal department of Germany. There are now more than 5,000 of these instruments in use, and we need scarcely mention that the invention has been patented in many countries.

In some microphones a rattling noise is frequently occasioned, which borne along with the sound of the human voice causes an audible disturbance in the telephone. The chief cause of these disturbances may be ascribed to the fact that the carbon rollers in their journals, rest loose in the flutings of the beam, which is fastened to the sound plate. Owing to the shocks given to the entire apparatus, and independent of the oscillations of the sound plate, they are set in motion and roll to and fro in their bearings.

In microphones in which the sound plates are arranged vertically (as shown in Fig. 2), these disturbances assume such a character that there is no possibility of understanding the speaker, for in this case the horizontally directed oscillations of the sound plate, *m*, cause themselves a backward and forward motion on the part of the carbon rollers without increasing or decreasing at the same time the lying-on pressure of the roller journals, and by doing so bring the places of contact one on the other, and thus occasion a conducting resistance of greater or less force. This circumstance serves as an explanation of the reason why the sound plates in Ader's microphones are not arranged vertically, although this way of arranging them offers many advantages over a horizontal or slightly inclined arrangement of the sound plates. Speaking is more convenient in the vertical arrangement, and moreover the plates can be fitted on to instruments better in this way.

All the drawbacks just enumerated and found in Ader's microphones are avoided in the apparatus made by Messrs. Mix & Genest. A sort of braking contrivance operates on the carbon rollers in such a way as to prevent their journals from lying on the lower points in the flutings of the beams. Thus, for instance, if in a microphone with a horizontal sound plate, as illustrated in Fig. 3, the carbon rollers are pressed upward by outward force, it is evident that only a very trifling rolling and disturbing motion can occur, and only small pieces of carbon can be knocked off, which would act injuriously as a secondary contact. The same may be said of the journals of microphones with vertical sound plates, as represented in Fig. 2, when the carbon rollers are pressed in the direction of the arrow, *p*, that is to say, against the sound plate. In this case the journals, *a*, are fixed in the flutings of the beams, *b*, in a direction given them by the power and gravity operating on them, which is clearly represented in the accompanying design, Fig. 2.

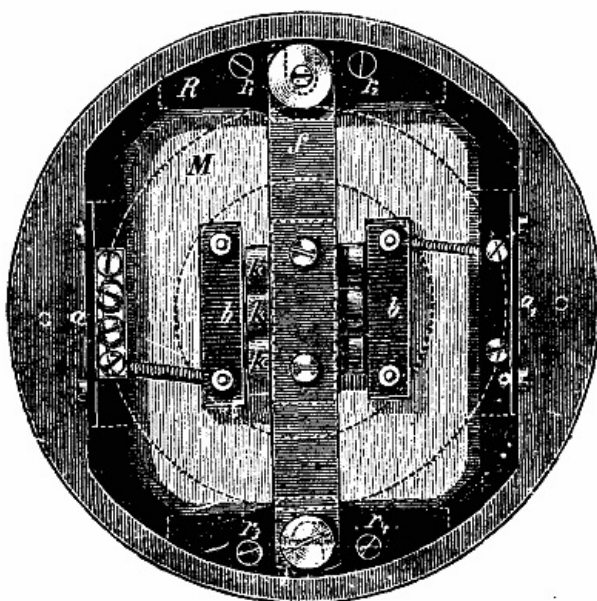

FIG. 1.

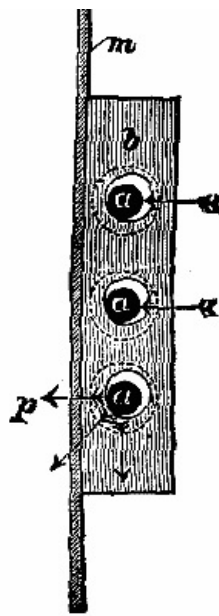

FIG. 2.

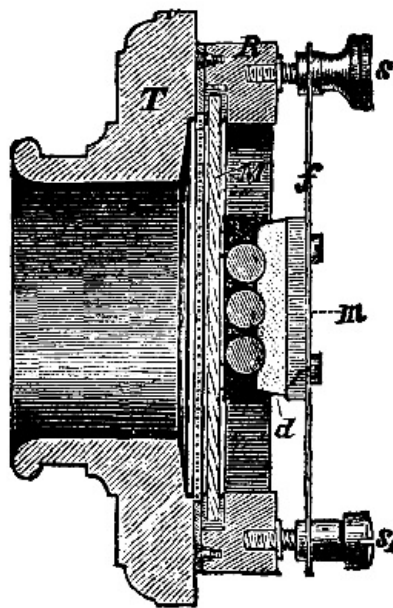

FIG. 3.
THE MIX AND GENEST TELEPHONE.

In all such cases the regulating contrivance applied to brake the carbon rollers in their motion has the result that only the oscillations transmitted from the sound plate on to the contacts come in operation, whereas disturbing mechanical shocks resulting from any outward influences occasion very insignificant vibrations, which are not perceptible in the telephone. The separate contacts thus form a firm system with the sound plate, so that the former are influenced in their motions and effects solely and alone by the shocks and oscillations which operate direct on these sound plates. The roller motion of the carbon is thus removed, and the distinctness of the words spoken is greatly augmented.

The above Figs. 1 and 2 show the microphone in side view and in cross section.

A metal ring, R (see Fig. 1), is fastened by means of the four screws, $r_1 r_2 r_3 r_4$, on a wooden mouthpiece. In a recess of the above ring is the diaphragm, M, which is provided on its outer edge with an India rubber band and is held in position by the two clamps, a and a_1 . The diaphragm is cut out of finely fibered firwood and is well lacquered to preserve it against dampness. On it there are two carbon beams, b , and in the perforations of the latter are the journals of the carbon rollers, k . The alterations in contact take place in the touching points. The cross piece, f , that runs straight across the carbon rollers serves as a braking contrivance, which is regulated as may be necessary by the large projecting screws.

Fig. 3 shows the apparatus in cross section. T is the mouth piece, R the metal ring, M the diaphragm, f the breaking cross piece. On the latter is a metal block fastened by means of two screws. On this metal block is a soft elastic strip (d) of felt or similar material. The letters s and s indicate the regulating screws for the braking contrivance.

The excellent qualities of other microphones, in particular their extreme sensibility for the very least impressions, are undeniable; but it is just this sensibility that is the cause of the complaints made by the public. In practical use this overgreat sensibility proves to be a fault.

In the apparatus constructed by Messrs. Mix and Genest the well-known deficiencies of other systems are avoided. The effect of the sound and the distinctness of the human voice are clearer and far more intelligible. One simple regulation of the microphone suffices for the installation, for there is no danger of its getting out of order. Owing to its peculiar construction, this new microphone is very firm and solid, and for this very reason offers another advantage, namely, the possibility of transmitting sound over very long distances. In the competitive trials instituted by order of the imperial postal department, apparatus of various systems and constructions were subjected to tests, and the apparatus we are speaking of showed the favorable results just mentioned. This microphone has overcome in particular the difficulties connected with the using of combined lines above and below ground, and with the aid of it the excellent telephonic communication is carried on in Berlin, in which city the telephone net is most extensive and complicated. At the same time this microphone transmits the sound over long distances (up to 200 kilom. even) in the most satisfactory manner. Another peculiar advantage of this construction is that it exercises a very small inductive effect on cables and free lines, and consequently the simultaneous speaking on parallel lines causes but little disturbance.

After repeated trials made by the German imperial postal department with the microphones constructed by Messrs. Mix and Genest, these apparatus have been introduced in the place of the telephones and Bell-Blake microphones hitherto used in the telephone service. At present we understand there are about 8,000 of these apparatus in use.

ELECTROLYSIS AND REFINING OF SUGAR.

Mr. G. Fahrig, of Eccles, Lancashire, has invented a new process of refining sugar through electrolysis. The brown sugar is decolorized by means of ozone produced by electric currents of high tension from a dynamo. The electrodes consist of metal grills covered with platinum or some other inoxidizable metal, and are placed in a vat with the intervention of perforated earthenware plates. After being ground and dried in hot air, the crude sugar is placed between the plate and the grills, and the discharges passing between the electrodes produce ozone, which separates the sugar from the coloring matter. To purify the sugar still further, Mr. Fahrig dries it and places it in another vat, with carbon or platinum conducting plates separated by a porous partition. The sugar is placed on one side of this partition, and water circulates on the other side.

The current from a dynamo of feeble tension is sent through the vat between the plates. The water carries along the impurities separated by the current, and the sugar is further whitened and refined.

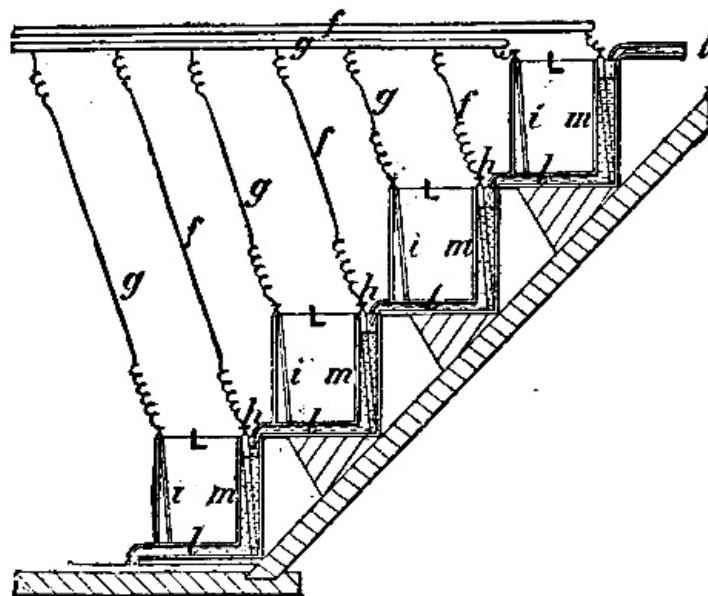

The accompanying figure shows a series of four vats arranged one above another, in order to permit the water to circulate. Here *i* and *h* represent the plates connected with the poles of the dynamo through the conductors, *f* and *g*; *m* represents the porous partition; *L*, the spaces filled with sugar; and *l*, the compartments in which the water circulates.—*La Lumiere Electrique*.

A CURRENT METER.

We give a description of a meter we made in June, 1883. You will find a cross section of the meter and also a printed dial we had made at the time. We called it an ampere register, but no doubt we would give it a better name to-day. The meter consisted of a glass tube, *c*, both ends of which were fitted into two bent pieces of piping, D and F, as shown. Through these bent tubes, D and F, passed the wires, *a* and *b*, which were connected to the binding posts, A and B. The part of the wire where it passed into the tubes was well insulated. At the ends, *a'* and *b'*, was connected the coil, R, which consisted simply of a few turns of copper wire whose diameter was less than the leading wires, *a* and *b*. To the tube, D, was attached a square tube, E, which had a little opening at the top so as to permit a small undershot wheel, I, to revolve freely. This undershot wheel was well pivoted and constructed very light. To the axis of this wheel was connected another system of wheels with indicators, as shown, J. Now the tubes, E and F, were connected to a reservoir, G. This reservoir consisted of a square tank, in the inside of which were soldered in an alternating manner square sheets of copper as shown in the drawing, *g g' g'' g'''* ... These sheets acted as diffusers. These plates or sheets presented a very large surface. On the outside of the tank, G, were also diffusers, *h h'* ... arranged all round and presenting an appearance as if two books were open so as to form a square with their covers, the leaves being the diffusers. The diffusers on the outside were at right angles to those inside.

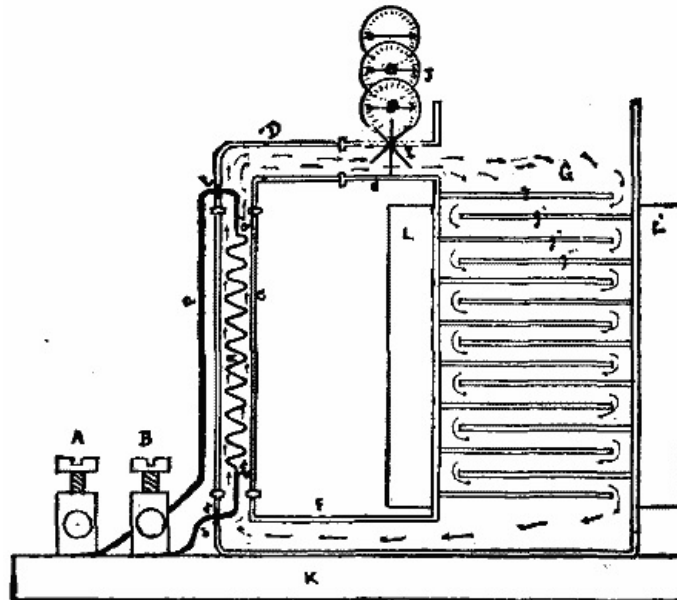

CROSS SECTION OF JEHL AND RUPP'S CURRENT METER.

The action of the meter was thus: When a current passes through the coil, R, it heats the liquid at the place, thus causing a circulation, the warm liquid ascending while the cold liquid descends as shown by the arrows. This circulation causes the undershot wheel to revolve, and its revolutions are registered by the clockwork. The stronger the current, the more the heat, and thus the more rapid the circulation. The warm liquid once in the tank, which is of a reasonable size, will impart its heat to all the diffusers. The surface of the glass tube, etc., is very small in comparison to the surface of the tank. It will be seen that the function of this apparatus is independent of the outward temperature, for the motion of the liquid is due only to that heat which is generated by the current. When the current does not pass, it is evident that the liquid, at whatever temperature it may be, does not circulate, as all parts are of the same temperature; but the moment the current passes, a difference is produced, which causes a circulation in proportion to the current. We may mention that we tried various liquids, and give preference to pure olive oil. It will also be seen that this meter is good for alternating currents. In conclusion, we may remark that the tests we made gave satisfaction, and we wanted to publish them, but that Mr. Jehl was called away to fit up the Edison exhibit in the Vienna exhibition for the Societe Electrique Edison of Paris. After the exhibition we began our work upon our disk machine, and had almost forgotten our meter. The whole apparatus is mounted on a base, K.

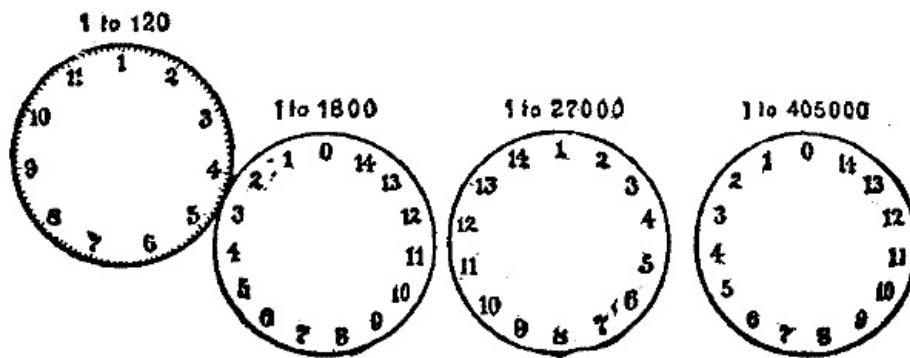

DIAL FACE.

JEHL AND RUPP.

Brünn, Sept. 26, 1887.

STORAGE BATTERIES FOR ELECTRIC LOCOMOTION.¹

By A. RECKENZAUN.

The idea of employing secondary batteries for propelling vehicles is almost contemporaneous with the discovery of this method of storing energy. To Mr. Plante, more than to any other investigator, much of our knowledge in this branch of electrical science is due. He was the first to take advantage of the action of secondary currents in voltaic batteries. Plante is a scientist of the first grade, and he is a wonderfully exact experimenter. He examined the whole question of polarization of electrodes, using all kinds of metal as electrodes and many different liquids as electrolytes, and during his endless researches he found that the greatest useful effect was produced when dilute sulphuric acid was electrolyzed between electrodes of metallic lead.

A set of Plante's original cells was exhibited for the first time in March, 1860, before the Paris Academy of Sciences. Scientists admired and praised it, but the general public knew nothing of this great discovery thus brought to notice. Indeed, at that period little commercial value could be attached to such apparatus, since the accumulator had to be charged by means of primary batteries, and it was then well known that electrical energy, when produced by chemical means in voltaic cells, was far too expensive for any purpose outside the physical laboratory or the telegraph office.

It was twenty years after this exhibition at the Academy of Sciences in Paris that public attention was drawn to the importance of storage batteries, and that Mr. Faure conceived the idea of constructing plates consisting of lead and oxides of lead. At that time the advantages accruing through a system of electrical storage could be fully appreciated, since electrical energy was already being produced by mechanical means through the medium of dynamo-electric machines.

It was the dynamo machine which created the demand for the storage battery, and the latter was introduced anew to the public at large and to the capitalist with great pomp and enthusiasm. One of Faure's accumulators was sent to Sir William Thomson, and this eminent scientist in the course of experiments ascertained that a single cell, weighing 165 lb., can store two million foot-pounds of energy, or one horse power for one hour, and that the loss of energy in charging did not exceed 15 per cent. These results appeared highly encouraging. There we had a method of storing that could give out the greater part of the energy put in. The immense development which the electric transmission of energy was even at that early day expected to undergo pointed to the fact that a convenient method of receiving large quantities of transmitted energy, and of holding it in readiness until wanted, must be of the highest importance. Numerous applications of the Faure battery were at once suggested, and the public jumped to the conclusion that a thing for which so many uses could be instantly found must necessarily be a profitable investment, and plenty of money was provided forthwith, not with the idea of commencing careful experiments and developing the then crude invention, which would have been the correct thing, but for manufacturing tons of accumulators in their first and immature form.

I need not describe the disappointments which followed the first unfulfilled hopes, nor repeat the criticism that was heaped upon the heads of the early promoters. Those early hopes were untimely and unreasonable. A thousand difficulties had to be

overcome—scientific difficulties and manufacturing difficulties. This invention, like most others, had to go through steady historical developments and evolution, and follow the recognized laws of nature, which are against abnormal and instantaneous maturity. The period of maturity has also been retarded by injudicious treatment, but the ultimate success was inevitable. Great advances have been made within the last few years, and I propose now to offer a few facts and figures relating to the present state of the subject with reference to the application of storage batteries to locomotive purposes. It is not within the province of this paper to discuss all the different inventions of secondary batteries nor to offer any suggestions with regard to priority, therefore I will confine myself to general statements. I am aware of the good work that was done in the United States by Kirchoff twenty-six years ago, and of the more recent work of Mr. Brush, of Cleveland, Mr. Julien and others, but I am more particularly acquainted with the recent achievements of the Electrical Accumulator Company, who own the rights of the Electrical Power Storage Company, of London. I have used the batteries of the latter company for propelling electric boats and electric street cars. The first of the boats was the *Electricity*, which was launched in September, 1882, and which attained a speed of seven miles an hour for six consecutive hours. Since then a dozen electric boats of various sizes have been fitted up and worked successfully by means of storage batteries and motors of my design. The most important of these were the launch *Volta* and another similar craft, which is used by the Italian government for torpedo work in the harbor of Spezia. On the measured mile trial trips the Italian launch gave an average speed of 8.43 miles an hour with and against the tide. The hull of this vessel was built by Messrs. Yarrow & Co., and the motors were manufactured by Messrs. Stephens, Smith & Co., of London. The *Volta*, which was entirely fitted by the latter firm, is 37 feet long and 7 feet beam. She draws 2'6" of water when carrying 40 persons, for whom there is ample sitting accommodation. There are 64 cells in this boat. These are placed as ballast under the floor, and actuate a pair of motors and a screw coupled direct to the armature shaft running at 700 revolutions a minute. We crossed the English Channel with this boat in September of last year, leaving Dover at 10:40 in the morning, arriving at Calais at 2:30 P.M.; stayed about an hour in the French harbor for luncheon and floated into Dover docks the same evening, at 6:30, with full speed. The actual distance traversed without entirely discharging the cells was 54 miles. The current remained constant at 28 amperes until 5 P.M., and it only dropped to 25 amperes at the completion of the double voyage between England and France. Several electric launches are now being constructed in London, and one in New York by the Electrical Accumulator Company.

M. Trouve exhibited a small boat and a tricycle, both worked by Plante accumulators, at Paris, in 1881.

The first locomotive actuated by storage batteries was used at a bleaching works in France in 1882. During the same year I designed an electric street car for the storage company, and this was tried on the lines of the West Metropolitan Tramways in March, 1883. It had accommodation for 46 passengers. This car had many defects, and I reconstructed it entirely, and ran it afterward in its improved form on the South London Tramways, and also on a private track at Millwall, where it is now in good condition, and I have a similar car in Berlin. M. Phillipart exhibited a car in Paris and M. Julien made successful experiments in Brussels, Antwerp, and Hamburg. Mr. Elieson is running storage battery locomotives in London. Mr. Julien has also been experimenting with a car in New York, and I believe one is in course of construction for a line in the city of Boston. Messrs. W. Wharton, Jr. & Co. have a storage battery car running at Philadelphia on Spruce and Pine streets, and this energetic firm is now fitting up another car with two trucks, each carrying an independent motor, similar to my European cars.

I have mentioned all these facts in order to show that there is a considerable amount of activity displayed in the matter of storage batteries for street cars, and that continued and substantial progress is being made in each successive case. The prejudices against the application of secondary batteries are being rapidly dispelled, and there are indications everywhere that this method of propulsion will soon take a recognized place among the great transit facilities in the United States. I feel convinced that this country will also in this respect be far ahead of Europe before another year has passed over our heads.

There are several popular and I may say serious objections to the employment of storage batteries for propelling street cars. These objections I will now enumerate, and endeavor to show how far they are true, and in what measure they interfere with the economical side of the question.

First objection: The loss of energy, which amounts in practice to 20 and sometimes 30 per cent. Now, every method of storing or transmitting energy involves some waste, but in saying this we need not condemn the system, for after all the term efficiency is only a relative one. For instance, a 10 horse power steam engine consumes three times as much fuel per horse power hour as a 1,000 horse power

engine does, yet this small engine must be, and is regarded as, one of the most economical labor-saving appliances known to us. Considered as a heat engine, the efficiency of the most economical steam motor is but ten per cent.—90 per cent of the available units of heat contained in coal being lost during its transformation into mechanical energy. Thus, if we find that the storage battery does not return more than 70 per cent, of the work expended in charging it, we ought not to condemn it on that account until we have ascertained whether this low efficiency renders the system unfit for any or all commercial purposes. It is needless to go into figures in order to show that, when compared with animal power, this objection drops into insignificance.

The second, more formidable, objection relates to the weight of storage batteries—and this involves two disadvantages, viz., waste of power in propelling the accumulator along with the car, and increased pressure upon the street rails, which are only fitted to carry a maximum of 5 tons distributed over 4 points, so that each wheel of an ordinary car produces a pressure of 1¼ tons upon a point of the rail immediately under it.

The last mentioned objection is easily overcome by distributing the weight of the car with its electrical apparatus over 8 wheels or 2 small trucks, whereby the pressure per unit of section on the rails is reduced to a minimum. With regard to the weight of the storage batteries, relatively to the amount of energy the same are capable of holding and transmitting, I beg to offer a few practical figures. Theoretically, the energy manifested in the separation of one pound of lead from its oxide is equivalent to 360,000 foot pounds, but these chemical equivalents, though interesting in themselves, gives us no tangible idea of the actual capacity of a battery.

Repeated experiments have shown me that the capacity of a secondary battery cell varies with the rate at which it is charged and discharged. For instance, a cell such as we use on street cars gave a useful capacity of 137.3 ampere hours when discharged at the average rate of 45.76 amperes, and this same cell yielded 156.38 ampere hours when worked at the rate of 22.34 amperes. At the commencement of the discharge the E.M.F of the battery was 2.1 volts, and this was allowed to drop to 1.87 volts when the experiment was concluded. The entire active material contained in the plates of one cell weighed 11.5 lb., therefore the energy given off per pound of active substance at the above high rate of discharge was 62.225 foot pounds, and when discharging at the lower rate of 22.34 amperes the available useful energy was 72.313 foot pounds, or nearly 2.2 electrical horse power per pound of active matter. But this active substance has to be supported, and the strength or weight of the support has to be made sufficiently great to give the plate a definite strength and durability. The support of the plates inclusive of the terminals above referred to weighs more than the active material, which consists of peroxide of lead and spongy lead; so that the plates of one cell weigh actually 26.5 pounds. Add to this the weight of the receptacle and acid, and you get a total of about 41 pounds per cell when in working order. Seventy of these cells will propel an ordinary street car for four hours and a half, while consuming the stored energy at the rate of 30 amperes, or over 5.6 electrical horse power. The whole set of seventy cells weighs 2,870 lb., which is barely one-fifth of the entire weight of the car when it carries forty adult passengers. Therefore the energy wasted in propelling the accumulator along with a car does not amount to more than 20 per cent. of the total power, and this we can easily afford to lose so long as animal power is our only competitor. From numerous and exhaustive tests with accumulators on cars in this country and abroad, I have come to the conclusion that the motive power for hauling a full-sized street car for fifteen hours a day does not exceed \$1.75, and this includes fuel, water, oil, attendance, and repairs to engine, boiler, and dynamo. We have thus an immense margin left between the cost of electric traction and horse traction, and the last objection, that relating to the depreciation of the battery plates, can be most liberally met, and yet leave ample profits over the old method of propulsion by means of animals.

The advantages of storage battery street cars for city traffic are self-evident, so that I need not trouble you with further details in this respect, but I would beg those who take an interest in the progress of the electric locomotive to give this subject all the consideration it deserves, and I would assure them that the system which I have advocated in this brief but very incomplete sketch is worthy of an extended trial, and ready for the purposes set forth. There is no reason why those connected with electric lighting interests in the various cities and towns should not give the matter their special attention, as they are the best informed on electrical engineering and already have a local control of the supply of current needed for charging.

In the car which we use in Philadelphia there are actually 80 cells, because there are considerable gradients to go over. Each cell weighs 40 pounds and the average horse power of each battery is six. Sometimes we only use two horse power and sometimes, going up grades of 5 per cent., we use as much as 12 horse power, but the average rate is 6 electrical horse power. With reference to the weight of passengers on the cars, we have never carried more than 50 passengers on that car, because it is

impossible to put more than 50 men into it. There are seats for 24, and the rest have to stand on the platforms or in the aisle.

The changing of the batteries takes three minutes with proper appliances. One set of cells is drawn out by means of a small winch and a freshly charged set is put in. It takes the same time to charge the battery as it does to discharge it in the working of the cars, so one reserve set would be sufficient to keep the car continually moving.

The loss of energy from standing about is probably nothing. If a battery were to stand charged for three months in a dry case, the loss of energy might be in three months 10 per cent. I purposely had a set of cells standing for two years charged and never used them. After two years there was still a small amount of energy left. So as regards the loss of energy in a battery standing idle, it is practically nothing, because no one would think of charging a battery and letting it stand for three months or a year.

I have had them stand three or four months and I could hardly appreciate the loss going on, provided always that the cells are standing on a dry floor. If the exterior of the box be moist, or if it stands on a moist floor, there will naturally be a surface leakage going on: but where there is no surface leakage the mere local action between the oxides and metallic lead will not discharge the battery for a very considerable time.

I have made experiments in London with a loaded car pulled by two horses. I put a dynamometer between the attachment of the horse and the car, so as to ascertain exactly the amount of pull, measured in pounds multiplied by the distance traversed in a minute. You will be surprised to know that two horses, when doing their easiest work, drawing a loaded car on a perfectly level road, exert from two to three horse power. I have mentioned a car in Philadelphia where we use between two and twelve horse power. A horse is capable of exerting eight horse power for a few minutes, and when a car is being driven up grades, such as I see in Boston, for instance, pulling a load of passengers up these grades, the horses must be exerting from 12 to 16 horse power, mechanical horse power. That is the reason that street car horses cannot run more than three or four hours out of the twenty-four. If they were to run longer, they would be dead in a few weeks. If they run two hours a day, they will last three or four years.

The life of the cells must be expressed upon the principle of ampere hours or the amount of energy given off by them. Street car service requires that the cells work their hardest for fifteen or sixteen hours a day. The life of the cells has to be divided; first, into the life of the box which contains the plates. This box, if appropriately constructed of the best materials, will last many years, because there is no actual wear on it. The life of the negative plates will be very considerable, because no chemical action is going on in the negative plate. The negative plate consists almost entirely of spongy lead, and the hydrogen is mechanically occluded in that spongy lead. Therefore the depreciation of the battery is almost entirely due to the oxidation of the positive plates. If we were to make a lead battery of plates $\frac{1}{4}$ inch thick, it would last many years; but for street car work that would be far too heavy. Therefore we make the positive plates a little more than one-eighth of an inch thick. I find that the plates get sufficiently brittle to almost fall to pieces after the car has run fifteen hours a day for six months. The plates then have to be renewed. But this renewal does not mean the throwing away of the plates. The weight is the same as before, because no consumption of material takes place. We take out peroxide of lead instead of red lead. That peroxide, if converted, produces 70 per cent. of metallic lead, so that there is a loss of 30 per cent. in value. Then comes the question of the manufacture of these positive plates, which, I believe, at the present day are rather expensive. But I believe the time will come when battery plates will be manufactured like shoe nails, and the process of renewing the positive plates will be a very cheap one.

I ascertained in Europe that the motive power costs 2 cents per car mile; that is, the steam power and attendance for charging the batteries. We have to allow twice as much for the depreciation of a battery at the present high rate at which we have to pay for the battery—\$12 for each cell. But I believe that as soon as the storage battery industry is sufficiently extended, the total cost for propelling these cars will not be more than six cents a mile, or about one half the cost of the cheapest horse traction.

I have made some very careful observations on the cable tramway in Philadelphia, which is quite an extensive system. I have never been able to ascertain the exact amount of waste in pulling the cable itself; but I have it on the authority of certain technical papers that there is a waste of about eighty per cent. I do not intend to depreciate cable or any other tramways, but there is a difficulty about introducing cable tramways. It is necessary to dig up the streets and interfere with the roadways. I have been told that the cable arrangements in Philadelphia cost \$100,000 a mile, and that the cable road in San Francisco cost more than that. One of the directors of

the cable company in Philadelphia told me that if he had seen the battery system before the introduction of the cable, he would probably have made up his mind in favor of the former. The wear and tear in the case of the storage system is also considerable. There is a waste of energy in the dynamo; secondly, in the accumulator charged by that dynamo; thirdly, in the motor which is driven by the accumulator; and fourthly, in the gearing that reduces the speed of the motor to the speed required by the car axles. It would be difficult to make a motor run at the rate of eighty revolutions per minute, which is the number of revolutions of the street car axle when running at the rate of ten miles an hour. Take all these wastes, and you find in practice that you do not utilize more than 40 per cent. of the energy given by the steam engine. But this is quite sufficient to make this system much cheaper than horse traction.

It is well known that we can discharge the storage battery *ad libitum* at the rate of 2 amperes or 200 amperes. I can get out of a storage battery almost any horse power I like for a short space of time. I have not the least objection to the direct system. But when you come to run twenty or thirty or fifty cars on one line, you will require very large conductors or dangerously high electromotive force. The overhead system is applicable to its own particular purposes. Where there are only five or ten, or even twenty, cars running on one line, and that line runs through a suburb or a part of a city where there are not many houses, that system is to be preferred. The objection to the overhead system is not so much the want of beauty, but the want of practicability. You have to put your posts very high indeed, so as to let great wagon loads of hay and all sorts of things pass underneath. Most of the trouble comes in winter, and when it is snowing hard a great many difficulties arise. As regards the loss, suppose that the resistance of the overhead lines is one ohm. To draw one car it will take an average of 20 amperes, and the only loss will be 20 multiplied by 20, that is, 400 watts through line resistance. But if there are ten cars on that line, you get 40,000 watts loss of energy, unless you increase the conductor in proportion to the number of cars. If you do that, you get an enormous conductor, and have a sort of elevated railroad instead of a telegraph wire, as most people imagine an overhead conductor to be.

The current required to run a street car is about thirty amperes, and an electromotive force of about 180 volts. If cars are run in connection with an incandescent light station, we can arrange our apparatus so that we can use an E.M.F. say of 110 volts, and then we can put in a smaller number of cells with a larger capacity that will give a corresponding horse power. We can charge such larger cells with 50 or 60 amperes instead of thirty.

In regard to arc lighting machinery, the arc lighting dynamo should not be used to charge the accumulators. They can be used, but they require such constant attention as to make them impracticable. We can only use shunt-wound dynamos conveniently for that purpose.

In regard to using two motors on a car, there are several advantages in it. I use two motors on all my cars in Europe, and always have done so from the beginning. One of the advantages is that in case of an accident to one motor the other will bring the car home; secondly, with two motors we can vary the speed without changing the E.M.F. of the battery. If I want very much power, I put two motors in parallel, getting four times the power that I do with one machine, and an intermediate power of two motors.

There is another advantage of having two motors, and that is that we can use two driving axles instead of one, and we can go up grades with almost double the facility that way, because the adhesion would be double. These are the main advantages arising from the use of two or more motors.

Mr. Mailloux asked if I would give my experience in regard to the mechanical transmission between the motor and the car axle. I have used almost everything that was known at the time, but in order to give you a full and detailed account of the various modes of transmission which I have used I should have to give you figures to bear out certain experiments. I should only be able to do that in a lecture of at least five hours' duration, so I hope that you will kindly excuse me on that point.

With regard to the durability of plates, I have taken into consideration fifteen hours a day. In regard to the application of electrical brakes, I will say that that was one of the first ideas that entered my head when I began to use electric motors, and other people had that idea long before me. I have used an electric brake, using the motor itself as a brake—that is, as the car runs down a grade by momentum, it generates a current, but this current cannot be used for recharging a battery. It is utter nonsense to talk about that unless we have a steady grade four or five miles long. The advantages are very small indeed, and the complications which would be introduced by employing automatic cut-outs, governors, and so on, would counterbalance anything that might be gained. As regards going up an incline, of course stopping and starting again has to be done often, and anybody who at any time works cars by

electricity, whether they have storage batteries or not, has to allow for sufficient motive power to overcome all the difficulties that any line might present.

One of the great mistakes which some of the pioneers in this direction made was that they did not put sufficient power upon the cars. You always ought to put on the cars power capable of exerting perhaps 20 to 40 per cent. more than is necessary in the ordinary street service, so that in case of the road being snowed up, or in the case of any other accident which is liable to occur, you ought to have plenty of power to get out of the scrape.

[1]

From a paper read before the National Electric Light Association, New York, August, 1887.

BRISTOL CATHEDRAL.

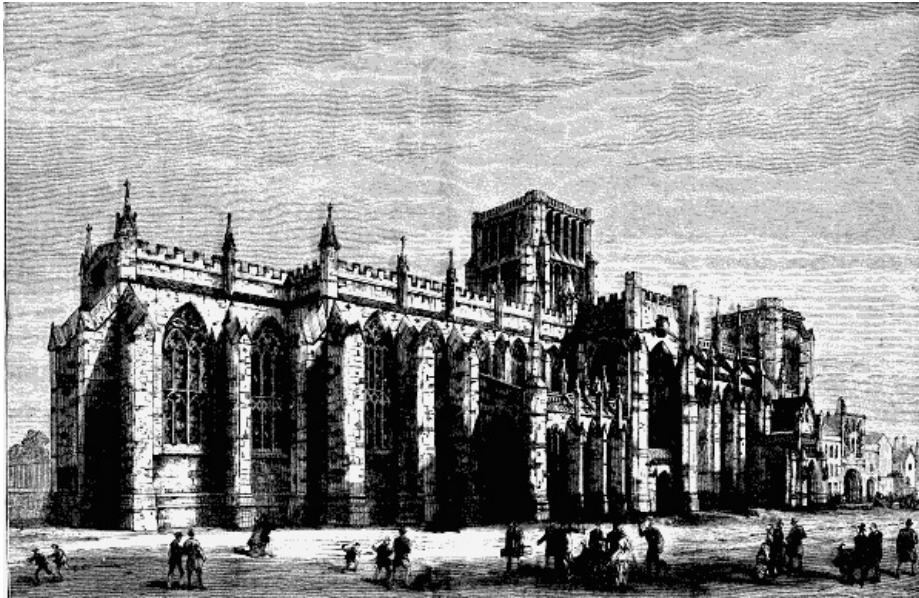

BRISTOL CATHEDRAL.

An Augustinian monastery, founded by Robert Fitzhardinge in 1142, had its church, of Norman architecture, to which additions were made in the early English period. When Edmund Knowle was abbot, from 1306 to 1332, the Norman choir was replaced by that which now exists. His successor, Abbot Snow, built the chapels on the south side of the choir. Abbot Newland, between 1481 and 1515, enriched the transepts with a groined roof and with ornamental work of the decorated Gothic style, and erected the central tower. Abbot Elliott, who followed Newland, removed the Norman nave and aisles, intending to rebuild them; but this was prevented by his death in 1526 and by the dissolution of the monastery a few years afterward; he completed, however, the vaulting of the south transept. The church remained with a nave, and otherwise incomplete, until the modern restorations; after which, in 1877, it was reopened with a special service. Messrs. Pope & Bindon, of Bristol, were the architects employed. The exterior, of which we give an illustration, viewed from St. Augustine's Green, or Upper College Green, is not very imposing; from the Lower Green there is a good view of the central tower and the transept. The height of the tower is but 127 ft. It is of perpendicular Gothic architecture, but the piers supporting it are Norman. The interior presents many features of interest. The clustered triple shafts of the piers in the choir, with their capitals of graceful foliage, the lofty pointed arches between them, and the groined vaulting, have much beauty. The chancel is decorated with tracery of a peculiar pattern.

The Abbey of St. Augustine at Bristol was surrendered to King Henry VIII. in 1538, and became, in 1542, the cathedral of the new Episcopal see then created. The first Bishop of Bristol, Paul Bush, was deprived of his see by Queen Mary, being a married clergyman and refusing to part with his wife. Bishop Fletcher, in Queen Elizabeth's time, afterward Bishop of Worcester and of London, was twice married, at which this queen likewise expressed her displeasure. He was father of Fletcher, the dramatic poet; and he is said to have been one of the first English smokers of tobacco. Among noted Bishops of Bristol were Bishop Lake, afterward of Chichester, and Bishop Trelawny (Sir Jonathan Trelawny, Bart., of Cornwall), two of the "seven bishops"; imprisoned for disobeying an illegal order of James II. "And shall Trelawny die? Then twenty thousand Cornishmen will know the reason why." But the most eminent was Bishop Joseph Butler, the author of "The Analogy of Natural and Revealed Religion" and of the "Sermons on Human Nature." He was born at Wantage, in Berkshire, and

was educated as a Nonconformist. He was Bishop of Bristol from 1738 to 1750, when he was translated to Durham. In 1836, the see of Bristol was joined with that of Gloucester; and the Right Rev. Drs. J.H. Monk, O. Baring, W. Thomson (now Archbishop of York), and C.J. Ellicott have been Bishops of Gloucester and Bristol. —*Illustrated London News*.

WAVES.

In the first days of August, two startling announcements reached us from the United States. They were as follows:

(1.) "The commander of the Cunarder Umbria reports that at 3 o'clock on July 27, about 1,500 miles from Sandy Hook, the vessel was struck by a tidal wave 50 ft. high, which swept the decks, carried away a portion of the bridge and the forward hatch, and flooded the cabins and steerage."

(2.) "The captain of the Wilson line steamer Martello reports that at half-past 8 on the evening of July 25, when in lat. 49° 3' N., long. 31° W., an enormous wave struck the vessel, completely submerging the decks."

In view of these reports, and inasmuch as questions were asked on the subject in Parliament, though it is quite possible that, as regards the "tidal" character of the waves, there may be something of newspaper *gobemouche* in the announcements, we offer a few remarks on *waves* in general, which may be useful to some of our readers.

Tidal phenomena present themselves under two aspects: as alternate elevations and depressions of the sea and as recurrent inflows and outflows of streams. Careful writers, however, use the word *tide* in strict reference to the *changes of elevation* in the water, while they distinguish the recurrent streams as *tidal currents*. Hence, also, *rise* and *fall* appertain to the tide, while *flood* and *ebb* refer to the tidal current.

The *cause of the tides* is the combined action of the sun and moon. The relative effects of these two bodies on the oceanic waters are directly as their mass and inversely as the square of their distance; but the moon, though small in comparison with the sun, is so much nearer to the earth that she exerts the greater influence in the production of the great *tide wave*. Thus the mean force of the moon, as compared with that of the sun, is as $2\frac{1}{4}$ to 1.

The attractive force of the moon is most strongly felt by those parts of the ocean over which she is vertical, and they are, consequently, drawn toward her. In the same manner, the influence of the luminary being less powerfully exerted on the waters furthest from her than on the earth itself, they must remain behind. By these means, at the two opposite sides of the earth, in the direction of the straight line between the centers of the earth and moon, the waters are simultaneously raised above their mean level; and the moon, in her progressive westerly motion, as she comes to each meridian in succession, causes two uprisings of the water—two high tides—the one when she passes the meridian above, the other when she crosses it below; and this is done, not by drawing after her the water first raised, but by raising continually that under her at the time; this is the *tide wave*. In a similar manner (from causes already referred to) the sun produces two tides of much smaller dimensions, and the joint effect of the action of the two luminaries is this, that instead of four separate tides resulting from their separate influence, the *sun merely alters the form of the wave raised by the moon*; or, in other words, the greater of the two waves (which is due to the moon) is modified in its height by the smaller (sun's) wave. When the summit of the two happens to coincide, the summit of the combined wave will be at the highest. When the hollow of the smaller wave coincides with the summit of the larger, the summit of the combined wave will be at the lowest.

It is necessary to have a clear and distinct conception of the difference between the *motion* of a *wave* and that of a *current*. In the current there is a transfer of water; in the wave the transfer is no more than would be brought about by a particle of water impinging on another where that particle has a motion perpendicular to the surface, and a rising and falling results. The onward movement of the wave itself is always perceptible enough. That the water is not moving with the same velocity is also evident from watching the progress of any light body floating on its surface. This fact may be practically illustrated in the case of a ship at sea, sailing before the wind in the same direction as the waves are moving. When the crest of a wave is near the stern, drop a piece of wood on it. Almost instantly the wave will be seen shooting ahead of the vessel, while the wood is scarcely removed from the position where it fell on the water. The wave has moved onward, preserving its identity as a wave, the water of which it is formed being constantly changed; and thus the motion of the wave is one thing, that of the water in which the waves are formed is quite another thing.

Again, waves are formed by a force acting horizontally; but in the case of the tide wave, that force acts uniformly from the surface to the lowest depths of the ocean, and the breadth of the wave is that curved surface which, commencing at low water, passes over the summit of the tide down to the next low water—this is a wave of the first order. In waves of the second order, the force raising them acts only on the surface, and there the effect is greatest (as in the wind waves)—where one assists in giving to the water oscillating motion which maintains the next, and gradually puts the whole surface in commotion; but at a short distance down that effect entirely disappears.

If the earth presented a uniform globe, with a belt of sea of great and uniform depth encircling it round the equator, the tide wave would be perfectly regular and uniform. Its velocity, where the water was deep and free to follow the two luminaries, would be 1,000 miles an hour, and the height of tide inconsiderable. But even the Atlantic is not broad enough for the formation of a powerful tide wave. The continents, the variation in the direction of the coast line, the different depths of the ocean, the narrowness of channels, all interfere to modify it. At first it is affected with only a slight current motion toward the west—a motion which only acquires strength when the wave is heaped up, as it were, by obstacles to its progress, as happens to it over the shallow parts of the sea, on the coasts, in gulfs, and in the mouths of rivers. Thus the first wave advancing meets in its course with resistance on the two sides of a narrow channel, it is forced to rise by the pressure of the following waves, whose motion is not at all retarded, or certainly less so than that of the first wave. Thus an actual current of water is produced in straits and narrow channels; and it is always important to distinguish between the tide wave, as bringing high water, and the tidal stream—between the rise and fall of the tide and the flow and ebb.

In the open ocean, and at a distance from the land, the tide wave is imperceptible, and the rise and fall of the water is small. Among the islands of the Pacific four to six feet is the usual spring rise. But the range is considerably affected by local causes, as by the shoaling of the water and the narrowing of the channel, or by the channel opening to the free entrance of the tide wave. In such cases the range of tide is 40 to 50 feet or more, and the tidal stream is one of great velocity. It may under such circumstances even present the peculiar phenomenon called the *bore*—a wave that comes rolling in with the first of flood, and, with a foaming crest, rushes onward, threatening destruction to shipping, and sweeping away all impediments lying in its course.

It is certain that in the open ocean the *great tide wave* could not be recognized as a wave, since it is merely a temporary alteration of the sea level.

Waves which have their origin in the action of the wind striking the surface of the water commence as a series of small and slow undulations or wavelets—a mere ripple. As the strength, and consequently the pressure, of the wind increases, waves are formed; and a numerical relation exists between the length of a wave, its velocity of progress, and the depth of the water in which it travels.

The *height* of a wave is measured from trough to crest; and though waves as seen from the deck of a small vessel appear to be "enormous" and "overwhelming," their height, in an ordinary gale, in deep water, does not exceed 15 to 20 feet. In a very heavy gale of some days' continuance they will, of course, be much higher.

Scoresby has observed them 30 ft. high in the North Atlantic; and Ross measured waves of 22 ft. in the South Atlantic. Wilkes records 32 ft. in the Pacific. But the highest waves have been reported off the Cape of Good Hope and Cape Horn, where they have been observed, on rare occasions, from 30 to 40 ft high; and 36 ft. has been given as the admeasurement in the Bay of Biscay, under very exceptional circumstances. In the voyage round the world the *Venus* and *Bonite* record a maximum of 27 ft., while the *Novara* found the maximum to be 35 ft. But waves of 12 to 14 ft. in shallow seas are often more trying than those of larger dimensions in deeper water. It is generally assumed that a distance from crest to crest of 150 to 350 ft. in the storm wave gives a velocity (in the change of form) of from 17 to 28 miles per hour. But what is required in the computation of the velocity is the period of passage between two crests. Thus a distance of 500 to 600 ft. between two crests, and a period of 10 to 11 seconds, indicates a velocity of 34 miles per hour.

The following table, by Sir G.B. Airy (late Astronomer Royal), shows the velocities with which waves of given lengths travel in water of certain depth:

	Length of the Wave in Feet.¹						
Depth of the Water in Feet.	10	100	1,000	10,000	100,000	1,000,000	10,000,000
	Corresponding Velocity of Wave per Hour in Nautical Miles.						
	1	3.2	3.4	3.4	3.4	3.4	3.4

10	4.3	10.1	10.7	10.8	10.8	10.8	10.8
100	4.3	13.5	32.0	34.0	34.0	34.0	34.0
1,000	4.3	13.5	42.9	101.8	107.5	107.5	107.5
10,000	4.3	13.5	42.9	135.7	320.3	340.0	340.3
100,000	4.3	13.5	42.9	135.7	429.3	1013.0	1075.3

From these numbers it appears that—

1. When the length of the wave is not greater than the depth of the water, the velocity of the wave depends (sensibly) only on its length, and is proportional to the square root of its length.
2. When the length of the wave is not less than a thousand times the depth of the water, the velocity of the wave depends (sensibly) only on the depth, and is proportional to the square root of the depth.

It is, in fact, the same as the velocity which a free body would acquire by falling from rest under the action of gravity through a height equal to half the depth of the water.

Rollers are of the nature of a violent *ground swell*, and possibly the worst of them may be due to the propagation of an earthquake wave. They come with little notice, and rarely last long. All the small islands in the Mid-Atlantic experience them, and they are frequent on the African coast in the calm season. They are also not unknown in the other oceans. In discussing the meteorology of the equatorial district of the Atlantic, extending from lat. 20° to 10° S, Captain Toynbee observes that "swells of the sea are not always caused by the prevailing wind of the neighborhood. For instance, during the northern winter and spring months, northwesterly swells abound. They are sometimes long and heavy, and extend to the most southern limit of the district. Again, during the southern winter and spring months, southerly and southwesterly swells abound, extending at times to the most northern limit of the district. They are frequently very heavy and long."

The great *forced sea waves*, due to earthquakes, and generally to subterranean and volcanic action, have been known to attain the enormous height of 60 feet or more, and sweep to destruction whole towns situated on the shores where they have broken—as for example Lisbon and places on the west coast of America and in the island of Java. Though so destructive when they come in toward the land, and begin to feel the shelving sea bottom, it is not probable that, in the open ocean, this wave would do more than appear as a long rolling swell. It has, however, been observed that "a wave with a gentle front has probably been produced by gentle rise or fall of a part of the sea bottom, while a wave with a steep front has probably been due to a somewhat sudden elevation or depression. Waves of complicated surface form again would indicate violent oscillations of the bottom."

The altitude and volume of the great sea wave resulting from an earthquake depend upon the suddenness and extent of the originating disturbance and upon the depth of water at its origin. Its velocity of translation at the surface of the sea varies with the depth of the sea at any given point, and its form and dimensions depend upon this also, as well as upon the sort of sea room it has to move in. In deep ocean water, one of these waves may be so long and low as to pass under a ship without being observed, but, as it approaches a sloping shore, its advancing slope becomes steeper, and when the depth of water becomes less than the altitude of the wave, it topples over, and comes ashore as an enormous and overwhelming breaker.

Lastly, there is the *storm wave*—the result of the cyclone or hurricane—and, perhaps, the greatest terror to seamen, for it almost always appears in the character of a *heavy cross sea*, the period of which is irregular and uncertain. The disturbance within the area of the cyclone is not confined to the air, but extends also to the ocean, producing first a rolling swell, which eventually culminates in a tremendous pyramidal sea and a series of storm waves, the undulations of which are propagated to an extraordinary distance, behind, before, and on each side of the storm field.

Enough has now been said to show that whatever the character of the waves encountered by the *Umbria* and *Martello* in July last, they were in no sense "tidal," but, if approximating to the dimensions stated, they were either due to storm or earthquake, or, possibly, to a combination of both the last agents.

For those of our readers who may be interested in wave observations, we conclude by introducing Prof. Stokes' summary of the method of observing the phenomenon:

"For a Ship at Sea.

"(1.) The apparent periodic time,² observed as if the ship were at rest.

"(2.) The *true* direction from which the waves come, also the ship's

true course and speed per hour.

"(3.) A measure or estimate of the height of the waves.

"(4.) The depth of the sea if it is known, but, at any rate, the position of the ship as near as possible, either by cross bearings of land or any other method, so that the depth may be got from charts or other sources.

"For a Ship at Anchor.

"(1.) The periodic time.

"(2.) The true direction from which the waves come.

"(3.) A measure or estimate of the height of the waves.

"(4.) The depth of water where she is anchored."

It is the opinion of scientists that when the period of oscillation of the ship and the period of the wave are nearly the same, the turning over of the ship is an approximate consequence, and thus the wave to such a ship would appear more formidable than to another ship with a different period of oscillation.—*Nautical Magazine.*

[1]

As an example, this table shows that waves 1,000 feet in length travel 43 nautical miles per hour in water 1,000 feet deep. The length is measured from crest to crest.

[2]

The period of a wave is the interval of time which elapses between the transits of two successive wave crests past a stationary floating body, the wave crest being the highest line along the ridge.

PRACTICAL EDUCATION.

It is now recognized that one of the elements in which the public school systems of the United States are most lacking is in the practical branches in teaching trades and industry. There is too much book learning, too little practical education. Throughout the continent of Europe there are trade and industrial schools which have accomplished much in turning out skilled workmen for the various branches of industry. Here we have one. Our deficiency in this matter was recognized by the late commissioner of education, and attention called to it in several of his reports, and a number of the State superintendents of education have also urged the establishment of manual or training schools as a part of the State systems. We have such an institution here in the Tulane Manual School. In Philadelphia, Cleveland, and Chicago, the system has been adopted on a large scale, and made part of the high school course. Another city which has inaugurated the manual training school as a part of its public schools is Toledo, O. A rich citizen of that town, who recently died, left a large sum for the establishment of a university of arts and trades. Instead of founding a separate university, however, the money was applied to the establishment of manual schools in connection with the public schools, for both boys and girls.

The course of girls' work given will afford some idea of what it is proposed to do. This begins with the senior grammar school grade and continues three years in high school. It includes free hand, mechanical, and architectural drawing, light carpentry, wood carving, designing for wood carving, wood turning, clay moulding, decorative designing, etc. But more practical than these things are the lessons in cooking, sewing, and household management. The course in domestic economy "is arranged with special reference to giving young women such a liberal and practical education as will inspire them with a belief in the dignity and nobleness of an earnest womanhood, and incite them to a faithful performance of the every day duties of life. It is based upon the assumption that a pleasant home is an essential element of broad culture, and one of the surest safeguards of morality and virtue." The report of the school also remarks that "the design of this course is to furnish thorough instruction in applied housekeeping, and the sciences related thereto, and students will receive practical drill in all branches of housework; in the purchase and care of family supplies, and in general household management; but will not be expected to perform more labor than is actually necessary for the desired instruction."

A special branch which will be well received is that which proposes to teach the girls how to cook. The curriculum is one that every housekeeper ought to go through.

Boiling—Practical illustrations of boiling and steaming, and treatment of vegetables, meats, fish, and cereals, soup making, etc.

Broiling—Lessons and practice in meat, chicken, fish, oysters, etc.

Bread Making—Chemical and mechanical action of materials used. Manipulations in bread making in its various departments. Yeasts and their substitutes.

Baking—Heat in its action on different materials in the process of baking. Practical experiments in baking bread, pastry, puddings, cakes, meat, fish, etc.

Frying—Chemical and mechanical principles involved and illustrated in the frying of vegetables, meats, fish, oysters, etc.

Mixing—The art of making combinations, as in soups, salads, puddings, pies, cakes, sauces, dressings, flavorings, condiments, etc.

In "marketing, economy," etc., the course comprises general teaching on the following subjects:

"The selection and purchase of household supplies. General instructions in systematizing and economizing the household work and expenses. The anatomy of animals used as food, and how to choose the several parts. Lessons on the qualities of water and steam; the construction of stoves and ranges; the properties of different fuels."

Again, there is a dressmaking and millinery department, where the girls are taught how to cut and make dresses and other garments, and the economical and tasteful use of materials.

So much for the girls. The courses in the boys' schools are somewhat similar, turning, however, on the more practical instruction in trades and industries, in carpentering, wood and iron work, etc.

The Toledo experiment has been tried there but one year, and has given general satisfaction. The board of school directors has interested the public in its efforts, and advisory committees of ladies and gentlemen have been appointed to assist in managing these schools.

It is to be hoped that other and larger cities will imitate Toledo in the matter. Those philanthropists who are giving money so liberally for the establishment of institutions of higher learning might do much good in providing for manual training schools of this kind that will assure the country good housewives and skilled mechanics in the future.—*Trustees' T. Jour.*

A GIGANTIC LOAD OF LUMBER.

When it was announced in the *Lumberman* that the barge Wahnapiæ had carried a cargo of 2,181,000 feet of lumber, letters were received asking if it was not a typographical error. It was thought by many that no boat could carry such a load. For the purpose of showing the barge on paper, a photograph was obtained of her when loaded at Duluth, which is herewith reproduced. The freight rate obtained to Tonawanda was \$3.75 a thousand, which footed up to a total of \$8,178.75 The owners of the boat, however, were not satisfied with such a record, and proceeded to break it by loading at Duluth 2,409,800 feet of lumber, which also went to Tonawanda, and which is put down as the biggest cargo of lumber on record. At the latter place the cargo was unloaded on Saturday afternoon and Monday forenoon—one working day. It will be readily understood that the money-making capacity of the barge is of the Jumbo order also.

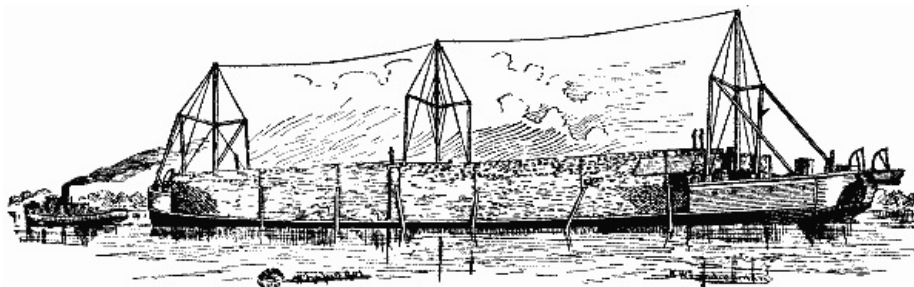

THE BARGE WAHNAPITÆ, LOADED WITH 2,181,000 FEET OF LUMBER.

The barge is owned by the Saginaw Lumber and Salt Company and the Emery Lumber Company, and cost \$30,000. She is 275 feet long and 51 feet beam. The lumber on her was piled 22 feet high and she drew 11 feet of water. Had she been 10

inches wider, she could not have passed through the Soo canal. The boat was built on the Saginaw river a year ago last winter, and was designed for carrying logs from the Georgian bay to the Saginaw river and Tawas mills. The Canadian government, however, increased the export duty on logs, and the barge was put into the lumber-carrying trade—*N.W. Lumberman*.

THE NEWBERY-VAUTIN CHLORINATION PROCESS.

The process of extracting gold from ores by absorption of the precious metal in chlorine gas, from which it is reduced to a metallic state, is not a very new discovery. It was first introduced by Plattner many years ago, and at that time promised to revolutionize the processes for gold extraction. By degrees it was found that only a very clever chemist could work this process with practically perfect results, for many reasons. Lime and magnesia might be contained in the quartz, and would be attacked by the chlorine. These consume the reagents without producing any results, earthy particles would settle and surround the small gold and prevent chlorination, then lead and zinc or other metals in combination with the gold would also be absorbed by the chlorine; or, again, from some locally chemical peculiarity in the water or the ore, gold held in solution by the water might be again precipitated in the tailings before filtration was complete, and thus be lost. Henderson, Clark, De Lacy, Mears, and Deacon, all introduced improvements, or what were claimed to be improvements, on Plattner, but these chiefly failed because they did not cover every particular variety of case which gold extraction presented. Therefore, where delicate chemical operations were necessary for success, practice generally failed from want of knowledge on the part of the operator, and many times extensive plants have been pronounced useless from this cause alone. Hence it is not to be wondered that processes requiring such care and uncommon knowledge are not greatly in favor.

Mr. Claude Vautin, a gentleman possessed of much practical experience of gold mining and extraction in Queensland, together with Mr. J. Cosmo Newbery, analytical chemist to the government of Victoria, have developed a process which they claim to combine all the advantages of the foregoing methods, and by the addition of certain improvements in the machinery and mode of treatment to overcome the difficulties which have hitherto prevented the general adoption of the chlorination process.

By reference to the illustrations of the plant below, the system by which the ore is treated can be readily understood. The materials for treatment—crushed and roasted ore, or tailings, as the case may be—are put into the hopper above the revolving barrel, or chlorinator. This latter is made of iron, lined with wood and lead, and sufficiently strong to bear a pressure of 100 lb. to the square inch, its capacity being about 30 cwt of ore. The charge falls from the hopper into the chlorinator. Water and chlorine-producing chemicals are added—generally sulphuric acid and chloride of lime—the manhole cover is replaced and screwed down so as to be gas tight. On the opposite side of the barrel there is a valve connected with an air pump, through which air to about the pressure of four atmospheres is pumped in, to liquefy the chlorine gas that is generated, after which the valve is screwed down. The barrel is then set revolving at about ten revolutions a minute, the power being transmitted by a friction wheel. According to the nature of the ore, or the size of the grains of gold, this movement is continued from one to four hours, during which time the gold, from combination with the chlorine gas, has formed a soluble gold chloride, which has all been taken up by the water in the barrel. The chlorinator is then stopped, and the gas and compressed air allowed to escape from the valve through a rubber hose into a vat of lime water. This is to prevent the inhalation of any chlorine gas by the workmen. The manhole cover is now removed and the barrel again set revolving, by which means the contents are thrown automatically into the filter below. This filter is an iron vat lined with lead. It has a false bottom, to which is connected a pipe from a vacuum pump working intermittently. As soon as all the ore has fallen from the chlorinator into the filter, the pump is set going, a partial vacuum is produced in the chamber below the false bottom in the filter, and very rapid filtration results. By this means all the gold chlorides contained in the wet ore may be washed out, a continual stream being passed through it while filtration is going on. The solution running from the filter is continually tested, and when found free from gold, the stream of water is stopped, as is also the vacuum pump. The filter is then tipped up into a truck below, and the tailings run out to the waste heap. The process of washing and filtration occupies about an hour, during which time another charge may be in process of treatment in the chlorinator above. The discharge from the filter and the washings are run into a vat, and from this they are allowed to pass slowly through a tap into a charcoal filter. During the passage of the liquid through the charcoal filter, the chloride of gold is decomposed and the gold is deposited on the charcoal, which, when fully charged, is burnt, the ashes are fused with borax in a crucible, and the gold is obtained.

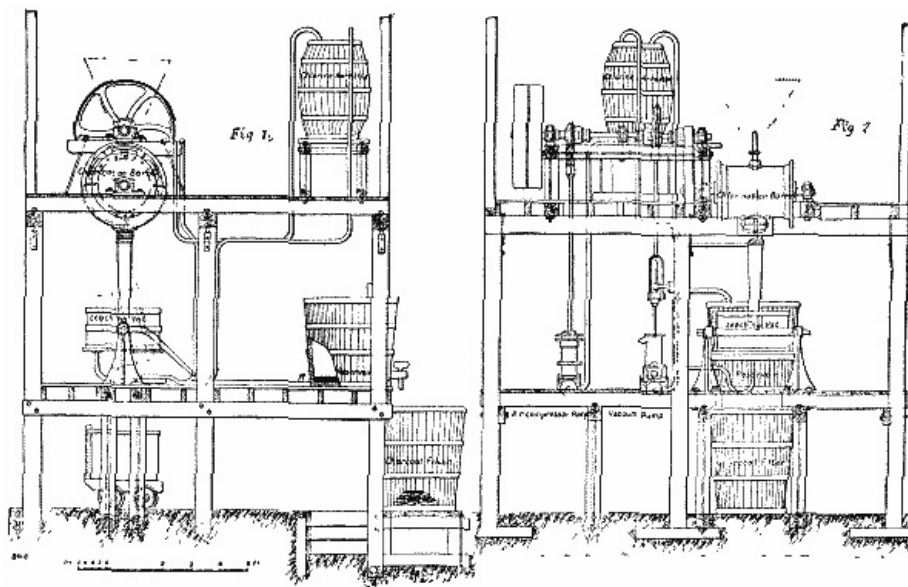

THE NEWBERY-VAUTIN CHLORINATION PROCESS.

We have specified above the objections to the old processes of chlorination, so it may be fairly asked in what way the Newbery-Vautin process avoids the various chemical actions which have hitherto proved so difficult to contend with.

For any system of chlorination yet introduced it is necessary to free the ore from sulphides. This is done by roasting according to any of the well-known systems in vogue. It is a matter which requires great care and considerable skill. The heat must be applied and increased slowly and steadily. If, through any neglect on the part of the roaster, the ore is allowed to fuse, in most cases it is best to throw the charge away, as waste. This roasting applies equally to the Vautin process as to any others. So on this head there is no alteration. One of the most important advantages is not a chemical one, but is the rapidity with which the charge can be treated. In the older styles of treatment the time varied from thirty six to ninety hours. Now this is accomplished in from three to six hours with a practically perfect result. The older processes required a careful damping of the ore, which, to get good results, must leave the ore neither too wet nor too dry. Now "damping" is entirely done away with, and in its place water is poured into the barrel. Pressure to the extent of four atmospheres causes chlorine gas to leave its vaporous form. Thus the pressure applied not only enables a strong solution of chlorine to be formed with the water in the barrel, but forces this into contact with the gold through every crevice in the ore. Chlorine gas also takes up any silver which may exist in association with the gold. In the older processes this is deposited as a film of chloride of silver around the fine gold grains, and from its insolubility in water prevents the absorption of the gold. The rotary motion of the barrel in the Newbery-Vautin method counteracts this by continually rubbing the particles together; this frees the particles from any accumulations, so that they always present fresh surfaces for the action of the solvent. Again, the short time the ore is in contact with the chlorine does not allow of the formation of hydrochloric acid, which has a tendency to precipitate the gold from its soluble form in the water before being withdrawn from the chlorinator.

Hitherto, when the ore was very fine or contained slimes, the difficulty of filtration was increased, sometimes in extreme cases to such an extent that chlorination became impracticable. By the introduction of the vacuum pump this is greatly facilitated; then by making the action intermittent a jiggling motion is given to the material in the filter which prevents any clogging except in cases of extreme fineness.

The advantage of using charcoal as a decomposing agent for chloride of gold was pointed out by Mr. Newbery some twenty years ago; four or five years since the idea was patented in the United States, but as this was given gratis to the world years before, the patent did not hold good. The form of precipitation generally adopted was to add sulphate of iron to the liquid drawn from the filter. This not only threw down the gold it contained, but also the lime and magnesia. Then very great care was necessary, and a tedious process had to be gone through to divide the gold from these. Now, by filtration through charcoal everything that is soluble in hydrochloric acid passes away with the water; for instance, lime and magnesia, which before gave such great trouble. In passing through the charcoal, the chloride of gold is decomposed and all fine gold particles are taken up by the charcoal, so that it is coated by what appears to be a purple film.

Should copper be associated with the gold, the water, after running through the charcoal filter, is passed over scrap iron, upon which the copper is precipitated by a natural chemical action. If silver is contained in the ore, it is found among the

tailings in the filter, in a chloride which is insoluble in water. Should the quantity prove sufficiently large, it may be leached out in the usual way by hyposulphites.

One of the great advantages common to all systems of chlorination is that ores may be crushed dry and treated, so that the loss from float gold may be avoided. Of this loss, which is most serious, we shall have something to say on another occasion. An advantage in amalgamation with chlorine gas instead of amalgamation with quicksilver in the wet way, is that the ore need not be crushed so finely. Roasting takes the place of fine crushing, as the ore from the roasting furnace is either found somewhat spongy in texture or the grains of silica in which fine gold may be incased are split or flawed by the fire. For quicksilver amalgamation very fine crushing is necessary to bring all gold particles in contact with it. Quicksilver being so thick in substance, it will not find its way readily in and out of a microscopically fine spongy body or through very fine flaws in grains of silica, whereas chlorine gas or a solution of liquefied chlorine does this, and absorbs the gold far more readily.

There are cases when gold is contained in ores in what is known as a perfectly "free" form—that is, there is an absence of all sulphides, arsenides, etc.—when it is not practicable to extract it either with the ordinary forms of quicksilver amalgamation or of any process of chlorination, without first roasting. This is because the finer gold is locked up inside fine grains of silica and hydrated oxide of iron. No ordinary crushing will bring this fine enough, but when roasting is resorted to by drawing it rapidly through a furnace heated to a cherry red, these grains are split up so that chlorine gas is enabled to penetrate to the gold.

It may be said that an equally clever chemist will be required to work this improved process as compared with those that have, one by one, fallen into disuse, mainly from want of knowledge among the operators. To a certain extent this is so. The natural chemical actions are not so delicate, but an ignorant operator would spoil this process, as he does nearly every other. When a reef is discovered, practice shows that its strongest characteristics are consistently carried throughout it wherever it bears gold. Before Messrs. Newbery and Vautin leave a purchaser to deal himself with their process, they get large samples of his ore to their works and there experiment continually until a practically perfect result is obtained; then any one with a moderate amount of knowledge can work with the formula supplied. It has been their experience that the ore from any two mines rarely presents the same characteristics. Experiments are begun by treating very coarse crushings. These, if not satisfactory, are gradually reduced until the desired result is obtained.

To treat the whole body of ore from a mine, dry crushing is strongly recommended. To accomplish this in the most efficient manner, a stone breaker which will reduce to about $\frac{1}{4}$ in. cubes is necessary. For subsequent crushing Kroms rolls have, up to the present time, proved most satisfactory. They will crush with considerable evenness to a thirty mesh, which is generally sufficient. The crushings are then roasted in the ordinary way in a reverberatory furnace and the whole of the roastings are passed through the machine we have just described. By this it is claimed that over 90 per cent. of the gold can be extracted at very much the same cost as the processes now in general use in gold producing countries, which on the average barely return 50 per cent. If so, the gentlemen who have brought forward these improvements deserve all the success their process promises.—*Engineering*.

APPARATUS FOR EXERCISING THE MUSCLES.

The apparatus herewith illustrated consists of a wooden base, which may be bolted to the floor, and which supports two wooden uprights, to which is affixed the apparatus designed to exercise the legs. The apparatus for exercising the arms is mounted upon a second frame that slides up and down the wooden supports. It is fixed in position at any height by means of two screws.

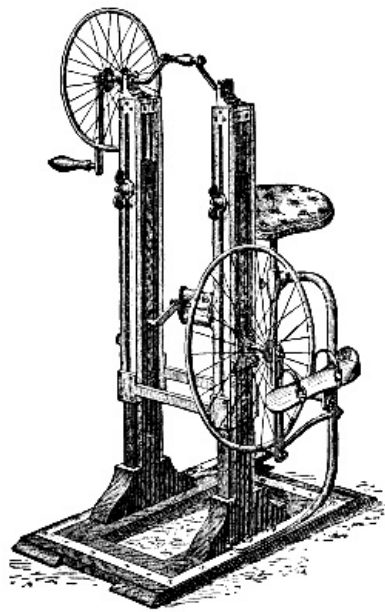

APPARATUS FOR EXERCISING THE MUSCLES.

The apparatus for exercising the legs, as well as the one for the arms, consists essentially of a fly wheel mounted upon an axle extending to the second upright and bent into the form of a crank in the center. The fly wheel is provided with a winch whose arm is capable of elongation in order to accommodate it to the reach of the sound limb.

The apparatus for the legs is arranged in a contrary direction, that is to say, the wheel is on the opposite side of the frame, and upon the fixed uprights. It is really a velocipede, one of the pedals of which is movable upon the winch, and is capable of running from the axle to the extremity, as in the upper apparatus. This pedal has the form of a shoe, and is provided with two straps to keep the foot in place and cause it to follow the pedal in its rotary motion. A movable seat, capable of rising and descending and moving backward and forward, according to the leg that needs treatment, is fixed back of the apparatus.

The operation is as follows: Suppose that the atrophied arm is the left one. The invalid, facing the apparatus, grasps the movable handle on the crank with his left hand, and revolves the winch with his right. The left hand being thus carried along, the arm is submitted to a motion that obliges it to elongate and contract alternately, and the result is an extension of the muscles which strengthens them.

The apparatus, which is as simple as it is ingenious, can, it is true, be applied only when one of the two limbs, arm or leg, is diseased, the other being always necessary to set the apparatus in motion; but, even reduced to such conditions, it is destined to render numerous services in cases of paralysis, atrophy, contusions, etc.—*Moniteur des Inventions Industrielles*.

THE BULL OPTOMETER.

Dr. Javal has just presented to the Academy of Medicine a very ingenious and practical optometer devised by George J. Bull, a young American doctor, after a number of researches made at the laboratory of ophthalmology at the Sorbonne. Among other applications that can be made of it, there is one that is quite original and that will insure it some success in the world. It permits, in fact, of approximately deducing the age of a person from certain data that it furnishes as to his or her sight. As well known, the organs become weak with age, their functions are accomplished with less regularity and precision, and, according to the expression of the poet,

"En marchant a la mort, on meurt a chaque pas,"

the senses become blunted, the hearing becomes dull, the eyes lose their luster, vivacity, and strength, and vision becomes in general shorter, less piercing, and less powerful.

The various parts of the eye, but more particularly the crystalline lens, undergo modifications in form and structure. Accommodation is effected with more and more difficulty, and, toward the age of sixty, it can hardly be effected at all.

These changes occur in emmetropics as well as in hypermetropics and myopics.

As will be seen, then, there is a relation between the age of a person and the

amplitude of the accommodation of his eyes. If we cannot express a law, we can at least, through statistics, find out, approximately, the age of a person if we know the extent of the accommodation of his eyes.

A Dutch oculist, Donders, has got up a table in which, opposite the amplitudes, the corresponding ages are found. Now, the Javal-Bull optometer permits of a quick determination of the value of the amplitude of accommodation in *dioptries*. (A dioptrie is the power of a lens whose focal distance is one meter.)

The first idea of this apparatus is due to the illustrious physicist Thomas Young, who flourished about a century ago. The Young apparatus is now a scarcely known scientific curiosity that Messrs. Javal and Bull have resuscitated and transformed and completed.

It consists of a light wooden rule about 24 inches long by 1¼ inch wide that can easily be held in the hand by means of a handle fixed at right angles with the flat part (Fig. 1). At one extremity there is a square thin piece of metal of the width of the rule, and at right angles with the latter, but on the side opposite the handle. This piece of metal contains a circular aperture a few hundredths of an inch in diameter (Fig. 3). Toward this aperture there may be moved either a converging lens of five dioptries or a diverging lens of the same diameter, but of six dioptries.

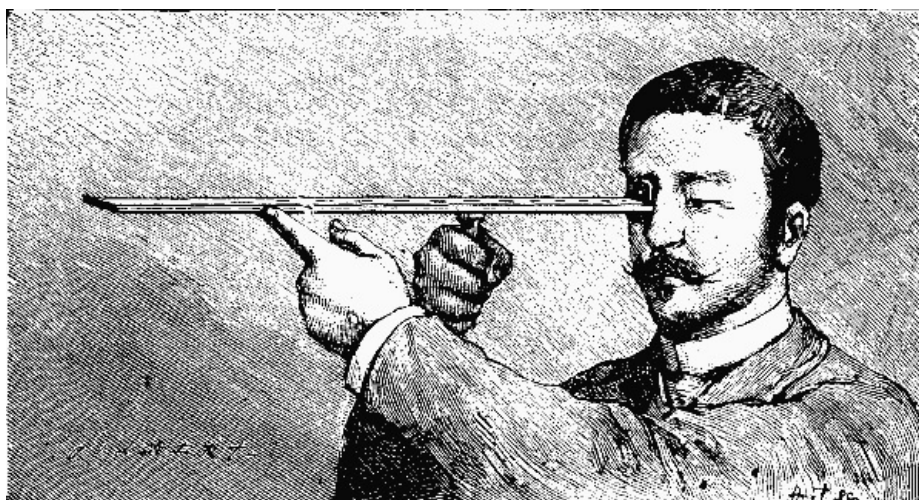

FIG 1.—MODE OF USING THE BULL OPTOMETER

On holding the apparatus by the handle and putting the eye to the aperture, provided or not with a lens, we see a series of dominoes extending along the rule, from the double ace, which occupies the extremity most distant from the eye, to the double six, which is very near the eye (Fig. 2). The numbers from two to twelve, simply, are indicated, but this original means of representing them has been chosen in order to call attention to them better.



FIG 2.—THE RULE, WITH THE DOMINOES (¼ Actual Size.)

Figures are characters without physiognomy, if we may so express ourselves, while the spots on the dominoes take particular arrangements according to the number represented, and differentiate themselves more clearly from each other than figures do. They are at the same time more easily read than figures or regularly spaced dots. Now, it is very important to fix the attention upon the numbers, since they are arranged at distances expressed in dioptries and indicated by the number of the spots. On looking through the aperture, we see in the first place one of the dominoes more distinctly than the rest. Then, on endeavoring to see those that are nearer or farther off, we succeed in accommodating the eye and in seeing the numbers that express the extreme terms of the accommodation, and consequently the amplitude.

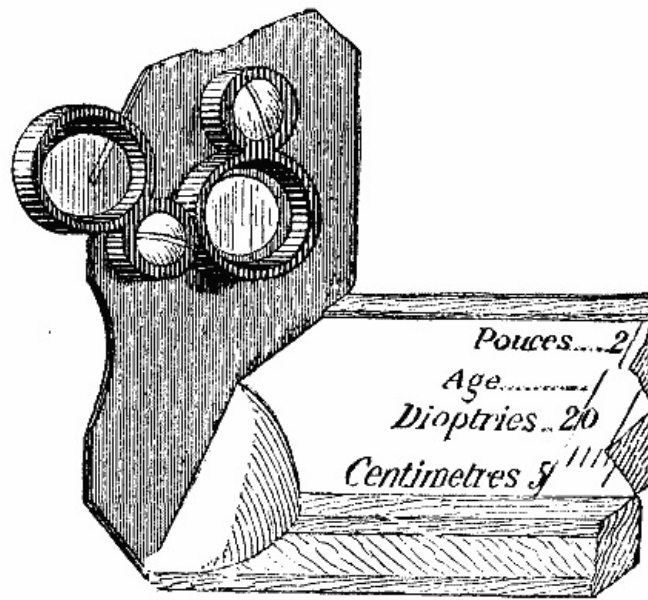

FIG. 3.—DETAILS OF EYE PIECE.

Let us now take some examples: If we wish to express in dioptries the myopia of a person, we put the apparatus in his hand, and ask him to place his eye very near the aperture and note the number of spots on the most distant domino that he sees distinctly. This is the number sought. If the observation be made through the upper lens, it will be necessary to subtract five from the number obtained; if, on the contrary, the other lens is used, it will be necessary to add six.

If it is a question of a presbyope, let him look with his spectacles, and note the nearest domino seen distinctly. This will be the number of dioptries expressing the nearest point at which he can read. This number permits us to know whether it is necessary to add or subtract dioptries in order to allow him to read nearer by or farther off. If, for example, he sees the deuce and the ace distinctly, say 3 dioptries or 0.33 meter, and we want to allow him to read at 0.25 meter, corresponding to four dioptries, it will be necessary to increase the power of his spectacles by one dioptrie.

Upon the whole, Dr. Bull's optometer permits of measuring the amplitude of accommodation, and, consequently, of obtaining the approximate age of people, of knowing the extreme distances of the accommodation, and of quickly finding the number of the glass necessary for each one. It reveals the defects in the accommodation, and serves for the quick determination of refraction. So, in saying that this little instrument is very ingenious and very practical, Dr. Javal has used no exaggeration.—*La Nature*.

THE SANITATION OF TOWNS.¹

By Mr. J. GORDON, C.E.

The average mortality for England and Wales was 22.4 in 1838, and in 1886 19.3, which shows a saving on last year's population of England and Wales of 86,400 lives annually, and a saving in suffering from an estimated number of about 1,728,000 cases of sickness. To accomplish all this, vast sums of money have been expended, probably not always wisely, inasmuch as there have been mistakes made in this direction, as in all new developments of science when applied in practice, and evils have arisen which, if foreseen at all at the outset, were underrated.

The great object of the public health act, 1848, was to enable local authorities by its adoption to properly sewer, drain, and cleanse their towns, and to provide efficient supplies of water, free from contamination and impurities dangerous to health. The raising of money by loans repayable in a series of years, which the act empowered, enabled all these objects to be accomplished, and, while the first duty of local authorities was undoubtedly the provision of a good supply of water and proper sewerage for the removal of liquid filth from the immediate vicinity of inhabited dwellings, the carrying out of proper works for the latter object has been of much slower growth than the former. Private companies led the way, in fact, in providing supplies of water, inasmuch as there was a prospect of the works becoming remunerative to shareholders investing their money in them; and in nearly every instance where local authorities have eventually found it to be in the interests of the inhabitants of their districts to purchase the work, they have had to pay high prices for the undertaking. This has generally led to a great deal of dissatisfaction with companies holding such works, but it must not be forgotten that the companies

would, in most instances, never have had any existence if the local authorities had taken the initiative, and that but for the companies this great boon of a pure supply of water would most probably have been long delayed to many large as well as small communities.

The evils which have arisen from the sewerage and draining of towns have been of a twofold character. First, in the increased pollution of rivers and streams into which the sewage, in the earlier stages of these works, was poured without any previous treatment; and secondly, in the production of sewer gas, which up to the present moment seems so difficult to deal with. These concomitant evils and difficulties attending the execution of sanitary works are in no way to be underrated, but it still remains the first duty of town authorities to remove, as quickly as possible, all liquid and other refuse from the midst and immediate vicinity of large populations, before putrefaction has had time to take place.

There are some minds whose course of reasoning seems to lead them to the conclusion that the evils attending the introduction of modern systems of sewerage are greater than those of the old methods of dealing with town sewage and refuse, but the facts are against them to such an extent that it would be difficult to point to a responsible medical officer in the kingdom who would be courageous enough to advocate a return to the old regime of cesspools, privy ashpits, open ditches, and flat bottomed culverts. The introduction of earth closets as one of the safeguards against sewer gas has made no headway for large populations, and is beset with practical difficulties.

In the Midland and Lancashire towns the system known as the pail or tub system has been much more largely introduced as a substitute for the water closet, and it has, from a landlord's point of view, many attractions. In the first place, the first cost, as compared with that of a water closet, is very small, and the landlord is relieved for ever afterward I believe, in most towns, of all future costs and maintenance; whereas, in the case of water closets, there is undoubtedly great difficulty in cottage property in keeping them in good working order, especially during the frosts of winter. There are, however, many objections to the pail system, which it is not proposed to touch upon in this address, beyond this, that it appears to be a costly appendage to the water carriage system, without the expected corresponding advantage of relieving the municipal authorities of any of the difficulties of river pollution, inasmuch as the remaining liquid refuse of the town has still to be dealt with by the modern systems of precipitation or irrigation, at practically the same cost as would have been the case if the water carriage system had been adopted in its entirety.

The rivers pollution act gave an impetus to works for the treatment of sewage, although much had been done prior to that, and Leicester was one of those towns which led the way so early as 1854 in precipitating the solids of the sewage before allowing it to enter the river. The innumerable methods which have since then been tried, and after large expenditures of money have proved to be failures, show the difficulties of the question.

On the whole, however, sewage farms, or a combination of the chemical system with irrigation or intermittent filtration, have been the most successful, so that the first evil to which the cleansing of towns by the increased pollution of rivers gave rise may now be said to be capable of satisfactory solution, notwithstanding that the old battle of the systems of precipitation versus application of sewage to land still wages whenever opportunity occurs.

The second evil to which I have made reference, viz., that of sewer ventilation, seems still unsolved, and I would earnestly entreat members, all of whom have more or less opportunities of experimenting and making observations of the behavior of sewer gas under certain conditions, to direct their attention to this subject. It is admitted on all hands that the sewers must be ventilated—that is, that there must be a means of escape for the polluted air of the sewers; for it is well known that the conditions prevailing within the sewers during the twenty-four hours of the day are very varying, and on this subject the early observations of the late medical officer for the City of London (Dr. Letheby), and the present engineer for the City of London (Lieutenant-Colonel Heywood), and the still more recent investigations of Professor Pettenkofer, of Munich, Professor Soyka, of Prague, and our own members, Mr. McKie, of Carlisle, Mr. Read, of Gloucester, and others, are worthy of attention. It does not, however, seem to be so readily or universally conceded that a plentiful supply of fresh air is of equal importance, and that the great aim and object of sewer ventilation should be the introduction of atmospheric air for the purpose of diluting and oxidizing the air of the sewers, and the creation of a current to some exit, which shall, if possible, either be above the roofs of the houses, or, still better, to some point where the sewer gas can be cremated. The most recent contribution to this subject, in direct opposition to these views, is to be found in the address of Professor Atfield to the Hertfordshire Natural History Society and Field Club, in which it is laid down that all that is necessary is a vent at an elevation above the ground, and

that, therefore, the surface ventilators, or other openings for the introduction of fresh air, are not only not necessary, but are, on the contrary, injurious, even when acting as downcast shafts.

These aims and objects are beset with difficulties, and the most scientific minds of the country have failed so far to devise a method of ventilation which shall at the same time be within the range of practical application as regards cost and universally satisfactory.

The report of last year of a committee of the metropolitan board of works is worth attention, as showing the opinion of metropolitan surveyors. Out of forty districts, the opinions of whose surveyors were taken, thirty-five were in favor of open ventilation, two were doubtful, two against, and one had no experience in this matter. The average distances of the ventilators were from 30 to 200 yards, and the committee came to the conclusion that "pipe ventilators of large section can be used with great advantage in addition to, and not in substitution for, surface ventilators." To supplement the street openings as much as possible with vertical cast iron or other shafts up the house sides would seem to be the first thing to do, for there can be no doubt that the more this is done, the more perfect will be the ventilation of the sewers. It must also not be forgotten that the anxiety, of late years, of English sanitarians to protect each house from the possible dangers of sewer gas from the street sewer has led to a system of so-called disconnection of the house drains by a water seal or siphon trap, and that, consequently, the soil pipes of the houses, which, when carried through the roofs, acted as ventilators to the public sewers, have been lost for this purpose, and thus the difficulty of sewer ventilation has been greatly increased.

In Leicester we have been fortunate enough to secure the co-operation of factory owners, who have allowed us to connect no fewer than fifty-two chimneys; while we have already carried out, at a cost of about £1,250, 146 special shafts up the house sides, with a locked opening upon a large number of them, by means of which we can test the velocity of the current as well as the temperature of the outflowing air. The connections with the high factory chimneys are all of too small a caliber to be of great use, being generally only six inches, with a few exceptionally of nine inches in diameter.

The radius of effect of specially erected chimneys, as shown by the experiments of Sir Joseph Bazalgette, and as experienced with the special ventilating towers erected at Frankfurt, is disappointing and discouraging when the cost is taken into consideration. It can not be expected, however, that manufacturers will admit larger connections to be made with their chimney; otherwise, of course, much more satisfactory results would be obtained. To fall back upon special shafts up the house sides means, in my opinion, that there should be probably as many in number as are represented by the soil pipes of the houses, for in this we have a tested example at Frankfurt, which, so far as I know, has up to the present moment proved eminently satisfactory.

The distance apart of such shafts would largely depend on the size of them, but as a rule it will be found that house owners object to large pipes, in which case the number must be increased, and if we take a distance of about 30 yards, we should require about 5,000 such shafts in Leicester. Whether some artificial means of inducing currents in sewers by drawing down fresh air from shafts above the eaves of the houses, and sending forth the diluted sewer gas to still higher levels, or burning it in an outcast shaft, will take the place of natural ventilation, and prove to be less costly and more certain in its action, remains to be seen. But it is quite certain that notwithstanding the patents which have already been taken out and failed, and those now before the public, there is still a wide field of research before this question is satisfactorily solved, so that no cause whatever shall remain of complaint on the part of the most fastidious.

One other important question common to all towns is that of the collection and disposal of the ashes and refuse of the households. It is one which is becoming daily more difficult to deal with, especially in those large communities where the old privy and ashpit system has not been entirely abolished. The removal of such ashes is at all times a source of nuisance, and if they cannot be disposed of to the agriculturists of the district, they become a source of difficulty. In purely water-closeted towns the so-called dry ashpits cannot be kept in such a condition as to be entirely free from nuisance, especially in the summer months, inasmuch as the refuse of vegetable and animal matter finds its way into them, and they are, in close and inhabited districts, necessarily too close to the living apartments of the dwellings. The tendency therefore now is rather to discourage the establishment of ashpits by the substitution of ashbins, to be collected daily or weekly as the case may be, and I think there can be no doubt that from a sanitary point of view this is by far the best system, harmonizing as it does with the general principle applicable to town sanitation of removing all refuse, likely by decomposition to become dangerous to health, as quickly as possible from the precincts of human habitations.

The difficulty of disposing of the ashes, mixed as they must necessarily be with animal and vegetable matter, is one that is forcing itself upon the attention of all town authorities, and the days of the rich dust contractors of the metropolis are practically numbered. Destruction by fire seems to be the ultimate end to be aimed at, and in this respect several towns have led the way. But as this is a subject which will be fully dealt with by a paper to be read during the meeting, I will not anticipate the information which will be brought before you, further than to say that the great end to be aimed at in this method of disposing of the ashes and refuse of towns is greater economy in cost of construction of destructors, as well as in cost of working them.

The progress in sanitation on the Continent, America, and the colonies has not been coincident with the progress in England, but these countries have largely benefited by the experience of the United Kingdom, and in some respects their specialists take more extreme views than those of this country in matters of detail. This is, perhaps, more particularly the case with the Americans, who have devised all sorts of exceptional details in connection with private drainage, in order to protect the interior of the houses from sewer gas, and to perfect its ventilation. In plumbing matters they seem also to be very advanced, and to have established examinations for plumbers and far-reaching regulations for house drainage.

Time will not permit me to examine into the works of a sanitary character which have been undertaken in the several countries after the example of England, but they have been attended with similar beneficial results and saving in life and sickness as in this country, although the Continental towns which have led the way with such works cannot as yet point to the low rates of mortality for large towns which have been attained in England, with the exception of the German towns of Carlsruhe, Frankfurt, Wiesbaden, and Stuttgart, which show death rates of 20.55, 20.64, 22, and 21.4 respectively. The greatest reduction of the mortality by the execution of proper sewerage and water works took place in Danzig, on the Baltic, and Linz, on the Danube, where after the execution of the works the mortality was reduced by 7.85 and 10.17 per 1,000 respectively, and in the case of Danzig this reduction is almost exclusively in zymotic diseases. Berlin is also a remarkable example of the enterprise of German sanitarians, for there they are demonstrating to the world the practicability of dealing with the sewage from a population of over 1¼ million upon 16,000 acres of land, of which about 10,000 acres are already under irrigation.

In taking this chair, it has been usual, when meetings have been held out of London, for your president to give some account of the works of his own town. In the present instance I feel that I can dispense with this course, in so far as that I need not do more than generally indicate what has been the course of events since I read to a largely attended district meeting in May, 1884, a paper on "The Public Works of Leicester." At that time large flood prevention works were in course of construction, under an act obtained in 1881, for continuing the river improvement works executed under previous acts. The works then under contract extended from the North Mill Lock and the North Bridge on the north to the West Bridge and Bramstone Gate Bridge on the south, along the river and canal, and included bridges, weirs, retaining walls, and some heavy underpinning works in connection with the widening and deepening of the river and canal. These works were duly completed, as well as a further length of works on the River Soar up to what is known as the old grass weir, including the Braunstone Gate Bridge, added to one of the then running contracts, at a total cost, excluding land and compensation, of £77,000. At this point a halt was made in consequence of the incompleteness of the negotiations with the land owners on the upper reach of the river, and this, together with various other circumstances, has contributed to greater delay in again resuming the works. In the interval, a question of whether there should be only one channel for both river and canal instead of two, as authorized by the act, has necessarily added considerably to the delay. But as that has now been settled in favor of the original parliamentary scheme, the authority of the council has been given to proceed with the whole of the works.

One contract, now in progress, which members will have an opportunity of inspecting, was let to Mr. Evans, of Birmingham, in March last, for about £18,000. It consists of a stone and concrete weir, 500 feet in length, with a lock of 7 feet 6 inches lift and large flood basins, retaining and towing path walls, including a sunk weir parallel with the Midland Railway viaduct. This contract is to be completed by March next. The remainder of the works about to be entered upon include a new canal and flood channel about 1,447 yards long, and the deepening and widening of the River Soar for a length of about 920 yards, with two or three bridges.

[1]

Abstract from the presidential address delivered before the Association of Municipal and Sanitary Engineers and Surveyors, at the annual meeting in Leicester, July 18, 1887.

THE CHEMISTRY OF THE COTTON FIBER.

By Dr. BOWMAN.

Every chemist knows that cotton is chiefly composed of cellulose, $C_6H_{10}O_5$, with some other substances in smaller quantities. This, although the usual opinion, is only true in a partial sense, as the author found on investigating samples of cotton from various sources. Thus, while mere cellulose contains carbon 44.44 per cent. and hydrogen 6.173, he found in Surat cotton 7.6 per cent. of hydrogen, in American cotton 6.3 per cent., and in Egyptian cotton 7.2 per cent. The fact is that along with cellulose in ordinary cotton there are a number of celluloid bodies derived from the inspissated juices of the cotton plant.

In order to gain information on this subject, the author has grown cotton under glass, and analyzed it at various stages of its life history. In the early stage of unripeness he has found an astringent substance in the fiber. This substance disappears as the plant ripens, and seems to closely resemble some forms of tannin. Doubtless the presence of this body in cotton put upon the market in an unripe condition may account for certain dark stains sometimes appearing in the finished calicoes. The tannin matter forms dark stains with any compound or salt of iron, and is a great bugbear to the manufacturer. Some years ago there was quite a panic because of the prevalence of these stains, and people in Yorkshire began to think the spinners were using some new or inferior kind of oil. Dr. Bowman made inquiries, and found that in Egypt during that year the season had been very foggy and unfavorable to the ripening of the cotton, and it seemed probable that these tannin-like matters were present in the fiber, and led to the disastrous results.

Although the hydrogen and oxygen present in pure cellulose are in the same relative proportions as in water, they do not exist as water in the compound. There is, however, in cotton a certain amount of water present in a state of loose combination with the cellulose, and the celluloid bodies previously referred to appear to contain water similarly combined, but in greater proportion. Oxycellulose is another body present in the cotton fiber. It is a triple cellulose, in which four atoms of hydrogen are replaced by one atom of oxygen, and like cellulose forms nitro compounds analogous to nitro glycerine. It is probable that the presence of this oxycellulose has a marked influence upon the behavior of cotton, especially with dye matters. The earthy substances in cotton are also of importance. These are potassium carbonate, chloride, and sulphate, with similar sodium salts, and these vary in different samples of cotton, and possibly influence its properties to some extent. Then there are oily matters in the young fiber which, upon its ripening, become the waxy matter which Dr. Schunk has investigated. Resin also is present, and having a high melting point is not removed by the manipulative processes that cotton is subjected to. When this is in excessive amount, it comes to the surface of the goods after dyeing.

SYNTHESIS OF STYROLENE.

MM. Vabet and Vienne, in a recent number of *Comptes Rendus*, state that by passing a current of acetylene through 200 grammes of benzene containing 50 grammes of aluminum chloride for 30 hours the oily liquid remaining after removal of the unaltered aluminum chloride by washing was found to yield, on fractional distillation, three distinct products. The first, which came over between 143° and 145° , and which amounted to 80 per cent. of the whole, consisted of pure cinnamene or styrolene ($C_6H_5.CH.CH_2$), which is one of the principal constituents of liquid storax, and was synthesized by M. Berthelot by passing acetylene and benzene vapor through a tube heated to redness. The second fraction, coming over at 265° - 270° , consisted of diphenyl ethane ($(C_6H_5)_2 CH.CH_3$); and the third fraction, boiling at 280° - 286° , was found to consist entirely of dibenzyl ($C_6H_5.CH_2.CH_2.C_6H_5$), a solid substance isomeric with diphenyl ethane. These syntheses afford another instance of the singular action of aluminum chloride in attacking the benzene nucleus.

NOTES ON SACCHARIN.

By EDWARD D. GRAVILL, F.C.S., F.R.M.S.

Now that a supply of this reputed substitute for sugar has been placed upon the London market, it will doubtless have attracted the attention of many pharmacists, and as information having reference to its characters and properties is as yet somewhat scarce, the following notes may be of interest.

The sample to which these notes refer represents, I believe, a portion of the first

supply that has been offered to us as a commercial article, and may therefore be taken to represent the same as it at present occurs in commerce. I think it desirable to call attention to this fact, because of the wide difference I have seen in other samples obtained, I think, by special request some weeks ago, and which do not favorably correspond with the sample under consideration, being much more highly colored, and in comparison having a very strong odor. Saccharin now occurs as a very pale yellow, nearly white, amorphous powder, free from grittiness, but giving a distinct sensation of roughness when rubbed between the fingers. It is not entirely free from odor, but this is very slight, and not at all objectionable, reminding one of a very slight flavor of essential oils of almonds. Its taste is intensely sweet and persistent, which in the raw state is followed by a slight harshness upon the tongue and palate. The sweetness is very distinct when diluted to 1 in 10,000. Under the microscope it presents no definite form of crystallization.

A temperature of 100° C, even if continued for some time, has no perceptible effect upon saccharin; it loses no weight, and undergoes no physical change. It fuses at a temperature of from 118° to 120° C., and at 150° C. forms a clear light yellow liquid, which boils a few degrees higher. At the latter temperature dense white fumes appear, and a condensation of tufts of acicular crystals (some well defined) is found upon the cool surface of the apparatus. These crystals, except for a slight sweetness of taste, correspond in characters and tests to benzoic acid. The sweet flavor, I think, may be due to the presence of a very small quantity of undecomposed saccharin, carried mechanically with the fumes. The escaping vapors, which are very irritable, and give a more decided odor of hydride of benzole than the powder itself, also communicate a very distinct sensation of sweetness to the back part of the palate. Heated over the flame, with free access of air, saccharin carbonizes and burns with a dull yellow smoky flame, leaving a residue amounting to 0.65 per cent. of sodium salts. It does not reduce an alkaline copper solution, but, like glycerine, liberates boracic acid from borax, the latter salt dissolving saccharin readily in aqueous solution, due no doubt to a displacement of the boracic acid.

The strong acids, either hot or cold, show no characteristic color reaction; the compound enters solution at the boiling point of the acid, and in the case of hydrochloric shows a white granular separation on cooling. Sulphuric acid develops an uncharacteristic light brown color.

The compound, like most of the organic acids, shows a characteristic reaction with ferro and ferrid cyanide of potassium. In the former case no change is perceptible until boiled when a greenish white turbidity appears, with the liberation of small quantities of hydrocyanic acid. In the latter case a trace also of this acid is set free, with the formation of a very distinct green solution, the latter reaction being very perceptible with a few drops of a 1 in 1,000 solution of saccharin in water. Heated with lime, very distinct odors of benzoic aldehyde are developed.

Saccharin possesses very decided acid properties, and combines readily with alkalis or alkaline carbonates, forming anhydro-ortho sulphamine-benzoates of the same, in the latter case at the expense of the carbonic anhydride, causing strong effervescence. These combinations are very soluble in water, the alkaline carbonate thus forming a ready medium for the solution of this acid, which alone is so sparingly soluble. Another advantage of some importance is that, while the harshness of flavor perceptible in a simple solution of the acid is destroyed, the great sweetness appears to be distinctly intensified and refined.

The following shows the solubility of saccharin in the various liquids quoted, all, with the exception of the boiling water, being taken at 60° F.:

Boiling water	0.60 parts per 100 by volume.	
Cold water	0.20	"
Alcohol 0.800	4.25	"
Rectified spirit 0.838	3.20	"
Ether 0.717	1.00	"
Chloroform 1.49	0.20	"
Benzene	0.40	"
Petroleum ether	insoluble.	

It is also sparingly soluble in glycerin and fixed oils, and to a greater or less extent in volatile oils. Benzoic aldehyde dissolves saccharin in large quantities.

I was somewhat disappointed at the slight solubility of saccharin in ether, as it has been repeatedly stated to be very soluble in that liquid.

The quantity of saccharin required to communicate an agreeable degree of sweetness, like sugar, differs with the material to be sweetened; but from half to one and half grains, according to taste, will be found sufficient for an ordinary breakfast cup full of tea or coffee infusion.—*Pharm. Jour.*

ALCOHOL AND TURPENTINE.

In a paper entitled "The Oxidation of Ethyl Alcohol in the Presence of Turpentine," communicated to the Chemical Society by Mr. C.E. Steedman, Williamstown, Victoria, the author states that dilute ethyl alcohol in the presence of air and turpentine becomes oxidized to acetic acid. He placed in a clear glass 16 oz. bottle a mixture of 2 drachms of alcohol, 1 drachm of turpentine, and 1 oz. of water. The bottle was securely corked and left exposed to a varying temperature averaging about 80° F. for three months. At the end of that time the liquid was strongly acid from the presence of acetic acid. One curious fact appears to have light thrown upon it by this observation.

Mr. McAlpine, Professor of Biology at Ormond College, Melbourne University, has a method of preserving biological specimens by abstracting their moisture with alcohol after hardening in chromic acid, and then placing the specimen in turpentine for some time; great discrepancies arise, however, according as the alcohol is allowed or not to evaporate from the specimen before dipping it into turpentine.

THE SCIENTIFIC AMERICAN

Architects and Builders Edition.

\$2.50 a Year. Single Copies, 25 cts.

This is a Special Edition of the SCIENTIFIC AMERICAN, issued monthly—on the first day of the month. Each number contains about forty large quarto pages, equal to about two hundred ordinary book pages, forming, practically, a large and splendid **Magazine of Architecture**, richly adorned with *elegant plates in colors* and with fine engravings, illustrating the most interesting examples of modern Architectural Construction and allied subjects.

A special feature is the presentation in each number of a variety of the latest and best plans for private residences, city and country, including those of very moderate cost as well as the more expensive. Drawings in perspective and in color are given, together with full Plans, Specifications, Costs, Bills of Estimate, and Sheets of Details.

No other building paper contains so many plans, details, and specifications regularly presented as the SCIENTIFIC AMERICAN. Hundreds of dwellings have already been erected on the various plans we have issued during the past year, and many others are in process of construction.

Architects, Builders, and Owners will find this work valuable in furnishing fresh and useful suggestions. All who contemplate building or improving homes, or erecting structures of any kind, have before them in this work an almost *endless series of the latest and best examples* from which to make selections, thus saving time and money.

Many other subjects, including Sewerage, Piping, Lighting, Warming, Ventilating, Decorating, Laying out of Grounds, etc., are illustrated. An extensive Compendium of Manufacturers' Announcements is also given, in which the most reliable and approved Building Materials, Goods, Machines, Tools, and Appliances are described and illustrated, with addresses of the makers, etc.

The fullness, richness, cheapness, and convenience of this work have won for it the **Largest Circulation** of any Architectural publication in the world.

**MUNN & CO., Publishers,
361 Broadway, New York.**

A Catalogue of valuable books on Architecture, Building, Carpentry, Masonry, Heating, Warming, Lighting, Ventilation, and all branches of industry pertaining to the art of Building, is supplied free of charge, sent to any address.

Building Plans and Specifications.

In connection with the publication of the BUILDING EDITION of the SCIENTIFIC AMERICAN, Messrs. Munn & Co. furnish plans and specifications for buildings of every kind, including Churches, Schools, Stores, Dwellings, Carriage Houses, Barns, etc.

In this work they are assisted by able and experienced architects. Full plans, details, and specifications for the various buildings illustrated in this paper can be supplied.

Those who contemplate building, or who wish to alter, improve, extend, or add to existing buildings, whether wings, porches, bay windows, or attic rooms, are invited to communicate with the undersigned. Our work extends to all parts of the country. Estimates, plans, and drawings promptly prepared. Terms moderate. Address

MUNN & CO., 361 BROADWAY. NEW YORK.

**The
Scientific American Supplement.**

PUBLISHED WEEKLY.

Terms of Subscription, \$5 a year.

Sent by mail, postage prepaid, to subscribers in any part of the United States or Canada. Six dollars a year, sent, prepaid, to any foreign country.

All the back numbers of THE SUPPLEMENT, from the commencement, January 1, 1876, can be had. Price, 10 cents each.

All the back volumes of THE SUPPLEMENT can likewise be supplied. Two volumes are issued yearly. Price of each volume, \$2.50 stitched in paper, or \$3.50 bound in stiff covers.

COMBINED RATES.—One copy of SCIENTIFIC AMERICAN and one copy of SCIENTIFIC AMERICAN SUPPLEMENT, one year, postpaid, \$7.00.

A liberal discount to booksellers, news agents, and canvassers.

**MUNN & CO., Publishers,
361 Broadway, New York, N.Y.**

PATENTS.

In connection with the **Scientific American**, Messrs. MUNN & CO. are solicitors of American and Foreign Patents, have had 42 years' experience, and now have the largest establishment in the world. Patents are obtained on the best terms.

A special notice is made in the **Scientific American** of all inventions patented through this Agency, with the name and residence of the Patentee. By the immense circulation thus given, public attention is directed to the merits of the new patent, and sales or introduction often easily effected.

Any person who has made a new discovery or invention can ascertain, free of charge, whether a patent can probably be obtained, by writing to MUNN & Co.

We also send free our Hand Book about the Patent Laws, Patents, Caveats, Trade Marks, their costs, and how procured. Address

**MUNN & CO.,
361 Broadway, New York.**

Branch Office, 622 and 624 F St., Washington, D.C.

*** END OF THE PROJECT GUTENBERG EBOOK SCIENTIFIC AMERICAN
SUPPLEMENT, NO. 620, NOVEMBER 19, 1887 ***

Updated editions will replace the previous one—the old editions will be renamed.

Creating the works from print editions not protected by U.S. copyright law means that no one owns a United States copyright in these works, so the Foundation (and you!) can copy and distribute it in the United States without permission and without paying copyright royalties. Special rules, set forth in the General Terms of Use part of this license, apply to copying and distributing Project Gutenberg™ electronic works to protect the PROJECT GUTENBERG™ concept and trademark. Project Gutenberg is a registered trademark, and may not be used if you charge for an eBook, except by following the terms of the

trademark license, including paying royalties for use of the Project Gutenberg trademark. If you do not charge anything for copies of this eBook, complying with the trademark license is very easy. You may use this eBook for nearly any purpose such as creation of derivative works, reports, performances and research. Project Gutenberg eBooks may be modified and printed and given away—you may do practically ANYTHING in the United States with eBooks not protected by U.S. copyright law. Redistribution is subject to the trademark license, especially commercial redistribution.

START: FULL LICENSE
THE FULL PROJECT GUTENBERG LICENSE
PLEASE READ THIS BEFORE YOU DISTRIBUTE OR USE THIS WORK

To protect the Project Gutenberg™ mission of promoting the free distribution of electronic works, by using or distributing this work (or any other work associated in any way with the phrase “Project Gutenberg”), you agree to comply with all the terms of the Full Project Gutenberg™ License available with this file or online at www.gutenberg.org/license.

Section 1. General Terms of Use and Redistributing Project Gutenberg™ electronic works

1.A. By reading or using any part of this Project Gutenberg™ electronic work, you indicate that you have read, understand, agree to and accept all the terms of this license and intellectual property (trademark/copyright) agreement. If you do not agree to abide by all the terms of this agreement, you must cease using and return or destroy all copies of Project Gutenberg™ electronic works in your possession. If you paid a fee for obtaining a copy of or access to a Project Gutenberg™ electronic work and you do not agree to be bound by the terms of this agreement, you may obtain a refund from the person or entity to whom you paid the fee as set forth in paragraph 1.E.8.

1.B. “Project Gutenberg” is a registered trademark. It may only be used on or associated in any way with an electronic work by people who agree to be bound by the terms of this agreement. There are a few things that you can do with most Project Gutenberg™ electronic works even without complying with the full terms of this agreement. See paragraph 1.C below. There are a lot of things you can do with Project Gutenberg™ electronic works if you follow the terms of this agreement and help preserve free future access to Project Gutenberg™ electronic works. See paragraph 1.E below.

1.C. The Project Gutenberg Literary Archive Foundation (“the Foundation” or PGLAF), owns a compilation copyright in the collection of Project Gutenberg™ electronic works. Nearly all the individual works in the collection are in the public domain in the United States. If an individual work is unprotected by copyright law in the United States and you are located in the United States, we do not claim a right to prevent you from copying, distributing, performing, displaying or creating derivative works based on the work as long as all references to Project Gutenberg are removed. Of course, we hope that you will support the Project Gutenberg™ mission of promoting free access to electronic works by freely sharing Project Gutenberg™ works in compliance with the terms of this agreement for keeping the Project Gutenberg™ name associated with the work. You can easily comply with the terms of this agreement by keeping this work in the same format with its attached full Project Gutenberg™ License when you share it without charge with others.

1.D. The copyright laws of the place where you are located also govern what you can do with this work. Copyright laws in most countries are in a constant state of change. If you are outside the United States, check the laws of your country in addition to the terms of this agreement before downloading, copying, displaying, performing, distributing or creating derivative works based on this work or any other Project Gutenberg™ work. The Foundation makes no representations concerning the copyright status of any work in any country other than the United States.

1.E. Unless you have removed all references to Project Gutenberg:

1.E.1. The following sentence, with active links to, or other immediate access to, the full Project Gutenberg™ License must appear prominently whenever any copy of a Project Gutenberg™ work (any work on which the phrase “Project Gutenberg” appears, or with which the phrase “Project Gutenberg” is associated) is accessed, displayed, performed, viewed, copied or distributed:

This eBook is for the use of anyone anywhere in the United States and most other parts of the world at no cost and with almost no restrictions

whatsoever. You may copy it, give it away or re-use it under the terms of the Project Gutenberg License included with this eBook or online at www.gutenberg.org. If you are not located in the United States, you will have to check the laws of the country where you are located before using this eBook.

1.E.2. If an individual Project Gutenberg™ electronic work is derived from texts not protected by U.S. copyright law (does not contain a notice indicating that it is posted with permission of the copyright holder), the work can be copied and distributed to anyone in the United States without paying any fees or charges. If you are redistributing or providing access to a work with the phrase “Project Gutenberg” associated with or appearing on the work, you must comply either with the requirements of paragraphs 1.E.1 through 1.E.7 or obtain permission for the use of the work and the Project Gutenberg™ trademark as set forth in paragraphs 1.E.8 or 1.E.9.

1.E.3. If an individual Project Gutenberg™ electronic work is posted with the permission of the copyright holder, your use and distribution must comply with both paragraphs 1.E.1 through 1.E.7 and any additional terms imposed by the copyright holder. Additional terms will be linked to the Project Gutenberg™ License for all works posted with the permission of the copyright holder found at the beginning of this work.

1.E.4. Do not unlink or detach or remove the full Project Gutenberg™ License terms from this work, or any files containing a part of this work or any other work associated with Project Gutenberg™.

1.E.5. Do not copy, display, perform, distribute or redistribute this electronic work, or any part of this electronic work, without prominently displaying the sentence set forth in paragraph 1.E.1 with active links or immediate access to the full terms of the Project Gutenberg™ License.

1.E.6. You may convert to and distribute this work in any binary, compressed, marked up, nonproprietary or proprietary form, including any word processing or hypertext form. However, if you provide access to or distribute copies of a Project Gutenberg™ work in a format other than “Plain Vanilla ASCII” or other format used in the official version posted on the official Project Gutenberg™ website (www.gutenberg.org), you must, at no additional cost, fee or expense to the user, provide a copy, a means of exporting a copy, or a means of obtaining a copy upon request, of the work in its original “Plain Vanilla ASCII” or other form. Any alternate format must include the full Project Gutenberg™ License as specified in paragraph 1.E.1.

1.E.7. Do not charge a fee for access to, viewing, displaying, performing, copying or distributing any Project Gutenberg™ works unless you comply with paragraph 1.E.8 or 1.E.9.

1.E.8. You may charge a reasonable fee for copies of or providing access to or distributing Project Gutenberg™ electronic works provided that:

- You pay a royalty fee of 20% of the gross profits you derive from the use of Project Gutenberg™ works calculated using the method you already use to calculate your applicable taxes. The fee is owed to the owner of the Project Gutenberg™ trademark, but he has agreed to donate royalties under this paragraph to the Project Gutenberg Literary Archive Foundation. Royalty payments must be paid within 60 days following each date on which you prepare (or are legally required to prepare) your periodic tax returns. Royalty payments should be clearly marked as such and sent to the Project Gutenberg Literary Archive Foundation at the address specified in Section 4, “Information about donations to the Project Gutenberg Literary Archive Foundation.”
- You provide a full refund of any money paid by a user who notifies you in writing (or by e-mail) within 30 days of receipt that s/he does not agree to the terms of the full Project Gutenberg™ License. You must require such a user to return or destroy all copies of the works possessed in a physical medium and discontinue all use of and all access to other copies of Project Gutenberg™ works.
- You provide, in accordance with paragraph 1.F.3, a full refund of any money paid for a work or a replacement copy, if a defect in the electronic work is discovered and reported to you within 90 days of receipt of the work.
- You comply with all other terms of this agreement for free distribution of Project Gutenberg™ works.

1.E.9. If you wish to charge a fee or distribute a Project Gutenberg™ electronic

work or group of works on different terms than are set forth in this agreement, you must obtain permission in writing from the Project Gutenberg Literary Archive Foundation, the manager of the Project Gutenberg™ trademark. Contact the Foundation as set forth in Section 3 below.

1.F.

1.F.1. Project Gutenberg volunteers and employees expend considerable effort to identify, do copyright research on, transcribe and proofread works not protected by U.S. copyright law in creating the Project Gutenberg™ collection. Despite these efforts, Project Gutenberg™ electronic works, and the medium on which they may be stored, may contain “Defects,” such as, but not limited to, incomplete, inaccurate or corrupt data, transcription errors, a copyright or other intellectual property infringement, a defective or damaged disk or other medium, a computer virus, or computer codes that damage or cannot be read by your equipment.

1.F.2. LIMITED WARRANTY, DISCLAIMER OF DAMAGES - Except for the “Right of Replacement or Refund” described in paragraph 1.F.3, the Project Gutenberg Literary Archive Foundation, the owner of the Project Gutenberg™ trademark, and any other party distributing a Project Gutenberg™ electronic work under this agreement, disclaim all liability to you for damages, costs and expenses, including legal fees. YOU AGREE THAT YOU HAVE NO REMEDIES FOR NEGLIGENCE, STRICT LIABILITY, BREACH OF WARRANTY OR BREACH OF CONTRACT EXCEPT THOSE PROVIDED IN PARAGRAPH 1.F.3. YOU AGREE THAT THE FOUNDATION, THE TRADEMARK OWNER, AND ANY DISTRIBUTOR UNDER THIS AGREEMENT WILL NOT BE LIABLE TO YOU FOR ACTUAL, DIRECT, INDIRECT, CONSEQUENTIAL, PUNITIVE OR INCIDENTAL DAMAGES EVEN IF YOU GIVE NOTICE OF THE POSSIBILITY OF SUCH DAMAGE.

1.F.3. LIMITED RIGHT OF REPLACEMENT OR REFUND - If you discover a defect in this electronic work within 90 days of receiving it, you can receive a refund of the money (if any) you paid for it by sending a written explanation to the person you received the work from. If you received the work on a physical medium, you must return the medium with your written explanation. The person or entity that provided you with the defective work may elect to provide a replacement copy in lieu of a refund. If you received the work electronically, the person or entity providing it to you may choose to give you a second opportunity to receive the work electronically in lieu of a refund. If the second copy is also defective, you may demand a refund in writing without further opportunities to fix the problem.

1.F.4. Except for the limited right of replacement or refund set forth in paragraph 1.F.3, this work is provided to you ‘AS-IS’, WITH NO OTHER WARRANTIES OF ANY KIND, EXPRESS OR IMPLIED, INCLUDING BUT NOT LIMITED TO WARRANTIES OF MERCHANTABILITY OR FITNESS FOR ANY PURPOSE.

1.F.5. Some states do not allow disclaimers of certain implied warranties or the exclusion or limitation of certain types of damages. If any disclaimer or limitation set forth in this agreement violates the law of the state applicable to this agreement, the agreement shall be interpreted to make the maximum disclaimer or limitation permitted by the applicable state law. The invalidity or unenforceability of any provision of this agreement shall not void the remaining provisions.

1.F.6. INDEMNITY - You agree to indemnify and hold the Foundation, the trademark owner, any agent or employee of the Foundation, anyone providing copies of Project Gutenberg™ electronic works in accordance with this agreement, and any volunteers associated with the production, promotion and distribution of Project Gutenberg™ electronic works, harmless from all liability, costs and expenses, including legal fees, that arise directly or indirectly from any of the following which you do or cause to occur: (a) distribution of this or any Project Gutenberg™ work, (b) alteration, modification, or additions or deletions to any Project Gutenberg™ work, and (c) any Defect you cause.

Section 2. Information about the Mission of Project Gutenberg™

Project Gutenberg™ is synonymous with the free distribution of electronic works in formats readable by the widest variety of computers including obsolete, old, middle-aged and new computers. It exists because of the efforts of hundreds of volunteers and donations from people in all walks of life.

Volunteers and financial support to provide volunteers with the assistance they need are critical to reaching Project Gutenberg™’s goals and ensuring that the Project Gutenberg™ collection will remain freely available for generations to

come. In 2001, the Project Gutenberg Literary Archive Foundation was created to provide a secure and permanent future for Project Gutenberg™ and future generations. To learn more about the Project Gutenberg Literary Archive Foundation and how your efforts and donations can help, see Sections 3 and 4 and the Foundation information page at www.gutenberg.org.

Section 3. Information about the Project Gutenberg Literary Archive Foundation

The Project Gutenberg Literary Archive Foundation is a non-profit 501(c)(3) educational corporation organized under the laws of the state of Mississippi and granted tax exempt status by the Internal Revenue Service. The Foundation's EIN or federal tax identification number is 64-6221541. Contributions to the Project Gutenberg Literary Archive Foundation are tax deductible to the full extent permitted by U.S. federal laws and your state's laws.

The Foundation's business office is located at 809 North 1500 West, Salt Lake City, UT 84116, (801) 596-1887. Email contact links and up to date contact information can be found at the Foundation's website and official page at www.gutenberg.org/contact

Section 4. Information about Donations to the Project Gutenberg Literary Archive Foundation

Project Gutenberg™ depends upon and cannot survive without widespread public support and donations to carry out its mission of increasing the number of public domain and licensed works that can be freely distributed in machine-readable form accessible by the widest array of equipment including outdated equipment. Many small donations (\$1 to \$5,000) are particularly important to maintaining tax exempt status with the IRS.

The Foundation is committed to complying with the laws regulating charities and charitable donations in all 50 states of the United States. Compliance requirements are not uniform and it takes a considerable effort, much paperwork and many fees to meet and keep up with these requirements. We do not solicit donations in locations where we have not received written confirmation of compliance. To SEND DONATIONS or determine the status of compliance for any particular state visit www.gutenberg.org/donate.

While we cannot and do not solicit contributions from states where we have not met the solicitation requirements, we know of no prohibition against accepting unsolicited donations from donors in such states who approach us with offers to donate.

International donations are gratefully accepted, but we cannot make any statements concerning tax treatment of donations received from outside the United States. U.S. laws alone swamp our small staff.

Please check the Project Gutenberg web pages for current donation methods and addresses. Donations are accepted in a number of other ways including checks, online payments and credit card donations. To donate, please visit: www.gutenberg.org/donate

Section 5. General Information About Project Gutenberg™ electronic works

Professor Michael S. Hart was the originator of the Project Gutenberg™ concept of a library of electronic works that could be freely shared with anyone. For forty years, he produced and distributed Project Gutenberg™ eBooks with only a loose network of volunteer support.

Project Gutenberg™ eBooks are often created from several printed editions, all of which are confirmed as not protected by copyright in the U.S. unless a copyright notice is included. Thus, we do not necessarily keep eBooks in compliance with any particular paper edition.

Most people start at our website which has the main PG search facility: www.gutenberg.org.

This website includes information about Project Gutenberg™, including how to make donations to the Project Gutenberg Literary Archive Foundation, how to help produce our new eBooks, and how to subscribe to our email newsletter to hear about new eBooks.