

**The Project Gutenberg eBook of Scientific American Supplement,
No. 643, April 28, 1888, by Various**

This ebook is for the use of anyone anywhere in the United States and most other parts of the world at no cost and with almost no restrictions whatsoever. You may copy it, give it away or re-use it under the terms of the Project Gutenberg License included with this ebook or online at www.gutenberg.org. If you are not located in the United States, you'll have to check the laws of the country where you are located before using this eBook.

Title: Scientific American Supplement, No. 643, April 28, 1888

Author: Various

Release date: September 7, 2005 [EBook #16671]
Most recently updated: December 12, 2020

Language: English

Credits: Produced by Juliet Sutherland and the Online Distributed Proofreading Team at www.pgdp.net

*** START OF THE PROJECT GUTENBERG EBOOK SCIENTIFIC AMERICAN
SUPPLEMENT, NO. 643, APRIL 28, 1888 ***



**SCIENTIFIC AMERICAN
SUPPLEMENT NO. 643**

NEW YORK, APRIL 28, 1888

Scientific American Supplement. Vol. XXV., No. 643.

Scientific American established 1845

Scientific American Supplement, \$5 a year.

Scientific American and Supplement, \$7 a year.

TABLE OF CONTENTS.

TABLE OF CONTENTS

- | | | |
|------|--|-------|
| I. | ARCHÆOLOGY.—The Subterranean Temples of India.—The subterranean temples of India described and illustrated, the wonderful works of the ancient dwellers in Hindostan.—3 illustrations. | 10275 |
| II. | BIOGRAPHY.—General F. Perrier.—Portrait and biography of the French geodesian, his triangulations in Algiers and Corsica.—1 illustration. | 10264 |
| | The Crown Prince of Germany—Prince William and his son.—Biographical note of Prince William, the heir to the German throne.—1 illustration. | 10263 |
| III. | BIOLOGY.—Poisons.—Abstract of a lecture by Prof. MEYMOTT TIDY, giving the relations of poisons to life. | 10273 |

	<u>The President's Annual Address to the Royal Microscopical Society. — The theory of putrefaction and putrefactive organisms. — Exhaustive review of the subject.</u>	10264
IV.	<u>CHEMISTRY.—Molecular Weights.—A new and simple method of determining molecular weights for unvolatilizable substances.</u>	10271
V.	<u>CIVIL ENGINEERING.—Concrete.—By JOHN LUNDIE.—A practical paper on the above subject.—The uses and proper methods of handling concrete, machine mixing contrasted with hand mixing.</u>	10267
	<u>Timber and Some of its Diseases.—By H. MARSHALL WARD.— The continuation of this important treatise on timber destruction, the fungi affecting wood, and treatment of the troubles arising therefrom.</u>	10277
VI.	<u>ENGINEERING.—Estrade's High Speed Locomotive.—A comparative review of the engineering features of M. Estrade's new engine, designed for speeds of 77 to 80 miles an hour.—1 illustration.</u>	10266
	<u>Machine Designing.—By JOHN B. SWEET.—First portion of a Franklin Institute lecture on this eminently practical subject.—2 illustrations.</u>	10267
VII.	<u>METEOROLOGY.—The Peak of Teneriffe.—Electrical and meteorological observations on the summit of Teneriffe.</u>	10265
VIII.	<u>MISCELLANEOUS.—Analysis of a Hand Fire Grenade.—By CHAS. CATLETT and R.C. PRICE.—The contents of a fire grenade and its origin.</u>	10271
	<u>How to Catch and Preserve Moths and Butterflies.—Practical directions for collectors.</u>	10275
	<u>The Clavi Harp.—A new instrument, a harp played by means of keys arranged on a keyboard—1 illustration.</u>	10275
	<u>Inquiries Regarding the Incubator.—By P.H. JACOBS.—Notes concerning the incubator described in a previous issue (SUPPLEMENT, No. 630).—Practical points.</u>	10265
IX.	<u>PHYSICS.—The Direct Optical Projection of Electro-dynamic Lines of Force, and other Electro-dynamic Phenomena.—By Prof. J.W. MOORE— Second portion of this profusely illustrated paper, giving a great variety of experiments on the phenomena of loop-shaped conductors.—26 illustrations.</u>	10272
	<u>The Mechanics of a Liquid.—An ingenious method of measuring the volume of fibrous and porous substances without immersion in any liquid.—1 illustration.</u>	10269
X.	<u>PHYSIOLOGY.—Artificial Mother for Infants.—An apparatus resembling an incubator for infants that are prematurely born.—Results attained by its use.—1 illustration.</u>	10274
	<u>Gastrostomy.—Artificial feeding for cases of obstructed œsophagus.— The apparatus and its application.—2 illustrations.</u>	10274
XI.	<u>PHOTOGRAPHY.—How to Make Photo-Printing Plates.—The process of making relief plates for printers.</u>	10271
XII.	<u>TECHNOLOGY.—Improved Current Meter.—A simple apparatus for measuring air and water currents without indexes or other complications.—1 illustration.</u>	10270
	<u>The Flower Industry of Grasse.—Methods of manufacturing perfumes in France.—The industry as practiced in the town of Grasse.</u>	10270
	<u>Volute Double Distilling Condenser.—A distiller and condenser for producing fresh water from sea water.—3 illustrations.</u>	10269
	<u>The Argand Burner.—The origin of the invention of the Argand burner.</u>	10275



THE CROWN PRINCE OF GERMANY—PRINCE WILLIAM AND SON [From a Photograph]

THE CROWN PRINCE OF GERMANY—PRINCE WILLIAM AND HIS SON.

At a moment when the entire world has its eyes fixed upon the invalid of the Villa Zurio, it appears to us to be of interest to publish the portrait of his son, Prince William. The military spirit of the Hohenzollerns is found in him in all its force and exclusiveness. It was hoped that the accession of the crown prince to the throne of Germany would temper the harshness of it and modernize its aspect, but the painful disease from which he is suffering warns us that the moment may soon come in which the son will be called to succeed the Emperor William, his grandfather, of whom he is morally the perfect portrait. Like him, he loves the army, and makes it the object of his entire attention. No colonel more scrupulously performs his duty than he, when he enters the quarters of the regiment of red hussars whose chief he is.

His solicitude for the army manifests itself openly. It is not without pride that he regards his eldest son, who will soon be six years old, and who is already clad in the uniform of a fusilier of the Guard. Prince William is a soldier in spirit, just as harsh toward himself as severe toward others. So he is the friend and emulator of Prince Von Bismarck, who sees in him the depository of the military traditions of the house of Prussia, and who is preparing him by his lessons and his advice to receive and preserve the patrimony that his ancestors have conquered.

Prince William was born January 27, 1859. On the 29th of February, 1881, he married Princess Augusta Victoria, daughter of the Duke of Sleswick-Holstein. Their eldest son, little Prince William, represented with his father in our engraving, was born at Potsdam, May 6, 1882.—*L'Illustration*.

GENERAL F. PERRIER.

Francois Perrier, who was born at Valleraugue (Gard), on the 18th of April, 1835, descended from an honorable family of Protestants, of Cevennes. After finishing his studies at the Lyceum of Nimes and at St. Barbe College, he was received at the Polytechnic School in 1853, and left it in 1857, as a staff officer.

Endowed with perseverance and will, he owed all his grades and all his success to his splendid conduct and his important labors. Lieutenant in 1857, captain in 1860, major of cavalry in 1874, lieutenant-colonel in 1879, he received a year before his death the stars of brigadier-general. He was commander of the Legion of Honor and president of the council-general of his department.

General Perrier long ago made a name for himself in science. After some remarkable publications upon the trigonometrical junction of France and England (1861) and upon the triangulation and leveling of Corsica (1865), he was put at the head of the geodesic service of the army in 1879. In 1880, the learned geodesian was sent as a delegate to the conference of Berlin for settling the boundaries of the new Greco-Turkish frontiers. In January of the same year, he was elected a member of the Academy of Sciences, as successor to M. De Tesson. He was a member of the bureau of longitudes from 1875.

In 1882, Perrier was sent to Florida to observe the transit of Venus. Thanks to his activity and ability, his observations were a complete success. Thenceforward, his celebrity continued to increase until his last triangulating operations in Algeria.



GENERAL FRANCOIS PERRIER.

"Do you not remember," said Mr. Janssen recently to the Academy of Sciences, "the feeling of satisfaction that the whole country felt when it learned the entire success of that grand geodesic operation that united Spain with our Algeria over the Mediterranean, and passed through France a meridian arc extending from the north of England as far as to the Sahara, that is to say, an arc exceeding in length the greatest arcs that had been measured up till then? This splendid result attracted all minds, and rendered Perrier's name popular. But how much had this success been prepared by long and conscientious labors that cede in nothing to it in importance? The triangulation and leveling of Corsica, and the connecting of it with the Continent; the splendid operations executed in Algeria, which required fifteen years of labor, and led to the measurement of an arc of parallels of nearly 10° in extent, that offers a very peculiar interest for the study of the earth's figure; and, again, that revision of the meridian of France in which it became necessary to utilize all the progress that had been made since the beginning of the century in the construction of instruments and in methods of observation and calculation. And it must be added that General Perrier had formed a school of scientists and devoted officers who were his co-laborers, and upon whom we must now rely to continue his work."

The merits of General Perrier gained him the honor of being placed at the head of a service of high importance, the geographical service of the army, to the organization of which he devoted his entire energy.

In General Perrier, the man ceded in nothing to the worker and scientist. Good, affable, generous, he joined liveliness and good humor with courage and energy. Incessantly occupied with the prosperity and grandeur of his country, he knew that true patriotism does not consist in putting forth vain declamations, but in

endeavoring to accomplish useful and fruitful work.—*La Nature*.

General Perrier died at Montpellier on the 20th of February, 1888.

THE PRESIDENT'S ANNUAL ADDRESS TO THE ROYAL MICROSCOPICAL SOCIETY.¹

Retrospect may involve regret, but can scarcely involve anxiety. To one who fully appreciates the actual, and above all the potential, importance of this society in its bearing upon the general progress of scientific research in every field of physical inquiry, the responsibilities of president will not be lightly, while they may certainly be proudly, undertaken.

I think it may be now fairly taken for granted that, as this society has, from the outset, promoted and pointed to the higher scientific perfection of the microscope, so now, more than ever, it is its special function to place this in the forefront as its *raison d'etre*. The microscope has been long enough in the hands of amateur and expert alike to establish itself as an instrument having an application to every actual and conceivable department of human research; and while in the earliest days of this society it was possible for a zealous Fellow to have seen, and been more or less familiar with, all the applications to which it then had been put, it is different to-day. Specialists in the most diverse areas of research are assiduously applying the instrument to their various subjects, and with results that, if we would estimate aright, we must survey with instructed vision the whole ground which advancing science covers.

From this it is manifest that this society cannot hope to infold, or at least to organically bind to itself, men whose objects of research are so diverse.

But these are all none the less linked by one inseverable bond; it is the microscope; and while, amid the inconceivable diversity of its applications, it remains manifest that this society has for its primary object the constant progress of the instrument—whether in its mechanical construction or its optical appliances; whether the improvements shall bear upon the use of high powers or low powers; whether it shall be improvement that shall apply to its commercial employment, its easier professional application, or its most exalted scientific use; so long as this shall be the undoubted aim of the Royal Microscopical Society, its existence may well be the pride of Englishmen, and will commend itself more and more to men of all countries.

This, and this only, can lift such a society out of what I believe has ceased to be its danger, that of forgetting that in proportion as the optical principles of the microscope are understood, and the theory of microscopical vision is made plain, the value of the instrument over every region to which it can be applied, and in all the varied hands that use it, is increased without definable limit. It is therefore by such means that the true interests of science are promoted.

It is one of the most admirable features of this society that it has become cosmopolitan in its character in relation to the instrument, and all the ever-improving methods of research employed with it. From meeting to meeting it is not one country, or one continent even, that is represented on our tables. Nay, more, not only are we made familiar with improvements brought from every civilized part of the world, referring alike to the microscope itself and every instrument devised by specialists for its employment in every department of research; but also, by the admirable persistence of Mr. Crisp and Mr. Jno. Mayall, Jr., we are familiarized with every discovery of the old forms of the instrument wherever found or originally employed.

The value of all this cannot be overestimated, for it will, even where prejudices as to our judgment may exist, gradually make it more and more clear that this society exists to promote and acknowledge improvements in every constituent of the microscope, come from whatever source they may; and, in connection with this, to promote by demonstrations, exhibitions, and monographs the finest applications of the finest instruments for their respective purposes.

To give all this its highest value, of course, the theoretical side of our instrument must occupy the attention of the most accomplished experts. We may not despair that our somewhat too practical past in this respect may right itself in our own country; but meantime the splendid work of German students and experts is placed by the wise editors of our journal within the reach of all.

I know of no higher hope for this important society than that it may continue in ever increasing strength to promote, criticise, and welcome from every quarter of the world whatever will improve the microscope in itself and in any of its applications, from the most simple to the most complex and important in which its employment is possible.

There are two points of some practical interest to which I desire for a few moments to call your attention. The former has reference to the group of organisms to which I have for so many years directed your attention, viz., the "monads," which throughout I have called "putrefactive organisms."

There can be no longer any doubt that the destructive process of putrefaction is essentially a process of fermentation.

The fermentative saprophyte is as absolutely essential to the setting up of destructive rotting or putrescence in a putrescible fluid as the torula is to the setting up of alcoholic fermentation in a saccharine fluid. Make the presence of torulæ impossible, and you exclude with certainty fermentative action.

In precisely the same way, provide a proteinaceous solution, capable of the highest putrescence, but absolutely sterilized, and placed in an optically pure or absolutely calcined air; and while these conditions are maintained, no matter what length of time may be suffered to elapse, the putrescible fluid will remain absolutely without trace of decay.

But suffer the slightest infection of the protected and pure air to take place, or, from some putrescent source, inoculate your sterilized fluid with the minutest atom, and shortly turbidity, offensive scent, and destructive putrescence ensue.

As in the alcoholic, lactic, or butyric ferments, the process set up is shown to be dependent upon and concurrent with the vegetative processes of the demonstrated organisms characterizing these ferments; so it can be shown with equal clearness and certainty that the entire process of what is known as putrescence is equally and as absolutely dependent on the vital processes of a given and discoverable series of organisms.

Now it is quite customary to treat the fermentative agency in putrefaction as if it were wholly bacterial, and, indeed, the putrefactive group of bacteria are now known as saprophytes, or saprophytic bacteria, as distinct from morphologically similar, but physiologically dissimilar, forms known as parasitic or pathogenic bacteria.

It is indeed usually and justly admitted that *B. termo* is the exciting cause of fermentative putrefaction. Cohn has in fact contended that it is the distinctive ferment of all putrefactions, and that it is to decomposing proteinaceous solutions what *Torula cerevisiæ* is to the fermenting fluids containing sugar.

In a sense, this is no doubt strictly true: it is impossible to find a decomposing proteinaceous solution, at any stage, without finding this form in vast abundance.

But it is well to remember that in nature putrefactive ferments must go on to an extent rarely imitated or followed in the laboratory. As a rule, the pabulum in which the saprophytic organisms are provided and "cultured" is infusions, or extracts of meat carefully filtered, and, if vegetable matter is used, extracts of fruit, treated with equal care, and if needful neutralized, are used in a similar way. To these may be added all the forms of gelatine, employed in films, masses and so forth.

But in following the process of destructive fermentation as it takes place in large masses of tissue, animal or vegetable, but far preferably the former, as they lie in water at a constant temperature of from 60° to 65° F., it will be seen that the fermentative process is the work, not of one organism, nor, judging by the standard of our present knowledge, of one specified class of vegetative forms, but by organisms which, though related to each other, are in many respects greatly dissimilar, not only morphologically, but also embryologically, and even physiologically.

Moreover, although this is a matter that will want most thorough and efficient inquiry and research to understand properly its conditions, yet it is sufficiently manifest that these organisms succeed each other in a curious and even remarkable manner. Each does a part in the work of fermentative destruction; each aids in splitting up into lower and lower compounds the elements of which the masses of degrading tissue are composed; while, apparently, each set in turn does by vital action, coupled with excretion, (1) take up the substances necessary for its own growth and multiplication; (2) carry on the fermentative process; and (3) so change the immediate pabulum as to give rise to conditions suitable for its immediate successor. Now the point of special interest is that there is an apparent adaptation in the form, functions, mode of multiplication, and order of succession in these fermentative organisms, deserving study and fraught with instruction.

Let it be remembered that the aim of nature in this fermentative action is not the partial splitting of certain organic compounds, and their reconstruction in simpler conditions, but the ultimate setting free, by saprophytic action, of the elements locked up in great masses of organic tissue—the sending back into nature of the only

material of which future organic structures are to be composed.

I have said that there can be no question whatever that *Bacterium termo* is the pioneer of saprophytes. Exclude *B. termo* (and therefore with it all its congeners), and you can obtain no putrefaction. But wherever, in ordinary circumstances, a decomposable organic mass, say the body of a fish, or a considerable mass of the flesh of a terrestrial animal, is exposed in water at a temperature of 60° to 65° F., *B. termo* rapidly appears, and increases with a simply astounding rapidity. It clothes the tissues like a skin, and diffuses itself throughout the fluid.

The exact chemical changes it thus effects are not at present clearly known; but the fermentative action is manifestly concurrent with its multiplication. It finds its pabulum in the mass it ferments by its vegetative processes. But it also produces a visible change in the enveloping fluid, and noxious gases continuously are thrown off.

In the course of a week or more, dependent on the period of the year, there is, not inevitably, but as a rule, a rapid accession of spiral forms, such as *Spirillum volutans*, *S. undula*, and similar forms, often accompanied by *Bacterium lineola*; and the whole interspersed still with inconceivable multitudes of *B. termo*.

These invest the rotting tissues like an elastic garment, but are always in a state of movement. These, again, manifestly further the destructive ferment, and bring about a softness and flaccidity in the decomposing tissues, while they without doubt, at the same time, have, by their vital activity and possible secretions, affected the condition of the changing organic mass. There can be, so far as my observations go, no certainty as to when, after this, another form of organism will present itself; nor, when it does, which of a limited series it will be. But, in a majority of observed cases, a loosening of the living investment of bacterial forms takes place, and simultaneously with this, the access of one or two forms of my putrefactive monads. They were among the first we worked at; and have been, by means of recent lenses, among the last revised. Mr. S. Kent named them *Cercomonas typica* and *Monas dallingeri* respectively. They are both simple oval forms, but the former has a flagellum at both ends of the longer axis of the body, while the latter has a single flagellum in front.

The principal difference is in their mode of multiplication by fission. The former is in every way like a bacterium in its mode of self-division. It divides, acquiring for each half a flagellum in division, and then, in its highest vigor, in about four minutes, each half divides again.

The second form does not divide into two, but into many, and thus although the whole process is slower, develops with greater rapidity. But both ultimately multiply—that is, commence new generations—by the equivalent of a sexual process.

These would average about four times the size of *Bacterium termo*; and when once they gain a place on and about the putrefying tissues, their relatively powerful and incessant action, their enormous multitude, and the manner in which they glide over, under, and beside each other, as they invest the fermenting mass, is worthy of close study. It has been the life history of these organisms, and not their relations as ferment, that has specially occupied my fullest attention; but it would be in a high degree interesting if we could discover, or determine, what besides the vegetative or organic processes of nutrition are being effected by one, or both, of these organisms on the fast yielding mass. Still more would it be of interest to discover what, if any, changes were wrought in the pabulum, or fluid generally. For after some extended observations I have found that it is only after one or other or both, of these organisms have performed their part in the destructive ferment, that subsequent and extremely interesting changes arise.

It is true that in some three or four instances of this saprophytic destruction of organic tissues, I have observed that, after the strong bacterial investment, there has arisen, not the two forms just named, nor either of them, but one or other of the striking forms now called *Tetramitus rostratus* and *Polytoma uvella*; but this has been in relatively few instances. The rule is that *Cercomonas typica* or its congener precedes other forms, that not only succeed them in promoting and carrying to a still further point the putrescence of the fermenting substance, but appear to be aided in the accomplishment of this by mechanical means.

By this time the mass of tissue has ceased to cohere. The mass has largely disintegrated, and there appears among the countless bacterial and monad forms some one, and sometimes even three forms, that while they at first swim and gyrate, and glide about the decomposing matter, which is now much less closely invested by *Cercomonas typica*, or those organisms that may have acted in its place, they also resort to an entirely new mode of movement.

One of these forms is *Heteromita rostrata*, which, it will be remembered, in addition to a front flagellum, has also a long fiber or flagellum-like appendage that gracefully

trails as it swims. At certain periods of its life they anchor themselves in countless billions all over the fermenting tissues, and as I have described in the life history of this form, they coil their anchored fiber, as does a vorticellan, bringing the body to the level of the point of anchorage, then shoot out the body with lightning-like rapidity, and bring it down like a hammer on some point of the decomposition. It rests here for a second or two, and repeats the process; and this is taking place by what seems almost like rhythmic movement all over the rotting tissue. The results are scarcely visible in the mass. But if a group of these organisms be watched, attached to a small particle of the fermenting tissue, it will be seen to gradually diminish, and at length to disappear.

Now, there are at least two other similar forms, one of which, *Heteromita uncinata*, is similar in action, and the other of which, *Dallingeria drysdali*, is much more powerful, being possessed of a double anchor, and springing down upon the decadent mass with relatively far greater power.

Now, it is under the action of these last forms that in a period varying from one month to two or three the entire substance of the organic tissues disappears, and the decomposition has been designated by me "exhausted"; nothing being left in the vessel but slightly noxious and pale gray water, charged with carbonic acid, and a fine, buff colored, impalpable sediment at the bottom.

My purpose is not, by this brief notice, to give an exhaustive, or even a sufficient account, of the progress of fermentative action, by means of saprophytic organisms, on great masses of tissue; my observations have been incidental, but they lead me to the conclusion that the fermentative process is not only not carried through by what are called saprophytic bacteria, but that a *series* of fermentative organisms arise, which succeed each other, the earlier ones preparing the pabulum or altering the surrounding medium, so as to render it highly favorable to a succeeding form. On the other hand, the succeeding form has a special adaptation for carrying on the fermentative destruction more efficiently from the period at which it arises, and thus ultimately of setting free the chemical elements locked up in dead organic compounds.

That these later organisms are saprophytic, although not bacterial, there can be no doubt. A set of experiments, recorded by me in the proceedings of this society some years since, would go far to establish this (*Monthly Microscopical Journal*, 1876, p. 288). But it may be readily shown, by extremely simple experiments, that these forms will set up fermentative decomposition rapidly if introduced in either a desiccated or living condition, or in the spore state, into suitable but sterilized pabulum.

Thus while we have specific ferments which bring about definite and specific results, and while even infusions of proteid substances may be exhaustively fermented by saprophytic bacteria, the most important of all ferments, that by which nature's dead organic masses are removed, is one which there is evidence to show is brought about by the successive vital activities of a series of adapted organisms, which are forever at work in every region of the earth.

There is one other matter of some interest and moment on which I would say a few words. To thoroughly instructed biologists, such words will be quite needless; but, in a society of this kind, the possibilities that lie in the use of the instrument are associated with the contingency of large error, especially in the biology of the minuter forms of life, unless a well grounded biological knowledge form the basis of all specific inference, to say nothing of deduction.

I am the more encouraged to speak of the difficulty to which I refer, because I have reason to know that it presents itself again and again in the provincial societies of the country, and is often adhered to with a tenacity worthy of a better cause. I refer to the danger that always exists, that young or occasional observers are exposed to, amid the complexities of minute animal and vegetable life, of concluding that they have come upon absolute evidences of the transformation of one minute form into another; that in fact they have demonstrated cases of heterogenesis.

This difficulty is not diminished by the fact that on the shelves of most microscopical societies there is to be found some sort of literature written in support of this strange doctrine.

You will pardon me for allusion again to the field of inquiry in which I have spent so many happy hours. It is, as you know, a region of life in which we touch, as it were, the very margin of living things. If nature were capricious anywhere, we might expect to find her so here. If her methods were in a slovenly or only half determined condition, we might expect to find it here. But it is not so. Know accurately what you are doing, use the precautions absolutely essential, and through years of the closest observation it will be seen that the vegetative and vital processes generally, of the very simplest and lowliest life forms, are as much directed and controlled by immutable laws as the most complex and elevated.

The life cycles, accurately known, of monads repeat themselves as accurately as those of rotifers or planarians.

And of course, on the very surface of the matter, the question presents itself to the biologist why it should not be so. The irrefragable philosophy of modern biology is that the most complex forms of living creatures have derived their splendid complexity and adaptations from the slow and majestically progressive variation and survival from the simpler and the simplest forms. If, then, the simplest forms of the present and the past were not governed by accurate and unchanging laws of life, how did the rigid certainties that manifestly and admittedly govern the more complex and the most complex come into play?

If our modern philosophy of biology be, as we know it is, true, then it must be very strong evidence indeed that would lead us to conclude that the laws seen to be universal break down and cease accurately to operate where the objects become microscopic, and our knowledge of them is by no means full, exhaustive, and clear.

Moreover, looked at in the abstract, it is a little difficult to conceive why there should be more uncertainty about the life processes of a group of lowly living things than there should be about the behavior, in reaction, of a given group of molecules.

The triumph of modern knowledge is the certainty, which nothing can shake, that nature's laws are immutable. The stability of her processes, the precision of her action, and the universality of her laws, is the basis of all science, to which biology forms no exception. Once established, by clear and unmistakable demonstration, the life history of an organism, and truly some change must have come over nature as a whole, if that life history be not the same to-morrow as to-day; and the same to one observer, in the same conditions, as to another.

No amount of paradox would induce us to believe that the combining proportions of hydrogen and oxygen had altered, in a specified experimenter's hands, in synthetically producing water.

We believe that the melting point of platinum and the freezing point of mercury are the same as they were a hundred years ago, and as they will be a hundred years hence.

Now, carefully remember that so far as we can see at all, it must be so with life. Life inheres in protoplasm; but just as you cannot get *abstract matter*—that is, matter with no properties or modes of motion—so you cannot get *abstract* protoplasm. Every piece of living protoplasm we see has a history; it is the inheritor of countless millions of years. Its properties have been determined by its history. It is the protoplasm of some definite form of life which has inherited its specific history. It can be no more false to that inheritance than an atom of oxygen can be false to its properties.

All this, of course, within the lines of the great secular processes of the Darwinian laws; which, by the way, could not operate at all if caprice formed any part of the activities of nature.

But let me give a practical instance of how what appears like fact may override philosophy, if an incident, or even a group of incidents, *per se* are to control our judgment.

Eighteen years ago I was paying much attention to vorticellæ. I was observing with some pertinacity *Vorticella convallaria*; for one of the calices in a group under observation was in a strange and semi-encysted state, while the remainder were in full normal activity.

I watched with great interest and care, and have in my folio still the drawings made at the time. The stalk carrying this individual calyx fell upon the branch of vegetable matter to which the vorticellan was attached, and the calyx became perfectly globular; and at length there emerged from it a small form with which, in this condition, I was quite unfamiliar; it was small, tortoise-like in form, and crept over the branch on setæ or hair-like pedicels; but, carefully followed, I found it soon swam, and at length got the long neck-like appendage of *Amphileptus anser*!

Here then was the cup or calyx of a definite vorticellan form changing into (?) an absolutely different infusorian, viz., *Amphileptus anser*!

Now I simply reported the *fact* to the Liverpool Microscopical Society, with no attempt at inference; but two years after I was able to explain the mystery, for, finding in the same pond both *V. convallaria* and *A. anser*, I carefully watched their movements, and saw the *Amphileptus* seize and struggle with a calyx of *convallaria*, and absolutely become encysted upon it, with the results that I had reported two years before.

And there can be no doubt but this is the key to the cases that come to us again and again of minute forms suddenly changing into forms wholly unlike. It is happily among the virtues of the man of science to "rejoice in the truth," even though it be found at his expense; and true workers, earnest seekers for nature's methods, in the obscurest fields of her action, will not murmur that this source of danger to younger microscopists has been pointed out, or recalled to them.

And now I bid you, as your president, farewell. It has been all pleasure to me to serve you. It has enlarged my friendships and my interests, and although my work has linked me with the society for many years, I have derived much profit from this more organic union with it; and it is a source of encouragement to me, and will, I am sure, be to you, that, after having done with simple pleasure what I could, I am to be succeeded in this place of honor by so distinguished a student of the phenomena of minute life as Dr. Hudson. I can but wish him as happy a tenure of office as mine has been.

[1]

Delivered by the Rev. Dr. Dallinger, F.R.S., at the annual meeting of the Royal Microscopical Society, Feb. 8, 1888.—*Nature*.

INQUIRIES REGARDING THE INCUBATOR.

P.H. JACOBS.

Space in the *Rural* is valuable, and so important a subject as artificial incubation cannot perhaps be made entirely plain to a novice in a few articles; but as interested parties have written for additional information, it may interest others to answer them here. Among the questions asked are: "Does the incubator described in the *Rural* dispense entirely with the use of a lamp, using at intervals a bucket of water to maintain proper temperature? I fear this will not be satisfactory unless the incubator is kept in a warm room or cellar."

All incubators must be kept in a warm location, whether operated by a lamp or otherwise. The warmer the room or cellar, the less warmth required to be supplied. Bear in mind that the incubator recommended has four inches of sawdust surrounding it, and more sawdust would still be an advantage. The sawdust is not used to protect against the outside temperature, but to absorb and hold a large amount of heat, and that is the secret of its success. The directions given were to first fill the tank with boiling water and allow it to remain for 24 hours. In the meantime the sawdust absorbs the heat, and more boiling water is then added until the egg-drawer is about 110 or 115 degrees. By this time there is a quantity of stored heat in the sawdust. The eggs will cool the drawer to 103. The loss of heat (due to its being held by the sawdust) will be very slow. All that is needed then is to supply that which will be lost in 12 hours, and a bucket of boiling water should keep the heat about correct, if added twice a day, but it may require more, as some consideration must be given to fluctuations of the temperature of the atmosphere. The third week of incubation, owing to animal heat from the embryo chicks, a bucket of boiling water will sometimes hold temperature for 24 hours. No objection can be urged against attaching a lamp arrangement, but a lamp is dangerous at night, while the flame must be regulated according to temperature. The object of giving the hot water method was to avoid lamps. We have a large number of them in use (no lamps) here, and they are equal to any others in results.

With all due respect to some inquirers, the majority of them seem afraid of the work. Now, there is some work with all incubators. What is desired is to get rid of the anxiety. I stated that a bucket of water twice a day would suffice. I trusted to the judgment of the reader somewhat. Of course, if the heat in the egg drawer is 90 degrees, and the weather cold, it may then take a wash boiler full of water to get the temperature back to 103 degrees, but when it is at 103 keep it there, even if it occasionally requires two buckets of boiling water. To judge of what may be required, let us suppose the operator looks at the thermometer in the morning, and it is exactly 103 degrees. He estimates that it will lose a little by night, and draws off half a bucket of water. At night he finds it at 102. Knowing that it is on what we term "the down grade," he applies a bucket and a half (always allowing for the night being colder than the day). As stated, the sawdust will not allow the drawer to become too cold, as it gives off heat to the drawer. And, as the sawdust absorbs, it is not easy to have the heat too high. One need not even look at the drawer until the proper times. No watching—the incubator regulates itself. If a lamp is used, too much heat may accumulate. The flame must be occasionally turned up or down, and the operator must remain at home and watch it, while during the third week he will easily cook his eggs.

The incubator can be made at home for so small a sum (about \$5 for the tank, \$1 for

faucet, etc., with 116 feet of lumber) that it will cost but little to try it. A piece of glass can be placed in front of the egg drawer, if preferred. If the heat goes down to 90, or rises at times to 105, no harm is done. But it works well, and hatches, the proof being that hundreds are in use. I did not give the plan as a theory or an experiment. They are in practical use here, and work alongside of the more expensive ones, and have been in use for four years. To use a lamp attachment, all that is necessary is to have a No. 2 burner lamp with a riveted sheet-iron chimney, the chimney fitting over the flame, like an ordinary globe, and extending the chimney (using an elbow) through the tank from the rear, ending in front. It should be soldered at the tank. The heat from the lamp will then pass through the chimney and consequently warm the surrounding water.—*Rural New-Yorker*.

[For description and illustrations of this incubator see SUPPLEMENT, No. 630.]

THE PEAK OF TENERIFFE.

The Hon. Ralph Abercromby made a trip to the island of Teneriffe in October, 1887, for the purpose of making some electrical and meteorological observations, and now gives some of the results which he obtained, which may be summarized as follows: The electrical condition of the peak of Teneriffe was found to be the same as in every other part of the world. The potential was moderately positive, from 100 to 150 volts, at 5 ft. 5 in. from the ground, even at considerable altitudes; but the tension rose to 549 volts on the summit of the peak, 12,200 ft., and to 247 volts on the top of the rock of Gayga, 7,100 feet. A large number of halos were seen associated with local showers and cloud masses. The necessary ice dust appeared to be formed by rising currents. The shadow of the peak was seen projected against the sky at sunset. The idea of a southwest current flowing directly over the northeast trade was found to be erroneous. There was always a regular vertical succession of air currents in intermediate directions at different levels from the surface upward, so that the air was always circulating on a complicated screw system.

ESTRADE'S HIGH SPEED LOCOMOTIVE.

We illustrate a very remarkable locomotive, which has been constructed from the designs of M. Estrade, a French engineer. This engine was exhibited last year in Paris. Although the engine was built, M. Estrade could not persuade any railway company to try it for him, and finally he applied to the French government, who have at last sanctioned the carrying out of experiments with it on one of the state railway lines. The engine is in all respects so opposed to English ideas that we have hitherto said nothing about it. As, however, it is going to be tried, an importance is given to it which it did not possess before; and, as a mechanical curiosity, we think it is worth the consideration of our readers.

In order that we may do M. Estrade no injustice, we reproduce here in a condensed form, and in English, the arguments in its favor contained in a paper written by M. Max de Nansouty, C.E., who brought M. Estrade's views before the French Institution of Civil Engineers, on May 21, 1886. M. Nansouty's paper has been prepared with much care, and contains a great deal of useful data quite apart from the Estrade engine. The paper in question is entitled "*Memoire relatif au Materiel Roulant a Grand Vitesse*," D.M. Estrade.

About thirty years ago, M. Estrade, formerly pupil of the Polytechnic School, invented rolling stock for high speed under especial conditions, and capable of leading to important results, more especially with regard to speed. Following step by step the progress made in the construction of railway stock, the inventor, from time to time, modified and improved his original plan, and finally, in 1884, arrived at the conception of a system entirely new in its fundamental principles and in its execution. A description of this system is the object of the memoir.

The great number of types of locomotives and carriages now met with in France, England, and the United States renders it difficult to combine their advantages, as M. Estrade proposed to do, in a system responding to the requirements of the constructor. His principal object, however, has been to construct, under specially favorable conditions, a locomotive, tender, and rolling stock adapted to each other, so as to establish a perfect accord between these organs when in motion. It is, in fact, a complete train, and not, as sometimes supposed, a locomotive only, of an especial type, which has been the object he set before him. Before entering into other considerations, we shall first give a description of the stock proposed by M. Estrade. The idea of the invention consists in the use of coupled wheels of large diameter and in the adoption of a new system of double suspension.

The locomotive and tender we illustrate were constructed by MM. Boulet & Co. The

locomotive is carried on six driving wheels, 8 feet 3 inches in diameter. The total weight of the engine is thus utilized for adhesion. The accompanying table gives the principal dimensions:

TABLE I.

	ft.	in.
Total length of engine.	32	8
Width between frames.	4	1
Wheel base, total.	16	9
Diameter of cylinder.	1	6½
Length of stroke.	2	3½
Grate surface.	25 sq. feet.	
Total heating surface.	1,400 sq. ft.	
Weight empty.	38 tons.	
Weight full.	42 tons.	

The high speeds—77 to 80 miles an hour—in view of which this stock has been constructed have, it will be seen, caused the elements relative to the capacity of the boiler and the heating surfaces to be developed as much as possible. It is in this, in fact, that one of the great difficulties of the problem lies, the practical limit of stability being fixed by the diameter of the driving wheels. Speed can only be obtained by an expenditure of steam which soon becomes such as rapidly to exhaust the engine unless the heating surface is very large.

The tender, also fitted with wheels of 8 ft. 3 in. in diameter, offers no particular feature; it is simply arranged so as to carry the greatest quantity of coal and water.

M. Estrade has also designed carriages. One has been constructed by MM. Reynaud, Bechade, Gire & Co., which has very few points in common with those in general use. Independently of the division of the compartments into two stories, wheels 8 ft. 3 in. in diameter are employed, and the double system of suspension adopted. Two axles, 16 ft. apart, support, by means of plate springs, an iron framing running from end to end over the whole length, its extremities being curved toward the ground. Each frame carries in its turn three other plate springs, to which the body is suspended by means of iron tie-rods serving to support it. This is then a double suspension, which at once appears to be very superior to the systems adopted up to the present time. The great diameter of the wheels has necessitated the division into two stories. The lower story is formed of three equal parts, lengthened toward the axles by narrow compartments, which can be utilized for luggage or converted into lavatories, etc. Above is one single compartment with a central passage, which is reached by staircases at the end. All the vehicles of the same train are to be united at this level by jointed platforms furnished with hand rails. It is sufficient to point out the general disposition, without entering into details which do not affect the system, and which must vary for the different classes and according to the requirements of the service.

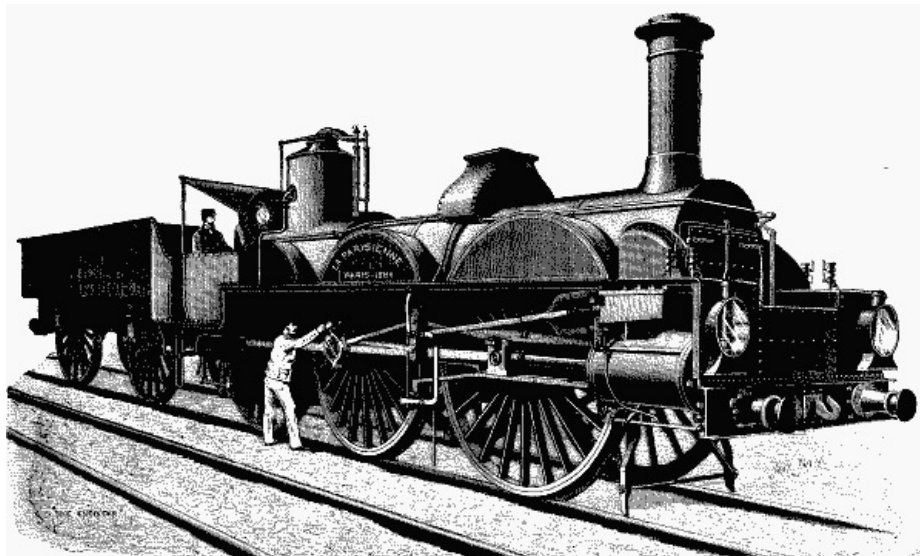

M. ESTRADÉ'S HIGH SPEED LOCOMOTIVE.

M. Nansouty draws a comparison between the diameters of the driving wheels and cylinders of the principal locomotives now in use and those of the Estrade engine as set forth in the following table. We only give the figures for coupled engines:

TABLE II.

	Diameter of driving wheels.		Size of cylinder.	Position of cylinder.
	ft.	in.	in. in.	
Great Eastern	7	0	18 × 24	inside
South-Eastern	7	0	19 × 26	"
Glasgow and Southwestern	6	1	18 × 26	"
Midland, 1884	7	0	19 × 26	"
North-Eastern	7	0	17½ × 24	"
London and North-Western	6	6	17 × 24	"
Lancashire and Yorkshire	6	0	17½ × 26	"
Nord	7	0	17 × 24	"
Paris-Orleans, 1884	6	8	17 × 23½	outside.
Ouest	6	0	17¼ × 25½	"

This table, the examination of which will be found very instructive, shows that there are already in use: (1) for locomotives with single drivers, diameters of 9 ft., 8 ft. 1 in., and 8 ft.; (2) for locomotives with four coupled wheels, diameters 6 ft. to 7 ft. There is therefore an important difference between the diameters of the coupled wheels of 7 ft. and those of 8 ft. 3 in., as conceived by M. Estrade. However, the transition is not illogically sudden, and if the conception is a bold one, "it cannot," says M. Nansouty, "on the other hand, be qualified as rash."

He goes on to consider, in the first place: Especial types of uncoupled wheels, the diameters of which form useful samples for our present case. The engines of the Bristol and Exeter line are express tender engines, adopted on the English lines in 1853, some specimens of which are still in use.¹ These engines have ten wheels, the single drivers in the center, 9 ft. in diameter, and a four-wheeled bogie at each end. The driving wheels have no flanges. The bogie wheels are 4 ft. in diameter. The cylinders have a diameter of 16½ in. and a piston stroke of 24 in. The boiler contains 180 tubes, and the total weight of the engine is 42 tons. These locomotives, constructed for 7 ft. gauge, have attained a speed of seventy-seven miles per hour.

The single driver locomotives of the Great Northern are powerful engines in current use in England. The driving wheels carry 17 tons, the heating surface is 1,160 square feet, the diameters of the cylinders 18 in., and that of the driving wheels 8 ft. 1 in. We have here, then, a diameter very near to that adopted by M. Estrade, and which, together with the previous example, forms a precedent of great interest. The locomotive of the Great Northern has a leading four-wheeled bogie, which considerably increases the steadiness of the engine, and counterbalances the disturbing effect of outside cylinders. Acting on the same principles which have animated M. Estrade, that is to say, with the aim of reducing the retarding effects of rolling friction, the constructor of the locomotive of the Great Northern has considerably increased the diameter of the wheels of the bogie. In this engine all the bearing are inside, while the cylinders are outside and horizontal. The tender has six wheels, also of large dimensions. It is capable of containing three tons and a half of coal and about 3,000 gallons of water. This type of engine is now in current and daily use in England.

M. Nansouty next considers the broad gauge Great Western engines with 8 ft. driving wheels. The diameters of their wheels approach those of M. Estrade, and exceed considerably in size any lately proposed. M. Nansouty dwells especially upon the boiler power of the Great Western railway, because one of the objections made to M. Estrade's locomotive by the learned societies has been the difficulty of supplying boiler power enough for high speeds contemplated; and he deals at considerable length with a large number of English engines of maximum power, the dimensions and performance of which are too well known to our readers to need reproduction here.

Aware that a prominent weak point in M. Estrade's design is that, no matter what size we make cylinders and wheels, we have ultimately to depend on the boiler for power, M. Nansouty argues that M. Estrade having provided more surface than is to be found in any other engine, must be successful. But the total heating surface in the engine, which we illustrate, is but 1,400 square feet, while that of the Great Western engines, on which he lays such stress, is 2,300 square feet, and the table which he gives of the heating surface of various English engines really means very little. It is quite true that there are no engines working in England with much over 1,500 square feet of surface, except those on the broad gauge, but it does not follow that because they manage to make an average of 53 miles an hour that an addition of 500 square feet would enable them to run at a speed higher by 20 miles an hour. There are engines in France, however, which have as much as 1,600 square feet, as, for example, on the Paris-Orleans line, but we have never heard that these engines attain a speed of 80 miles an hour.

Leaving the question of boiler power, M. Nansouty goes on to consider the question of adhesion. About this he says:

Is the locomotive proposed by M. Estrade under abnormal conditions as to weight and adhesion? This appears to have been doubted, especially taking into consideration its height and elegant appearance. We shall again reply here by figures, while remarking that the adhesion of locomotives increases with the speed, according to laws still unknown or imperfectly understood, and that consequently for extreme speeds, ignorance of the value of the coefficient of adhesion f in the formula

$$fP = 0.65 p \frac{d^2 I}{D} - R$$

renders it impossible to pronounce upon it before the trials earnestly and justly demanded by the author of this new system. In present practice $f = 1/7$ is admitted. M. Nansouty gives in a table a *resume* of the experience on this subject, and goes on:

"The English engineers, as will be seen, make a single axle support more than 17 tons. In France the maximum weight admitted is 14 tons, and the constructor of the Estrade locomotive has kept a little below this figure. The question of total weight appears to be secondary in a great measure, for, taking the models with uncoupled wheels, the English engines for great speed have on an average, for a smaller total weight, an adhesion equal to that of the French locomotives. The P.L.M. type of engine, which has eight wheels, four of which are coupled, throws only 28.6 tons upon the latter, being 58 per cent. of the total weight. On the other hand, that of the English Great Eastern throws 68 per cent. of the total weight on the driving wheels. Numerous other examples could be cited. We cannot, we repeat, give an opinion rashly as to the calculation of adhesion for the high speed Estrade locomotive before complete trials have taken place which will enable us to judge of the particular coefficients for this entirely new case."

M. Nansouty then goes on to consider the question of curves, and says:

"It has been asked, not without reason, notably by the Institution of Civil Engineers of Paris, whether peculiar difficulties will not be met with by M. Estrade's locomotive—with its three axles and large coupled wheels—in getting round curves. We have seen in the preceding tables that the driving wheels of the English locomotives with independent wheels are as much as 8 ft. in diameter. The driving wheels of the English locomotives with four coupled wheels are 7 ft. in diameter. M. Estrade's locomotive has certainly six coupled wheels with diameters never before tried, but these six coupled wheels constitute the whole rolling length, while in the above engines a leading axle or a bogie must be taken into account, independent, it is true, but which must not be lost sight of, and which will in a great measure equalize the difficulties of passing over the curves.

"Is it opposed to absolute security to attack the line with driving wheels? This generally admitted principle appears to rest rather on theoretic considerations than on the results of actual experience. M. Estrade, besides, sets in opposition to the disadvantages of attacking the rails with driving wheels those which ensue from the use of wheels of small diameter as liable to more wear and tear. We should further note with particular care that the leading axle of this locomotive has a certain transverse play, also that it is a driving axle. This disposition is judicious and in accordance with the best known principles."

A careful perusal of M. Nansouty's memoir leaves us in much doubt as to what M. Estrade's views are based on. So far as we understand him, he seems to have worked on the theory that by the use of very large wheels the rolling resistance of a train can be greatly diminished. On this point, however, there is not a scrap of evidence derived from railway practice to prove that any great advantage can be gained by augmenting the diameters of wheels. In the next place, he is afraid that he will not have adhesion enough to work up all his boiler power, and, consequently, he couples his wheels, thereby greatly augmenting the resistance of the engine. He forgets that large coupled wheels were tried years ago on the Great Western Railway, and did not answer. A single pair of drivers 8 ft. 3 in. in diameter would suffice to work up all the power M. Estrade's boiler could supply at sixty miles an hour, much less eighty miles an hour. On the London and Brighton line Mr. Stroudley uses with success coupled leading wheels of large diameter on his express engines, and we imagine that M. Estrade's engine will get round corners safely enough, but it is not the right kind of machine for eighty miles an hour, and so he will find out as soon as a trial is made. The experiment is, however, a notable experiment, and M. Estrade has our best wishes for his success.—*The Engineer*.

CONCRETE.¹

By JOHN LUNDIE.

The subject of cement and concrete has been so well treated of in engineering literature, that to give an extended paper on the subject would be but the collection and reiteration of platitudes familiar to every engineer who has been engaged on foundation works of any magnitude. It shall therefore be the object of this communication to place before the society several notes, stated briefly and to the point, rather as a basis for discussion than as an attempt at an exhaustive treatment of the subject.

Concrete is simply a low grade of masonry. It is a comparatively simple matter to trace the line of continuity from heavy squared ashlar blocks down through coursed and random rubble, to grouted indiscriminate rubble, and finally to concrete. Improvements in the manufacture of hydraulic cements have given an impetus to the use of concrete, but its use is by no means of recent date. It is no uncommon thing in the taking down of heavy walls several centuries old to find that the method of building was to carry up face and back with rubble and stiff mortar, and to fill the interior with bowlders and gravel, the interstices of which were filled by grouting—the whole mass becoming virtually a monolith. Modern quick-setting cement accomplishes this object within a time consistent with the requirements of modern engineering works; the formation of a monolithic mass within a reasonable time and with materials requiring as little handling as possible being the desideratum.

The materials of concrete as used at present are cement, sand, gravel, broken stone, and, of course, water. It is, perhaps, unnecessary to say that one of the primary requirements in materials is that they should be clean. Stone should be angular, gravel well washed, sand coarse and sharp, cement fine and possessing a fair proportion of the requirements laid down in the orthodox specification. The addition of lime water, saccharated or otherwise, has been suggested as an improvement over water pure and simple, but no satisfactory experiments are on record justifying the addition of lime water.

Regarding the mixing of cement and lime with saccharated water, the writer made some experiments several months ago by mixing neat cement and lime with pure water and with saccharated water, with the result that the sugar proved positively detrimental to the cement, while it increased the tenacity of briquettes of lime.

Stone which will pass a 2 inch is usually specified for ordinary concrete. It will be found that stone broken to this limit of size has fifty per cent. of its bulk voids. This space must be filled by mortar or preferably by gravel and mortar. If the mixing of concrete is perfect, the proportion of stone, by bulk, to other materials should be two to one. A percentage excess of other materials is, however, usually allowed to compensate for imperfection in mixing. While an excess of good mortar is not detrimental to concrete (as it will harden in course of time to equal the stone), still on the score of economy it is advisable to use gravel or a finer grade of stone in addition to the 2 inch ring stone to fill the interstices—gravel is cheaper than cement. The statement that excess in stone will give body to concrete is a fallacy hardly worth contradicting. In short, the proportion of material should be so graded that each particle of sand should have its jacket of cement, necessitating the cement being finer than the sand (this forms the mortar); then each pebble and stone should have its jacket of mortar. The smaller the interstices between the gravel and stones, the better. The quantity of water necessary to make good concrete is a sorely debated question. The quantity necessary depends on various considerations, and will probably be different for what appears to be the same proportion of materials. It is a well known fact that brick mortar is made very soft, and bricks are often wet before being laid, while a very hard stone is usually set with very stiff mortar. So in concrete the amount of water necessarily depends, to a great extent, on the porosity or dryness of the stone and other material used. But as to using a larger or smaller quantity of water with given materials, as a matter of observation it will be found that the water should only be limited by its effect in washing away mortar from the stone. Where can better concrete be found than that which has set under water? A certain definite amount of water is necessary and sufficient to hydrate the cement; less than that amount will be detrimental, while an excess can do no harm, provided, as before mentioned, that it does not wash the mortar from the stone. Again, dry concrete is apt to be very porous, which in certain positions is a very grave objection to it—this, not only from the fact of its porosity, but from the liability to disintegration from water freezing in the crevices.

Concrete, when ready to be placed in position, should be of the consistency of a pulpy mass which will settle into place by its own weight, every crevice being naturally filled. Pounding dry concrete is apt to break adjacent work, which will never again set properly. There should be no other object in pounding concrete than to assist it to settle into the place it is intended to fill. This is one of the evils concomitant with imperfection of mixing. The greater perfection of mixing attained, the nearer we get to the ideal monolith. The less handling concrete has after being mixed, the better. Immediately after the mass is mixed setting commences; therefore the sooner it is in position, the more perfect will be the hardened mass; and, on the other hand, the more it is handled, the more is the process interrupted and in like degree is the finished mass deteriorated. A low drop will be found the best method of placing a batch in position. Too much of a drop scatters the material and undoes the work of thorough mixing. Let the mass drop and then let it alone. If of proper temper, it will find its own place with very little trimming. Care should be taken to wet adjacent porous material, or the wooden form into which concrete is being placed; otherwise the water may be extracted from the concrete, to its detriment.

It has been found on removing boxing that the portion adjacent to the wood was frequently friable and of poor quality, owing to the fact just stated. It is usual to face or plaster concrete work after removing the boxing. On breakwater work, where the writer was engaged, the wall was faced with cement and flint grit, and this was found to form a particularly hard and lasting protection to the face of the work.

Batches of concrete should be placed in position as if they were stones in block masonry, as the union of one day's work with a previous is not by any means so perfect as where one batch is placed in contact with another which has not yet set. A slope cannot be added to with the same degree of perfection that one horizontal layer can be placed on another; consequently, where work must necessarily be interrupted, it should be stepped, and not sloped off.

Experience in concrete work has shown that its true place is in heavy foundations, retaining walls, and such like, and then perfectly independent of other material. Arches, thin walls, and such like are very questionable structures in continuous concrete, and are on record rather as failures than otherwise. This may to a certain degree be due to the high coefficient of expansion Portland cement concrete has by heat. This was found by Cunningham to be 0.000005 of its bulk for one degree Fahrenheit. It is a matter which any intelligent observer may remark, the invariable breakage of continuous concrete sidewalks, while those made in small sections remain good. This may be traced to expansion and contraction by heat, together with friction on the lower side.

In foundations, according to the same authority above quoted, properly made Portland cement concrete may be trusted with a safe load of 25 tons per square foot.

In large masses concrete should be worked continuously, while in small masses it should be moulded in small sections, which should be independent of each other and simply form artificial stones.

The facility with which concrete can be used in founding under water renders it particularly suitable for subaqueous structures. The method of dropping it from hopper barges in masses of 100 tons at a time, inclosed in a bag of coarse stuff, has been successfully employed by Dyce Cay and others. This can be carried on till the concrete appears above water, when the ordinary method of boxing can be employed to complete the work. This method was employed in the north pier breakwater at Aberdeen, the breakwater being founded on the sand, with a very broad base. The advantage of bags is apparent in the leveling off of an uneven foundation. In breakwater works on the Tay, in Scotland, where the writer was engaged, large blocks perforated vertically were employed. These were constructed below high water mark, and an air tight cover placed over them. They were lifted by pontoons as the tide rose, and conveyed to and deposited in place, the hollows being filled with air, serving to give buoyancy to the mass. After placing in position the vertical hollows were filled with concrete, so binding the whole together—they being placed vertically over each other.

As mentioned before, continuous stretches of concrete in small sections should be guarded against, owing to expansion by heat; but the fact of a few cracks appearing in heavy masses of concrete should not cause apprehension. These occur from unequal settlement and other causes. They should continue to be carefully grouted and faced until settlement is complete.

The use of concrete is becoming more and more general for foundation works. The desideratum hitherto has been a perfect and at the same time an economical mixer. Concrete can be mixed by hand and the materials well incorporated, but this is an expensive and man-killing method, as the handling of the wet mass by the shovel is extremely hard work, besides which the slowness of the method allows part of a large batch to set before the other is mixed, so that small batches, with attendant

extra handling, are necessary to make a good job. Mixers with a multiplicity of knives to toss the material have been used, but with little economical success. Of simple conveyers, such as a worm screw, little need be said; they are not mixers, and it seems a positive waste of time to pass material through a machine when it comes out in little better shape than it is put in. A box of the shape of a barrel has been used, it being trunnioned at the sides. The objection to this is that the material is thrown from side to side as a mass, there being a waste of energy in throwing about the material in mass without accomplishing an equivalent amount of mixing. Then a rectangular box has been used, trunnioned at opposite corners; but here the grave objection is that the concrete collects in the corners, and after a few turns it requires cleaning out, the material so sticking in the corners that it gets clogged up and ceases to mix.

The writer has just protected by letters patent a machine, in devising which the following objects were borne in mind:

1st. That every motion of the machine should do some useful work. Hitherto box or barrel mixers have gone on the principle of throwing the material about indiscriminately, expecting that somehow or other it would get mixed.

2d. That the sticking of the material anywhere within the mixer should be obviated.

3d. That an easy discharge should be obtained.

4th. That the water should be introduced while the mixer revolves.

With these desiderata in view, a box was designed which in half a turn gathers the material, then spreads it, and throws it from one side to the other at the same time that water is being introduced through a hollow trunnion.

It is also so constructed that all the sides slope steeply toward the discharge, and there is not a rectangular or acute angle within the box. A machine has now been worked steadily for several weeks, putting in the concrete in the foundations of the new Jackson Street bridge in this city, by General Fitz-Simons. The result exceeds expectations. The concrete is perfectly mixed, the discharge is simple, complete and effective, and at the same time the cost of labor in mixing and placing in position is lessened by 50 per cent. as compared with any known to have been put in under similar circumstances.—*Jour. Association of Engineering Societies.*

[1]

Read July 5, 1887, before the Western Society of Engineers.

MACHINE DESIGNING.¹

By JOHN E. SWEET.

"Carrying coals to Newcastle," the oft quoted comparison, fittingly indicates the position I place myself in when attempting to address members of this Institute on the subject of machine designing.

Philadelphia, the birthplace of the great and nearly all the good work in this, the noblest of all industrial arts, needs no help or praise at my hands, but I hope her sons may be prevailed upon to do in their right way what I shall try to do roughly—that is, formulate some rules or establish principles by which we, who are not endowed with genius, may so gauge our work as to avoid doing that which is truly bad. No great author was ever made by studying grammar, rhetoric, language, history, or by imitating some other author, however great.

Neither has there ever been any great poet or artist produced by training. But there are many writers who are not great authors, many rhymsters who are not poets, and many painters who are not artists; and while training will not make great men of them, it will help them to avoid doing that which is absolutely bad, and so may it not be with machine designing? If there are among you some who have a genius for it, what I shall have to say will do you no good, for genius needs no rules, no laws, no help, no training, and the sooner you let what I have to say pass from your minds, the better. Rules only hamper the man of genius; but for us, who either from choice or necessity work away at machine designing without the gift, cannot some simple ruling facts be determined and rules formulated or principles laid down by which we can determine what is really good, and what bad? One of the most important and one of the first things in the construction of a building is the foundation, and the laws which govern its construction can be stated in a breath, and ought to be understood by every one. Assuming the ground upon which a building is to be built to be of

uniform density, *the width* of the foundation should be in proportion to the load, the foundation should taper equally on each side, and the center of the foundation should be under the center of pressure. In other words, it is as fatal to success to have too much foundation under the light load as it is too little under a heavy one.

Cannot we analyze causes and effects, cost and requirements, so as to formulate some simple laws similar to the above by which we shall be able to determine what is a good and what a bad arrangement of machinery, foundation, framing or supports? A vast amount of work is expended to make machines true, and the machines, or a large majority of them, are expected to produce true work of some kind in turn. Then, if this be admitted, cannot the following law be established, that every machine should be so designed and constructed that when once made true it will so remain, regardless of wear and all external influences to which it is liable to be subjected? One tool maker says that it is right, and another that it cannot be done. No matter whether it can or cannot, is it not the thing wanted, and if so, is it not an object worth striving for? One tool maker says that all machine tools, engines, and machinery should set on solid stone foundations. Should they?

They do not always, for in substantial Philadelphia some machine tools used by machine builders stand upon second floors, or, perhaps, higher up. And of these machine tools none, or few at least, except those mounted upon a single pedestal, are free from detrimental torsion where the floor upon which they rest is distorted by unequal loading. But, to first consider those of such magnitude as to render it absolutely necessary to erect them—not rest them—on masonry, is due consideration always taken to arrange an unequal foundation to support the unequal loads?—and they cannot be expected to remain true if not. When one has the good fortune to have a machine to design of such extent that the masonry becomes the main part of it, what part of the glory does he give to the mason? Is the masonry part of it always satisfactory, and is not this resorting to the mason for a frame rather than a support adopted on smaller machines than is necessary? Is it necessary even in a planing machine of forty feet length of bed and a thirty foot table? Could not the bed be cast in three pieces, the center a rectangular box, 5 or 6 or 7 feet square, 20 feet long, with internal end flanges, ways planed on its upper surface, and ends squared off, a monster, perhaps, but if our civil engineers wanted such a casting for a bridge, they'd get it. Add to this central section two bevel pieces of half the length, and set the whole down through the floor where your masonry would have been and rest the whole on two cross walls, and you would have a structure that if once made true would remain so regardless of external influences. Cost? Yes; and so do Frodsham watches—more than "Waterbury."

It may be claimed, in fact, I have seen lathes resting on six and eight feet, engines on ten, and a planing machine on a dozen. Do they remain true? Sometimes they do, and many times they do not. Is the principle right? Not when it can be avoided; and when it cannot be avoided, the true principle of foundation building should be employed.... A strange example of depending on the stone foundation for not simply support, but to resist strain, may be found in the machines used for beveling the edges of boiler plate. Not so particularly strange that the first one might have, like Topsy, "growed," but strange because each builder copies the original. You will remember it, a complete machine set upon a stone foundation, to straighten and hold a plate, and another complete machine set down by the side of it and bolted to the same stone to plane off the edge; a lot of wasted material and a lot of wasted genius, it always seems to me. Going around Robin Hood's barn is the old comparison. Why not hook the tool carriage on the side of the clamping structure, and thus dispense with one of the frames altogether?

Many of the modern builders of what Chordal calls the hyphen Corliss engine claim to have made a great advance by putting a post under the center of the frame, but whether in acknowledgment that the frame would be likely to go down or the stonework come up I could never make out. What I should fear would be that the stone would come up and take the frame with it. Every brick mason knows better than to bed mortar under the center of a window sill; and this putting a prop under the center of an engine girder seems a parallel case. They say Mr. Corliss would have done the same thing if he had thought of it. I do not believe it. If Mr. Corliss had found his frames too weak, he would soon have found a way to make them stronger.

John Richards, once a resident of this city, and likely the best designer of wood-working machinery this country, if not the world, ever saw, pointed out in some of his letters the true form for constructing machine framing, and in a way that it had never been forced on my mind before. As dozens, yes, hundreds, of new designs have been brought out by machine tool makers and engine builders since John Richards made a convert of me, without any one else, so far as I know, having applied the principle in its broadest sense, I hope to present the case to you in a material form, in the hope that it may be more thoroughly appreciated.

The usual form of lathe and planer beds or frames is two side plates and a lot of cross girts; their duty is to guide the carriages or tables in straight lines and carry loads

resisting bending and torsional strains. If a designer desires to make his lathe frame stronger than the other fellows, he thinks, if he thinks at all, that he will put in more iron, rather than, as he ought to think, How shall I distribute the iron so it will do the most good?

In illustration of this peculiar way of doing things, which is not wholly confined to machine designers, I should like to relate a story, and as I had to carry the large end of the joke, it may do for me to tell it.

While occupying a prominent position, and yet compelled to carry my dinner, my wife thought the common dinner pail, with which you are probably familiar (by sight, of course), was not quite the thing for a professor (even by brevet) to be seen carrying through the streets. So she interviewed the tinsmith to see if he could not get up something a little more tony than the regulation fifty-cent sort. Oh, yes; he could do that very nicely. How much would the best one he could make cost? Well, if she could stand the racket, he could make one worth a dollar. She thought she could, and the pail was ordered, made, and delivered with pride. Perhaps you can guess the result. A facsimile of the original, only twice the size.

Now, this is a very fair illustration of the fallacy of making things stronger by simply adding iron. To illustrate what I think a much better way, I have had made these crude models (see Fig. 1), for the full force of which, as I said before, I am indebted to John Richards; and I would here add that the mechanic who has never learned anything from John Richards is either a very good or very poor one, or has never read what John Richards has written or heard what he has had to say.

Three models, as shown in Fig. 1, were exhibited; all were of the same general dimensions and containing the same amount of material. The one made on the box principle, *c*, proved to be fifty per cent. stiffer in a vertical direction than either a or *b*, from twenty to fifty times stiffer sidewise, and thirteen times more rigid against torsion than either of the others.

However strong a frame may be, its own weight and the weight of the work upon it tends to spring it unless evenly distributed, and to twist it unless evenly proportioned. For all small machines the single post obviates all trouble, but for machine tools of from twice to a half dozen times their own length the single post is not available. Four legs are used for machines up to ten feet or so, and above that legs various and then solid masonry. If the four legs were always set upon solid masonry, and leveled perfectly when set, no question could be raised against the usual arrangement, unless it be this: Ought they not to be set nearly one-fourth the way from the end of the bed? or to put it in another form: Will not the bed of an iron planing machine twelve feet in length be equally as well supported by four legs if each pair is set three feet from the ends—that is, six feet apart—as by six legs, two pairs at the ends and one in the center, and the pairs six feet apart? there being six feet of unsupported bed in either case, with this advantage in favor of the four over the six, settling of the foundation would not bend the bed.

It is not likely that one-half of the four-legged machine tools used in this country are resting upon stable foundations, nor that they ever will be; and while this is a fact, it must also remain a fact that they should be built so as to do their best on an unstable one. Any one of the thousand iron planing machines of the country, if put in good condition and set upon the ordinary wood floors, may be made to plane work winding in either direction by shifting a moving load of a few hundred pounds on the floor from one corner of the machine to the other, and the ways of the ordinary turning lathe may be more easily distorted still. Machine tool builders do not believe this, simply because they have not tried it. That is, I suppose this must be so, for the proof is so positive, and the remedy so simple, that it does not seem possible they can know the fact and overlook it. The remedy in the case of the planer is to rest the structure on the two housings at the rear end and on a pair of legs about one-fourth of the way back from the front, pivoted to the bed on a single bolt as near the top as possible.

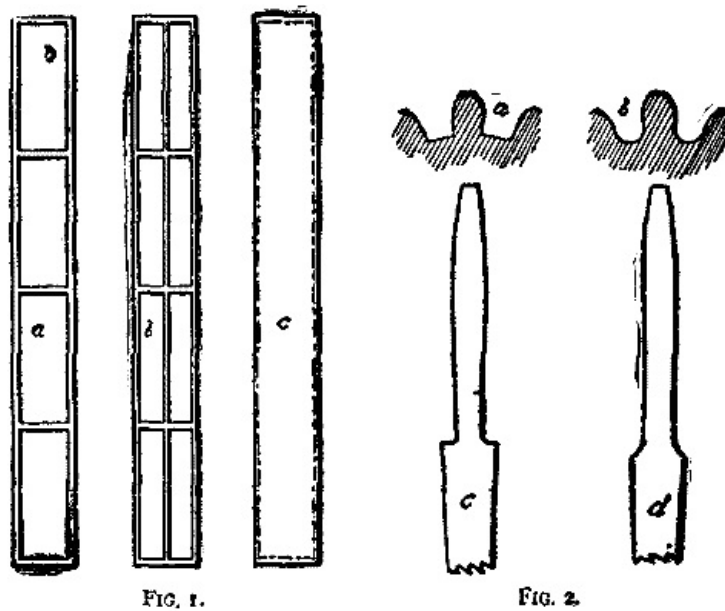

FIG. 1.

FIG. 2.

a, b, c Fig. 1, Mr. Sweet, which represented three forms of lathe and planer construction. The box form, *c*, proved to be fifty per cent. stronger in its vertical direction than either *a* or *b*, fifty times stronger sideways than *a* and twenty times stronger than *b*, and more than thirteen times stronger than either when subject to torsional strain.

a, Fig. 2, represents an ordinary pinion tooth, and *b* shows one of the same size strengthened by cutting put metal at the root; *c* and *d* were models showing the same width of teeth extended to six times the length, showing what would be their character if considered as springs.

A similar arrangement applies to the lathe and machine tools of that character—that is, machines of considerable length in proportion to their width, and with beds made sufficiently strong within themselves to resist all bending and torsional strains, fill the requirements so far as all except wear is concerned. That is, if the frames are once made true, they will remain so, regardless of all external influences that can be reasonably anticipated.

Among wood-working machines there are many that cannot be built on the single rectangular box plan—rested on three points of support. Fortunately, the requirements are not such as demand absolute straight and flat work, because in part from the fact that the material dealt with will not remain straight and flat even if once made so, and in the design of wood-working machinery it is of more importance to so design that one section or element shall remain true within itself, than that the various elements should remain true with one another.

The lathe, the planing machine, the drilling machine, and many others of the now standard machine tools will never be superseded, and will for a long time to come remain subjects of alteration and attempted improvement in every detail. The head stock of a lathe—the back gear in particular—is about as hard a thing to improve as the link motion of a locomotive. Some arrangement by which a single motion would change from fast to slow, and a substitute for the flanges on the pulleys, which are intended to keep the belt out of the gear, but never do, might be improvements. If the flanges were cast on the head stock itself, and stand still, rather than on the pulley, where they keep turning, the belt would keep out from between the gear for a certainty. One motion should fasten a foot stock, and as secure as it is possible to secure it, and a single motion free it so it could be moved from end to end of the bed. The reason any lathe takes more than a single motion is because of elasticity in the parts, imperfection in the planing, and from another cause, infinitely greater than the others, the swinging of the hold-down bolts.

Should not the propelling powers of a lathe slide be as near the point of greatest resistance as possible, as is the case in a Sellers lathe, and the guiding ways as close to the greatest resistance and propelling power as possible, and all other necessary guiding surfaces made to run as free as possible?

A common expression to be found among the description of new lathes is the one that says "the carriage has a long bearing on the ways." Long is a relative word, and the only place I have seen any long slides among the lathes in the market is in the advertisements. But if any one has the courage to make a long one, they will need something besides material to make a success of it. It needs only that the guiding side that should be long, and that must be as rigid as possible—nothing short of casting the apron in the same piece will be strong enough, because with a long,

elastic guide heavy work will spring it down and wear it away at the center, and then with light work it will ride at the ends, with a chattering cut as a consequence.

An almost endless and likely profitless discussion has been indulged in as to the proper way to guide a slide rest, and different opinions exist. It is a question that, so far as principle is concerned, there ought to be some way to settle which should not only govern the question in regard to the slide rest of a lathe, but all slides that work against a torsional resistance, as it may be called—that is, a resistance that does not directly oppose the propelling power. In other words, in a lathe the cutting point of the tool is not in line with the lead screw or rack, and a twisting strain has to be resisted by the slides, whereas in an upright drill the sliding sleeve is directly over and in line with the drill, and subject to no side strain.

Does not the foregoing statement that "the propelling power should be as near the resistance as possible, and the guide be as near in line with the two as possible," embody the true principle? Neither of the two methods in common use meets this requirement to its fullest extent. The two-V New England plan seems like sending two men to do what one can do much better alone; and the inconsistency of guiding by the back edge of a flat bed is prominently shown by considering what the result would be if carried to an extreme. If a slide such as is used on a twenty inch lathe were placed upon a bed or shears twenty feet wide, it would work badly, and that which is bad when carried to an extreme cannot well be less than half bad when carried half way.

The ease with which a cast iron bar can be sprung is many times overlooked. There is another peculiarity about cast iron, and likely other metals, which an exaggerated example renders more apparent than can be done by direct statement. Cast iron, when subject to a bending strain, acts like a stiff spring, but when subject to compression it dents like a plastic substance. What I mean is this: If some plastic substance, say a thick coating of mud in the street, be leveled off true, and a board be laid upon it, it will fit, but if two heavy weights be placed on the ends, the center will be thrown up in the air far away from the mud; so, too, will the same thing occur if a perfectly straight bar of cast iron be placed on a perfectly straight planer bed—the two will fit; but when the ends of the bar are bolted down, the center of the bar will be up to a surprising degree. And so with sliding surfaces when working on oil. If to any extent elastic, they will, when unequally loaded, settle through the oil where the load exists and spring away where it is not.

The tool post or tool holder that permits of a tool being raised or lowered and turned around after the tool is set, without any sacrifice of absolute stability, will be better than one in which either one of these features is sacrificed. Handiness becomes the more desirable as the machines are smaller, but handiness is not to be despised even in a large machine, except where solidity is sacrificed to obtain it.

The weak point in nearly all (and so nearly all that I feel pretty safe in saying all) small planing machines is their absolute weakness as regards their ability to resist torsional strain in the bed, and both torsional and bending strain in the table. Is it an uncommon thing to see the ways of a planer that has run any length of time cut? In fact, is it not a pretty difficult thing to find one that is not cut, and is this because they are overloaded? Not at all. Figure up at even fifty pounds to the square inch of wearing surface what any planer ought to carry, and you will find that it is not from overloading. Twist the bed upon the floor (and any of them will twist as easy as two basswood boards), and your table will rest the hardest on two corners. Strap, or bolt, or wedge a casting upon the table, or tighten up a piece between a pair of centers eight or ten inches above the table, and bend the table to an extent only equal to the thickness of the film of oil between the surface of the ways, and the large wearing surface is reduced to two wearing points. In designing it should always be kept in mind, or, in fact, it is found many times to be the correct thing to do, to consider the piece as a stiff spring, and the stiffer the better. The tooth of a gear wheel is a cast iron spring, and if only treated as would be a spring, many less would be broken. A point in evidence:

The pinions in a train of rolls, which compel the two or more rolls to travel in unison, are necessarily about as small at the pitch line as the rolls themselves; they are subject to considerable strain and a terrible hammering by back lash, and break discouragingly frequent, or do when made of cast iron, if not of very coarse pitch, that is, with very few teeth—eleven or twelve sometimes.

In a certain case it became desirable to increase the number of teeth, when it was found that the breakages occurred about as the square root of their number. When the form was changed by cutting out at the root in this form (Fig. 2), the breakage ceased.

a, Fig. 2, shows an ordinary gear tooth, and *b* the form as changed; *c* and *d* show the two forms of the same width, but increased to six times the length. If the two are considered as springs, it will be seen that *d* is much less likely to be broken by a blow

or strain.

The remedy for the flimsy bed is the box section; the remedy for the flimsy planer table is the deep box section, and with this advantage, that the upper edge can be made to shelve over above the reversing dogs to the full width between the housings.

The parabolic form of housing is elegant in appearance, but theoretically right only when of uniform cross section. In some of the counterfeit sort the designers seem to have seen the original Sellers, remembering the form just well enough to have got the curve wrong end up, and knowing nothing of the principle, have succeeded in building a housing that is absolutely weak and absolutely ugly, with just enough of the original left to show from where it was stolen. If the housing is constructed on the brace plan, should not the braces be straight, as in the old Bement, and the center line of strain pass through the center line of the brace? If the housing is to take the form of a curve, the section should be practically uniform, and the curve drawn by an artist. Many times housings are quite rigid enough in the direction of the travel of the table, but weak against side pressure. The hollow box section, with secure attachment to the bed and a deep cross beam at the top, are the remedies.

Raising and lowering cross heads, large and small, by two screws is a slow and laborious job, and slow when done by power. Counterweights just balancing the cross head, with metal straps rather than chains or ropes, large wheels with small anti-friction journals, and the cross head guarded by one post only, changes a slow to a quick arrangement, and a task to a comfort. Housings of the hollow box section furnish an excellent place for the counterweights.

The moving head, which is not expected to move while under pressure, seems to have settled into one form, and when hooked over a square ledge at the top, a pretty satisfactory form, too. But in other machines built in the form of planing machines, in which the head is traversed while cutting, as is the case with the profiling machine, the planer head form is not right. Both the propelling screw, or whatever gives the side motion, should be as low down as possible, as should also be the guide.

There is a principle underlying the Sellers method of driving a planer table that may be utilized in many ways. The endurance goes far beyond any man's original expectations, and the explanation, very likely, lies in the fact that the point of contact is always changing. To apply the same principle to a common worm gear it is only necessary to use a worm in a plain spur gear, with the teeth cut at an angle the wrong way, and set the worm shaft at an angle double the amount, rather than at 90°. Such a worm gear will, I fancy, outwear a dozen of the scientific sort. It would likely be found a convenience to have the head of a planing machine traverse by a handle or crank attached to itself, so it could be operated like the slide rest of a lathe, rather than as is now the case from the end of the cross head. The principle should be to have things convenient, even at an additional cost. Anything more than a single motion to lock the cross head to the housing or stanchions should not be countenanced in small planers at least. Many of the inferior machines show marked improvements over the better sorts, so far as handiness goes, while there is nothing to hinder the handy from being good and the good handy.

When we consider that since the post-drilling machine first made its appearance, there have been added Blasdell's quick return, the automatic feed, belt-driven spindles, back gears placed where they ought to be, with many minor improvements, it is not safe to assume that the end has been reached; and when we consider that as a piece of machine designing, considered in an artistic sense entirely, the Bement post drill is the finest the world ever saw (the Porter-Allen engine not excepted, which is saying a good deal), is it not strange that of all mechanical designs none other has taken on such outrageous forms as this?

One thing that would seem to be desirable, and that ordinary skill might devise, is some sort of snap clutch by which the main spindle could be stopped instantly by touching a trigger with the foot; many drills and accidents would be saved thereby. Of the many special devices I have seen for use on a drilling machine, one used by Mr. Lipe might be made of universal use. It is in the form of a bracket or knee adjustably attached to the post, which has in its upper surface a V into which round pieces of almost any size can be fastened, so that the drill will pass through it diametrically. It is not only useful in making holes through round bars, but straight through bosses and collars as well.

The radial drill has got so it points its nose in all directions but skyward, but whether in its best form is not certain. The handle of the belt shipper, in none that I have seen, follows around within reach of the drill as conveniently as one would like.

As the one suggestion I have to make in regard to the shaping machine best illustrates the subject of maintaining true wearing surfaces, I will leave it until I reach that part of my paper.

[1]

A lecture delivered before the Franklin Institute, Philadelphia, Monday, Jan. 30, 1888. From the journal of the Institute.

THE MECHANICS OF A LIQUID.

A liquid comes in handy sometimes in measuring the volume of a substance where the length, breadth, and thickness is difficult to get at. It is a very simple operation, only requiring the material to be plunged under water and measure the amount of displacement by giving close attention to the overflow. It is a process that was first brought into use in the days when jewelers and silversmiths were inclined to be a little dishonest and to make the most of their earnings out of the rule of their country. If we remember rightly, the voice of some one crying "Eureka" was heard about that time from somebody who had been taking a bath up in the country some two miles from home. Tradition would have us believe that the inventor left for the patent office long before his bathing exercises were half through with, and that he did the most of his traveling at a lively rate while on foot, but it is more reasonable to suppose that bath tubs were in use in those days, and that he noticed, as every good philosopher should, that his bathing solution was running over the edge of the tub as fast as his body sunk below the surface. Taking to the heels is something that we hear of even at this late day.

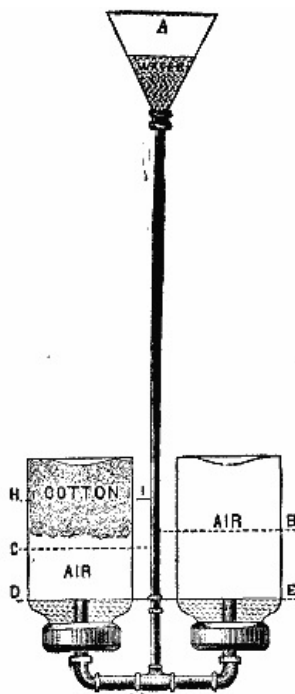

It was not many years ago that an inventor of a siphon noticed how water could be drawn up hill with a lamp wick, and the thought struck him that with a soaking arrangement of this kind in one leg of the siphon a flow of water could be obtained that would always be kept in motion. Without taking a second thought he dropped his work in the hay field, and ran all the way to London, a distance of twenty miles, to lay his scheme before a learned man of science. He must have felt like being carried home on a stretcher when he learned that a performance of this kind was a failure. Among the others who have given an exhibition of this kind we notice an observer who was more successful. Being an overseer in a cotton mill, he had only to run over to his dining room and secure two empty fruit jars and pipe them up, as shown. He had had trouble in measuring volume by the liquid process by having everything he attempted to measure get a thorough wetting, and there were many substances that were to be experimented upon that would not stand this part of the operation, such as fibers and a number of pulverized materials. One of the jars was packed in tight, nearly half full of cotton, and the other left entirely empty. The question now is to measure the volume of cotton without bringing any of the fibers in contact with the water. The liquid is poured into the tunnel in the upright tube under head enough to partially fill the jars when the overflow that stands on a level with the line, D E, is open to allow the air in each jar to adjust itself as the straight portions are wanted to work from. The overflow is then closed and head enough of water put on to compress the air in the empty jar down into half its volume. It may take a pipe long enough to reach up into the second story, but it need not be a large one, and pipes round a cotton mill are plentiful. In the jar containing cotton the water has not risen so high, there being not so much air to compress, and comes to rest on the line, C. Now we

have this simple condition to work from. If the water has risen so as to occupy half of the space that has been taken up by the amount of air in one jar, it must have done the same in the other, and if it could have been carried to twice the extent in volume would reach the bottom of the jar in the one containing nothing but air, and to the line, H I, in the jar containing cotton.

The fibers then must have had an amount of material substance about them to fill the remaining space entirely full, so that a particle of air could not be taken into account anywhere. The cotton has produced the same effect that a solid substance would do if it just filled the space shown above the line, H I, for the water has risen into half the space that is left below it. This enables an overseer to look into the material substance of textile fibers by bringing into use the elasticity of atmospheric air, reserving the liquid process for measuring volume to govern the amount of compressibility.—*Boston Journal of Commerce*.

VOLUTE DOUBLE DISTILLING CONDENSER.

This distiller and condenser which we illustrate has been designed, says *Engineering*, for the purpose of obtaining fresh water from sea water. It is very compact, and the various details in connection with it may be described as follows: Steam from the boiler is admitted into the evaporator through a reducing valve at a pressure of about 60 lb., and passing through the volute, B, evaporates the salt water contained in the chamber, C; the vapor thus generated passing through the pipe, D, into the volute condenser, E, where it is condensed. The fresh water thus obtained flows into the filter, from which it is pumped into suitable drinking tanks.

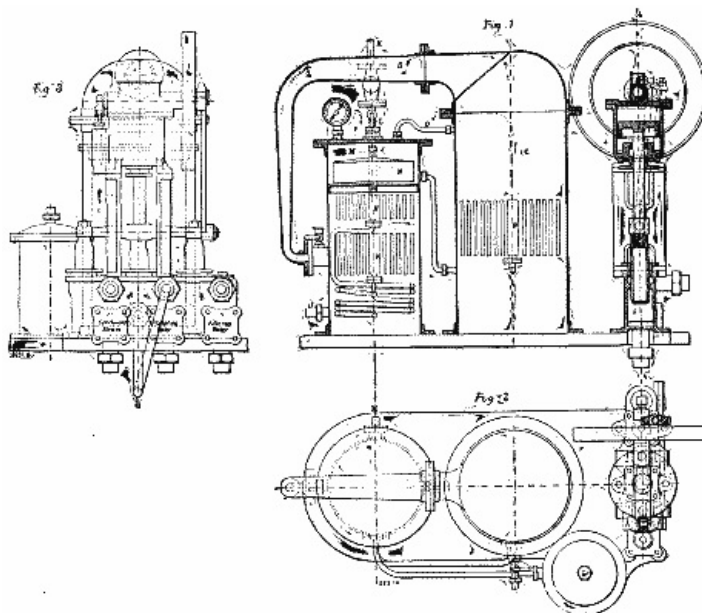

VOLUTE DOUBLE DISTILLING APPARATUS.

The steam from the boiler after passing through the volute, B, is conveyed by means of a pipe to the second volute, H, where it is condensed, and the water resulting is conveyed by means of a pump to the hot well or feed tank. The necessary condensing water enters at J and is discharged at K. The method of keeping the supply of salt water in the evaporator at a constant level is very efficient and ingenious. To the main circulating discharge pipe, a small pipe, L, is fitted, which is in communication with the chamber, M, and through this the circulating sea water runs back until it attains a working level in the evaporator, when a valve in the end of pipe, L, is closed by the action of the float, N, the regulation of admission being thus automatic and certain. The steam from the boiler can be regulated by means of a stop valve, and the pressure in the evaporator should not exceed 4 lb., while the pressure gauge is so arranged that the pressure in both condenser and evaporator is shown at the same time. A safety valve is fitted at the top of the condenser, and an automatic blow-off valve, P, is arranged to blow off when a certain density of brine has been attained in the evaporator. The "Esco" triple pump (Fig. 3), which has been specially manufactured for this purpose, has three suctions and deliveries, one for circulating water, the second for the condensed steam, and a third for the filtered drinking water, so that the latter is kept fresh and clean.

The condenser and pumps are manufactured by Ernest Scott & Co., Close Works, Newcastle on Tyne, and were shown by them at the late exhibition in their town.

IMPROVED CURRENT METER.

Paul Kotlarewsky, of St. Petersburg, has invented an instrument for measuring or ascertaining the velocity of water and air currents.

Upon the shaft or axis of the propeller wheel, or upon a shaft geared therewith, there is a hermetically closed tube or receptacle, D, which is placed at right angles with the shaft, and preferably so that its longitudinal axis shall intersect the axis of said shaft. In this tube or receptacle is placed a weight, such as a ball, which is free to roll or slide back and forth in the tube. The effect of this arrangement is, that as the shaft revolves, the weight will drop alternately toward opposite ends of the tube, and its stroke, as it brings up against either end, will be distinctly heard by the observer as well as felt by him if, as is usually the case, the apparatus when in use is held by him. By counting the strokes which occur during a given period of time, the number of revolutions during that period can readily be ascertained, and from that the velocity of the current to be measured can be computed in the usual way.

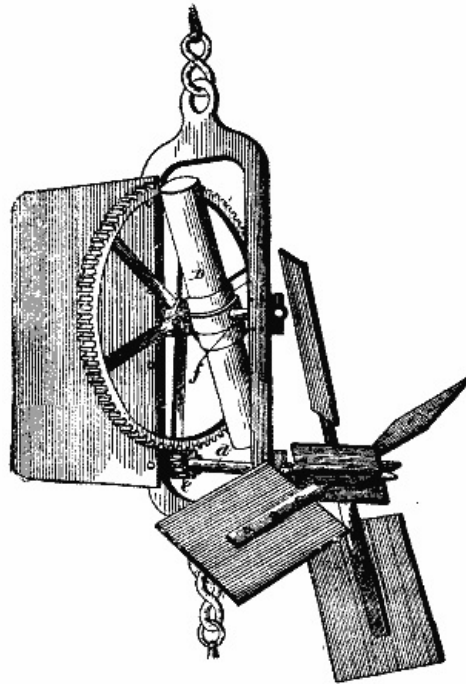

When the apparatus is submerged in water, by a rope held by the observer, it will at once adjust itself to the direction of the current. The force of the current, acting against the wings or blades of the propeller wheel, puts the latter in revolution, and the tube, D, will be carried around, and the sliding weight, according to the position of the tube, will drop toward and bring up against alternately opposite ends of said tube, making two strokes for every revolution of the shaft.

THE FLOWER INDUSTRY OF GRASSE.

A paper on this subject was read before the Chemists' Assistants' Association on March 8, by Mr. F.W. Warrick, and was listened to with much interest.

Mr. Warrick first apologized for presenting a paper on such a frivolous subject to men who had shown themselves such ardent advocates of the higher pharmacy, of the "ologies" in preference to the groceries, perfumeries, and other "eries." But if perfumery could not hope to take an elevated position in the *materiæ pharmaceuticæ*, it might be accorded a place as an adjunct, if only on the plea that those also serve who only stand and wait.

Mr. Warrick mentioned that his family had been connected with this industry for many years, and that for many of the facts in the paper he was indebted to a cousin who had had twenty years' practical experience in the South, and who was present that evening.

GRASSE.

The town of Grasse is perhaps more celebrated than any other for its connection with the perfume industry in a province which is itself well known to be its home.

This, the department of the Alpes Maritimes, forms the southeastern corner of France. Its most prominent geographical features are an elevated mountain range, a portion of the Alps, and a long seaboard washed by the Mediterranean—whence the name Alpes Maritimes.

The calcareous hills round Grasse and to the north of Nice are more or less bare, though they were at one time well wooded; the reforestation of these parts has, however, made of late great progress. Nearer the sea vegetation is less rare, and there many a promontory excites the just admiration of the visitor by its growth of olives, orange and lemon trees, and odoriferous shrubs. Who that has ever sojourned in this province can wonder that Goethe's Mignon should have ardently desired a return to these sunny regions?

Visitors on these shores on the first day of this year found Goethe's lines more poetical than true—

Where a wind ever soft from the blue heaven blows,
And the groves are of laurel, and myrtle, and rose;

for they gathered round their fires and coughed and groaned in chorus, and entertained each other with accounts of their ailments. But this was exceptional, and the climate of the Alpes Maritimes is on the whole as near perfection as anything earthly can be. This, however, is not due to its latitude, but rather to its happy protection from the north by its Alps and to its being bathed on the south by the warm Mediterranean and the soft breezes of an eastern wind (which evidently there bears a different reputation to that which it does with us). The mistral, or cold breeze from the hills, is indeed the only climatic enemy, if we except an occasional earthquake.

The town of Grasse itself is situated in the southern portion of the department, and enjoys its fair share of the advantages this situation affords. It is about ten miles from Cannes (Lord Brougham's creation), and, as the crow flies, twenty-five miles from Nice, though about forty miles by rail, for the line runs down to Cannes and thence along the shore to Nice.

Built on the side of a hill some 1,000 feet above the level of the sea, the town commands magnificent views over the surrounding country, especially in the direction of the sea, which is gloriously visible. An abundant stream, the Foux, issuing from the rocks just above the town, is the all productive genius of the place; it feeds a hundred fountains and as many factories, and then gives life to the neighboring fields and gardens.

The population of Grasse is about 12,000, and the flora of its environs represents almost all the botany of Europe. Among the splendid pasture lands, 7,000 feet above the sea, are fields of lavender, thyme, etc. From 7,000 to 6,000 feet there are forests of pine and other gymnosperms. From 6,000 to 4,000 feet firs and the beech are the most prominent trees. Between 4,000 and 2,000 feet we find our familiar friends the oak, the chestnut, cereals, maize, potatoes. Below this is the Mediterranean region. Here orange, lemon, fig, and olive trees, the vine, mulberry, etc., flourish in the open as well as any number of exotics, palms, aloes, cactuses, castor oil plants, etc. It is in this region that nature with lavish hand bestows her flowers, which, unlike their compeers in other lands, are not born to waste their fragrance on the desert air or to die "like the bubble on the fountain," but rather (to paraphrase George Eliot's lofty words) to die, and live again in fats and oils, made nobler by their presence.

The following are the plants put under contribution by the perfume factories of the district, viz., the orange tree, bitter and sweet, the lemon, eucalyptus, myrtle, bay laurel, cherry laurel, elder; the labiates; lavender, spike, thyme, etc.; the umbelliferous fennel and parsley, the composite wormwood and tarragon, and, more delicate than these, the rose, geranium, cassie, jasmin, jonquil, mignonette, and violet.

THE PERFUME FACTORY.

In the perfume factory everything is done by steam. Starting from the engine room at the bottom, the visitor next enters the receiving room, where early in the morning the chattering, patois-speaking natives come to deliver the flowers for the supply of which they have contracted. The next room is occupied with a number of steam-jacketed pans, a mill, and hydraulic presses. Next comes the still room, the stills in which are all heated by steam. In the "extract" department, which is next reached, are large tinned-copper drums, fitted with stirrers, revolving in opposite directions on vertical axes. Descending to the cellar—the coolest part of the building—we find the simple apparatus used in the process of enfleurage. The apparatus is of two kinds. The smaller is a frame fitted with a sheet of stout glass. A number of these, all of the same size, when placed one on the top of the other, form a tolerably air tight box. The larger is a frame fitted with wire netting, over which a piece of molleton is placed. The other rooms are used for bottling, labeling, etc.

The following are some of the details of the cultivation and extraction of perfumes as given in Mr. Warrick's paper:

ORANGE PERFUMES.

The orange tree is produced from the pip, which is sown in a sheltered uncovered bed. When the young plant is about 4 feet high, it is transplanted and allowed a year to gain strength in its new surroundings. It is then grafted with shoots from the Portugal or Bigaradier. It requires much care in the first few years, must be well manured, and during the summer well watered, and if at all exposed must have its stem covered up with straw in winter. It is not expected to yield a crop of flowers before the fourth year after transplantation. The flowering begins toward the end of April and lasts through May to the middle of June. The buds are picked when on the point of opening by women, boys, and girls, who make use of a tripod ladder to reach them. These villagers carry the fruits (or, rather, flowers) of their day's labor to a flower agent or commissionnaire, who weighs them, spreads them out in a cool place (the flowers, not the villagers), where they remain until 1 or 2 A.M.; he then puts them into sacks, and delivers them at the factory before the sun has risen. They are here taken in hand at once; on exceptional days as many as 160 tons being so treated in the whole province. After the following season, say end of June, the farmers prune their trees; these prunings are carted to the factory, where the leaves are separated and made use of.

During the autumn the ground round about the trees is well weeded, dug about, and manured. The old practice of planting violets under the orange trees is being abandoned. Later on in the year those blossoms which escaped extermination have developed into fruits. These, when destined for the production of the oil, are picked while green.

The orange trees produce a second crop of flowers in autumn, sometimes of sufficient importance to allow of their being taken to the factories, and always of sufficient importance to provide brides with the necessary bouquets.

Nature having been thus assisted to deliver these, her wonderful productions, the flowers, the leaves, and the fruits of the orange tree, at the factory, man has to do the rest. He does it in the following manner:

The flowers are spread out on the stone floor of the receiving room in a layer some 6 to 8 inches deep; they are taken in hand by young girls, who separate the sepals, which are discarded. Such of the petals as are destined for the production of orange flower water and neroli are put into a still through a large canvas chute, and are covered with water, which is measured by the filling of reservoirs on the same floor. The manhole of the still is then closed, and the contents are brought to boiling point by the passage of superheated steam through the coils of a surrounding worm. The water and oil pass over, are condensed, and fall into a Florentine receiver, where the oil floating on the surface remains in the flask, while the water escapes through the tube opening below. A piece of wood or cork is placed in the receiver to break up the steam flowing from the still; this gives time for the small globules of oil to cohere, while it breaks the force of the downward current, thus preventing any of the oil being carried away.

The first portions of the water coming from the still are put into large tinned copper vats, capable of holding some 500 gallons, and there stored, to be drawn off as occasion may require into glass carboys or tinned copper bottles. This water is an article of very large consumption in France; our English cooks have no idea to what an extent it is used by the *chefs* in the land of the "darned mounseer."

The oil is separated by means of a pipette, filtered, and bottled off. It forms the oil of neroli of commerce; 1,000 kilos. of the flowers yield 1 kilo. of oil. That obtained from the flowers of the Bigaradier, or bitter orange, is the finer and more expensive quality.

The delicate scent of orange flowers can be preserved quite unchanged by another and more gentle process, viz., that of maceration. It was noticed by some individual, whose name has not been handed down to us, that bodies of the nature of fat and oil are absorbers of the odor-imparting particles exhaled by plants. This property was seized upon by some other genius equally unknown to fame, who utilized it to transfer the odor of flowers to alcohol.

Where oil is used it is the very finest olive, produced by the trees in the neighborhood. This is put into copper vats holding about 50 gallons; 1 cwt. of flowers is added. After some hours the flowers are strained out by means of a large tin sieve. The oil is treated with another cwt. of flowers and still another, until sufficiently impregnated. It is then filtered through paper until it becomes quite bright; lastly it is put into tins, and is ready for exportation or for use in the production of extracts.

Where fat is employed as the macerating agent, the fat used is a properly adjusted mixture of lard and suet, both of which have been purified and refined during the winter months, and kept stored away in well closed tins.

One cwt. of the fat is melted in a steam-jacketed pan, and poured into a tinned copper vat capable of holding from 5 to 6 cwt. About 1 cwt. of orange flowers being added, these are well stirred in with a wooden spatula. After standing for a few hours, which time is not sufficient for solidification to take place, the contents are poured into shallow pans and heated to 60° C. The mixture thus rendered more fluid is poured on to a tin sieve; the fat passes through, the flowers remain behind. These naturally retain a large amount of macerating liquor. To save this they are packed into strong canvas bags and subjected to pressure between the plates of a powerful hydraulic press. The fat squeezed out is accompanied by the moisture of the flowers, from which it is separated by skimming. Being returned to the original vat, our macerating medium receives another complement of flowers to rob of their scent, and yet others, until the strength of the pomade desired is reached. The fat is then remelted, decanted, and poured into tins or glass jars.

To make the extrait, the pomade is beaten up with alcohol in a special air tight mixing machine holding some 12 gallons, stirrers moved by steam power agitating the pomade in opposite directions. After some hours' agitation a creamy liquid is produced, which, after resting, separates, the alcohol now containing the perfume. By passing the alcohol through tubes surrounded by iced water, the greater part of the dissolved fat is removed.

These are the processes applied to the flowers. The leaves are distilled only for the oil of petit grain. This name was given to the oil because it was formerly obtained from miniature orange fruits. From 1,000 kilos. of leaves 2 kilos. of oil are obtained.

The oil obtained from the fruit of the orange, like that of the lemon, is extracted at Grasse by rolling the orange over the pricks of an *ecueille*, an instrument with a hollow handle, into which the oil flows. The oil is sometimes taken up by a sponge. Where the oil is produced in larger quantities, as at Messina, more elaborate apparatus is employed. A less fragrant oil is obtained by distilling the raspings of the rind.

THE EUCALYPTUS, MYRTLE, ETC.

Of later introduction than the trees of the orange family is the Eucalyptus globulus, which, not being able to compete with the former in the variety of nasal titillations it gives rise to, probably consoles itself with coming off the distinct victor in the department of power and penetration. The leaves and twigs of this tree are distilled for oil. This oil is in large demand on the Continent, the fact of there being no other species than the globulus in the neighborhood being a guarantee of the uniformity of the product.

Whereas the eucalyptus is but a newcomer in these regions, another member of the same family, the common myrtle, can date its introduction many centuries back. An oil is distilled from its leaves, and also a water.

Associated with the myrtle we find the leaves of the bay laurel, forming the victorious wreaths of the ancients. The oil produced is the oil of bay laurel, oil of sweet bay. This must not be confounded with the oil of bays of the West Indies, the produce of the *Myrcia acris*; nor yet with the cherry laurel, a member of yet another family, the leaves of which are sometimes substituted for those of the sweet bay. The leaves of this plant yield the cherry laurel water of the B.P. It can hardly be said to be an article of perfumery. It also yields an oil.

Another water known to the British Pharmacopoeia is that produced from the flowers of the elder, which flourishes round about Grasse.

The rue also grows wild in these parts, and is distilled.

THE LABIATES.

The family which overshadows all others in the quantity of essential oils which it puts at the disposal of the Grassois and their neighbors is that of the Labiatæ. Foremost among these we have the lavender, spike, thyme, and rosemary. These are all of a vigorous and hardy nature and require no cultivation. The tops of these plants are generally distilled *in situ*, under contract with the Grasse manufacturer, by the villagers in the immediate vicinity. The higher the altitude at which these grow, the more esteemed the oil. The finest oil of lavender is produced by distilling the flowers only. About 100 tons of lavender, 25 of spike, 40 of thyme, and 20 of rosemary are sent out from Grasse every year.

Among the less abundant labiates of these parts is the melissa, which yields, however, a very fragrant oil.

In the same family we have the sage and the sweet or common basil, also giving up their essential oils on distillation.

THE UMBELLIFERS.

Whereas the flowers of the labiate family are treated by the distillers as favorites are by the gods, and are cut off in their youth, those of the Umbelliferæ are allowed to mature and develop into the oil-yielding fruits. Its representatives, the fennel and parsley, grow wild round about the town, and are laid under contribution by the manufacturers.

The Composites are represented by the wormwood and tarragon (*Estragon*).

THE GERANIUM.

Oil of geranium is produced from the rose or oak-leaved geranium, cuttings of which are planted in well sheltered beds in October. During the winter they are covered over with straw matting. In April they are taken up, and planted in rows in fields or upon easily irrigated terraces. Of water they require *quantum sufficit*; of nature's other gift, which cheers and not inebriates—the glorious sunshine—they cannot have too much. They soon grow into bushes three or four feet high. At Nice they generally flower at the end of August. At Grasse and cooler places they flower about the end of October. The whole flowering plant is put into the still.

THE ROSE.

Allied to the oil of geranium in odor are the products of the rose. The Rose de Provence is the variety cultivated. It is grown on gentle slopes facing the southeast. Young shoots are taken from a five-year-old tree, and are planted in ground which has been well broken up to a depth of three or four feet, in rows like vines. When the young plant begins to branch out, the top of it is cut off about a foot from the ground. During the first year the farmer picks off the buds that appear, in order that the whole attention of the plant may be taken up in developing its system. In the fourth or fifth year the tree is in its full yielding condition. The flowering begins about mid-April, and lasts through May to early June. On some days as many as 150 tons of roses are gathered in the province of the Alpes Maritimes.

The buds on the point of opening are picked in the early morning. Scott says they are "sweetest washed with morning dew." The purchaser may think otherwise where the dew has to be paid for.

The flowering season over, the trees are allowed to run wild. In January they are pruned, and the branches left are entwined from tree to tree all along the line, and form impenetrable fences.

A rose tree will live to a good age, but does not yield much after its seventh year. At that period it is dug up and burned, and corn, potatoes, or some other crop is grown on the land for twelve months or more.

In the factory the petals are separated from the calyx, and are distilled with water for the production of rose water and the otto. For the production of the huile and pomade they are treated by maceration. They are finished off, however, by the process of enflourage, in which the frames before alluded to are made use of. The fat, or pomade, is spread on to the glass on both sides. The blossoms are then lightly strewn on to the upper surface. A number of trays so filled are placed one on the top of the other to a convenient height, forming a tolerably air tight box. The next day the old flowers are removed, and fresh ones are substituted for them. This is repeated until the fat is sufficiently impregnated. From time to time the surface of the absorbent is renewed by serrating it with a comb-like instrument. This, of course, is necessary in order to give the hungry, non-saturated lower layers a chance of doing their duty.

Where oil is the absorbent, the wired frames are used in connection with cloths. The cloth acts as the holder of the oil, and the flowers are spread upon it, and the process is conducted in the same way as with the frames with glass.

From the pomade the extrait de rose is made in the same way as the orange extrait.

CASSIE.

The stronger, though less delicate, cassie is grown from seeds, which are contained in pods which betray the connection of this plant with the leguminous family. After being steeped in water they are sown in a warm and well sheltered spot. When two feet high the young plant is grafted and transplanted to the open ground—ground well exposed to the sun and sheltered from the cold winds. It flourishes best in the neighborhood of Grasse and Cannes. The season of flowering is from October to January or February, according to the presence or absence of frost. The flowers are gathered twice a week in the daytime, and are brought to the factories in the

evening. They are here subjected to maceration.

JONQUIL.

A plant of humbler growth is the jonquil. The bulbs of this are set out in rows. The flowers put in an appearance about the end of March, four or five on each stem. Each flower as it blooms is picked off at the calyx. They are treated by maceration and enflourage, chiefly the latter. The harvesting period of the jonquil is of very short duration, and it often takes two seasons for the perfumer to finish off his pomades of extra strength. The crop is also very uncertain.

JASMIN.

A more reliable crop is that of the jasmin. This plant is reared from cuttings of the wild jasmin, which are put in the earth in rows with trenches between. Level ground is chosen; if hillside only is available, this is formed into a series of terraces. When strong enough, the young stem is grafted with shoots of the *Jasminum grandiflorum*. The first year it is allowed to run wild, the second it is trained by means of rods, canes and other appliances. At the approach of winter the plants are banked up with earth to half their height. The exposed parts then die off. When the last frost of winter is gone the earth is removed, and what remains of the shrub is trimmed and tidied up for the coming season. It grows to four or five feet. Support is given by means of horizontal and upright poles, which join the plants of one row into a hedge-like structure. Water is provided by means of the ditches already mentioned. When not used for this purpose, the trenches allow of the passage of women and children to gather the flowers. These begin to appear in sufficient quantity to repay collecting about the middle of July. The jasmin is collected as soon as possible after it blooms. This occurs in the evening, and up to about August 15, early enough for the blossoms to be gathered the same day. They are delivered at the factories at once, where they are put on to the chassis immediately; the work on them continuing very often till long after midnight. Later on in the year they are gathered in the early morning directly the dew is off. The farmer is up betimes, and as soon as he sees the blossoms are dry he sounds a bugle (made from a sea shell) to announce the fact to those engaged to pick for him.

TUBEROSE.

The tuberose is planted in rows in a similar way to the jasmin. The stems thrown up by the bulbs bear ten or twelve flowers. Each flower as it blooms is picked off. The harvesting for the factories takes place from about the first week in July to the middle of October. There is an abundant yield, indeed, after this, but it is only of service to the florist, the valued scent not being present in sufficient quantity. The flowers are worked up at the factory directly they arrive by the enflourage process.

MIGNONETTE.

The *reseda*, or mignonette, is planted from seed, as here in England. The flowering tops are used to produce the huile or pomade.

VIOLETS.

Last in order and least in size comes the violet. For "the flower of sweetest smell is shy and lowly," and has taken a modest place in the paper.

Violets are planted out in October or April. October is preferred, as it is the rainy season; nor are the young plants then exposed to the heat of the sun or to the drought, as they would be if starting life in April.

The best place for them is in olive or orange groves, where they are protected from the too powerful rays of the sun in summer and from the extreme cold in winter. Specks of violets appear during November. By December the green is quite overshadowed, and the whole plantation appears of one glorious hue. For the leaves, having developed sufficiently for the maintenance of the plant, rest on their oars, and seem to take a silent pleasure in seeing the young buds they have protected shoot past them and blossom in the open.

The flowers are picked twice a week; they lose both color and flavor if they are allowed to remain too long upon the plant. They are gathered in the morning, and delivered at the factories by the commissionnaires or agents in the afternoon, when they are taken in hand at once.

The products yielded by this flower are prized before all others in the realms of perfumery, and cannot be improved; for, as one great authority on all matters has said: "To throw a perfume on the violet ... were wasteful and ridiculous excess."

HOW TO MAKE PHOTO. PRINTING PLATES.

The drawing intended for reproduction is pinned on a board and placed squarely before a copying camera in a good, even light. The lens used for this purpose must be capable of giving a perfectly sharp picture right up to the edges, and must be of the class called rectilinear, *i.e.*, giving straight lines. The picture is then accurately focused and brought to the required size. A plate is prepared in the dark room by the collodion process, which is then exposed in the camera for the proper time and developed in the ordinary way. After development, the plate is fixed and strongly intensified, in order to render the white portions of the drawings as opaque as possible. On looking through a properly treated negative of this kind, it will be seen that the parts representing the lines and black portions of the drawing are clear glass, and the whites representing the paper a dense black.

The negative, after drying, is ready for the next operation, *i.e.*, printing upon zinc. This is done in several ways. One method will, however, be sufficient for the purpose here. I obtain a piece of the bichromatized gelatine paper previously mentioned, and place it on the face of the negative in a printing frame. This is exposed to sunlight (if there is any) or daylight for a period varying from five to thirty minutes, according to the strength of the light. This exposed piece of paper is then covered all over with a thin coating of printing ink, and wetted in a bath of cold water. In a few minutes the ink leaves the white or protected parts of the paper, remaining only on the lines where the light has passed through the negative and affected the gelatine. We now have a transcript of the drawing in printing ink, on a paper which, as soon as dry, is ready for laying down on a piece of perfectly clean zinc, and passing through a press. The effect and purpose of passing this cleaned sheet of zinc through the press in contact with the picture on the gelatine paper is this: Owing to the stronger attraction of the greasy ink for the clean metal than for the gelatine, it leaves its original support, and attaches itself strongly to the zinc, giving a beautifully sharp and clean impression of our original drawing in greasy ink on the surface of the zinc. The zinc plate is next damped and carefully rolled up with a roller charged with more printing ink, and the image is thus made strong enough to resist the first etching. This etching is done in a shallow bath, which is so arranged that it can be rocked to and fro. For the first etching, very weak solution of nitric acid and water is used. The plate is placed with this acid solution in the bath, and steadily rocked for five or ten minutes. The plate is then taken out, washed, and again inked; then it is dusted over with powdered resin, which sticks to the ink on the plate. After this the plate is heated until the ink and resin on the lines melt together and form a strong acid-resisting varnish over all the work. The plate is again put into the acid etching bath and further etched. These operations are repeated five or six times, until the zinc of the unprotected or white part of the picture is etched deep enough to allow the lines to be printed clean in a press, like ordinary type or an engraved wood block. I ought perhaps to explain that between each etching the plate is thoroughly inked, and that this ink is melted down the sides of the line, so as to protect the sides as well as the top from the action of the acid; were this neglected, the acid would soon eat out the lines from below. The greatest skill and care is, therefore, necessary in this work, especially so in the case of some of the exquisitely fine blocks which are etched for some art publications.

There are many details which are necessary to successful etching, but those now given will be sufficient to convey to you generally the method of making the zinc plate for the typographic block. After etching there only remains the trimming of the zinc, a little touching up, and mounting it on a block of mahogany or cherry of exact thickness to render it type high, and it is now ready for insertion with type in the printer's form. From a properly etched plate hundreds of thousands of prints may be obtained, or it may be electrotyped or stereotyped and multiplied indefinitely.—*G.S. Waterlow, Brit. Jour. Photo.*

ANALYSIS OF A HAND FIRE GRENADE.

By CHAS. CATLETT and R.C. PRICE.

The analyses of several of these "fire extinguishers" have been published, showing that they are composed essentially of an aqueous solution of one or more of the following bodies; sodium, potassium, ammonium, and calcium chlorides and sulphates, and in small amount borax and sodium acetate; while their power of extinguishing fire is but three or fourfold that of water.

One of these grenades of a popular brand of which I have not found an analysis was examined by Mr. Catlett with the following results: The blue corked flask was so open as to show that it contained no gas under pressure, and upon warming its contents, but 4 or 5 cubic inches of a gas were given off. The grenade contained

about 600 c.c. of a neutral solution, which gave on analysis:

		In 1000 c.c. In the Flask.	
		Grammes.	Grains.
Calcium	chloride ¹	92.50	850.8
Magnesium	"	18.71	173.2
Sodium	"	22.20	206.9
Potassium	"	1.14	10.6
		-----	-----
		134.55	1241.5

¹Trace of bromide.

As this mixture of substances naturally suggested the composition of the "mother liquors" from salt brines, Mr. Price made an analysis of such a sample of "bittern" from the Snow Hill furnace, Kanawha Co., W.Va., obtaining the following composition:

		In 1000 c.c. In the Flask.	
		Grammes.	Grains.
Calcium	chloride ¹	299.70	925.8
Magnesium	"	56.93	175.7
Strontium	"	1.47	4.5
Sodium	"	20.16	62.2
Potassium	"	5.13	15.8
		-----	-----
		383.39	1184.0

¹Trace of bromide.

There is of course some variation in the bittern obtained from different brines, but it appears of interest to call attention to this correspondence in composition, as indicating that the liquid for filling such grenades is obtained by adding two volumes of water to one of the "bittern." The latter statement is fairly proved by the presence of the bromine, and certainly from an economical standpoint such should be its method of manufacture.—*Amer. Chem. Jour.*

MOLECULAR WEIGHTS.

A new and most valuable method of determining the molecular weights of non-volatile as well as volatile substances has just been brought into prominence by Prof. Victor Meyer (*Berichte*, 1888, No. 3). The method itself was discovered by M. Raoult, and finally perfected by him in 1886, but up to the present has been but little utilized by chemists. It will be remembered that Prof. Meyer has recently discovered two isomeric series of derivatives of benzil, differing only in the position of the various groups in space. If each couple of isomers possess the same molecular weight, a certain modification of the new Van't Hoff-Wislicenus theory as to the position of atoms in space is rendered necessary; but if the two are polymers, one having a molecular weight n times that of the other, then the theory in its present form will still hold. Hence it was imperative to determine without doubt the molecular weight of some two typical isomers. But the compounds in question are not volatile, so that vapor density determinations were out of the question. In this difficulty Prof. Meyer has tested the discovery of M. Raoult upon a number of compounds of known molecular weights, and found it perfectly reliable and easy of application. The method depends upon the lowering of the solidifying point of a solvent, such as water, benzine, or glacial acetic acid, by the introduction of a given weight of the substance whose molecular weight is to be determined. The amount by which the solidifying point is lowered is connected with the molecular weight, M , by the following extremely simple formula: $M = T \times (P / C)$; where C represents the amount by which the point of congelation is lowered, P the weight of anhydrous substance dissolved in 100 grammes of the solvent, and T a constant for the same solvent readily determined from volatile substances whose molecular weights are well known. On applying this law to the case of two isomeric benzil derivatives, the molecular weights were found, as expected, to be identical, and not multiples; hence Prof. Meyer is perfectly justified in introducing the necessary modification in the "position in space" theory. Now that this generalization of Raoult is placed upon a secure basis, it takes its well merited rank along with that of Dulong and Petit as a most valuable means of checking molecular weights, especially in determining which of two or more possible values expresses the truth.—*Nature*.

THE DIRECT OPTICAL PROJECTION OF ELECTRO-DYNAMIC LINES OF FORCE AND OTHER ELECTRO-DYNAMIC PHENOMENA.¹

By Prof. J.W. MOORE.

II. LOOPS.

If the wire, with its lines of force, be bent into the form of a vertical circle $1\frac{1}{8}$ in. in diameter, and fixed in a glass plate, some of the lines of force will be seen parallel to the axis of the circle. If the loop is horizontal, the lines become points.

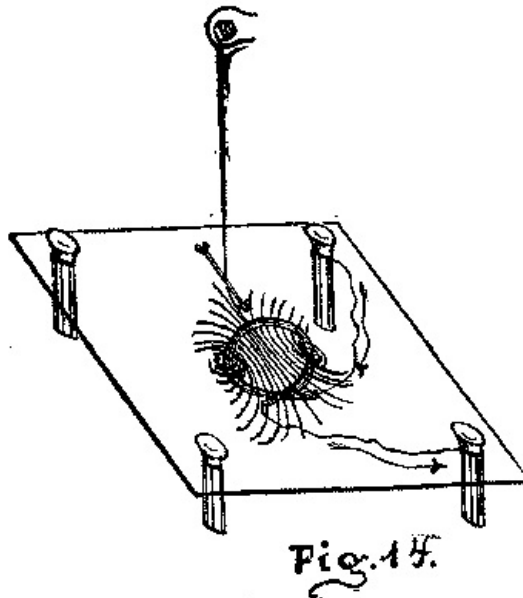

Fig. 14.

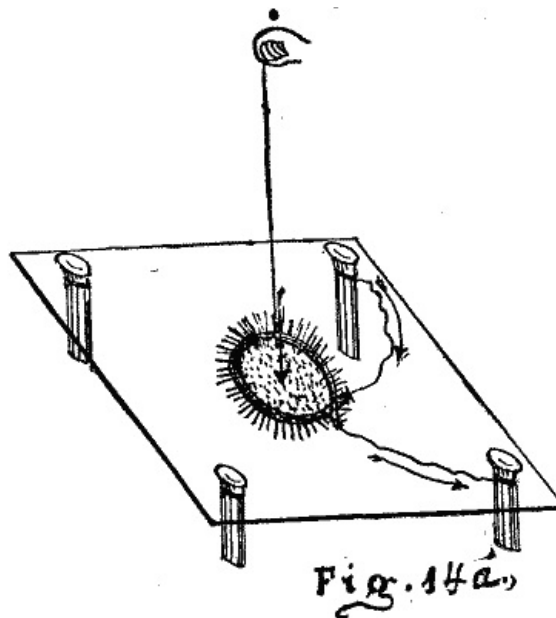

Fig. 14a.

FIELDS OF LOOPS AND MAGNETS.

Place now a vertical loop opposite to the pole of a short bar magnet cemented to the glass plate with the N pole facing it. If the current passes in one direction the field will be as represented by Fig. 14*b*; if it is reversed by the commutator, Fig. 14*c* is an image of the spectrum. Applying Faraday's second principle, it appears that attraction results in the first case, and repulsion in the second. The usual method of stating the fact is, that if you face the loop and the current circulates from left over to right, the N end of the needle will be drawn into the loop.

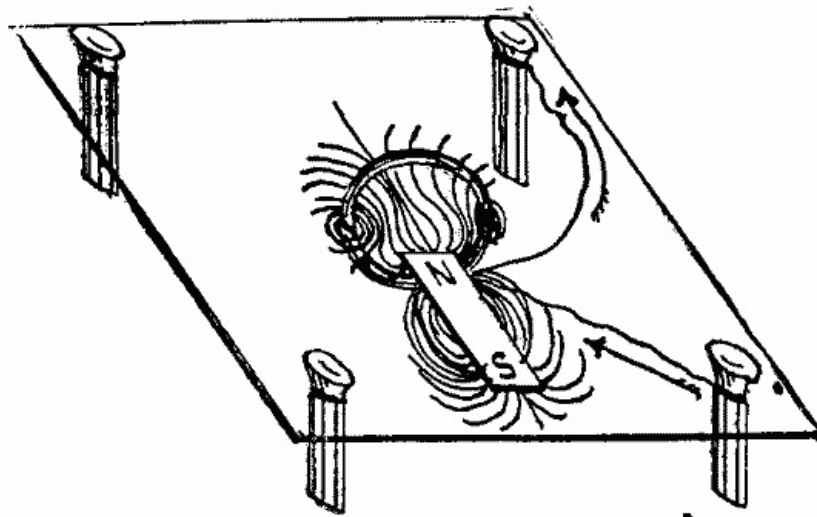

Fig. 14b.

Fig. 14b.

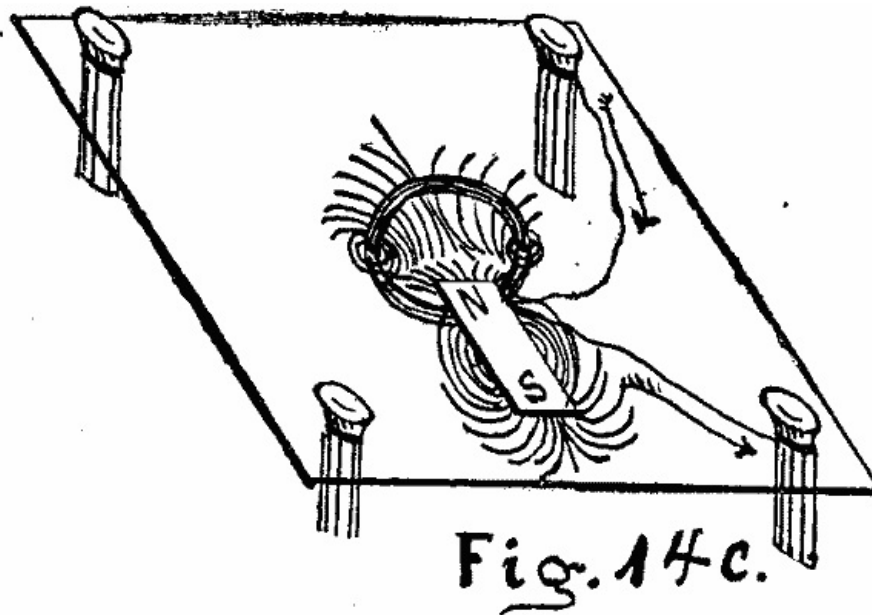

Fig. 14c.

Fig. 14c.

It thus becomes evident that the loop is equivalent to a flat steel plate, one surface of which is N and the other S. Facing the loop if the current is right handed, the S side is toward you.

TO SHOW THE ACTUAL ATTRACTION AND REPULSION OF A MAGNET BY A "MAGNETIC SHELL."

Produce the field as before (Fig. 14), carry a suspended magnetic needle over the field. It will tend to place itself parallel to the lines of force, with the N pole in such a position that, if the current passes clockwise as you look upon the plane of the loop, it will be drawn into the loop. Reversing the position of the needle or of current will show repulsion.

Clerk Maxwell's method of stating the fact is that "every portion of the circuit is acted on by a force urging it across the lines of magnetic induction, so as to include a greater number of these lines within the embrace of the circuit."²

If the horizontal loop is used (Fig. 14a), the needle tries to assume a vertical position, with the N or S end down, according to the direction of the current.

If it is desired to show that if the magnet is fixed and the loop free, the loop will be attracted or repelled, a special support is needed.

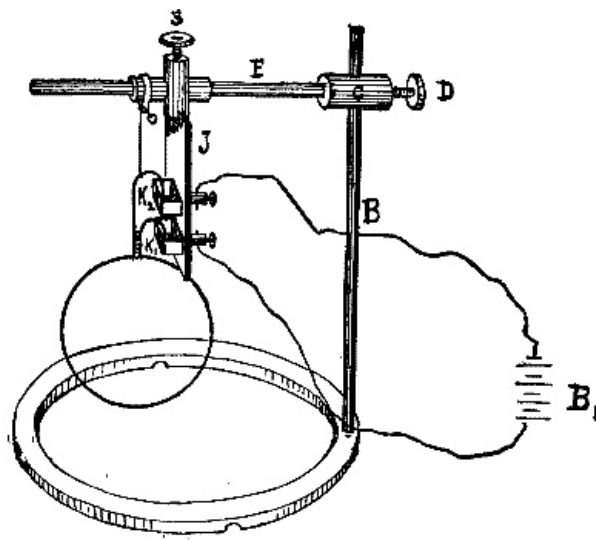

Fig. 15.

Fig. 15

A strip (Fig. 15) of brass, J, having two iron mercury cups, K_1 K_2 , screwed near the ends, one insulated from the strip, is fastened upon the horizontal arm of the ring support, Fig. 9, already described. The cups may be given a slight vertical motion for accurate adjustment. Small conductors (Figs. 16, 17, 18), which are circles, rectangles, solenoids, etc., may be suspended from the top of the plate by unspun silk, with the ends dipping into the mercury. The apparatus is therefore an Ampere's stand, with the weight of the movable circuit supported by silk and with means of adjusting the contacts. The rectangles or circles are about two inches in their extreme dimension. Horizontal and vertical astatic system are also used—Figs. 18, 18a. The apparatus may be used with either the horizontal or vertical lantern.

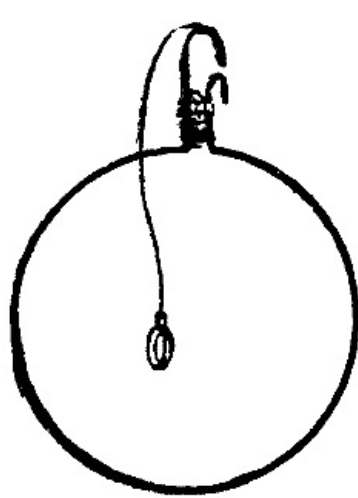

Fig. 16.

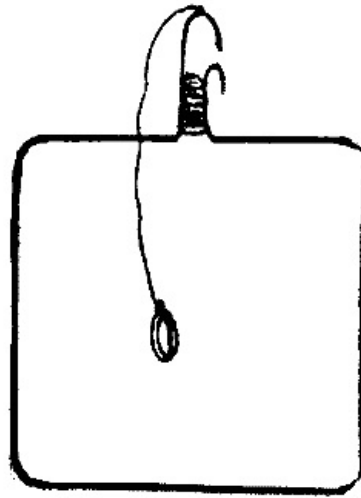

Fig. 17.

Fig. 16. Fig. 17.

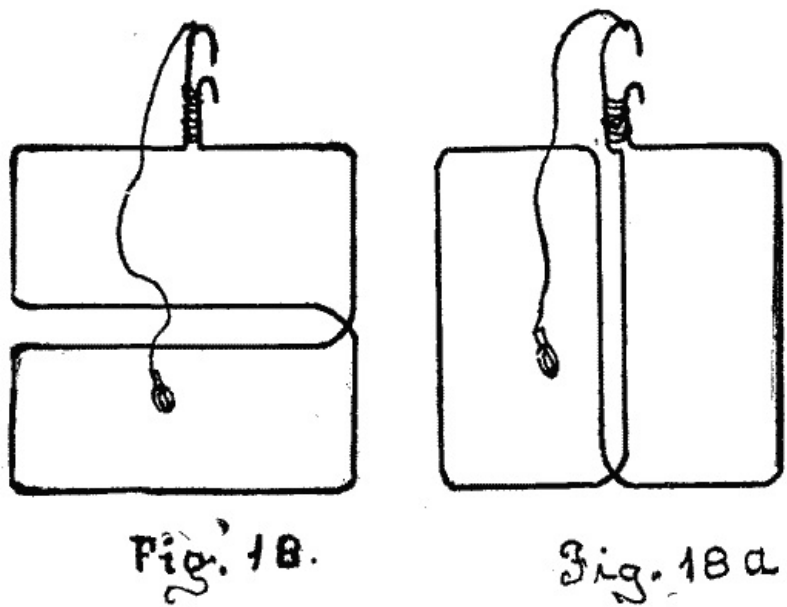

Fig. 18. Fig. 18a.

If the rectangle or circle is suspended and a magnet brought near it when the current passes, the loop will be attracted or repelled, as the law requires. The experiments usually performed with De la Rive's floating battery may be exhibited.

The great similarity between the loop and the magnet may be shown by comparing the fields above (Figs. 14*b*, 14*c*) with the actual fields of two bar magnets, Figs. 19, 19*a*.

It will be noticed that the lines in Fig. 19, where unlike poles are opposite, are gathered together as in Fig. 14*b*,—where the N end of the magnet faces the S side of the magnetic shell; and that in 19*a*, where two norths face, the line of repulsion has the same general character as in 14*c*, in which the N end of the magnet faces the N side of the shell.

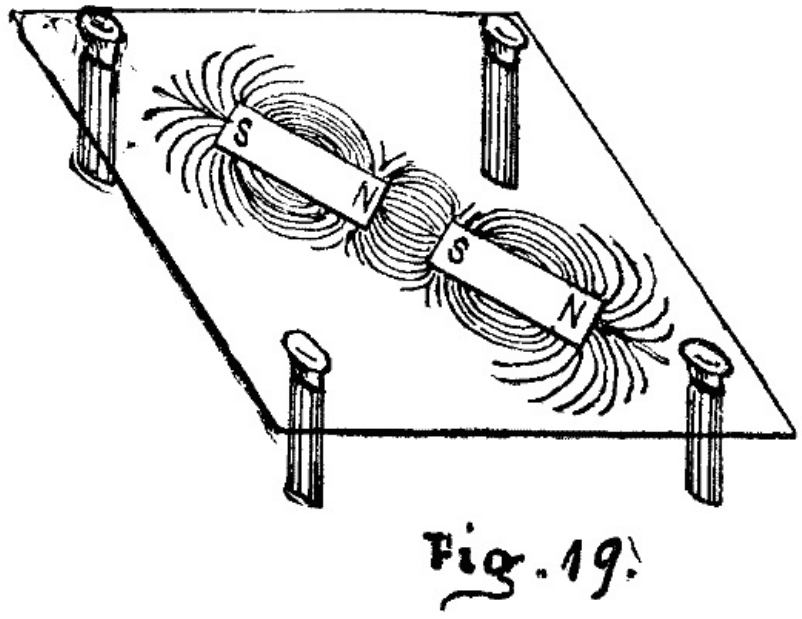

Fig. 19.

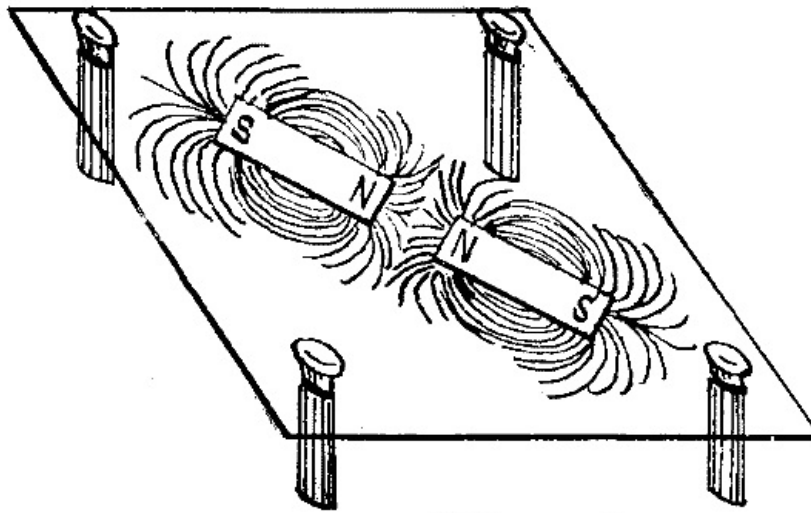

Fig. 19a.

Fig. 19a.

Instead of placing the magnet perpendicular to the plane of the loop, it may be placed parallel to its plane. Fig. 14*d* shows the magnet and loop both vertical.

The field shows that the magnet will be rotated, and will finally take for stable equilibrium an axial position, with the N end pointing as determined by the rule already given.

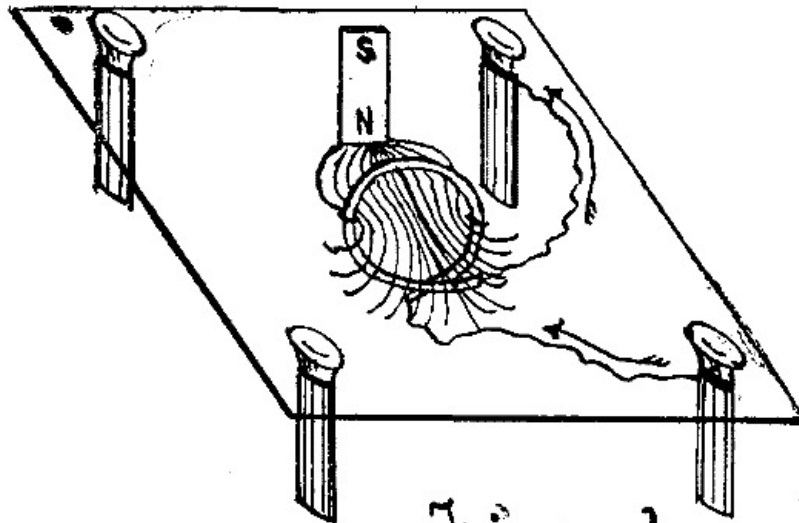

Fig: 14 d.

Fig. 14*d*.

If two loops are placed with their axes in the same straight line as follows, Figs. 14*f*, 14*g*, a reproduction of Figs. 14*b* and 14*c* will become evident.

It is obvious from these spectra that the two loops attract or repel each other according to the direction of the current, which fact may be shown by bringing a loop near to another loop suspended from the ring stand, Fig. 9, or by using the ordinary apparatus for that purpose—De la Rive's battery and Ampere's stand.

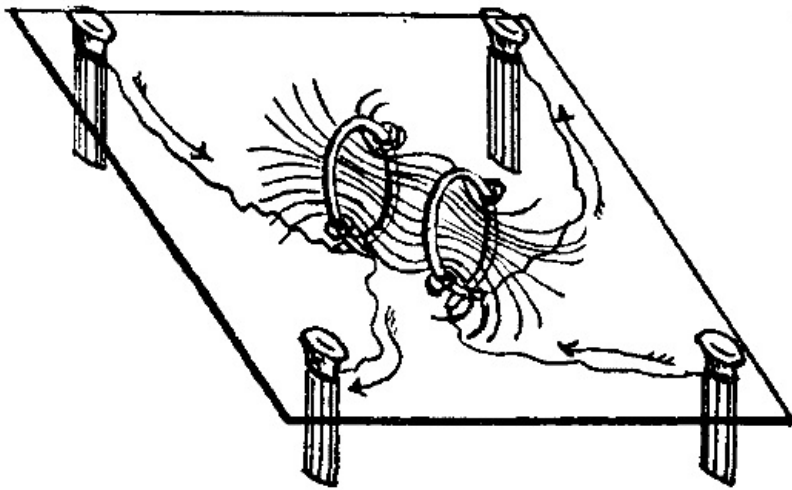

Fig. 14f

Fig. 14f.

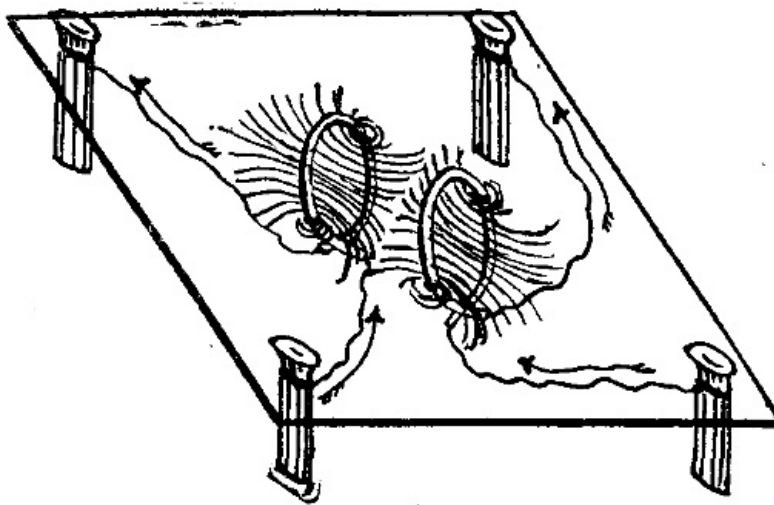

Fig. 14g.

Fig. 14g.

If two loops are placed in the same vertical plane, as in Figs. 14*h* and 14*i*, there will be attraction or repulsion, according to the direction of the adjacent currents. The fields become the same as Figs. 8 and 8*a*, as may be seen by comparing them with those figures.

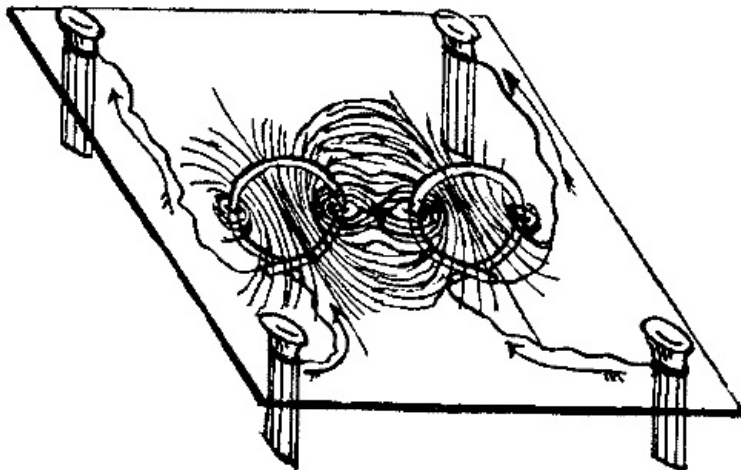

Fig. 14h.

Fig. 14h.

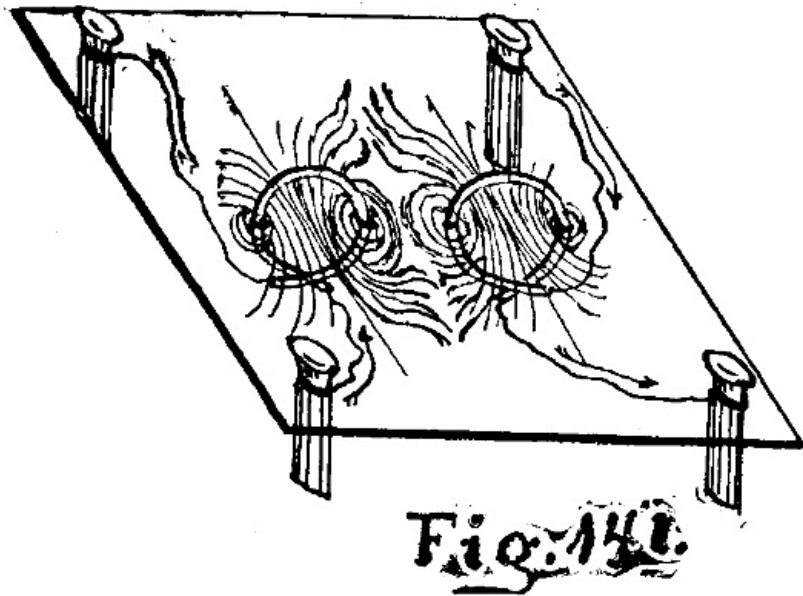

Fig. 14i.

Having thus demonstrated the practical identity of a loop and a magnet, we proceed to examine the effects produced by loops on straight wires.

If the loop is placed with a straight wire in its plane along one edge, there will be attraction or repulsion, according to the direction of the two currents, Figs. 20 and 20a, which are obviously the same as Figs. 8 and 8a.

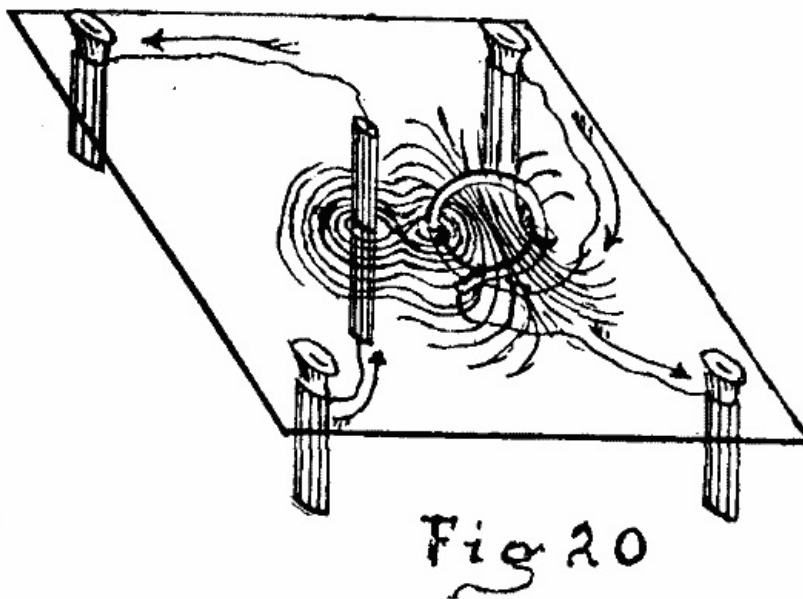

Fig. 20.

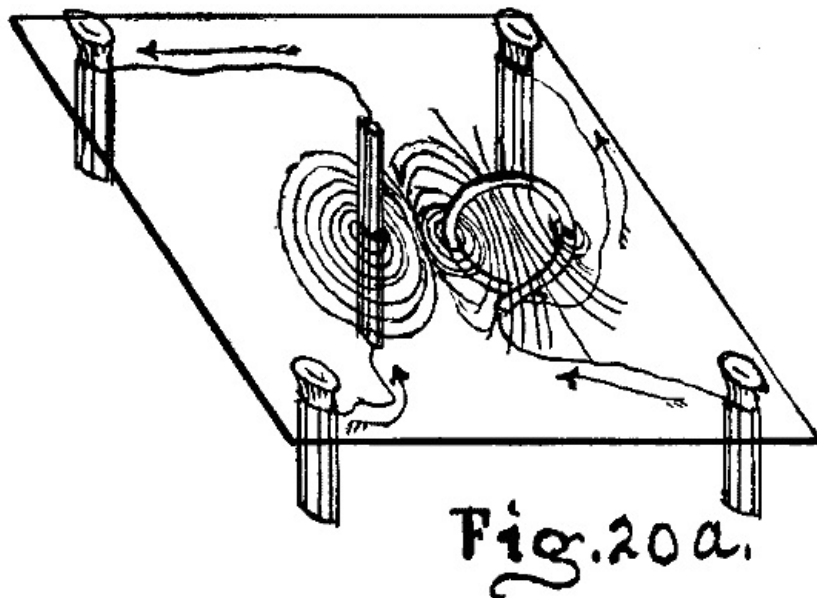

Fig. 20a.

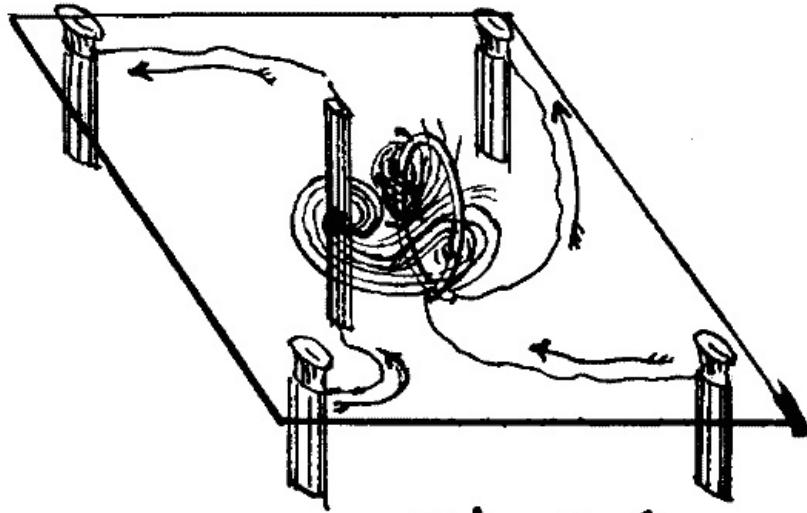

Fig 20b.

Fig. 20b.

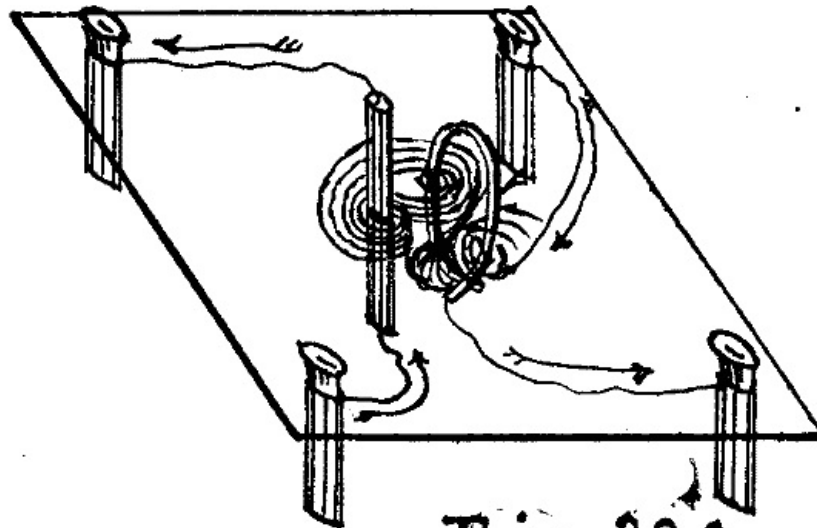

Fig. 20c.

Fig. 20c.

If the wire is placed parallel to the plane of the loop and to one side, Figs. 20b and 20c, there will be rotation (same as Figs. 4b and 4c).

If the loop is horizontal and the wire vertical and on one side, the Figs. 20d, 20e are the same as 4d and 4e.

If the loop is horizontal and the wire vertical and axial, 20f and 20g, there will be rotation, and the figures are mere duplicates of 4g and 4h.

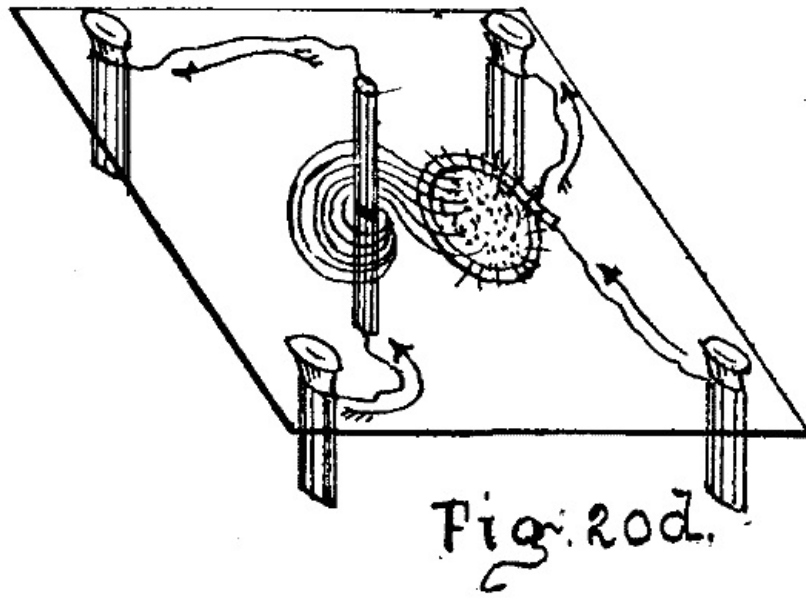

Fig. 20d.

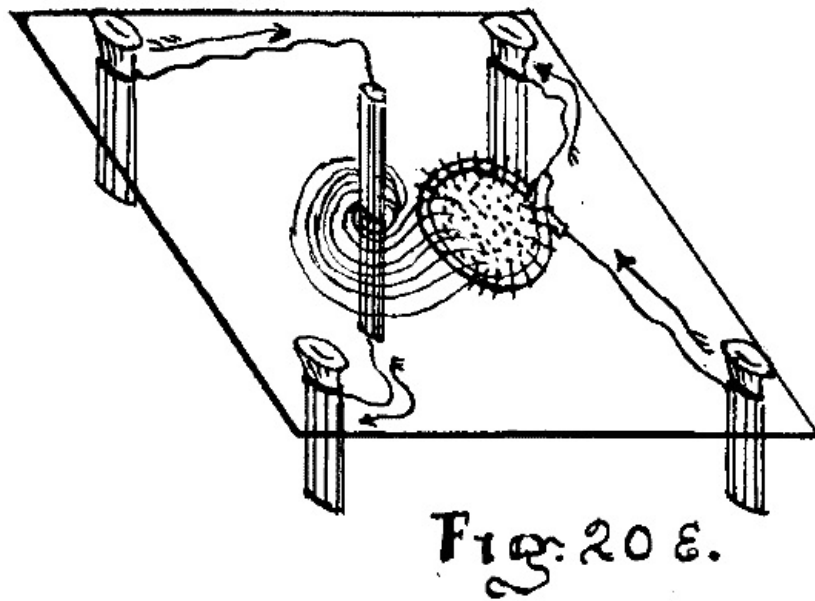

Fig. 20e.

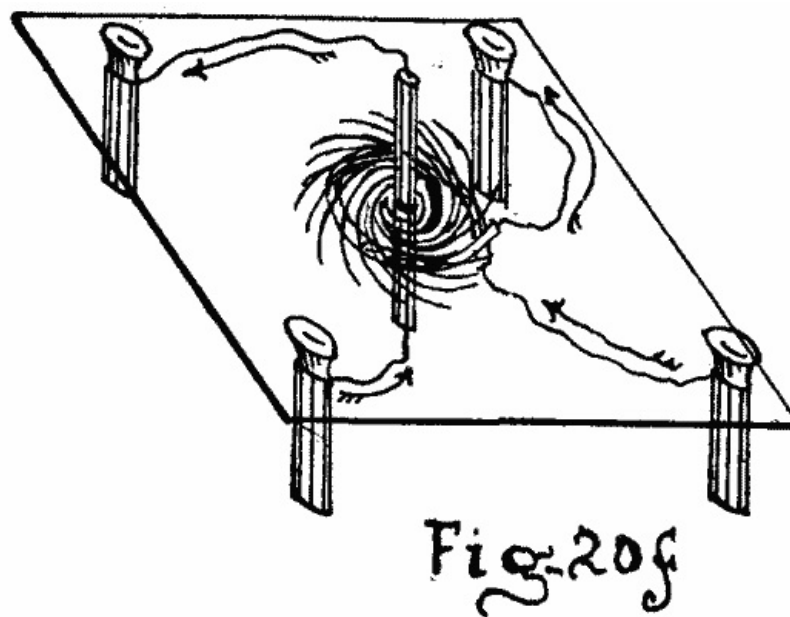

Fig. 20f.

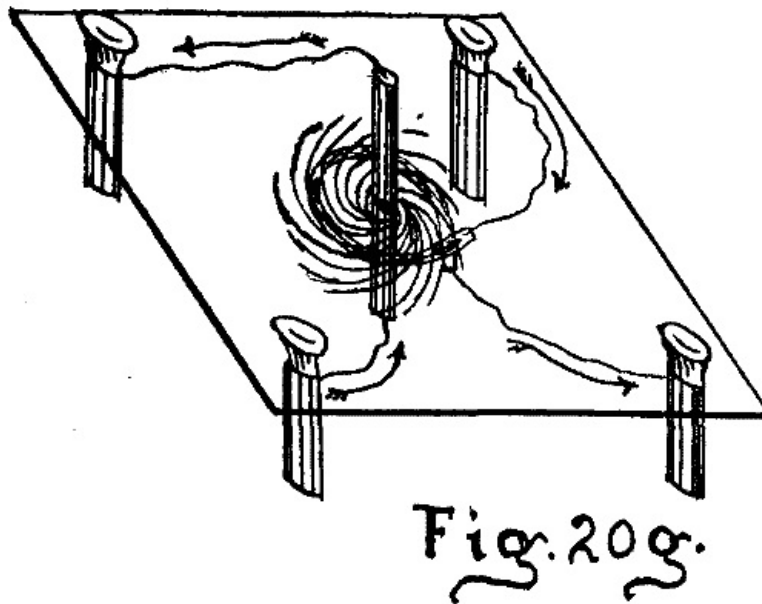

Fig. 20g.

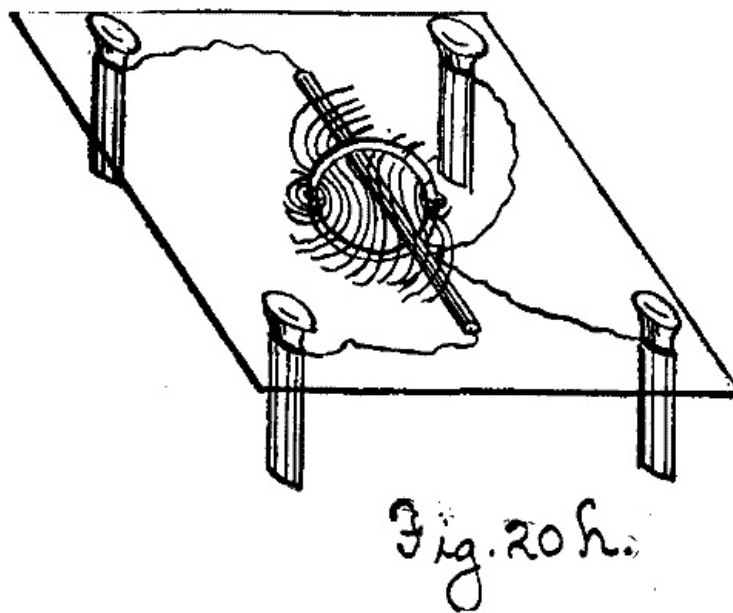

Fig. 20h.

Fig. 20h shows a view of 20f when the wire is horizontal and the plane of the loop vertical. It is like 4i.

To verify these facts, suspend a loop from Ampere's stand, Fig. 9, and bring a straight wire near.

A small rectangle or circle may be hung in a similar manner. When the circuit is closed, it tends to place itself with its axis in a N and S direction through the earth's influence. The supposition of an E and W horizontal earth current will explain this action.

To exemplify rotation of a vertical wire by a horizontal loop, Fig. 21 may be shown.

A circular copper vessel with a glass bottom (Fig. 21) has wound around its rim several turns of insulated wire. In the center of the vessel is a metallic upright upon the top of which is balanced in a mercury cup a light copper [inverted U] shaped strip. The ends of the inverted U dip into the dilute sulphuric acid contained in the circular vessel.

The current passes from, the battery, up the pillar, down the legs of the U to the liquid, thence through the insulated wire back to the battery.

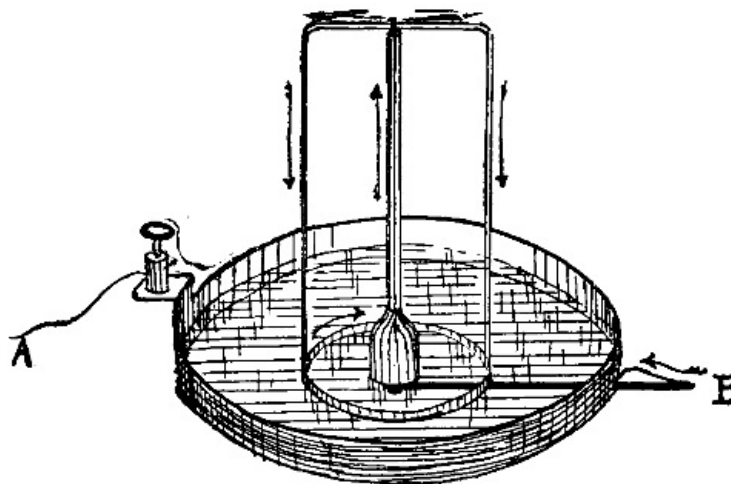

Fig. 21.

Fig. 21.

This is the usual form of apparatus, modified in size for the vertical or horizontal lantern.

(To be continued.)

[1]

An expansion of two papers read before the A.A.A.S. at the Ann Arbor meeting.

[2]

Electricity and Magnetism, Maxwell, p. 137, §§ 489, 490.

POISONS.

"Poisons and poisoning" was the subject of a discourse a few days ago at the Royal Institution. The lecturer, Professor Meymott Tidy, began by directing attention to the derivation of the word "toxicology," the science of poisons. The Greek word $\tau\omicron\chi\iota\sigma\upsilon$ signified primarily that specially oriental weapon which we call a bow, but the word in the earliest authors included in its meaning the arrow shot from the bow. Dioscorides in the first century A.D. uses the word $\tau\omicron\ \tau\omicron\chi\iota\kappa\omicron\nu$ to signify the poison to smear arrows with. Thus, by giving an enlarged sense to the word—for words ever strive to keep pace, if possible, with scientific progress, we get our modern and significant expression toxicology as the science of poisons and of poisoning. A certain grim historical interest gathers around the story of poisons.

It is a history worth studying, for poisons have played their part in history. The "subtil serpent" taught men the power of a poisoned fang. Poison was in the first instance a simple instrument of open warfare. Thus, our savage ancestors tipped their arrows with the snake poison in order to render them more deadly. The use of vegetable extracts for this purpose belongs to a later period. The suggestion is not unreasonable that if war chemists with their powders, their gun cotton, and their explosives had not been invented, warlike nations would have turned for their *instrumenta belli* to toxicologists and their poisons. At any rate, the toxicologists may claim that the very cradle of science was rocked in the laboratory of the toxicological worker. Early in the history of arrow tipping the admixture of blood with the snake poison became a common practice. Even the use of animal fluids alone is recorded—*e.g.*, the arrows of Hercules, which were dipped in the gall of the Lernæan hydra. Hercules himself at last fell a victim to the blood stained tunic of the dead Centaur Nessus. As late as the middle of the last century Blumenbach persuaded one of his class to drink 7 oz. of warm bullock's blood in order to disprove the then popular notion that even fresh blood was a poison. The young man who consented to drink the blood did not die a martyr to science.

The first important question we have to answer is, What do we mean by a poison? The law has not defined a poison, although it requires at times a definition. The popular definition of a poison is "a drug which destroys life rapidly when taken in small quantity." The terms "small quantity" as regards amount, and "rapidly" as regards time, are as indefinite as Hodge's "piece of chalk" as regards size. The professor defined a poison as "any substance which otherwise than by the agency of

heat or electricity is capable of destroying life, either by chemical action on the tissues of the living body or by physiological action by absorption into the living system." This definition excepted from the list of poisons all agencies that destroyed life by a simple mechanical action, thus drawing a distinction between a "poison" and a "destructive thing." It explains why nitrogen is not a poison and why carbonic acid is, although neither can support life. This point the lecturer illustrated. A poison must be capable of destroying life. It was nonsense to talk of a "deadly poison." If a body be a poison, it is deadly; if it be not deadly, it is not a poison. Three illustrations of the chemical actions of poisons were selected. The first was sulphuric acid. Here the molecular death of the part to which the acid was applied was due to the tendency of sulphuric acid to combine with water. The stomach became charred. The molecular death of certain tissues destroyed the general functional rhythmicity of the system until the disturbance became general, somatic death (that is, the death of the entire body) resulting. The second illustration was poisoning by carbonic oxide. The professor gave an illustrated description of the origin and properties of the coloring matter of the blood, known as *hæmoglobin*, drawing attention to its remarkable formation by a higher synthetical act from the albumenoids in the animal body, and to the circumstance that, contrary to general rule, both its oxidation and reduction may be easily effected. It was explained that on this rhythmic action of oxidizing and reducing *hæmoglobin* life depended.

Carbonic oxide, like oxygen, combined with *hæmoglobin*, produced a comparatively stable compound; at any rate, a compound so stable that it ceased to be the efficient oxygen carrier of normal *hæmoglobin*. This interference with the ordinary action of *hæmoglobin* constituted poisoning by carbonic oxide. In connection with this subject the lecturer referred to the use of the spectroscope as an analytical agent, and showed the audience the spectrum of blood extracted from the hat of the late Mr. Briggs (for the murder of whom Muller was executed), and this was the first case in which the spectroscopic appearances of blood formed the subject matter of evidence. The third illustration of poisoning was poisoning by strychnine. Here again the power of the drug for undergoing oxidation was illustrated. It was noted that although our knowledge of the precise *modus operandi* of the poison was imperfect, nevertheless that the coincidence of the first fit in the animal after its exhibition with the formation of reduced *hæmoglobin* in the body was important.

There followed upon this view of the chemical action of poison in the living body this question: Given a knowledge of certain properties of the elements—for example, their atomic weights, their relative position according to the periodic law, their spectroscopic character, and so forth—or given a knowledge of the molecular constitution, together with the general physical and chemical properties of compounds—in other words, given such knowledge of the element or compound as may be learned in a laboratory—does such knowledge afford us any clew whereby to predicate the probable action of the element or of the compound respectively on the living body? The researches of Blake, Rabuteau, Richet, Bouchardat, Fraser, and Crum-Brown were discussed, the results of their observations being that at present we were unable to determine toxicity or physiological action by any general chemical or physical researches. The lecturer pointed out that such relationship was scarcely to be expected. Poisons acted on different tissues, while even the same poison, according to the dose administered and other conditions, expended its toxic activity in different ways.

Further, the allotropic modifications of elements and the isomerism of compounds increased the difficulties. Why should yellow phosphorus be an active poison and red phosphorus be inert? Why should piperine be the poison of all poisons to keep you awake, and morphine the poison of all poisons to send you asleep, although to the chemist these two bodies were of identical composition? The lecturer urged that the science of medicine (for the poisons of the toxicologist were the medicines of the physician) must be experimental. Guard jealously against all wanton cruelty to animals; but to deprive the higher creation of life and health lest one of the lower creatures should suffer was the very refinement of cruelty. "Are ye not of much more value than they?" spoke a still small voice amid the noisy babble of well intentioned enthusiasts.—*London Times*.

ARTIFICIAL MOTHER FOR INFANTS.

All the journals have recently narrated the curious story of the triplets that were born prematurely at the clinic of Assas Street. Placed at their birth in an apparatus constructed on the principle of an incubator, in order to finish their development therein, these frail beings are doing wonderfully well, thanks to the assiduous care bestowed upon them, and are even showing, it appears, a true emulation to become persons of importance.

Every one now knows the incubator or "artificial hen"—that box with a glass top in which, under the influence of a mild heat, hens' eggs, laid upon wire cloth, hatch of

themselves in a few days, and allow pretty little chicks to make their way out of the cracked shell.

This ingenious apparatus, which has been adopted by most breeders, gives so good results that it has already supplanted the mother hens in all large poultry yards, and at present, thanks to it, large numbers of eggs that formerly ended in omelets are now changing into chickens.

Although not belonging to the same race, a number of children at their birth are none the less delicate than these little chicks.

There are some that are so puny and frail among the many brought into the world by the anæmic and jaded women of the present generation that, in the first days of their existence, their blood, incapable of warming them, threatens at every instant to congeal in their veins. There are some which, born prematurely, are so incapable of taking nourishment of themselves, of breathing and of moving, that they would be fatally condemned to death were not haste made to take up their development where nature left it, in order to carry it on and finish it. In such a case it is not, as might be supposed, to the exceptionally devoted care of the mother that the safety of these delicate existences is confided. As the sitting hen often interferes with the hatching of her eggs by too much solicitude, so the most loving and attentive mother, in this case, would certainly prove more prejudicial than useful to her nursling. So, for this difficult task that she cannot perform, there is advantageously substituted for her what is known as an artificial mother. This apparatus, which is identical with the one employed for the incubation of chickens, consists of a large square box, supporting, upon a double bottom, a series of bowls of warm water. Above these vessels, which are renewed as soon as the temperature lowers, is arranged a basket filled with cotton, and in this is laid, as in a nest, the weak creature which could not exist in the open air.

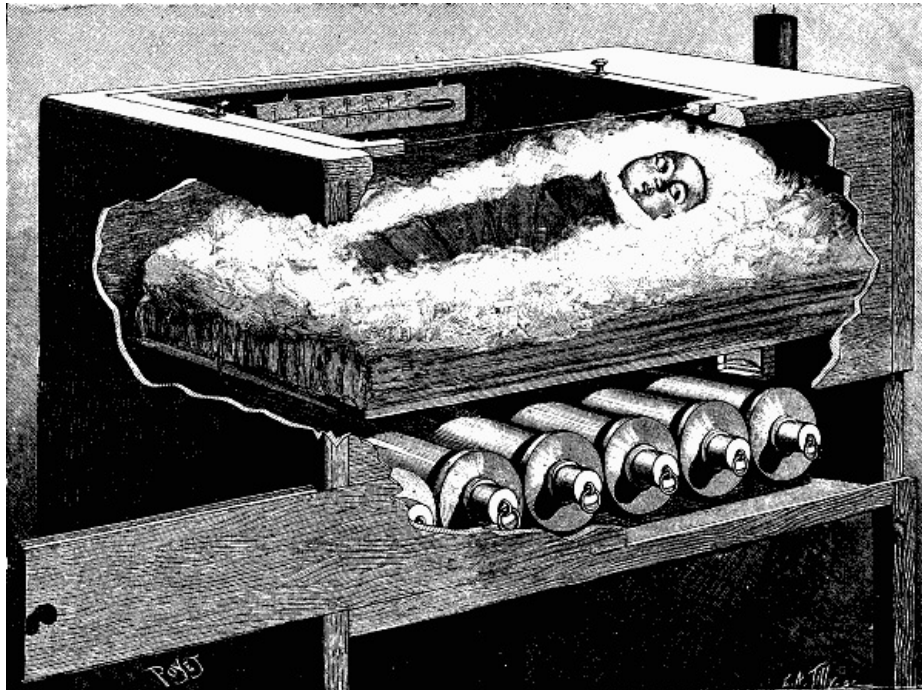

STILL BIRTH WARMING APPARATUS.

Through the glass in the cover, the mother has every opportunity of watching the growth of her new born babe; but this is all that she is allowed to do. The feeding of the infant, which is regulated by the physician at regular hours, is effected by means of a special rubber apparatus, through the aid of an intelligent woman who has sole charge of this essential operation. The aeration of the little being, which is no less important, is assured by a free circulation, in the box, of pure warm air, which is kept at a definite temperature and is constantly renewed through a draught flue. The least variations in the temperature are easily seen through a horizontal thermometer placed beneath the glass.

Thus protected against all those bad influences that are often so fatal at the inception of life, even to the healthiest babes, preserved from an excess or insufficiency of food, sheltered from cold and dampness, protected against clumsy handling and against pernicious microbes, sickly or prematurely born babies soon acquire enough strength in the apparatus to be able, finally, like others, to face the various perils that await us from the cradle.

The results that have been obtained for some time back at Paris, where the surroundings are so unfavorable, no longer leave any doubt as to the excellence of the process. At the lying-in clinic of Assas Street, Doctors Farnier, Chantreuil, and

Budin succeeded in a few days in bringing some infants born at six months (genuine human dolls, weighing scarcely more than from 2¼ to 4½ pounds) up to the normal weight of 7½ pounds.—*L'Illustration*.

GASTROSTOMY.

Surgery has, as is well known, made great progress in recent years. Apropos of this subject, we shall describe to our readers an operation that was recently performed by one of our most skillful surgeons, Dr. Terrillon, under peculiar circumstances, in which success is quite rare. The subject was a man whose œsophagus was obstructed, and who could no longer swallow any food, or drink the least quantity of liquid, and to whom death was imminent. Dr. Terrillon made an incision in the patient's stomach, and, through a tube, enabled him to take nourishment and regain his strength. We borrow a few details concerning the operation from a note presented by the doctor at one of the last meetings of the Academy of Medicine.



FIG. 1.—FEEDING A PATIENT THROUGH A STOMACHAL TUBE.

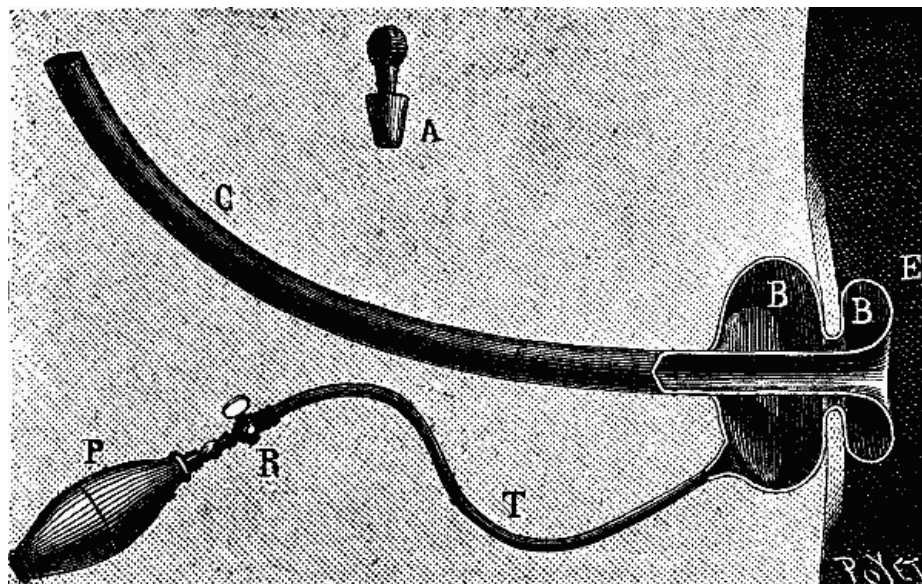

FIG. 2.—DETAILS OF THE TUBE. C, rubber tube for leading food to the stomach, E; B B', rubber balls, which, inflated with air by means of the tube, T, and rubber ball, P, effect a hermetic closing; A, stopper for the tube, C; R, cock of the air tube.

Mr. X., fifty-three years of age, is a strong man of arthritic temperament. He has suffered for several years with violent gastralgia and obstinate dyspepsia, for which he has long used morphine. The œsophageal symptoms appear to date back to the month of September, 1887, when he had a painful regurgitation of a certain quantity of meat that he had swallowed somewhat rapidly.

Since that epoch, the passage of solid food has been either painful or difficult, and often followed by regurgitation. The food seemed to stop at the level of the pit of the stomach. So he gave up solid food, and confined himself to liquids or semi-liquids, which readily passed up to December 20, 1887. At this epoch, he remarked that liquids were swallowed with difficulty, especially at certain moments, they remaining behind the sternum and afterward slowly descending or being regurgitated. This state of things was more marked especially in the first part of January. He was successfully sounded several times, but soon the sound was not able to pass. Doctors Affre and Bazenet got him to come to Paris, where he arrived February 5, 1888.

For ten days, the patient had not been able to swallow anything but about a quart of milk or bouillon in small doses. As soon as he had swallowed the liquid, he experienced distress over the pit of the stomach, followed by painful regurgitations. For three days, every attempt made by Dr. Terrillon to remove the obstacle that evidently existed at the level of the cardia entirely failed. Several times after such attempts a little blood was brought out, but there was never any hemorrhage.

The patient suffered, grew lean and impatient, and was unable to introduce into his stomach anything but a few spoonfuls of water from time to time. As he was not cachectic and no apparent ganglion was found, and as his thoracic respiration was perfect, it seemed to be indicated that an incision should be made in his stomach. The patient at once consented.

The operation was performed February 9, at 11 o'clock, with the aid of Dr. Routier, the patient being under the influence of chloroform. A small aperture was made in the wall of the stomach and a red rubber sound was at once introduced in the direction of the cardia and great tuberosity. This gave exit to some yellowish gastric liquid. The tube was fixed in the abdominal wall with a silver wire. The operation took three quarters of an hour. The patient was not unduly weakened, and awoke a short time afterward. He had no nausea, but merely a burning thirst. The operation was followed by no peritoneal reaction or fever. Three hours afterward, bouillon and milk were injected and easily digested.

Passing in silence the technical details, which would not interest the majority of our readers, we shall be content to say that Mr. X., thanks to this alimentation, has regained his strength, and is daily taking his food as shown in Fig. 1. The aperture made in the stomach permits of the introduction of the rubber apparatus shown in Fig. 2, the object of which is to prevent the egress of the liquids of the stomach and at the same time to introduce food. A funnel is fitted to the tube, and the liquid or semi-liquid food is directly poured into the stomach. Digestion proceeds with perfect regularity, and Mr. X., who has presented himself, of his own accord, before the Academy, and whom we have recently seen, has resumed his health and good spirits.
—*La Nature*.

HOW TO CATCH AND PRESERVE MOTHS AND BUTTERFLIES.

There is no part of our country in which one cannot form a beautiful local collection, and any young person who wants amusement, instruction, and benefit from two, three, or more weeks in the country can find all in catching butterflies and moths, arranging them, and studying them up.

Provide yourself first with two tools, a net and a poison bottle. The net may be made of any light material. I find the thinnest Swiss muslin best. Get a piece of iron wire, not as heavy as telegraph wire, bend it in a circle of about ten inches diameter, with the ends projecting from the circle two or three inches; lash this net frame to the end of a light stick four or five feet long. Sew the net on the wire. The net must be a bag whose depth is not quite the length of your arm—so deep that when you hold the wire in one hand you can easily reach the bottom with the bottle (to be described) in the other hand. Never touch wing of moth or butterfly with your fingers. The colors are in the dusty down (as you call it), which comes off at a touch. Get a glass bottle or vial, with large, open mouth, and cork which you can easily put in and take out. The bottles in which druggists usually get quinine are the most convenient. It should not be so large that you cannot easily carry it in your pocket. Let the druggist put in the bottle a half ounce of cyanide of potassium; on this pour water to the depth of about three-fourths of an inch, and then sprinkle in and mix gently and evenly enough plaster of Paris to form a thick cream, which will *set* in a cake in the bottom of the vial. Let it stand open an hour to set and dry, then wipe out the inside of the vial above the cake and keep it corked. This is the regular entomological poison bottle, used everywhere. An insect put in it dies quietly at once. It will last several months.

These two tools, the net and the poison bottle, are your catching and killing

instruments. You know where to look for butterflies. Moths are vastly more numerous, and while equally beautiful, present more varieties of beauty than butterflies. They can be found by daylight in all kinds of weather, in the grass fields, in brush, in dark woods, sometimes on flowers. Many spend the daytime spread out, others with close shut wings on the trunks of trees in dark woods. The night moths are more numerous and of great variety. They come around lamps, set out on verandas in the night, in great numbers. A European fashion is to spread on tree trunks a sirup made of brown sugar and rum, and visit them once in a while at night with net and lantern. Catch your moth in the net, take him out of it by cornering him with the open mouth of your poison bottle, so that you secure him unrubbed.

Now comes the work of stretching your moths. This is easy, but must be done carefully. Provide your own stretching boards. These can be made anywhere with hammer and nail and strips of wood. You want two flat strips of wood about seven-eighths or three-fourths of an inch thick and eight to fourteen inches long, nailed parallel to each other on another strip, so as to leave a narrow open space between the two parallel strips. Make two or three or more of these, with the slit or space between the strips of various widths, for large and small moths and butterflies. Make as many of them, with as various widths of slit, as your catches may demand. Take your moth by the feet, gently in your fingers, put a long pin down through his body, set the pin down in the slit of the stretching board, so that the body of the moth will be at the top of the slit and the wings can be laid out flat on the boards on each side. Have ready narrow slips of white paper. Lay out one *upper* wing flat, raising it gently and carefully by using the point of a pin to draw it with, until the lower edge of this upper wing is nearly at a right angle with the body. Pin it there temporarily with one pin, carefully, while you draw up the *under* wing to a natural position, and pin that. Put a slip of paper over both wings, pinning one end above the upper and the other below the under wing, thus holding both wings flat on the stretching board. Take out the pins first put in the wings and let the paper do the holding. Treat the opposite wings in the same way. Put as many moths or butterflies on your stretching board as it will hold, and let them remain in a dry room for two, three, or more days, according to size of moths and dampness of climate. Put them in sunshine or near a stove to hasten drying. When dry, take off the slips of paper, lift the moth out by the pin through the body, and place him permanently in your collection.—*Wm. C. Prime, in N. Y. Jour. of Commerce.*

THE CLAVI HARP.

The beautiful instrument which we illustrate to-day is the invention of M. Dietz, of Brussels. His grandfather was one of the first manufacturers of upright pianos, and being struck with the difficulties and defects of the harp, constructed, in 1810, an instrument *à cordes pincées à clavier*—the strings connected with a keyboard.

Many improvements have from time to time been made on this model, which at last arrived at the perfection exhibited in the newly patented clavi harp. The difficulty of learning to play the ordinary harp, and the inherent inconveniences of the instrument, limit its use. It is furnished with catgut strings, which are affected by all the influences of temperature, and require to be frequently tuned. The necessity of playing the strings with the fingers renders it difficult to obtain equality in the sounds. It gives only the natural sounds of the diatonic gamut, and in order to obtain changes of modulation, the pedals must be employed. Harmonics and shakes are very difficult to execute on the harp, and—last, but not least—it is not provided with dampers. The external form of the clavi harp resembles that of the harp, and all the cords, or strings, are visible. The mechanism which produces the sound is put into motion directly a key is depressed, and acts in a similar manner to the fingers of a harpist; the strings being pulled, not struck. The clavi harp is free from all the objections inherent in the ordinary harp. The strings are of a peculiar metal, covered with an insulating material, which has for its object the production of sounds similar to that obtained from catgut strings, and to prevent the strings from falling out of tune. The keyboard, exactly like that of a piano, permits of playing in all keys, without the employment of pedals. The clavi harp has two pedals. The first, connected with the dampers, permits the playing of sustained sounds, or damping them instantaneously. The second pedal divides certain strings into two equal parts, to give the harmonic octaves; by the aid of this pedal the performer can produce ten harmonic sounds simultaneously; on the ordinary harp only four simultaneous harmonics are possible. An ordinary keyboard being the intermediary between the performer and the movement of the mechanical "fingers" which pluck the strings, perfect equality of manipulation is secured. The mechanical "fingers" instantaneously quit the strings on which they operate, and are ready for further action. The "fingers" are covered with suitable material, so that their contact with the strings takes place with the softness necessary to obtain the most beautiful tones possible.



THE CLAVI HARP.

The clavi harp is much lighter than the piano—so that it can easily be moved from room to room, or taken into an orchestra, by one or two persons—and is of an elegant form, favorable to artistic decoration. Sufficient will have been said to give a general idea of the new instrument.

It is undeniable that at the present day that beautiful instrument, the harp, is seldom played; still seldomer well played. This is attributable to the difficulties it presents to pupils. Its seven pedals must be employed in different ways when notes are to be raised or lowered a semitone; chromatic passages easy of execution on the piano are almost impracticable on the harp. The same may be said of the shake; and it is only after long and exclusive devotion to its study that the harp can become endurable in the hands of an amateur, or the means of furnishing a professional harpist with a moderate income. It is needless to point out how far, in these respects, the harp is surpassed by the clavi harp.

Vocalists who accompany themselves on the harp are forced, by the extension of their arms to reach the lower strings, and by frequent employment of their feet on the pedals, into postures and movements unfavorable to voice production; but they can accompany themselves with ease on the clavi harp.

Composers are restricted in the introduction of harp passages in their orchestral scores, owing to the paucity of harpists. In some cases, composers have written harp passages beyond the possibility of execution by a single harpist, and the difficulty and cost of providing two harpists have been inevitable. These difficulties will disappear, and composers may give full play to their inspirations, when the harp is displaced by the clavi harp.—*Building News*.

THE ARGAND BURNER.

Argand, a poor Swiss, invented a lamp with a wick fitted into a hollow cylinder, up which a current of air was permitted to pass, thus giving a supply of oxygen to the interior as well as the exterior of the circular frame. At first Argand used the lamp without a glass chimney. One day he was busy in his work room and sitting before the burning lamp. His little brother was amusing himself by placing a bottomless oil flask over different articles. Suddenly he placed it upon the flame of the lamp, which instantly shot up the long, circular neck of the flask with increased brilliancy. It did more, for it flashed into Argand's mind the idea of the lamp chimney, by which his invention was perfected.

THE SUBTERRANEAN TEMPLES OF INDIA.

During the last fifteen years Bombay has undergone a complete transformation, and the English are now making of it one of the prettiest cities that it is possible to see. The environs likewise have been improved, and thanks to the railways and *bungalows* (inns), many excursions may now be easily made, and tourists can thus visit the wonders of India, such as the subterranean temples of Ajunta, Elephanta, Nassik, etc., without the difficulties of heretofore.

The excavations of Elephanta are very near Bombay, and the trip in the bay by boat

to the island where they are located is a delightful one. The deplorable state in which these temples now exist, with their broken columns and statues, detracts much from their interest. The temples of Ajunta, perhaps the most interesting of all, are easier of access, and are situated 250 miles from Bombay and far from the railway station at Pachora, where it is necessary to leave the cars. Here an ox cart has to be obtained, and thirty miles have to be traveled over roads that are almost impassable. It takes the oxen fifteen hours to reach the bungalow of Furdapore, the last village before the temples, and so it is necessary to purchase provisions. In these wild and most picturesque places, the Hindoos cannot give you a dinner, even of the most primitive character. It was formerly thought that the subterranean temples of India were of an extraordinary antiquity.

The Hindoos still say that the gods constructed these works, but of the national history of the country they are entirely ignorant, and they do not, so to speak, know how to estimate the value of a century. The researches made by Mr. Jas. Prinsep between 1830 and 1840 have enlightened the scientific world as to the antiquity of the monuments of India. He succeeded in deciphering the Buddhist inscriptions that exist in all the north of India beyond the Indus as far as to the banks of the Bengal. These discoveries opened the way to the work done by Mr. Turnour on the Buddhist literature of Ceylon, and it was thus that was determined the date of the birth of Sakya Muni, the founder of Buddhism. He was born 625 B.C. and his death occurred eighty years later, in 543. It is also certain that Buddhism did not become a true religion until 300 years after these events, under the reign of Aoska. The first subterranean temples cannot therefore be of a greater antiquity. Researches that have been made more recently have in all cases confirmed these different results, and we can now no longer doubt that these temples have been excavated within a period of fourteen centuries.

Dasaratha, the grandson of Aoska, first excavated the temples known under the name of Milkmaid, in Behar (Bengal), 200 B.C., and the finishing of the last monument of Ellora, dedicated by Indradyumna to Indra Subha, occurred during the twelfth century of our era.

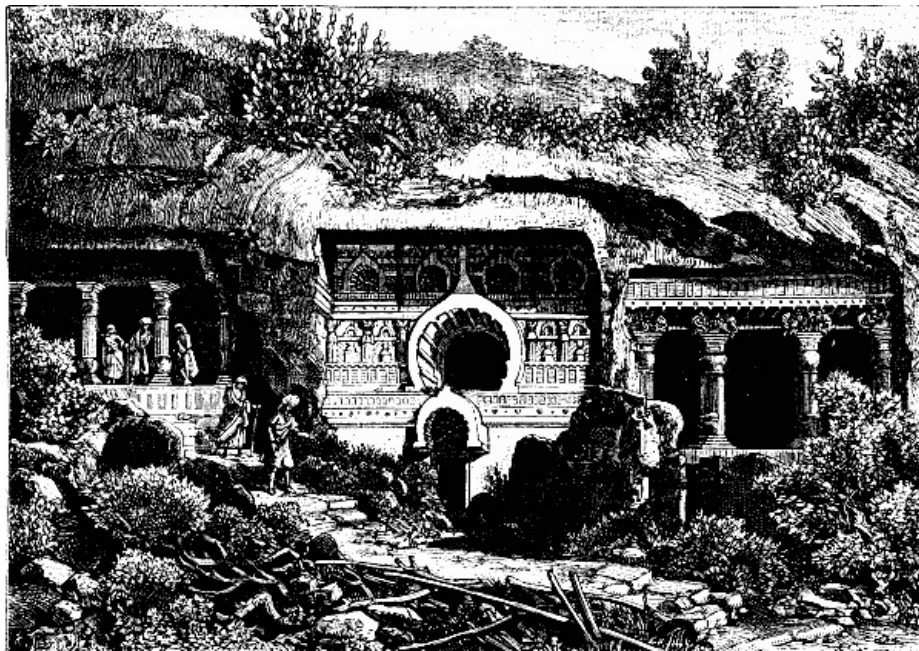

FIG. 1.—FACADE OF THE TEMPLE OF PANDU LENA.

We shall speak first of the temples of Pandu Lena, situated in the vicinity of Nassik, near Bombay. These are less frequented by travelers, and that is why I desired to make a sketch of them (Fig. 1). The church of Pandu Lena is very ancient. Inscriptions have been found upon its front, and in the interior on one of the pillars, that teach us that it was excavated by an inhabitant of Nassik, under the reign of King Krishna, in honor of King Badrakaraka, the fifth of the dynasty of Sunga, who mounted the throne 129 B.C.

The front of this church, all carved in the rock, is especially remarkable by the perfection of the ornaments. In these it is to be seen that the artist has endeavored to imitate in rock a structure made of wood. This is the case in nearly all the subterranean temples, and it is presumable that the architects of the time did their composing after the reminiscences of the antique wooden monuments that still existed in India at their epoch, but which for a long time have been forever destroyed. The large bay placed over the small front door gives a mysterious light in the nave of the church, and sends the rays directly upon the main altar or *dagoba*, leaving the lateral columns and porticoes in a semi-obscurity well calculated to inspire meditation and prayer.

The temples and monasteries of Ajunta, too, are of the highest interest. They consist of 27 grottoes, of which four only are churches or *chaityas*. The 23 other excavations compose the monasteries or *viharas*. Begun 100 B.C., they have remained since the tenth century of our era as we now see them. The subterranean monasteries are majestic in appearance. Sustained by superb columns with curiously sculptured capitals, they are ornamented with admirable frescoes which make us live over again the ancient Hindoo life. The paintings are unfortunately in a sad state, yet for the tourist they are an inexhaustible source of interesting observations.

The excavations, which have been made one after another in the wall of volcanic rock of the mountain, form, like the latter, a sort of semicircle. But the churches and monasteries have fronts whose richness of ornamentation is unequalled. The profusion of the sculptures and friezes, ornamented with the most artistic taste, strikes you with so much the more admiration in that in these places they offer a perfect and varied *ensemble* of the true type of the Buddhist religion during this long period of centuries. The picturesque landscape that surrounds these astonishing sculptures adds to the beauty of these various pictures.

The temples of Ellora are no less remarkable, but they do not offer the same artistic *ensemble*. The excavations may be divided into three series: ten of them belong to the religion of Buddha, fourteen to that of Brahma, and six to the Dravidian sect, which resembles that of Jaius, of which we still have numerous specimens in the Indies. Excavated in the same amygdaloid rock, the temples and monasteries differ in aspect from those of Ajunta, on account of the form of the mountain. Ajunta is a nearly vertical wall. At Ellora, the rock has a gentle slope, so that, in order to have the desired height for excavating the immense halls of the *viharas* or the naves of the *chaityas*, it became necessary to carve out a sort of forecourt in front of each excavation.

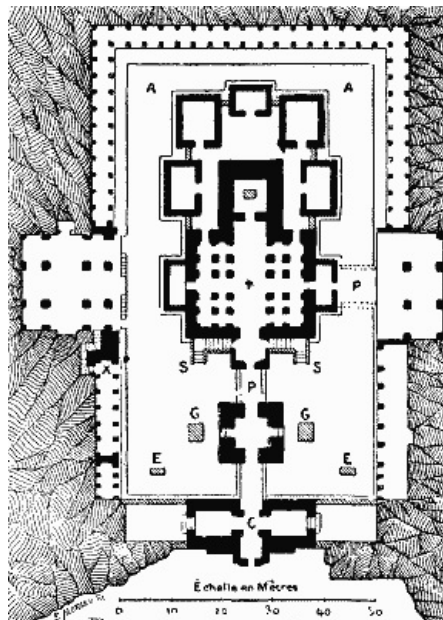

FIG. 2.—PLAN OF THE TEMPLES OF KYLAS.

Some of the churches thus have their entrance ornamented with porticoes, and the immense monasteries (which are sometimes three stories high) with lateral entrances and facades. The mountain has also been excavated in other places, so as to form a relatively narrow entrance, which gives access to the internal court of one of these monasteries. It thus becomes nearly invisible to whoever passes along the road formed on the sloping side of the mountain. The greatest curiosity among the monuments of Ellora is the group of temples known by the name of Kylas (Fig. 2). The monks have excavated the rocky slope on three faces so as to isolate completely, in the center, an immense block, out of which they have carved an admirable temple (see T in the plan, Fig. 2), with its annexed chapels. These temples are thus roofless and are sculptured externally in the form of pagodas. Literally covered with sculptures composed with infinite art, they form a very unique collection. These temples seem to rest upon a fantastic base in which are carved in alto rilievo all the gods of Hindoo mythology, along with symbolic monsters and rows of elephants. These are so many caryatides of strange and mysterious aspect, certainly designed to strike the imagination of the ancient Indian population (Fig. 3).

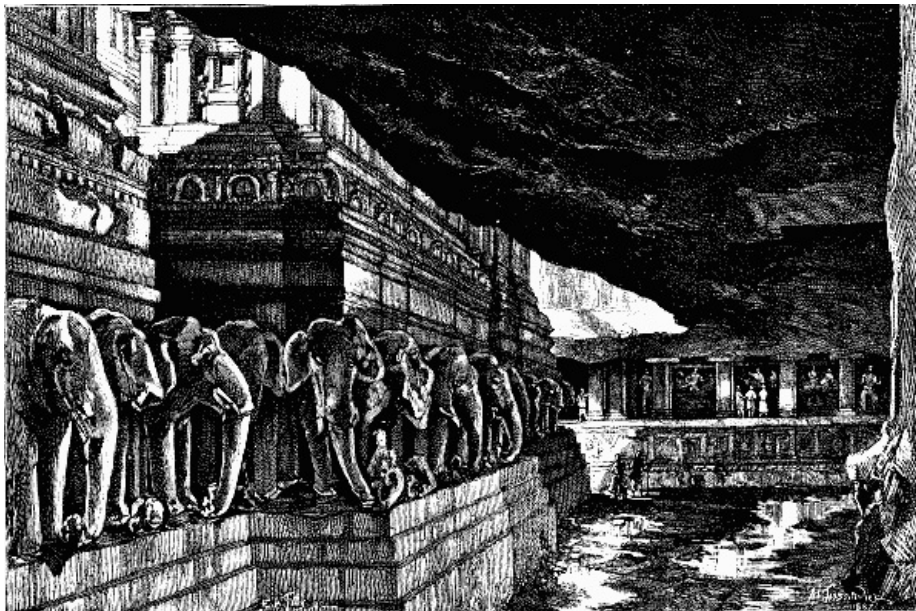

FIG. 3.—SUBTERRANEAN TEMPLE AT ELLORA.

Two flights of steps at S and S (Fig. 2) near the main entrance of Kylas lead to the top of this unique base and to the floor of the temples.

The interior of the central pagoda, ornamented with sixteen magnificent columns, formerly covered, like the walls, with paintings, and the central sanctuary that contains the great idol, are composed with a perfect understanding of architectural proportions.

Exit from this temple is effected through two doors at the sides. These open upon a platform where there are five pagodas of smaller size that equal the central temple in the beauty of their sculptures and the elegance of their proportions.

Around these temples great excavations have been made in the sides of the mountain. At A (Fig. 2), on a level with the ground, is seen a great cloister ornamented with a series of bass reliefs representing the principal gods of the Hindoo paradise. The side walls contain large, two-storied halls ornamented with superb sculptures of various divinities. Columns of squat proportions support the ceilings. A small stairway, X (Fig. 2), leads to one of these halls. Communication was formerly had with its counterpart by a stone bridge which is now broken. There still exist two (P) which lead from the floor of the central temple to the first story of the detached pavilion or *mantapa*, D, and to that of the entrance pavilion or *gopura*, C. At G we still see two sorts of obelisks ornamented with arabesques and designed for holding the fires during religious fetes. At E are seen two colossal elephants carved out of the rock. These structures, made upon a general plan of remarkable character, are truly without an equal in the entire world.

We may thus see how much art feeling the architects of these remote epochs possessed, and express our wonder at the extreme taste that presided over all these marvelous subterranean structures.—A. Tissandier, in *La Nature*.

[NATURE.]

TIMBER, AND SOME OF ITS DISEASES.¹

By H. MARSHALL WARD.

IV.

Before proceeding further it will be of advantage to describe another tree-killing fungus, which has long been well known to mycologists as one of the commonest of our toadstools growing from rotten stumps and decaying wood-work such as old water pipes, bridges, etc. This is *Agaricus melleus* (Fig. 15), a tawny yellow toadstool with a ring round its stem, and its gills running down on the stem and bearing white spores, and which springs in tufts from the base of dead and dying trees during September and October. It is very common in this country, and I have often found it on beeches and other trees in Surrey, but it has been regarded as simply springing from the dead rotten wood, etc., at the base of the tree. As a matter of fact, however, this toadstool is traced to a series of dark shining strings, looking almost like the purple-black leaf stalks of the maidenhair fern, and these strings branch and meander in the wood of the tree, and in the soil, and may attain even great lengths—several feet, for instance. The interest of all this is enhanced when we know that

until the last few years these long black cords were supposed to be a peculiar form of fungus, and were known as *Rhizomorpha*. They are, however, the subterranean vegetative parts (mycelium) of the agaric we are concerned with, and they can be traced without break of continuity from the base of the toadstool into the soil and tree (Fig. 16). I have several times followed these dark mycelial cords into the timber of old beeches and spruce fir stumps, but they are also to be found in oaks, plums, various conifers, and probably may occur in most of our timber trees if opportunity offers.

The most important point in this connection is that *Agaricus melleus* becomes in these cases a true parasite, producing fatal disease in the attacked timber trees, and, as Hartig has conclusively proved, spreading from one tree to another by means of the rhizomorphs under ground. Only the last summer I had an opportunity of witnessing, on a large scale, the damage that can be done to timber by this fungus. Hundreds of spruce firs with fine tall stems, growing on the hillsides of a valley in the Bavarian Alps, were shown to me as "victims to a kind of rot." In most cases the trees (which at first sight appeared only slightly unhealthy) gave a hollow sound when struck, and the foresters told me that nearly every tree was rotten at the core. I had found the mycelium of *Agaricus melleus* in the rotting stumps of previously felled trees all up and down the same valley, but it was not satisfactory to simply assume that the "rot" was the same in both cases, though the foresters assured me it was so.



FIG. 15.—A small group of *Agaricus (Armillaria) melleus*. The toadstool is tawny yellow, and produces white spores; the gills are decurrent, and the stem bears a ring. The fine hair-like appendages on the pileus should be bolder.

By the kindness of the forest manager I was allowed to fell one of these trees. It was chosen at hazard, after the men had struck a large number, to show me how easily the hollow trees could be detected by the sound. The tree was felled by sawing close to the roots; the interior was hollow for several feet up the stem, and two of the main roots were hollow as far as we could poke canes, and no doubt further. The dark-colored rotting mass around the hollow was wet and spongy, and consisted of disintegrated wood held together by a mesh work of the rhizomorphs. Further outward the wood was yellow, with white patches scattered in the yellow matrix, and, again, the rhizomorph strands were seen running in all directions through the mass.

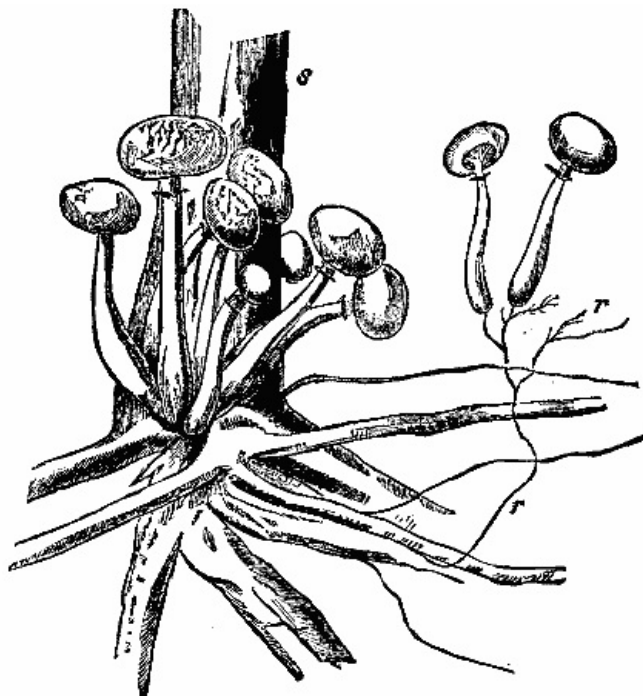

FIG. 16.—Sketch of the base of a young tree (*s*) killed by *Agaricus melleus*, which has attacked the roots, and developed rhizomorphs at *r*, and fructifications. To the right the fructifications have been traced by dissection to the rhizomorph strands which produced them.

Not to follow this particular case further—since we are concerned with the general features of the diseases of timber—I may pass to the consideration of the diagnosis of this disease caused by *Agaricus melleus*, as contrasted with that due to *Trametes radiciperda*.

Of course no botanist would confound the fructification of the *Trametes* with that of the *Agaricus*; but the fructifications of such fungi only appear at certain seasons, and that of *Trametes radiciperda* may be underground, and it is important to be able to distinguish such forms in the absence of the fructifications.

The external symptoms of the disease, where young trees are concerned, are similar in both cases. In a plantation at Freising, in Bavaria, Prof. Hartig showed me young Weymouth pines (*P. Strobus*) attacked and killed by *Agaricus melleus*. The leaves turn pale and yellow, and the lower part of the stem—the so-called "collar"—begins to die and rot, the cortex above still looking healthy. So far the symptoms might be those due to the destructive action of other forms of tree-killing fungi.

On uprooting a young pine, killed or badly attacked by the agaric, the roots are found to be matted together with a ball of earth permeated by the resin which has flowed out; this is very pronounced in the case of some pines, less so in others. On lifting up the scales of the bark, there will be found, not the silky white, delicate mycelium of the *Trametes*, but probably the dark cord-like rhizomorphs; there may also be flat white rhizomorphs in the young stages, but they are easily distinguished. These dark rhizomorphs may also be found spreading around into the soil from the roots, and they look so much like thin roots indeed that we can at once understand their name—rhizomorph. The presence of the rhizomorphs and (in the case of the resinous pines) the outflow of resin and sticking together of soil and roots are good distinctive features. No less evident are the differences to be found on examining the diseased timber, as exemplified by Prof. Hartig's magnificent specimens. The wood attacked assumes brown and bright yellow colors, and is marked by sharp brown or nearly black lines, bounding areas of one color and separating them from areas of another color. In some cases the yellow color is quite bright—canary yellow, or nearly so. The white areas scattered in this yellow matrix have no black specks in them, and can thus be distinguished from those due to the *Trametes*. In advanced stages the purple-black rhizomorphs will be found in the soft, spongy wood.

The great danger of *Agaricus melleus* is its power of extending itself beneath the soil by means of the spreading rhizomorphs; these are known to reach lengths of several feet, and to pass from root to root, keeping a more or less horizontal course at a depth of six or eight inches or so in the ground. On reaching the root of another tree, the tips of the branched rhizomorph penetrate the living cortex, and grow forward in the plane of the cambium, sending off smaller ramifications into the medullary rays and (in the case of the pines, etc.) into the resin passages. The hyphæ of the ultimate twigs enter the tracheides, vessels, etc., of the wood, and delignify them, with changes of color and substance as described. Reference must be made to Prof. Hartig's publications for the details which serve to distinguish histologically between

timber attacked by *Agaricus melleus* and by *Trametes* or other fungi. Enough has been said to show that diagnosis is possible, and indeed to an expert not difficult.

It is at least clear from the above sketch that we can distinguish these two kinds of diseases of timber, and it will be seen on reflection that this depends on knowledge of the structure and functions of the timber and cambium on the one hand and proper acquaintance with the biology of the fungi on the other. It is the victory of the fungus over the timber in the struggle for existence which brings about the disease; and one who is ignorant of these points will be apt to go astray in any reasoning which concerns the whole question. Any one knowing the facts and understanding their bearings, on the contrary, possesses the key to a reasonable treatment of the timber; and this is important, because the two diseases referred to can be eradicated from young plantations and the areas of their ravages limited in older forests.

Suppose, for example, a plantation presents the following case. A tree is found to turn sickly and die, with the symptoms described, and trees immediately surrounding it are turning yellow. The first tree is at once cut down, and its roots and timber examined, and the diagnosis shows the presence of *Agaricus melleus* or of *Trametes radiciperda*, as the case may be. Knowing this, the expert also knows more. If the timber is being destroyed by the *Trametes*, he knows that the ravaging agent can travel from tree to tree by means of roots in contact, and he at once cuts a ditch around the diseased area, taking care to include the recently infected and neighboring trees. Then the diseased timber is cut, because it will get worse the longer it stands, and the diseased parts burnt. If *Agaricus melleus* is the destroying agent, a similar procedure is necessary; but regard must be had to the much more extensive wanderings of the rhizomorphs in the soil, and it may be imperative to cut the moat round more of the neighboring trees. Nevertheless, it has also to be remembered that the rhizomorphs run not far below the surface. However, my purpose here is not to treat this subject in detail, but to indicate the lines along which practical application of the truths of botanical science may be looked for. The reader who wishes to go further into the subject may consult special works. Of course the spores are a source of danger, but need be by no means so much so where knowledge is intelligently applied in removing young fructifications.

I will now pass on to a few remarks on a class of disease-producing timber fungi which present certain peculiarities in their biology. The two fungi which have been described are true parasites, attacking the roots of living trees, and causing disease in the timber by traveling up the cambium, etc., into the stem; the fungi I am about to refer to are termed wound parasites, because they attack the timber of trees at the surfaces of wounds, such as cut branches, torn bark, frost cracks, etc., and spread from thence into the sound timber. When we are reminded how many sources of danger are here open in the shape of wounds, there is no room for wonder that such fungi as these are so widely spread. Squirrels, rats, cattle, etc., nibble or rub off bark; snow and dew break branches; insects bore into stems; wind, hail, etc., injure young parts of trees, and in fact small wounds are formed in such quantities that if the fructifications of such fungi as those referred to are permitted to ripen indiscriminately, the wonder is not that access to the timber is gained, but rather that a tree of any considerable age escapes at all.

One of the commonest of these is *Polyporus sulphureus*, which does great injury to all kinds of standing timber, especially the oak, poplar, willow, hazel, pear, larch, and others. It is probably well known to all foresters, as its fructification projects horizontally from the diseased trunks as tiers of bracket-shaped bodies of a cheese-like consistency; bright yellow below, where the numerous minute pores are, and orange or somewhat vermilion above, giving the substance a coral-like appearance. I have often seen it in the neighborhood of Englefield Green and Windsor, and it is very common in England generally.

If the spore of this *Polyporus* lodges on a wound which exposes the cambium and young wood, the filaments grow into the medullary rays and the vessels and soon spread in all directions in the timber, especially longitudinally, causing the latter to assume a warm brown color and to undergo decay. In the infested timber are to be observed radial and other crevices filled with the dense felt-like mycelium formed by the common growth of the innumerable branched filaments. In bad cases it is possible to strip sheets of this yellowish white felt work out of the cracks, and on looking at the timber more closely (of the oak, for instance), the vessels are found to be filled with the fungus filaments, and look like long white streaks in longitudinal sections of the wood—showing as white dots in transverse sections.

It is not necessary to dwell on the details of the histology of the diseased timber; the ultimate filaments of the fungus penetrate the walls of all the cells and vessels, dissolve and destroy the starch in the medullary rays, and convert the lignified walls of the wood elements back again into cellulose. This evidently occurs by some solvent action, and is due to a ferment excreted from the fungus filaments, and the destroyed timber becomes reduced to a brown mass of powder.

I cannot leave this subject without referring to a remarkably interesting museum specimen which Prof. Hartig showed and explained to me last summer. This is a block of wood containing an enormous irregularly spheroidal mass of the white felted mycelium of this fungus, *Polyporus sulphureus*. The mass had been cut clean across, and the section exposed a number of thin brown ovoid bodies embedded in the closely woven felt; these bodies were of the size and shape of acorns, but were simply hollow shells filled with the same felt-like mycelium as that in which they were embedded. They were cut in all directions, and so appeared as circles in some cases. These bodies are, in fact, the outer shells of so many acorns, embedded in and hollowed out by the mycelium of *Polyporus sulphureus*. Hartig's ingenious explanation of their presence speaks for itself. A squirrel had stored up the acorns in a hollow in the timber, and had not returned to them—what tragedy intervenes must be left to the imagination. The *Polyporus* had then invaded the hollow, and the acorns, and had dissolved and destroyed the cellular and starchy contents of the latter, leaving only the cuticularized and corky shells, looking exactly like fossil eggs in the matrix. I hardly think geology can beat this for a true story.

The three diseases so far described serve very well as types of a number of others known to be due to the invasion of timber and the dissolution of the walls of its cells, fibers, and vessels by hymenomycetous fungi, *i.e.*, by fungi allied to the toadstools and polypores. They all "rot" the timber by destroying its structure and substance, starting from the cambium and medullary rays.

To mention one or two additional forms, *Trametes Pini* is common on pines, but, unlike its truly parasitic ally, *Tr. radiciperda*, which attacks sound roots, it is a wound parasite, and seems able to gain access to the timber only if the spores germinate on exposed surfaces. The disease it produces is very like that caused by its ally; probably none but an expert could distinguish between them, though the differences are clear when the histology is understood.

Polyporus fulvus is remarkable because its hyphæ destroy the middle lamella, and thus isolate the tracheides in the timber of firs; *Polyporus borealis* also produces disease in the timber of standing conifers; *Polyporus igniarius* is one of the commonest parasites on trees such as the oak, etc., and produces in them a disease not unlike that due to the last form mentioned; *Polyporus dryadeus* also destroys oaks, and is again remarkable because its hyphæ destroy the middle lamella.

With reference to the two fungi last mentioned I cannot avoid describing a specimen in the Museum of Forest Botany in Munich, since it seems to have a possible bearing on a very important question of biology, *viz.*, the action of soluble ferments.

It has already been stated that some of these tree-killing fungi excrete ferments which attack and dissolve starch grains, and it is well known that starch grains are stored up in the cells of the medullary rays found in timber. Now, *Polyporus dryadeus* and *P. igniarius* are such fungi; their hyphæ excrete a ferment which completely destroys the starch grains in the cells of the medullary rays of the oak, a tree very apt to be attacked by these two parasites, though *P. igniarius*, at any rate, attacks many other dicotyledonous trees as well. It occasionally happens that an oak is attacked by both of these polyporei, and their mycelia become intermingled in the timber; when this is the case, the *starch grains remain intact in those cells which are invaded simultaneously by the hyphæ of both fungi*. Prof. Hartig lately showed me longitudinal radial sections of oak timber thus attacked, and the medullary rays showed up as glistening white plates. These plates consist of nearly pure starch; the hyphæ have destroyed the cell walls, but left the starch intact. It is easy to suggest that the two ferments acting together exert (with respect to the starch) a sort of inhibitory action one on the other; but it is also obvious that this is not the ultimate explanation, and one feels that the matter deserves investigation.

It now becomes a question—What other types of timber diseases shall be described? Of course the limits of a popular article are too narrow for anything approaching an exhaustive treatment of such a subject, and nothing has as yet been said of several other diseases due to crust-like fungi often found on decaying stems, or of others due to certain minute fungi which attack healthy roots. Then there is a class of diseases which commence in the bark or cortex of trees, and extend thence into the cambium and timber: some of these "cankers," as they are often called, are proved to be due to the ravages of fungi, though there is another series of apparently similar "cankers" which are caused by variations in the environment—the atmosphere and weather generally.

It would need a long article to place the reader *au courant* with the chief results of what is known of these diseases, and I must be content here with the bare statement that these "cankers" are in the main due to local injury or destruction of the cambium. If the normal cylindrical sheet of cambium is locally irritated or destroyed, no one can wonder that the thickening layers of wood are not continued normally at the locality in question; the uninjured cells are also influenced, and abnormal cushions of tissue formed, which vary in different cases. Now, in "cankers" this is—

put shortly—what happens: it may be, and often is, due to the local action of a parasitic fungus; or it may be, and, again, often is, owing to injuries produced by the weather, in the broad sense, and saprophytic organisms may subsequently invade the wounds.

The details as to how the injury thus set up is propagated to other parts—how the "canker" spreads into the bark and wood around—*are* details, and would require considerable space for their description: the chief point here is again the destructive action of mycelia of various fungi, which by means of their powers of pervading the cells and vessels of the wood, and of secreting soluble ferments which break down the structure of the timber, render the latter diseased and unfit for use. The only too well known larch disease is a case in point; but since this is a subject which needs a chapter to itself, I may pass on to more general remarks on what we have learned so far.

It will be noticed that, whereas such fungi as *Trametes radiciperda* and *Agaricus melleus* are true parasites which can attack the living roots of trees, the other fungi referred to can only reach the interior of the timber from the exposed surfaces of wounds. It has been pointed out along what lines the special treatment of the former diseases must be followed, and it only remains to say of the latter: take care of the cortex and cambium of the tree, and the timber will take care of itself. It is unquestionably true that the diseases due to wound parasites can be avoided if no open wounds are allowed to exist. Many a fine oak and beech perishes before its time, or its timber becomes diseased and a high wind blows the tree down, because the spores of one of these fungi alight on the cut or torn surface of a pruned or broken branch. Of course it is not always possible to carry out the surgical operations, so to speak, which are necessary to protect a tree which has lost a limb, and in other cases no doubt those responsible have to discuss whether it costs more to perform the operations on a large scale than to risk the timber. With these matters I have nothing to do here, but the fact remains that by properly closing over open wounds, and allowing the surrounding cambium to cover them up, as it will naturally do, the term of life of many a valuable tree can be prolonged, and its timber not only prevented from becoming diseased and deteriorating, but actually increased in value.

There is no need probably for me to repeat that, although the present essay deals with certain diseases of timber due to fungi, there are other diseases brought about entirely by inorganic agencies. Some of these were touched upon in the last article, and I have already put before the readers of *Nature* some remarks as to how trees and their timber may suffer from the roots being in an unsuitable medium.

In the next paper it is proposed to deal with the so-called "dry rot" in timber which has been felled and cut up—a disease which has produced much distress at various times and in various countries.

[\[1\]](#)

Continued from SUPPLEMENT, No, 640, p. 10222.

THE SCIENTIFIC AMERICAN

Architects and Builders Edition

\$2.50 a Year. Single Copies, 25 cts.

This is a Special Edition of the SCIENTIFIC AMERICAN, issued monthly—on the first day of the month. Each number contains about forty large quarto pages, equal to about two hundred ordinary book pages, forming, practically, a large and splendid **Magazine of Architecture**, richly adorned with *elegant plates in colors* and with, fine engravings, illustrating the most interesting examples of modern Architectural Construction and allied subjects.

A special feature is the presentation in each number of a variety of the latest and best plans for private residences, city and country, including those of very moderate cost as well as the more expensive. Drawings in perspective and in color are given, together with full Plans, Specifications, Costs, Bills of Estimate, and Sheets of Details.

No other building paper contains so many plans, details, and specifications regularly presented as the SCIENTIFIC AMERICAN. Hundreds of dwellings have already been erected on the various plans we have issued during the past year, and many others are in process of construction.

Architects, Builders, and Owners will find this work valuable in furnishing fresh and useful suggestions. All who contemplate building or improving homes, or erecting

structures of any kind, have before them in this work an almost *endless series of the latest and best examples* from which to make selections, thus saving time and money.

Many other subjects, including Sewerage, Piping, Lighting, Warming, Ventilating, Decorating, Laying out of Grounds, etc., are illustrated. An extensive Compendium of Manufacturers' Announcements is also given, in which the most reliable and approved Building Materials, Goods, Machines, Tools, and Appliances are described and illustrated, with addresses of the makers, etc.

The fullness, richness, cheapness, and convenience of this work have won for it the **Largest Circulation** of any Architectural publication in the world.

MUNN & CO., Publishers,

361 Broadway, New York.

A Catalogue of valuable books on Architecture, Building, Carpentry, Masonry, Heating, Warming, Lighting, Ventilation, and all branches of industry pertaining to the art of Building, is supplied free of charge, sent to any address.

Building Plans and Specifications.

In connection with the publication of the BUILDING EDITION of the SCIENTIFIC AMERICAN, Messrs. Munn & Co. furnish plans and specifications for buildings of every kind, including Churches, Schools, Stores, Dwellings, Carriage Houses, Barns, etc.

In this work they are assisted by able and experienced architects. Full plans, details, and specifications for the various buildings illustrated in this paper can be supplied.

Those who contemplate building, or who wish to alter, improve, extend, or add to existing buildings, whether wings, porches, bay windows, or attic rooms, are invited to communicate with the undersigned. Our work extends to all parts of the country. Estimates, plans, and drawings promptly prepared. Terms moderate. Address

MUNN & CO., 361 BROADWAY, NEW YORK.

The

Scientific American Supplement.

PUBLISHED WEEKLY

Terms of Subscription, \$5 a year.

Sent by mail, postage prepaid, to subscribers in any part of the United States or Canada. Six dollars a year, sent, prepaid, to any foreign country.

All the back numbers of THE SUPPLEMENT, from the commencement, January 1, 1876, can be had. Price, 10 cents each.

All the back volumes of THE SUPPLEMENT can likewise be supplied. Two volumes are issued yearly.

Price of each volume, \$2.50 stitched in paper, or \$3.50 bound in stiff covers.

COMBINED RATES.—One copy of SCIENTIFIC AMERICAN and one copy of SCIENTIFIC AMERICAN SUPPLEMENT, one year, postpaid, \$7.00.

A liberal discount to booksellers, news agents, and canvassers.

MUNN & CO., Publishers,
361 Broadway, New York, N.Y.

PATENTS.

In connection with the **Scientific American**, Messrs. MUNN & Co. are solicitors of American and Foreign Patents, have had 42 years' experience, and now have the largest establishment in the world. Patents are obtained on the best terms.

A special notice is made in the **Scientific American**, of all inventions patented through this Agency, with the name and residence of the Patentee. By the immense circulation thus given, public attention is directed to the merits of the new patent,

and sales or introduction often easily effected.

Any person who has made a new discovery or invention can ascertain, free of charge, whether a patent can probably be obtained, by writing to MUNN & Co.

We also send free our Hand Book about the Patent Laws, Patents, Caveats, Trade Marks, their costs, and how procured. Address

**MUNN & CO.,
361 Broadway, New York.**

Branch Office, 622 and 624 F St., Washington, D.C.

*** END OF THE PROJECT GUTENBERG EBOOK SCIENTIFIC AMERICAN
SUPPLEMENT, NO. 643, APRIL 28, 1888 ***

Updated editions will replace the previous one—the old editions will be renamed.

Creating the works from print editions not protected by U.S. copyright law means that no one owns a United States copyright in these works, so the Foundation (and you!) can copy and distribute it in the United States without permission and without paying copyright royalties. Special rules, set forth in the General Terms of Use part of this license, apply to copying and distributing Project Gutenberg™ electronic works to protect the PROJECT GUTENBERG™ concept and trademark. Project Gutenberg is a registered trademark, and may not be used if you charge for an eBook, except by following the terms of the trademark license, including paying royalties for use of the Project Gutenberg trademark. If you do not charge anything for copies of this eBook, complying with the trademark license is very easy. You may use this eBook for nearly any purpose such as creation of derivative works, reports, performances and research. Project Gutenberg eBooks may be modified and printed and given away—you may do practically ANYTHING in the United States with eBooks not protected by U.S. copyright law. Redistribution is subject to the trademark license, especially commercial redistribution.

START: FULL LICENSE
THE FULL PROJECT GUTENBERG LICENSE
PLEASE READ THIS BEFORE YOU DISTRIBUTE OR USE THIS WORK

To protect the Project Gutenberg™ mission of promoting the free distribution of electronic works, by using or distributing this work (or any other work associated in any way with the phrase “Project Gutenberg”), you agree to comply with all the terms of the Full Project Gutenberg™ License available with this file or online at www.gutenberg.org/license.

Section 1. General Terms of Use and Redistributing Project Gutenberg™ electronic works

1.A. By reading or using any part of this Project Gutenberg™ electronic work, you indicate that you have read, understand, agree to and accept all the terms of this license and intellectual property (trademark/copyright) agreement. If you do not agree to abide by all the terms of this agreement, you must cease using and return or destroy all copies of Project Gutenberg™ electronic works in your possession. If you paid a fee for obtaining a copy of or access to a Project Gutenberg™ electronic work and you do not agree to be bound by the terms of this agreement, you may obtain a refund from the person or entity to whom you paid the fee as set forth in paragraph 1.E.8.

1.B. “Project Gutenberg” is a registered trademark. It may only be used on or associated in any way with an electronic work by people who agree to be bound by the terms of this agreement. There are a few things that you can do with most Project Gutenberg™ electronic works even without complying with the full terms of this agreement. See paragraph 1.C below. There are a lot of things you can do with Project Gutenberg™ electronic works if you follow the terms of this agreement and help preserve free future access to Project Gutenberg™ electronic works. See paragraph 1.E below.

1.C. The Project Gutenberg Literary Archive Foundation (“the Foundation” or PGLAF), owns a compilation copyright in the collection of Project Gutenberg™ electronic works. Nearly all the individual works in the collection are in the public domain in the United States. If an individual work is unprotected by copyright law in the United States and you are located in the United States, we do not claim a right to prevent you from copying, distributing, performing,

displaying or creating derivative works based on the work as long as all references to Project Gutenberg are removed. Of course, we hope that you will support the Project Gutenberg™ mission of promoting free access to electronic works by freely sharing Project Gutenberg™ works in compliance with the terms of this agreement for keeping the Project Gutenberg™ name associated with the work. You can easily comply with the terms of this agreement by keeping this work in the same format with its attached full Project Gutenberg™ License when you share it without charge with others.

1.D. The copyright laws of the place where you are located also govern what you can do with this work. Copyright laws in most countries are in a constant state of change. If you are outside the United States, check the laws of your country in addition to the terms of this agreement before downloading, copying, displaying, performing, distributing or creating derivative works based on this work or any other Project Gutenberg™ work. The Foundation makes no representations concerning the copyright status of any work in any country other than the United States.

1.E. Unless you have removed all references to Project Gutenberg:

1.E.1. The following sentence, with active links to, or other immediate access to, the full Project Gutenberg™ License must appear prominently whenever any copy of a Project Gutenberg™ work (any work on which the phrase “Project Gutenberg” appears, or with which the phrase “Project Gutenberg” is associated) is accessed, displayed, performed, viewed, copied or distributed:

This eBook is for the use of anyone anywhere in the United States and most other parts of the world at no cost and with almost no restrictions whatsoever. You may copy it, give it away or re-use it under the terms of the Project Gutenberg License included with this eBook or online at www.gutenberg.org. If you are not located in the United States, you will have to check the laws of the country where you are located before using this eBook.

1.E.2. If an individual Project Gutenberg™ electronic work is derived from texts not protected by U.S. copyright law (does not contain a notice indicating that it is posted with permission of the copyright holder), the work can be copied and distributed to anyone in the United States without paying any fees or charges. If you are redistributing or providing access to a work with the phrase “Project Gutenberg” associated with or appearing on the work, you must comply either with the requirements of paragraphs 1.E.1 through 1.E.7 or obtain permission for the use of the work and the Project Gutenberg™ trademark as set forth in paragraphs 1.E.8 or 1.E.9.

1.E.3. If an individual Project Gutenberg™ electronic work is posted with the permission of the copyright holder, your use and distribution must comply with both paragraphs 1.E.1 through 1.E.7 and any additional terms imposed by the copyright holder. Additional terms will be linked to the Project Gutenberg™ License for all works posted with the permission of the copyright holder found at the beginning of this work.

1.E.4. Do not unlink or detach or remove the full Project Gutenberg™ License terms from this work, or any files containing a part of this work or any other work associated with Project Gutenberg™.

1.E.5. Do not copy, display, perform, distribute or redistribute this electronic work, or any part of this electronic work, without prominently displaying the sentence set forth in paragraph 1.E.1 with active links or immediate access to the full terms of the Project Gutenberg™ License.

1.E.6. You may convert to and distribute this work in any binary, compressed, marked up, nonproprietary or proprietary form, including any word processing or hypertext form. However, if you provide access to or distribute copies of a Project Gutenberg™ work in a format other than “Plain Vanilla ASCII” or other format used in the official version posted on the official Project Gutenberg™ website (www.gutenberg.org), you must, at no additional cost, fee or expense to the user, provide a copy, a means of exporting a copy, or a means of obtaining a copy upon request, of the work in its original “Plain Vanilla ASCII” or other form. Any alternate format must include the full Project Gutenberg™ License as specified in paragraph 1.E.1.

1.E.7. Do not charge a fee for access to, viewing, displaying, performing, copying or distributing any Project Gutenberg™ works unless you comply with paragraph 1.E.8 or 1.E.9.

1.E.8. You may charge a reasonable fee for copies of or providing access to or

distributing Project Gutenberg™ electronic works provided that:

- You pay a royalty fee of 20% of the gross profits you derive from the use of Project Gutenberg™ works calculated using the method you already use to calculate your applicable taxes. The fee is owed to the owner of the Project Gutenberg™ trademark, but he has agreed to donate royalties under this paragraph to the Project Gutenberg Literary Archive Foundation. Royalty payments must be paid within 60 days following each date on which you prepare (or are legally required to prepare) your periodic tax returns. Royalty payments should be clearly marked as such and sent to the Project Gutenberg Literary Archive Foundation at the address specified in Section 4, "Information about donations to the Project Gutenberg Literary Archive Foundation."
- You provide a full refund of any money paid by a user who notifies you in writing (or by e-mail) within 30 days of receipt that s/he does not agree to the terms of the full Project Gutenberg™ License. You must require such a user to return or destroy all copies of the works possessed in a physical medium and discontinue all use of and all access to other copies of Project Gutenberg™ works.
- You provide, in accordance with paragraph 1.F.3, a full refund of any money paid for a work or a replacement copy, if a defect in the electronic work is discovered and reported to you within 90 days of receipt of the work.
- You comply with all other terms of this agreement for free distribution of Project Gutenberg™ works.

1.E.9. If you wish to charge a fee or distribute a Project Gutenberg™ electronic work or group of works on different terms than are set forth in this agreement, you must obtain permission in writing from the Project Gutenberg Literary Archive Foundation, the manager of the Project Gutenberg™ trademark. Contact the Foundation as set forth in Section 3 below.

1.F.

1.F.1. Project Gutenberg volunteers and employees expend considerable effort to identify, do copyright research on, transcribe and proofread works not protected by U.S. copyright law in creating the Project Gutenberg™ collection. Despite these efforts, Project Gutenberg™ electronic works, and the medium on which they may be stored, may contain "Defects," such as, but not limited to, incomplete, inaccurate or corrupt data, transcription errors, a copyright or other intellectual property infringement, a defective or damaged disk or other medium, a computer virus, or computer codes that damage or cannot be read by your equipment.

1.F.2. LIMITED WARRANTY, DISCLAIMER OF DAMAGES - Except for the "Right of Replacement or Refund" described in paragraph 1.F.3, the Project Gutenberg Literary Archive Foundation, the owner of the Project Gutenberg™ trademark, and any other party distributing a Project Gutenberg™ electronic work under this agreement, disclaim all liability to you for damages, costs and expenses, including legal fees. YOU AGREE THAT YOU HAVE NO REMEDIES FOR NEGLIGENCE, STRICT LIABILITY, BREACH OF WARRANTY OR BREACH OF CONTRACT EXCEPT THOSE PROVIDED IN PARAGRAPH 1.F.3. YOU AGREE THAT THE FOUNDATION, THE TRADEMARK OWNER, AND ANY DISTRIBUTOR UNDER THIS AGREEMENT WILL NOT BE LIABLE TO YOU FOR ACTUAL, DIRECT, INDIRECT, CONSEQUENTIAL, PUNITIVE OR INCIDENTAL DAMAGES EVEN IF YOU GIVE NOTICE OF THE POSSIBILITY OF SUCH DAMAGE.

1.F.3. LIMITED RIGHT OF REPLACEMENT OR REFUND - If you discover a defect in this electronic work within 90 days of receiving it, you can receive a refund of the money (if any) you paid for it by sending a written explanation to the person you received the work from. If you received the work on a physical medium, you must return the medium with your written explanation. The person or entity that provided you with the defective work may elect to provide a replacement copy in lieu of a refund. If you received the work electronically, the person or entity providing it to you may choose to give you a second opportunity to receive the work electronically in lieu of a refund. If the second copy is also defective, you may demand a refund in writing without further opportunities to fix the problem.

1.F.4. Except for the limited right of replacement or refund set forth in paragraph 1.F.3, this work is provided to you 'AS-IS', WITH NO OTHER WARRANTIES OF ANY KIND, EXPRESS OR IMPLIED, INCLUDING BUT NOT LIMITED TO WARRANTIES OF MERCHANTABILITY OR FITNESS FOR ANY PURPOSE.

1.F.5. Some states do not allow disclaimers of certain implied warranties or the exclusion or limitation of certain types of damages. If any disclaimer or limitation set forth in this agreement violates the law of the state applicable to this agreement, the agreement shall be interpreted to make the maximum disclaimer or limitation permitted by the applicable state law. The invalidity or unenforceability of any provision of this agreement shall not void the remaining provisions.

1.F.6. INDEMNITY - You agree to indemnify and hold the Foundation, the trademark owner, any agent or employee of the Foundation, anyone providing copies of Project Gutenberg™ electronic works in accordance with this agreement, and any volunteers associated with the production, promotion and distribution of Project Gutenberg™ electronic works, harmless from all liability, costs and expenses, including legal fees, that arise directly or indirectly from any of the following which you do or cause to occur: (a) distribution of this or any Project Gutenberg™ work, (b) alteration, modification, or additions or deletions to any Project Gutenberg™ work, and (c) any Defect you cause.

Section 2. Information about the Mission of Project Gutenberg™

Project Gutenberg™ is synonymous with the free distribution of electronic works in formats readable by the widest variety of computers including obsolete, old, middle-aged and new computers. It exists because of the efforts of hundreds of volunteers and donations from people in all walks of life.

Volunteers and financial support to provide volunteers with the assistance they need are critical to reaching Project Gutenberg™'s goals and ensuring that the Project Gutenberg™ collection will remain freely available for generations to come. In 2001, the Project Gutenberg Literary Archive Foundation was created to provide a secure and permanent future for Project Gutenberg™ and future generations. To learn more about the Project Gutenberg Literary Archive Foundation and how your efforts and donations can help, see Sections 3 and 4 and the Foundation information page at www.gutenberg.org.

Section 3. Information about the Project Gutenberg Literary Archive Foundation

The Project Gutenberg Literary Archive Foundation is a non-profit 501(c)(3) educational corporation organized under the laws of the state of Mississippi and granted tax exempt status by the Internal Revenue Service. The Foundation's EIN or federal tax identification number is 64-6221541. Contributions to the Project Gutenberg Literary Archive Foundation are tax deductible to the full extent permitted by U.S. federal laws and your state's laws.

The Foundation's business office is located at 809 North 1500 West, Salt Lake City, UT 84116, (801) 596-1887. Email contact links and up to date contact information can be found at the Foundation's website and official page at www.gutenberg.org/contact

Section 4. Information about Donations to the Project Gutenberg Literary Archive Foundation

Project Gutenberg™ depends upon and cannot survive without widespread public support and donations to carry out its mission of increasing the number of public domain and licensed works that can be freely distributed in machine-readable form accessible by the widest array of equipment including outdated equipment. Many small donations (\$1 to \$5,000) are particularly important to maintaining tax exempt status with the IRS.

The Foundation is committed to complying with the laws regulating charities and charitable donations in all 50 states of the United States. Compliance requirements are not uniform and it takes a considerable effort, much paperwork and many fees to meet and keep up with these requirements. We do not solicit donations in locations where we have not received written confirmation of compliance. To SEND DONATIONS or determine the status of compliance for any particular state visit www.gutenberg.org/donate.

While we cannot and do not solicit contributions from states where we have not met the solicitation requirements, we know of no prohibition against accepting unsolicited donations from donors in such states who approach us with offers to donate.

International donations are gratefully accepted, but we cannot make any statements concerning tax treatment of donations received from outside the United States. U.S. laws alone swamp our small staff.

Please check the Project Gutenberg web pages for current donation methods and addresses. Donations are accepted in a number of other ways including checks, online payments and credit card donations. To donate, please visit:
www.gutenberg.org/donate

Section 5. General Information About Project Gutenberg™ electronic works

Professor Michael S. Hart was the originator of the Project Gutenberg™ concept of a library of electronic works that could be freely shared with anyone. For forty years, he produced and distributed Project Gutenberg™ eBooks with only a loose network of volunteer support.

Project Gutenberg™ eBooks are often created from several printed editions, all of which are confirmed as not protected by copyright in the U.S. unless a copyright notice is included. Thus, we do not necessarily keep eBooks in compliance with any particular paper edition.

Most people start at our website which has the main PG search facility:
www.gutenberg.org.

This website includes information about Project Gutenberg™, including how to make donations to the Project Gutenberg Literary Archive Foundation, how to help produce our new eBooks, and how to subscribe to our email newsletter to hear about new eBooks.