

The Project Gutenberg eBook of Pressure, Resistance, and Stability of Earth, by J. C. Meem

This ebook is for the use of anyone anywhere in the United States and most other parts of the world at no cost and with almost no restrictions whatsoever. You may copy it, give it away or re-use it under the terms of the Project Gutenberg License included with this ebook or online at www.gutenberg.org. If you are not located in the United States, you'll have to check the laws of the country where you are located before using this eBook.

Title: Pressure, Resistance, and Stability of Earth

Author: J. C. Meem

Release date: October 25, 2005 [EBook #16938]
Most recently updated: December 12, 2020

Language: English

Credits: Produced by Juliet Sutherland, Taavi Kalju and the Online Distributed Proofreading Team at <https://www.pgdp.net>

*** START OF THE PROJECT GUTENBERG EBOOK PRESSURE, RESISTANCE, AND STABILITY OF EARTH ***

Pg 352

AMERICAN SOCIETY OF CIVIL ENGINEERS

INSTITUTED 1852

TRANSACTIONS

Paper No. 1174

PRESSURE, RESISTANCE, AND STABILITY OF EARTH. ^[A]

BY J.C. MEEM, M. AM. SOC. C. E.

WITH DISCUSSION BY MESSRS. T. KENNARD THOMSON, CHARLES E. GREGORY, FRANCIS W. PERRY, E.P. GOODRICH, FRANCIS L. PRUYN, FRANK H. CARTER, AND J.C. MEEM.

In the final discussion of the writer's paper, "The Bracing of Trenches and Tunnels, With Practical Formulas for Earth Pressures,"^[B] certain minor experiments were noted in connection with the arching properties of sand. In the present paper it is proposed to take up again the question of earth pressures, but in more detail, and to note some further experiments and deductions therefrom, and also to consider the resistance and stability of earth as applied to piling and foundations, and the pressure on and buoyancy of subaqueous structures in soft ground.

In order to make this paper complete in itself, it will be necessary, in some instances, to include in substance some of the matter of the former paper, and indulgence is asked from those readers who may note this fact.

SECTIONS OF BOX-FRAME FOR SAND-ARCH EXPERIMENT

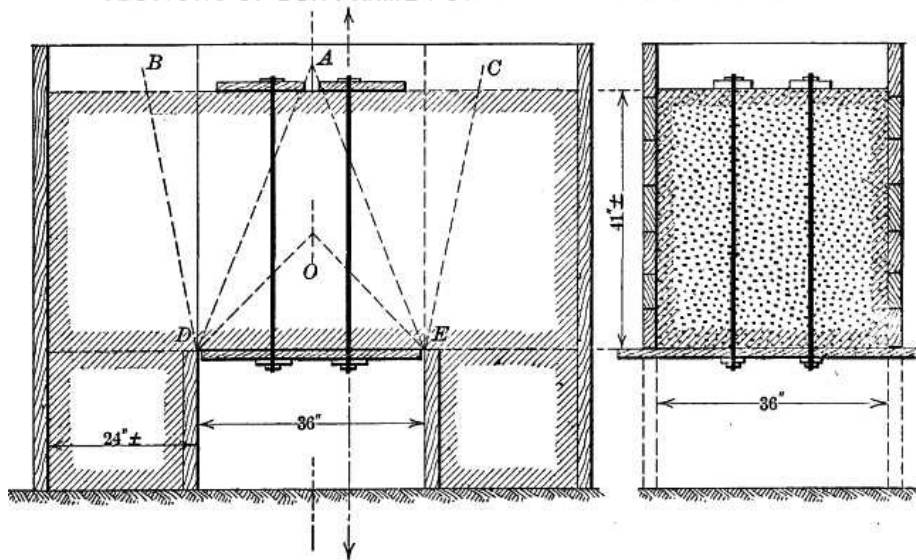

FIG. 1.

Pg 353

Experiment No. 1.—As the sand-box experiments described in the former paper were on a small scale, exception might be taken to them, and therefore the writer has made this experiment on a scale sufficiently large to be much more conclusive. As shown in [Fig. 1](#), wooden abutments, 3 ft. wide, 3 ft. apart, and about 1 ft. high, were built and filled solidly with sand. Wooden walls, 3 ft. apart and 4 ft. high, were then built crossing the abutments, and solidly cleated and braced frames were placed across their ends about 2 ft. back of each abutment. A false bottom, made to slide freely up and down between the abutments, and projecting slightly beyond the walls on each side, was then blocked up snugly to the bottom edges of the sides, thus obtaining a box 3 by 4 by 7 ft., the last dimension not being important. Bolts, 44 in. long, with long threads, were run up through the false bottom and through 6 by 15 by 2-in. pine washers to nuts on the top. The box was filled with ordinary coarse sand from the trench, the sand being compacted as thoroughly as possible. The ends were tightened down on the washers, which in turn bore on the compacted sand. The blocking was then knocked out from under the false bottom, and the following was noted:

Pg 354

As soon as the blocking was removed the bottom settled nearly 2 in., as noted in [Fig. 1, Plate XXIV](#), due to the initial compacting of the sand under the arching stresses. A measurement was taken from the bottom of the washers to the top of the false bottom, and it was noted as 41 in. ([Fig. 1](#)). After some three or four hours, as the arch had not been broken, it was decided to test it under greater loading, and four men were placed on it, four others standing on the haunches, as shown in [Fig. 2, Plate XXIV](#). Under this additional loading of about 600 lb. the bottom settled 2 in. more, or nearly 4 in. in all, due to the further compression of the sand arch. About an hour after the superimposed load had been removed, the writer jostled the box with his foot sufficiently to dislodge some of the exposed sand, when the arch at once collapsed and the bottom fell to the ground.

Referring to [Fig. 2](#), if, instead of being ordinary sand, the block comprised within the area, $A U J V X$, had been frozen sand, there can be no reason to suppose that it would not have sustained itself, forming a perfect arch, with all material removed below the line, $V E J$, in fact, the freezing process of tunneling in soft ground is based on this well-known principle.

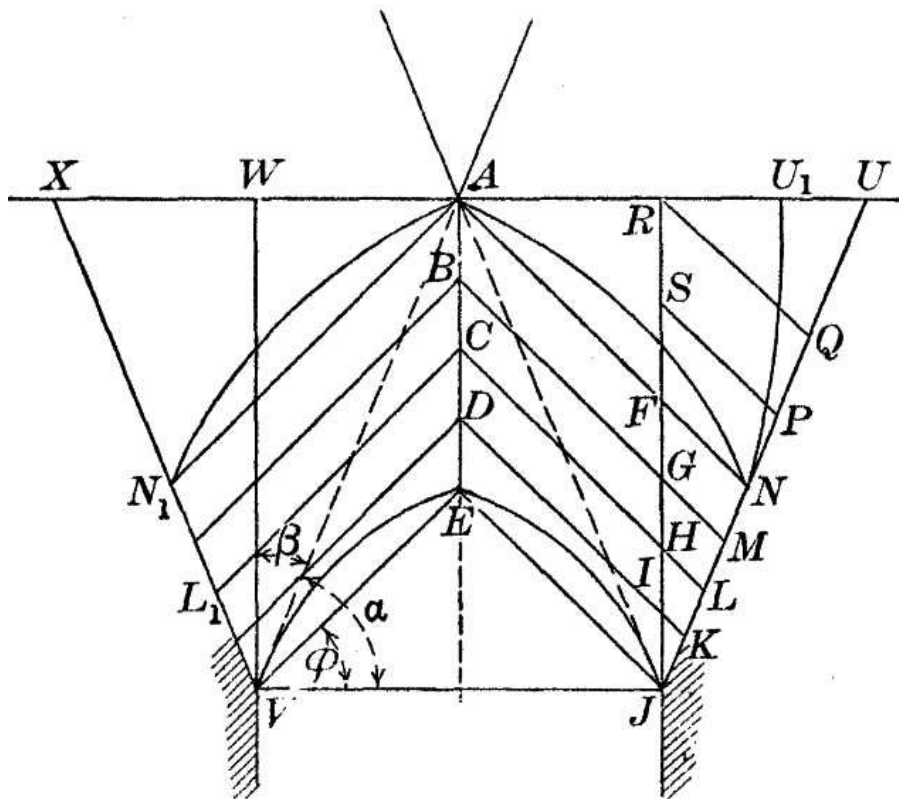

FIG. 2.

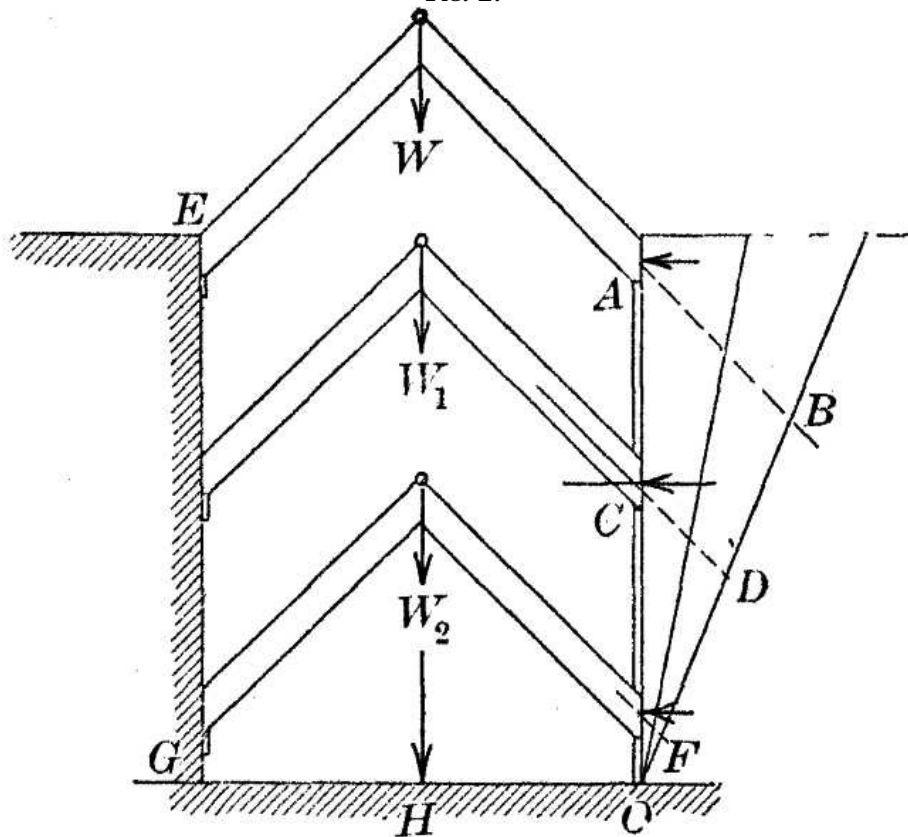

FIG. 3.

If, then, instead of removing the mass, $J E V$, it is allowed to remain and is supported from the mass above, one must concede to this mass in its normal state the same arching properties it would have had if frozen, excepting, of course, that a greater thickness of key should be allowed, to offset a greater tendency to compression in moist and dry as against frozen sand, where both are measured in a confined area.

If, in [Fig. 2](#), $E V J = \phi =$ the angle of repose, and it be assumed that $A J$, the line bisecting the angle between that of repose and the perpendicular, measures at its intersection with the middle vertical (A , [Fig. 2](#)) the height which is necessary to give a sufficient thickness of key, it may be concluded that this sand arch will be self-sustaining. That is, it is assumed that the arching effect is taken up virtually within the limits of the area, $A N_1 V E J N A$, thus relieving the structure below of the stresses due to the weight or thrust of any of the material above; and that the portion of the material below $V E J$ is probably dead weight on any structure underneath, and when sustained from below forms a natural "centering" for the natural arch above. It is also probably true that the material in the areas, $X N_1 A$ and $A N U$, does not add to the arching strength, more especially in those materials where cohesion may not be counted on as a factor. This is borne out by the fact that, in the experiment noted, a well-defined crack developed on the surface of the sand at about the point U_1 , and extended apparently a considerable depth, assumed to be

at *N*, where the haunch line is intersected by the slope line from *A*.

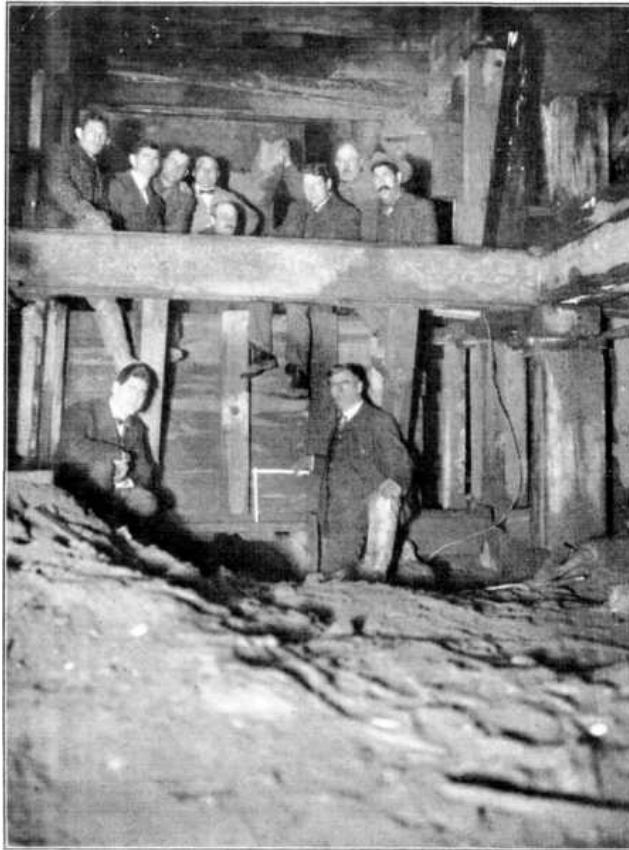

PLATE XXIV, FIG. 1.—INITIAL SETTLEMENT IN 3-FT. SAND ARCH, DUE TO COMPRESSION OF MATERIAL ON REMOVING SUPPORTS FROM BOTTOM.

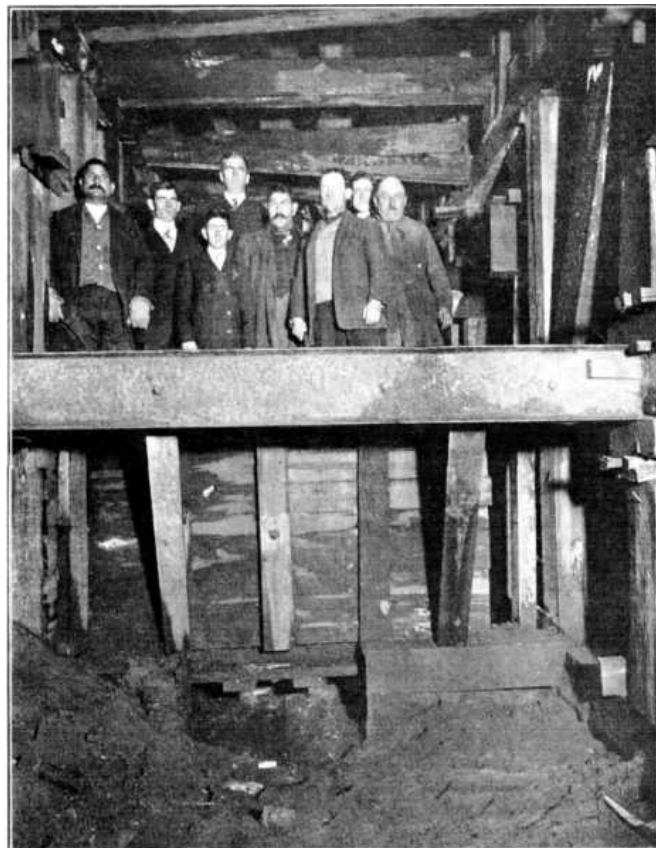

PLATE XXIV, FIG. 2.—FINAL SETTLEMENT OF SAND ARCH, DUE TO COMPRESSION IN EXCESS LOADING.

In this experiment the sand was good and sharp, containing some gravel, and was taken directly from the adjoining excavation. When thrown loosely in a heap, it assumed an angle of repose of about 45 degrees. It should be noted that this material when tested was not compacted as much, nor did it possess the same cohesion, as sand in its normal undisturbed condition in a bank, and for this reason it is believed that the depth of key given here is absolutely safe for all except extraordinary conditions, such as non-homogeneous material and others which may require special consideration.

Referring again to the area, $A N_1 V J N A$, [Fig. 2](#), it is probable that, while self-sustaining, some at least of the lower portion must derive its initial support from the "centering" below, and the writer has made the arbitrary assumption that the lower half of it is carried by the structure while the upper half is entirely independent of it, and, in making this assumption, he believes he is adding a factor of safety thereto. The area, then, which is assumed to be carried by an underground structure the depth of which is sufficient to

allow the lines, $V A$ and $J A$, to intersect below the surface, is the lower half of $A N_1 V E J N A$, or its equivalent, $A V E J A$, plus the area, $V E J$, or $A V J A$, the angle, $A V J$, being

$$\alpha = \frac{1}{2}(90^\circ - \phi) + \phi = 45^\circ + \frac{\phi}{2}.$$

It is not probable that these lines of thrust or pressure transmission, $A N, D K$, etc., will be straight, but, for purposes of calculation, they will be assumed to be so; also, that they will act along and parallel to the lines of repose of their natural slope, and that the thrust of the earth will therefore be measured by the relation between the radius and the tangent of this angle multiplied by the weight of material affected. The dead weight on a plane, $V J$, due to the material above, is, therefore, where

l = span or extreme width of opening = $V J$,
 W = weight per cubic foot of material, and
 W_1 = weight per linear foot.

$$W_1 = \frac{2 \times \frac{l}{2} \tan \alpha \times W}{2} = \frac{1}{2} l \tan \left\{ \frac{1}{2}(90^\circ - \phi) + \phi \right\} W = \frac{l}{2} \tan \left(45^\circ + \frac{\phi}{2} \right) W.$$

The application of the above to flat-arched or circular tunnels is very simple, except that the question of side thrust should be considered also as a factor. The thrust against the side of a tunnel in dry sand having a flat angle of repose will necessarily be greater than in very moist sand or clay, which stands at a much steeper angle, and, for the same reason, the arch thrust is greater in dryer sand and therefore the load on a tunnel structure should not be as great, the material being compact and excluding cohesion as a factor. This can be illustrated by referring to [Fig. 3](#) in which it is seen that the flatter the position of the "rakers" keying at W_1, W_2 , and W , the greater will be the side thrust at A, C , and F . It can also be illustrated by assuming that the arching material is composed of cubes of polished marble set one vertically above the other in close columns. There would then be absolutely no side thrust, but, likewise, no arching properties would be developed, and an indefinite height would probably be reached above the tunnel roof before friction enough would be developed to cause it to relieve the structure of any part of its load. Conversely, if it be assumed that the superadjacent material is composed of large bowling balls, interlocking with some degree of regularity, it can be seen that those above will form themselves into an arch over the "centering" made up of those supported directly by the roof of the structure, thus relieving the structure of any load except that due to this "centering."

If, now, the line, $A B$, in [Fig. 4](#), be drawn so as to form with $A C$ the angle, β , to be noted later, and it be assumed that it measures the area of pressure against $A C$, and if the line, $C F$, be drawn, forming with $C G$, the angle, α , noted above, then $G F$ can be reduced in some measure by reason of the increase of $G C$ to $C B$, because the side thrust above the line, $B C$, has slightly diminished the loading above. The writer makes the arbitrary assumption that this decrease in $G F$ should equal 20% of $B C = F D_1$. If, then, the line, $B D_1$ be drawn, it is conceded that all the material within the area, $A B D_1 G C A$, causes direct pressure against or upon the structure, $G C A$, the vertical lines being the ordinates of pressure due to weight, and the horizontal lines (qualified by certain ratios) being the abscissas of pressure due to thrust. An extreme measurement of this area of pressure is doubtless approximately more nearly a curve than the straight lines given, and the curve, $A R T I D_{II}$, is therefore drawn in to give graphically and approximately the safe area of which any vertical ordinate, multiplied by the weight, gives the pressure on the roof at that point, and any horizontal line, or abscissa, divided by the tangent of the angle of repose and multiplied by the weight per foot, gives the pressure on the side at that point.

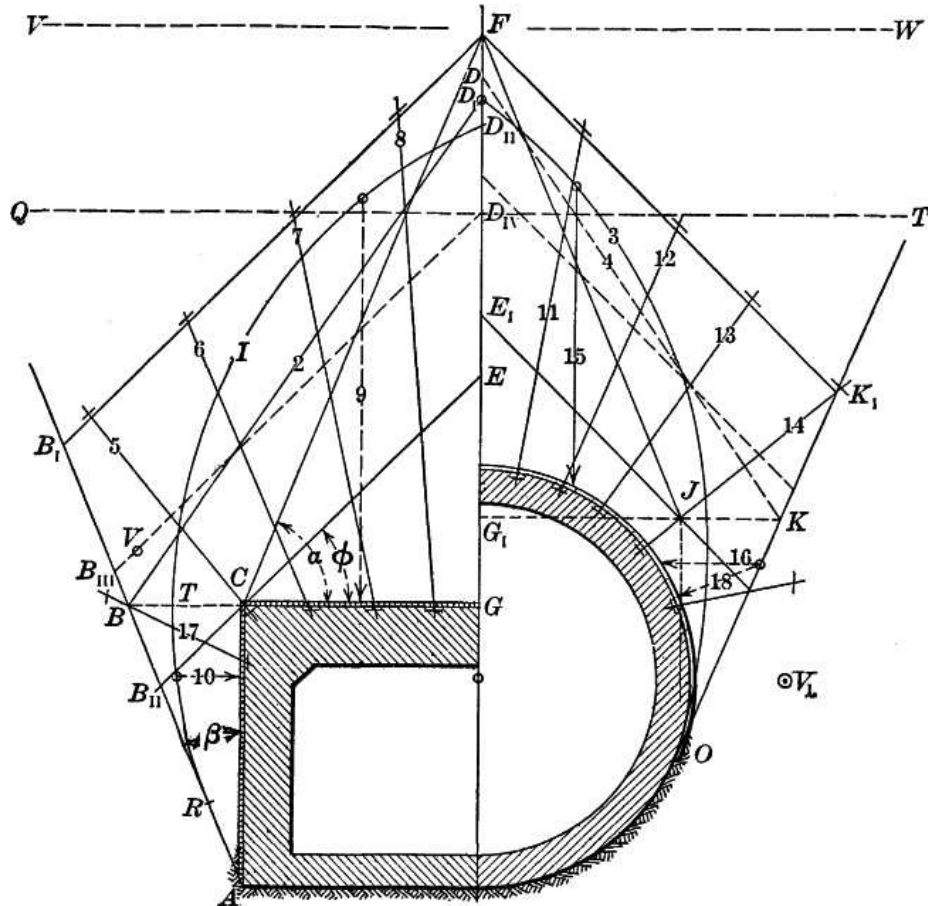

FIG. 4.

The practical conclusion of this whole assumption is that the material in the area, $F E C B B_1$, forms with the equivalent opposite area an arch reacting against the face, $C B B_1$ and that, as heretofore noted, the lower half (or its equivalent, $B D_1 G B$) of the weight of this is assumed to be carried by the structure, the upper half being self-sustaining, as shown by the line, $B_{III} D_{IV}$ (or, for absolute safety, the curved line), and therefore, if rods could be run from sheeting inside the tunnel area to a point outside the line, $F B_1$, as indicated by the lines, 5, 6, 7, 8, 11, 12, 13, etc., that the internal bracing of this tunnel could be omitted, or that the tunnel itself would be relieved of all loading, whereas these rods would be carrying some large portion at least of the weight within the area circumscribed by the curve, $D_{II} I T G$, and further, that a tunnel structure of the approximate dimensions shown would carry its maximum load with the surface of the ground between D_{IV} and F , beyond which point the pressure would remain the same for all depths.

In calculating pressures on circular arches, the arched area should first be graphically resolved into a rectangular equivalent, as in the right half of Fig. 4, proceeding subsequently as noted.

The following instances are given as partial evidence that in ordinary ground, not submerged, the pressures do not exceed in any instance those found by the above methods, and it is very probable that similar instances or experiences have been met by every engineer engaged in soft-ground tunneling:

In building the Bay Ridge tunnel sewer, in 62d and 64th Streets, Brooklyn, the arch timber bracing shown in Fig. 1, Plate XXVI, was used for more than 4,000 ft., or for two-thirds of the whole 5,800 ft. called for in the contract. The external width of opening, measured at the wall-plate, averaged about 19 ft. for the 14½-ft. circular sewer and 19½ ft. for the 15-ft. sewer. The arch timber segments in the cross-section were 10 by 12-in. North Carolina pine of good grade, with 2 in. off the butt for a bearing to take up the thrust. They were set 5 ft. apart on centers, and rested on 6 by 12-in. wall-plates of the same material as noted above. The ultimate strength of this material, across the grain, when dry and in good condition, as given by the United States Forestry Department tests is about 1,000 lb. in compression. Some tests^[C] made in 1907 by Mr. E.F. Sherman for the Charles River Dam in Boston, Mass., show that in yellow pine, which had been water-soaked for two years, checks began to open at from 388 to 581 lb. per sq. in., and that yields of ¼ in. were noted at from 600 to 1,000 lb. As the tunnel wall-plates described in this paper were subject to occasional saturation, and always to a moist atmosphere, they could never have been considered as equal to dry material. Had the full loading shown by the foregoing come on these wall-plates, they would have been subjected to a stress of about 25 tons each, or nearly one-half of their ultimate strength. In only one or two instances, covering stretches of 100 ft. in one case and 200 ft. in another, where there were large areas of quicksand sufficient to cause semi-aqueous pressure, or pockets of the same material causing eccentric loading, did these wall-plates show any signs of heavy pressure, and in many instances they were in such good condition that they could be taken out and used a second and a third time. Two especially interesting instances came under the writer's observation: In one case, due to a collapse of the internal bracing, the load of an entire section, 25 ft. long and 19 ft. wide, was carried for several hours on ribs spaced 5 ft. apart. The minimum cross-section of these ribs was 73 sq. in., and they were under a stress, as noted above, of 50,000 lb., or nearly up to the actual limit of strength of the wall-plate where the rib bore on it. When these wall-plates were examined, after replacing the internal bracing, they did not appear to have been under any unusual stress.



PLATE XXV, FIG. 1.—NORMAL SLOPES AND STRATA OF NEWLY EXCAVATED BANKS.



PLATE XXV, FIG. 2.—NORMAL SLOPES AND STRATA OF NEWLY EXCAVATED BANKS.

In another instance, for a distance of more than 700 ft., the sub-grade of the sewer was 4 ft. below the level of the water in sharp sand. In excavating for "bottoms" the water had to be pumped at the rate of more than 300 gal. per min., and it was necessary to close-sheet a trench between the wall-plates in which to place a section of "bottom." In spite of the utmost care, some ground was necessarily lost, and this was shown by the slight subsidence of the wall-plates and a loosening up of the wedges in the supports bearing on the arch timbers. During this operation of "bottoming," two men on each side were constantly employed in tightening up wedges and shims above the arch timbers. It is impossible to explain the fact that these timbers slackened (without proportionate roof settlement) by any other theory than that the arching was so nearly perfect that it relieved the bracing of a large part of the load, the ordinary loose material being held in place by the arching or wedging together of the 2-in. by 3-ft. sheeting boards in the roof, arranged in the form of a segmental arch. The material above this roof was coarse, sharp sand, through which it had been difficult to tunnel without losing ground, and it had admitted water freely after each rain until the drainage of a neighboring pond had been completed, the men never being willing to resume work until the influx of water had stopped.

The foregoing applies only to material ordinarily found under ground not subaqueous, or which cannot be classed as aqueous or semi-aqueous material. These conditions will be noted later.

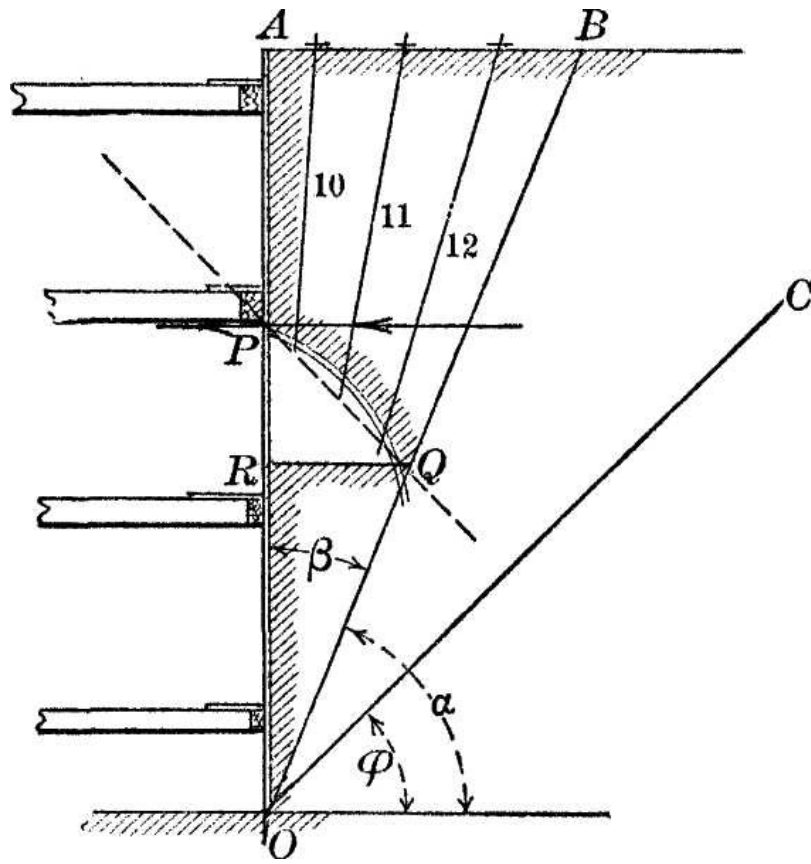

FIG. 5.

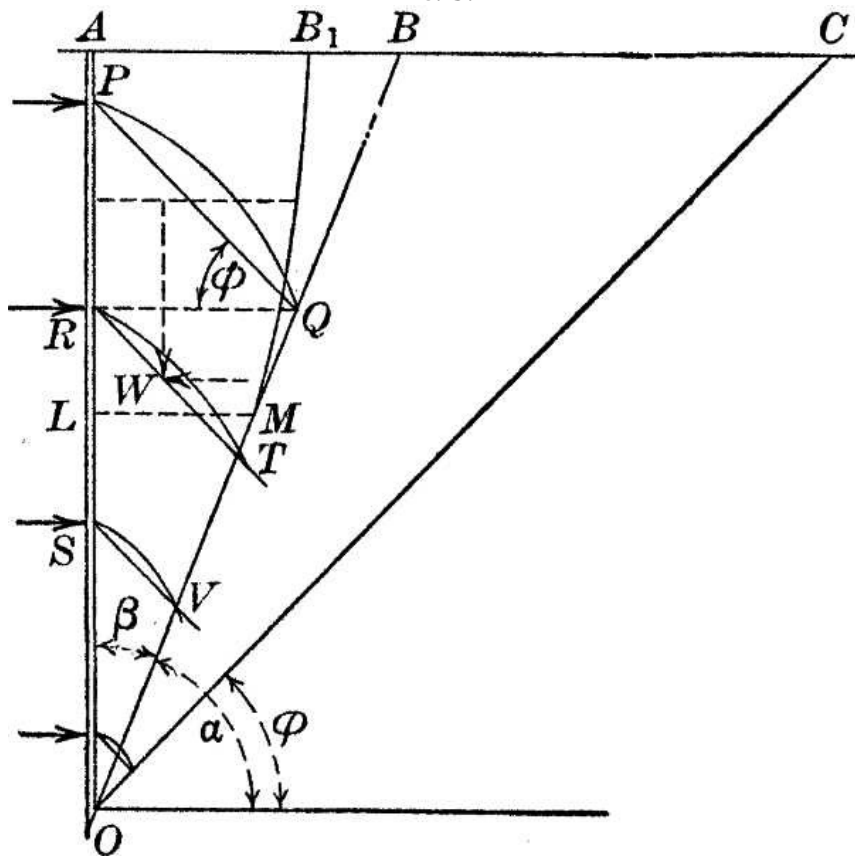

FIG. 6.

The writer will take up next the question of pressures against the faces of sheeted trenches or retaining walls, in material of the same character as noted above. Referring to [Fig. 2](#), it is not reasonable to suppose that having passed the line, *R F J*, the character of the stresses due to the thrust of the material will change, if bracing should be substituted for the material in the area, *W V J R*, or if, as in [Fig. 3](#), canvas is rolled down along the lines, *E G* and *A O*, and if, as this section is excavated between the canvas faces, temporary struts are erected, there is no reason to believe that with properly adjusted weights at *W* or *W₂*, an exact equilibrium of forces and conditions cannot be obtained. Or, again, if, as in [Fig. 5](#), the face, *P Q*, is sheeted and rodded back to the surface, keying the rods taut, there is undoubtedly a stable condition and one which could not fail in theory or practice, nor can anyone, looking at [Fig. 5](#), doubt that the top timbers are stressed more heavily than those at the bottom. The assumption is that the tendency of the material to slide toward the toe causes it to wedge itself between the face of the sheeting on the one hand and some plane between the sheeting and the plane of repose on the other, and that the resistance to this tendency will cause an arching thrust to be developed along or parallel to the lines, *A N*, *B M*, etc., [Fig. 2](#), which are assumed to be the lines of repose, or curves approximating thereto. As the

thrust is greatest in that material directly at the face, $A O$, Fig. 6, and is nothing at the plane of repose, $C O$, it may be assumed arbitrarily that the line, $B O$, bisecting this angle divides this area into two, in one of which the weight resolves itself wholly into thrust, the other being an area of no thrust, or wholly of weight bearing on the plane of repose. Calling this line, $B O$, the haunch line, the thrust in the area, $A O B$, is measured by its weight divided by the tangent of the angle, $P Q R = \phi$, which is the angle of repose; that is, the thrust at any given point, $R = R Q \div \tan. \phi$.

The writer suggests that, in those materials which have steeper angles of repose than 45° , the area of pressure may be calculated as above, the thrust being computed, however, as for an angle of 45 degrees.

In calculating the bending moment against a wall or bracing, there is the weight of the mass multiplied by the distance of its center of gravity vertically above the toe, or, approximately:

Area, $A O B \times$ weight per unit $\times \frac{2}{3}$ height,

where $h =$ height,

$$W = \text{weight per cubic foot of material} = 90 \text{ lb.}, \text{ and } \beta = \frac{90^\circ - \phi}{2}$$

$P =$ pressure per linear foot (vertically),

$$\text{then } P = h \times \frac{h}{2} (\tan \beta) \times W \times \frac{2}{3} h = \frac{1}{3} h^3 W \tan \beta.$$

When the angle of repose, ϕ , is less than 45° , this result must be reduced by dividing by $\tan. \phi$; that is, $h = \frac{1}{3} h^3 \tan. \beta \div \tan. \phi$.

Figs. 1 and 2, Plate XXV, show recently excavated banks of gravel and sand, which, standing at a general angle of 45° , were in process of "working," that is, there was continual slipping down of particles of the sand, and it may be well to note that in time, under exposure to weather conditions, these banks would finally assume a slope of about 33 degrees. They are typical, however, as showing the normal slope of freshly excavated sandy material, and a slope which may be used in ordinary calculations. The steps seen in Plate XXV show the different characteristics of ground in close proximity. In Fig. 2, Plate XXVI,^[D] may be seen a typical bank of gravel and sand; it shows the well-defined slope of sand adjacent to and in connection with the cohesive properties of gravel.

Pg 362

The next points to be considered are the more difficult problems concerning subaqueous or saturated earths. The writer has made some experiments which appear to be conclusive, showing that, except in pure quicksand or wholly aqueous material, as described later, the earth and water pressures act independently of each other.

For a better understanding of the scope and purpose of this paper, the writer divides supersaturated or subaqueous materials into three classes:

Class A.—Firm materials, such as coarse and fine gravels, gravel and sands mixed, coarse sands, and fine sands in which there is not a large proportion of fine material, such as loam, clay, or pure quicksand.

Class B.—Semi-aqueous materials, such as fine sands in which there is a large proportion of clay, etc., pure clays, silts, peats, etc.

Class C.—Aqueous materials, such as pure quicksands, in which the solid matter is so finely divided that it is amorphous and virtually held in suspension, oils, quicksilver, etc.

Here it may be stated that the term, "quicksand," is so illusive that a true definition of it is badly needed. Many engineers call quicksand any sand which flows under the influence of water in motion. The writer believes the term should be applied only to material so "soupy" that its properties are practically the same as water under static conditions, it being understood that any material may be unstable under the influence of water at sufficiently high velocities, and that it is with a static condition, or one approximately so, that this paper deals.

A clear understanding of the firm materials noted in Class A will lead to a better solution of problems dealing with those under Class B, as it is to this Class A that the experiments largely relate.

The experiments noted below were made with varying material, though the principal type used was a fine sand, under the conditions in which it is ordinarily found in excavations, with less than 40% voids and less than 10% of very fine material.

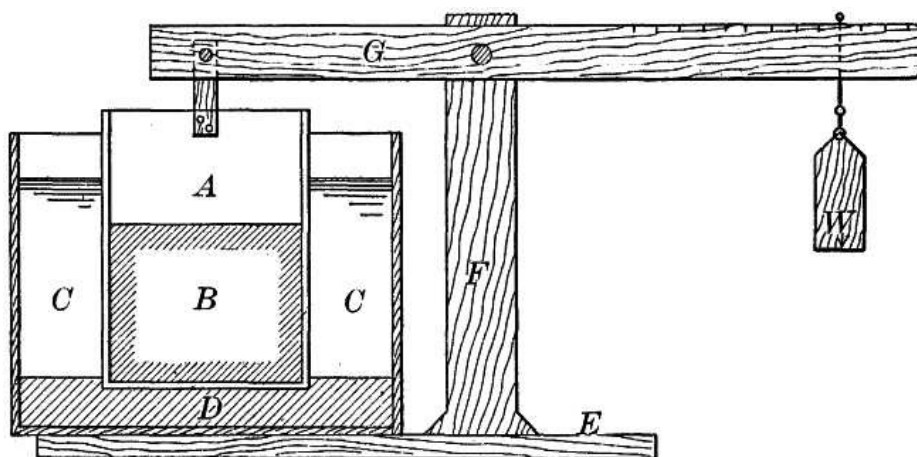

Experiment No. 2.—The first of these experiments, which in this series will be called No. 2, was simple, and was made in order to show that this material does not flow readily under ordinary conditions, when not coupled with the discharge of water under high velocity. A bucket 12 in. in diameter, containing another bucket 9 in. in diameter, was used. A 6 by 6-in. hole was cut in the bottom of the inner bucket. About 3 in. of sand was first placed in the bottom of the larger bucket and it was partly filled with water. The inside bucket was then given a false bottom and partly filled with wet sand, resting on the sand in the larger bucket. Both were filled with water, and the weight, *W*, Fig. 7, on the arm was shifted until it balanced the weight of the inside bucket in the water, the distance of the weight, *W*, from the pivot being noted. The false bottom was then removed and the inside bucket, resting on the sand in the larger one, was partly filled with sand and both were filled with water, the conditions at the point of weighing being exactly the same, except that the false bottom was removed, leaving the sand in contact through the 6 by 6-in. opening. It is readily seen that, if the sand had possessed the aqueous properties sometimes attributed to sand under water, that in the inside bucket would have flowed out through the square hole in the bottom, allowing it to be lifted by any weight in excess of the actual weight of the bucket, less its buoyancy, as would be the case if it contained only water instead of sand and water. It was found, however, that the weight, resting at a distance of more than nine-tenths of the original distance from the pivot, would not raise the inside bucket. On lifting this inside bucket bodily, however, the water at once forced the sand out through the bottom, leaving a hole almost exactly the shape and size of the bottom orifice, as shown in Fig. 1, Plate XXVII. It should be stated that, in each case, the sand was put in in small handfuls and thoroughly mixed with water, but not packed, and allowed to stand for some time before the experiments were tried, to insure the compactness of ordinary conditions. It is seen from Fig. 1, Plate XXVII, that the sand was stable enough to allow the bucket to be put on its side for the moment of being photographed, although it had been pulled out of the water a little less than 3 min.

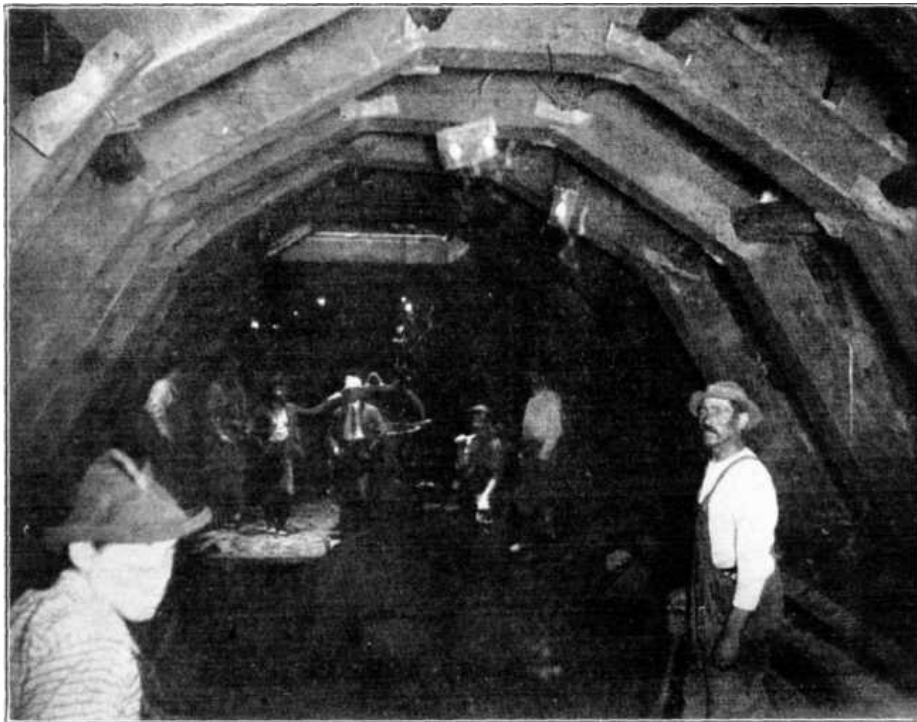

PLATE XXVI, FIG. 1.—TYPES OF ARCH TIMBERS USED IN BAY RIDGE TUNNEL SEWER.



PLATE XXVI, FIG. 2.—NORMAL SLOPE OF LOOSE SAND, GRAVEL, AND CEMENTED GRAVEL, IN CLOSE PROXIMITY.

Experiment No. 3.—In order to show that the arching properties of sand are not destroyed under subaqueous conditions, a small sand-box, having a capacity of about 1 cu. ft., and similar to that

described in Experiment No. 1, was made. The bottom was cut out, with the exception of a $\frac{3}{4}$ -in. projection on two sides, and a false bottom was placed below and outside of the original bottom, with bolts running through it, keying to washers on top of the sand, with which the box was partly filled. One side of the box contained a glass front, in order that conditions of saturation could be observed. The box of sand was then filled with water and, after saturation had been completed and the nuts and washers had been tightened down, the box was lifted off the floor. There was found to be no tendency whatever for the bottom to fall away, showing conclusively that the arching properties had not been destroyed by the saturation of the sand.

The next three experiments were intended to show the relative pressure over any given area in contact with the water in the one case or sand and water in the other.

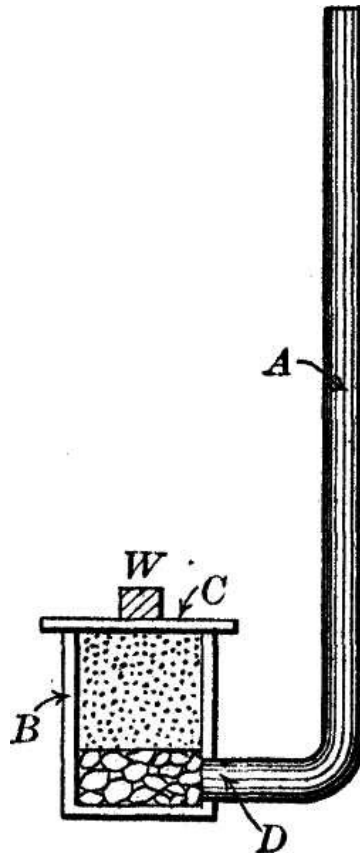

FIG. 8.

Experiment No. 4.—The apparatus for this experiment consisted of a 3-in. pipe about 4-in. long and connected with a $\frac{3}{4}$ -in. goose-neck pipe 17 in. high above the top of the bowl shown in Fig. 8 and in Fig. 2, Plate XXVII. A loose rubber valve was intended to be seated on the upper face of the machined edge of the bowl and weighted down sufficiently to balance it against a head of water corresponding to the 17-in. head in the goose-neck. The bowl was then to be filled with sand and the difference, if any, noted between the weight required to hold the flap-valve down under the same head of water flowing through the sand. The results of this experiment were not conclusive, owing to the difficulty of making contact over the whole area of the sand and the rim of the bowl at the same time. At times, for instance, less than 1 lb. would hold back the water indefinitely, while, again, 2 or 3 lb. would be required as opposed to the $4\frac{1}{2}$ lb. approximate pressure required to hold down the clear water. Again, at times the water would not flow through the neck at all, even after several hours, and after increasing the head by attaching a longer rubber tube thereto. In view of these conditions, this experiment would not be noted here, except that it unexpectedly developed one interesting fact. In order to insure against a stoppage of water, as above referred to, gravel was first put into the bottom of the bowl and the flap-valve was then rubbed down and held tightly while the pipe was filled. On being released, the pressure of water invariably forced out the whole body of sand, as shown in Fig. 2, Plate XXVII. Care was taken to see that the sand was saturated in each case, and the experiment was repeated numberless times, and invariably with the same result. The sand contained about 40% of voids. The deduction from this experiment is that the pressure of water is against rather than through sand and that any excess of voids occurring adjacent to a face against which there is pressure of water will be filled with sand, excepting in so far, of course, as the normal existing voids allow the pressure of the water to be transmitted through them.



PLATE XXVII, FIG. 1.—EXPERIMENT SHOWING PROPERTIES OF SAND.

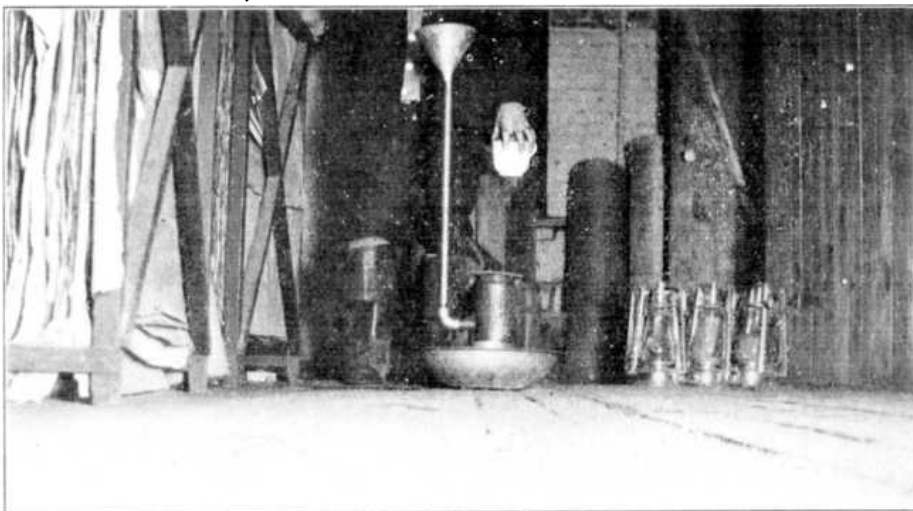

PLATE XXVII, FIG. 2.—SAND PUSHED UP FROM BOWL BY WATER PRESSURE THROUGH GOOSE-NECK.

If, then, the covering of sand over a structure is sufficiently heavy to allow arching action to be set up, the structure against which the pressure is applied must be relieved of much of the pressure of water against the area of sand not constituted as voids acting outside of the arching area. This is confirmed by the two following experiments:

Experiment No. 5.—The same apparatus was used here as in Experiment No. 2, [Fig. 7](#), except that the inside bucket had a solid bottom. The inside and outside buckets were filled with water and the point was noted at which the weight would balance the inside bucket at a point some 3 in. off the bottom of the outside bucket. This point was measured, and the bottom of the larger bucket was covered over with sand so that in setting solidly in the sand the inside bucket would occupy the same relative position as it did in the water. The same weight was then applied and would not begin to lift the inner bucket. For instance, in the first part of the experiment the weight stood at 12 in. from the pivot, while in the next step the weight, standing at the end of the bar, had no effect, and considerable external pressure had to be exerted before the bucket could be lifted. Immediately after it was relieved, however, the weight at 12 in. would hold it clear of the sand. No attempt was made to work the bucket into the sand; the sand was leveled up and the bucket was seated on it, turned once or twice to insure contact, and then allowed to stand for some time before making the experiment. No attempt was made to establish the relationship between sands of varying voids, the general fact only being established, by a sufficient number of experiments, that the weight required to lift the bucket was more than double in sand having 40% of voids than that required to lift the bucket in water only.

APPARATUS FOR MEASURING
LOSS OF WATER PRESSURE
IN SUBAQUEOUS MATERIAL

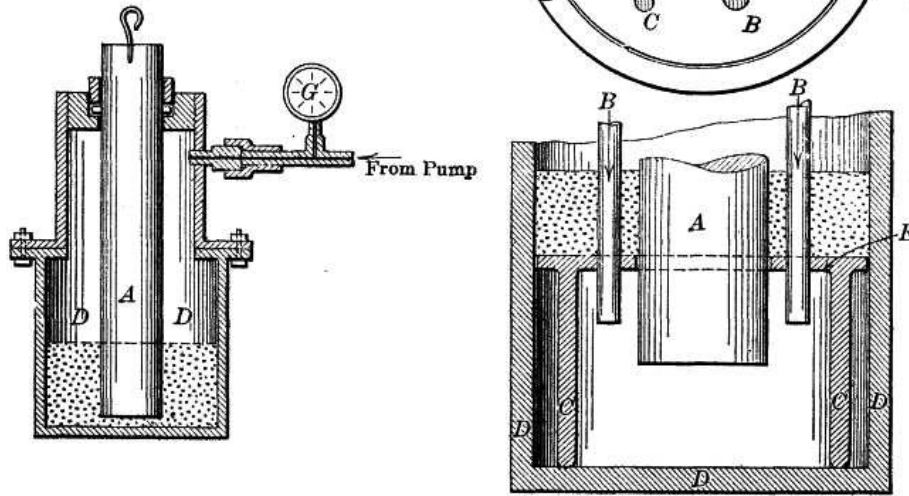

FIG. 9.

Experiment No. 6.—The apparatus for this experiment consisted essentially of a hydraulic chamber about 8 in. in diameter and 1 ft. high, the top being removable and containing a collar with suitable packing, through which a 2½-in. piston moved freely up and down, the whole being similar to the cylinder and piston of a large hydraulic jack, as shown in [Fig. 1, Plate XXVIII](#). Just below the collar and above the chamber there was a ½-in. inlet leading to a copper pipe and thence to a high-pressure pump. Attached to this there was a gauge to show the pressure obtained in the chamber, all as shown in [Fig. 9](#). The purpose of the apparatus was to test the difference in pressure on any object submerged in clear water and on the same object buried in the sand under water. It is readily seen that, if pressure be applied to the water in this chamber, the amount of pressure (as measured by the gauge) necessary to lift the piston will be that due to the weight of the piston, less its displacement, plus the friction of the piston in the collar.

Pg 367



PLATE XXVIII, FIG. 1.—APPARATUS FOR MEASURING LOSS OF PRESSURE IN SUBAQUEOUS MATERIALS.

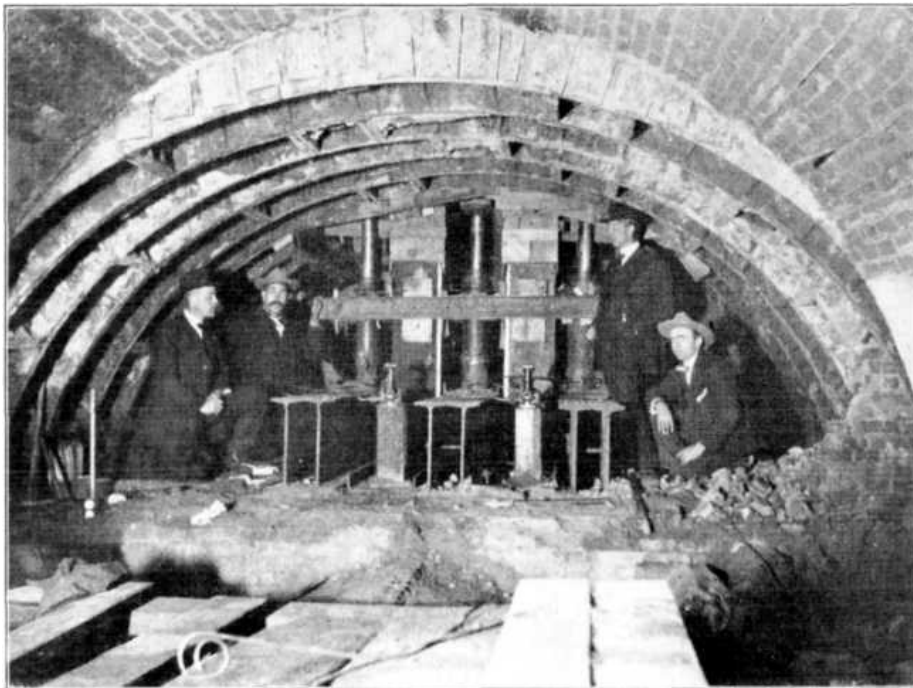

PLATE XXVIII, FIG. 2.—RAISING ROOF OF BATTERY TUBES, IN BROOKLYN, BY "BLEEDING" SAND THROUGH DISPLACED PLATES.

Now, if for any reason the bottom area of the piston against which the water pressure acts be reduced, it will necessarily require a proportionate amount of increase in the pressure to lift this piston. If, therefore, it is found that 10 lb., for illustration, be required to lift the piston when plunged in clear water, and 20 lb. be required to lift it when buried in sand, it can be assumed at once that the area of the piston has been reduced 50% by being buried in the sand, eliminating the question of the friction of the sand itself around the piston. In order to determine what this friction might be, the writer arranged a table standing on legs above the bottom of the chamber, allowing the piston to move freely through a hole in its center. Through this table pipes were entered (as shown in part of [Fig. 9](#)). The whole was then placed in the chamber with the piston in place, and the area above was filled with sand and water. It is thus seen that, the end of the piston being free and in clear water, the difference, if any, between the pressure required to lift the piston when in clear water alone and in the case thus noted, where it was surrounded by sand, would measure the friction of the sand on the piston. After several trials of this, however, it was clearly seen that the friction was too slight to be noted accurately by a gauge registering single pounds, that is, with a piston in contact with 6 in. of sand vertically, a friction of 25 lb. per sq. ft. would only require an increase of 1.8 lb. on the gauge. It is therefore assumed that the friction on so small a piston in sand need not be considered as a material factor in the experiments made.

The piston was plunged into clear water, and it was found that the pressure required to lift it was about 4 lb. The cap was then taken off, a depth of about 2 in. of sand was placed in the bottom of the chamber, and then the piston was set in place and surrounded by sand to a depth of some 6 in., water being added so that the sand was completely saturated. This was allowed to stand until it had regained the stability of ordinary sand in place, whereupon the cap with the collar bearing was set in place over the piston, the machine was coupled up, and the pump was started. A series of four experiments, extending over a period of two or three days, gave the following results:

Test 1.—The piston began to move at a pressure of 25 lb. The pressure gradually dropped to 7½ lb., at which point, apparently, it came out of the sand, and continued at 7½ lb. during the remainder of the test.

Test 2.—The piston was plunged back into the sand, without removing the cap, and allowed to stand for about 2 hours. No attempt was made to pack the sand or to see its condition around the piston, it being presumed, however, that it had reasonable time to get a fair amount of set. At slightly above 20 lb. the piston began to move, and as soon as a pocket of water accumulated behind the piston the pressure immediately dropped to 9 lb. and continued at this point until it came out of the sand.

Test 3.—The piston was plunged into the sand and hammered down without waiting for the sand to come to a definite set. In this case the initial pressure shown by the gauge was 17½ lb., which immediately dropped to 8 lb. as soon as the piston had moved sufficiently far to allow water to accumulate below it.

Test 4.—The cap was again removed, the piston set up in place, the sand compacted around it in approximately the same condition it would have had if the sand had been in place underground; the cap was then set in place and, after an hour, the pump was started. The pressure registered was 25 lb. and extended over a period of several seconds before there was any movement in the piston. The piston responded finally without any increase of pressure, and, after lifting an inch or two, the pressure gradually dropped to 10 lb., where it remained until the piston came out of the sand.

The sum and average of these tests shows a relation of 22 lb. for the piston in sand to about 8½ lb. as soon as the volume of water had accumulated below it, which would correspond very closely to a sand containing 40% of voids, which was the characteristic of the sand used in this experiment.

The conclusions from this experiment appear to be absolutely final in illustrating the pressure due to water on a tunnel buried in sand, either on the arch above or on the sides or bottom, as well as the buoyant effect upon the tunnel bottom under the same conditions.

While the apparatus would have to be designed and built on a much larger scale in order to measure accurately the pressures due to sands and earths of varying characteristics, it appears to be conclusive in

showing the principle, and near enough to the theoretical value to be taken for practical purposes in designing structures against water pressures when buried in sand or earth.

Pg 369

It should be carefully noted that the friction of the water through sand, which is always a large factor in subaqueous construction, is virtually eliminated here, as the water pressure has to be transmitted only some 6 or 8 in. to actuate the base of the piston, whereas in a tunnel only half submerged this distance might be as many feet, and would be a considerable factor.

It should be noted also that although the area subject to pressure is diminished, the pressure on the area remaining corresponds to the full hydrostatic head, as would be shown by the pressure on an air gauge required to hold back the water, except, of course, as it may be diminished more or less by friction.

The writer understands that experiments of a similar nature and with similar apparatus have been tried on clays and peats with results considerably higher; that is, in one case, there was a pressure of 40 lb. before the piston started to move.

The following is given, in part, as an analysis and explanation of the above experiments and notes:

It is well known that if lead be placed in a hydraulic press and subjected to a sufficient pressure it will exhibit properties somewhat similar to soft clay or quicksand under pressure. It will flow out of an orifice or more than one orifice at the same pressure. This is due to the fact that practically voids do not exist and that the pressure is so great, compared with the molecular cohesion, that the latter is virtually nullified. It is also theoretically true that solid stone under infinitely high pressure may be liquefied. If in the cylinder of a hydraulic press there be put a certain quantity of cobblestones, leaving a clearance between the top of the stone and the piston, and if this space, together with the voids, be filled with water and subjected to a great pressure, the sides or the walls of the cylinder are acted on by two pressures, one almost negligible, where they are in contact with the stone, restraining the tendency of the stone to roll or slide outward, and the other due to the pressure of the water over the area against which there is no contact of stone. That this area of contact should be deducted from the pressure area can be clearly shown by assuming another cylinder with cross-sticks jammed into it, as shown in [Fig. 10](#). A glance at this figure will show that there is no aqueous pressure on the walls of the cylinder with which the ends of the sticks come in contact and the loss of the pressure against the walls due to this is equal to the least sectional area of the stick or tube either at the point of contact or intermediate thereto.

Pg 370

Following this reasoning, in [Fig. 11](#) it is found that an equivalent area may be deducted covering the least area of continuous contact of the cobblestones, as shown along the dotted lines in the right half of the figure. Returning, if, when the pressure is applied, an orifice be made in the cylinder, the water will at once flow out under pressure, allowing the piston to come in contact with the cobblestones. If the flow of the water were controlled, so as to stop it at the point where the stone and water are both under direct pressure, it would be found that the pressures were totally independent of each other. The aqueous pressure, for instance, would be equal at every point, while the pressure on the stone would be through and along the lines of contact. If this contact was reasonably well made and covered 40% of the area, one would expect the stone, independently of the water, to stand 40% of the pressure which a full area of solid stone would stand. If this pressure should be enormously increased after excluding the water, it would finally result in crushing the stone into a solid mass; and if the pressure should be increased indefinitely, some theoretical point would be reached, as above noted, where the stone would eventually be liquefied and would assume liquid properties.

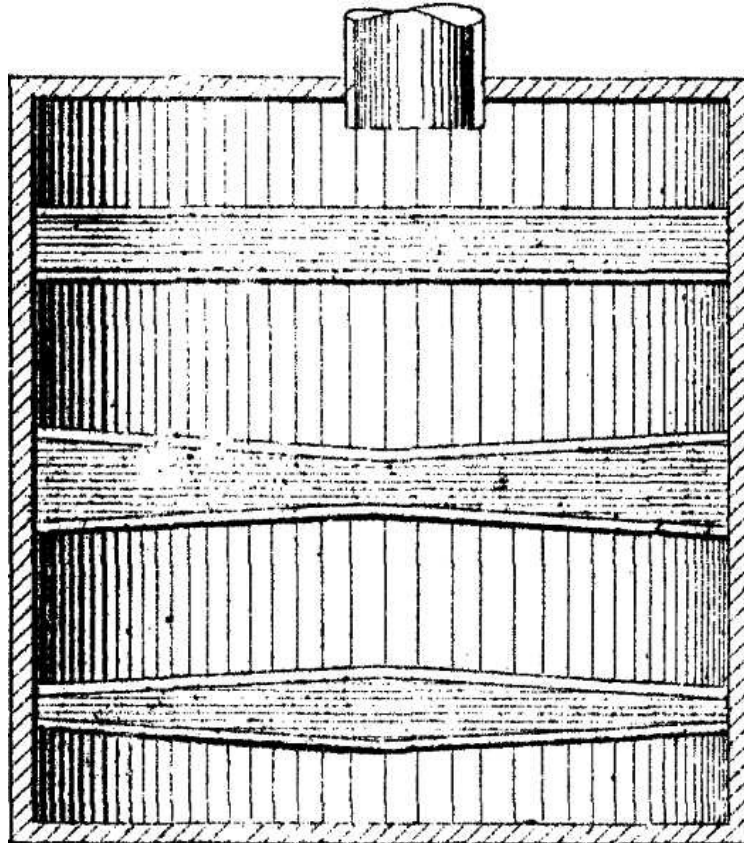

FIG. 10.

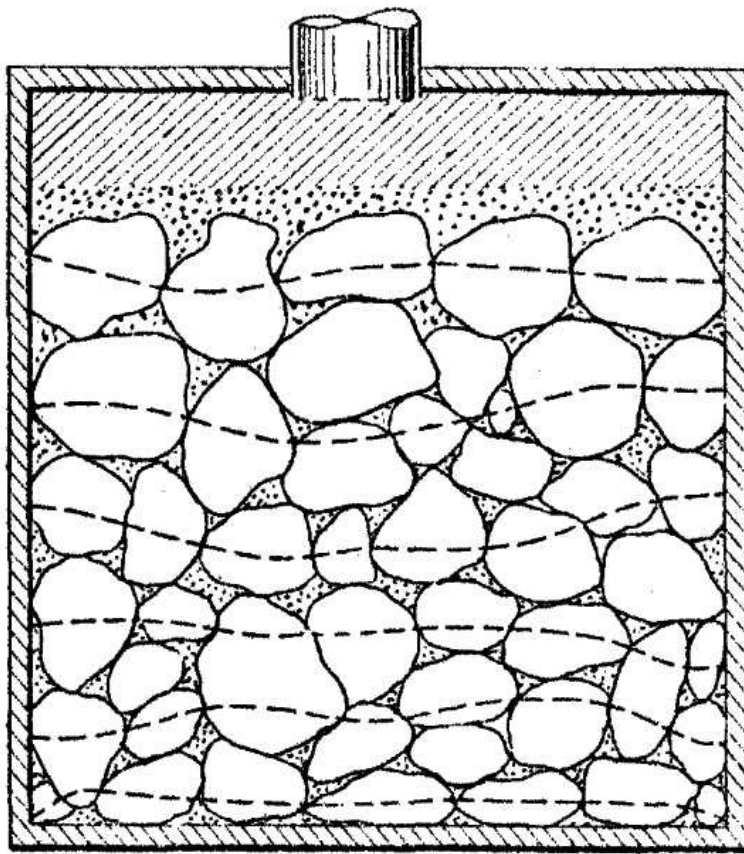

FIG. 11.

The same general reasoning applies to pure sand, sand being in effect cobblestones in miniature. In pressing the piston down on dry sand it will be displaced into every existing abnormal void, but will be displaced into these voids rather than pressed into them, in the true definition of the word, and while it would flow out of an orifice in the sides or bottom, allowing the piston to be forced down as in a sand-jack, it would not flow out of an orifice in the top of the piston, except under pressures so abnormally high as to make the mass theoretically aqueous. If the positions of cylinder and piston be reversed, the piston pointing vertically upward and the sand "bled" into an orifice in or through it, the void caused by the outflow of this sand would be filled by sand displaced by the piston pressing upward rather than by sand from above.

Pg 371

It was the knowledge of this principle which enabled the contractors to jack up successfully the roof of a long section of the cast-iron lined tubes under Joralemon Street in Brooklyn, in connection with the reconstruction of the Battery tubes at that point, the method of operation, as partly shown in [Fig. 2, Plate XXVIII](#), being to cut through a section of the roof, 4 by 10 ft. in area, through which holes were drilled and through which again the sand was "bled," heavy pressure being applied from below through the medium of hydraulic jacks. By a careful manipulation of both these operations, sections of the roof of the above dimensions were eventually raised the required height of 30 in. and permanently braced there in a single shift.

If water in excess be put into a cylinder containing sand, and pressure be applied thereto, the water, if allowed to flow out of an orifice, will carry with it a certain quantity of sand, according to the velocity, and the observation of this might easily give rise to the erroneous impression that the sand, as well as the water, was flowing out under pressure, and, as heretofore stated, has caused many engineers and contractors to apply the term "quicksand" to any sand flowing through an orifice with water.

Sand in its natural bed always contains some fine material, and where this is largely less than the percentage of voids, it has no material effect on the pressure exerted by the sand with or without water, as above noted. If, however, this fine material be largely in excess of the voids, it allows greater initial compression to take place when dry, and allows to be set up a certain amount of hydraulic action when saturated. If the base of the material be sand and the fill be so-called quicksand in excess of the voids, pressure will cause the quicksand to set up hydraulic action, and the action of the piston will appear to be similar to that of a piston acting on purely aqueous material.

Just here the writer desires to protest against considering semi-aqueous masses, such as soupy sands, soft concrete, etc., as exerting hydrostatic pressure due to their weight in bulk, instead of to the specific gravity of the basic liquid. For instance, resorting again to the illustration of cubes and spheres, it may be assumed that a cubical receptacle has been partly filled with small cubes of polished marble, piled vertically in columns. When this receptacle is filled with liquid around the piles of cubes there will be no pressure on the sides except that due to the hydrostatic pressure of the water at 62½ lb. The bottom, however, will resist a combined pressure due to the water and the weight of the cubes. Again, assume that the receptacle is filled with small spheres, such as marbles, and that water is then poured in. The pressure due to the weight of the solids on the bottom is relieved by the loss in weight of the marbles due to the water, and also to the tendency of the marbles to arch over the bottom, and while the pressure on the sides is increased by this amount of thrust, the aqueous pressure is still that of a liquid at 62½ lb., and it is inconceivable that some engineers, in calculating the thrust of aqueous masses, speak of it as a liquid weighing, say, 120 or 150 lb. per cu. ft.; as well might they expect to anchor spherical copper floats in front of a bulkhead and expect the hydrostatic pressure against this bulkhead to be diminished because the actual volume and weight of the water directly in front of the bulkhead has been diminished. Those who have had experience in tying narrow deep forms for concrete with small wires or bolts and quickly

Pg 372

filling them with liquid concrete, must realize that no such pressures are ever developed as would correspond to liquids of 150 lb. per cu. ft. If the solid material in any liquid is agitated, so that it is virtually in suspension, it cannot add to the pressure, and if allowed to subside it acts as a solid, independently of the water contained with it, although the water may change somewhat the properties of the material, by increasing or changing its cohesion, angle of repose, etc. That is, in substance, those particles which rest solidly on the bottom and are in contact to the top of the solid material, do not derive any buoyancy from the water, while those particles not in contact with the bottom directly or through other particles, lose just so much weight through buoyancy. If, then, the vertical depth of the earthy particles or sand above the bottom is so small that the arching effect against the sides is negligible, the full weight of the particles in contact, directly or vicariously, with the bottom acts as pressure on the bottom, while the full pressure of the water acts through the voids or on them, or is transmitted through material in contact with the bottom.

Pg 373

Referring now to materials such as clays, peats, and other soft or plastic materials, it is idle to assume that these do not possess pressure-resisting and arching properties. For instance, a soft clay arch of larger dimensions, under the condition described early in this paper, would undoubtedly stand if the rods supporting the intrados of the arch were keyed back to washers covering a sufficiently large area.

The fact that compressed air can be used at all in tunnel work is evidence that semi-aqueous materials have arching properties, and the fact that "blows" usually occur in light cover is further evidence of it.

When air pressure is used to hold back the water in faces of large area, bracing has to be resorted to. This again shows that while full hydrostatic pressure is required to hold back the water, the pressure of the earth is in a measure independent of it.

In a peaty or boggy material there is a condition somewhat different, but sufficiently allied to the soft clayey or soupy sands to place it under the same head in ordinary practice. It is undoubtedly true that piles can be driven to an indefinite depth in this material, and it is also true that the action of the pile is to displace rather than compress, as shown by the fact of driving portions of the tunnels under the North River for long distances without opening the doors of the shield or removing any of the material. The case of filling in bogs or marshes, causing them to sink at the point of filling and rise elsewhere, is readily explained by the fact that the water is confined in the interstices of the material, admitting of displacement but no compression.

The application of the above to pressures over tunnels in materials of Class A is that the sand or solid matter is virtually assumed to be a series of columns with their bases in such intimate contact with the tunnel roof that water cannot exert pressure on the tunnel or buoyancy on the sand at the point of contact, and that if these columns are sufficiently deep to have their upper portions wholly or partly carried by the arching or wedging action, the pressure of any water on their surfaces is not transferred to the tunnel, and the only aqueous pressure is that which acts on the tunnel between the assumed columns or through the voids.

Let l = exterior width of tunnel,
 d = depth of cover, as:

Pg 374

- D_W = depth, water to roof,
- D_E = " earth to roof,
- D_X = " of cover of earth necessary to arching stability,

that is:

$$D_X = \frac{l}{2} \left(\tan \left\{ \frac{90^\circ - \phi}{2} \right\} + \phi \right) = \frac{l}{2} \tan \left(45^\circ + \frac{\phi}{2} \right),$$

where ϕ = angle of repose,
 and $D_W > D_E > D_X$.

Then the pressure on any square foot of roof, as V_P as at the base of any vertical ordinate, as 9 in [Fig. 2](#),
 $= V_O$,

- W_E = weight per cubic foot of earth (90 lb.),
- W_W = " " " " " water (62½ lb.), we have

$$V_P = V_O \times W_E + D_W \times W_W \times 0.40 = V_O \times 90 + D_W \times 62\frac{1}{2} \times 0.4 = V_O \times 90 + D_W \times 25.$$

And for horizontal pressure:

P_h = the horizontal pressure at any abscissa (10), [Fig. 2](#), = A_{10} at depth of water D_{W1} is

$$P_h = \frac{A_{10} \times 90}{\tan \phi} + D_{W1} \times 62\frac{1}{2} \times 0.4 = \frac{A_{10} \times 90}{\tan \phi} + D_{W1} \times 25.$$

The only question of serious doubt is at just what depth the sand is incapable of arching itself, but, for purposes of safety, the writer has put this at the point, F , as noted above, = D_X , although he believes that experiments on a large scale would show it to be nearer $0.67 \cdot D_X$, above which the placing of additional back-fill will lighten the load on the structure.

We have, then, for $D_E < D_X$, the weight of the total prism of the earth plus the water in the voids, plus the added pressure of the water above the earth prism, that is:

The pressure per square foot at the base of any vertical ordinate = V_p

$$V_p = D_E \times 90 + D_E \times 62\frac{1}{2} \times 0.40 + (D_W - D_E) \times 62\frac{1}{2}.$$

To those who may contend that water acting through so shallow a prism of earth would exert full pressure over the full area of the tunnel, it may be stated that the water cannot maintain pressure over the whole area without likewise giving buoyancy to the sand previously assumed to be in columns, in which case there is the total weight of the water plus the weight of the prism of earth, less its buoyancy in water, that is

$$V_p = D_W \times 62\frac{1}{2} + D_E \times (90 - 62\frac{1}{2}),$$

Pg 375

which, by comparison with the former method, would appear to be less safe in its reasoning.

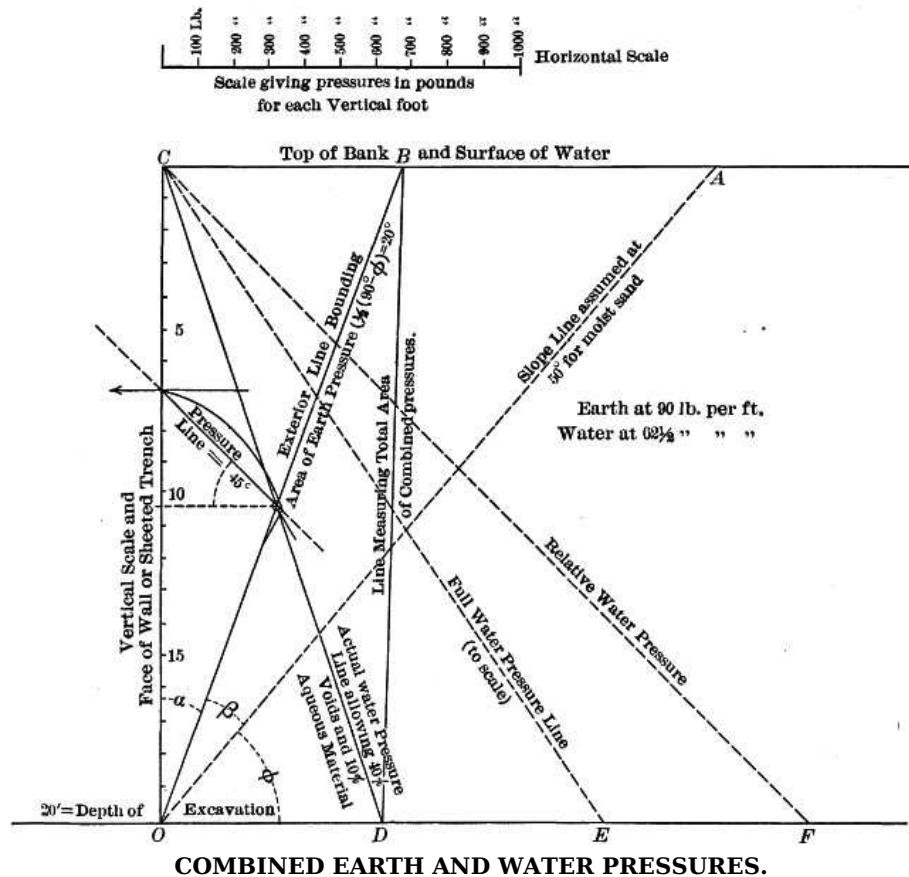

COMBINED EARTH AND WATER PRESSURES.

FIG. 12.

Next is the question of pressure against a wall or braced trench for materials under Class A. The pressure of sand is first calculated independently, as shown in Fig. 6. Reducing this to a basis of 100 lb. for each division of the scale measured horizontally, as shown, gives the line, BO , Fig. 12, measuring the outside limit of pressure due to the earth, the horizontal distance at any point between this line and the vertical face equalling the pressure against that face divided by the tangent of the angle of repose, which in this case is assumed to be 45° , equalling unity. If the water pressure line, CF , is drawn, it shows the relative pressure of the water. In order to reduce this to the scale of 100 lb. horizontal measurement, the line, CE , is drawn, representing the water pressure to scale, that is, so that each horizontal measurement of the scale gives the pressure on the face at that point; and, allowing 50% for voids, halving this area gives the line, CD , between which and the vertical face any horizontal line measures the water pressure. Extending these pressure areas where they overlap gives the line, BD , which represents the total pressure against the face, measured horizontally.

Pg 376

Next, as to the question of buoyancy in Class A materials. If a submerged structure rests firmly on a bottom of more or less firm sand, its buoyancy, as indicated by the experiments, will only be a percentage of its buoyancy in pure water, corresponding to the voids in the sand. In practice, however, an attempt to show this condition will fail, owing to the fact that in such a structure the water will almost immediately work under the edge and bottom, and cause the structure to rise, and the test can only be made by measuring the difference in uplift in a heavier-than-water structure, as shown in Experiment No. 5. For, if a structure lighter than the displaced water be buried in sand sufficiently deep to insure it against the influx of large volumes of water below, it will not rise. That this is not due entirely to the friction of the solid material on the sides has been demonstrated by the observation of subaqueous structures, which always tend to subside rather than to lift during or following disturbance of the surrounding earth.

The following is quoted from the paper by Charles M. Jacobs, M. Am. Soc. C. E., on the North River Division of the Pennsylvania Railroad Tunnels:^[E]

"There was considerable subsidence in the tunnels during construction and lining, amounting to an average of 0.34 ft. between the bulkhead lines. This settlement has been constantly decreasing since construction, and appears to have been due almost entirely to the disturbances of the surrounding materials during construction. The silt weighs about 100 lb. per cu. ft. * * * and contains about 38% of water. It was found that whenever this material was disturbed outside the tunnels a displacement of the tunnels followed."

This in substance confirms observations made in the Battery tubes that subsidence of the structure

followed disturbance of the outside material, although theoretically the tubes were buoyant in the aqueous material.

The writer would urge, however, that, in all cases of submerged structures only partially buried in solid material, excess weighting be used to cover the contingencies of vibration, oscillation, etc., to which such structures may be subjected and which may ultimately allow leads of water to work their way underneath.

On the other hand, he urges that, in cases of floor areas of deeply submerged structures, such as tunnels or cellars, the pressure to be resisted should be assumed to be only slightly in excess of that corresponding to the pressure due to the water through the voids.

The question of pressure, etc., in Class B, or semi-aqueous materials will be considered next. Of these materials, as already shown, there are two types: (a) sand in which the so-called quicksand is largely in excess of any normal voids, and (b) plastic and viscous materials. The writer believes that these materials should be treated as mixtures of solid and watery particles, in the first of which the quicksand, or aqueous portion, being virtually in suspension, may be treated as water, and it must be concluded that the action here will be similar to that of sand and pure water, giving a larger value to the properties of water than actually exists. If, for instance, it should be found that such a mixture contained 40% of pure water, the writer would estimate its pressure on or against a structure as (a) that of a moist sand standing at a steep angle of repose, and (b) that of clear water, an allowance of 60% of the total volume being assumed, and the sum of these two results giving the total pressure. Until more definite data can be obtained by experiments on a larger scale, this assumed value of 60% of the total volume for the aqueous portion may be taken for all conditions of semi-aqueous materials, except, of course, where the solid and aqueous particles may be clearly defined, the pressures being computed as described in the preceding pages.

As to the question of pure quicksand (if such there be) and other aqueous materials of Class C, such as water, oil, mercury, etc., it has already been shown that they are to be considered as liquids of their normal specific gravity; that is, in calculating the air pressure necessary to displace them, one should consider their specific gravity only, as a factor, and not the total weight per volume including any impurities which they might contain undissolved.

In order to have a clearer conception of aqueous and semi-aqueous materials and their action, they must be viewed under conditions not ordinarily apparent. For instance, ideas of so-called quicksand are largely drawn from seeing structures sinking into it, or from observing it flowing through voids in the sheeting or casing. The action of sand and water under pressure is viewed during or after a slump, when the damage is being done, or has been done, whereas the correct view-point is under static conditions, before the slump takes place.

The following is quoted from the report of Mr. C.M. Jacobs, Chief Engineer of the East River Gas Tunnel, built in 1892-93:

"We found that the material which had heretofore been firm or stiff had, under erosion, obtained a soup-like consistency, and that a huge cavity some 3 ft. wide and 26 ft. deep had been washed up toward the river bed."

This would probably be a fair description of much of the material of this class met with in such work, if compressed air had not been used. The writer believes that in soft material surrounding submerged structures the water actually contained in the voids is not infrequently, after a prolonged period of rest, cut off absolutely from its sources of pressure and that contact with these sources of pressure will not again be resumed until a leak takes place through the structure; and, even when there is a small flow or trickling of water through such material, it confines itself to certain paths or channels, and is largely excluded from the general mass.

The broad principle of the bearing power of soil has been made the subject of too many experiments and too much controversy to be considered in a paper which is intended to be a description of experiments and observed data and notes therefrom. The writer is of the opinion, however, that entirely too little attention has been given to this bearing power of the soil; that while progress has been made in our knowledge of all classes of materials for structures, very little has been done which leads to any real knowledge of the material on which the foundation rests. For instance, it is inconceivable that 1 or 2 tons may sometimes be allowed on a square foot of soft clay, while the load on firm gravel is limited to from 4 to 6 tons. The writer's practical observations have convinced him that it is frequently much safer to put four times 6 tons on a square foot of gravel than it is to put one-fourth of 2 tons on a square foot of soft clay.

In connection with the bearing power of soil, the writer also believes that too little study has been given to the questions of the lateral pressure of earth, and he desires to quote here from some experiments described in a book^[F] published in England in 1876, to which his attention has recently been called. This book appears to have been intended for young people, but it is of interest to note the following quotations from a chapter entitled "Sand." This chapter begins by stating that:

"During the course of a lecture on the Suez Canal by Mr. John H. Pepper, which was delivered nightly by him at the Polytechnic Institute in London, he illustrated his lecture by some experiments designed to exhibit certain properties of sand, which had reference to the construction of the Suez Canal, and it is stated that though the properties in question were by no means to be classed among recent discoveries, the experiments were novel in form and served to interest the public audience."

Further quotation follows:

"When the Suez Canal was projected, many prophesied evil to the undertaking, from the sand in the desert being drifted by the wind into the canal, and others were apprehensive that where the canal was cut through the sand the bottom would be pushed up by the pressure on the banks * * *."

"The principle of lateral pressure may now be strikingly illustrated by taking an American

wooden pail and, having previously cut a large circular hole in the bottom, this is now covered with fine tissue paper, which should be carefully pasted on to prevent the particles of sand from flowing through the small openings between the paper and the wood * * * and being placed upright and rapidly filled with sand, it may be carried about by the handle without the slightest fear of the weight of the sand breaking through the thin medium. * * *

"Probably one of the most convincing experiments is that which may be performed with a cylindrical tube 18 in. long and 2 in. in diameter, open at both ends. A piece of tissue paper is carefully pasted on one end, so that when dry no cracks or interstices are left. The tube is filled with dry sand to a height of say 12 in. In the upper part is inserted a solid plug of wood 12 in. long and of the same or very nearly the same diameter as the inside of the tube, so that it will move freely up and down like the piston of an air pump. The tube, sand, and piston being arranged as described, may now be held by an assistant and the demonstrator, taking a sledge hammer, may proceed to strike steadily on the end of the piston and, although the paper will bulge out a little, the force of the blow will not break it.

Pg 380

"If the assistant holding the tube allows it to jerk or rebound after each blow of the hammer, the paper may break, because air and sand are driven down by the succeeding blow, and therefore it must be held steadily so that the piston bears fairly on the sand each time.

"A still more conclusive and striking experiment may be shown with a framework of metal constructed to represent a pail, the sides of which are closed up by pasting sheets of tissue paper inside and over the lower part. As before demonstrated, when a quantity of sand is poured into the pail the tissue paper casing at the bottom does not break, but if a sufficient quantity is used the sides formed of tissue paper bulge out and usually give way in consequence of the lateral pressure exerted by the particles of sand."

The writer has made the second experiment noted, with special apparatus, and finds that with tissue paper over the bottom of a 2-in. pipe, 15 in. long, about 12 in. of sand will stand the blow of a heavy sledge hammer, transmitted through a wooden piston, at least once and sometimes two or three times, while heavy blows given with a lighter hammer have no effect at all. That this is not due in any large measure to inertia can be shown by the fact that more than 200 lb. can safely be put on top of the wooden piston. It cannot be accounted for entirely by the friction, as the removal of the paper allows the sand to drop in a mass. The explanation is that the pressure is transmitted laterally to the sides, and as the friction is directly proportional to the pressure, the load or effect of the blow is carried by the proportional increase in the friction, and any diaphragm which will carry the direct bottom load will not have its stresses largely increased by any greater loading on top.

The writer believes that experiments will show that in a sand-jack the tendency will be for the sides to burst rather than the bottom, and that the outflow from an orifice at or near the bottom is not either greatly retarded or accelerated by ordinary pressure on top. The occurrence of abnormal voids, however, causes the sand to be displaced into them.

The important consideration of this paper is that all the experiments and observations noted point conclusively to the fact that pressure is transmitted laterally through ground, most probably along or nearly parallel to the angles of repose, or in cases of rock or stiff material, along a line which, until more conclusive experiments are made, may be taken as a mean between the horizontal and vertical, or approximately 45 degrees. There is no reason to believe that this is not the case throughout the entire mass of the earth, that each cubic foot, or yard, or mile is supported or in turn supports its neighboring equivalent along such lines. The theory is not a new one, and its field is too large to encompass within the limits of a single paper, but, for practical purposes, and within the limited areas to which we must necessarily be confined, the writer believes it can be established beyond controversy as true. Certain it is that no one has yet found, in ground free from water pressure or abnormal conditions, any evidence of greater pressure at the bottom of a deep shaft or tunnel than that near the surface. Pressures due to the widening of mines beyond the limits of safety must not be taken as a controversion of this statement, as all arches have limits of safety, more especially if the useless material below the theoretical intrados is only partly supported, or is allowed to be suspended from the natural arch.

Pg 381

The writer believes, also, that the question of confined foundations, in contradistinction to that of the spreading of foundations, may be worthy of full discussion, as it applies to safe and economical construction, and he offers, without special comment, the following observations:

He has found that, in soft ground, results are often obtained with small open caissons sunk to a depth of a few feet and cleaned out and filled with concrete, which offer much better resistance than spreading the foundation over four or five times the equivalent area.

He has found that small steel piles and coffer-dams, from 1-ft. cylinders to coffer-dams 4 or 5 ft. square, sunk to a depth of only 1 or 2 ft. below adjacent excavations in ordinary sand, have safely resisted loads four or five times as great as those usually allowed.

He believes that short cylinders, cleaned out and filled with concrete, or coffer-dams of short steel piling with the surface cleaned out to a reasonable depth and filled with concrete horizontally reinforced, will, in many instances, give as good results as, and, in most cases, very much better than, placing the foundation on an equivalent number of small long piles or a proportionately greater spread of foundation area, the idea being that the transmission of pressure to the sides of the coffer-dam will not only confine the side thrust, but will also transfer the loading in mass to a greater depth where the resistance to lateral pressure in the ground will be more stable; that is, the greater depth of foundation is gained without the increased excessive loading, or necessity for deep excavation.

Pg 382

As to the question of the bearing value and friction on piles, the writer believes that while the literature on engineering is full of experimental data relating to friction on caissons, there is little to show the real value of friction on piles. The assumption generally made of an assumed bearing value, and the deduction

therefrom of a value for the skin friction is fallacious. Distinction, also, is not made, but should be clearly drawn between skin friction, pure and simple, on smooth surfaces, and the friction due to pressure. Too often the bearing value on irregular surfaces as well as the bearing due to taper in piles, and lastly the resistance offered by binding, enter into the determination of so-called skin friction formulas. The essential condition of sinking a caisson is keeping it plumb; and binding, which is another way of writing increased bearing value, will oftentimes be fatal to success.

The writer believes that a series of observations on caissons sunk plumb under homogeneous conditions of ground and superficial smoothness will show a proportional increase of skin friction per square foot average for each increase in the size of caissons, as well as for increase of depth in the sinking up to certain points, where it may finally become constant, as will be shown later. The determination of the actual friction or coefficient of friction between the surfaces of the pile and the material it encounters, is not difficult to determine. In sand it is approximately 40% of the pressure for reasonably smooth iron or steel, and 45% of the pressure for ordinary wood surfaces. If, for instance, a long shaft be withdrawn vertically from moulding sand, the hole may remain indefinitely as long as water does not get into it or it does not dry out. This is due to the tendency of the sand to arch itself horizontally over small areas. The same operation cannot be performed on dry sand, as the arching properties, while protecting the pile from excessive pressure due to excessive length, will not prevent the loose sand immediately surrounding the pile from exerting a constant pressure against the pile, and it is of this pressure that 45% may be taken as the real value of skin friction on piles in dry sand.

Pg 383

In soft clays or peats which are displaced by driving, the tendency of this material to flow back into the original space causes pressure, of which the friction will be a measured percentage. In this case, however, the friction itself between the material and the clays or peat is usually very much less than 40%, and it is for this reason that piles of almost indefinite length may be driven in materials of this character without offering sufficient resistance to be depended on, as long as no good bearing ground is found at the point.

If this material is under water, and is so soft as to be considered semi-aqueous, the pressure per square foot will increase in diminishing proportion to the depth, and the pressure per area will soon approach and become a constant, due to the resistance offered by the lateral arching of the solid material; whereas, in large circular caissons, or caisson shafts, where the horizontal arching effect is virtually destroyed, or at least rendered non-effective until a great depth is reached, the pressure must necessarily vary under these conditions proportionately to the depth and size of the caisson in semi-aqueous material. On the other hand, in large caisson shafts, especially those which are square, the pressure at the top due to the solid material will also increase proportionately to the depth, as already explained in connection with the pressures of earth against sheeting and retaining walls.

The writer believes that the pressure on these surfaces may be determined with reasonable accuracy by the formulas already given in this paper, and with these pressures, multiplied by the coefficient of friction determined by the simplest experiment on the ground, results may be obtained which will closely approximate the actual friction on caissons at given depths. The friction on caissons, which is usually given at from 200 to 600 lb. per sq. ft., is frequently assumed to be the same on piles 12 in. or less in diameter, whereas the pressures on these surfaces, as shown, are in no way comparable.

The following notes and observations are given in connection with the skin friction and the bearing value of piles:

Pg 384

The writer has in his possession a copy of an official print which was recently furnished to bidders in connection with the foundation for a large public building in New York City. The experiments were made on good sand at a depth of approximately 43 ft. below water and 47 ft. below an adjacent excavation. In this instance a 16-in. pipe was sunk to the depth stated, cleaned out, and a 14-in. piston connected to a 10-in. pipe was inserted and the ground at the bottom of the 16-in. pipe subjected to a loading approximating 28 tons per sq. ft. After an initial settlement of nearly 3 in., there was no further settlement over an extended period, although the load of 28 tons per sq. ft. was continued.

In connection with some recent underpinning work, 14-in. hollow cylindrical piles 6 ft. long were sunk to a depth of 6 ft. with an ordinary hand-hammer, being excavated as driven. These piles were then filled with concrete and subjected to a loading in some cases approximating 60 tons. After a settlement ranging from 9 to 13 in., no further settlement took place, although the loading was maintained for a considerable period.

In connection with some other pile work, the writer has seen a 10-in. pipe, 3/8 in. thick, 4 ft. below the bottom of an open cylinder, at a depth of about 20 ft., sustain in gravel and sand a load approximating 50 tons when cleaned out to within 2 ft. of the bottom.

He has seen other cylindrical piles with a bearing ring of not more than 3/4 in. resting on gravel at a depth of from 20 to 30 ft., cleaned out practically to the bottom, sustain a measured load of 60 tons without settlement.

As to skin friction in sand, a case came under his observation wherein a 14-in. hollow cylindrical pile which had stood for 28 days at a depth of about 30 ft. in the sand, was cleaned out to its bottom and subjected to hydraulic pressure, measured by a gauge, and sunk 2 ft. into the sand without any pressure being registered on the gauge. It should be explained, however, that the gauge could be subjected to a pressure of 250 lb., equal to a total pressure of 7,000 lb. on the piston of the jack without registering, which corresponded, assuming it all as skin friction, to a maximum of not more than 78 lb. per sq. ft., but it should be noted that this included bearing value as well, and that the pressure was very far from 7,000 lb., in all probability, at the beginning of the test.

In the case of the California stove-pipe wells driven by the Board of Water Supply on Long Island, the writer is informed that one of these tubes, 12 in. in diameter, was sunk to a depth of 850 ft. In doing this work the pile was excavated below the footing with a sand pump and was then sunk by hydraulic pressure. Assuming the maximum capacity of the jacks at 100 tons, which is not probable, the skin friction could not have amounted to more than 75 lb. per sq. ft. It cannot be assumed in this case that the excavation of the material below the pile relieved the skin itself of some of its friction, as the operation

Pg 385

consumed more than 6 weeks, and, even if excess material was removed, it is certain that a large percentage of it would have had time to adjust itself before the operation was completed.



PLATE XXIX, FIG. 1.—A 14-GAUGE, 14-IN., HOLLOW (NON-TELESCOPIC), CALIFORNIA STOVE-PIPE PILE WHICH MET IMPENETRABLE MATERIAL.



PLATE XXIX, FIG. 2.—CHENOWETH PILE, PENETRATING HARD MATERIAL.

In connection with this, the writer may call attention to the fact that piles driven in silt along the North River, and in soft material at other places, are sometimes 90 ft. in length, and even then do not offer sufficient resistance to be depended on for loading. This is due to the fact that the end of the pile does not bear in good material.

The relation between bearing value and skin friction on a pile, where the end bearing is in good material, is well shown by a case where a wooden pile^[G] struck solid material, was distorted under the continual blows of the hammer, and was afterward exposed. It is also shown in the case of a 14-in. California stove-pipe pile, No. 14 gauge, the point of which met firm material. The result, as shown by [Fig. 1, Plate XXIX](#), speaks for itself. [Fig. 2, Plate XXIX](#), shows a Chenoweth pile which was an experimental one driven by its designer. This pile, after getting into hard material, was subjected to the blow of a 4,000-lb. hammer

falling the full length of the pile-driver, and the only result was to shatter the head of the pile, and not cause further penetration. Mr. Chenoweth has stated to the writer that he has found material so compact that it could not be penetrated with a solid pile—either with or without jetting—which is in line with the writer's experience.

The writer believes that the foregoing notes will show conclusively that the factor to be sought in pile work is bearing value rather than depth or skin friction, and, however valuable skin friction may be in the larger caissons, it cannot be depended on in the case of small piles, except in values ranging from 25 to 100 lb. per sq. ft.

In conclusion, he desires to thank the following gentlemen, who have contributed to the success of the experiments noted herein: Mr. James W. Nelson, of Richard Dudgeon, New York; Mr. George Noble, of John Simmons and Company, New York; and Mr. Pendleton, of Hindley and Pendleton, Brooklyn, N.Y.; all of whom have furnished apparatus for the experiments and have taken an interest in the results. And lastly, he desires especially to thank Mr. F.L. Cranford, of the Cranford Company, for men and material with which to make the experiments and without whose co-operation it would have been impracticable for the writer to have made them.

Pg 386

Throughout this paper the writer has endeavored, as far as possible, to deduce from his observations and from the observations of others, as far as he has been able to obtain them, practical data and formulas which may be of use in establishing the relationship between the pressure, resistance, and stability of earths; and, while he does not wish to dictate the character of the discussion, he does ask that those who have made observations of a similar character or who have available data, will, as far as possible, contribute the same to this discussion. It is only by such observations and experiments, and deductions therefrom, that engineers may obtain a better knowledge of the handling of such materials.

The writer believes that too much has been taken for granted in connection with earth pressures and resistance; and that, far too often, observations of the results of natural laws have been set down as phenomena. He believes that, both in experimenting and observing, the engineer will frequently find what is being looked for or expected and will fail to see the obvious alternative. He may add that his own experiments and observations may be criticized for the same reason, and he asks, therefore, that all possible light be thrown on this subject. A comparative study of much of our expert testimony or of the plans of almost any of the structures designed in connection with their bearing upon earth, or resistance to earth pressure, will show that under the present methods of interpretation of the underlying principles governing the calculations and designs relating to such structures, the results vary far too widely. Too much is left to the judgment of the engineer, and too frequently no fixed standards can be found for some of the most essential conditions.

Until the engineer can say with certainty that his calculations are reasonably based on facts, he is forced to admit that his design must be lacking, either in the elements of safety, on the one hand, or of economy, on the other, and, until he can give to his client a full measure of both these factors in fair proportion, he cannot justly claim that his profession has reached its full development.

Table 1 gives approximate calculations of pressures on two types of tunnels and on two heights of sheeted faces or walls, due to four varying classes of materials.

Pg 387

TABLE 1.—PRESSURES ON TYPICAL STRUCTURES UNDER VARYING ASSUMED CONDITIONS.

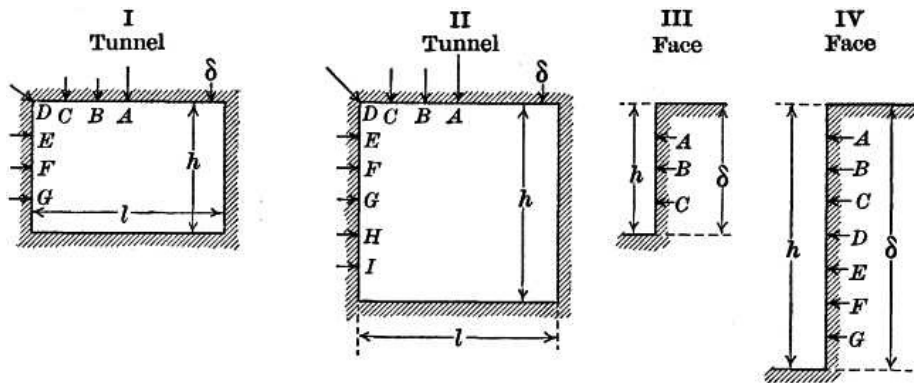

KEY TO TABLE OF PRESSURES, ETC.

h = exterior height, l = exterior width, δ = depth of cover, that is, D_E = earth, and D_W = water depth,

ϕ = angle of repose, and, for tunnels $D_W > D_E$ a depth

$$= \frac{l}{2} \left(45^\circ + \frac{\phi}{2} \right)$$

W_E = weight of 1 cu. ft. of earth = 90 lb.; W_W = weight of 1 cu. ft. of water = 62½ lb.

Conditions: 1 = normal sand, 2 = dry sand, 3 = supersaturated firm sand with 40% of voids, 4 = supersaturated semi-aqueous material, 60% aqueous, that is, 60% water and aqueous material.

Combined assumed conditions.	h	l	ϕ	D_E	Combined assumed conditions.	h	l	ϕ	D_E	D_W
I ₁	20	30	45°	40	I ₃	20	30	50°	40	60
I ₂	20	30	30°	40	I ₄	20	30	40°	40	60

II ₁	15	15	45°	40	II ₃	15	15	50°	40	60
II ₂	15	15	30°	40	II ₄	15	15	40°	40	60
III ₁	15		45°	15	III ₃	15		50°	15	15
III ₂	15		30°	15	III ₄	15		40°	15	15
IV ₁	30		45°	30	IV ₃	30		50°	30	30
IV ₂	30		30°	30	IV ₄	30		40°	30	30

APPROXIMATE PRESSURES ON TUNNELS, PER SQUARE FOOT.

Pressure per square foot, at	I ₁	I ₃	I ₃	I ₃	I ₂	I ₄	I ₄	I ₄	II ₁	II ₃	II ₃	II ₃	II ₂	II ₄	II ₄	II ₄
	Earth.	Earth.	Water.	Comb-ined.	Earth.	Earth.	Water.	Comb-ined.	Earth.	Earth.	Water.	Comb-ined.	Earth.	Earth.	Water.	Comb-ined.
A	3,240	3,690	1,500	5,190	2,325	2,880	2,250	5,130	1,485	1,755	1,500	3,255	1,035	1,305	2,250	3,555
B	2,745	3,105	1,500	4,605	1,845	2,385	2,250	4,635	1,305	1,485	1,500	2,985	945	1,170	2,250	3,420
C	2,160	2,475	1,500	3,975	1,350	1,800	2,250	4,050	1,125	1,215	1,500	2,715	810	990	2,250	3,240
D	450	540	1,500	2,040	450	450	2,250	2,700	405	405	1,500	1,905	540	450	2,250	2,700
E	360	360	1,625	1,985	450	450	2,438	2,888	405	405	1,625	2,030	540	450	2,438	2,888
F	270	270	1,750	2,025	450	360	2,626	2,986	360	360	1,750	2,110	540	450	2,626	3,076
G	225	225	1,875	2,100	360	270	2,814	3,084	315	315	1,875	2,190	360	360	2,814	3,174
H									180	225	2,000	2,225	180	180	3,000	3,180
I									90	110	2,175	2,285	135	135	3,188	3,323

APPROXIMATE PRESSURES ON SHEETED TRENCH FACES OR WALLS

Pressure per square foot at	III ₁	III ₃	III ₃	III ₃	III ₂	III ₄	III ₄	III ₄	IV ₁	IV ₃	IV ₃	IV ₃	IV ₂	IV ₄	IV ₄	IV ₄
	Earth.	Earth.	Water.	Total earth and water.	Earth.	Earth.	Water.	Total earth and water.	Earth.	Earth.	Water.	Total earth and water.	Earth.	Earth.	Water.	Total earth and water.
A	575	510	100	610	1,350	810	140	950	1,370	1,210	100	1,310	3,175	1,910	150	2,060
B	400	350	190	540	900	540	260	800	1,170	1,030	200	1,230	2,700	1,610	290	1,900
C	200	175	280	455	450	270	380	650	970	855	290	1,145	2,250	1,355	430	1,785
D									775	680	370	1,050	1,800	1,100	570	1,670
E									590	515	460	975	1,350	820	710	1,530
F									400	350	560	910	900	540	860	1,400
G									190	170	650	820	450	275	1,000	1,275

FOOTNOTES:

- [A] Presented at the meeting of May 18th, 1910.
- [B] *Transactions, Am. Soc. C. E.*, Vol. LX, p. 1.
- [C] *Engineering News*, July 1st, 1909.
- [D] From "Gravel for Good Roads."
- [E] *Transactions, Am. Soc. C. E.*, Vol. LXVIII, pp. 58-60.
- [F] "Discoveries and Inventions of the Nineteenth Century," by Robert Routledge, Assistant Examiner in Chemistry and in Natural Philosophy to the University of London.
- [G] *Engineering News*, January 15th, 1909.

DISCUSSION

T. KENNARD THOMSON, M. AM. SOC. C. E.—Although the author deserves great credit for the careful and thorough manner in which he has handled this subject, his paper should be labeled "Dangerous for Beginners," especially as he is an engineer of great practical experience; if he were not, comparatively little attention would be paid to his statements. The paper is dangerous because many will read only portions of it, or will not read it thoroughly. For instance, at the beginning, the author cites several experiments in which considerable force is required to start the lifting of a weight or plunger in sand and water and much less after the start. This reminds the speaker of the time when, as a schoolboy, he tried to pick up stones from the bottom of the river and was told that the "suction" was caused by atmospheric pressure.

The inference is that tunnels, etc., in sand, etc., are not in any danger of rising, even though they are lighter than water. Toward the end of the paper, however, the author states that tunnels should be weighted, but he rather spoils this by stating that they should be weighted only enough to overcome the actual water pressure, that is, between the voids of the sand. It seems to the speaker that the only really

safe way is to make the tunnel at least as heavy as the water displaced in order to prevent it from coming up, and to take other measures to prevent it from going down. The City of Toronto, Canada, formerly pumped its water supply through a 6-ft. iron pipe, buried in the sand under Toronto Bay and then under Toronto Island, with an intake in the deep water of the lake. During a storm a mass of seaweed, etc., was washed against the intake, completely blocking it, and although the man at the pumping station knew that something was wrong, he continued to pump until the water was drawn out of the pipe, with the result that about half a mile of the conduit started to rise and then broke at several places, thus allowing it to fill with water. Eventually, the city went down to bed-rock under the Bay for its water tunnel.

Another reason for calling this paper dangerous for beginners is that it is improbable that experienced engineers or contractors will omit the bracing at the bottom, although, since the paper was printed, a glaring instance has occurred where comparatively little bracing was put in the bottom of a 40-ft. cut, the result being a bad cave-in from the bottom, although all the top braces remained in place. Most engineers will agree that nearly every crib which has failed slipped out from the bottom, and did not turn over.

Pg 390

The objection to the angle of repose is that it is not possible to ascertain it for any material deposited by Nature. It could probably be ascertained for a sand bank deposited by Man, but not for an excavation to be made in the ground, for it is known that nearly all earth, etc., has been deposited under great pressure, and is likely to be cemented together by clay, loam, roots, trees, boulders, etc., and differs in character every few feet.

A deep vertical cut can often be made, even in New York quicksand, from which the water has been drawn, and, if not subjected to jars, water, etc., this material will stand for considerable time and then come down like an avalanche, killing any one in its way. In such cases very little bracing would prevent the slide from starting, provided rain, etc., did not loosen the material.

The author, of course, treats dry and wet materials differently, but there are very few places where dry material is not likely to become wet before the excavation is completed.

In caisson work, if the caisson can be kept absolutely plumb, it can be sunk without having to overcome much friction, while, on the other hand, if it is not kept plumb, the material is more or less disturbed and begins to bind, causing considerable friction. The author claims that the pressure does not increase with the depth, but all caisson men will probably remember that the friction to be overcome per square foot of surface increases with the depth.

In calculating retaining walls, many engineers add the weight of the soil to the water, and calculate for from 90 to 100 lb. per cu. ft. The speaker is satisfied that in the so-called New York quicksand it is sufficient to use the weight of the water only. If the sand increased the side pressure above the water pressure, engineers would expect to use more compressed air to hold it back, while, as a matter of fact, the air pressure used seldom varies much from that called for by the hydrostatic head.

Although allowance for water pressure is sufficient for designing retaining walls in New York quicksand, it is far from sufficient in certain silty materials. For instance, in Maryland, a coffer-dam, excavated to a depth of 30 ft. in silt and water, had the bottom shoved in 2 ft., in spite of the fact that the waling pieces were 5 ft. apart vertically at the top and 3 ft. at the bottom, and were braced with 12 by 12-in. timbers, every 7 ft. horizontally. The walings split, and the cross-braces cut into the waling pieces from 1 to 2 in.; in other words, the pressure seemed to be almost irresistible. This is quite a contrast to certain excavations in Brooklyn, which, without any bracing whatever, were safely carried down 15 ft.

Pg 391

Any engineer who tries to guess at the angle of repose, and, from the resulting calculations, economizes on his bottom struts, will find that sooner or later an accident on one job will cause enough loss of life and money to pay for conservative timbers for the rest of his life. So much for side pressures. As to the pressure in the roof of a tunnel, probably every engineer will agree that almost any material except unfrozen water will tend to arch more or less, but how much it is impossible to say. It is doubtful whether any experienced engineer would ever try to carry all the weight over the roof, except in the case of back-fill, and even then he would have to make his own assumption (which sounds more polite than "guess").

The author has stated, however, that when the tunnel roof and sides are in place, no further trouble need be feared. On the contrary, in 1885, the Canadian Pacific Railroad built a tunnel through clayey material and lined it with ordinary 12 by 12-in. timber framing, about 2 or 3 ft. apart. After the tunnel was completed, it collapsed. It was re-excavated and lined with 12 by 12-in. timbers side by side, and it collapsed again; then the tunnel was abandoned, and, for some 20 years, the track, carried around on a 23° curve, was used until a new tunnel was built farther in. This trouble could have been caused either by the sliding or swelling of the material, and the speaker is inclined to believe that it was caused by swelling, for it is known, of course, that most material has been deposited by Nature under great pressure, and, by excavating in certain materials, the air and moisture would cause those materials to swell and become an irresistible force.

To carry the load, Mr. Meem prefers to rely on the points of the piles rather than the side friction. In such cases the pile would act as a post, and would probably fail when ordinarily loaded, unless firmly supported at the sides. The speaker has seen piles driven from 80 to 90 ft. in 10 min., which offered almost no resistance, and yet, a few days later, they would sustain 40 tons each. No one would dream of putting 40 tons on a 90-ft. pile resting on rock, if it were not adequately supported.

It is the speaker's opinion that bracing should not be omitted for either piles or coffer-dams.

CHARLES E. GREGORY, ASSOC. M. AM. SOC. C. E.—In describing his last experiment with the hydraulic chambers and plunger, Mr. Meem states that, after letting the pressure stand at 25 lb., etc., the piston came up. This suggests that the piston might have been raised at a much lower pressure, if it had been allowed to stand long enough.

The depth and coarseness of the sand were not varied to ascertain whether any relation exists between them and the pressure required to lift the piston. If the pressure varied with the depth of sand, it would indicate that the reduction was due to the resistance of the water when finely divided by the sand; if it

varied with the coarseness of the sand, as it undoubtedly would, especially if the sand grains were increased to spheres 1 in. in diameter, it would show that it was independent of the voids in the sand, but dependent on dividing the water into thin films.

The speaker believes that the greater part of the reduction of pressure on the bottom of the piston might be better explained by the viscosity of the water, than to assume that a considerable part of the plunger is not in contact with it. The water, being divided by fine sand into very thin films, has a tensile strength which is capable of resisting the pressure for at least a limited time.

If the water is capable of exerting its full hydrostatic pressure through the sand, the total pressure would be the full hydrostatic pressure on the bottom of the piston where in contact, and, where separated from it by a grain of sand, the pressure would be decreased only by the weight of the grain. If a large proportion of the top area of a grain is in contact, as assumed by the author, this reduction of pressure would be very small. A correct interpretation can be obtained only after more complete experiments have been made.

For horizontal pressures exerted by saturated sands on vertical walls, it has not been demonstrated that anything should be deducted from full water pressure. No matter how much of the area is in direct contact with the sand rather than the water, the full water pressure would be transmitted through each sand grain from its other side and, if necessary, from and through many other grains which may be in turn in contact with it. The pressure on such a wall will be water pressure over its entire surface, and, in addition, the thrust of the sand after correcting for its loss of weight in the water.

The fact that small cavities may be excavated from the sides of trenches or tunnels back of the sheeting proves only that there is a local temporary arching of the material, or that the cohesion of the particles is sufficient to withstand the stress temporarily, or that there is a combination of cohesion and arching. The possibility of making such excavations does not prove that pressure does not exist at such points. That sand or earth will arch under certain conditions has long been an accepted fact. The sand arches experimented with developed their strength only after considerable yielding and, therefore, give no index of the distribution or intensity of stress before such yielding. Furthermore, sand and earth in Nature are not constrained by forms and reinforcing rods.

Mr. Meem's paper is very valuable in that it presents some unusual phenomena, but many of the conclusions drawn therefrom cannot be accepted without further demonstration.

FRANCIS W. PERRY, ASSOC. M. AM. SOC. C. E.—Pressure-gauge observations on a number of pneumatic caissons recently sunk, through various grades of sand, to rock at depths of from 85 to 105 ft. below ground-water, invariably showed working-chamber air-pressures equal, as closely as could be observed, to the hydrostatic pressures computed, for corresponding depths of cutting-edge, as given in Table 2.

These observations and computations were made by the speaker in connection with the caisson foundations for the Municipal Building, New York City.

TABLE 2.—EQUIVALENT FEET OF DEPTH BELOW WATER PER POUND PRESSURE.

Pressure, in pounds.	Equivalent feet of depth.	Equivalent elevation for water at—6.85.	Observed pressure.
	M.H.W.	Ground-water.	
1	2.31	9.06	Practically the same as computed for ground-water.
2	4.63	11.48	
3	6.94	13.79	
4	9.25	16.10	
5	11.57	18.42	
6	13.88	20.73	
7	16.19	23.04	
8	18.50	25.35	
9	20.82	27.67	
10	23.13	29.98	
11	25.44	32.29	
12	27.76	34.61	
13	30.07	36.92	
14	32.38	39.23	
15	34.70	41.55	
16	37.01	43.86	
17	39.32	46.17	
18	41.63	48.48	
19	43.95	50.80	
20	46.26	53.11	
21	48.57	55.42	
22	50.89	57.74	
23	53.20	60.05	
24	55.51	62.36	
25	57.82	64.67	
26	60.14	66.99	
27	62.45	69.30	
28	64.76	71.61	
29	67.08	73.93	

30	69.39	76.24
31	71.70	78.55
32	74.01	80.86
33	76.33	83.18
34	78.64	85.49
35	80.95	87.80
36	83.27	90.12
37	85.58	92.43
38	87.89	94.74
39	90.20	97.05
40	92.52	99.37
41	94.83	101.68
42	97.14	103.99
43	99.46	106.31
44	101.77	108.62
45	104.08	110.93
46	106.39	113.24

NOTE.—Equivalent depth in feet = $\frac{34}{14.7} \times$ pressure.

E.P. GOODRICH, M. AM. SOC. C. E. (by letter).—This paper is to be characterized by superlatives. Parts of it are believed to be exceptionally good, while other parts are considered equally dangerous. The author's experimental work is extremely interesting, and the writer believes the results obtained to be of great value; but the analytical work, both mathematical and logical, is emphatically questioned.

The writer believes that, in the design of permanent structures, consideration of arch action should not be included, at least, not until much more information has been obtained. He also believes that the design of temporary structures with this inclusion is actually dangerous in some instances, and takes the liberty of citing the following statement by the author, with regard to his first experiment:

"About an hour after the superimposed load had been removed, the writer jostled the box with his foot sufficiently to dislodge some of the exposed sand, when the arch at once collapsed and the bottom fell to the ground."

The writer emphatically questions the author's ideas as to "the thickness of key" which "should be allowed" over tunnels, believing that conditions within an earth mass, except in very rare instances, are such that true arch action will seldom take place to any definite extent, through any considerable depths. Furthermore, the author's reason for bisecting the angle between the vertical and the angle of repose of the material, when he undertakes to determine the thickness of key, is not obvious. This assumption is shown to be absurd when carried to either limit, for when the angle of repose equals zero, as is the case with water, this method would give a definite thickness of key, while there can be absolutely no arch action possible in such a case; and, when the angle of repose is 90°, as may be assumed in the case of rock, this method would give an infinite thickness of key, which is again seen to be absurd. It would seem as if altogether too many unknowable conditions had been assumed. In any case, no arch action can be brought into play until a certain amount of settlement has taken place so as to bring the particles into closer contact, and in such a way that the internal stresses are practically those only of compression, and the shearing stresses are within the limits possible for the material in question.

The author has repeatedly made assumptions which are not borne out by the application of his mathematical formulas to actual extreme conditions. This method of application to limiting conditions is concededly sometimes faulty; but the writer believes that no earth pressure theory, or one concerning arch action, can be considered as satisfactory which does not apply equally well to hydraulic pressure problems when the proper assumptions are made as to the factors for friction, cohesion, etc. For example, when the angle of repose is considered as zero, in the author's first formula for W_1 , the value becomes $\frac{1}{2} W_1$, whereas it should depend solely on the depth, which does not enter the formula, and not at all on the width of opening, l , which is thus included.

The author has given no experiments to prove his statement that "the arch thrust is greater in dryer sand," and the accuracy of the statement is questioned. Again, no reason is apparent for assuming the direction of the "rakers" in Fig. 3 as that of the angle of repose. The writer cannot see why that particular angle is repeatedly used, when almost any other would give results of a similar kind. The author has made no experiments which show any connection between the angle of repose, as he interprets it, and the lines of arch action which he assumes to exist.

With regard to the illustration of the condition which is thought to exist when the "material is composed of large bowling balls," supposedly all of the same size, the writer believes the conclusion to be erroneous, and that this can be readily seen by inspection of a diagram in which such balls are represented as forming a pile similar to the well-known "pile of shells" of the algebras, in the diagram of which a pile of three shells, resting on the base, has been omitted. It is then seen that unless the pressures at an angle of 60° with the horizontal are sufficient to produce frictional resistance of a very large amount, the balls will roll and instantly break the arch action suggested by the author. Consequently, an almost infinitesimal settlement of the "centering" may cause the complete destruction of an arch of earth.

The author's logic is believed to be entirely faulty in many cases because he repeatedly makes assumptions which are not in accordance with demonstrated fact, and finally sums up the results by the statement: "It is conceded" (line 2, p. 357, for example), when the writer, for one, has not even conceded the accuracy of the assumptions. For instance, the author's well-known theory that pressures against retaining walls are a maximum at the top and decrease to zero at the bottom, is in absolute contradiction to the results of experiments conducted on a large scale by the writer on the new reinforced concrete

retaining wall near the St. George Ferry, on Staten Island, New York City, which will soon be published, and in which the usual law of increase of lateral pressure with depth is believed to be demonstrated beyond question. It must be conceded that a considerable arch action (so-called) actually exists in many cases; but it should be equally conceded by the advocates of the existence of such action that changes in humidity, due to moving water, vibration, and appreciable viscosity, etc., will invariably destroy this action in time. In consequence, the author's reasoning in regard to the pressures against the faces of retaining walls is believed to be open to grave question as to accuracy of assumption, method, and conclusion.

The author is correct in so far as he assumes that "the character of the stresses due to the thrust of the material will" not "change if bracing should be substituted for the material in the area" designated by him, etc., provided he makes the further assumption that absolutely no motion, however infinitesimal, has taken place meantime; but, unless such motion has actually taken place, no arch action can have developed. An arch thrust can result only with true arch action, that is, with stable abutments, and the mass stressed wholly in compression, with corresponding shortening of the arch line. The arch thrust must be proportional to the elastic deformation (shortening) of the arch line. If any such arch as is shown in Fig. 5 is assumed to carry the whole of the weight of material above it, that assumed arch must relieve all the assumed arches below. Therefore each of the assumed arches can carry nothing more than its own mass. Otherwise the resulting thrust would increase with the depth, which is opposed to the author's theory.

Pg 396

Turning again to the condition that each arch can carry only its own weight: if these arches are assumed of thicknesses proportional to the distance upward from the bottom of the wall, they will be similar figures, and it is easily demonstrated that the thrust will then be uniform in amount throughout the whole height of the wall, except, perhaps, at the very top. This condition is contrary to the author's ideas and also to the facts as demonstrated by the writer's experiment on the 40-ft. retaining wall at St. George. Consequently, the author's statement: "nor can anyone *** doubt that the top timbers are stressed more heavily than those at the bottom," is emphatically doubted and earnestly denied by the writer. Furthermore, "the assumption" made by the author as to "the tendency of the material to slide" so as to cause it "to wedge *** between the face of the sheeting *** and some plane between the sheeting and the plane of repose," is considered as absolutely unwarranted, and consequently the whole conclusion is believed to be unjustified. Nor is the author's assumption (line 5, p. 361), that "the thrust * * * is measured by its weight divided by the tangent of the *** angle of repose" at all obvious.

The author presents some very interesting photographs showing the natural surface slopes of various materials; but it is interesting to note that he describes these slopes as having been produced by the "continual slipping down of particles." The vast difference between angles of repose produced in this manner by the rolling friction of particles and the internal angles of friction, which must be used in all earth-pressure investigations, has been repeatedly called to the attention of engineers by the writer.^[H]

The writer's experiments are entirely in accord with those of the author in which the latter claims to demonstrate that "earth and water pressures act independently of each other," and the writer is much delighted that his own experiments have been thus confirmed.

In Experiment No. 3, the query is naturally suggested: "What would have been the result if the nuts and washers had first been tightened and water then added?" Although the writer has not tried the experiment, he is rather inclined to the idea that the arch would have collapsed. With regard to Experiment No. 5, there is to be noted an interesting possibility of its application to the theoretical discussion of masonry dams, in which films of water are assumed to exist beneath the structure or in crevices or cracks of capillary dimensions. The writer has always considered the assumptions made by many designing engineers as unnecessarily conservative. In regard to the author's conclusions from Experiment No. 6, it should be noted that no friction can exist between particles of sand and surrounding water unless there is a tendency of the latter to move; and that water in motion does not exert pressures equal to those produced when in a static condition, the reduction being proportional to the velocity of flow.

Pg 397

The author's conclusion (p. 371), that "pressure will cause the quicksand to set up hydraulic action," does not seem to have been demonstrated by his experiments, but to be only his theory. In this instance, the results of the writer's experiments are contrary to the author's theory and conclusion.

The writer will heartily add his protest to that of the author "against considering semi-aqueous masses, such as soupy sands, soft concrete, etc., as exerting hydrostatic pressure due to their weight in bulk, instead of to the specific gravity of the basic liquid." Again, similarly hearty concurrence is given to the author's statement:

"If the solid material in any liquid is agitated, so that it is virtually in suspension, it cannot add to the pressure, and if allowed to subside it acts as a solid, independently of the water contained with it, although the water may change somewhat the properties of the material, by increasing or changing its cohesion, angle of repose, etc."

On the other hand, it is believed that the author's statement, as to "the tendency of marbles to arch," a few lines above the one last quoted, should be qualified by the addition of the words, "only when a certain amount of deflection has taken place so as to bring the arch into action." Again, on the following page, a somewhat similar qualification should be added to the sentence referring to the soft clay arch, that it would "stand if the rods supporting the intrados of the arch were keyed back to washers covering a sufficiently large area," by inserting the words, "unless creeping pressures (such as those encountered by the writer in his experiments) were exceeded."

The writer considers as very doubtful the formula for D_x , which is the same as that for W_1 , already discussed. The author's statement that "additional back-fill will [under certain circumstances] lighten the load on the structure," is considered subject to modification by some such clause as the following, "the word 'lighten' here being understood to mean the reduction to some extent of what would be the total pressure due to the combined original and added back-fill, provided no arch action occurred."

The writer is in entire agreement with the author as to the probability that water is often "cut off

absolutely from its source of pressure," with the attendant results described by the author (p. 378); and again, that too little attention has been given to the bearing power of soil, with the author's accompanying criticism.

Pg 398

The writer cannot see, however, where the author's experiments demonstrate his statement "that pressure is transmitted laterally through ground, most probably along or nearly parallel to the angles of repose," or any of the conclusions drawn by him in the paragraph (p. 381), which contains this questionable statement. Again the writer is at a loss as to how to interpret the statement that the author has found that "better resistance" has been offered by "small open caissons sunk to a depth of a few feet and cleaned out and filled with concrete" than by "spreading the foundation over four or five times the equivalent area." The writer agrees with the author in the majority of his statements as to the "bearing value and friction on piles," but believes that he is indulging in pure theory in some of his succeeding remarks, wherein he ascribes to arch action the results which he believes would be observed if "a long shaft be withdrawn vertically from moulding sand." These phenomena would be due rather to capillary action and the resulting cohesion.

Naturally, the writer doubts the author's conclusions as to the pressure at the top of large square caisson shafts when he states that "the pressure at the top * * * will * * * increase proportionately to the depth." Again, the author is apparently not conversant with experiments made by the Dock Department of New York City, concerning piles driven in the Hudson River silt, which showed that a single heavily loaded pile carried downward with it other unloaded piles, driven considerable distances away, showing that it was not the pile which lacked in resistance, as much as the surrounding earth.

In conclusion, the writer heartily concurs with the statement that "too much has been taken for granted in connection with earth pressures and resistance," and he is sorry to be forced to add that he believes the author to be open to the criticism which he himself suggests, that "both in experimenting and observing, the engineer [and in this case the author] will frequently find what is being looked for or expected and will fail to see the obvious alternative."

FRANCIS L. PRUYN, M. AM. SOC. C. E. (by letter).—Mr. Meem should be congratulated, both in regard to the highly interesting theories which he advances on the subject of sand pressures—the pressures of subaqueous material—and on his interesting experiments in connection therewith.

The experiment in which the plunger on the hydraulic ram is immersed in sand and covered with water does not seem to be conclusive. By this experiment the author attempts to demonstrate that the pressure of the water transmitted through the sand is only about 40% as great as when the sand is not there. The travel of ground-water through the earth is at times very slow, and occasionally only at the rate of from 2 to 3 ft. per hour. In the writer's opinion, Mr. Meem's experiment did not cover sufficient time during which the pressure was maintained at any given point. It is quite probable that it may take 15 or 20 min. for the full pressure to be transmitted through the sand to the bottom of the plunger, and it is hoped, therefore, that he will make further experiments lasting long enough to demonstrate this point.

Pg 399

In regard to the question of skin friction on caissons and piles, it may be of interest to mention an experiment which the writer made during the sinking of the large caissons for the Williamsburg Bridge. These caissons were about 70 ft. long and 50 ft. wide. The river bottom was about 50 ft. below mean high water, and the caissons penetrated sand of good quality to a depth of from 90 to 100 ft. below that level. On two occasions calculations were made to determine the skin friction while the caissons were being settled. With the cutting edge from 20 to 30 ft. below the river bottom, the calculations showed that the skin friction was between 500 and 600 lb. per sq. ft. The writer agrees with Mr. Meem that, in the sinking of caissons, the arch action of sand is, in a great measure, destroyed by the compressed air which escapes under the cutting edge and percolates up through the material close to the sides of the caissons.

With reference to the skin friction on piles, the writer agrees with Mr. Meem that in certain classes of material this is almost a negligible quantity. The writer has jacked down 9-in. pipes in various parts of New York City, and by placing a recording gauge on the hydraulic jack, the skin friction on the pile could be obtained very accurately. In several instances the gauge readings did not vary materially from the surface down to a penetration of 50 ft. In these instances the material inside the pipe was cleaned out to within 1 ft. of the bottom of the pile, so that the gauge reading indicated only the friction on the outside of the pipe plus the bearing value developed by its lower edge. For a 9-in. pipe, the skin friction on the pile plus the bearing area of the bottom of the pipe seems to be about 20 tons, irrespective of the depth. After the pipe had reached sufficient depth, it was concreted, and, after the concrete had set, the jack was again placed on it and gauge readings were taken. It was found that in ordinary sands the concreted steel pile would go down from 3 to 6 in., after which it would bring up to the full capacity of a 60-ton jack, showing, by gauge reading, a reaction of from 70 to 80 tons.

It is the writer's opinion that, in reasonably compact sands situated at a depth below the surface which will not allow of much lateral movement, a reaction of 100 tons per sq. ft. of area can be obtained without any difficulty whatever.

FRANK H. CARTER, ASSOC. M. AM. SOC. C. E. (by letter).—Mr. Meem has contributed much that is of value, particularly on water pressures in sand; just what result would be obtained if coarse crushed stone or similar material were substituted for sand in Experiment No. 6, is not obvious.

Pg 400

It has been the practice lately, among some engineers in Boston, as well as in New York City, to assume that water pressures on the underside of inverts is exerted on one-half the area only. The writer, however, has made it a practice first to lay a few inches of cracked stone on the bottom of wet excavations in order to keep water from concrete which is to be placed in the invert. In addition to the cracked stone under the inverts, shallow trenches dug laterally across the excavation to insure more perfect drainage, have been observed. Both these factors no doubt assist the free course of water in exerting pressure on the finished invert after the underdrains have been closed up on completion of the work. The writer, therefore, awaits with interest the repetition of Experiment No. 6, with water on the

bottom of a piston buried in coarse gravel or cracked stone.

As for the arching effect of sand, the writer believes that Mr. Meem has demonstrated an important principle, on a small scale. It must be regretted, however, that the box was not made larger, for, to the writer, it appears unsafe to draw such sweeping conclusions from small experiments. As small models of sailboats fail to develop completely laws for the design and control of large racing yachts, so experiments in small sand boxes may fail to demonstrate the laws governing actual pressures on full-sized structures.

For some time the writer has been using a process of reasoning similar to that of the author for assumptions of earth pressure on the roofs of tunnel arches, except that the vertical forces assumed to hold up the weight of the earth have been ascribed to cohesion and friction, along what might be termed the sides of the "trench excavation."

The writer fails to find proof in this paper of the author's statement that earth pressures on the sides of a structure buried in earth are greater at the top than at the bottom of a trench. That some banks are "top-heavy," is, no doubt, a fact, the writer having often heard similar expressions used by experienced trench foremen, but, in every case called to his attention, local circumstances have caused the top-heaviness, either undermining at the bottom of the trench, too much banked earth on top, or the earth excavated from the trench being too near the edge of the cut.

For some years the writer has been making extended observations on deep trenches, and, thus far, has failed to find evidence, except in aqueous material, of earth pressures which might be expected from the known natural slope of the material after exposure to the elements; and this latter feature may explain why sheeted trenches stand so much better than expected. If air had free access to the material, cohesion would be destroyed, and theoretical pressures would be more easily developed. With closely-sheeted trenches, weathering is practically excluded, and the bracing, which seemingly is far too light, holds up the trench with scarcely a mark of pressure. As an instance, in 1893, the writer was successfully digging sewer trenches from 10 to 14 ft. deep, through gravel, in the central part of Connecticut, without bracing; because of demands of the work in another part of the city, a length of several hundred feet of trench was left open for three days, resulting in the caving-in of the sides. The elements had destroyed the cohesion, and the sides of the trenches no longer stood vertically.

Pg 401

Recently, in the vicinity of Boston, trenches, 32 ft. wide, and from 25 to 35 ft. deep, with heavy buildings on one side, have been braced with 8 by 10-in. stringers, and bracers at 10-ft. centers longitudinally, and from 3 to 5 ft. apart vertically; this timbering apparently was too slight for pressures which, theoretically, might be expected from the natural slope of the material. Just what pressures develop on the sides of the structures in these deep trenches after pulling the top sheeting (the bottom sheeting being left in place) is, of course, a matter of conjecture. There can be no doubt that there is an arching of the material, as suggested by the author. How much this may be assisted by the practical non-disturbance of the virgin material is, of course, indeterminate. That substructures and retaining walls designed according to the Rankine or similar theories have an additional factor of safety from too generous an assumption in regard to earth pressure is practically admitted everywhere. It is almost an engineering axiom that retaining walls generally fail because of insufficient foundation only.

For the foregoing reasons, and particularly from observations on the effect of earth pressures on wooden timbers used as bracing, the writer believes that, ordinarily, the theoretical earth pressures computed by Rankine and Coulomb are not realized by one-half, and sometimes not even by one-third or one-quarter in trenches well under-drained, rapidly excavated, and thoroughly braced.

J.C. MEEM, M. AM. SOC. C. E. (by letter).—The writer has been much interested in this discussion, and believes that it will be of general value to the profession. It is unfortunate, however, that several of the points raised have been due to a careless reading of, or failure to understand, the paper.

Taking up the discussion in detail, the writer will first answer the criticisms of Mr. Goodrich. He says:

"The writer believes that, in the design of permanent structures, consideration of arch action should not be included, at least, not until more information has been obtained. He also believes that the design of temporary structures with this inclusion is actually dangerous in some instances."

If the arching action of earth exists, why should it not be recognized and considered? The design of timbering for a structure to rest, for instance, at a depth of from 200 to 300 ft. in normal dry earth, without considering this action, would be virtually prohibitive.

Mr. Goodrich proceeds to show one of the dangers of considering such action by quoting the writer, as follows:

"About an hour after the superimposed load had been removed, the writer jostled the box with his foot sufficiently to dislodge some of the exposed sand, when the arch at once collapsed and the bottom fell to the ground."

Pg 402

He fails, as do so many other critics of this theory, to distinguish the difference between that portion of the sand which acts as so-called "centering" and that which goes to make up the sustaining arch. The dislodgment of any large portion of this "centering" naturally causes collapse, unless it is caught, in which case the void in the "centering" is filled from the material in the sustaining arch, and this, in turn, is filled from that above, and so on, until the stability of each arch is in turn finally established. This, however, does not mean that, during the process of establishing this equilibrium of the arch stresses, there is no arching action of any of the material above, but only that some of the so-called arches are temporarily sustained by those below. That is, in effect, each area of the material above becomes, in turn, a dependent, an independent, and finally an interdependent arch.

If Mr. Goodrich's experience has led him to examine any large number of tunnel arches or brick sewers, he will have noted in many of them longitudinal cracks at the soffits of the arches and perhaps elsewhere. These result from three causes:

First.—In tunneling, there is more or less loss of material, while, in back-filling, the material does not at first reach its final compactness. Therefore, in adjusting itself to normal conditions, this material causes impact loads to come upon the green arch, and these tend to crack it.

Second.—No matter how tightly a brick or other arch is keyed in, there must always be some slight subsidence when the "centers" are struck. This, again, results in a shock, or impact loading, to the detriment of the arch.

Third.—The most prolific cause, however, is that in tunneling, as well as in back-filling open cuts, the material backing up the haunches is more or less loosened and therefore is not at first compact enough to prevent the spreading of the haunches when the load comes on the arch. This causes cracking, but, as soon as the haunches have been pressed out against the solid material, the cracking usually ceases, unless the pressure has been sufficiently heavy to cause collapse.

An interesting example of this was noted in the Joralemon Street branch of the Rapid Transit Tunnel, in Brooklyn, in which a great many of the cast-iron rings were cracked under the crown of the arch, during construction; but, in spite of this, they sustained, for more than two years, a loading which, according to Mr. Goodrich, was continually increasing. In other words, the cracked arch sustained a greater loading than that which cracked the plates during construction, according to his theory, as noted in the following quotation:

Pg 403

"But it should be equally conceded by the advocates of the existence of such action that changes in humidity, due to moving water, vibration, and appreciable viscosity, etc., will invariably destroy this action in time."

As to the correctness of this theory Mr. Goodrich would probably have great difficulty in convincing naturalists, who are aware that many animals live in enlarged burrows the stability of which is dependent on the arching action of the earth; in fact, many of these burrows have entrances under water. He would also have some difficulty in convincing those experienced miners who, after a cave-in, always wait until the ground has settled and compacted itself before tunneling, usually with apparent safety, over the scene of the cave-in.

The writer quotes as follows from Mr. Goodrich's discussion:

"In any case, no arch action can be brought into play until a certain amount of settlement has taken place so as to bring the particles into closer contact, and in such a way that the internal stresses are practically those only of compression, and the shearing stresses are within the limits possible for the material in question."

Further:

"Consequently, an almost infinitesimal settlement of the 'centering' may cause the complete destruction of an arch of earth."

And further:

"On the other hand, it is believed that the author's statement, as to the 'tendency of marbles to arch,' * * * should be qualified by the addition of the words, 'only when a certain amount of deflection has taken place so as to bring the arch into action.'"

In a large measure the writer agrees with the first and last quotations, but sees no reason to endorse the second, as it is impossible to consider any arch being built which does not settle slightly, at least, when the "centers" are struck.

Regarding his criticism of the lack of arching action in balls or marbles, he seems to reason that the movement of the marbles would destroy the arch action. It is very difficult for the writer to conceive how it would be possible for balls or marbles to move when confined as they would be confined if the earth were composed of them instead of its present ingredients, and under the same conditions otherwise. Mr. Goodrich can demonstrate the correctness of the writer's theories, however, if he will repeat the writer's Experiment No. 3, with marbles, with buckshot, and with dry sand. He is also advised to make the experiment with sand and water, described by the writer, and is assured that, if he will see that the washers are absolutely tight before putting the water into the box, he can do this without bringing about the collapse of the arch; the only essential condition is that the bottom shall be keyed up tightly, so as not to allow the escape of any sand. He is also referred to the two photographs, [Plate XXIV](#), illustrating the writer's first experiment, showing how increases in the loading resulted in compacting the material of the arch and in the consequent lowering of the false bottom. As long as the exposed sand above this false bottom had cohesion enough to prevent the collapse of the "centering," this arch could have been loaded with safety up to the limits of the compressive strength of the sand.

Pg 404

To quote again from Mr. Goodrich:

"Furthermore, the author's reason for bisecting the angle between the vertical and the angle of repose of the material, when he undertakes to determine the thickness of key, is not obvious. This assumption is shown to be absurd when carried to either limit, for when the angle of repose equals zero, as is the case with water, this method would give a definite thickness of key, while there can be absolutely no arch action possible in such a case; and, when the angle of repose is 90°, as may be assumed in the case of rock, this method would give an infinite thickness of key, which is again seen to be absurd."

Mr. Goodrich assumes that water or liquid has an angle of repose equal to zero, which is true, but the writer's assumptions applied only to solid material, and the liquid gives an essentially different condition of pressure, as shown by a careful reading of the paper. In solid rock Mr. Goodrich assumes an angle of repose equal to 90°, for which there is no authority; that is, solid rock has no known angle of repose. In order to carry these assumptions to a definite conclusion, we must assume for that material with an angle of repose of 90° some solid material which has weight but no thrust, such as blocks of ice piled vertically. In this case Mr. Goodrich can readily see that there will be no arching action over the structure, and that the required thickness of key would be infinite. As to the other case, it is somewhat difficult to conceive of

a solid with an angle of repose of zero; aqueous material does not fulfill this condition, as it is either a liquid or a combination of water and solid material. The best illustration, perhaps, would be to assume a material composed of iron filings, into which had been driven a powerful magnet, so that the iron filings would be drawn horizontally in one direction. It is easy to conceive, then, that in tunneling through this material there would be no necessity for holding up the roof; the definite thickness of key given, as being at the point of intersection of two 45° angles, would be merely a precautionary measure, and would not be required in practice.

It is thus seen that both these conditions can be fulfilled with practical illustrations; that is, for an angle of repose of 90°, that material which has weight and no thrust, and for an angle of repose of zero, that solid material which has thrust but no weight.

Pg 405

Mr. Goodrich says the author has given no experiments to prove his statement that the arch thrust is greater in dryer sand. If Mr. Goodrich will make the experiment partially described as Experiment No. 3, with absolutely dry sand, and with moist sand, and on a scale large enough to eliminate cohesion, he will probably find enough to convince him that in this assumption the writer is correct. At the same time, the writer has based his theory in this regard on facts which are not entirely conclusive, and his mind is open as to what future experiments on a large scale may develop. It is very probable, however, that an analytical and practical examination of the English experiments noted on pages 379 and 380, will be sufficient to develop this fact conclusively.

The writer is forced to conclude that some of the criticisms by Mr. Goodrich result from a not too careful reading of the paper. For instance, he states:

"It is conceded' (line 2, p. [357](#), for example) when the writer, for one, has not even conceded the accuracy of the assumptions."

A more careful reading would have shown Mr. Goodrich that this concession was one of the writer's as to certain pressures against or on tunnels, and, if Mr. Goodrich does not concede this, he is even more radical than the writer.

And again:

"'Nor can anyone * * * doubt that the top timbers are stressed more heavily than those at the bottom' is emphatically doubted and earnestly denied by the writer."

It is unfortunate that Mr. Goodrich failed to make the complete quotation, which reads:

"Nor can anyone, looking at [Fig. 5](#), doubt," etc.

A glance at [Fig. 5](#) will demonstrate that, under conditions there set forth, the writer is probably correct in his assertion as relating to that particular instance. Further:

"For instance, the author's well-known theory that the pressures against retaining walls are a maximum at the top and decrease to zero at the bottom, is in absolute contradiction to the results of experiments conducted on a large scale by the writer on the new reinforced concrete retaining wall near the St. George Ferry, on Staten Island."

The writer's "well-known theory that pressures against retaining walls are a maximum at the top and decrease to zero at the bottom" applies only to pressures exerted by absolutely dry and normally dry material, and it seems to him that this so-called theory is capable of such easy demonstration, by the simple observation of any bracing in a deep trench in material of this class, that it ought to be accepted as at least safer than the old theory which it reverses. As to this "well-known theory" in material subject to water pressure, a careful reading of the paper, or an examination of [Fig. 12](#) and its accompanying text, or an examination of Table 1, will convince Mr. Goodrich that, under the writer's analysis, this pressure does not decrease to zero at the bottom, but that in soft materials it may be approximately constant all the way down, while, in exceptionally soft material, conditions may arise where it may increase toward the bottom. The determination should be made by taking the solid material and drying it sufficiently so that water does not flow or seep from it. When this material is then compacted to the condition in which it would be in its natural state, its angle of repose may be measured, and may be found to be as high as 60 degrees. The very fine matter should then be separated from the coarser material, and the latter weighed, to determine its proportion. Subtracting this from the total, the remainder could be credited to "aqueous matter." It is thus seen that with a material when partially dried in which the natural angle of repose might be 60°, and in which the percentage of water or aqueous matter when submerged might be 60%, there would be an increase of pressure toward the bottom.

Pg 406

The writer does not know the exact nature of the experiments made at St. George's Ferry by Mr. Goodrich, but he supposes they were measurements of pressures on pistons through holes in the sheeting. He desires to state again that he cannot regard such experiments as conclusive, and believes that they are of comparative value only, as such experiments do not measure in any large degree the pressure of the solid material but only all or a portion of the so-called aqueous matter, that is, the liquid and very fine material which flows with it. Thus it is well known that, during the construction of the recent Hudson and North River Tunnels, pressures were tested in the silt, some of which showed that the silt exerted full hydrostatic pressure. At the same time, W.I. Aims, M. Am. Soc. C. E., stated in a public lecture, and recently also to the writer, that in 1890 he made some tests of the pressure of this silt in normal air for the late W.R. Hutton, M. Am. Soc. C. E. A hole, 12 in. square, was cut through the brickwork and the iron lining, just back of the lock in the north tube (in normal air), and about 1000 ft. from the New Jersey shore. It was found that the silt had become so firm that it did not flow into the opening. Later, a 4-in. collar and piston were built into the opening, and, during a period covering at least 3 months, constant observations showed that no pressure came upon it; in fact, it was stated that the piston was frequently worked back and forth to induce pressure, but no response was obtained during all this period. The conclusion must then be drawn that when construction, with its attendant disturbance, has stopped, the solid material surrounding structures tends to compact itself more or less, and solidify, according as it is more or less porous, forming in many instances what may be virtually a compact arch shutting off a large percentage of the normal, and some percentage even of the aqueous, pressure.

That the pressure of normally dry material cannot be measured through small openings can be verified by any one who will examine such material back of bracing showing evidences of heavy pressure. The investigator will find that, if this material is free from water pressure, paper stuffed lightly into small openings will hold back indefinitely material which in large masses has frequently caused bracing to buckle and sheeting planks to bend and break; and the writer reiterates that such experiments should be made in trenches sheeted with horizontal sheeting bearing against short vertical rangers and braces giving horizontal sections absolutely detached and independent of each other. In no other way can such experiments be of real value (and even then only when made on a large scale) to determine conclusively the pressure of earth on trenches.

As to the questions of the relative thrust of materials under various angles of repose, and of the necessity of dividing by the tangent, etc.; these, to the writer, seem to be merely the solution of problems in simple graphics.

The writer believes that if Mr. Goodrich will make, even on a small scale, some of the experiments noted by the writer, he will be convinced that many of the assumptions which he cannot at present endorse are based on fact, and his co-operation will be welcomed with the greatest interest. Among the experiments which he is asked to make is the one in dry sand, noted as Experiment No. 3, whereby it can be shown very conclusively that additional back-fill will result in increased arching stability, on an arch which would collapse under lighter loading.

The writer is indebted to Mr. Goodrich for pointing out some errors in omission and in typography (now corrected), and for his hearty concurrence in some of the assumptions which the writer believed would meet with greatest disapproval.

In reply to Mr. Pruyn and Mr. Gregory, the writer assumed that the piston area in Experiment No. 6 should be reduced only by the actual contact of material with it. If this material in contact should be composed of theoretical spheres, resulting in a contact with points only, then the theoretical area reduced should be in proportion to this amount only. The writer does not believe, however, that this condition exists in practice, but thinks that the area is reduced very much more than by the actual theoretical contact of the material. He sees no reason, as far as he has gone, to doubt the accuracy of the deductions from this experiment.

Regarding the question of the length of time required to raise the piston, he does not believe that the position of his critics is entirely correct in this matter; that is, it must either be conceded that the piston area is cut off from the source of pressure, or that it is in contact with it through more or less minute channels of water. If it is cut off, then the writer's contention is proved without the need of the experiment, and it is therefore conclusive that a submerged tunnel is not under aqueous pressure or the buoyant action of water. If, on the other hand, the water is in contact through channels bearing directly upon the piston and leading to the clear water chamber, any increase in pressure in the water chamber must necessarily result in a virtually instantaneous increase of the pressure against the piston, and therefore the action on the latter should follow almost immediately. In all cases during the experiments the piston did not respond until the pressure was approximately twice as great as required in clear water, therefore the writer must conclude either that the experiments proved it conclusively or that his assumption is proved without the necessity of the experiments. That is, the pressure is virtually not in evidence until the piston has commenced to move.

Mr. Pruyn has added valuable information in his presentation of data obtained from specific tests of the bearing value of, and friction on, hollow steel piles. These data largely corroborate tests and observations by the writer, and are commended to general attention.

Mr. Carter's information is also of special interest to the writer, as much of it is in the line of confirming his views. Mr. Carter does not yet accept the theory of increased pressure toward the top, but if he will examine or experiment with heavy bracing in deep trenches in clear sand, or material with well-defined angles of repose, he will probably find much to help him toward the acceptance of this view.

The writer regrets that he has not now the means or appliances for further experiments with the piston chamber, but he does not believe that reliable results could be obtained in broken stone with so small a piston, as it is possible that the point of one stone only might be in contact with the piston. This would naturally leave the base exposed almost wholly to a clear water area. He does not believe, however, that in practice the laying of broken stone under inverts will materially change the ultimate pressure unless its cross-section represents a large area.

Mr. Perry will find the following on page [369](#):

"It should be noted also that although the area subject to pressure is diminished, the pressure on the area remaining corresponds to the full hydrostatic head, as would be shown by the pressure on an air gauge."

This, of course, depends on the porosity of the material and the friction the water meets in passing through it.

As to Mr. Thomson's discussion, the writer notes with regret two points: (a) that specific data are not given in many of the interesting cases of failures of certain structures or bracing; and (b), that he has not in all cases a clear understanding of the paper. For instance, the writer has not advocated the omission of bottom bracing or sheeting. He has seen many instances where it has been, or could have been, safely omitted, but he desires to make it clear that he does not under any circumstances advocate its omission in good work; but only that, in well-designed bracing, its strength may be decreased as it approaches the bottom.

Reference is again made to the diagram, [Fig. 12](#), which shows that, in most cases of coffer-dams in combined aqueous and earth pressure, there may be nearly equal, and in some cases even greater, loading toward the bottom.

The writer also specifically states that in air the difference between aqueous and earth pressure is plainly noted by the fact that bracing is needed so frequently to hold back the earth while the air is keeping out

the water.

The lack of specific data is especially noticeable in the account of the rise of the 6-ft. conduit at Toronto. It would be of great interest to know with certainty the weight of the pipe per foot, and whether it was properly bedded and properly back-filled. In all probability the back-filling over certain areas was not properly done, and as the pipe was exposed to an upward pressure of nearly 1600 lb. per ft., with probably only 500 or 600 lb. of weight to counterbalance it, it can readily be seen that it did not conform with the writer's general suggestion, that structures not compactly, or only partially, buried, should have a large factor of safety against the upward pressure. Opposed to Mr. Thomson's experience in this instance is the fact that oftentimes the tunnels under the East River approached very close to the surface, with the material above them so soupy (owing to the escape of compressed air) that their upper surfaces were temporarily in water, yet there was no instance in which they rose, although some of them were under excessive buoyant pressure.

It is also of interest to note, from the papers descriptive of the North River Tunnel, that, with shield doors closed, the shield tended to rise, while by opening the doors to take in muck the shield could be brought down or kept down. The writer concurs with those who believe that the rising of the shield with closed doors was due to the slightly greater density of the material below, and was not in any way due to buoyancy.

Concerning the collapse of the bracing in the tunnel built under a side-hill, the writer believes it was due to the fact that it was under a sliding side-hill, and that, if it had been possible to have back-filled over and above this tunnel to a very large extent, this back-fill would have resulted in checking the sliding of material against the tunnel, and the work would thereafter have been done with safety. This is corroborated by Mr. Thomson's statement that the tunnel was subsequently carried through safely by going farther into the hill.

Pg 410

As to the angle of repose, Mr. Thomson seems to feel that its determination is so often impracticable that it is not to be relied on; and yet all calculations pertaining to earth pressure must be based on this factor. The writer believes that the angle of repose is not difficult to determine, and that observations of, and experiments on, exposed banks in similar material, and general experience in relation thereto, will enable one to determine it in nearly all cases within such reasonably accurate limits that only a small margin of safety need be added.

Engineers are sent to Europe to study sewage disposal, water purification, transit problems, etc., but are rarely sent to an adjoining county or State to look at an exposed bank, which would perhaps solve a vexed problem in bracing and result in great economy in the design of permanent structures.

Mr. Thomson's general views seem to indicate that much of the subject matter noted in the paper relates to unsolvable problems, for it appears that in many cases he believes the Engineer to be dependent on his educated guess, backed perhaps by the experienced guess of the foreman or practical man. The writer, on the contrary, believes that every problem relating to work of this class is capable of being solved, within reasonably accurate limits, and that the time is not far distant when the engineer, with his study of conditions, and samples of material before him, will be able to solve his earth pressure and earth resistance problems as accurately as the bridge engineer, with his knowledge of structural materials, solves bridge problems.

The writer, in the course of his experience, has met with or been interested in the solution of many problems similar to the following:

What difference in timbering should be made for a tunnel in ordinary, normally dry ground at a depth of 20 ft. to the roof, as compared with one at a depth of 90 ft.?

What difference in timbering or in permanent design should be made for a horizontally-sheeted shaft, 5 ft. square, going to a depth of 45 ft. and one 25 by 70 ft., for instance, going to the same depth, assuming each to be braced and sheeted horizontally with independent bracing?

What allowance should be made for the strength of interlock, assuming that a circular bulkhead of sand, 30 ft. in diameter, is to be carried by steel sheet-piling exposed around the outside for a depth of 40 ft.?

What average pressure per square foot of area should be required to drive a section of a 3 by 15-ft. roof shield, as compared with the pressure needed to drive the whole roof shield with an area four times as great?

Pg 411

To what depth could a 12 by 12-in. timber be driven, under gradually added pressure, up to 60 tons, for instance, in normal sand?

What frictional resistance should be assumed on a hollow, steel, smooth-bore pile which had been driven through sharp sand and had penetrated soft, marshy material the bearing resistance of which was practically valueless?

What allowance should be made for the buoyancy of a tunnel 20 ft. in diameter, the top of which was buried to a depth of 20 ft. in sand above which there was 40 ft. of water?

It is believed by the writer that most of the authorities are silent as to the solution of problems similar to the above, and it is because of this lack of available data that he has directed his studies to them. The belief that the results of these studies, together with such observations and experiments as relate thereto, may be of interest, has caused him to set them forth in this paper.

He desires to state his belief that if problems similar to the above were given for definite solution, not based on ordinary safe practice, and without conference, to a number of engineers prominently interested in such matters, the results would vary so widely as to convince some of the critics of this paper that the greater danger lies rather in the non-exploration of such fields than in the setting forth of results of exploration which may appear to be somewhat radical.

Further, if these views result in stimulating enough interest to lead to the hope that eventually the "Pressure, Resistance, and Stability" of ground under varying conditions will be known within reasonably

accurate limits and tabulated, the writer will feel that his efforts have not been in vain.

FOOTNOTES:

[H] "Lateral Earth Pressures and Related Phenomena," *Transactions*, Am. Soc. C. E., Vol. LIII, p. 272.

*** END OF THE PROJECT GUTENBERG EBOOK PRESSURE, RESISTANCE, AND STABILITY OF EARTH

Updated editions will replace the previous one—the old editions will be renamed.

Creating the works from print editions not protected by U.S. copyright law means that no one owns a United States copyright in these works, so the Foundation (and you!) can copy and distribute it in the United States without permission and without paying copyright royalties. Special rules, set forth in the General Terms of Use part of this license, apply to copying and distributing Project Gutenberg™ electronic works to protect the PROJECT GUTENBERG™ concept and trademark. Project Gutenberg is a registered trademark, and may not be used if you charge for an eBook, except by following the terms of the trademark license, including paying royalties for use of the Project Gutenberg trademark. If you do not charge anything for copies of this eBook, complying with the trademark license is very easy. You may use this eBook for nearly any purpose such as creation of derivative works, reports, performances and research. Project Gutenberg eBooks may be modified and printed and given away—you may do practically ANYTHING in the United States with eBooks not protected by U.S. copyright law. Redistribution is subject to the trademark license, especially commercial redistribution.

START: FULL LICENSE THE FULL PROJECT GUTENBERG LICENSE PLEASE READ THIS BEFORE YOU DISTRIBUTE OR USE THIS WORK

To protect the Project Gutenberg™ mission of promoting the free distribution of electronic works, by using or distributing this work (or any other work associated in any way with the phrase “Project Gutenberg”), you agree to comply with all the terms of the Full Project Gutenberg™ License available with this file or online at www.gutenberg.org/license.

Section 1. General Terms of Use and Redistributing Project Gutenberg™ electronic works

1.A. By reading or using any part of this Project Gutenberg™ electronic work, you indicate that you have read, understand, agree to and accept all the terms of this license and intellectual property (trademark/copyright) agreement. If you do not agree to abide by all the terms of this agreement, you must cease using and return or destroy all copies of Project Gutenberg™ electronic works in your possession. If you paid a fee for obtaining a copy of or access to a Project Gutenberg™ electronic work and you do not agree to be bound by the terms of this agreement, you may obtain a refund from the person or entity to whom you paid the fee as set forth in paragraph 1.E.8.

1.B. “Project Gutenberg” is a registered trademark. It may only be used on or associated in any way with an electronic work by people who agree to be bound by the terms of this agreement. There are a few things that you can do with most Project Gutenberg™ electronic works even without complying with the full terms of this agreement. See paragraph 1.C below. There are a lot of things you can do with Project Gutenberg™ electronic works if you follow the terms of this agreement and help preserve free future access to Project Gutenberg™ electronic works. See paragraph 1.E below.

1.C. The Project Gutenberg Literary Archive Foundation (“the Foundation” or PGLAF), owns a compilation copyright in the collection of Project Gutenberg™ electronic works. Nearly all the individual works in the collection are in the public domain in the United States. If an individual work is unprotected by copyright law in the United States and you are located in the United States, we do not claim a right to prevent you from copying, distributing, performing, displaying or creating derivative works based on the work as long as all references to Project Gutenberg are removed. Of course, we hope that you will support the Project Gutenberg™ mission of promoting free access to electronic works by freely sharing Project Gutenberg™ works in compliance with the terms of this agreement for keeping the Project Gutenberg™ name associated with the work. You can easily comply with the terms of this agreement by keeping this work in the same format with its attached full Project Gutenberg™ License when you share it without charge with others.

1.D. The copyright laws of the place where you are located also govern what you can do with this work. Copyright laws in most countries are in a constant state of change. If you are outside the United States, check the laws of your country in addition to the terms of this agreement before downloading, copying, displaying, performing, distributing or creating derivative works based on this work or any other Project Gutenberg™ work. The Foundation makes no representations concerning the copyright status of any work in any country other than the United States.

1.E. Unless you have removed all references to Project Gutenberg:

1.E.1. The following sentence, with active links to, or other immediate access to, the full Project Gutenberg™ License must appear prominently whenever any copy of a Project Gutenberg™ work (any work on which the phrase “Project Gutenberg” appears, or with which the phrase “Project Gutenberg” is associated) is accessed, displayed, performed, viewed, copied or distributed:

This eBook is for the use of anyone anywhere in the United States and most other parts of the world at no cost and with almost no restrictions whatsoever. You may copy it, give it away or re-use it under the terms of the Project Gutenberg License included with this eBook or online at www.gutenberg.org. If you are not located in the United States, you will have to check the laws of the country where you are located before using this eBook.

1.E.2. If an individual Project Gutenberg™ electronic work is derived from texts not protected by U.S. copyright law (does not contain a notice indicating that it is posted with permission of the copyright holder), the work can be copied and distributed to anyone in the United States without paying any fees or charges. If you are redistributing or providing access to a work with the phrase "Project Gutenberg" associated with or appearing on the work, you must comply either with the requirements of paragraphs 1.E.1 through 1.E.7 or obtain permission for the use of the work and the Project Gutenberg™ trademark as set forth in paragraphs 1.E.8 or 1.E.9.

1.E.3. If an individual Project Gutenberg™ electronic work is posted with the permission of the copyright holder, your use and distribution must comply with both paragraphs 1.E.1 through 1.E.7 and any additional terms imposed by the copyright holder. Additional terms will be linked to the Project Gutenberg™ License for all works posted with the permission of the copyright holder found at the beginning of this work.

1.E.4. Do not unlink or detach or remove the full Project Gutenberg™ License terms from this work, or any files containing a part of this work or any other work associated with Project Gutenberg™.

1.E.5. Do not copy, display, perform, distribute or redistribute this electronic work, or any part of this electronic work, without prominently displaying the sentence set forth in paragraph 1.E.1 with active links or immediate access to the full terms of the Project Gutenberg™ License.

1.E.6. You may convert to and distribute this work in any binary, compressed, marked up, nonproprietary or proprietary form, including any word processing or hypertext form. However, if you provide access to or distribute copies of a Project Gutenberg™ work in a format other than "Plain Vanilla ASCII" or other format used in the official version posted on the official Project Gutenberg™ website (www.gutenberg.org), you must, at no additional cost, fee or expense to the user, provide a copy, a means of exporting a copy, or a means of obtaining a copy upon request, of the work in its original "Plain Vanilla ASCII" or other form. Any alternate format must include the full Project Gutenberg™ License as specified in paragraph 1.E.1.

1.E.7. Do not charge a fee for access to, viewing, displaying, performing, copying or distributing any Project Gutenberg™ works unless you comply with paragraph 1.E.8 or 1.E.9.

1.E.8. You may charge a reasonable fee for copies of or providing access to or distributing Project Gutenberg™ electronic works provided that:

- You pay a royalty fee of 20% of the gross profits you derive from the use of Project Gutenberg™ works calculated using the method you already use to calculate your applicable taxes. The fee is owed to the owner of the Project Gutenberg™ trademark, but he has agreed to donate royalties under this paragraph to the Project Gutenberg Literary Archive Foundation. Royalty payments must be paid within 60 days following each date on which you prepare (or are legally required to prepare) your periodic tax returns. Royalty payments should be clearly marked as such and sent to the Project Gutenberg Literary Archive Foundation at the address specified in Section 4, "Information about donations to the Project Gutenberg Literary Archive Foundation."
- You provide a full refund of any money paid by a user who notifies you in writing (or by e-mail) within 30 days of receipt that s/he does not agree to the terms of the full Project Gutenberg™ License. You must require such a user to return or destroy all copies of the works possessed in a physical medium and discontinue all use of and all access to other copies of Project Gutenberg™ works.
- You provide, in accordance with paragraph 1.F.3, a full refund of any money paid for a work or a replacement copy, if a defect in the electronic work is discovered and reported to you within 90 days of receipt of the work.
- You comply with all other terms of this agreement for free distribution of Project Gutenberg™ works.

1.E.9. If you wish to charge a fee or distribute a Project Gutenberg™ electronic work or group of works on different terms than are set forth in this agreement, you must obtain permission in writing from the Project Gutenberg Literary Archive Foundation, the manager of the Project Gutenberg™ trademark. Contact the Foundation as set forth in Section 3 below.

1.F.

1.F.1. Project Gutenberg volunteers and employees expend considerable effort to identify, do copyright research on, transcribe and proofread works not protected by U.S. copyright law in creating the Project Gutenberg™ collection. Despite these efforts, Project Gutenberg™ electronic works, and the medium on which they may be stored, may contain "Defects," such as, but not limited to, incomplete, inaccurate or corrupt data, transcription errors, a copyright or other intellectual property infringement, a defective or damaged disk or other medium, a computer virus, or computer codes that damage or cannot be read by your equipment.

1.F.2. LIMITED WARRANTY, DISCLAIMER OF DAMAGES - Except for the "Right of Replacement or Refund" described in paragraph 1.F.3, the Project Gutenberg Literary Archive Foundation, the owner of the Project Gutenberg™ trademark, and any other party distributing a Project Gutenberg™ electronic work under this agreement, disclaim all liability to you for damages, costs and expenses,

including legal fees. YOU AGREE THAT YOU HAVE NO REMEDIES FOR NEGLIGENCE, STRICT LIABILITY, BREACH OF WARRANTY OR BREACH OF CONTRACT EXCEPT THOSE PROVIDED IN PARAGRAPH 1.F.3. YOU AGREE THAT THE FOUNDATION, THE TRADEMARK OWNER, AND ANY DISTRIBUTOR UNDER THIS AGREEMENT WILL NOT BE LIABLE TO YOU FOR ACTUAL, DIRECT, INDIRECT, CONSEQUENTIAL, PUNITIVE OR INCIDENTAL DAMAGES EVEN IF YOU GIVE NOTICE OF THE POSSIBILITY OF SUCH DAMAGE.

1.F.3. LIMITED RIGHT OF REPLACEMENT OR REFUND - If you discover a defect in this electronic work within 90 days of receiving it, you can receive a refund of the money (if any) you paid for it by sending a written explanation to the person you received the work from. If you received the work on a physical medium, you must return the medium with your written explanation. The person or entity that provided you with the defective work may elect to provide a replacement copy in lieu of a refund. If you received the work electronically, the person or entity providing it to you may choose to give you a second opportunity to receive the work electronically in lieu of a refund. If the second copy is also defective, you may demand a refund in writing without further opportunities to fix the problem.

1.F.4. Except for the limited right of replacement or refund set forth in paragraph 1.F.3, this work is provided to you 'AS-IS', WITH NO OTHER WARRANTIES OF ANY KIND, EXPRESS OR IMPLIED, INCLUDING BUT NOT LIMITED TO WARRANTIES OF MERCHANTABILITY OR FITNESS FOR ANY PURPOSE.

1.F.5. Some states do not allow disclaimers of certain implied warranties or the exclusion or limitation of certain types of damages. If any disclaimer or limitation set forth in this agreement violates the law of the state applicable to this agreement, the agreement shall be interpreted to make the maximum disclaimer or limitation permitted by the applicable state law. The invalidity or unenforceability of any provision of this agreement shall not void the remaining provisions.

1.F.6. INDEMNITY - You agree to indemnify and hold the Foundation, the trademark owner, any agent or employee of the Foundation, anyone providing copies of Project Gutenberg™ electronic works in accordance with this agreement, and any volunteers associated with the production, promotion and distribution of Project Gutenberg™ electronic works, harmless from all liability, costs and expenses, including legal fees, that arise directly or indirectly from any of the following which you do or cause to occur: (a) distribution of this or any Project Gutenberg™ work, (b) alteration, modification, or additions or deletions to any Project Gutenberg™ work, and (c) any Defect you cause.

Section 2. Information about the Mission of Project Gutenberg™

Project Gutenberg™ is synonymous with the free distribution of electronic works in formats readable by the widest variety of computers including obsolete, old, middle-aged and new computers. It exists because of the efforts of hundreds of volunteers and donations from people in all walks of life.

Volunteers and financial support to provide volunteers with the assistance they need are critical to reaching Project Gutenberg™'s goals and ensuring that the Project Gutenberg™ collection will remain freely available for generations to come. In 2001, the Project Gutenberg Literary Archive Foundation was created to provide a secure and permanent future for Project Gutenberg™ and future generations. To learn more about the Project Gutenberg Literary Archive Foundation and how your efforts and donations can help, see Sections 3 and 4 and the Foundation information page at www.gutenberg.org.

Section 3. Information about the Project Gutenberg Literary Archive Foundation

The Project Gutenberg Literary Archive Foundation is a non-profit 501(c)(3) educational corporation organized under the laws of the state of Mississippi and granted tax exempt status by the Internal Revenue Service. The Foundation's EIN or federal tax identification number is 64-6221541. Contributions to the Project Gutenberg Literary Archive Foundation are tax deductible to the full extent permitted by U.S. federal laws and your state's laws.

The Foundation's business office is located at 809 North 1500 West, Salt Lake City, UT 84116, (801) 596-1887. Email contact links and up to date contact information can be found at the Foundation's website and official page at www.gutenberg.org/contact

Section 4. Information about Donations to the Project Gutenberg Literary Archive Foundation

Project Gutenberg™ depends upon and cannot survive without widespread public support and donations to carry out its mission of increasing the number of public domain and licensed works that can be freely distributed in machine-readable form accessible by the widest array of equipment including outdated equipment. Many small donations (\$1 to \$5,000) are particularly important to maintaining tax exempt status with the IRS.

The Foundation is committed to complying with the laws regulating charities and charitable donations in all 50 states of the United States. Compliance requirements are not uniform and it takes a considerable effort, much paperwork and many fees to meet and keep up with these requirements. We do not solicit donations in locations where we have not received written confirmation of compliance. To SEND DONATIONS or determine the status of compliance for any particular state visit www.gutenberg.org/donate.

While we cannot and do not solicit contributions from states where we have not met the solicitation requirements, we know of no prohibition against accepting unsolicited donations from donors in such states who approach us with offers to donate.

International donations are gratefully accepted, but we cannot make any statements concerning tax

treatment of donations received from outside the United States. U.S. laws alone swamp our small staff.

Please check the Project Gutenberg web pages for current donation methods and addresses. Donations are accepted in a number of other ways including checks, online payments and credit card donations. To donate, please visit: www.gutenberg.org/donate

Section 5. General Information About Project Gutenberg™ electronic works

Professor Michael S. Hart was the originator of the Project Gutenberg™ concept of a library of electronic works that could be freely shared with anyone. For forty years, he produced and distributed Project Gutenberg™ eBooks with only a loose network of volunteer support.

Project Gutenberg™ eBooks are often created from several printed editions, all of which are confirmed as not protected by copyright in the U.S. unless a copyright notice is included. Thus, we do not necessarily keep eBooks in compliance with any particular paper edition.

Most people start at our website which has the main PG search facility: www.gutenberg.org.

This website includes information about Project Gutenberg™, including how to make donations to the Project Gutenberg Literary Archive Foundation, how to help produce our new eBooks, and how to subscribe to our email newsletter to hear about new eBooks.