

**The Project Gutenberg eBook of Scientific American Supplement,
No. 717, September 28, 1889, by Various**

This ebook is for the use of anyone anywhere in the United States and most other parts of the world at no cost and with almost no restrictions whatsoever. You may copy it, give it away or re-use it under the terms of the Project Gutenberg License included with this ebook or online at www.gutenberg.org. If you are not located in the United States, you'll have to check the laws of the country where you are located before using this eBook.

Title: Scientific American Supplement, No. 717, September 28, 1889

Author: Various

Release date: February 12, 2006 [EBook #17755]

Language: English

Credits: Produced by Amy Cunningham, Juliet Sutherland and the
Online Distributed Proofreading Team at <http://www.pgdp.net>

*** START OF THE PROJECT GUTENBERG EBOOK SCIENTIFIC AMERICAN
SUPPLEMENT, NO. 717, SEPTEMBER 28, 1889 ***



Scientific American Supplement, Vol. XXVIII, No. 717.
Scientific American, established 1845.

NEW YORK, SEPTEMBER 28, 1889.

Scientific American Supplement, \$5 a year.
Scientific American and Supplement, \$7 a year.

**SCIENTIFIC AMERICAN
SUPPLEMENT NO. 717**

NEW YORK, SEPTEMBER 28, 1889.

Scientific American Supplement. Vol. XXVIII., No. 717.

Scientific American, established 1845.

Scientific American Supplement, \$5 a year.

Scientific American and Supplement, \$7 a year.

TABLE OF CONTENTS.

	PAGE
I. CIVIL ENGINEERING.—The Girard Hydraulic Railway.—One of the great curiosities of the Paris exposition, the almost frictionless railway, with sectional illustrations of its structure.—8 illustrations.	11451
II. ELECTRICITY.—Early Electric Lighting.—Electric lighting in Salem in 1859, a very curious piece of early history.	11458
Electric Motor for Alternating Currents.—A motor on an entirely new principle for the application of the alternating current with results obtained, and the economic outlook of the invention.	11458
Portable Electric Light.—A lamp for military and other use, in which the prime motor, including the boiler and the lamp itself, are carried on one carriage.—1 illustration.	11458

	The Electric Age.—By CHARLES CARLETON COFFIN.—A short <i>resume</i> of the initial achievements of modern electricity.	11458
III.	GEOLOGY.—The Fuels of the Future.—A prognosis of the future prospect of the world as regards a fuel supply, with a special reference to the use of natural gas.	11457
IV.	MISCELLANEOUS.—Preservation of Spiders for the Cabinet.—A method of setting up spiders for preservation in the cabinet, with formulæ of solutions used and full details of the manipulation.—1 illustration.	11461
	The Ship in the New French Ballet of the "Tempest."—A curious example of modern scenic perfection, giving the construction and use of an appliance of the modern ballet.—5 illustrations.	11450
V.	NAVAL ENGINEERING.—Crank and Screw Shafts of the Mercantile Marine.—By G. W. MANUEL.—This all-important subject of modern naval engineering treated in detail, illustrating the progress of the present day, the superiority of material and method of using it, with interesting practical examples.—1 illustration.	11448
	Experimental Aid in the Design of High Speed Steamships.—By D. P.—A plea for the experimental determination of the probable speed of ships, with examples of its application in practice.	11449
	Forging a Propeller Shaft.—How large steamer shafts are forged, with example of the operation as exhibited to the Shah of Persia at Brown & Co.'s works, Sheffield, England.—1 illustration.	11447
	The Naval Forges and Steel Works at St. Chamond.—The forging of a piece of ordnance from a 90 ton ingot of steel, an artistic presentation of the subject.—1 illustration.	11447
VI.	PHOTOGRAPHY.—The Pyro Developer with Metabisulphite of Potash.—By Dr. J. M. EDER.—A new addition to the pyro developer, with formulæ and results.	11462
VII.	PHYSICS.—Quartz Fibers.—A lecture by Mr. C. V. BOYS on his famous experiments of the production of microscopic fibers, with enlarged illustrations of the same, and a graphic account of the entire subject.—7 illustrations.	11452
	The Modern Theory of Light.—By Prof. OLIVER LODGE.—An abstract of a lecture by the eminent investigator and expositor of Prof. Hertz's experiments, giving a brief review of the present aspect of this absorbing question.	11459
VIII.	PHYSIOLOGY.—Heat in Man.—Experiments recently made by Dr. Loewy on the heat of the human system.—Described and commented on by Prof. ZUNTZ.	11461
IX.	SANITATION.—On Purification of Air by Ozone—with an Account of a New Method.—By Dr. B. W. RICHARDSON.—A very important subject treated in full, giving the past attempts in the utilization of ozone and a method now available.	11460
X.	TECHNOLOGY.—Alkali Manufactories.—Present aspect of the Leblanc process and the new process for the recovery of sulphur from its waste.	11457
	Dried Wine Grapes.—The preparation of the above wine on a large scale in California, with full details of the process adopted.	11461
	The Production of Ammonia from Coal.—By LUDWIG MOND.—A valuable review of this important industry, with actual working results obtained in carrying out a retort process.—2 illustrations.	11454
	Nature, Composition, and Treatment of Animal and Vegetable Fabrics.—The history of fabrics and fibers in the vegetable and animal world, their sources, applications, and treatments.	11453
	Walnut Oil.—By Thomas T. P. BRUCE WARREN.—An excellent oil for painters' use, with description of a simple method for preparing it on a small scale.	11462

THE NAVAL FORGES AND STEEL WORKS AT ST. CHAMOND.

With the idyls and historic or picturesque subjects that the Universal Exposition

gives us the occasion to publish, we thought we would make a happy contrast by selecting a subject of a different kind, by presenting to our readers Mr. Layraud's fine picture, which represents the gigantic power hammer used at the St. Chamond Forges and Steel Works in the construction of our naval guns. By the side of the machinery gallery and the Eiffel tower this gigantic apparatus is well in its place.

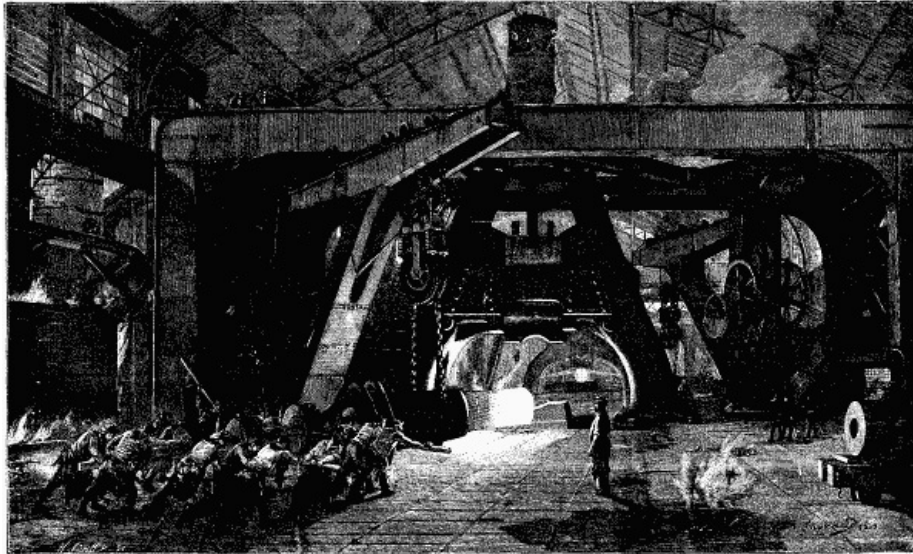

UNIVERSAL EXPOSITION—BEAUX ARTS—MARINE IRON AND STEEL WORKS AT SAINT CHAMOND—PRESENTATION OF A PIECE OF ORDNANCE UNDER THE VERTICAL HAMMER.—PICTURE BY M. JOSEPH LAYRAUD.

The following is the technical description that has been given to us to accompany our engraving: In an immense hall, measuring 260 ft. in length by 98 ft. in width, a gang of workmen has just taken from the furnace a 90 ton ingot for a large gun for an armor-clad vessel. The piece is carried by a steam crane of 140 tons power, and the men grouped at the maneuvering levers are directing this incandescent mass under the power hammer which is to shape it. This hammer, whose huge dimensions allow it to take in the object treated, is one of the largest in existence. Its striking mass is capable of reaching 100 tons, and the height of the fall is 16 ft. To the left of the hammer is seen a workman getting ready to set it in motion. It takes but one man to maneuver this apparatus, and this is one of the characteristic features of its construction.

The beginning of this hammer's operation, as well as the operations of the forge itself, which contains three other hammers of less power, dates back to 1879. It is with this great hammer that the largest cannons of the naval artillery—those of 16 inches—have been made (almost all of which have been manufactured at St. Chamond), and those, too, of 14, 13, and 12 inches. This is the hammer, too, that, a few months ago, was the first to be set at work on the huge 13 in. guns of new model, whose length is no less than 52 ft. in the rough.

Let us add a few more figures to this account in order to emphasize the importance of the installations which Mr. Layraud's picture recalls, and which our great French industry has not hesitated to establish, notwithstanding the great outlay that they necessitated. This huge hammer required foundations extending to a depth of 32 ft., and the amount of metal used in its construction was 2,640,000 pounds. The cost of establishing the works with all the apparatus contained therein was \$400,000.—*Le Monde Illustré*.

FORGING A PROPELLER SHAFT.

During the recent visit of the Shah of Persia to England, he visited, among other places, the great works of John Brown & Co., at Sheffield, and witnessed the pressing of a propeller shaft for one of the large ocean steamships. The operation is admirably illustrated in our engraving, for which we are indebted to the *Illustrated London News*.

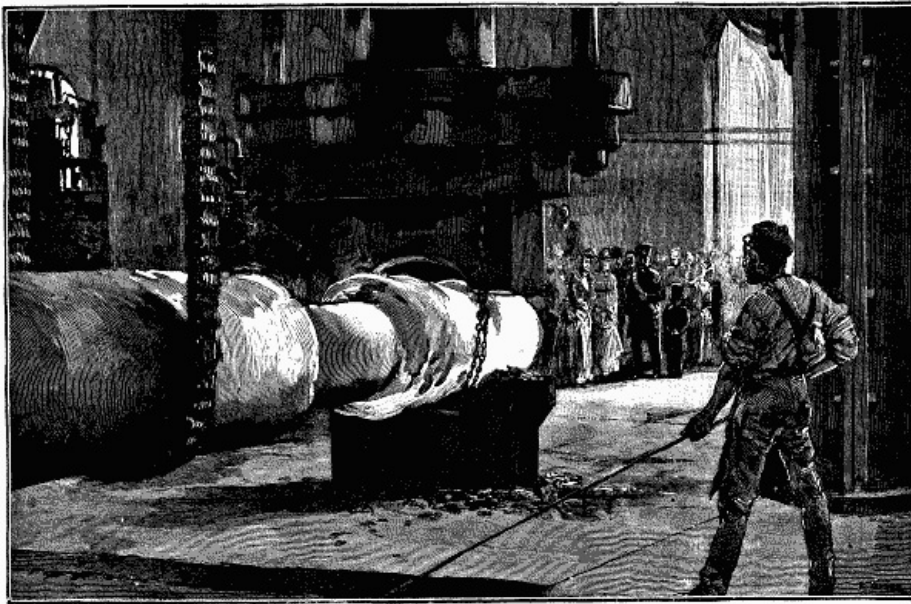

**PROPELLER SHAFT BEING PRESSED AT MESSRS. JOHN BROWN & CO.'S
WORKS, SHEFFIELD.**

CRANK AND SCREW SHAFTS OF THE MERCANTILE MARINE.¹

By G. W. MANUEL.

Being asked to read a paper before your institute, I have chosen this subject, as I think no part of the marine engine has given so much trouble and anxiety to the seagoing engineer; and from the list of shipping casualties in the daily papers, a large proportion seem due to the shafting, causing loss to the shipowner, and in some instances danger to the crew. My endeavor is to put some of the causes of these casualties before you, also some of the remedies that have tended to reduce their number. Several papers have been read on this subject, chiefly of a theoretical description, dealing with the calculations relating to the twisting and bending moments, effects of the angles of the cranks, and length of stroke—notably that read by Mr. Milton before the Institute of Naval Architects in 1881. The only *practical* part of this paper dealt with the possibility of the shafts getting out of line; and regarding this contingency Dr. Kirk said that "if superintendent engineers would only see that the bearings were kept in line, broken crank and other shafts would not be so much heard of." Of course this is one of those statements made in discussions of this kind, for what purpose I fail to see, and as far as my own experience goes is *misleading*; for having taken charge of steamers new from the builders' hands, when it is at least expected that these shafts would *be in line*, the crank shaft bearings heated very considerably, and *continued* to do so, rendering the duration of life of the crank shaft a short one; and though they were never what is termed out of line, the bearings could *not* be kept cool without the use of sea water, and occasionally the engines had to be stopped to cool and smooth up the bearing surfaces, causing delays, worry, and anxiety, for which the engineer in charge was in no way responsible. Happily this state of what I might call *uncertainties* is being gradually remedied, thanks being largely due to those engineers who have the skill to suggest improvements and the patience to carry them out against much opposition.

These improvements in many instances pertain to the engine builder's duties, and are questions which I think have been treated lightly; notably that of insufficient bearing surface, and one of the principal causes of hot bearings, whereby the oil intended for lubrication was squeezed out, and the metal surfaces brought too close in contact; and when bearings had a pressure of 200 lb. per square inch, it has been found that not more than 120 lb. per square inch should be exerted to keep them cool (this varies according to the material of which the bearing is composed), without having to use sea water and prevent them being ground down, and thus getting out of line. I have known a bearing in a new steamer, in spite of many gallons of oil wasted on it, wear down one-eighth of an inch in a voyage of only 6,000 miles, from insufficiency of bearing surface.

Several good rules are in use governing the strength of shafts, which treat of the diameter of the bearings only and angles of the cranks; and the engine builder, along with the ship owner, has been chary of increasing the surfaces by lengthening the bearings; for to do this means increase of space taken up fore and aft the vessel,

besides additional weight of engine. Engine builders all aim in competing to put their engines in less space than their rivals, giving same power and sometimes more. I think, however, this inducement is now more carefully considered, as it has been found more economical to give larger bearing surfaces than to have steamers lying in port, refitting a crank shaft, along with the consequences of heavy bills for salvage and repairs, also the risk of losing the steamer altogether. Proportioning the bearings to the weights and strains they have to carry has also been an improvement. The different bearings of marine engines were usually made alike in surface, irrespective of the work each had to do, with a view to economy in construction.

In modern practice the after bearings have more surface than the forward, except in cases where heavy slide-valve gear has to be supported, so that the wear down in the whole length of the shaft is equal, thus avoiding those alternate bending strains at the top and bottom of the stroke every revolution. Another improvement that has been successfully introduced, adding to the duration of life of crank shafts, is the use of white bearing metal, such as Parson's white brass, on which the shafts run smoothly with less friction and tendency to heat, so that, along with well proportioned surfaces, a number of crank shafts in the Peninsular and Oriental Co.'s service have not required lining up for eight years, and I hope with care may last till new boilers are required. Large and powerful steamers can be driven full speed from London to Australia and back without having any water on the bearings, using oil of only what is considered a moderate price, allowing the engineer in charge to attend to the economical working of both engines and boilers (as well as many other engines of all kinds now placed on board a large mail and passenger steamer), instead of getting many a drenching with sea water, and worried by close attention to one or two hot bearings all the watch. Compare these results with the following: In the same service in 1864, and with no blame to the engineer in charge, the crank shaft bearings of a screw steamer had to be lined up every five days at intermediate ports, through insufficient bearing surfaces. Sea water had continually to be used, resulting in frequent renewal of crank shaft. Steamers can now run 25,000 miles without having to lift a bearing, except for examination at the end of the voyage. I would note here that the form of the bearings on which the shafts work has also been much improved. They are made more of a *solid character*, the metal being more equally disposed *round* the shaft, and the use of gun metal for the main bearings is now fast disappearing. In large engines the only metals used are cast iron and white brass, an advantage also in reducing the amount of wear on the recess by corrosion and grinding where sea water was used often to a considerable extent.

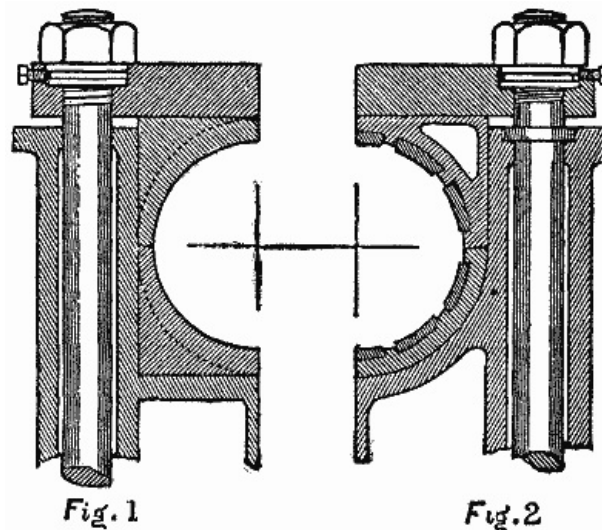

Figs. No. 1 and No. 2 show the design of the old and new main bearings, and, I think, require but little explanation. Most of you present will remember your feelings when, after a hot bearing, the brasses were found to be cracked at top and bottom, and the trouble you had afterward to keep these brasses in position. When a smoking hot bearing occurred, say in the heating of a crank pin, it had the effect of damaging the material of the shaft more or less, according to its original soundness, generally at the fillets in the angles of the cranks. For when the outer surface of the iron got hot, cold water, often of a low temperature, was suddenly poured on, and the hot iron, previously expanded, was suddenly contracted, setting up strains which in my opinion made a small tear transversely where the metal was *solid*; and where what is termed lamination flaws, due to construction, existed, these were extended in their natural direction, and by a repetition of this treatment these flaws became of such a serious character that the shafts had to be condemned, or actually gave way at sea. The introduction of the triple expansion engine, with the three cranks, gave better balance to the shaft, and the forces acting in the path of the crank pin, being better divided, caused more regular motion on the shaft, and so to the propeller. This is specially noticeable in screw steamers, and is taken advantage of by placing the

cabins further aft, nearer the propeller, the stern having but little vibration; the dull and heavy surging sound, due to unequal motions of the shaft in the two-crank engines, is exchanged for a more regular sound of less extent, and the power formerly wasted in vibrating the stern is utilized in propelling the vessel. In spite of all these improvements I have mentioned, there remains the serious question of defects in the material, due to variety of quality and the extreme care that has to be exercised in all the stages during construction of crank or other shafts built of iron. Many shafts have given out at sea and been condemned, through no other cause than *original defects* in their construction and material.

The process of welding and forging a crank shaft of large diameter now is to make it up of so many small *pieces*, the *best shafts* being made of what is termed scrap, representing thousands of small pieces of selected iron, such as cuttings of old iron boiler plates, cuttings off forgings, old bolts, horseshoes, angle iron, etc., all welded together, forged into billets, reheated, and rolled into bars. It is then cut into lengths, piled, and formed into slabs of suitable size for welding up into the shafts. No doubt this method is preferable to the old method of "fagoting," so called, as the iron bars were placed side by side, resembling a bundle of fagots of about 18 or 20 inches square.

The result was that while the outside bars would be welded, the inside would be improperly welded, or, the hammer being weak, the blow would be insufficient to secure the proper weld, and it was no uncommon thing for a shaft to break and expose the internal bars, showing them to be quite separate, or only partially united. This danger has been much lessened in late years by careful selection of the materials, improved methods of cleaning the scrap, better furnaces, the use of the most suitable fuels, and more powerful steam hammers. Still, with all this care, I think I may say there is not a shaft without flaws or defects, more or less, and when these flaws are situated in line of the greatest strains, and though you *may not* have a hot bearing, they often extend until the shaft becomes unseaworthy.

[Diagrams shown illustrated the various forms of flaws.] These flaws were not observable when the shafts were new, although carefully inspected. They gradually increased under strain, came to the outside, and were detected. Considerable loss fell upon the owners of these vessels, who were in no way to blame; nor could they recover any money from the makers of the shafts, who were alone to blame. I am pleased to state, and some of the members here present know, that considerable improvement has been effected in the use of better material than iron for crank shafts, by the introduction of a special mild steel, by Messrs. Vickers, Sons & Co., of Sheffield, and that instead of having to record the old familiar defects found in iron shafts, I can safely say no flaws have been observed, when new or during eight years running, and there are now twenty-two shafts of this mild steel in the company's service.

I may here state that steel was used for crank shafts in this service in 1863, as then manufactured in Prussia by Messrs. Krupp, and generally known as *Krupp's steel*, the tensile strength of which was about 40 tons per square inch, and though free from flaws, it was unable to stand the fatigue, and broke, giving little warning. It was of too brittle a nature, more resembling chisel steel. It was broken again under a falling weight of 10 cwt. with a 10 ft. drop = 12½ tons.

The mild steel now used was first tried in 1880. It possessed tensile strength of 24 to 25 tons per square inch. It was then considered advisable not to exceed this, and err rather on the safe side. This shaft has been in use eight years, and no sign of any flaw has been observed. Since then the tensile strength of mild steel has gradually been increased by Messrs. Vickers, the steel still retaining the elasticity and toughness to endure fatigue. This has only been arrived at by improvements in the manufacture and more powerful and better adapted hammers to forge it down from the large ingots to the size required. The amount of work they are now able to subject the steel to renders it more fit to sustain the fatigue such as that to be endured by a crank shaft. These ingots of steel can be cast up to 100 tons weight, and require powerful machines to deal with them. For shafts say of 20 inches diameter, the diameter of the ingot would be about 52 inches. This allows sufficient work to be put on the couplings, as well as the shaft. To make solid crank shafts of this material, say of 19 inches diameter, the ingot would weigh 42 tons, the forging, when completed, 17 tons, and the finished shaft 11¾ tons; so that you see there is 25 tons wasted before any machining is done, and 5¼ tons between the forging and finished shaft. This makes it very expensive for solid shafts of large size, and it is found better to make what is termed a *built shaft*; the cranks are a little heavier, and engine framings necessarily a little wider, a matter comparatively of little moment. I give you a rough drawing of the hydraulic hammer, or strictly speaking a *press*, used by Messrs. Vickers in forging down the ingots in shafts, guns, or other large work. This hammer can give a squeeze of 3,000 tons. The steel seems to yield under it like tough putty, and, unlike the steam hammer, there is no *jarring* on the material, and it is manipulated with the same ease as a small hammer by hydraulics.

The tensile strength of steel used for shafts having increased from 24 to 30 tons, and in some cases 31 tons, considering that this was 2 tons above that specified, and that we were approaching what may be termed *hard steel*, I proposed to the makers to test this material beyond the usual tests, viz., tensile, extension, and cold bending test. The latter, I considered, was much too easy for this fine material, as a piece of fair iron will bend cold to a radius of 1½ times its diameter or thickness, without fracture; and I proposed a test more resembling the fatigue that a crank shaft has sometimes to stand, and more worthy of this material; and in the event of its standing this successfully, I would pass the material of 30 or 31 tons tensile strength. Specimens of steel used in the shafts were cut off different parts—crank pins and main bearings—the shafts being built shafts) and roughly planed to 1½ inches square, and about 12 inches long. They were laid on the block as shown, and a cast iron block, fitted with a hammer head ½ ton weight, let suddenly fall 12 inches, the block striking the bar with a blow of about 4 tons. The steel bar was then turned upside down, and the blow repeated, reversing the piece every time until fracture was observed, and the bar ultimately broken. The results were that this steel stood 58 blows before showing signs of fracture, and was only broken after 77 blows. It is noticeable how many blows it stood after fracture. A bar of good wrought iron, undressed, of same dimensions, was tried, and broke the first blow. A bar cut from a piece of iron to form a large chain, afterward forged down and only filed to same dimensions, broke at 25 blows. I was well satisfied with the results, and considered this material, though possessing a high tensile strength, was in every way suitable for the construction and endurance required in crank shafts.

Sheet No. 1 shows you some particulars of these tests:

	Tensile Tons.	Elong. in 5"	Bend.	Fractured Blows.	Broke Blows.	Fall In.
A =	30.5	28 p. c.	Good	61	78	12

In order to test the comparative value of steel of 24¾ up to 35 tons tensile strength, I had several specimens taken from shafts tested in the manner described, which may be called a *fatigue* test. The results are shown on the same sheet:

B =	24½		Good	64	72	7
B	—	—	—	48	54	12
C =	27	25.9 p. c.	Good	76	81	12
D =	29.6	28.4 p. c.	Good	71	78	12
E =	30.5	28.9 p. c.	Good	58	77	12
F =	35.5	20 p. c.	Good	80	91	12

The latter was very tough to break. Specimen marked A shows one of these pieces of steel. I show you also fresh broken specimens which will give you a good idea of the beautiful quality of this material. These specimens were cut out of shafts made of Steel Co. of Scotland's steel. I also show you specimens of cold bending:

	Tensile Tons.	Elong. in. 5"	Bend.	Fractured Blows.	Broke Blows.	Fall In.
G =	30.9	27½ p. c.	Good	59	66	12
H =	29.3	30 p. c.	Good	66	90	12
I =	28.9	28.9 p. c.	Good	53	68	12

I think all of the above tests show that this material, when carefully made and treated with sufficient mechanical work on forging down from the ingot, is suitable up to 34 tons for crank shafts; how much higher it would be desirable to go is a question of superior excellence in material and manufacture resting with the makers. I would, however, remark that no allowance has been made by the Board of Trade or Lloyds for the excellence of this material above that of iron. I was interested to know how the material in the best iron shafts would stand this fatigue test compared with steel, and had some specimens of same dimensions cut out of iron shafts. The following are the results: Best iron, three good qualities, rolled into flat bars, cut and made into 4½ cwt. blooms.

J =	18.6	24.3 p. c.	Good	17	18	12
-----	------	------------	------	----	----	----

Made of best double rolled scrap, 4½ cwt. blooms.

K =	22	32½ p. c.	Good	21	32	12
-----	----	-----------	------	----	----	----

You will see from these results that steel stood this fatigue test, Vickers' 73 per cent. and Steel Co.'s 68 per cent., better than iron of the best quality for crank shafts; and I am of opinion that so long as we use such material as these for crank shafts, along

with the present rules, and give ample *bearing surface*, there will be few broken shafts to record.

I omitted to mention that built shafts, both of steel and iron, of large diameter, are now in general use, and with the excellent machines, and under special mechanics, are built up of five separate pieces in such a rigid manner that they possess all the solidity necessary for a crank shaft. The forgings of iron and steel being much smaller are capable of more careful treatment in the process of manufacture. These shafts, for large mail steamers, when coupled up, are 35 feet long, and weigh 45 tons. They require to be carefully coupled, some makers finishing the bearings in the lathe, others depend on the excellence of their work in each piece, and finish each complete. To insure the correct centering of these large shafts, I have had 6 in. dia. recesses $\frac{3}{4}$ inch deep turned out of each coupling to one gauge and made to fit one disk. Duplicate disks are then fitted in each coupling, and the centering is preserved, and should a spare piece be ever required, there is no trouble to couple correctly on board the steamer.

The propeller shaft is generally made of iron, and if made *not less* than the Board of Trade rules as regards diameter, of the best iron, and the gun metal liners carefully fitted, they have given little trouble; the principal trouble has arisen from defective fitting of the propeller boss. This shaft working in sea water, though running in lignum vitæ bearings, has a considerable wear down at the outer bearings in four or five years, and the shaft gets out of line. This wear has been lessened considerably by fitting the wood so that the grain is midway to the shaft, and with sufficient bearing surface these bearings have not required lining up for nine years. It is, however, a shaft that cannot be inspected except when in dry dock, and has to be disconnected from the propeller, and drawn inside for examination at periods suggested by experience. Serious accidents have occurred through want of attention to the examination of this shaft; when working in salt water, with liners of gun metal, galvanic action ensues, and extensive corrosion takes place in the iron at the ends of the brass liners, more especially if they are faced up at right angles to the shaft. Some engineers have the uncovered part of the shaft between the liners, inside the tube, protected against the sea water by winding over it tarred line. As this may give out and cause some trouble, by stopping the water space, I have not adopted it, and shall be pleased to have the experience of any seagoing engineer on this important matter. A groove round the shaft is formed, due to this action, and in some cases the shaft has broken inside the stern tube, breaking not only it, but tearing open the hull, resulting in the foundering of the vessel. Steel has been used for screw shafts, but has not been found so suitable, as it corrodes more rapidly in the presence of salt water and gun metal than iron, and unless protected by a solid liner for the most part of its length, a mechanical feat which has not yet been achieved in ordinary construction, as this liner would require to be 20 ft. long. I find it exceedingly difficult to get a liner of only 7 ft. long in one piece, and the majority of 6 ft. liners are fitted *in two pieces*. The joint of the two liners is rarely *watertight*, and many shafts have been destroyed by this method of fitting these liners.

I trust that engine builders will make a step further in the fitting of these liners on these shafts, as it is against the interest of the *shipowner* to keep ships in dry dock from such causes as defective liners, and I think it will be only a matter of time when the screw shaft will be completely protected from sea water, at least inside the stern tube; and when this is done, I would have no hesitation in using steel for screw shafts. Though an easier forging than a crank shaft, these shafts are often liable to flaws of a very serious character, owing to the contraction of the *mass* of metal forming the coupling; the outside cooling first tears the center open, and when there is not much metal to turn off the face of the coupling, it is sometimes undiscovered. Having observed several of these cavities, some only when the *last cut* was being taken off, I have considered it advisable to have holes bored in the end and center of each coupling, as far through as the thickness of the flange; when the shafts are of large size, this is sure to find these flaws out. Another flaw, which has in many cases proved serious when allowed to extend, is situated immediately abaft the gun metal liner, in front of the propeller.

This may be induced by corrosion, caused by the presence of sea water, gun metal, and iron, assisted by the rotation of the shaft. It may also be caused under heavy strain, owing to the over-finishing of the shaft at this part under the steam hammer.

The forgermen, in these days of competition and low prices, are instructed to so finish that there won't be much weight to turn off when completing the shaft in the lathe. This is effected by the use of half-round blocks under the hammer, at a lower temperature than the rest of the forging is done, along with the use of a little water flung on from time to time; and it is remarkable how near a forging is in truth when centered in the lathe, and how little there is to come off. The effect of this manipulation is to form a hard ring of close grain about one inch thick from the circumference of the shaft inward. The metal in this ring is much harder than that in the rest of the shaft, and takes all the strain the inner section gives; consequently,

when strain is brought on, either in heavy weather or should the propeller strike any object at sea or in the Suez canal, a fracture is caused at the circumference. This, assisted by slight corrosion, has in my experience led in the course of four months to a screw shaft being seriously crippled.

I show you a section of a screw shaft found to be flawed, and which I had broken under the falling weight of a steam hammer, when the decided difference of the granules near the circumference from that in the central part conveyed to me that it was weakened by treatment I have referred to. I think more material should be left on the forging, and the high finish with a little cold water should be discontinued. Doing away with the outer bearing in rudder post is an improvement, provided the bearing in the outer end of screw shaft in the stern tube is sufficiently large. It allows the rudder post to have its own work to do without bringing any strain on the screw shaft, and in the event of the vessel's grounding and striking under the rudder post, it does not throw any strain on the screw shaft. It also tends to reduce weight at this part, where all the weight is overhung from the stern of the vessel.

[1]

A paper read before the Institute of Marine Engineers, Stratford, 1889.

EXPERIMENTAL AID IN THE DESIGN OF HIGH SPEED STEAMSHIPS.

By D. P.

The achievement of one triumph after another in the matter of high speed steamships, and especially the confidence with which pledges of certain results are given and accepted long before actual trials are made, form one of the most convincing proofs of the important part which scientific methods play in modern shipbuilding. This is evident in the case of ships embodying novel or hitherto untried features, and more especially so in cases where shipbuilders, having no personal practical experience or data, achieve such results. This was notably illustrated in the case of the Fairfield Co. undertaking some five years ago to build and engine a huge craft of most phenomenal form and proportions, and to propel the vessel at a given speed under conditions which appeared highly impracticable to many engaged in the same profession. The contract was proceeded with, however, and the Czar of Russia's wonderful yacht *Livadia* was the result, which (however much she may have justified the professional strictures as to form and proportions) entirely answered the designer's anticipations as to speed. Equally remarkable and far more interesting instances are the Inman liners *City of Paris* and *City of New York*, in whose design there was sufficient novelty to warrant the degree of misgiving which undoubtedly existed regarding the Messrs. Thomson's ability to attain the speed required. In the case at least of the *City of Paris*, Messrs. Thomson's intrepidity has been triumphantly justified. An instance still more opposite to our present subject is found in the now renowned Channel steamers *Princess Henrietta* and *Princess Josephine*, built by Messrs. Denny, of Dumbarton, for the Belgian government. The speed stipulated for in this case was 20½ knots, and although in one or two previous Channel steamers, built by the Fairfield Co., a like speed had been achieved, still the guaranteeing of this speed by Messrs. Denny was remarkable, in so far as the firm had never produced, or had to do with, any craft faster than 15 or 16 knots. The attainment not only of the speed guaranteed, but of the better part of a knot in excess of that speed, was triumphant testimony to the skill and care brought to bear upon the undertaking. In this case, at least, the result was not one due to a previous course of "trial and error" with actual ships, but was distinctly due to superior practical skill, backed and enhanced by knowledge and use of specialized branches in the science of marine architecture. Messrs. Denny are the only firm of private shipbuilders possessing an experimental tank for recording the speed and resistance of ships by means of miniature reproductions of the actual vessels, and to this fact may safely be ascribed their confidence in guaranteeing, and their success in obtaining, a speed so remarkable in itself and so much in excess of anything they had previously had to do with. Confirmatory evidence of their success with the Belgian steamers is afforded by the fact that they have recently been instructed to build for service between Stranraer and Larne a paddle steamer guaranteed to steam 19 knots, and have had inquiries as to other high speed vessels.

In estimating the power required for vessels of unusual types or of abnormal speed, where empirical formulæ do not apply, and where data for previous ships are not available, the system of experimenting with models is the only trustworthy expedient. In the case of the Czar's extraordinary yacht, the *Livadia*, already referred to, it may be remembered that previous to the work of construction being proceeded with,

experiments were made with a small model of the vessel by the late Dr. Tideman, at the government tank at Amsterdam. On the strength of the data so obtained, coupled with the results of trials made with a miniature of the actual vessel on Loch Lomond, those responsible for her stipulated speed were satisfied that it could be attained. The actual results amply justified the reliance placed upon such experiments.

The design of many of her Majesty's ships has been altered after trials with their models. This was notably the case in connection with the design of the Medway class of river gunboats. The Admiralty constructors at first determined to make them 110 ft. long, by only 26 ft. in breadth. A doubt arising in their minds, the matter was referred to the late Mr. Froude, who had models made of various breadths, with which he experimented. The results satisfied the Admiralty officers that a substantial gain, rather than a loss, would follow from giving them much greater beam than had been proposed, and this was amply verified in the actual ships.

So long ago as the last decade of last century, an extended series of experiments with variously shaped bodies, ships as well as other shapes, were conducted by Colonel Beaufoy, in Greenland dock, London, under the auspices of a society instituted to improve naval architecture at that time. Robert Fulton, of America, David Napier, of Glasgow, and other pioneers of the steamship, are related to have carried out systematic model experiments, although of a rude kind in modern eyes, before entering on some of their ventures. About 1840 Mr. John Scott Russell carried on, on behalf of the British Association, of which he was at that time one of its most distinguished members, an elaborate series of investigations into the form of least resistance in vessels. For this purpose he leased the Virginia House and grounds, a former residence of Rodger Stewart, a famous Greenock shipowner of the early part of the century, the house being used as offices, while in the grounds an experimental tank was erected. In it tests were made of the speed and resistance of the various forms which Mr. Russell's ingenuity evolved—notably those based on the well-known stream line theory—as possible types of the steam fleets of the future. All the data derived from experiment was tabulated, or shown graphically in the form of diagrams, which, doubtless, proved of great interest to the *savants* of the British Association of that day. Mr. Russell returned to London in 1844, and the investigations were discontinued.

It will thus be seen that model experiments had been made by investigators long before the time of the late Dr. William Froude, of Torquay. It was not, however, until this gentleman took the subject of resistance of vessels in hand that designers were enabled to render the results from model trials accurately applicable to vessels of full size. This was principally due to his enunciation and verification by experiment of what is now known as the "law of comparison," or the law by which one is enabled to refer accurately the resistance of a model to one of larger size, or to that of a full sized vessel. In effect, the law is this—for vessels of the same proportional dimensions, or, as designers say, of the same lines, there are speeds appropriate to these vessels, which vary as the square roots of the ratio of their dimensions, and at these appropriate speeds the resistances will vary as the cubes of these dimensions. The fundament upon which the law is based has recently been shown to have found expression in the works of F. Reech, a distinguished French scientist who wrote early in the century. There are no valid grounds for supposing that the discovery of Reech was familiar to Froude; but even were this so, it is abundantly evident that, although never claimed by himself, there are the best of grounds for claiming the law of comparison, as now established, to be an independent discovery of Froude's.

Dr. Froude began his investigations with ships' models at the experimental tank at Torquay about 1872, carrying it on uninterruptedly until his death in 1879. Since his decease, the work of investigation has been carried on by his son, Mr. R. E. Froude, who ably assisted his father, and originated much of the existing apparatus. At the beginning of 1886, the whole experimental appliances and effects were removed from Torquay to Haslar, near Portsmouth, where a large tank and more commodious offices have been constructed, with a view to entering more extensively upon the work of experimental investigation. The dimensions of the old tank were 280 ft. in length, 36 ft. in width, and 10 ft. in depth. The new one is about 400 ft. long, 20 ft. wide, and 9 ft. deep. The new establishment is more commodious and better equipped than the old, and although the experiments are taken over a greater length, the operators are enabled to turn out results with as great dispatch as in the Torquay tank. The adjacency of the new tank to the dockyard at Portsmouth enables the Admiralty authorities to make fuller and more frequent use of it than formerly. Since the value of the work carried on for the British government has become appreciated, several experimental establishments of a similar character have been instituted in other countries. The Dutch government in 1874 formed one at Amsterdam which, up till his death in 1883, was under the superintendence of Dr. Tideman, whose labors in this direction were second only to those of the late Dr. Froude. In 1877 the French naval authorities established an experimental tank in the dockyard at Brest, and the Italian government have just completed one on an elaborate scale in the naval dockyard at Spezia. The Spezia tank, which is 500 ft. in length by about 22 ft. in

breadth, is fully equipped with all the special and highly ingenious instruments and appliances which the scientific skill of the late Dr. Froude brought into existence, and have been since his day improved upon by his son, Mr. R. E. Froude, and other experts.

Through the courtesy of our own Admiralty and of Messrs. Denny, of Dumbarton, the Italians have been permitted to avail themselves of the latest improvements which experience has suggested, and the construction of the special machinery and apparatus required has been executed by firms in this country having previous experience in this connection—Messrs. Kelso & Co., of Commerce Street, Glasgow; and Mr. Robert W. Munro, of London.

Having briefly traced the origin and development of the system of model experiment, it may now be of interest to describe the *modus operandi* of such experiments, and explain the way in which they are made applicable to actual ships. The models with which experiments are made in those establishments conducted on the lines instituted by Mr. Froude are made of paraffin wax, a material well adapted for the purpose, being easily worked, impervious to water, and yielding a fine smooth surface. Moreover, when done with, the models may be remelted for further use and all parings utilized. They are produced in the following manner: A mould is formed in clay by means of cross sections made somewhat larger than is actually required, this allowance being made to admit of the cutting and paring afterward required to bring the model to the correct point. Into this mould a core is placed, consisting of a light wooden framework covered with calico and coated with a thick solution of clay to make it impervious to the melted paraffin. This latter substance is run into the space between the core and the mould and allowed to cool. This space, forming the thickness of the model, is usually from $\frac{3}{4}$ in. for a model of 10 ft. long to $1\frac{1}{4}$ in. and $1\frac{1}{2}$ in. for one of 16 ft. and 18 ft. long. When cold, the model is floated out of the mould by water pressure and placed bottom upward on the bed of a shaping machine, an ingenious piece of mechanism devised by the late Dr. Froude, to aid in reducing the rough casting to the accurate form. The bed of this machine, which travels automatically while the machine is in operation, can be raised or lowered to any desired level by adjusting screws. A plan of water lines of the vessel to be modeled is placed on a tablet geared to the machine, the travel of which is a function of the travel of the bed containing the model. With a pointer, which is connected by a system of levers to the cutting tools, the operator traces out the water lines upon the plan as the machine and its bed are in motion, with the result that corresponding lines are cut upon the model. The cutting tools are swiftly revolving knives which work on vertical spindles moved in a lateral direction (brought near or removed from each other), according to the varying breadth of the water lines throughout the length of the model, as traced out by the operator's pointer. In this way a series of longitudinal incisions are made on the model at different levels corresponding to the water lines of the vessel. The model is now taken from the bed of the machine and the superfluous material or projection between the incisions is removed by means of a spokeshave or other sharp hand tool, and the whole surface brought to the correct form, and made fair and smooth.

To test accuracy of form, the weight of model is carefully taken, and the displacement at the intended trial draught accurately determined from the plan of lines. The difference between the weight of model and the displacement at the draught intended is then put into the bottom of the model in the form of small bags of shot, and by unique and very delicately constructed instruments for ascertaining the correct draught, the smallest error can at once be detected and allowed for. The models vary in size from about one-tenth to one-thirtieth of the size of the actual ship. A model of the largest size can be produced and its resistance determined at a number of speeds in about two days or so. The mode of procedure in arranging the model for the resistance experiment, after the model is afloat in the tank at the correct draught and trim, consists in attaching to it a skillfully devised dynamometric apparatus secured to a lightly constructed carriage. This carriage traverses a railway which extends the whole length of the tank about 15 in. or 18 in. above the water. The floating model is carefully guided in its passage through the water by a delicate device, keeping it from deviating either to the right or left, but at the same time allowing a free vertical and horizontal motion. The carriage with the model attached is propelled by means of an endless steel wire rope, passing at each end of the tank around a drum, driven by a small stationary engine, fitted with a very sensitive governor, capable of being so adjusted that any required speed may be given to the carriage and model. The resistance which the model encounters in its passage through the water is communicated to a spiral spring, and the extension this spring undergoes is a measure of the model's resistance. The amount of the extension is recorded on a revolving cylinder to a much enlarged scale through the medium of levers or bell cranks supported by steel knife edges resting on rocking pieces. On the same cylinder are registered "time" and "distance" diagrams, by means of which a correct measure of the speed is obtained. The time diagram is recorded by means of a clock attached to an electric circuit, making contact every half second, and actuating a pen which forms an indent in what would otherwise be a straight line on

the paper. The distance pen, by a similar arrangement, traces another line on the cylinder in which are indents corresponding to fixed distances of travel along the tank, the indents being caused by small projections which strike a trigger at the bottom of the carriage as it passes, and make electric contact. From these time and distance diagrams accurate account can be taken of the speed at which the model and its supporting carriage have been driven. Thus on the same cylinder is recorded graphically the speed and resistance of the model. The carriage may be driven at any assigned speed by adjusting the governor of the driving engine already alluded to, but the record of the speed by means of the time and distance diagrams is more definite. When the resistances of the model have been obtained at several speeds, varying in some cases from 50 to 1,000 feet per minute, the speeds are set off in suitable units along a base line, and for every speed at which resistance is measured, the resistance is set off to scale as an ordinate value at those speeds. A line passing through these spots forms the "curve of resistance," from which the resistance experienced by the model at the given trial speeds or any intermediate speed can be ascertained. The resistance being known, the power required to overcome resistance and drive the actual ship at any given speed is easily deduced by applying the rule before described as the law of comparison.—*The Steamship.*

THE SHIP IN THE NEW FRENCH BALLET OF THE "TEMPEST."

A new ballet, entitled the "Tempest," by Messrs. Barbier and Thomas, has recently been put upon the stage of the Opera at Paris with superb settings. One of the most important of the several tableaux exhibited is the last one of the third act, in which appears a vessel of unusual dimensions for the stage, and which leaves far behind it the celebrated ships of the "Corsaire" and "L'Africaine." This vessel, starting from the back of the stage, advances majestically, describes a wide circle, and stops in front of the prompter's box.

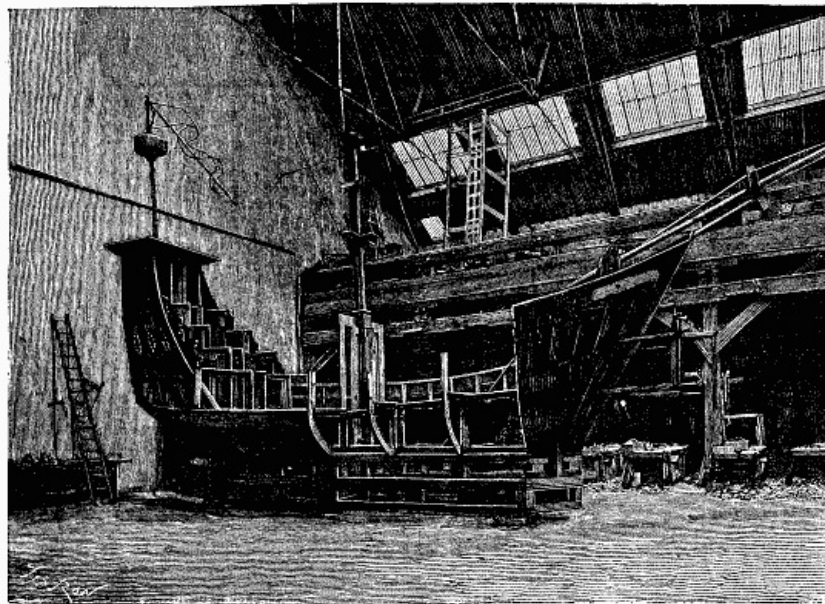
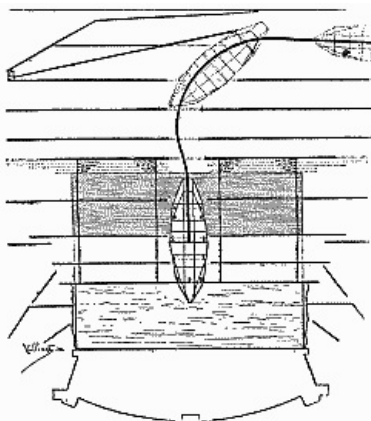

FIG. 1.—SHIP OF THE "TEMPEST," IN PROCESS OF CONSTRUCTION.



**FIG. 2.—SETTING OF THE
SCENERY BEFORE AND
AFTER THE APPEARANCE**

As the structure of this vessel and the mechanism by which it is moved are a little out of the ordinary, we shall give some details in regard to them. First, the sea is represented by four parallel strips of water, each formed of a vertical wooden frame entirely free in its movements (Fig. 2). The ship (Figs. 1, 2, 3, 4 and 5) is carried by wheels that roll over the floor of the stage. It is guided in its motion by two grooved bronze wheels and by a rail formed of a simple reversed T-iron which is fixed to the floor by bolts. In measure as it advances, the strips of water open in the center to allow it to pass, and, as the vessel itself is covered up to the water line with painted canvas imitating the sea, it has the appearance of cleaving the waves. As soon as it has passed, the three strips of water in the rear rise slightly. When the vessel reaches the first of the strips, the three other strips, at first juxtaposed against the

OF THE SHIP.

preceding, spread out and thus increase the extent of the sea, while the inclined plane of the preceding tableau advances in order to make place for the vessel. The shifting of this inclined place is effected by simply pulling upon the carpet that covers it, and which enters a groove in the floor in front of the prompter's box. At this moment, the entire stage seems to be in motion, and the effect is very striking.

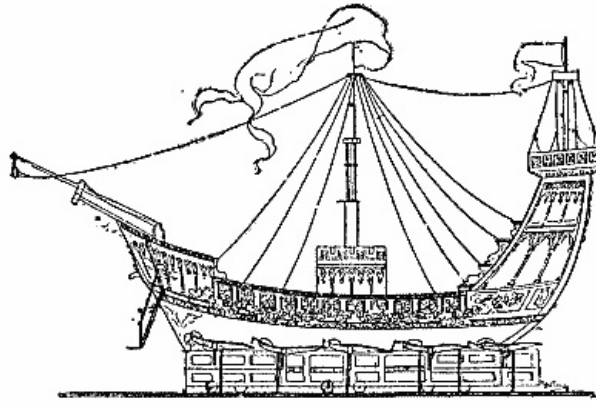

FIG. 3.—SHIP OF THE NEW BALLET, THE "TEMPEST."

We come now to the details of construction of the vessel. It is not here a question of a ship represented simply by means of frames and accessories, but of a true ship in its entirety, performing its evolutions over the whole stage. Now, a ship is not constructed at a theater as in reality. It does not suffice to have it all entire upon the stage, but it is necessary also to be able to dismount it after every representation, and that, too, in a large number of pieces that can be easily stored away. Thus, the vessel of the *Tempest*, which measures a dozen yards from stem to stern, and is capable of carrying fifty persons, comes apart in about 250 pieces of wood, without counting all the iron work, bolts, etc. Nevertheless, it can be mounted in less than two hours by ten skilled men.



FIG. 4.—THE SHIP WITH ITS OCCUPANTS.

The visible hull of the ship is placed upon a large and very strong wooden framework, formed of twenty-six trusses. In the center, there are two longitudinal trusses about three feet in height by twenty-five in length, upon which are assembled, perpendicularly, seven other trusses. In the interior there are six transverse pieces held by stirrup bolts, and at the extremity of each of these is fixed a thirteen-inch iron wheel. It is upon these twelve wheels that the entire structure rolls.

There are in addition the two bronze guide wheels that we have already spoken of. In the rear there are two large vertical trusses sixteen feet in height, which are joined by ties and descend to the bottom of the frame, to which they are bolted. These are worked out into steps and constitute the skeleton of the immense stern of the vessel. The skeleton of the prow is formed of a large vertical truss which is bolted to the front of the frame and is held within by a tie bar. On each side of this truss are placed the *parallels* (Figs. 1 and 3), which are formed of pieces of wood that are set into the frame below and are provided above with grooves for the passage of iron rods that support the foot rests by means of which the supernumeraries are lifted. As a whole, those rods constitute a jointed parallelogram, so that the foot rest always remains horizontal while describing a curve of five feet radius from the top of the frame to the deck of the vessel. They are actuated by a cable which winds around a small windlass fixed in the interior of the frame.

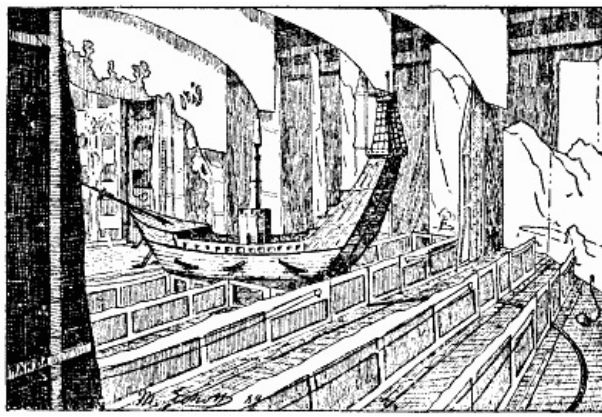

FIG. 5.—THE SHIP AS SEEN FROM THE STAGE.

The large mast consists of a vertical sheath 10 ft. high, which is set into the center of the frame, and in the interior of which slides a wooden spar that exceeds it by 5 ft. at first, and is capable of being drawn out as many more feet for the final apotheosis. This part of the mast carries three footboards and a platform for the reception of "supers." It is actuated by a windlass placed upon the frame.

To form the skeleton of the vessel there are mounted upon the frame a series of eight large vertical trusses parallel with each other and cross-braced by small trusses. The upper part of these supports the flooring of the deck, and their exterior portion affects the curve of a ship's sides. It is to these trusses that are attached the panels covered with painted canvas that represent the hull. These panels are nine in number on each side. Above are placed those that simulate the nettings and those that cover the prow or form its crest.

The turret that surrounds the large mast is formed of vertical trusses provided with panels of painted canvas and carrying a floor for the figurants to stand upon.

The bowsprit is in two parts, one sliding in the other. The front portion is at first pulled back, in order to hide the vessel entirely in the side scenes. It begins to make its appearance before the vessel itself gets under way. Light silken cordages connect the mast, the bowsprit, and the small mast at the stern.

On each side of the vessel, there are bolted to the frame that supports it five iron frames covered with canvas (Fig. 3), which reach the level of the water line, and upon which stand the "supers" representing the naiads that are supposed to draw the ship upon the beach. Finally at the bow there is fixed a frame which supports a danseuse representing the living prow of the vessel.

The vessel is drawn to the middle of the stage by a cable attached to its right side and passing around a windlass placed in the side scenes to the left (Fig. 2). It is at the same time pushed by machinists placed in the interior of the framework. The latter, as above stated, is entirely covered with painted canvas resembling water.

As the vessel, freighted with harmoniously grouped spirits, and with naiads, sea fairies, and graceful genii seeming to swim around it, sails in upon the stage, puts about, and advances as if carried along by the waves to the front of the stage, the effect is really beautiful, and does great credit to the machinists of the Opera.

We are indebted to *Le Genie Civil* and *Le Monde Illustré* for the description and engravings.

THE GIRARD HYDRAULIC RAILWAY.

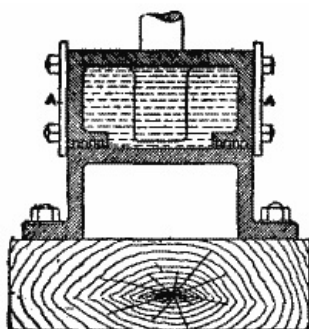

FIG. 1.

We give herewith some illustrations of this railway which has recently excited so much technical interest in Europe and America, and which threatens to revolutionize both the method and velocity of traveling, if only the initial expense of laying the line can be brought within moderate limits. A short line of railway has been laid in Paris, and we have there examined it, and traveled over the line more than once; so that we can testify to the smoothness and ease of the motion. Sir Edward Watkin examined the railway recently, and we understand that a line two miles long is to be laid in London, under his auspices. He seems to think it might be used for the Channel tunnel, being both smokeless and noiseless. It might also, if it could be

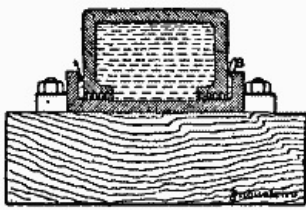

FIG. 2.

laid at a sufficiently low price, be useful for the underground railways in London, of one of which he is chairman. We are favorably impressed by the experiments we have witnessed; our misgivings are as to the cost. The railway is the invention of the well known hydraulic engineer, Monsieur Girard, who, as early as 1852, endeavored to replace the ordinary steam traction on railways by hydraulic propulsion, and in 1854 sought to diminish the resistance to the movement of the wagons by removing the wheels, and causing them to slide on broad rails. In order to test the invention, Mons. Girard demanded, and at the end of 1869 obtained, a concession for a short line from Paris to Argenteuil, starting in front of the Palais de l'Industrie, passing by Le Champ de Courses de Longchamps, and crossing the Seine at Suresnes. Unfortunately, the war of 1870-71 intervened, during which the works were destroyed and Mons. Girard was killed. After his death the invention was neglected for some years. A short time ago, however, one of his former colleagues, Mons. Barre, purchased the plans and drawings of Mons. Girard from his family, and having developed the invention, and taken out new patents, formed a company to work them. The invention may be divided into two parts, which are distinct, the first relating to the mode of supporting the carriages and the second to their propulsion. Each carriage is carried by four or six shoes, shown in Figs. 3, 4, and 5; and these shoes slide on a broad, flat rail, 8 in. or 10 in. wide. The rail and shoe are shown in section in Fig. 1. The rail is bolted to longitudinal wooden sleepers, and the shoe is held on the rail by four pieces of metal, A, two on each side, which project slightly below the top of the rail. The bottom of the shoe which is in contact with the rail is grooved or channeled, so as to hold the water and keep a film between each shoe and the rail. The carriage is supported by vertical rods, which fit one into each shoe, a hole being formed for that purpose; and the point of support being very low, and quite close to the rail, great stability is insured. It is proposed to make the rail of the form shown in Fig. 2 in future, as this will avoid the plates, A, and the flanges, B, will help to keep the water on the rail. Figs. 3, 4, and 5 show the shoe in detail. Fig. 3 gives a longitudinal section, Fig. 4 is a plan, and Fig. 5 is a plan of the shoe inverted, showing the grooves in its face. Fig. 3 shows the hollow shoe, into which water at a pressure of ten atmospheres is forced by a pipe from a tank on the tender. The water enters by the pipe, C, and fills the whole of the chamber, D. The water attempts to escape, and in doing so lifts the shoe slightly, thus filling the first groove of the chamber. The pressure again lifts the shoe, and the second chamber is filled; and so on, until ultimately the water escapes at the ends, E, and sides, F. Thus a film of water is kept between the shoe and the rail, and on this film the carriage is said to float. The water runs away into the channels, H H (Fig. 6), and is collected to be used over again. Fig. 3 also shows the means of supporting the carriage on the shoe by means of K, the point of support being very low. The system of grooves on the lower face of the shoe is shown in Fig. 5. So much for the means by which wheels are dispensed with, and the carriage enabled to slide along the line.

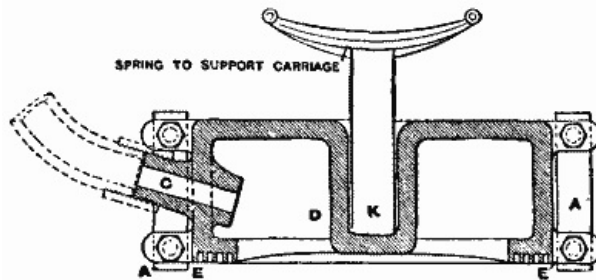

FIG. 3.

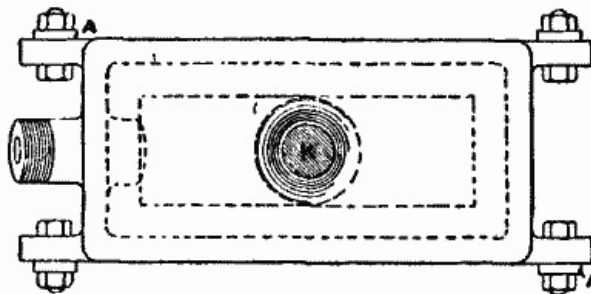

FIG. 4.

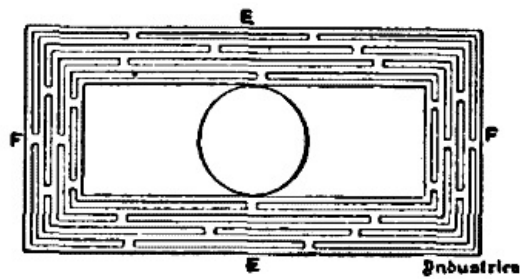

FIG. 5.

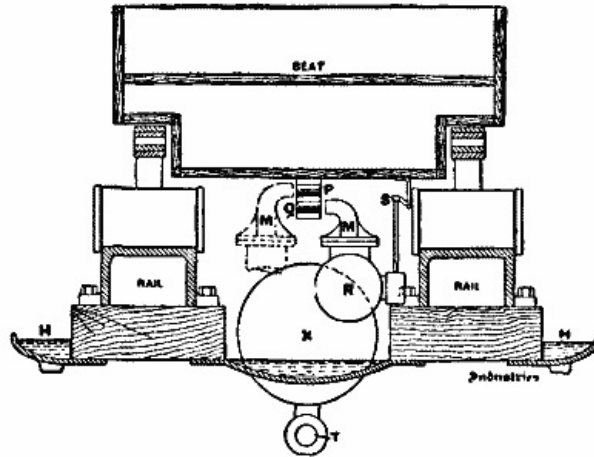

FIG. 6.

The next point is the method of propulsion. Figs. 7 and 8 give an elevation and plan of one of the experimental carriages. Along the under side of each of the carriages a straight turbine, L L, extends the whole length, and water at high pressure impinges on the blades of this turbine from a jet, M, and by this means the carriage is moved along. A parabolic guide, which can be moved in and out of gear by a lever, is placed under the tender, and this on passing strikes the tappet, S, and opens the valve which discharges the water from the jet, M, and this process is repeated every few yards along the whole line. The jets, M, must be placed at such a distance apart that at least one will be able to operate on the shortest train that can be used. In this turbine there are two sets of blades, one above the other, placed with their concave sides in opposite directions, so that one set is used for propelling in one direction and the other in the opposite direction. In Fig. 6 it is seen that the jet, M, for one direction is just high enough to act against the blades, Q, while the other jet is higher, and acts on the blades, P, for propulsion in the opposite direction. The valves, R, which are opened by the tappet, S, are of peculiar construction, and we hope soon to be able to give details of them. Reservoirs (Fig. 6) holding water at high pressure must be placed at intervals, and the pipe, T, carrying high pressure water must run the whole length of the line. Fig. 6 shows a cross section of the rail and carriage, and gives a good idea of the general arrangements. The absence of wheels and of greasing and lubricating arrangements will alone effect a very great saving, as we are informed that on the Lyons Railway, which is 800 kilometers long, the cost of oil and grease exceeds £400,000 per annum. As Sir Edward Watkin recently explained, all the great railway companies have long tried to find a substitute for wheels, and this railway appears to offer a solution of that problem. Mons. Barre thinks that a speed of 200 kilometers (or 120 miles) per hour may be easily and safely attained.

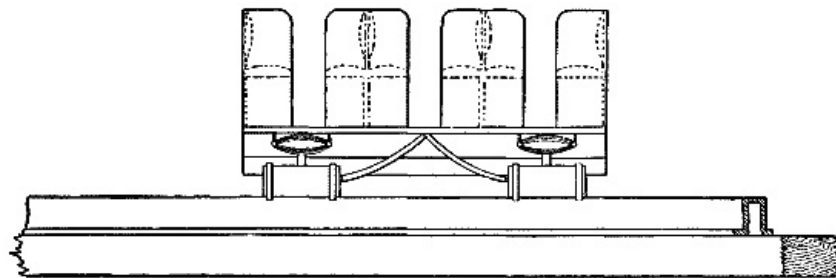

FIG. 7.

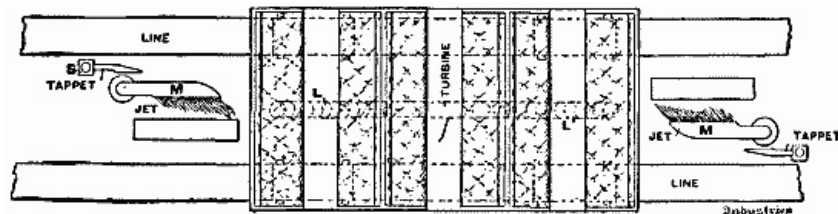

FIG. 8.

Of course, as there is no heavy locomotive, and as the traction does not depend upon pressure on the rail, the road may be made comparatively light. The force required to move a wagon along the road is very small, Mons. Barre stating, as the result of his experiments, that an effort amounting to less than half a kilogramme is sufficient to move one ton when suspended on a film of water with his improved shoes. It is recommended that the stations be placed at the summit of a double incline, so that on going up one side of the incline the motion of the train may be arrested, and on starting it may be assisted. No brakes are required, as the friction of the shoe against the rail, when the water under pressure is not being forced through, is found to be quite sufficient to bring the train to a standstill in a very short distance. The same water is run into troughs by the side of the line, and can be used over and over again indefinitely, and in the case of long journeys, the water required for the tender could be taken up while the train is running. The principal advantages claimed for the railway are: The absence of vibration and of side rolling motion; the pleasure of traveling is comparable to that of sleighing over a surface of ice, there is no noise, and what is important in town railways, no smoke; no dust is caused by the motion of the train during the journey. It is not easy for the carriages to be thrown from the rails, since any body getting on the rail is easily thrown off by the shoe, and will not be liable to get underneath, as is the case with wheels; the train can be stopped almost instantly, very smoothly, and without shock. Very high speed can be attained; with water at a pressure of 10 kilogrammes, a speed of 140 kilometers per hour can be attained; great facility in climbing up inclines and turning round the curves; as fixed engines are employed to obtain the pressure, there is great economy in the use of coal and construction of boilers, and there is a total absence of the expense of lubrication. It is, however, difficult to see how the railway is to work during a long and severe frost. We hope to give further illustrations at an early date of this remarkable invention.—*Industries*.

QUARTZ FIBERS.¹

In almost all investigations which the physicist carries out in the laboratory, he has to deal with and to measure with accuracy those subtile and to our senses inappreciable forces to which the so-called laws of nature give rise. Whether he is observing by an electrometer the behavior of electricity at rest or by a galvanometer the action of electricity in motion, whether in the tube of Crookes he is investigating the power of radiant matter, or with the famous experiment of Cavendish he is finding the mass of the earth—in these and in a host of other cases he is bound to measure with certainty and accuracy forces so small that in no ordinary way could their existence be detected, while disturbing causes which might seem to be of no particular consequence must be eliminated if his experiments are to have any value. It is not too much to say that the very existence of the physicist depends upon the power which he possesses of producing at will and by artificial means forces against which he balances those that he wishes to measure.

I had better perhaps at once indicate in a general way the magnitude of the forces with which we have to deal.

The weight of a single grain is not to our senses appreciable, while the weight of a ton is sufficient to crush the life out of any one in a moment. A ton is about 15,000,000 grains. It is quite possible to measure with unflinching accuracy forces which bear the same relation to the weight of a grain that a grain bears to a ton.

To show how the torsion of wires or threads is made use of in measuring forces, I have arranged what I can hardly dignify by the name of an experiment. It is simply a straw hung horizontally by a piece of wire. Resting on the straw is a fragment of sheet iron weighing ten grains. A magnet so weak that it cannot lift the iron yet is able to pull the straw round through an angle so great that the existence of the feeble attraction is evident to every one in the room.

Now it is clear that if, instead of a straw moving over the table simply, we had here an arm in a glass case and a mirror to read the motion of the arm, it would be easy to observe a movement a hundred or a thousand times less than that just produced, and

therefore to measure a force a hundred or a thousand times less than that exerted by this feeble magnet.

Again, if instead of wire as thick as an ordinary pin I had used the finest wire that can be obtained, it would have opposed the movement of the straw with a far less force. It is possible to obtain wire ten times finer than this stubborn material, but wire ten times finer is much more than ten times more easily twisted. It is ten thousand times more easily twisted. This is because the torsion varies as the fourth power of the diameter. So we say $10 \times 10 = 100$, $100 \times 100 = 10,000$. Therefore, with the finest wire, forces 10,000 times feebler still could be observed.

It is therefore evident how great is the advantage of reducing the size of a torsion wire. Even if it is only halved, the torsion is reduced sixteenfold. To give a better idea of the actual sizes of such wires and fibers as are in use, I shall show upon the screen a series of such photographs taken by Mr. Chapman, on each of which a scale of thousandths of an inch has been printed.

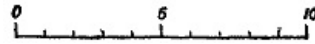

Scale of 1000ths of an inch for Figs. 1 to 7. The scale of Figs. 8 and 9 is much finer.

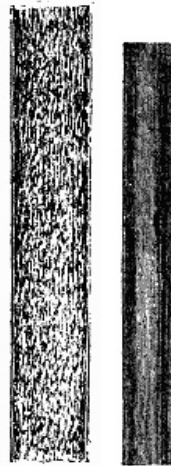

FIG. 1. FIG. 2.



FIG. 3.

The first photograph (Fig. 1) is an ordinary hair—a sufficiently familiar object, and one that is generally spoken of as if it were rather fine. Much finer than this is the specimen of copper wire now on the screen (Fig. 2), which I recently obtained from Messrs. Nalder Brothers. It is only a little over one-thousandth of an inch in diameter. Ordinary spun glass, a most beautiful material, is about one-thousandth of an inch in diameter, and this would appear to be an ideal torsion thread (Fig. 3). Owing to its fineness, its torsion would be extremely small, and the more so because glass is more easily deformed than metals. Owing to its very great strength, it can carry heavier loads than would be expected of it. I imagine many physicists must have turned to this material in their endeavor to find a really delicate torsion thread. I have so turned only to be disappointed. It has every good quality but one, and that is its imperfect elasticity. For instance, a mirror hung by a piece of spun glass is casting an image of a spot of light on the scale. If I turn the mirror, by means of a fork, twice to the right, and then turn it back again, the light does not come back to its old point of rest, but oscillates about a point on one side, which, however, is slowly changing, so that it is impossible to say what the point of rest really is. Further, if the glass is twisted one way first and then the other way, the point of rest moves in a manner which shows that it is not influenced by the last deflection alone: the glass remembers what was done to it previously. For this reason spun glass is quite unsuitable as a torsion thread; it is impossible to say what the twist is at any time, and therefore what is the force developed.

So great has the difficulty been in finding a fine torsion thread that the attempt has been given up, and in all the most exact instruments silk has been used. The natural cocoon fibers, as shown on the screen (Fig. 4), consist of two irregular lines gummed together, each about one two-thousandth of an inch in diameter. These fibers must be separated from one another and washed. Then each component will, according to the experiment of Gray, carry nearly 60 grains before breaking, and can be safely loaded with 15 grains. Silk is therefore very strong, carrying at the rate of from 10 to

20 tons to the square inch. It is further valuable in that its torsion is far less than that of a fiber of the same size of metal or even of glass, if such could be produced. The torsion of silk, though exceedingly small, is quite sufficient to upset the working of any delicate instrument, because it is never constant. At one time the fiber twists one way and another time in another, and the evil effect can only be mitigated by using large apparatus in which strong forces are developed. Any attempt that may be made to increase the delicacy of apparatus by reducing their dimensions is at once prevented by the relatively great importance of the vagaries of the silk suspension.

The result, then, is this. The smallness, the length of period, and therefore delicacy, of the instruments at the physicist's disposal have until lately been simply limited by the behavior of silk. A more perfect suspension means still more perfect instruments, and therefore advance in knowledge.

It was in this way that some improvements that I was making in an instrument for measuring radiant heat came to a deadlock about two years ago. I would not use silk, and I could not find anything else that would do. Spun glass, even, was far too coarse for my purpose, it was a thousand times too stiff.



FIG. 4.



FIG. 5.

There is a material invented by Wollaston long ago, which, however, I did not try because it is so easily broken. It is platinum wire which has been drawn in silver, and finally separated by the action of nitric acid. A specimen about the size of a single line of silk is now on the screen, showing the silver coating at one end (Fig. 5).

As nothing that I knew of could be obtained that would be of use to me, I was driven to the necessity of trying by experiment to find some new material. The result of these experiments was the development of a process of almost ridiculous simplicity which it may be of interest for me to show.

The apparatus consists of a small crossbow, and an arrow made of straw with a needle point. To the tail of the arrow is attached a fine rod of quartz which has been melted and drawn out in the oxyhydrogen jet. I have a piece of the same material in my hand, and now after melting their ends and joining them together, an operation which produces a beautiful and dazzling light, all I have to do is to liberate the string of the bow by pulling the trigger with one foot, and then if all is well a fiber will have been drawn by the arrow, the existence of which can be made evident by fastening to it a piece of stamp paper.

In this way threads can be produced of great length, of almost any degree of fineness, of extraordinary uniformity, and of enormous strength. I do not believe, if any experimentalist had been promised by a good fairy that he might have anything he desired, that he would have ventured to ask for any one thing with so many valuable properties as these fibers possess. I hope in the course of this evening to show that I am not exaggerating their merits.



FIG. 6. FIG. 7.

In the first place, let me say something about the degree of fineness to which they can be drawn. There is now projected upon the screen a quartz fiber one five-thousandth of an inch in diameter (Fig. 6). This is one which I had in constant use in an instrument loaded with about 30 grains. It has a section only one-sixth of that of a single line of silk, and it is just as strong. Not being organic, it is in no way affected by changes of moisture and temperature, and so it is free from the vagaries of silk which give so much trouble. The piece used in the instrument was about 16 inches long. Had it been necessary to employ spun glass, which hitherto was the finest torsion material, then, instead of 16 inches, I should have required a piece 1,000 feet long, and an instrument as high as the Eiffel tower to put it in.

There is no difficulty in obtaining pieces as fine as this yards long if required, or in spinning it very much finer. There is upon the screen a single line made by the small garden spider, and the size of this is perfectly evident (Fig. 7). You now see a quartz fiber far finer than this, or, rather, you see a diffraction phenomenon, for no true image is formed at all; but even this is a conspicuous object in comparison with the tapering ends, which it is absolutely impossible to trace in an microscope. The next two photographs, taken by Mr. Nelson, whose skill and resources are so famous, represent the extreme end of a tail of quartz, and, though

the scale is a great deal larger than that used in the other photographs, the end will be visible only to a few. Mr. Nelson has photographed here what it is absolutely impossible to see. What the size of these ends may be, I have no means of telling. Dr. Royston Piggott has estimated some of them at less than one-millionth of an inch, but, whatever they are, they supply for the first time objects of extreme smallness the form of which is certainly known, and, therefore, I cannot help looking upon them as more satisfactory tests for the microscope than diatoms and other things of the real shape of which we know nothing whatever.

Since figures as large as a million cannot be realized properly, it may be worth while to give an illustration of what is meant by a fiber one-millionth of an inch in diameter.

A piece of quartz an inch long and an inch in diameter would, if drawn out to this degree of fineness, be sufficient to go all the way round the world 658 times; or a grain of sand just visible—that is, one-hundredth of an inch long and one hundredth of an inch in diameter—would make one thousand miles of such thread. Further, the pressure inside such a thread due to a surface tension equal to that of water would be 60 atmospheres.

Going back to such threads as can be used in instruments, I have made use of fibers one ten-thousandth of an inch in diameter, and in these the torsion is 10,000 times less than that of spun glass.

As these fibers are made finer their strength increases in proportion to their size, and surpasses that of ordinary bar steel, reaching, to use the language of engineers, as high a figure as 80 tons to the inch. Fibers of ordinary size have a strength of 50 tons to the inch.

While it is evident that these fibers give us the means of producing an exceedingly small torsion, and one that is not affected by weather, it is not yet evident that they may not show the same fatigue that makes spun glass useless. I have, therefore, a duplicate apparatus with a quartz fiber, and you will see that the spot of light comes back to its true place on the screen after the mirror has been twisted round twice.

I shall now for a moment draw your attention to that peculiar property of melted quartz that makes threads such as I have been describing a possibility. A liquid cylinder, as Plateau has so beautifully shown, is an unstable form. It can no more exist than can a pencil stand on its point. It immediately breaks up into a series of spheres. This is well illustrated in that very ancient experiment of shooting threads of resin electrically. When the resin is hot, the liquid cylinders, which are projected in all directions, break up into spheres, as you see now upon the screen. As the resin cools, they begin to develop tails; and when it is cool enough, *i.e.*, sufficiently viscous, the tails thicken and the beads become less, and at last uniform threads are the result. The series of photographs show this well.



There is a far more perfect illustration which we have only to go into the garden to find. There we may see in abundance what is now upon the screen—the webs of those beautiful geometrical spiders. The radial threads are smooth like the one you saw a few minutes ago, but the threads that go round and round are beaded. The spider draws these webs slowly, and at the same time pours upon them a liquid, and still further to obtain the effect of launching a liquid cylinder in space he, or rather she, pulls it out like the string of a bow, and lets it go with a jerk. The liquid cylinder cannot exist, and the result is what you now see upon the screen (Fig. 8). A more perfect illustration of the regular breaking up of a liquid cylinder it would be impossible to find. The beads are, as Plateau showed they ought to be, alternately large and small, and their regularity is marvelous. Sometimes two still smaller beads are developed, as may be seen in the second photograph, thus completely agreeing with the results of Plateau's investigations.

FIG. 8. FIG. 9. I have heard it maintained that the spider goes round her web and places these beads there afterward. But since a web with about 360,000 beads is completed in an hour—that is at the rate of about 100 a second—this does not seem likely. That what I have said is true, is made more probable by the photograph of a beaded web that I have made myself by simply stroking a quartz fiber with a straw wetted with castor oil (Fig. 9); it is rather larger than a spider line; but I have made beaded threads, using a fine fiber, quite indistinguishable from a real spider web, and they have the further similarity that they are just as good for catching flies.

Now, going back to the melted quartz, it is evident that if it ever became perfectly liquid, it could not exist as a fiber for an instant. It is the extreme viscosity of quartz, at the heat even of an electric arc, that makes these fibers possible. The only difference between quartz in the oxyhydrogen jet and quartz in the arc is that in the

first you make threads and in the second are blown bubbles. I have in my hand some microscopic bubbles of quartz showing all the perfection of form and color that we are familiar with in the soap bubble.

An invaluable property of quartz is its power of insulating perfectly, even in an atmosphere saturated with water. The gold leaves now diverging were charged some time before the lecture, and hardly show any change, yet the insulator is a rod of quartz only three-quarters of an inch long, and the air is kept moist by a dish of water. The quartz may even be dipped in the water and replaced with the water upon it without any difference in the insulation being observed.

Not only can fibers be made of extreme fineness, but they are wonderfully uniform in diameter. So uniform are they that they perfectly stand an optical test so severe that irregularities invisible in any microscope would immediately be made apparent. Every one must have noticed when the sun is shining upon a border of flowers and shrubs how the lines which spiders use as railways to travel from place to place glisten with brilliant colors. These colors are only produced when the fibers are sufficiently fine. If you take one of these webs and examine it in the sunlight, you will find that the colors are variegated, and the effect, consequently, is one of great beauty.

A quartz fiber of about the same size shows colors in the same way, but the tint is perfectly uniform on the fiber. If the color of the fiber is examined with a prism, the spectrum is found to consist of alternate bright and dark bands. Upon the screen are photographs taken by Mr. Briscoe, a student in the laboratory at South Kensington, of the spectra of some of these fibers at different angles of incidence. It will be seen that coarse fibers have more bands than fine, and that the number increases with the angle of incidence of the light. There are peculiarities in the march of the bands as the angle increases which I cannot describe now. I may only say that they appear to move not uniformly, but in waves, presenting very much the appearance of a caterpillar walking.

So uniform are the quartz fibers that the spectrum from end to end consists of parallel bands. Occasionally a fiber is found which presents a slight irregularity here and there. A spider line is so irregular that these bands are hardly observable; but, as the photograph on the screen shows, it is possible to trace them running up and down the spectrum when you know what to look for.

To show that these longitudinal bands are due to the irregularities, I have drawn a taper piece of quartz by hand, in which the two edges make with one another an almost imperceptible angle, and the spectrum of this shows the gradual change of diameter by the very steep angle at which the bands run up the spectrum.

Into the theory of the development of these bands I am unable to enter; that is a subject on which your professor of natural philosophy is best able to speak. Perhaps I may venture to express the hope, as the experimental investigation of this subject is now rendered possible, that he may be induced to carry out a research for which he is so eminently fitted.

Though this is a subject which is altogether beyond me, I have been able to use the results in a practical way. When it is required to place into an instrument a fiber of any particular size, all that has to be done is to hold the frame of fibers toward a bright and distant light, and look at them through a low-angled prism. The banded spectra are then visible, and it is the work of a moment to pick out one with the number of bands that has been found to be given by a fiber of the desired size. A coarse fiber may have a dozen or more, while such fibers as I find most useful have only two dark bands. Much finer ones exist, showing the colors of the first order with one dark band; and fibers so fine as to correspond to the white or even the gray of Newton's scale are easily produced.

Passing now from the most scientific test of the uniformity of these fibers, I shall next refer to one more homely. It is simply this: The common garden spider, except when very young, cannot climb up one of the same size as the web on which she displays such activity. She is perfectly helpless, and slips down with a run. After vainly trying to make any headway, she finally puts her hands (or feet) into her mouth and then tries again, with no better success. I may mention that a male of the same species is able to run up one of these with the greatest ease, a feat which may perhaps save the lives of a few of these unprotected creatures when quartz fibers are more common.

It is possible to make any quantity of very fine quartz fiber without a bow and arrow at all, by simply drawing out a rod of quartz over and over again in a strong oxyhydrogen jet. Then, if a stand of any sort has been placed a few feet in front of the jet, it will be found covered with a maze of thread, of which the photograph on the screen represents a sample. This is hardly distinguishable from the web spun by this magnificent spider in corners of greenhouses and such places. By regulating the jet and the manipulation, anything from one of these stranded cables to a single ultra-

microscope line may be developed.

And now that I have explained that these fibers have such valuable properties, it will no doubt be expected that I should perform some feat with their aid which, up to the present time, has been considered impossible, and this I intend to do.

Of all experiments, the one which has most excited my admiration is the famous experiment of Cavendish, of which I have a full size model before you. The object of this experiment is to weigh the earth by comparing directly the force with which it attracts things with that due to large masses of lead. As is shown by the model, any attraction which these large balls exert on the small ones will tend to deflect this 6 ft. beam in one direction, and then if the balls are reversed in position, the deflection will be in the other direction. Now, when it is considered how enormously greater the earth is than these balls, it will be evident that the attraction due to them must be in comparison excessively small. To make this evident, the enormous apparatus you see had to be constructed, and then, using a fine torsion wire, a perfectly certain but small effect was produced. The experiment, however, could only be successfully carried out in cellars and underground places, because changes of temperature produced effects greater than those due to gravity.²

Now I have in a hole in the wall an instrument no bigger than a galvanometer, of which a model is on the table. The balls of the Cavendish apparatus, weighing several hundredweight each, are replaced by balls weighing $1\frac{3}{4}$ pounds only. The smaller balls of $1\frac{3}{4}$ pounds are replaced by little weights of 15 grains each. The 6 foot beam is replaced by one that will swing round freely in a tube three-quarters of an inch in diameter. The beam is, of course, suspended by a quartz fiber. With this microscopic apparatus, not only is the very feeble attraction observable, but I can actually obtain an effect eighteen times as great as that given by the apparatus of Cavendish, and what is more important, the accuracy of observation is enormously increased.

The light from a lamp passes through a telescope lens, and falls on the mirror of the instrument. It is reflected back to the table, and thence by a fixed mirror to the scale on the wall, where it comes to a focus. If the mirror on the table were plane, the whole movement of the light would be only about eight inches, but the mirror is convex, and this magnifies the motion nearly eight times. At the present moment the attracting weights are in one extreme position, and the line of light is quiet. I will now move them to the other position, and you will see the result—the light slowly begins to move, and slowly increases in movement. In forty seconds it will have acquired its highest velocity, and in forty more it will have stopped at 5 feet $8\frac{1}{2}$ inches from the starting point, after which it will slowly move back again, oscillating about its new position of rest.

It is not possible at this hour to enter into any calculations; I will only say that the motion you have seen is the effect of a force of less than one ten-millionth of the weight of a grain, and that with this apparatus I can detect a force two thousand times smaller still. There would be no difficulty even in showing the attraction between two No. 5 shot.

And now, in conclusion, I would only say that if there is anything that is good in the experiments to which I have this evening directed your attention, experiments conducted largely with sticks, and string, and straw and sealing wax, I may perhaps be pardoned if I express my conviction that in these days we are too apt to depart from the simple ways of our fathers, and instead of following them, to fall down and worship the brazen image which the instrument maker hath set up.

[1]

Lecture delivered at the Royal Institution, on Friday, June 14, by Mr. C. V. Boys, F.R.S.—*Nature*.

[2]

Dr. Lodge has been able, by an elaborate arrangement of screens, to make this attraction just evident to an audience.—C. V. B.

NATURE, COMPOSITION, AND TREATMENT OF ANIMAL AND VEGETABLE FABRICS.

The inseparable duties of studying the composition of the various animal and vegetable fabrics, as also their nature—when in contact with the various mineral, vegetable, animal, and gaseous bodies applied in the individual industries—should

not devolve upon the heads, chemists, or managers of firms alone. It is most important that every intelligent workman, whom we cannot expect to acquire a very extensive knowledge of chemistry and perfect acquaintance of the particular nature and component parts of fabrics, should, at least, be able to thwart the possibility of the majority of accidents brought about in regard to the quality and aspect of materials treated by them.

In the treatment of wool the first operations are of no mean importance, and the whole subsequent operations and final results, almost as a whole, depend on the manner in which the fleece washing had been effected. In presence of suintine, as also fatty matters, as well as the countless kinds of acids deposited on the wool through exudation from the body, etc., the various agents and materials cannot act and deposit as evenly as might be desired, and the complete obliteration of the former, therefore, becomes an absolute necessity.

For vegetable fabrics a great technical and practical knowledge is already requisite in their cultivation itself, and before any operations are necessary at all. One of the greatest points is the ripeness of the fibers. It is almost an impossibility to produce delicate colors on vegetable fabrics which were gathered inopportunely. Numerous experiments have been made on cotton containing smaller or larger quantities of unripe fibers, and after the necessary preceding operations, have been dyed in rose, purple, and blue colors, and the beauty of the shades invariably differed in proportion to the greater or lesser quantities of unripe fibers contained in the samples, and by a careless admixture of unripe and unseasoned fibers the most brilliant colors have been completely spoiled in the presence of the former. These deficiencies of unripe vegetable fibers are so serious that the utmost precautions should be taken, not only by planters to gather the fibers in a ripe state, but the natural aspect of ripe and unripe fibers and their respective differences should be known to the operators of the individual branches in the cotton industry themselves.

The newest vegetable fabrics, as *ma* (China grass), *pina*, *abaca*, or Manila hemp, *agave*, jute, and that obtained from the palm tree, must be tended with equal care to that of cotton. The *ma*, or China grass, is obtained from the *Boehmeria nivea*, as also from the less known *Boehmeria puya*. The fibers of this stalk, after preparing and bleaching, have the whiteness of snow and the brilliancy of silk. By a special process—the description of which we must for the present leave in abeyance—the China grass can be transformed into a material greatly resembling the finest quality of wool. The greatest advantage afforded in the application of China grass is, moreover, that the tissues produced with this fiber are much more easily washed than silks, and in this operation they lose none of their beauty or their quality.

The *abaca* is produced from the fibrous parts of the bark of the wild banana tree, found in the Philippines. Its botanical denomination is *Musa troglodytarum*. The *abaca* fiber is not spun or wrung, but is jointed end to end. The threads are wound and subsequently beaten for softening, and finally bleached by plunging in lime water for twenty-four hours, and dried in the sun.

The *pina* is a fiber obtained from the leaf of the anana tree (*Bromelias ananas*), and is prepared in the same way as the *abaca*, but extreme care must in this case be observed in culling the fibers, in order to sort in accordance with their degree of fineness.

The Arabs manufacture the stuff for their tents with a mixture of camel's hair and the fibrous flocks (kind of wadding) obtained from the stalks of the wafer palm (the *Chamærops humilis*).

The tissues used by the Arabs are coarse and colored, but the palm fibers—when freed from gluten, which makes them adhere more strongly—are susceptible to divide in a most astonishing manner.

The *Agave americana* is a coarse fiber, mostly used in France for the manufacture of Gobelin carpets and the production of ropes. Great efforts have been made to bleach it in a satisfactory manner, as is done with the *Phormium tenax*, but the former kind of fiber resists the ordinary treatment with lyes, etc., and an appropriate bleaching process has only been discovered quite recently.

Jute, which by many is confounded with *Phormium tenax*, or New Zealand lint, is a fiber which can be divided as finely as desired, and can be most beautifully bleached.

The jute or Indian *paat* is generally known as a fibrous and textile fabric, obtained chiefly from Calcutta, and is similar in nature to the *Corchorus capsularis*, an Oriental species, known in Oriental India by the name of *hatta jute* and *gheenatlapaat*. This fibrous plant has the property of dividing into the finest parallel fibers, which can be carded without difficulty, and may be said to have the excellent properties of linen, hemp, and cotton at once. When properly bleached, it has an aspect which is as beautiful as that of silk. A mixture of silk and jute can be easily

worked together, and can also be mixed with such vegetable fibers as cotton and linen. An immense quantity of flannel and other stuffs are now manufactured and imitated with the different mixtures containing jute.

The *suun* is a fiber of a plant in the form of a cane (*Crotalaria juncea*), and the *paat* or *suncheepaat* is the thread of a species of spiral (*Corchorus olitarius*), sold under the name of jute tissues.

The cotton tissues lose about twenty-five per cent. of their weight in bleaching, five per cent. of the substances are dissolved through alkalies, and the other twenty per cent., which are not attacked directly through the alkalies, are removed through chlorine, acids, and the water itself. The linen and hemp tissues contain eighteen per cent. of substances which are soluble in alkalies, and they lose from twenty-seven to thirty per cent. of their weight when taken through the consecutive bleaching operations.

The substances do not alone include the substances contained in the fabric originally, but also such as are deposited in the preliminary treatment of the fabrics, as dirt from the hands of the operator, and gluten soluble in warm water; as also glue or gelatine, potash or soda, starch, albumen, and sugar, used by weavers, etc., and which are all soluble in water; further, such as greasy matters, calcareous soap, coppery soap, resinous or gummo-resinous matters, and the yellow and green coloring matters contained in textile fabrics, which are soluble in caustic soda; and finally, the earthy constituents which are soluble in acids.

The nature and composition of silk and wool is diametrically opposed to that of the former. The silk is more of a gummy nature, and is susceptible to decompose into a kind of gelatinous mass if specially treated.

The yellow coloring principle in silk was found only to be contained in a very small proportion, and consisting of several distinct bodies.

The wool contains, first, a fatty matter which is solid at an ordinary temperature, and perfectly liquid at 60° C.; secondly, a fatty matter which is liquid at 15° C.; thirdly, a fibrous substance which essentially constitutes the wool in the strict sense of the word.

The wool at least contains three important principles, as it will be known that the fibrous substance disengages sulphur and hydro-sulphuric acid without losing its peculiar properties; and it, therefore, appears probable that the sulphur entered as an element in the composition of a body which is perfectly distinct from the fibrous substance aforementioned.

In treating wool with nitric acid, and taking all possible precautions to determine as accurately as possible the quantity of sulphuric acid produced by the contents of sulphur in the wool by the reaction with chloride of barium, it will be found to contain from 1.53 to 1.87 per cent. of sulphur.—*Wool and Textile Fabrics*.

THE PRODUCTION OF AMMONIA FROM COAL.¹

By LUDWIG MOND.

As exemplifying to a certain extent the application of methodical research to an industrial problem, I propose to bring before you to-day an account of the work I have been engaged in for many years in relation to the procuring of new and abundant supplies of ammonia, and to investigations connected therewith.

Through the classic researches of Lawes and Gilbert, who proved, in opposition to no less an authority than Liebig, that ammonia is a most valuable manure which enables us not only to maintain, but to multiply, the yield of our fields, and thus to feed on the same area a much larger number of inhabitants, the immense importance of an abundant supply of ammonia, more particularly for the Old World, with its teeming population and worn-out soil, has been apparent to every one.

For many years Europe has paid to South America millions upon millions of pounds for ammonia in the shape of guano, and more recently, since the supply of guano practically ceased, for nitrate of soda, which effectually serves the same purpose as ammonia. During the past year South America exported 750,000 tons of nitrate, of which 650,000 went to Europe, representing a value of not less than 6,500,000*l*.

The problem of saving this immense expenditure to Europe, of making ourselves independent of a country so far away for the supply of a material upon which the prosperity of our agriculture—our most important industry—depends, by supplying

this ammonia from sources at our own command, is certainly one of the most important which our science has to solve.

It is more than 100 years since Berthollet ascertained that ammonia consists of nitrogen and hydrogen, two elements which we have in great abundance at our command, and innumerable attempts have been made during this century to produce this valuable product by the direct combination of the elements, as well as by indirect means. It has been equally well known that we are in possession of three abundant sources of nitrogen:

- (1.) In the shape of matter of animal origin.
- (2.) In the shape of matter of vegetable origin.
- (3.) In the atmosphere, which contains no less than 79 per cent. of uncombined nitrogen.

In olden times ammonia was principally obtained from animal matter, originally in Egypt by the distillation of camel dung, later on from urine, and from the distillation of bones and horn. The quantity so obtained was very small and the products very expensive. The introduction of coal gas for illumination gave us a considerable and constantly increasing supply of ammonia as a by-product of the gas manufacture, and until recently all practical efforts to increase our supply of ammonia were directed toward collecting and utilizing in the best possible manner the ammonia so obtained. The immense extension of the coal gas industry all over the world has in this way put us into possession of a very considerable amount of sulphate of ammonia, amounting in Europe now to 140,000 tons per annum. In recent years this has been augmented by the ammonia obtained by the distillation of shale, by the introduction of closed ovens for the manufacture of coke, combined with apparatus for condensing the ammonia formed in this manufacture, and also by the condensation of the ammonia contained in the gases from blast furnaces working with coal. But all these new sources have so far added only about 40,000 tons of sulphate of ammonia to our supply, making a total of 180,000 tons per annum, of which about 120,000 are produced in the United Kingdom, while we still import 650,000 tons of nitrate of soda, equivalent to 500,000 tons of sulphate of ammonia, to make up our requirements.

Many processes have from time to time been proposed to obtain ammonia from other sources. The distillation of turf, which contains upward of 3 per cent. of nitrogen, has received much attention, and a large number of inventors have endeavored to produce ammonia from the nitrogen of the air; but none of these processes has to my knowledge been successful on a manufacturing scale.

My attention was called to this subject at an early part of my career. Already, as far back as 1861, I undertook experiments to utilize, for the production of ammonia, waste leather, a waste material of animal origin at once abundant and very rich in nitrogen, containing from 12 per cent. to 15 per cent. of this element. Distillation in iron retorts yielded about half the nitrogen of this material in the form of ammonia, the carbon remaining in the retorts containing still from 6 per cent. to 8 per cent. Distillation with a moderate quantity of hydrate of lime increased the yield of ammonia only by 1 per cent. to 1½ per cent. A rather better result was obtained by distilling the ground residual carbon with hydrate of lime, but this operation proceeded very slowly, and the total yield of ammonia still remained very far below the quantity theoretically obtainable, so that I came to the conclusion that it was more rational to utilize the leather, reduced to powder by mechanical means, by mixing it directly with other manures.

A few years later I became connected with a large animal charcoal works, in which sulphate of ammonia was obtained as a by-product. Here again I was met with the fact that the yield of ammonia by no means corresponded with the nitrogen in the raw material and that the charcoal remaining in the retorts contained still about half as much nitrogen as had been present in the bones used.

From this time forward my attention was for many years given exclusively to the soda manufacture, and it was only in 1879 that I again took up the question of ammonia. I then determined to submit the various processes which had been proposed for obtaining ammonia from the nitrogen of the air to a searching investigation, and engaged Mr. Joseph Hawliczek to carry out the experimental work.

These processes may be broadly divided into three classes:

- (1.) Processes which propose to combine nascent hydrogen with nitrogen at high temperatures or by electricity, with or without the presence of acid gases.
- (2.) Processes in which nitrides are first formed, from which

ammonia is obtained by the action of hydrogen or steam.

(3.) Processes in which cyanides are first formed and the ammonia obtained from these by the action of steam.

We began with an investigation of those processes in which a mixture of steam and nitrogen or of steam and air is made to act upon coke at a high temperature, sometimes in the presence of lime, baryta, or an alkali, sometimes in the presence of hydrochloric acid.

Very numerous patents have been taken out in this direction and there is no doubt that ammonia has been obtained by these processes by many inventors, but as I was aware that coke contains a considerable quantity of nitrogen, frequently as much as 1.5 per cent., which might be the source of the ammonia obtained, I determined to carry on the investigation in such a way as to make quite certain whether we obtained the ammonia from the coke or from the nitrogen of the atmosphere, or from both. For this purpose we made for every experiment carried on by a mixture of nitrogen or air with steam another experiment with steam alone, carefully excluding nitrogen from the apparatus. A very large number of experiments carried on at carefully determined temperatures, ranging from 500° to 1,200°C., and in which the directions given by the various inventors were most carefully observed, all led to the same result, viz., that the quantities of ammonia obtained were the same whether nitrogen was introduced into the apparatus with the steam or whether steam alone was used, thus proving conclusively that the ammonia obtained was derived from the nitrogen contained in the coke.

Further, on carefully determining the nitrogen in the coke used, it was found that the quantity of ammonia we had obtained in burning coke in a current of nitrogen and steam very nearly corresponded with the total nitrogen in the coke, so that we subsequently made our nitrogen determinations in the coke by simply burning it in a current of steam.

A process belonging to this class, proposed by Hugo Fleck, in which a mixture of carbonic oxide, steam, and nitrogen is made to pass over lime at a moderate red heat in order to obtain ammonia, was also carefully tried. It was claimed for this process that it produced nascent hydrogen at temperatures at which the ammonia is not dissociated, and for this reason succeeded where others had failed. We found that a considerable amount of hydrogen was obtained in this way at a temperature not exceeding 350°C., and that the reaction was nearly complete at 500°C.; but although we tried many experiments over a great range of temperatures, we never obtained a trace of ammonia by this process.

Among experiments with processes of the second class, based upon the formation of nitrides and their subsequent decomposition, the nitrides of boron and titanium had received most attention from inventors. The nitride of boron, which is obtained by treating boracic acid with carbon in the presence of nitrogen, when acted upon by steam, forms boracic acid again and yields the whole of its nitrogen in the form of ammonia, but the high temperature at which the first reaction takes place, and the volatility of boracic acid in a current of steam, make it impossible to utilize this reaction industrially.

There seemed to be a better chance for a process patented by M. Tessier du Mothay, who proposed to bring a mixture of nitrogen and hydrogen into contact with titanium nitride and thus to form ammonia continuously. Titanium is the only element of which we know at present several combinations with nitrogen, and the higher of these does, on being acted upon by a current of hydrogen at an elevated temperature, produce ammonia and a lower nitride of titanium; but this lower nitride does not absorb nitrogen under any of the conditions under which we tried it, which explains the fact that if we passed a current of hydrogen and nitrogen over the higher nitride, we at first obtained a quantity of ammonia corresponding to the quantity which the nitride would give with hydrogen alone, but that the formation of ammonia then ceased completely.

Thus far we had quite failed to get the nitrogen of the air into action.

With the third class of processes, however, based upon the formation in the first instance of cyanides, we found by our very first experiments that the nitrogen of the atmosphere can be easily led into combination. A few experiments showed that the cyanide of barium was much more readily formed than any other cyanide; so we gave our full attention from this time to the process for obtaining ammonia by means of cyanide of barium invented by MM. Margueritte and Sourdeval. This process consists in heating a mixture of carbonate of barium with carbon in the presence of nitrogen, and subsequently treating the cyanide of barium produced with steam, thus producing ammonia and regenerating the carbonate of barium. A great difficulty in this process is that the carbonate of barium fuses at high temperatures, and when fused attacks fireclay goods very powerfully.

We found that this can be overcome by mixing the carbonate of barium with a sufficient quantity of carbon and a small quantity of pitch, and that in this way balls can be made which will not fuse, so that they can be treated in a continuous apparatus in which the broken briquettes can be charged from the top, and after treatment can be withdrawn from the bottom.

We found that the formation of cyanides required a temperature of at least $1,200^{\circ}\text{C.}$, and proceeded most readily at $1,400^{\circ}\text{C.}$, temperatures which, although difficult to attain, are still quite within the range of practical working, and we found no difficulty in obtaining a product containing 30 per cent. of barium cyanide, corresponding to a conversion into cyanide of 40 per cent. of the barium present.

We found, however, that the cyanide when exposed to the atmosphere at a temperature above 300°C. is readily destroyed under reformation of carbonate of barium, so that it is absolutely necessary to cool it down to this temperature before exposing it to the atmosphere, a fact of great importance that had hitherto been overlooked.

The operation for producing ammonia and regenerating the carbonate of barium by acting upon the cyanide with steam offers no difficulty whatever, and if the temperature is not allowed to exceed 500°C. , the results are quantitative. The regenerated carbonate of barium acts actually better than the ground witherite used in the first instance, and if care is taken that no impurities are introduced by the pitch which is used to remake the briquettes and to replace the small amount of carbon consumed at each operation, I see no reason why it should not continue to act for a very long time.

The cyanide is not acted on by carbonic oxide, but carbonic acid destroys it at high temperatures, so that it is not possible to produce it by heating the briquettes directly in a flame free from oxygen, but containing carbonic acid. The process has, therefore, to be carried out in closed vessels, and I designed for this purpose the following apparatus:

Clay retorts of moderate dimensions and thin walls are placed vertically in a furnace, passing through the hearth as well as through the arch of the furnace. These are joined at the bottom to cast iron retorts of the same shape as the earthenware retort. Through a cast iron mouthpiece on the top of the retort the material was introduced, while in the cast iron retort below the material was cooled to the necessary temperature by radiation and by the cold nitrogen gas introduced into the bottom of it. The lower end of the cast iron retort was furnished with an arrangement for taking out from time to time small quantities of the material, while fresh material was in the same proportion fed in at the top. As a source of nitrogen I used the gases escaping from the carbonating towers of the ammonia-soda process. The formation of cyanide of barium from barium carbonate, carbon, and nitrogen absorbs a very large amount of heat—no less than 97,000 calories per equivalent of the cyanide formed—which heat has to be transmitted through the walls of the retort. I therefore considered it necessary to use retorts with very thin walls, but I did not succeed in obtaining retorts of this description which would resist the very high temperatures which the process requires, and for this reason I abandoned these experiments. I was at that time not acquainted with the excellent quality of clay retorts used in zinc works, with which I have since experimented for a different purpose. I have no doubt that with such retorts the production of cyanides by this process can be carried out without great difficulty.

I believe that the process will prove remunerative for the manufacture of cyanogen products, which, if produced more cheaply, may in the future play an important role in organic synthesis, in the extraction of noble metals, and possibly other chemical and metallurgical operations.

The process certainly also offers a solution of the problem of obtaining ammonia from the nitrogen of the atmosphere, but whether this can be done with satisfactory commercial results is a question I cannot at present answer, as I have not been able to secure the data for making the necessary calculations.

I am the more doubtful about this point, as in the course of our investigations I have found means to produce ammonia at small cost and in great abundance from the immense store of combined nitrogen which we possess in our coal fields.

Among the processes for obtaining ammonia from the nitrogen of the air which we investigated, was one apparently of great simplicity, patented by Messrs. Rickman and Thompson. These gentlemen state that by passing air and steam through a deep coal fire, the nitrogen so passed through is to a certain extent converted into ammonia. In investigating this statement we found that the process described certainly yields a considerable quantity of ammonia, but when we burned the same coal at a moderate temperature by means of steam alone in a tube heated from the outside, we obtained twice as much ammonia as we had done by burning it with a

mixture of air and steam, proving in this case, as in all others, the source of the ammonia to have been the nitrogen contained in the coal. The quantity of ammonia obtained was, however, so large that I determined to follow up this experience, and at once commenced experiments on a semi-manufacturing scale to ascertain whether they would lead to practical and economic results.

I came to the conclusion that burning coal by steam alone at a temperature at which the ammonia formed should not be dissociated, although it yielded more ammonia, would not lead to an economic process, because it would require apparatus heated from the outside, of great complication, bulk, and costliness, on account of the immense quantity of raw material to be treated for a small amount of ammonia obtainable.

On the other hand, if the coal could be burned in gas producers by a mixture of air and steam, the plant and working of it would be simple and inexpensive, the gas obtained could be utilized in the same way as ordinary producer gas, and would pay to a large extent for the coal used in the operation, so that although only one-half of the ammonia would be obtained, it seemed probable that the result would be economical.

I consequently constructed gas producers and absorbing plant of various designs and carried on experiments for a number of years. These experiments were superintended by Mr. G. H. Beckett, Dr. Carl Markel, and, during the last four years, by Dr. Adolf Staub, to whose zeal and energy I am much indebted for the success that has been achieved. The object of these experiments was to determine the most favorable conditions for the economic working of the process with respect to both the cost of manufacture as well as the first cost and simplicity of plant. The cost of manufacture depends mainly upon the yield of ammonia, as the expenses remain almost the same whether a large or a small amount of ammonia is obtained; the only other item of importance is the quantity of steam used in the process. We found the yield of ammonia to vary with the temperature at which the producer was working, and to be highest when the producer was worked as cool as was compatible with a good combustion of the fuel. The temperature again depended upon the amount of steam introduced into the producer, and of course decreased the more steam increased. We obtained the best practical results by introducing about two tons of steam for every ton of fuel consumed. We experimented upon numerous kinds of fuel, common slack and burgy of the Lancashire, Staffordshire, and Nottinghamshire districts. We found not much difference in the amount of nitrogen contained in these fuels, which varied between 1.2 and 1.6 per cent., nor did we find much difference in the ammonia obtained from these fuels if worked under similar conditions. Employing the quantity of steam just named we recovered about half the nitrogen in the form of ammonia, yielding on an average 0.8 per cent. of ammonia, equal to 32 kilos, of sulphate per ton of fuel. In order to obtain regular results we found it necessary to work with a great depth of fuel in the producers, so that slight irregularities in the working would not affect results. Open burning kinds of slack do of course work with the greater ease, but there is no difficulty in using a caking fuel, as the low temperature at which the producers work prevents clinkering and diminishes the tendency of such fuels to cake together.

The quantity of steam thus required to obtain a good yield of ammonia is rather considerable, and threatened to become a serious item of expense. Only one-third of this steam is decomposed, in its passage through the producer, and two-thirds remain mixed with the gases which leave the producer. My endeavors were consequently directed toward finding means to recover this steam, and to return it to the producers, and also to utilize the heat of the gases which leave the producers with a temperature of 450° to 500° C., for raising steam for the same purpose. The difficulties in the way of attaining this end and at the same time of recovering, in a simple manner, the small amount of ammonia contained in the immense volume of gas we have to deal with, were very great. We obtain from one ton of coal 160,000 cubic feet of dry gas at 0° C. and atmospheric pressure. The steam mixed with this gas as it leaves the producer adds another 80,000 cubic feet to this, and the large amount of latent heat in this quantity of steam makes the problem still more difficult. The application of cooling arrangements, such as have been successfully applied to blast furnace gases, in which there is no steam present, and which depend upon the cooling through the metallic sides of the apparatus, is here practically out of the question. After trying a number of different kinds of apparatus, I have succeeded in solving the problem in the following way:

The gases issuing from the producers are led through a rectangular chamber partly filled with water, which is thrown up in a fine spray by revolving beaters so as to fill the whole area of the chamber. This water, of course, becomes hot; a certain quantity of it evaporates, the spray produced washes all dust and soot out of the gases, and also condenses the fixed ammonia. The water thus becomes, to a certain degree, saturated with ammonia salts, and a certain portion of it is regularly removed from the chamber and distilled with lime to recover the ammonia.

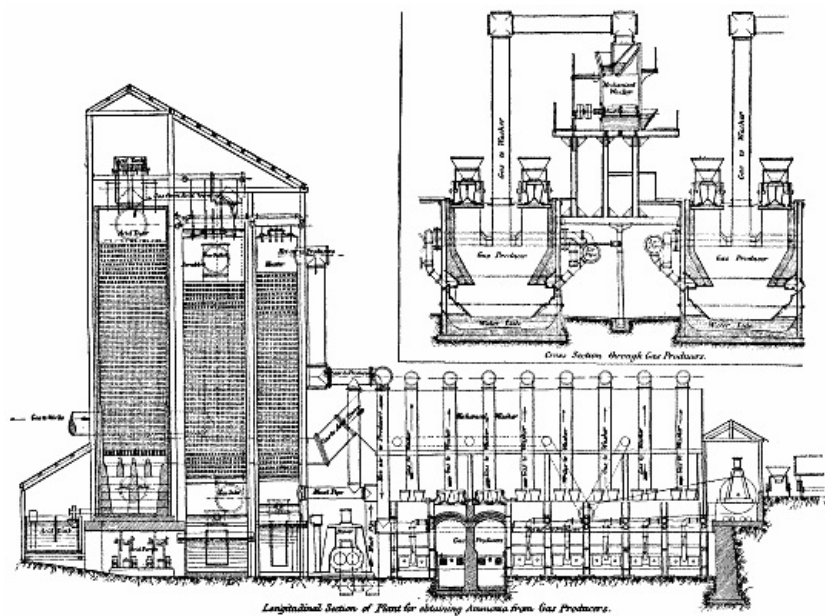

**Longitudinal Section of Plant for obtaining Ammonia from Gas Producers.
Cross Section through Gas Producers.**

This chamber is provided with water lutes, through which the tar condensed in it is from time to time removed. From this chamber the gases, which are now cooled down to about 100° C., and are loaded with a large amount of water vapor, are passed through a scrubber filled with perforated bricks, in which the ammonia contained in the gases is absorbed by sulphuric acid. In this scrubber a fairly concentrated solution of sulphate of ammonia containing 36 to 38 per cent. is used, to which a small quantity of sulphuric acid is added, so that the liquid leaving the scrubber contains only 2.5 per cent. of free acid. This is necessary, as a liquid containing more acid would act upon the tarry matter and produce a very dark-colored solution. The liquid running from the scrubber is passed through a separator in which the solution of sulphate of ammonia separates from the tar. The greater portion of the clear liquid is, after adding a fresh quantity of acid to it, pumped back through the scrubber. A certain portion of it is, after treatment with a small quantity of heavy tar oils, which take the tarry matter dissolved in it out, evaporated in conical lead-lined pans furnished with lead steam coils, and which are kept constantly filled by the addition of fresh liquor until the whole mass is thick. This is then run out on a strainer and yields, after draining and washing with a little water, a sulphate of ammonia of very fair quality, which finds a ready sale. The mother liquor, which contains all the free acid, is pumped back to the scrubber.

The gas on entering this scrubber contains only 0.13 volume per cent. of ammonia, and on leaving the scrubber it contains not more than one-tenth of this quantity. Its temperature has been reduced to 80° C., and is fully saturated with moisture, so that practically no condensation of water takes place in the scrubber. The gas is next passed through a second scrubber filled with perforated wood blocks. In this it meets with a current of cold water which condenses the steam, the water being thereby heated to about 78° C. In this scrubber the gas is cooled down to about 40°-50° C., and passes from it to the gas main leading to the various places where it is to be consumed. The hot water obtained in this second scrubber is passed through a vessel suitably constructed for separating the tar which is mixed with it, and is then pumped through a third scrubber, through which, in an opposite direction to the hot water, cold air is passed. This is forced by means of a Roots blower through the scrubber into the producer.

The air gets heated to about 76° C. and saturated with moisture at that temperature by its contact with the hot water, and the water leaves this third scrubber cold enough to be pumped back through the second scrubber. The same quantity of water is thus constantly used for condensing the water vapor in one scrubber and giving it up to the air in the other. In this way we recover and return to the producer fully two-thirds of the steam which has been originally introduced, so that we have to add to the air, which has thus been loaded with moisture, an additional quantity of steam equal to only one-third of the total quantity required before it enters the producer. This additional quantity of steam, which amounts to 0.6 ton of steam for every ton of fuel burnt, we obtain as exhaust steam from the engines driving the blowers and pumps required for working the plant.

The gas producers which I prefer to use are of rectangular shape, so that a number of them can be put into a row. They are six feet wide and 12 feet long inside. The air is introduced and the ashes removed at the two small sides of the producer which taper toward the middle and are closed at the bottom by a water lute of sufficient depth for the pressure under which the air is forced in, equal to about 4 inches of

water. The ashes are taken out from underneath the water, the producers having no grate or fire bars at all. The air enters just above the level of the water through a pipe connected with the blower. These small sides of the producer rest upon cast iron plates lined to a certain height with brickwork, and this brickwork is carried by horizontal cast iron plates above the air entrance. In this way a chamber is formed of triangular shape, one side of which is closed by the ashes, and thus the air is distributed over the whole width of the producer.

The gas is taken out in the middle of the top of the producer by an iron pipe, and fuel charged in by hoppers on both sides of this pipe. Between the pipe and the hoppers two hanging arches are put into the producers a certain distance down, and the fuel is kept above the bottom level of these hanging arches. This compels the products of distillation, produced when fresh fuel is charged in, to pass through the incandescent fuel between the two hanging arches, whereby the tarry products are to a considerable extent converted into permanent gas, and the coal dust arising from the charging is kept back in the producer.

The details of construction of this plant will be easily understood by reference to the diagrams before you.

The fuel we use is a common kind of slack, and contains, on an average, 33.5 per cent. of volatile matter, including water, and 11.5 per cent. of ashes, leaving 55 per cent. of non-volatile carbon.

The cinders which we take out of the producer contain, on an average, 33 per cent. of carbon. Of this we recover about one-half by riddling or picking, which we return to the producer. The amount of unburnt carbon lost in the cinders is thus not more than 3 per cent. to 4 per cent. on the weight of fuel used.

The gas we obtain contains, in a dry state, on an average, 15 per cent. of carbonic acid, 10 per cent. of carbonic oxide, 23 per cent. of hydrogen, 3 per cent. of hydrocarbons, and 49 per cent. of nitrogen.

The caloric value of this gas is very nearly equal to 73 per cent. of the caloric value of the fuel used, but in using this gas for heating purposes, such as raising steam or making salt, we utilize the heat it can give very much better than in burning fuel, as we can completely burn it with almost the theoretical quantity of air, so that the products of combustion resulting do not contain more than 1 to 2 per cent. of free oxygen. Consequently the heat escaping into the chimney is very much less than when fuel is burnt direct, and we arrive at evaporating, by means of the gas, 85 per cent. of the water that we would evaporate by burning the fuel direct, in ordinary fireplaces.

We have, however, to use a certain quantity of steam in the producers and in evaporating the sulphate of ammonia liquors, which has to be deducted from the steam that can be raised by the gas in order to get at the quantity of available steam therefrom obtainable. The former amounts, as already stated, to 0.6 ton, the latter to 0.1 ton of steam per ton of fuel burnt, making a total of 0.7 ton. The gas obtained from one ton of fuel evaporates 5.8 tons of water in good steam boilers, working at a rate of evaporation of 50 to 55 tons per 24 hours under 90 lb. pressure. Deducting from this the 0.7 ton necessary for working the plant leaves an available amount of steam raised by the gas from one ton of fuel of 5.1 tons, equal to 75 per cent. of the steam that we can obtain from the same fuel by hand firing.

In addition to the gas, we obtain about 3 per cent. of tar from the fuel. This tar is very thick, and of little commercial value. It contains only 4 per cent. of oils volatile below 200° C., and 38 per cent. of oils of a higher boiling point, consisting mostly of creosote oils very similar to those obtained from blast furnaces; and only small quantities of anthracene and paraffin wax.

I have made no attempts to utilize this tar except as fuel. It evaporates nearly twice as much water as its weight of coal, and we have thus to add its evaporative efficiency to that of the gas given above, leading to a total of about 80 per cent. of the evaporative efficiency of the fuel used in the producers. The loss involved in gasifying the fuel to recover the ammonia therefrom amounts thus to 20 per cent. of the fuel used. This means that, where we have now to burn 100 tons of fuel, we shall have to burn 125 tons in the producers in order to obtain ammonia equal to about half the nitrogen contained therein. Our actual yield of ammonia on a large scale amounting on an average to 32 kilos., equal to 70.6 lb. per ton of fuel, 125 tons of fuel will turn out 4 tons of sulphate of ammonia. We thus consume 6.25 tons of fuel for every ton of sulphate obtained, or nearly the same quantity as is used in producing a ton of caustic soda by the Le Blanc process—a product not more than half the value of ammonium sulphate. At present prices in Northwich this fuel represents a value of 35s. If we add to this the extra cost of labor over and above the cost of burning fuel in ordinary fireplaces, the cost of sulphuric acid, bags, etc., we come to a total of 4*l.* 10*s.* to 5*l.* per ton of sulphate of ammonia, which at the present

selling price of this article, say 12*l.* per ton, leaves, after a liberal allowance for wear and tear of plant, an ample margin of profit. With a rise in the price of fuel, this margin, however, rapidly decreases, and the working of the process will, of course, be much more expensive on a small scale, as will also be the cost of the plant, which under all circumstances is very considerable. The great advantages incidental to this process over and above the profit arising from the manufacture of sulphate of ammonia, viz., the absolute impossibility of producing smoke and the great regularity of the heating resulting from the use of gas, are, therefore, as far as I can see for the present, only available for large consumers of cheap fuel.

We have tried many experiments to produce hydrochloric acid in the producers, with the hope of thereby increasing the yield of ammonia, as it is well known that ammonium chloride vapor, although it consists of a mixture of ammonia gas and hydrochloric acid gas, is not at all dissociated at temperatures at which the dissociation of ammonia alone has already taken place to a considerable extent.

I had also hoped that I might in this way produce the acid necessary to combine with the ammonia at very small cost. For this purpose we moistened the fuel used with concentrated brine, and also with the waste liquors from the ammonia soda manufacture, consisting mainly of chloride of calcium; and we also introduced with the fuel balls made by mixing very concentrated chloride of calcium solution with clay, which allowed us to produce a larger quantity of hydrochloric acid in the producer than by the other methods.

We did in this way succeed in producing hydrochloric acid sometimes less and sometimes more than was necessary to combine with the ammonia, but we did not succeed in producing with regularity the exact amount of acid necessary to neutralize the ammonia. When the ammonia was in excess, we had therefore to use sulphuric acid as before to absorb this excess, and we were never certain that sometimes the hydrochloric acid might not be in excess, which would have necessitated to construct the whole plant so that it could have resisted the action of weak hydrochloric acid—a difficulty which I have not ventured to attack. The yield of ammonia was not in any case increased by the presence of the hydrochloric acid. This explains itself if we consider that there is only a very small amount of ammonia and hydrochloric acid diffused through a very large volume of other gases, so that the very peculiar protective action which the hydrochloric acid does exercise in retarding the dissociation of ammonia in ammonium chloride vapor, where an atom of ammonia is always in contact with an atom of hydrochloric acid, will be diminished almost to zero in such a dilute gas where the atoms of hydrochloric acid and ammonia will only rarely come into immediate contact with each other.

When we burnt coke by a mixture of air and steam in presence of a large excess of hydrochloric acid, the yield of ammonia certainly was thereby considerably increased, but such a large excess cannot be used on an industrial scale. I have therefore for the present to rest satisfied with obtaining only half the nitrogen contained in the fuel in the form of ammonia.

The enormous consumption of fuel in this country—amounting to no less than 150 million tons per annum—would at this rate yield as much as five million tons of sulphate of ammonia a year, so that if only one-tenth of this fuel would be treated by the process, England alone could supply the whole of the nitrogenous compounds, sulphate of ammonia, and nitrate of soda at present consumed by the Old World. As the process is especially profitable for large consumers of fuel situated in districts where fuel is cheap, it seems to me particularly suitable to be adopted in this country. It promises to give England the privilege of supplying the Old World with this all-important fertilizer, and while yielding a fair profit to the invested capital and finding employment for a considerable number of men, to make us, last not least, independent of the New World for our supply of so indispensable a commodity.

Before leaving my subject, I will, if you will allow me, give you in a few words a description of two other inventions which have been the outcome of this research. While looking one day at the beautiful, almost colorless, flame of the producer gas burning under one of our boilers, it occurred to me that a gas so rich in hydrogen might be turned to better use, and that it might be possible to convert it direct into electricity by means of a gas battery.

You all know that Lord Justice Grove showed, now fifty years ago, that two strips of platinum partly immersed in dilute sulphuric acid, one of which is in contact with hydrogen and the other with oxygen, produce electricity. I will not detain you with the many and varied forms of gas batteries which Dr. Carl Langer (to whom I intrusted this investigation) has made and tried during the last four years, in order to arrive at the construction of a gas battery which would give a practical result, but I will call your attention to the battery before me on the table, which is the last result of our extended labors in this direction, and which we hope will mark a great step in advance in the economic production of electricity.

The distinguishing feature of this battery is that the electrolyte is not employed as a mobile liquid, but in a quasi-solid form, and it is, therefore, named dry gas battery. It consists of a number of elements, which are formed of a porous diaphragm of a non-conducting material (in this instance plaster of Paris), which is impregnated with dilute sulphuric acid. Both sides of this diaphragm are covered with very fine platinum leaf perforated with very numerous small holes, and over this a thin film of platinum black. Both these coatings are in contact with frameworks of lead and antimony, insulated one from the other, which conduct the electricity to the poles of the battery.

A number of these elements are placed side by side, with non-conducting frames intervening, so as to form chambers through which the hydrogen gas is passed along one side of the element and air along the other.

This peculiar construction allows us to get a very large amount of duty from a very small amount of platinum. One of the batteries before you, consisting of seven elements, with a total effective surface of half a square meter, contains $2\frac{1}{2}$ grammes of platinum leaf and 7 grammes of platinum black, a total of $9\frac{1}{2}$ grammes of platinum, and produces a current of 2 amperes and 5 volts, or 10 watts, when the outer resistance is properly adjusted. This current is equal to nearly 50 per cent. of the total energy obtainable from the hydrogen absorbed in the battery.

In order to maintain a constant current, we have from time to time (say once an hour) to interchange the gases, so as to counteract the disturbing influence produced by the transport of the sulphuric acid gas from one side of the diaphragm to the other. This operation can easily be performed automatically by a commutator worked by a clock.

The water produced in the battery by the oxidation of the hydrogen is carried off by the inert gas mixed with the hydrogen, and by the air, of which we use a certain excess for this purpose. This is important, as if the platinum black becomes wet, it loses its absorbing power for the gases almost completely and stops the work of the battery. To avoid this was in fact the great difficulty in designing a powerful gas battery, and all previous constructions which employed the electrolyte as a mobile liquid failed in consequence.

The results obtained by our battery are practically the same whether pure oxygen and hydrogen or air and gases containing 25 per cent. of hydrogen are used; but we found that the latter gases must be practically free from carbonic oxide and hydrocarbons, which both interfere very much with the absorbing power of the platinum black.

We had thus to find a cheap method of eliminating these two gases from the producer gas, and converting them at the same time into their equivalent of hydrogen. The processes hitherto known for this purpose, viz., passing a mixture of such gases with steam over lime (which I mentioned some time ago) or over oxide of iron or manganese, require high temperatures, which render them expensive, and the latter do not effect the reaction to a sufficient extent for our purpose.

We have succeeded in attaining our object at a temperature below that at which the gases leave my producers, viz., at 350° C. to 450° C., by passing the producer gases, still containing a considerable excess of steam, over metallic nickel or cobalt. These metals have the extraordinary property of decomposing almost completely, even at the low temperature named, carbonic oxide into carbon and carbonic acid and hydrocarbons into carbon and hydrogen.

In order to carry the process out with small quantities of nickel and cobalt, we impregnate pumice stone or similar material with a salt of nickel or cobalt, and reduce this by means of hydrogen or producer gas. These pieces of pumice stone are filled into a retort or chamber and the hot gases passed through them. As the reaction produces heat, it is not necessary to heat the chambers or retorts from the outside when the necessary temperature has once been attained. This process has not yet been carried out on a large scale, but the laboratory experiments have been so satisfactory that we have no doubt as to its complete success. It will enable us to obtain gases containing 36 per cent. to 40 per cent. of hydrogen and practically free from carbonic oxide and hydrocarbons from producer gas at a very small cost, and thus to make the latter suitable for the production of electricity by our gas battery. We obtain, as stated before, 50 per cent. of the energy in the hydrogen absorbed in the battery in the form of electricity, while, if the same gas was consumed under steam boilers to make steam, which, as I have shown before, could in this way be raised cheaper than by burning fuel direct, and if this steam was turned into motive power by first-rate steam engines, and the motive power converted into electricity by a dynamo, the yield of electricity would in the most favorable case not exceed 8 per cent. of the energy in the gas. I hope that this kind of battery will one day enable us to perform chemical operations by electricity on the largest scale, and to press this potent power into the service of the chemical industries.

The statement is frequently made that "Necessity is the mother of invention." If this has been the case in the past, I think it is no longer so in our days, since science has made us acquainted with the correlation of forces, teaching us what amount of energy we utilize and how much we waste in our various methods for attaining certain objects, and indicating to us where and in what direction and how far improvement is possible; and since the increase in our knowledge of the properties of matter enables us to form an opinion beforehand as to the substances we have available for obtaining a desired result.

We can now foresee, in most cases, in what direction progress in technology will move, and in consequence the inventor is now frequently in advance of the wants of his time. He may even create new wants, to my mind a distinct step in the development of human culture. It can then no longer be stated that "Necessity is the mother of invention;" but I think it may truly be said that the steady, methodical investigation of natural phenomena is the father of industrial progress.

Sir Lowthian Bell, Bart., F.R.S., in moving a vote of thanks, said that the meeting had had the privilege of listening to a description of results obtained by a man of exceptional intelligence and learning, supplemented by that devotion of mind which qualified him to pursue his work with great energy and perseverance. The importance of the president's address could not possibly be overrated. At various periods different substances had been put forward as indications of the civilization of the people. He remembered hearing from Dr. Ure that he considered the consumption of sulphuric acid to be the most accurate measure of the civilization of the people.

In course of time sulphuric acid gave way to soap, the consumption of which was probably still regarded as the great exponent of civilization by such of his fellow citizens as had thereby made their name. From what he had heard that morning, however, he should be inclined to make soap yield to ammonia, as sulphuric acid had in its time succumbed to soap. For not only was ammonia of great importance to us as a manufacturing nation, but it almost appeared to be a condition of our existence. England had a large population concentrated on an area so small as to make it almost a matter of apprehension whether the surface could maintain the people upon it.

We were now importing almost as much food as we consumed, and were thus more and more dependent on the foreigner. Under certain conditions this would become a very serious matter, and thus any one who showed how to produce plenty of ammonia at a cheap rate was a benefactor to his country. Mr. Mond's process seemed to come nearer to success than any which had preceded it, and it needed no words from him to induce the meeting to accord a hearty vote of thanks to the president for his admirable paper.

Mr. J. C. Stevenson, M.P., in seconding the motion, said that no paper could be more interesting and valuable to the society than that delivered by the president. It opened out a future for the advancement of chemical industry which almost overcame one by the greatness of its possibilities. Mr. Mond had performed an invaluable service by investigating the various methods proposed for the manufacture of ammonia, and clearing the decks of those processes supposed by their inventors to be valuable, but proved by him to be delusive. It gave him hearty pleasure therefore to second the vote of thanks proposed by Sir Lowthian Bell.

The vote having been put and carried by acclamation, after a brief reply from the president:

The secretary read the report of the scrutators, which showed that 158 ballot papers had been sent in, 154 voting for the proposed list intact, and four substituting other names. The gentlemen nominated in the list issued by the Council were therefore declared elected.

[1]

A paper read at the annual general meeting of the Society of Chemical Industry, London, July 10, 1889.

In his brief report for the year ending May 1, 1889, the director of the Pasteur Institute, Paris, announces the treatment of 1,673 subjects, of whom 6 were seized with rabies during and 4 within a fortnight after the process. But 3 only succumbed after the treatment had been completely carried out, making 1 death in 554, or, including all cases, 1 in 128.

ALKALI MANUFACTORIES.

When the alkali, etc., Works Regulation Act was passed in 1881, it was supposed that the result would be that the atmosphere in the districts where such works are situated would be considerably improved, and, consequently, that vegetation would have a better chance in the struggle for existence, and the sanitary conditions of human dwellings would be advanced. In all these respects the act has been a success. But perhaps the most notable result is the effect which the act and those which have preceded it have had upon the manufactures which they control.

This was not anticipated by manufacturers, but now one of the principal of them (Mr. A. M. Chance) has stated that "Government inspection has not only led to material improvement in the general management of chemical works, but it has also been in reality a distinct benefit to, rather than a tax upon, the owners of such works."

This expression of opinion is substantiated by the chief inspector under the act, whose report for last year has recently been laid before the local government board.

There are 1,057 works in the United Kingdom which are visited by the inspectors, and in only two of these during 1888 did the neglect to carry out the inspectors' warnings become so flagrant as to call for legal interference; viz., in the case of Thomas Farmer & Co. (limited), Victoria Docks, E., who were fined 20*l.* and costs for failing to use the "best practicable means" for preventing the escape of acid gas from manure plant; and in the case of Joseph Fison & Co., Bramford, who were fined 50*l.* and costs for excessive escape of acid gas from sulphuric acid plant. There were seven other cases, but these were simply for failure to register under the act.

It is very evident, therefore, that from a public point of view the act is splendidly successful, and from the practical or scientific side it is no less satisfactory.

Of the total number of chemical works (1,057) 866 are registered in England, 131 in Scotland, and 44 in Ireland—a decrease in the case of Scotland of 8, and in Ireland of 2 from the previous year, while England has increased by 1. This must not, however, be taken as a sign of diminished production, because there is a tendency for the larger works to increase in size and for the smaller ones to close their operations. The principal nuisances which the inspectors have to prevent are the escape of hydrochloric acid gas from alkali works and of sulphurous gas from vitriol and manure works.

The alkali act forbids the manufacturer to allow the escape of more than 5 per cent. of the hydrochloric acid which he produces, or that that acid must not exist to a greater extent than 0.2 grain in 1 cubic foot of air, steam, or chimney gas which accompanies. The inspectors' figures for last year show that the percentage of the acid which escaped amounted to only 1.96 of the total produced, which is equal to 0.089 grain per cubic foot, and much below the figures for previous years. The figures in regard to sulphurous gas are equally satisfactory. The act allows 4 grains of sulphuric anhydride (SO₃) per cubic foot to escape into the air, and last year's average was only 0.737 grain, or less than a fifth of the limit.

Of course it is now the aim of the Leblanc alkali manufacturers to reduce the escape of hydrochloric acid to the lowest possible amount, as their profits depend solely upon the sale of chlorine products, soda products being sold at a loss. In this connection it is interesting to note that the amount of common salt manufactured in the United Kingdom in 1888 was 2,039,867 tons, and of this nearly 600,000 tons were taken by Leblanc soda makers, and over 200,000 tons by the ammonia-soda makers. The figures are very largely in excess of previous years, and indicate a gratifying growth in trade.

The salt used in the Leblanc process yields the hydrochloric acid, and that in the ammonia-soda method none, so that we may put down the theoretical production of acid as 380,000 tons, 7,600 tons of which was allowed to escape.

What was a mere trace in the chimney gases amounts, therefore, to a good round figure at the end of a year, and if it were converted into bleaching powder it would be worth nearly 150,000*l.* These figures are, it should be understood, based on theory, but they serve to show to what importance a gas has now reached which twenty-five years ago was a perfect incubus to the manufacturers, and wrought desolation in the country sides miles and miles around the producing works. There has long been an expectation that the ammonia-soda makers would add the manufacture of bleaching powder to their process, but they appear to be as far as ever from that result, and meanwhile the Leblanc makers are honestly striving to utilize every atom of the valuable material which they handle. Hence the eagerness to recover the sulphur from tank waste by one or other of the few workable processes which have been proposed.

This waste contains from 11 to 15 per cent. of sulphur, and when it is stated that the total amount of tank waste produced yearly is about 750,000 tons, containing about 100,000 tons of sulphur, it will be seen how large is the reward held out to the successful manipulator. Moreover, the value of the sulphur that might possibly be saved is not the only prize held out to those who can successfully deal with the waste, for this material is not only thrown away as useless, but much expense is incurred in the throwing.

In Lancashire and in other inland districts land must be found on which to deposit it, and the act of depositing is costly, for unless it is beaten together so as to exclude the air, an intolerable nuisance arises from it. The cost of haulage and deposit on land varies, according to the district, from 1s. to 1s. 6d. a ton. In Widnes it is about 1s.

In the Newcastle district the practice is to carry this material out to sea at a cost of about 4d. a ton.

Mr. Chance's process for the recovery of sulphur from the waste signalizes the centenary of the Leblanc process; Parnell and Simpson are following in his wake, and lately Mr. F. Gossage, of Widnes, has been working on a process for the production of alkali, which enables him to save the sulphur of the sulphuric acid. In his process a mixture of 70 parts Leblanc salt cake (sulphate of soda) and 30 parts common salt is mixed with coal and heated in a furnace, and so reduced to sulphide of sodium. The resulting "ash" is then dissolved in water and exposed to the action of carbonic acid, when sulphureted hydrogen is given off, to be dealt with as in Mr. Chance's sulphur process, while bicarbonate of soda is formed and separates by precipitation from the solution of undecomposed common salt.

Ere long it is expected this new method will be in active operation in some Leblanc works, the plant of which will, in all probability, be utilized. It has these great advantages: The absence of lime, the recovery of the sulphur used in the first instance and the consequent absence of the objectionable tank waste. Thus a bright promise is held out that the days of alkali waste are numbered, and that the air in certain parts of Lancashire will be more balmy than it has been in the memory of the oldest inhabitant.—*Chemist and Druggist*.

THE FUELS OF THE FUTURE.

It is undeniable that in this country, at least, we are accustomed to regard coal as the chief, and, indeed, the only substance which falls to be considered under the name of fuel. In other countries, however, the case is different. Various materials, ranging from wood to oil, come within the category of material for the production of heat. The question of fuel, it may be remarked, has a social, an antiquarian, and a chemical interest. In the first place, the inquiry whether or not our supplies of coal will hold out for say the next hundred thousand years, or for a much more limited period only, has been very often discussed by sociologists and by geological authorities.

Again, it is clear that as man advances in the practice of civilized arts, his dependence upon fuel becomes of more and more intimate character. He not merely demands fire wherewith to cook his food, and to raise his own temperature or that of his dwelling, but requires fuel for the thousand and one manufacturing operations in which he is perpetually engaged. It is obvious that without fuel civilized life would practically come to an end. We cannot take the shortest journey by rail or steamboat without a tacit dependence upon a fuel supply; and the failure of this supply would therefore mean and imply the extinction of all the comforts and conveniences on which we are accustomed to rely as aids to easy living in these latter days. Again, socially regarded, man is the only animal that practices the fire-making habit. Even the highest apes, who will sit round the fire which a traveler has just left, and enjoy the heat, do not appear to have developed any sense or idea of keeping up the fire by casting fresh fuel upon it. It seems fairly certain, then, that we may define man as being a "fuel-employing animal," and in so doing be within the bounds of certitude. He may be, and often is, approached by other animals in respect of many of his arts and practices. Birds weave nest materials, ants make—and maul—slaves, beavers build dams, and other animals show the germs and beginnings of human contrivances for aiding the processes of life, but as yet no animal save man lights and maintains a fire. That the fire-making habit must have dawned very early in human history appears to be proved by the finding of ashes and other evidences of the presence of fire among the remains and traces of primitive man.

All we know, also, concerning the history of savage tribes teaches us that humanity is skillful, even in very rude stages of its progress, in the making of fire. The contrivances for obtaining fire are many and curious in savage life, while, once

attained, this art seems to have not only formed a constant accompaniment but probably also a determining cause in the evolution of civilization. Wood, the fat of animals, and even the oils expressed from plants, probably all became known to man as convenient sources of fuel in prehistoric times. From the incineration of wood to the use of peat and coal would prove an easy stage in the advance toward present day practices, and with the attainment of coal as a fuel the first great era in man's fire-making habits may be said to end.

Beyond the coal stage, however, lies the more or less distinctively modern one of the utilization of gas and oil for fuel. The existence of great natural centers, or underground stores, of gas and oil is probably no new fact. We read in the histories of classic chroniclers of the blazing gases which were wont to issue from the earth, and to inspire feelings of superstitious awe in the minds of beholders. Only within a few years, however, have geologists been able to tell us much or anything regarding these reservoirs of natural fuel which have become famous in America and in the Russian province of Baku.

For example, it is now known that three products—gas, oil, and salt or brine—lie within natural receptacles formed by the rock strata in the order of their weight. This law, as has well been said, forms the foundation of all successful boring experiments, and the search for natural fuel, therefore, becomes as easy and as reliable a duty as that for artesian water or for coal. The great oil fever of the West was attended at first, as Professor M'Gee tells us, with much waste of the product. Wells were sunk everywhere, and the oil overflowed the land, tainting the rivers, poisoning the air, and often driving out the prospectors from the field of discovery. In Baku accidents and catastrophes have, similarly, been of frequent occurrence. We read of petroleum flowing from the ground in jets 200 feet high, and as thick as a man's body; we learn how it swept away the huge cranes and other machinery, and how, as it flowed away from the orifices, its course was marked by the formation of rivers of oil many miles in length.

In America the pressure of rock gas has burst open stills weighing over a ton, and has rushed through huge iron tanks and split open the pipes wherewith it was sought to control its progress. The roar of this great stream of natural gas was heard for miles around as it escaped from the outlet, and when it was ignited the pillar of flame illumined the surrounding country over a radius extending in some cases to forty miles. It is clear that man having tapped the earth's stores of natural fuel, stood in danger of having unloosed a monster whose power he seemed unable to control. Yet, as the sequel will show, science has been able to tackle with success the problems of mastering the force and of utilizing the energy which are thus locked up within the crust of the globe.

As regards the chemistry of rock gas, we may remark in the first place that this natural product ranks usually as light carbureted hydrogen gas. In this respect it is not unlike the marsh gas with which everyone is familiar, which is found bubbling up from swamps and morasses, and which constitutes the "will o' the wisp" of romance. In rock gas, marsh gas itself is actually found in the proportion of about 93 per cent. The composition of marsh gas is very simple. It consists of the two elements carbon and hydrogen united in certain proportions, indicated chemically by the symbol CH_4 . We find, in fact, that rock gas possesses a close relationship, chemically speaking, with many familiar carbon compounds, and of these latter, petroleum itself, asphaltum, coal, jet, graphite or plumbago, and even the diamond itself—which is only crystallized carbon after all—are excellent examples.

The differences between these substances really consist in the degree of fixing of the carbon or solid portion of the product, as it were, which exists. Thus in coal and jet the carbon is of stable character, such as we might expect to result from the slow decomposition of vegetable matter, and the products of this action are not volatile or liable to be suddenly dissociated or broken up. On the other hand, when we deal with the *hydrocarbons* as they are called, in the shape of rock gas, naphtha, petroleum, tar, asphaltum, and similar substances, we see how the carbon has become subordinated to the hydrogen part of the compounds, with the result of rendering them more or less unstable in their character. As Professor M'Gee has shown us, there is in truth a graduated series leading us from the marsh gas and rock gas as the lightest members of this class of compounds onward through the semi-gaseous naphtha to the fluid petroleum, the semi-fluid tar, the solid asphaltum, and the rigid and brittle substance known as albertite, with other and allied products. Having said so much regarding the chemistry of the fuels of the future, we may now pass to consider their geological record. A somewhat curious distribution awaits the man of science in this latter respect. Most readers are aware that the geologists are accustomed to classify rocks, according to their relative age, into three great groups, known respectively as the primary, secondary, and tertiary periods. In the secondary period we do not appear to meet with the fuels of the future, but as far back as the Devonian or old Red Sandstone period, and in the still older Silurian rocks, stores of gas and petroleum abound. In the latest or tertiary period, again, we come upon

nearly all the forms of fuels we have already specified.

The meaning of this geological distribution of the fuels is entirely fortuitous. Dr. M'Gee tells us that as their formation depended on local conditions (such as plant growth), and as we have no means of judging why such local conditions occurred within any given area, so must we regard the existence of fuel products in particular regions as beyond explanation. Of one point, however, we are well assured, namely that the volume of the fuels of the future is developed in an inverse proportion to their geological age. The proportionate volume, as it has been expressed, diminishes progressively as the geological scale is descended. Again, the weight of the fuels varies directly with their age; for it is in the older formation of any series that we come upon the oils and tars and asphaltum, while the marsh gas exists in later and more recently formed deposits. Further geological research shows us that the American gas fields exist each as an inverted trough or dome, a conformation due, of course, to the bending and twisting of the rocks by the great underground heat forces of the world. The porous part of the dome may be sandstone or limestone, and above this portion lie shales, which are the opposite of porous in texture. The dome, further, contains gas above, naphtha in the middle, and petroleum below, while last of all comes water, which is usually very salt. In the Indiana field, however, we are told that the oils lie near the springing or foundation of the arch of the dome, and at its crown gas exists, and overlies brine.

A very important inquiry, in relation to the statement that upon the products whose composition and history have just been described the fuel supply of the future will depend, consists in the question of the extent and duration of these natural gas and oil reservoirs. If we are beginning to look forward to a time when our coal supply will have been worked out, it behooves us to ask whether or not the supply of natural gas and oil is practically illimitable. The geologist will be able to give the coming man some degree of comfort on this point, by informing him that there seems to be no limit to the formation of the fuel of the future.

Natural gas is being manufactured to-day by nature on a big scale. Wherever plant material has been entombed in the rock formations, and wherever its decomposition proceeds, as proceed it must, there natural gas is being made. So that with the prospect of coal becoming as rare as the dodo itself, the world, we are told by scientists, may still regard with complacency the failure of our ordinary carbon supply. The natural gases and oils of the world will provide the human race with combustible material for untold ages—such at least is the opinion of those who are best informed on the subject. For one thing, we are reminded that gas is found to be the most convenient and most economical of fuels. Rock gas is being utilized abroad even now in manufacturing processes. Dr. M'Gee says that even if the natural supply of rock gas were exhausted to-morrow, manufacturers of glass, certain grades of iron, and other products would substitute an artificial gas for the natural product rather than return to coal. He adds that "enormous waste would thereby be prevented, the gas by which the air of whole counties in coke-burning regions is contaminated would be utilized, and the carbon of the dense smoke clouds by which manufacturing cities are overshadowed would be turned to good account." So that, as regards the latter point, even Mr. Ruskin with his horror of the black smoke of to-day and of the disfigurement of sky and air might become a warm ally of the fuel of the future. The chemist in his laudation of rock gas and allied products is only re-echoing, when all is said and done, the modern eulogy pronounced on ordinary coal gas as a cooking and heating medium.

We are within the mark when we say that the past five years alone have witnessed a wonderful extension in the use of gas in the kitchen and elsewhere. It would be singular, indeed, if we should happen to be already anticipating the fuel of the future by such a practice. Whether or not this is the case, it is at least satisfactory for mankind to know that the mother earth will not fail him when he comes to demand a substitute for coal. I may be too early even to think of the day of extinction; but we may regard that evil day with complacency in face of the stores of fuel husbanded for us within the rock foundations of our planet.—*Glasgow Herald*.

PORTABLE ELECTRIC LIGHT.

The famous house of MM. Sautter, Lemonnier & Co. takes a conspicuous part in the Paris exhibition, and from the wide range of its specialties exhibits largely in three important branches of industry: mechanics, electricity, and the optics of lighthouses and projectors. In these three branches MM. Sautter, Lemonnier & Co. occupy a leading position in all parts of the world.

The invention of the aplanetic projector, due to Col. Mangin, was a clever means of overcoming difficulties, practically insurmountable, that were inseparable from the

construction of parabolic mirrors; this contributed chiefly to the success of MM. Sautter, Lemonnier & Co. in this direction. The firm has produced more than 1,500 of these apparatus, representing a value of nearly £500,000, for the French and other governments.

Besides the great projector, which forms the central and crowning object of the exhibit of MM. Sautter, Lemonnier & Co. in the machinery hall, the firm exhibits a projector 90 centimeters in diameter mounted on a crane traveling on wheels, in the pavilion of the War Department. The lamp used for this apparatus has a luminous value of 6,000 carcels, with a current of 100 amperes; the amplifying power of the mirror is 2,025, which gives an intensity of ten millions to twelve millions of carcels to the beam.

Projectors used for field work are mounted on a portable carriage, which also contains the electric generator and the motor driving it.

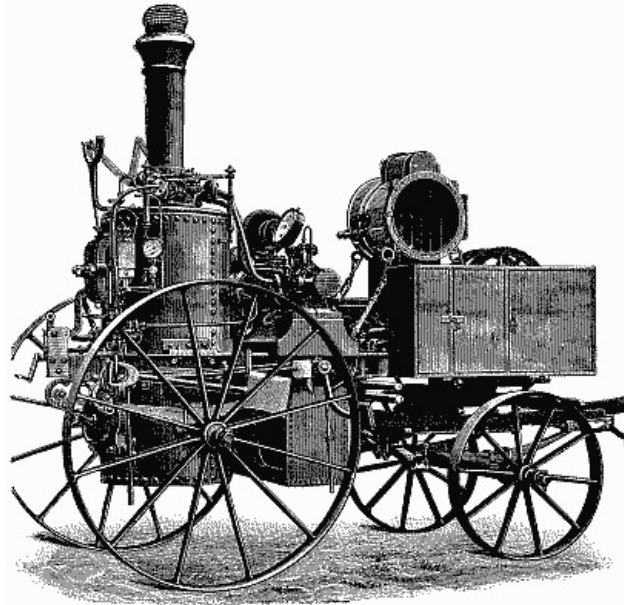

MILITARY PORTABLE ELECTRIC LIGHT AT THE PARIS EXHIBITION.

It consists of a tubular boiler (Dion, Bouton & Trepardoux system). This generator is easily taken to pieces, cleaned, and repaired, and steam can be raised to working pressure in 20 minutes. The mechanical and electrical part of the apparatus consists of a Parsons turbo-motor, of which MM. Sautter, Lemonnier & Co. possess the license in France for application to military and naval purposes. The speed of the motor is 9,000 revolutions per minute, and the dynamo is driven direct from it; at this speed it gives a current of 100 amperes with and from 55 to 70 volts; the intensity of the light is from 5,500 to 6,000 carcels. The carriage upon which the whole of this apparatus is mounted is carried on four wheels, made of wood with gun metal mountings. These are more easy to repair when in service than if they were wholly of iron. The weight of the carriage is three tons.—*Engineering*.

ELECTRIC MOTOR FOR ALTERNATING CURRENTS.

Prof. Galileo Ferraris, of Turin, who has carefully studied alternating currents and secondary transformers, has constructed a little motor based upon an entirely new principle, which is as follows: If we take two inductive fields developed by two bobbins, the axes of which cut each other at right angles, and a pole placed at the vertex of the angle, this pole will be subjected to the simultaneous action of the two bobbins, and the resultant of the magnetic actions will be represented in magnitude and direction by the diagonal of the parallelogram, two consecutive sides of which have for their length the intensity of the two fields, and for their direction the axes of the two bobbins.

If into each of these bobbins we send alternating currents having between one bobbin and the other a difference of phase of 90° , the extremity of the resultant will describe a circle having for its center the vertex of the right angle.

If, instead of a fixed pole, we use a metal cylinder movable on its axis, we shall obtain a continuous rotatory motion of this part, and the direction of the movement will change when we interchange the difference of phase in the exciting currents. This

rotatory movement is not due to the Foucault currents, for the metal cylinder may consist of plates of iron insulated from each other.

In order to realize the production of these fields, several means can be employed: The current is sent from an alternating current machine into the primary circuit of a transformer and thence into one of the bobbins, the other being supplied by means of the secondary current of the transformer. A resistance introduced into the circuit will produce the required difference of phase, and the equality of the intensities of the fields will be obtained by multiplying the number of turns of the secondary wire on the bobbin. Moreover, the two bobbins may be supplied by the secondary current of a transformer by producing the difference of phase, as in the first case.

In the motor constructed by Prof. Ferraris the armature consisted of a copper cylinder measuring 7 centimeters in diameter and 15 centimeters in length, movable on its axis. The inductors were formed of two groups of two bobbins. The bobbins which branched off from the primary circuit of a Gaulard transformer, and were connected in series, comprised 196 spirals with a resistance of 13 ohms; the bobbins comprising the secondary circuit were coupled in parallel, and had 504 spirals with 3.43 ohms resistance. In order to produce the difference of phase, a resistance of 17 ohms was introduced into the second circuit, when the dynamo produced a current of 9 amperes with 80 inversions per second. Under these conditions the available work measured on the axis of the motor was found for different speeds: Revolutions per minute: 262—400—546—650—722—770. Watts measured at the brake: 1.32—2.12—2.55—2.77—2.55—2.40. The maximum rendering corresponds to a speed of rotation of 650 revolutions, and Prof. Ferraris attributes the loss of work for higher speeds to the vibrations to which the machine is exposed. At present the apparatus is but a laboratory one.—*Bulletin International de l'Electricite.*

THE ELECTRIC AGE.

By CHARLES CARLETON COFFIN.

The application of electricity for our convenience and comfort is one of the marvels of the age. Never in the history of the world has there been so rapid a development of an occult science. Prior to 1819 very little was known in regard to magnetism and electricity. During that year Oersted discovered that an electric current would deflect a magnetic needle, thus showing that there was some relationship between electric and magnetic force. A few months later, Arago and Sir Humphry Davy, independently of each other, discovered that by coiling a wire around a piece of iron, and passing an electric current through it, the iron would possess for the time being all the properties of a magnet. In 1825 William Sturgeon, of London, bent a piece of wire in the form of the letter U, wound a second wire around it, and, upon connecting it with a galvanic battery, discovered that the first wire became magnetic, but lost its magnetic property the moment the battery was disconnected. The idea of a telegraphic signal came to him, but the electric impulse, through his rude apparatus, faded out at a distance of fifty feet. In 1830 Prof. Joseph Henry, of this country, constructed a line of wire, one and a half miles in length, and sent a current of electricity through it, ringing a bell at the farther end. The following year Professor Faraday discovered magnetic induction. This, in brief, is the genesis of magnetic electricity, which is the basis of all that has been accomplished in electrical science.

The first advance after these discoveries was in the development of the electric telegraph—the discovery in 1837, by the philosopher Steinhill, that the earth could serve as a conductor, thus requiring but one wire in the employment of an electric current. Simultaneously came Morse's invention of the mechanism for the telegraph in 1844, foreshadowed by Henry in the ringing of bells, thus transmitting intelligence by sound. Four years later, in 1848, Prof. M. G. Farmer, still living in Eliot, Me., attached an electro-magnet to clockwork for the striking of bells to give an alarm of fire. The same idea came to William F. Channing. The mechanism, constructed simply to illustrate the idea by Professor Farmer, was placed upon the roof of the Court House in Boston, and connected with the telegraph wire leading to New York, and an alarm rung by the operator in that city. The application of electricity for giving definite information to firemen was first made in Boston, and it was my privilege to give the first alarm on the afternoon of April 12, 1852.

At the close of the last century, Benjamin Thompson, born in Woburn, Mass., known to the world as Count Rumford, was in the workshop of the military arsenal of the King of Bavaria in Munich, superintending the boring of a cannon. The machinery was worked by two horses. He was surprised at the amount of heat which was generated, for when he threw the borings into a tumbler filled with cold water, it was set to boiling, greatly to the astonishment of the workmen. Whence came the heat? What was heat? The old philosopher said that it was an element. By experiment he

discovered that a horse working two hours and twenty minutes with the boring machinery would heat nineteen pounds of water to the boiling point. He traced the heat to the horse, but with all his acumen he did not go on with the induction to the hay and oats, to the earth, the sunshine and rain, and so get back to the sun. One hundred years ago there was no chemical science worthy of the name, no knowledge of the constitution of plants or the properties of light and heat. The old philosophers considered light and heat to be fluids, which passed out of substances when they were too full. Count Rumford showed that motion was convertible into heat, but did not trace the motion to its source, so far as we know, in the sun.

It is only forty-six years since Professor Joule first demonstrated the mutual relations of all the manifestations of nature's energy. Thirty-nine years only have passed since he announced the great law of the convertibility of force. He constructed a miniature churn which held one pound of water, and connected the revolving paddle of the churn with a wheel moved by a pound weight, wound up the weight, and set the paddle in motion. A thermometer detected the change of temperature and a graduated scale marked the distance traversed by the descending weight. Repeated experiments showed that a pound weight falling 772 feet would raise the temperature of water one degree, and that this was an unvarying law. This was transferring gravitation to heat, and the law held good when applied to electricity, magnetism, and chemical affinity, leading to the conclusion that they were severally manifestations of one universal power.—*Congregationalist*.

EARLY ELECTRIC LIGHTING.

The opening of the new station of the Electric Lighting Co., of Salem, Mass., was recently celebrated with appropriate festivities.

Among the letters of regret from those unable to attend the opening was the following from Prof. Moses G. Farmer:

"ELIOT, Me., Aug. 5, 1889.

"To the Salem Electric Lighting Company, Charles H. Price, President:

"GENTLEMEN: It would give me great pleasure to accept your kind invitation to be present at the opening of your new station in Salem on the 8th of this present August.

"It is now thirty years since the first dwelling house in Salem was lighted by electricity. That little obscure dwelling, 11 Pearl Street, formerly owned by 'Pa' Webb, had the honor to be illuminated by the effulgent electric beam during every evening of July, 1859, as some of your honored residents, perhaps, well remember. Mr. George D. Phippen can doubtless testify to one or more evenings; Mr. Wm. H. Mendell, of Boston, can also add his testimony; dozens of others could also do the same, had not some of them already passed to the 'great beyond,' among whom I well recollect the interest taken by the late and honored Henry L. Williams, Mr. J. G. Felt, and I do not know how many others. I well remember reading some of the very finest print standing with my back to the front wall and reading by the light of a 32 candle power lamp on the northernmost end of the mantel piece in the parlor; very possibly the hole in which the lamp was fastened remains to this day. In a little closet in the rear sleeping room was a switch which could be turned in one direction and give a beautiful glow light, while if turned in the other direction, it instantly gave as beautiful a dark. My then 12 year old daughter used to surprise and please her visitors by suddenly turning on and off the 'glim.' It is not well to despise the day of small things, for although the dynamo had not at that date put in an appearance, and though I used thirty-six Smee cells of six gallons capacity each, yet I demonstrated then and there that the incandescent electric light was a possibility, and although I innocently remarked to the late Samuel W. Bates, of Boston, who with his partner, Mr. Chauncey Smith, furnished so generously in the interest of science, not wholly without hope of return, the funds for the experiment, that it 'did not take much zinc,' and though Mr. Bates as naively replied, 'I notice that it takes some silver, though,' still it was then and there heralded as the coming grand illuminant for the dwelling. I am thankful to have lived to see my predictions partly fulfilled.

"During the early fifties I published a statement something like this: 'One pound of coal will furnish gas enough to maintain a candle light for fifteen hours. One pound of gas (the product of five pounds of coal) will, in a good fishtail gas burner, furnish one candle light for seventy-five hours. One pound of coal burned in a good furnace, under a good boiler, driving a good steam engine, turning a good magneto-electric machine, will give a candle light for one thousand hours. But if all the energy locked up in one pound of pure carbon could be wholly converted into light, it would maintain one candle light for more than one and a half years.'

"So, gentlemen, *nil desperandum*; there is still room for improvement. Let your motto be 'Excelsior.' Possibly you may have already extracted from one-fifteenth to one-twelfth of the energy stored in the pound of carbon, but hardly more. Go on, go on, and bring it so cheap as to reach the humblest dwelling when you shall celebrate the centennial of the opening of your new station.

"I do most sincerely regret that I cannot be with you in the flesh. I am, like Ixion of old, confined to a wheel (chair in my case), cannot walk, cannot even stand; hence, owing to the impairment of my understanding (???), I must wish you all the enjoyments of the evening, and gladly content myself that you have made so much possible.

"Very truly yours, MOSES G. FARMER."

THE MODERN THEORY OF LIGHT.¹

By Prof. OLIVER LODGE.

To persons occupied in other branches of learning, and not directly engaged in the study of physical science, some rumor must probably have traveled of the stir and activity manifest at the present time among the votaries of that department of knowledge.

It may serve a useful purpose if I try and explain to outsiders what this stir is mainly about, and why it exists. There is a proximate and there is an ultimate cause. The proximate cause is certain experiments exhibiting in a marked and easily recognizable way the already theoretically predicted connection between electricity and light. The ultimate cause is that we begin to feel inklings and foretastes of theories, wider than that of gravitation, more fundamental than any theories which have yet been advanced; theories which if successfully worked out will carry the banner of physical science far into the dark continent of metaphysics, and will illuminate with a clear philosophy much that is at present only dimly guessed. More explicitly, we begin to perceive chinks of insight into the natures of electricity, of ether, of elasticity, and even of matter itself. We begin to have a kinetic theory of the physical universe.

We are living, not in a Newtonian, but at the beginning of a perhaps still greater Thomsonian era. Greater, not because any one man is probably greater than Newton,² but because of the stupendousness of the problems now waiting to be solved. There are a dozen men of great magnitude, either now living or but recently deceased, to whom what we now know toward these generalizations is in some measure due, and the epoch of complete development may hardly be seen by those now alive. It is proverbially rash to attempt prediction, but it seems to me that it may well take a period of fifty years for these great strides to be fully accomplished. If it does, and if progress goes on at anything like its present rate, the aspect of physical science bequeathed to the latter half of the twentieth century will indeed excite admiration, and when the populace are sufficiently educated to appreciate it, will form a worthy theme for poetry, for oratorios, and for great works of art.

To attempt to give any idea of the drift of progress in all the directions which I have hastily mentioned, to attempt to explain the beginnings of the theories of elasticity and of matter, would take too long, and might only result in confusion. I will limit myself chiefly to giving some notion of what we have gained in knowledge concerning electricity, ether, and light. Even that is far too much. I find I must confine myself principally to light, and only treat of the others as incidental to that.

For now well nigh a century we have had a wave theory of light; and a wave theory of light is quite certainly true. It is directly demonstrable that light consists of waves of some kind or other, and that these waves travel at a certain well-known velocity, seven times the circumference of the earth per second, taking eight minutes on the journey from the sun to the earth. This propagation in time of an undulatory disturbance necessarily involves a medium. If waves setting out from the sun exist in space eight minutes before striking our eyes, there must necessarily be in space some medium in which they exist and which conveys them. Waves we cannot have unless they be waves in something.

No ordinary medium is competent to transmit waves at anything like the speed of light; hence the luminiferous medium must be a special kind of substance, and it is called the ether. The *luminiferous* ether it used to be called, because the conveyance of light was all it was then known to be capable of; but now that it is known to do a variety of other things also, the qualifying adjective may be dropped.

Wave motion in ether, light certainly is; but what does one mean by the term wave? The popular notion is, I suppose, of something heaving up and down, or, perhaps, of something breaking on the shore in which it is possible to bathe. But if you ask a mathematician what he means by a wave, he will probably reply that the simplest wave is

$$y = a \sin (p t - n x),$$

and he might possibly refuse to give any other answer.

And in refusing to give any other answer than this, or its equivalent in ordinary words, he is entirely justified; that is what is meant by the term wave, and nothing less general would be all-inclusive.

Translated into ordinary English the phrase signifies "a disturbance periodic both in space and time." Anything thus doubly periodic is a wave; and all waves, whether in air as sound waves, or in ether as light waves, or on the surface of water as ocean waves, are comprehended in the definition.

What properties are essential to a medium capable of transmitting wave motion? Roughly we may say two—*elasticity* and *inertia*. Elasticity in some form, or some equivalent of it, in order to be able to store up energy and effect recoil; inertia, in order to enable the disturbed substance to overshoot the mark and oscillate beyond its place of equilibrium to and fro. Any medium possessing these two properties can transmit waves, and unless a medium possesses these properties in some form or other, or some equivalent for them, it may be said with moderate security to be incompetent to transmit waves. But if we make this latter statement, one must be prepared to extend to the terms elasticity and inertia their very largest and broadest signification, so as to include any possible kind of restoring force and any possible kind of persistence of motion respectively.

These matters may be illustrated in many ways, but perhaps a simple loaded lath or spring in a vise will serve well enough. Pull aside one end, and its elasticity tends to make it recoil; let it go, and its inertia causes it to overshoot its normal position; both causes together cause it to swing to and fro till its energy is exhausted. A regular series of such springs at equal intervals in space, set going at regular intervals of time one after the other, gives you at once a wave motion and appearance which the most casual observer must recognize as such. A series of pendulums will do just as well. Any wave-transmitting medium must similarly possess some form of elasticity and of inertia.

But now proceed to ask what is this ether which in the case of light is thus vibrating? What corresponds to the elastic displacement and recoil of the spring or pendulum? What corresponds to the inertia whereby it overshoots its mark? Do we know these properties in the ether in any other way?

The answer, given first by Clerk Maxwell, and now reiterated and insisted on by experiments performed in every important laboratory in the world, is:

The elastic displacement corresponds to electrostatic charge (roughly speaking, to electricity).

The inertia corresponds to magnetism.

This is the basis of the modern electro-magnetic theory of light. Now let me illustrate electrically how this can be.

The old and familiar operation of charging a Leyden jar—the storing up of energy in a strained dielectric, any electrostatic charging whatever—is quite analogous to the drawing aside of our flexible spring. It is making use of the elasticity of the ether to produce a tendency to recoil. Letting go the spring is analogous to permitting a discharge of the jar—permitting the strained dielectric to recover itself, the electrostatic disturbance to subside.

In nearly all the experiments of electrostatics, ethereal elasticity is manifest.

Next consider inertia. How would one illustrate the fact that water, for instance, possesses inertia—the power of persisting in motion against obstacles—the power of possessing kinetic energy? The most direct way would be to take a stream of water and try suddenly to stop it. Open a water tap freely and then suddenly shut it. The impetus or momentum of the stopped water makes itself manifest by a violent shock to the pipe, with which everybody must be familiar. The momentum of water is utilized by engineers in the "water ram."

A precisely analogous experiment in electricity is what Faraday called "the extra current." Send a current through a coil of wire round a piece of iron, or take any other arrangement for developing powerful magnetism, and then suddenly stop the

current by breaking the circuit. A violent flash occurs if the stoppage is sudden enough, a flash which means the bursting of the insulating air partition by the accumulated electro-magnetic momentum.

Briefly, we may say that nearly all electro-magnetic experiments illustrate the fact of ethereal inertia.

Now return to consider what happens when a charged conductor (say a Leyden jar) is discharged. The recoil of the strained dielectric causes a current, the inertia of this current causes it to overshoot the mark, and for an instant the charge of the jar is reversed; the current now flows backward and charges the jar up as at first; back again flows the current, and so on, charging and reversing the charge with rapid oscillations until the energy is all dissipated into heat. The operation is precisely analogous to the release of a strained spring or to the plucking of a stretched string.

But the discharging body thus thrown into strong electrical vibration is embedded in the all-pervading ether, and we have just seen that the ether possesses the two properties requisite for the generation and transmission of waves—viz., elasticity and inertia or density; hence, just as a tuning fork vibrating in air excites aerial waves or sound, so a discharging Leyden jar in ether excites ethereal waves or light.

Ethereal waves can therefore be actually produced by direct electrical means. I discharge here a jar, and the room is for an instant filled with light. With light, I say, though you can see nothing. You can see and hear the spark indeed—but that is a mere secondary disturbance we can for the present ignore—I do not mean any secondary disturbance. I mean the true ethereal waves emitted by the electric oscillation going on in the neighborhood of this recoiling dielectric. You pull aside the prong of a tuning fork and let it go; vibration follows and sound is produced. You charge a Leyden jar and let it discharge; vibration follows and light is excited.

It is light just as good as any other light. It travels at the same pace, it is reflected and refracted according to the same laws; every experiment known to optics can be performed with this ethereal radiation electrically produced, and yet you cannot see it. Why not? For no fault of the light; the fault (if there be a fault) is in the eye. The retina is incompetent to respond to these vibrations—they are too slow. The vibrations set up when this large jar is discharged are from a hundred thousand to a million per second, but that is too slow for the retina. It responds only to vibrations between 4,000 billions and 7,000 billions per second. The vibrations are too quick for the ear, which responds only to vibrations between 40 and 40,000 per second. Between the highest audible and the lowest visible vibrations there has been hitherto a great gap, which these electric oscillations go far to fill up. There has been a great gap simply because we have no intermediate sense organ to detect rates of vibration between 40,000 and 4,000,000,000,000,000 per second. It was, therefore, an unexplored territory. Waves have been there all the time in any quantity, but we have not thought about them nor attended to them.

It happens that I have myself succeeded in getting electric oscillations so slow as to be audible. The lowest I have got at present are 125 per second, and for some way above this the sparks emit a musical note; but no one has yet succeeded in directly making electric oscillations which are visible, though indirectly every one does it when they light a candle.

Here, however, is an electric oscillator, which vibrates 300 million times a second, and emits ethereal waves a yard long. The whole range of vibrations between musical tones and some thousand million per second is now filled up.

These electro-magnetic waves have long been known on the side of theory, but interest in them has been immensely quickened by the discovery of a receiver or detector for them. The great though simple discovery by Hertz of an "electric eye," as Sir W. Thomson calls it, makes experiments on these waves for the first time easy or even possible. We have now a sort of artificial sense organ for their appreciation—an electric arrangement which can virtually "see" these intermediate rates of vibration.

The Hertz receiver is the simplest thing in the world—nothing but a bit of wire or a pair of bits of wire adjusted so that when immersed in strong electric radiation they give minute sparks across a microscopic air gap.

The receiver I have here is adapted for the yard-long waves emitted from this small oscillator; but for the far longer waves emitted by a discharging Leyden jar an excellent receiver is a gilt wall paper or other interrupted metallic surface. The waves falling upon the metallic surface are reflected, and in the act of reflection excite electric currents, which cause sparks. Similarly, gigantic solar waves may produce auroræ; and minute waves from a candle do electrically disturb the retina.

The smaller waves are, however, far the most interesting and the most tractable to ordinary optical experiments. From a small oscillator, which may be a couple of small

cylinders kept sparking into each other end to end by an induction coil, waves are emitted on which all manner of optical experiments can be performed.

They can be reflected by plain sheets of metal, concentrated by parabolic reflectors, refracted by prisms, concentrated by lenses. I have at the college a large lens of pitch, weighing over three hundredweight, for concentrating them to a focus. They can be made to show the phenomenon of interference, and thus have their wave length accurately measured. They are stopped by all conductors and transmitted by all insulators. Metals are opaque, but even imperfect insulators such as wood or stone are strikingly transparent, and waves may be received in one room from a source in another, the door between the two being shut.

The real nature of metallic opacity and of transparency has long been clear in Maxwell's theory of light, and these electrically produced waves only illustrate and bring home the well known facts. The experiments of Hertz are in fact the apotheosis of that theory.

Thus, then, in every way Maxwell's 1865 brilliant perception of the real nature of light is abundantly justified; and for the first time we have a true theory of light, no longer based upon analogy with sound, nor upon a hypothetical jelly or elastic solid.

Light is an electro-magnetic disturbance of the ether. Optics is a branch of electricity. Outstanding problems in optics are being rapidly solved now that we have the means of definitely exciting light with a full perception of what we are doing and of the precise mode of its vibration.

It remains to find out how to shorten down the waves—to hurry up the vibration until the light becomes visible. Nothing is wanted but quicker modes of vibrations. Smaller oscillators must be used—very much smaller—oscillators not much bigger than molecules. In all probability—one may almost say certainly—ordinary light is the result of electric oscillation in the molecules of hot bodies, or sometimes of bodies not hot—as in the phenomenon of phosphorescence.

The direct generation of *visible* light by electric means, so soon as we have learnt how to attain the necessary frequency of vibration, will have most important practical consequences.

Speaking in this university, it is happily quite unnecessary for me to bespeak interest in a subject by any reference to possible practical applications. But any practical application of what I have dealt with this evening is apparently so far distant as to be free from any sordid gloss of competition and company promotion, and is interesting in itself as a matter of pure science.

For consider our present methods of making artificial light; they are both wasteful and ineffective.

We want a certain range of oscillation, between 7,000 and 4,000 billion vibrations per second; no other is useful to us, because no other has any effect upon our retina; but we do not know how to produce vibrations of this rate. We can produce a definite vibration of one or two hundred or thousand per second; in other words, we can excite a pure tone of definite pitch; and we can demand any desired range of such tones continuously by means of bellows and a keyboard. We can also (though the fact is less well known) excite momentarily definite ethereal vibrations of some million per second, as I have explained at length; but we do not at present seem to know how to maintain this rate quite continuously. To get much faster rates of vibration than this we have to fall back upon atoms. We know how to make atoms vibrate; it is done by what we call "heating" the substance, and if we could deal with individual atoms unhampered by others, it is possible that we might get a pure and simple mode of vibration from them. It is possible, but unlikely; for atoms, even when isolated, have a multitude of modes of vibration special to themselves, of which only a few are of practical use to us, and we do not know how to excite some without also the others. However, we do not at present even deal with individual atoms; we treat them crowded together in a compact mass, so that their modes of vibration are really infinite.

We take a lump of matter, say a carbon filament or a piece of quicklime, and by raising its temperature we impress upon its atoms higher and higher modes of vibration, not transmuting the lower into the higher, but superposing the higher upon the lower, until at length we get such rates of vibration as our retina is constructed for, and we are satisfied. But how wasteful and indirect and empirical is the process. We want a small range of rapid vibrations, and we know no better than to make the whole series leading up to them. It is as though, in order to sound some little shrill octave of pipes in an organ, we are obliged to depress every key and every pedal, and to blow a young hurricane.

I have purposely selected as examples the more perfect methods of obtaining

artificial light, wherein the waste radiation is only useless and not noxious. But the old-fashioned plan was cruder even than this; it consisted simply in setting something burning; whereby not the fuel but the air was consumed, whereby also a most powerful radiation was produced, in the waste waves of which we were content to sit stewing, for the sake of the minute—almost infinitesimal—fraction of it which enabled us to see.

Every one knows now, however, that combustion is not a pleasant or healthy mode of obtaining light; but every one does not realize that neither is incandescence a satisfactory and unwasteful method which is likely to be practiced for more than a few decades, or perhaps a century.

Look at the furnaces and boilers of a great steam engine driving a group of dynamos, and estimate the energy expended; and then look at the incandescent filaments of the lamps excited by them, and estimate how much of their radiated energy is of real service to the eye. It will be as the energy of a pitch pipe to an entire orchestra.

It is not too much to say that a boy turning a handle could, if his energy were properly directed, produce quite as much real light as is produced by all this mass of mechanism and consumption of material. There might, perhaps, be something contrary to the laws of nature in thus hoping to get and utilize some specific kind of radiation without the rest, but Lord Rayleigh has shown in a short communication to the British Association at York that it is not so, and that, therefore, we have a right to try to do it.

We do not yet know how, it is true, but it is one of the things we have got to learn.

Any one looking at a common glow-worm must be struck with the fact that not by ordinary combustion, nor yet on the steam engine and dynamo principle, is that easy light produced. Very little waste radiation is there from phosphorescent things in general. Light of the kind able to affect the retina is directly emitted; and for this, for even a large supply of this, a modicum of energy suffices.

Solar radiation consists of waves of all sizes, it is true; but then solar radiation has innumerable things to do besides making things visible. The whole of its energy is useful. In artificial lighting nothing but light is desired; when heat is wanted it is best obtained separately by combustion. And so soon as we clearly recognize that light is an electric vibration, so soon shall we begin to beat about for some mode of exciting and maintaining an electrical vibration of any required degree of rapidity. When this has been accomplished the problem of artificial lighting will have been solved.

[1]

Being the general substance of a lecture to the Ashmolean Society in the University of Oxford, on Monday, June 3, 1889. [Reprinted from the *Liverpool University College Magazine*.]

[2]

Though, indeed, a century hence it may be premature to offer an opinion on such a point.

ON PURIFICATION OF AIR BY OZONE—WITH AN ACCOUNT OF A NEW METHOD.¹

By Dr. B. W. RICHARDSON.

During the time when I was engaged in my preliminary medical studies—for I never admit to this day of being anything less than a medical student—the substance called ozone became the topic of much conversation and speculation. I cannot say that ozone was a discovery of that date, for in the early part of the century Von Marum had observed that when electrical discharges were made through oxygen in a glass cylinder inverted over water, the water rose in the cylinder as if something had either been taken away from the gas, or as if the gas itself had been condensed, and was therefore occupying a smaller space. It had also been observed by many electricians that during a passage of the electric spark through air or oxygen, there was a peculiar emanation or odor which some compared to fresh sea air, others to the air after a thunderstorm, when the sky has become very clear, the firmament blue, and the stars, if visible, extremely bright.

But it was not until the time, or about the time, of which I have spoken, 1846-49, that these discovered but unexplained phenomena received proper recognition. The

distinguished physicist Schonbein first, if I may so say, isolated the substance which yielded the phenomena, and gave to it the name, by which it has since generally been known, of *ozone*, which means, to emit an odor; a name, I have always thought, not particularly happy, but which has become, practically, so fully recognized and understood, that it would be wrong now to disturb it.

Schonbein made ozone by the action of the electric spark on oxygen. He collected it, he tested its chemical properties, he announced it to be oxygen in a modified form, and he traced its action as an active oxidizer of various substances, and especially of organic substances, even when they were in a state of decomposition.

But Schonbein went further than this. He argued that ozone was a natural part of the atmosphere, and that in places where there was no decomposition, that is to say, in places away from great towns, ozone was present. On the high tower of a cathedral in a big city he discovered ozone; in the city, at the foot of the tower, he found no ozone at the same time. He argued, therefore, that the ozone above was used up in purifying the town below, and so suggested quite a new explanation of the purification of air.

The subject was very soon taken up by English observers, and I remember well a lecture upon it by Michael Faraday, in which that illustrious philosopher, confirming Schonbein, stated that he had discovered ozone freely on the Brighton Downs, and had found the evidence of it diminishing as he approached Brighton, until it was lost altogether in the town itself.

Such was the beginning of our knowledge of ozone, the precise nature of which has not yet been completely made out. At the present time it is held to be oxygen condensed. To use a chemical phrase, the molecule of oxygen, which in the ordinary state is composed of two atoms, is condensed, in ozone, as three atoms. By the electric spark discharged in dry oxygen as much as 15 per cent. may, under proper conditions, be turned into ozone. Ozone has also been found to be heavier than air. Professor Zinno says, that compared with an equal volume of air its density is equal to 1,658, and that it is forty-eight times heavier than hydrogen. Heat decomposes it; at the temperature of boiling water it begins to decompose. In water it is much less soluble than oxygen, and indeed is practically insoluble; when made to bubble through boiling water, it ceases to be ozone. The oxidizing power of ozone is very much greater than that of oxygen, and, according to Saret, when ozone is decomposed, one part of it enters into combination, the other remains simply as oxygen.

It is remarkable that some substances, like turpentine and cinnamon, absorb ozone and combine with it, a simple fact of much greater importance than has ever been attached to it. I found, for instance, that cinnamon which by exposure to the air has been made odorless and, as it is said, "spoiled," can be made to reabsorb ozone and gain a kind of freshness. It is certain also that some substances which are supposed to have disinfecting properties owe what virtues they possess to the presence of ozone.

On some grand scale ozone is formed in the air, and my former friend and colleague, the late Dr. Moffatt, of Hawarden, with whom I wrote a paper on "Meteorology and Disease," read before the Epidemiological Society in 1852-53, described what he designated ozone periods of the atmosphere, connecting these with storms. When the atmospheric pressure is decreasing, when with that there is increasing warmth and moisture, and when south and southwesterly winds prevail, then ozone is active; but when the atmospheric pressure is increasing, when the air is becoming dry and cold, and north and northeasterly winds prevail, then the presence of ozone is less active. These facts have also been put in another way, namely, that the maximum period of ozone occurs when there is greatest evaporation of water from the earth, and the minimum when there is greatest condensation of water on the earth; a theory which tallies well with the idea that ozone is most freely present when electricity is being produced, least present when electricity is in smallest quantity. Mr. Buchan, reporting on the observations of the Scottish Meteorological Society, records that ozone is most abundant from February to June, when the average amount is 6.0; and least from July to January, when the average is 5.7; the maximum, 6.2, being reached in May, and the minimum, 5.3, in November. This same excellent observer states that "ozone is more abundant on the sea coast than inland; in the west than the east of Great Britain; in elevated than in low situations; with southwest than with northeast winds; in the country than in towns; and on the windward than the leeward side of towns."

Recently a very singular hypothesis has been broached in regard to the blue color of the firmament and ozone. It has been observed that when a tube is filled with ozone, the light transmitted through it is of a blue color; from which fact it is assumed that the blue color of the sky is due to the presence of this body in the higher atmospheric strata. The hypothesis is in entire accord with the suggestion of Professor Dove, to which Moffatt always paid the greatest respect, viz., that the source of ozone for the

whole of the planet is equatorial, and that the point of development of ozone is where the terrestrial atmosphere raised to its highest altitude, at the equator, expands out north and south in opposite directions toward the two poles, to return to the equator over the earth as the trade winds.

It is necessary for all who would understand the applications of ozone for any purpose, whether for bleaching purposes or pure chemical purposes, or for medical or sanitary purposes, to understand these preliminary facts concerning it, facts which bring me to the particular point to which I wish to refer to-day.

In my essay describing the model city, Hygeiopolis, it was suggested that in every town there should be a building like a gas house, in which ozone should be made and stored, and from which it should be dispensed to every street or house at pleasure. This suggestion was made as the final result of observations which had been going on since I first began to work at the subject in 1852. It occurred to me from the moment when I first made ozone by Schonbein's method, that the value of it in a hygienic point of view was incalculable.

To my then young and enthusiastic mind it seemed that in ozone we had a means of stopping all putrefaction, of destroying all infectious substances, and of actually commanding and destroying the causes which produced the great spreading diseases; and, although increase of years and greater experience have toned down the enthusiasm, I still believe that here one of the most useful fields for investigation remains almost unexplored.

In my first experiments I subjected decomposing blood to ozone, and found that the products of decomposition were instantly destroyed, and that the fluid was rendered odorless and sweet. I discovered that the red corpuscles of fresh blood decomposed ozone, and that coagulated blood underwent a degree of solution through its action. I put dead birds and pieces of animal substances that had undergone extreme decomposition into atmospheres containing ozone, and observed the rapidity with which the products of decomposition were neutralized and rendered harmless. I employed ozone medicinally, by having it inhaled by persons who were suffering from fœtor of the breath, and with remarkable success, and I began to employ it and have employed it ever since (that is to say, for thirty-seven years), for purposes of disinfection and deodorization, in close rooms, closets, and the like. I should have used it much more largely but for one circumstance, namely, the almost impracticable difficulty of making it with sufficient ease and in sufficient quantities to meet the necessities of sanitary practice. We are often obstructed in this way. We know of something exceedingly useful, but we cannot utilize it. This was the case with ozone. I hope now that difficulty is overcome. If it is, we shall start from this day on a new era in regard to ozone as an instrument of sanitation.

As we have seen, ozone was originally made by charging dry oxygen or common dry air with electricity from sparks or points. Afterward Faraday showed that it could be made by holding a warm glass rod in vapor of ether. Again he showed that it could be made by passing air over bright phosphorus half immersed in water. Then Siemens modified the electric process by inventing his well known ozone tube, which consists of a wide glass tube coated with tinfoil on its outside, and holding within it a smaller glass tube coated with tinfoil on its surface. When a current of dry air or oxygen was passed in current between these two tubes, and the electric spark from a Ruhmkorf coil was discharged by the terminal wires connected with tinfoil surfaces, ozone was freely produced, and this was no doubt the best method, for by means of a double-acting hand bellows currents of ozone could be driven over very freely. One of these tubes with hand bellows attached, which I have had in use for twenty-four years, is before the meeting, and answers as well as ever. The practical difficulty lies in the requirement of a battery, a large coil, and a separate bellows as well as the tube.

My dear and most distinguished friend, the late Professor Polli, of Milan, tried to overcome the difficulties arising from the use of the coil by making ozone chemically, namely, by the decomposition of permanganate of potassa with strong sulphuric acid. He placed the permanganate in glass vessels, moistened it gradually with the acid, and then allowed the ozone, which is formed, to diffuse into the air. In this way he endeavored, as I had done, to purify the air of rooms, especially those vitiated by the breaths of many people. When he visited me, not very long before his death, he was enthusiastic as to the success that must attend the utilization of ozone for purification, and when I expressed a practical doubt, he rallied me by saying I must not desert my own child. At the theater La Scala, on the occasion of an unusually full attendance, Polli collected the condensable part of the exhaled organic matter, by means of a large glass bell filled with ice and placed over the circular opening in the roof, which corresponds with the large central light. The deposit on this bell was liquid and had a mouldy smell; was for some few days limpid, but then became very thick and had a nauseous odor. When mixed with a solution of one part glucose to four parts of water, and kept at a temperature of from 20° to 24° C., this liquid underwent a slow fermentation, with the formation, on the superficies, of a green must; during the same period of time, and placed under the same conditions, a

similar glucose solution underwent no change whatever.

By the use of his ozone bottles Polli believed that he had supplied a means most suitable for directly destroying in the air miasmatic principles, without otherwise interfering with the respiratory functions. The ozonized air had neither a powerful nor an offensive smell, and it might be easily and economically made. The smell of ozone was scarcely perceptible, and was far less disagreeable than chlorine, bromine, and iodine, while it was more efficacious than either of these; if, therefore, its application as a purifier of a vitiated air succeeded, it would probably supply all the exigences of defective ventilation in crowded atmospheres. In confined places vessels might be placed containing mixtures of permanganate of potassa or soda and acid in proper quantities, and of which the duration of the action was known; or sulphuric acid could be dropped upon the permanganate.

This idea of applying ozone was no doubt very ingenious, and in the bottles before us on the table, which have been prepared in Hastings by Mr. Rossiter, we see it in operation. The disadvantages of the plan are that manipulation with strong sulphuric acid is never an agreeable or safe process, and that the ozone evolved cannot be on a large scale without considerable trouble.

In 1875 Dr. Lender published a process for the production of ozone. In this process he used equal parts of manganese, permanganate of potash, and oxalic acid. When this mixture is placed in contact with water, ozone is quickly generated. For a room of medium size two spoonfuls of this powder, placed in a dish and occasionally diluted with water, would be sufficient. As the ozone is developed, it disinfects the surrounding air without producing cough.

Lender's process is very useful when ozone is wanted on a limited scale. We have some of it here prepared by Mr. Rossiter, and it answers exceedingly well; but it would be impossible to generate sufficient ozone by this plan for the large application that would be required should it come into general use. The process deserves to be remembered, and the physician may find it valuable as a means by which ozone may be medically applied, to wounds, or by inhalation when there are foetid exhalations from the mouth or nostrils.

A NEW METHOD.

For the past ten or fifteen years the manufacture of ozone, for the reasons related above, has remained in abeyance, and it is to a new mode, which will, I trust, mark another stage of advancement, that I now wish to direct attention. Some years since, Mr. Wimshurst, a most able electrician, invented the electrical machine which goes by his name. The machine, as will be seen from the specimen of it on the table, looks something like the old electrical machine, but differs in that there is no friction, and that the plates of glass with their metal sectors, separated a little distance from each other, revolve, when the handle of the machine is turned, in opposite directions. The machine when it is in good working order (and it is very easily kept in good working order) produces electricity abundantly, and in working it I observed that ozone was so freely generated, that more than once the air of my laboratory became charged with ozone to an oppressive degree. The fact led me to use this machine for the production of ozone on a large scale, in the following way.

From the terminals of the machine two wires are carried and are conducted, by their terminals, to an ozone generator formed somewhat after the manner of Siemens', but with this difference, that the discharge is made through a series of fine points within the cylinders. The machine is placed on a table with the ozone generator at the back of it, and can be so arranged that with the turning of the handle which works the machine a blast of air is carried through the generator. Thus by one action electricity is generated, sparks are discharged in the ozone generator, air is driven through, and ozone is delivered over freely.

If it be wished to use pure oxygen instead of common air, nothing more is required than to use compressed oxygen and to allow a gentle current to pass through the ozone generator in place of air. For this purpose Brin's compressed oxygen is the purest and best; but for ordinary service atmospheric air is sufficient.²

The advantages of this apparatus are as follows:

1. With care it is always ready for use, and as no battery is required nor anything more than the turning of a handle, any person can work it.
2. It can be readily moved about from one part of a room or ward to another part.
3. If required for the sick it can be wheeled near the bedside and, by a tube, the ozone it emits can be brought into action in any way desired by the physician.

I refer in the above to the minor uses of ozone by this method, but I should add that

it admits of application on a much grander scale. It would now be quite easy in any public institution to have a room in which a large compound Wimshurst could be worked with a gas engine, and from which, with the additional apparatus named, ozone could be distributed at pleasure into any part of the building. On a still larger scale ozone could be supplied to towns by this method, as suggested in Hygeiopolis, the model city.

It will occur, I doubt not, to the learned president of this section, and to others of our common profession, that care will have to be taken in the application of ozone that it be used with discretion. This is true. It has been observed in regard to diseases, that in the presence of some diseases ozone is absent in the atmosphere, but that with other diseases ozone is present in abundance. During epidemics of cholera, ozone is at a minimum. During other epidemics, like influenza, it has been at a maximum. In our paper Dr. Moffatt and I classified diseases under both conditions, and the difference must never be forgotten, since in some diseases we might by the use of ozone do mischief instead of good. Moreover, as my published experiments have shown, prolonged inhalation of ozone produces headache, coryza, soreness of the eyes, soreness of the throat, general malaise, and all the symptoms of severe influenza cold. Warm-blooded animals, also, exposed to it in full charge, suffer from congestion of the lungs, which may prove rapidly fatal. With care, however, these dangers are easily avoided, the point of practice being never to charge the air with ozone too abundantly or too long.

A simple test affords good evidence as to presence of ozone. If into twenty ounces of water there be put one ounce of starch and forty grains of potassium iodide, and the whole be boiled together, a starch will be made which can be used as a test for ozone. If ozone be passed through this starch the potassium is oxidized, and the iodine, set free, strikes a blue color with the starch. Or bibulous paper can be dipped in the starch, dried and cut into slips, and these slips being placed in the air will indicate when ozone is present. In disinfecting or purifying the air of a room with ozone, there is no occasion to stop until the test paper, by change of color, shows that the ozone has done its work of destroying the organic matter which is the cause of impurity or danger. For my own part, I have never seen the slightest risk from the use of ozone in an impure air. The difficulty has always been to obtain sufficient ozone to remove the impurity, and it is this difficulty which I hope now to have conquered.—*The Asclepiad*.

[1]

Paper read in Section C, Domestic Health, at the Hastings Health Congress, on Friday, May 3, 1889.

[2]

For illustration to-day, Messrs Mayfield, the electrical engineers of Queen Victoria Street, E. C., have been good enough to lend me a machine fitted up on the plan named. It works so effectively that I can make the ozone given off from it detectable in every part of this large hall.

HEAT IN MAN.

At a recent meeting of the Physiological Society of Berlin, Prof. Zuntz spoke on heat regulation in man, basing his remarks on experiments made by Dr. Loewy. The store of heat in the human body at any one time is very large, equal, in fact, to nearly all the heat produced by the body during twenty hours, hence the heat given off to a calorimeter during a given period cannot be taken as a measure of the heat production. This determination must be based rather upon the amount of oxygen consumed and of carbonic acid gas given off. The purpose of the experiments was to ascertain what alteration the gaseous interchange of the body undergoes by the application of cold, inasmuch as existing data on this point are largely contradictory.

The observations were made on a number of men whose respiratory gases were compared, during complete rest, when they were at one time clothed, at another time naked, at temperatures from 12° to 15° C., and in warm and cold baths. Each experiment lasted from half an hour to an hour, during which period the gases were repeatedly analyzed. As a result of fifty-five experiments, twenty showed no alteration of oxygen consumption as the result of cooling, nine gave a lessened consumption, while the remaining twenty-six showed an increased using up of oxygen. This diversity of result is explicable on the basis of observations made by Prof. Zuntz, who was himself experimented upon, as to his subjective heat sensations during the experiments. He found that after the first impression due to the application of cold is overcome, it was quite easy to maintain himself in a perfectly passive condition; subsequently it required a distinct effort of the will to refrain from

shivering and throwing the muscles into activity, and finally even this became no longer possible, and involuntary shivering and muscular contraction supervened, as soon as the body temperature (*in ano*) had fallen $\frac{1}{2}^{\circ}$ to 1° C. During the first stage of cooling, Zuntz's oxygen consumption showed a uniform diminution; during the period also in which shivering was repressed by an effort of the will, cooling led to no increased consumption of oxygen, but as soon as shivering became involuntary there was at once an increased using up of oxygen and excretion of carbonic acid.

This explains the differences in the results of Dr. Loewy's experiments, and may be taken to show that in man, and presumably in *large* animals, heat regulation is directly dependent upon alteration (fall) in temperature of the surrounding medium does not exist; the increased heat production is rather the outcome of the movements resulting from the application of cold to the body. In *small* animals, on the other hand, there undoubtedly exists a heat regulation dependent upon an increased activity of chemical changes in the tissues set up by the application of cold to the surface of the body, and in this case the thermotaxic centers in the brain most probably play some part.—Dr. Herter gave an account of experiments made by Dr. Popoff on the artificial digestion of various and variously cooked meats. Lean beef and the flesh of eels and flounders were digested in artificial gastric juice; the amount of raw flesh thus peptonized was in all cases greater than that of cooked meat similarly treated. The flesh was shredded and heated by steam to 100° C. The result was the same for beef as for fish. When compared with each other, beef was, on the whole, the most digestible, but the amount of fish flesh which was peptonized was sufficiently great to do away with the evil repute which fish still has in Germany as a proteid food. Smoked meat differed in no essential extent from raw meat as regards its digestibility.

PRESERVATION OF SPIDERS FOR THE CABINET.

For several years past, I have devoted a portion of my leisure time to the arrangement of the collection of Arachnidæ of the Natural History Museum of the University of Gand. This collection, which is partially a result of my own captures, is quite a large one, for a university museum, since it comprises more than six hundred European and foreign specimens. Each group of individuals of the small forms and each individual of the large forms is contained in a bottle of alcohol closed with a ground glass stopper, and, whenever possible, the specimens have been spread out and fixed upon strips of glass.

The loss of alcohol through evaporation is almost entirely prevented by paraffining the stoppers and tying a piece of bladder over them.

Properly labeled, the series has a very satisfactory aspect, and is easily consulted for study. The reader, however, will readily understand how much time and patience such work requires, and can easily imagine how great an amount of space the collection occupies, it being at least twenty times greater than that that would be taken up by a collection of an equal number of insects mounted in the ordinary way on pins and kept in boxes.

These inconveniences led me to endeavor to find out whether there was not some way of preserving spiders, properly so called, in a dry state, and without distortion or notable modification of their colors.

Experience long ago taught me that pure and simple desiccation, after a more or less prolonged immersion in alcohol, gives passable results only with scorpions, galeodes, phrynes, and mygales, and consequently with arachnides having thick integuments, while it is entirely unsuccessful with most of the spiders. The abdomen of these shrivels, the characteristic colors disappear in great part, and the animals become unrecognizable.

Something else was therefore necessary, and I thought of carbolated glycerine. My process, which I have tried only upon the common species of the country—*Teegenaria domestica*, *Epeira cucurbitina*, *Zilla inclinata*, etc., having furnished me with preparations that were generally satisfactory. I think I shall be doing collectors a service by publishing it in the *Naturaliste*.

The specimens should first be deprived of moisture, that is to say, they should be allowed to remain eight or ten days in succession in 50 per cent. alcohol and in pure commercial alcohol. Absolute alcohol is not necessary.

After being taken from the alcohol, and allowed to drain, the specimens are immersed in a mixture compound of

Pure glycerine 2 volumes,

Pure carbolic acid in crystals 1 volume.

In this they ought to remain at least a week, but there will be no harm if they are left therein indefinitely, so that the collections of summer may be mounted during winter evenings.

What follows is a little more delicate, although very easy. After being removed from the carbolated glycerine, the spiders are placed upon several folds of white filtering paper, and are changed from time to time until the greatest part of the liquid has been absorbed. An insect pin is then passed through the cephalothorax of each individual and is inserted in the support upon which the final desiccation is to take place. This support consists of a piece of sheet cork tacked or glued at the edges to a piece of wood at least one inch in thickness. Upon the cork are placed four or five folds of filtering paper, so that the ventral surface of the pinned spider is in contact with this absorbing surface. For the rest, the legs, palpi, spinnerets, etc., are spread out by means of fine pins, precisely as would be done in the case of coleoptera.

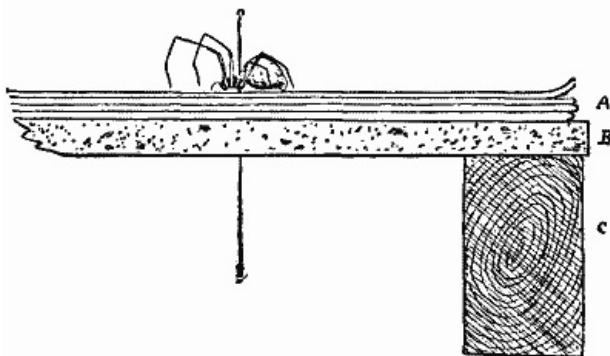

SETTING BOARD FOR SPIDERS.

A. Absorbent papers. B. Sheet cork. C. Wooden support.

The setting board is put for two or three months in a very dry place under cover from dust.

The spiders thus treated will scarcely have changed in appearance, the abdomen of the largest *Epeiras* will have preserved its form, the hairs will in nowise have become agglutinated, and a person would never suspect that glycerine had performed the role.

The forms with a large abdomen require a special precaution; it is necessary to pass the mounting pin through a piece of thin cardboard or of gelatine prolonged behind under the abdomen, because the latter is heavy, and the pedicel that connects it with the cephalothorax easily breaks.

The specimens are mounted in boxes lined with cork, just as insects are.

As there is nothing simpler than to have in one's laboratory three bottles, two of them containing alcohol and the other containing carbolated glycerine, and as it is easy to make setting boards capable of holding from twenty to thirty individuals at once, it will be seen that, with a little practice, the method is scarcely any more complicated than the one daily employed for coleoptera and orthoptera, which latter, too, must pass through alcohol, and be pinned, spread out, and dried. There are but two additional elements, carbolated glycerine and absorbent paper. I do not estimate the time necessary for desiccation as being very long, since the zoologist can occupy himself with other subjects while the specimens are drying. Let us add that the process renders the preservation indefinite, and that destructive insects are not to be feared. Some vertebrates, such as monkeys, that I preserved in the flesh ten years ago, by a nearly identical method, are still intact—*F. Plateau, in Le Naturaliste*.

DRIED WINE GRAPES.

According to a report of the Committee of the Grape Growers' and Wine Maker's Association of California, the drying of wine grapes on a large scale was begun during the vintage season of 1887, in which season about eight carloads in all were made and sold, the bulk of which came from the vicinity of Fresno; that year, the committee are informed, the growers netted about three and a half cents per pound. During the season of 1888 about 112 carloads were dried, packed, and sold, netting the growers from two and a half to three and a half cents per pound, depending on the quality of the fruit. The great bulk of that year's product has entered into consumption, but there yet remains unsold to consumers, we are informed, about ten carloads, which, it is expected, will be sold during the next three months. It has been

observed by those handling this product that the largest sales of dried wine grapes in 1888 and 1889 took place at those points to which the first lots were shipped in 1887, which would show that as the product becomes better known it finds a readier market.

Dried wine grapes are prepared in a similar manner to raisins; that is they are dried in the sun, but do not require the same care in handling that are given to raisins. Wooden trays 2 × 3 are sometimes used, but it is by no means necessary to go to the expense of procuring trays, as it has been found that a good quality of coarse brown paper will answer every purpose, and this, with care, may be made to last two or three seasons. The drying was last season principally done on the bare ground, but there is much loss by shelling, as those dried are required to be turned; a pitchfork is used for that purpose. Brown building paper can be procured of city paper dealers in large rolls at four and a half cents per pound; according to the thickness, it will cost from one and three-quarters to three and a half cents per square yard. A thin, tough, waterproof paper is also made in rolls at about six cents a square yard. Wine grapes dry in from ten days to three weeks, according to variety and weather, and with the exception of Malvoisie, Rose of Peru, and Black Hamburg, from three and a half to four and a half tons of the green fruit are required to make one of the dried; these three varieties, however, being large, meaty, and a firm pulp, do not require more than from three to three and a half tons of the green fruit to produce one ton of dried, and are, therefore, the most profitable for drying; they also command better values in the market. The grapes are sufficiently dried when, on being rolled between the thumb and finger, no moisture exudes, and also when the stems are found to be dry and brittle, so that they can be separated readily from the berries. After the grapes have reached the proper state of dryness, they are taken in boxes or sacks to the packing house, where they are stemmed and cleaned, after which they are packed in white cotton sacks, holding from fifty to seventy-five pounds each, and when marked are ready for shipment.

The stemming and cleaning of the dried grapes is done by special machines designed for that purpose, which leaves the fruit in a bright, clean condition attractive to purchasers. These machines are at present built only by James Porteous, Fresno, and are operated either by hand or power. The cost of a stemmer and cleaner complete is \$80, f. o. b. cars at Fresno. Where several producers can do so, it would be advisable to club together and get the machine in this way. Much extra expense could be avoided and one set of machinery would serve several vineyards, possibly an entire district where time was not a great object; or some one person in a district could purchase an outfit and do the work by contract, going from place to place. The capacity of the stemmer and cleaner is from five to eight tons per day, when the grapes are in proper condition; and the cost or charge for stemming, cleaning, sacking, and sewing up the sacks is from four to five dollars per ton when the producer furnishes the sacks. Good cotton sacks, holding about seventy-five pounds, cost from eight to ten cents each, including the necessary twine. Last year dried grapes were generally sold for cash, f. o. b., but it is probable that other markets could be secured by selling on consignment.

As to the advisability of such a course, each producer must himself be the judge. It is, however, quite certain that until consumers have an opportunity to try this product, the sales will necessarily be more or less limited, unless vigorously pushed by merchants and others interested in extending the markets for California products in the Eastern cities not yet tried. The varieties most suitable and profitable for drying, and especially for consumption in the Eastern markets, are the Malvoisie, Rose of Peru, Black Hamburg, Mission, Zinfandel, Charbono, Grenache, and in some localities the Carignan, of the dark varieties, and the Feher Zagos and Golden Chasselas of the white grapes; there are many other white grapes that are excellent when dried, but are too valuable for wine-making purposes, or are too small or deficient in sugar for use as dried grapes.

The same is true of the dark grapes, some of which ripen so late that it would be impossible to dry them in the sun, and the use of artificial heat is, at present prices, too expensive. Therefore, the varieties mentioned, which generally mature early, are found to be the most suitable for this purpose. This product is sold by dealers in the Eastern cities for cooking purposes, and as a substitute for dried fruits, such as peaches, apples, apricots, etc., in comparison with which it is usually much cheaper; while for stewing and for puddings and pies it answers the same purpose. The demand for this product will probably be gauged by the Eastern fruit crop; that is, the quantity that can be disposed of will depend upon the quantity of Eastern fruit in the market, and the prices will be largely dependent upon that of dried fruit.

WALNUT OIL.

This oil, which I obtained from the fully ripened nut of the *Juglans regia*, has so many excellent properties, especially for mixing with artists' colors for fine art work, that I am surprised at the small amount of information available on this interesting oil.

Walnut oil is largely used for adulterating olive oil, and to compensate for its high iodine absorption it is mixed with pure lard oil olein, which also retards the thickening effect due to oxidation. The marc left on expression of the oil is said to be largely used in the manufacture of chocolate. Many people, I am told, prefer walnut oil to olive oil for cooking purposes.

The value of this oil for out-door work has been given me by a friend who used it for painting the verandas and jalousies of his house (near Como, Italy) some twenty years ago, and which have not required painting since. In this country, at least, walnut oil is beyond the reach of the general painter, and I do not know that the pure oil is to be obtained as a commercial article, even on a small scale.

It was in examining the properties of this and other oils, used as adulterants of olive oil, that I was obliged to prepare them so as to be sure of getting them in a reliable condition as regards purity. The walnuts were harvested in the autumn of 1887, and kept in a dry airy room until the following March. The kernels had shrunk up and contracted a disagreeable acrid taste, so familiar with old olive oil in which this has been used as an adulterant. Most oxidized oils, especially cotton seed oil, reveal a similar acrid taste, but walnut oil has, in addition, an unmistakable increase in viscosity. The nuts were opened and the kernels thrown into warm water, so as to loosen the epidermis; they were then rubbed in a coarse towel, so as to blanch them. The decorticated nuts were wiped dry and rubbed to a smooth paste in a marble mortar. The paste was first digested in CS_2 , then placed in a percolator and exhausted with the same solvent, which was evaporated off. The yield of oil was small, but probably, if the nuts had been left to fully ripen on the trees without knocking them off, the yield might have been greater. It is by no means improbable that oxidation may have rendered a portion of the oil insoluble. The decorticated kernels gave a perfectly sweet, inodorous, and almost colorless oil, which rapidly thickens to an almost colorless, transparent, and perfectly elastic skin or film, which does not darken or crack easily by age. These are properties which, for fine art painting, might be of great value in preserving the tinctorial purity and freshness of pigments.

Sulphur chloride gives a perfectly white product with the fresh oil, but, when oxidized, the product is very dark, almost black. The iodine absorption of the fresh oil thus obtained is very high, but falls rapidly by oxidation or blowing. A curious fact has been disclosed with reference to the oxidation of this and similar oils. If such an oil be mixed with lard oil, olive oil, or sperm oil, it thickens by oxidation, but is perfectly soluble. Such a mixture is largely used in weaving or spinning. Commercial samples of linseed oil, when cold-drawn, have a much higher iodine absorption, probably due to the same cause. Oils extracted by CS_2 are very much higher than the same oils, especially if hot-pressed.—*Chem. News*.

THE PYRO DEVELOPER WITH METABISULPHITE OF POTASH.

By Dr. J. M. EDER.

Lately I called attention to the metabisulphite of potassium as an addition to the pyro solution for development, and can give now some of my experiences with this salt.

The metabisulphite of potassium, which was introduced into the market by Dr. Schuchardt, and whose correct analysis is not known yet, is a white crystal, which in a solid condition, as well as in an aqueous solution, has a strong smell of sulphurous acid. An aqueous 2 per cent. solution of this salt dissolves pyrogallol acid to a weak yellowish color, being distinguished from the more light brown solution of sulphite of soda and pyro. The solution kept very well for four weeks in half-filled bottles, and showed a better preservation than the usual solution of pyro and sulphite of soda. More than 2 per cent. of the metabisulphite of potassium is without any advantage. If this solution is mixed with soda, a picture will develop rapidly, but the same will show a strongly yellow coloration in the gelatine film. Sulphite of soda has to be added to the soda solution to obtain an agreeable brownish or black tone in the negatives.

If the contents of metabisulphite and pyro-soda developer are increased, it will act

very slowly; larger quantities of the metabisulphite of potassium, therefore, act like a strong retarder. In small quantities there is no injurious retarding action, but it will have the effect that the plates obtain very clear shadows in this developer, and that the picture appears slower, and will strengthen more slowly. The strongly retarding action of larger quantities of metabisulphite might be accounted for in that the bisulphite will give, with the carbonate of soda, monosulphite and soda bicarbonate, which latter is not a strong enough alkali to develop the bromide of silver strongly with pyro. An increase of soda compensates this retarding action of the metabisulphite of potassium.

Good results were obtained by me with this salt after several tests, by producing the following solutions:

A.	
Pyrogallic acid	4 grammes.
Metabisulphite of potassium	1½ "
Water	100 c. c.

This solution keeps for weeks in corked bottles.

B.	
Crystallized soda	10 grammes.
Neutral sulphite of soda	15 "
Water	100 c. c.

Before using mix—

Pyro solution A	20 c. c.
Soda solution B	20 "
Water	20 "

The developer acts about one and a half times slower than the ordinary pyro soda developer, approaching to the latter pretty nearly, and gives to the negatives an agreeable color and softness, with clear shadows. If the negatives are to be thinner, more water, say 30 to 40 c. c., is taken. If denser, then the soda is increased, and the water in the developer is reduced. An alum bath before fixing is to be recommended.

An advantage of this development is the great durability of the pyro-meta sulphite solution. The cost price is about the same as that of the ordinary pyro developer. At all events, it is worth while to make further investigation with the metabisulphite of potassium, the same being also a good preservative for hydroquinone solutions. —*Photographische Correspondenz; Reported in the Photo. News.*

A New Catalogue of Valuable Papers

Contained in SCIENTIFIC AMERICAN SUPPLEMENT during the past ten years, sent *free of charge* to any address.

MUNN & CO., 361 Broadway, New York.

THE SCIENTIFIC AMERICAN Architects and Builders Edition.

\$2.50 a Year. Single Copies, 25 cts.

This is a Special Edition of the SCIENTIFIC AMERICAN, issued monthly—on the first day of the month. Each number contains about forty large quarto pages, equal to about two hundred ordinary book pages, forming, practically, a large and splendid **Magazine of Architecture**, richly adorned with *elegant plates in colors* and with fine engravings, illustrating the most interesting examples of modern Architectural Construction and allied subjects.

A special feature is the presentation in each number of a variety of the latest and best plans for private residences, city and country, including those of very moderate cost as well as the more expensive. Drawings in perspective and in color are given,

together with full Plans, Specifications, Costs, Bills of Estimate, and Sheets of Details.

No other building paper contains so many plans, details, and specifications regularly presented as the *SCIENTIFIC AMERICAN*. Hundreds of dwellings have already been erected on the various plans we have issued during the past year, and many others are in process of construction.

Architects, Builders, and Owners will find this work valuable in furnishing fresh and useful suggestions. All who contemplate building or improving homes, or erecting structures of any kind, have before them in this work an almost *endless series of the latest and best examples* from which to make selections, thus saving time and money.

Many other subjects, including Sewerage, Piping, Lighting, Warming, Ventilating, Decorating, Laying out of Grounds, etc., are illustrated. An extensive Compendium of Manufacturers' Announcements is also given, in which the most reliable and approved Building Materials, Goods, Machines, Tools, and Appliances are described and illustrated, with addresses of the makers, etc.

The fullness, richness, cheapness, and convenience of this work have won for it the **Largest Circulation** of any Architectural publication in the world.

A Catalogue of valuable books on Architecture, Building, Carpentry, Masonry, Heating, Warming, Lighting, Ventilation, and all branches of industry pertaining to the art of Building, is supplied free of charge, sent to any address.

**MUNN & CO., Publishers,
361 Broadway, New York.**

Building Plans and Specifications.

In connection with the publication of the BUILDING EDITION of the *SCIENTIFIC AMERICAN*, Messrs. Munn & Co. furnish plans and specifications for buildings of every kind, including Churches, Schools, Stores, Dwellings, Carriage Houses, Barns, etc.

In this work they are assisted by able and experienced architects. Full plans, details, and specifications for the various buildings illustrated in this paper can be supplied.

Those who contemplate building, or who wish to alter, improve, extend, or add to existing buildings, whether wings, porches, bay windows, or attic rooms, are invited to communicate with the undersigned. Our work extends to all parts of the country. Estimates, plans, and drawings promptly prepared. Terms moderate. Address

MUNN & CO., Publishers, 361 BROADWAY, NEW YORK.

THE Scientific American Supplement.

PUBLISHED WEEKLY.

Terms of Subscription, \$5 a year.

Sent by mail, postage prepaid, to subscribers in any part of the United States or Canada. Six dollars a year, sent, prepaid, to any foreign country.

All the back numbers of *THE SUPPLEMENT*, from the commencement, January 1, 1876, can be had. Price, 10 cents each.

All the back volumes of *THE SUPPLEMENT* can likewise be supplied. Two volumes are issued yearly. Price of each volume, \$2.50 stitched in paper, or \$3.50 bound in stiff covers.

COMBINED RATES.—One copy of *SCIENTIFIC AMERICAN* and one copy of *SCIENTIFIC AMERICAN SUPPLEMENT*, one year, postpaid, \$7.00.

A liberal discount to booksellers, news agents, and canvassers.

**MUNN & CO., Publishers,
361 Broadway, New York, N. Y.**

Useful Engineering Books

Manufacturers, Agriculturists, Chemists, Engineers, Mechanics, Builders, men of leisure, and professional men, of all classes, need good books in the line of their respective callings. Our post office department permits the transmission of books through the mails at very small cost. A comprehensive catalogue of useful books by different authors, on more than fifty different subjects, has recently been published, for free circulation, at the office of this paper. Subjects classified with names of author. Persons desiring a copy have only to ask for it, and it will be mailed to them. Address,

MUNN & CO., 361 Broadway, New York.

PATENTS.

In connection with the **Scientific American**, Messrs. MUNN & Co. are solicitors of American and Foreign Patents, have had 42 years' experience, and now have the largest establishment in the world. Patents are obtained on the best terms.

A special notice is made in the **Scientific American** of all inventions patented through this Agency, with the name and residence of the Patentee. By the immense circulation thus given, public attention is directed to the merits of the new patent, and sales or introduction often easily effected.

Any person who has made a new discovery or invention can ascertain, free of charge, whether a patent can probably be obtained, by writing to MUNN & Co.

We also send free our Hand Book about the Patent Laws, Patents, Caveats, Trade Marks, their costs and how procured. Address

**MUNN & CO.,
361 Broadway, New York.**

Branch Office, 622 and 624 F St., Washington, D. C.

*** END OF THE PROJECT GUTENBERG EBOOK SCIENTIFIC AMERICAN
SUPPLEMENT, NO. 717, SEPTEMBER 28, 1889 ***

Updated editions will replace the previous one—the old editions will be renamed.

Creating the works from print editions not protected by U.S. copyright law means that no one owns a United States copyright in these works, so the Foundation (and you!) can copy and distribute it in the United States without permission and without paying copyright royalties. Special rules, set forth in the General Terms of Use part of this license, apply to copying and distributing Project Gutenberg™ electronic works to protect the PROJECT GUTENBERG™ concept and trademark. Project Gutenberg is a registered trademark, and may not be used if you charge for an eBook, except by following the terms of the trademark license, including paying royalties for use of the Project Gutenberg trademark. If you do not charge anything for copies of this eBook, complying with the trademark license is very easy. You may use this eBook for nearly any purpose such as creation of derivative works, reports, performances and research. Project Gutenberg eBooks may be modified and printed and given away—you may do practically ANYTHING in the United States with eBooks not protected by U.S. copyright law. Redistribution is subject to the trademark license, especially commercial redistribution.

START: FULL LICENSE
THE FULL PROJECT GUTENBERG LICENSE
PLEASE READ THIS BEFORE YOU DISTRIBUTE OR USE THIS WORK

To protect the Project Gutenberg™ mission of promoting the free distribution of electronic works, by using or distributing this work (or any other work associated in any way with the phrase "Project Gutenberg"), you agree to comply with all the terms of the Full Project Gutenberg™ License available with this file or online at www.gutenberg.org/license.

Section 1. General Terms of Use and Redistributing Project

Gutenberg™ electronic works

1.A. By reading or using any part of this Project Gutenberg™ electronic work, you indicate that you have read, understand, agree to and accept all the terms of this license and intellectual property (trademark/copyright) agreement. If you do not agree to abide by all the terms of this agreement, you must cease using and return or destroy all copies of Project Gutenberg™ electronic works in your possession. If you paid a fee for obtaining a copy of or access to a Project Gutenberg™ electronic work and you do not agree to be bound by the terms of this agreement, you may obtain a refund from the person or entity to whom you paid the fee as set forth in paragraph 1.E.8.

1.B. “Project Gutenberg” is a registered trademark. It may only be used on or associated in any way with an electronic work by people who agree to be bound by the terms of this agreement. There are a few things that you can do with most Project Gutenberg™ electronic works even without complying with the full terms of this agreement. See paragraph 1.C below. There are a lot of things you can do with Project Gutenberg™ electronic works if you follow the terms of this agreement and help preserve free future access to Project Gutenberg™ electronic works. See paragraph 1.E below.

1.C. The Project Gutenberg Literary Archive Foundation (“the Foundation” or PGLAF), owns a compilation copyright in the collection of Project Gutenberg™ electronic works. Nearly all the individual works in the collection are in the public domain in the United States. If an individual work is unprotected by copyright law in the United States and you are located in the United States, we do not claim a right to prevent you from copying, distributing, performing, displaying or creating derivative works based on the work as long as all references to Project Gutenberg are removed. Of course, we hope that you will support the Project Gutenberg™ mission of promoting free access to electronic works by freely sharing Project Gutenberg™ works in compliance with the terms of this agreement for keeping the Project Gutenberg™ name associated with the work. You can easily comply with the terms of this agreement by keeping this work in the same format with its attached full Project Gutenberg™ License when you share it without charge with others.

1.D. The copyright laws of the place where you are located also govern what you can do with this work. Copyright laws in most countries are in a constant state of change. If you are outside the United States, check the laws of your country in addition to the terms of this agreement before downloading, copying, displaying, performing, distributing or creating derivative works based on this work or any other Project Gutenberg™ work. The Foundation makes no representations concerning the copyright status of any work in any country other than the United States.

1.E. Unless you have removed all references to Project Gutenberg:

1.E.1. The following sentence, with active links to, or other immediate access to, the full Project Gutenberg™ License must appear prominently whenever any copy of a Project Gutenberg™ work (any work on which the phrase “Project Gutenberg” appears, or with which the phrase “Project Gutenberg” is associated) is accessed, displayed, performed, viewed, copied or distributed:

This eBook is for the use of anyone anywhere in the United States and most other parts of the world at no cost and with almost no restrictions whatsoever. You may copy it, give it away or re-use it under the terms of the Project Gutenberg License included with this eBook or online at www.gutenberg.org. If you are not located in the United States, you will have to check the laws of the country where you are located before using this eBook.

1.E.2. If an individual Project Gutenberg™ electronic work is derived from texts not protected by U.S. copyright law (does not contain a notice indicating that it is posted with permission of the copyright holder), the work can be copied and distributed to anyone in the United States without paying any fees or charges. If you are redistributing or providing access to a work with the phrase “Project Gutenberg” associated with or appearing on the work, you must comply either with the requirements of paragraphs 1.E.1 through 1.E.7 or obtain permission for the use of the work and the Project Gutenberg™ trademark as set forth in paragraphs 1.E.8 or 1.E.9.

1.E.3. If an individual Project Gutenberg™ electronic work is posted with the permission of the copyright holder, your use and distribution must comply with both paragraphs 1.E.1 through 1.E.7 and any additional terms imposed by the copyright holder. Additional terms will be linked to the Project Gutenberg™ License for all works posted with the permission of the copyright holder found at

the beginning of this work.

1.E.4. Do not unlink or detach or remove the full Project Gutenberg™ License terms from this work, or any files containing a part of this work or any other work associated with Project Gutenberg™.

1.E.5. Do not copy, display, perform, distribute or redistribute this electronic work, or any part of this electronic work, without prominently displaying the sentence set forth in paragraph 1.E.1 with active links or immediate access to the full terms of the Project Gutenberg™ License.

1.E.6. You may convert to and distribute this work in any binary, compressed, marked up, nonproprietary or proprietary form, including any word processing or hypertext form. However, if you provide access to or distribute copies of a Project Gutenberg™ work in a format other than “Plain Vanilla ASCII” or other format used in the official version posted on the official Project Gutenberg™ website (www.gutenberg.org), you must, at no additional cost, fee or expense to the user, provide a copy, a means of exporting a copy, or a means of obtaining a copy upon request, of the work in its original “Plain Vanilla ASCII” or other form. Any alternate format must include the full Project Gutenberg™ License as specified in paragraph 1.E.1.

1.E.7. Do not charge a fee for access to, viewing, displaying, performing, copying or distributing any Project Gutenberg™ works unless you comply with paragraph 1.E.8 or 1.E.9.

1.E.8. You may charge a reasonable fee for copies of or providing access to or distributing Project Gutenberg™ electronic works provided that:

- You pay a royalty fee of 20% of the gross profits you derive from the use of Project Gutenberg™ works calculated using the method you already use to calculate your applicable taxes. The fee is owed to the owner of the Project Gutenberg™ trademark, but he has agreed to donate royalties under this paragraph to the Project Gutenberg Literary Archive Foundation. Royalty payments must be paid within 60 days following each date on which you prepare (or are legally required to prepare) your periodic tax returns. Royalty payments should be clearly marked as such and sent to the Project Gutenberg Literary Archive Foundation at the address specified in Section 4, “Information about donations to the Project Gutenberg Literary Archive Foundation.”
- You provide a full refund of any money paid by a user who notifies you in writing (or by e-mail) within 30 days of receipt that s/he does not agree to the terms of the full Project Gutenberg™ License. You must require such a user to return or destroy all copies of the works possessed in a physical medium and discontinue all use of and all access to other copies of Project Gutenberg™ works.
- You provide, in accordance with paragraph 1.F.3, a full refund of any money paid for a work or a replacement copy, if a defect in the electronic work is discovered and reported to you within 90 days of receipt of the work.
- You comply with all other terms of this agreement for free distribution of Project Gutenberg™ works.

1.E.9. If you wish to charge a fee or distribute a Project Gutenberg™ electronic work or group of works on different terms than are set forth in this agreement, you must obtain permission in writing from the Project Gutenberg Literary Archive Foundation, the manager of the Project Gutenberg™ trademark. Contact the Foundation as set forth in Section 3 below.

1.F.

1.F.1. Project Gutenberg volunteers and employees expend considerable effort to identify, do copyright research on, transcribe and proofread works not protected by U.S. copyright law in creating the Project Gutenberg™ collection. Despite these efforts, Project Gutenberg™ electronic works, and the medium on which they may be stored, may contain “Defects,” such as, but not limited to, incomplete, inaccurate or corrupt data, transcription errors, a copyright or other intellectual property infringement, a defective or damaged disk or other medium, a computer virus, or computer codes that damage or cannot be read by your equipment.

1.F.2. LIMITED WARRANTY, DISCLAIMER OF DAMAGES - Except for the “Right of Replacement or Refund” described in paragraph 1.F.3, the Project Gutenberg Literary Archive Foundation, the owner of the Project Gutenberg™ trademark, and any other party distributing a Project Gutenberg™ electronic work under this agreement, disclaim all liability to you for damages, costs and expenses,

including legal fees. YOU AGREE THAT YOU HAVE NO REMEDIES FOR NEGLIGENCE, STRICT LIABILITY, BREACH OF WARRANTY OR BREACH OF CONTRACT EXCEPT THOSE PROVIDED IN PARAGRAPH 1.F.3. YOU AGREE THAT THE FOUNDATION, THE TRADEMARK OWNER, AND ANY DISTRIBUTOR UNDER THIS AGREEMENT WILL NOT BE LIABLE TO YOU FOR ACTUAL, DIRECT, INDIRECT, CONSEQUENTIAL, PUNITIVE OR INCIDENTAL DAMAGES EVEN IF YOU GIVE NOTICE OF THE POSSIBILITY OF SUCH DAMAGE.

1.F.3. LIMITED RIGHT OF REPLACEMENT OR REFUND - If you discover a defect in this electronic work within 90 days of receiving it, you can receive a refund of the money (if any) you paid for it by sending a written explanation to the person you received the work from. If you received the work on a physical medium, you must return the medium with your written explanation. The person or entity that provided you with the defective work may elect to provide a replacement copy in lieu of a refund. If you received the work electronically, the person or entity providing it to you may choose to give you a second opportunity to receive the work electronically in lieu of a refund. If the second copy is also defective, you may demand a refund in writing without further opportunities to fix the problem.

1.F.4. Except for the limited right of replacement or refund set forth in paragraph 1.F.3, this work is provided to you 'AS-IS', WITH NO OTHER WARRANTIES OF ANY KIND, EXPRESS OR IMPLIED, INCLUDING BUT NOT LIMITED TO WARRANTIES OF MERCHANTABILITY OR FITNESS FOR ANY PURPOSE.

1.F.5. Some states do not allow disclaimers of certain implied warranties or the exclusion or limitation of certain types of damages. If any disclaimer or limitation set forth in this agreement violates the law of the state applicable to this agreement, the agreement shall be interpreted to make the maximum disclaimer or limitation permitted by the applicable state law. The invalidity or unenforceability of any provision of this agreement shall not void the remaining provisions.

1.F.6. INDEMNITY - You agree to indemnify and hold the Foundation, the trademark owner, any agent or employee of the Foundation, anyone providing copies of Project Gutenberg™ electronic works in accordance with this agreement, and any volunteers associated with the production, promotion and distribution of Project Gutenberg™ electronic works, harmless from all liability, costs and expenses, including legal fees, that arise directly or indirectly from any of the following which you do or cause to occur: (a) distribution of this or any Project Gutenberg™ work, (b) alteration, modification, or additions or deletions to any Project Gutenberg™ work, and (c) any Defect you cause.

Section 2. Information about the Mission of Project Gutenberg™

Project Gutenberg™ is synonymous with the free distribution of electronic works in formats readable by the widest variety of computers including obsolete, old, middle-aged and new computers. It exists because of the efforts of hundreds of volunteers and donations from people in all walks of life.

Volunteers and financial support to provide volunteers with the assistance they need are critical to reaching Project Gutenberg™'s goals and ensuring that the Project Gutenberg™ collection will remain freely available for generations to come. In 2001, the Project Gutenberg Literary Archive Foundation was created to provide a secure and permanent future for Project Gutenberg™ and future generations. To learn more about the Project Gutenberg Literary Archive Foundation and how your efforts and donations can help, see Sections 3 and 4 and the Foundation information page at www.gutenberg.org.

Section 3. Information about the Project Gutenberg Literary Archive Foundation

The Project Gutenberg Literary Archive Foundation is a non-profit 501(c)(3) educational corporation organized under the laws of the state of Mississippi and granted tax exempt status by the Internal Revenue Service. The Foundation's EIN or federal tax identification number is 64-6221541. Contributions to the Project Gutenberg Literary Archive Foundation are tax deductible to the full extent permitted by U.S. federal laws and your state's laws.

The Foundation's business office is located at 809 North 1500 West, Salt Lake City, UT 84116, (801) 596-1887. Email contact links and up to date contact information can be found at the Foundation's website and official page at www.gutenberg.org/contact

Section 4. Information about Donations to the Project Gutenberg Literary Archive Foundation

Project Gutenberg™ depends upon and cannot survive without widespread public support and donations to carry out its mission of increasing the number of public domain and licensed works that can be freely distributed in machine-readable form accessible by the widest array of equipment including outdated equipment. Many small donations (\$1 to \$5,000) are particularly important to maintaining tax exempt status with the IRS.

The Foundation is committed to complying with the laws regulating charities and charitable donations in all 50 states of the United States. Compliance requirements are not uniform and it takes a considerable effort, much paperwork and many fees to meet and keep up with these requirements. We do not solicit donations in locations where we have not received written confirmation of compliance. To SEND DONATIONS or determine the status of compliance for any particular state visit www.gutenberg.org/donate.

While we cannot and do not solicit contributions from states where we have not met the solicitation requirements, we know of no prohibition against accepting unsolicited donations from donors in such states who approach us with offers to donate.

International donations are gratefully accepted, but we cannot make any statements concerning tax treatment of donations received from outside the United States. U.S. laws alone swamp our small staff.

Please check the Project Gutenberg web pages for current donation methods and addresses. Donations are accepted in a number of other ways including checks, online payments and credit card donations. To donate, please visit: www.gutenberg.org/donate

Section 5. General Information About Project Gutenberg™ electronic works

Professor Michael S. Hart was the originator of the Project Gutenberg™ concept of a library of electronic works that could be freely shared with anyone. For forty years, he produced and distributed Project Gutenberg™ eBooks with only a loose network of volunteer support.

Project Gutenberg™ eBooks are often created from several printed editions, all of which are confirmed as not protected by copyright in the U.S. unless a copyright notice is included. Thus, we do not necessarily keep eBooks in compliance with any particular paper edition.

Most people start at our website which has the main PG search facility: www.gutenberg.org.

This website includes information about Project Gutenberg™, including how to make donations to the Project Gutenberg Literary Archive Foundation, how to help produce our new eBooks, and how to subscribe to our email newsletter to hear about new eBooks.