

**The Project Gutenberg eBook of Scientific American Supplement,  
No. 312, December 24, 1881, by Various**

This ebook is for the use of anyone anywhere in the United States and most other parts of the world at no cost and with almost no restrictions whatsoever. You may copy it, give it away or re-use it under the terms of the Project Gutenberg License included with this ebook or online at [www.gutenberg.org](http://www.gutenberg.org). If you are not located in the United States, you'll have to check the laws of the country where you are located before using this eBook.

Title: Scientific American Supplement, No. 312, December 24, 1881

Author: Various

Release date: February 22, 2006 [EBook #17817]

Language: English

Credits: Produced by Juliet Sutherland and the Online Distributed Proofreading Team at [www.pgdp.net](http://www.pgdp.net)

\*\*\* START OF THE PROJECT GUTENBERG EBOOK SCIENTIFIC AMERICAN  
SUPPLEMENT, NO. 312, DECEMBER 24, 1881 \*\*\*



Scientific American Supplement Vol. XII. No. 312.  
Scientific American, established 1845.

NEW YORK, DECEMBER 24, 1881.

Scientific American Supplement, \$5 a year.  
Scientific American and Supplement, \$7 a year.

**SCIENTIFIC AMERICAN  
SUPPLEMENT NO. 312**

**NEW YORK, DECEMBER 24, 1881**

**Scientific American Supplement. Vol. XII., No. 312.**

**Scientific American established 1845**

**Scientific American Supplement, \$5 a year.**

**Scientific American and Supplement, \$7 a year.**

**TABLE OF CONTENTS.**

	PAGE.
I. <a href="#">ENGINEERING AND MECHANICS.—Improved Fifteen Ton Traveling Crane. Designed for service in the construction of Port Alfred Harbor. South Africa. 3 figures.</a>	4967
<a href="#">Improved Steam Boiler. 1 figure.</a>	4968
<a href="#">The Elevated Railways of New York.</a>	4968
<a href="#">Some of the Developments of Mechanical Engineering during the Last Half Century. British Association Paper. By SIR FREDERICK BRAMWELL. The steam engine.—Evaporative condenser.—Steam navigation.—Marine governors.—Light engines and boilers.—The Perkins system.—Ether engine.—Quicksilver engine.—Locomotive engines.—Brakes.—Motors.—Transmission of power.—Compressed air locomotives.—Hydraulic transmission of power.—Electric transmission of power.—The manufacture of iron and steel.—Bridges.—Machine tools.—The sewing machine.—Agricultural machinery.—Printing machinery.</a>	4968

	<a href="#">Amateur Mechanics: Metal turning, 29 figures. Rotary cutters, 12 figures. Wood-working and lathe attachments, 9 figures.</a>	4971
	<a href="#">A New Method of Keeping Mechanical Drawings.</a>	4978
	<a href="#">Achard's Electric Brake for Railway Use. 2 figures. Plan and elevation.</a>	4974
II.	<a href="#">ELECTRICITY, ETC.—Electricity. What it is and what may be expected of it. By JACOB REESE.</a>	4974
	<a href="#">Electric Light Apparatus for Photographic Purposes. By A.J. JARMAN. 2 figures.</a>	4976
	<a href="#">Desruelles's Electric Lighter. 1 figure.</a>	4976
	<a href="#">Solenoid Underground Wires in Philadelphia.</a>	4976
	<a href="#">Dr. Herz's Telephonic Systems. 2 figures.</a>	4976
	<a href="#">Decision of the Congress of Electricians on the Units of Electric Measures.</a>	4977
	<a href="#">Secondary Batteries. By J. ROUSSE.</a>	4977
III.	<a href="#">TECHNOLOGY AND CHEMISTRY.—Domestic Sugar Production.</a>	4980
	<a href="#">M. Garnier's New Methods of Photo-Engraving. By Major J. WATERHOUSE.—Photogravure.—Photograph printing by vapor.—Atmography.</a>	4982
	<a href="#">Dangers of Pyrogallic Acid. By DR. T.L. PHIPSON.</a>	4982
IV.	<a href="#">ARCHITECTURE, ETC.—Artists' Homes, No. 12.—Wm. Emerson's house, Little Sutton, Chiswick.—Full page illustration and large size longitudinal section.</a>	4978
	<a href="#">Memorable English Houses. 4 figures.—Newton's house.—Flaxman's house.—Canning's house.—Johnson's house.</a>	4980
V.	<a href="#">GEOGRAPHY.—Herald Island.—On the summit.—A midnight observation.—Plant life on Herald Island.—Inhabitants of the cliffs.</a>	4980
VI.	<a href="#">METALLURGY.—The Treatment of Quicksilver Ores in Spain.</a>	4977
VII.	<a href="#">AERONAUTICS.—The Balloon in Aeronautics.</a>	4977
VIII.	<a href="#">BIOGRAPHY.—Franz Liszt.—Large Portrait.</a>	4981

## IMPROVED FIFTEEN TON CRANE.

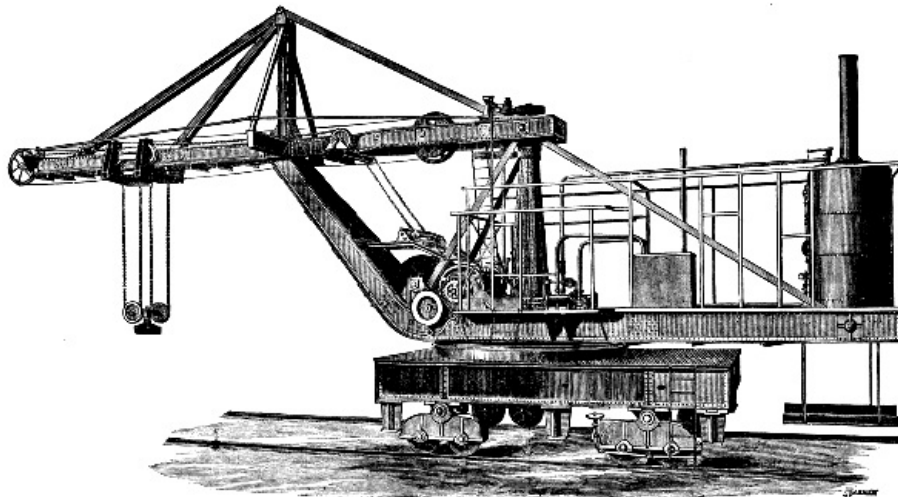

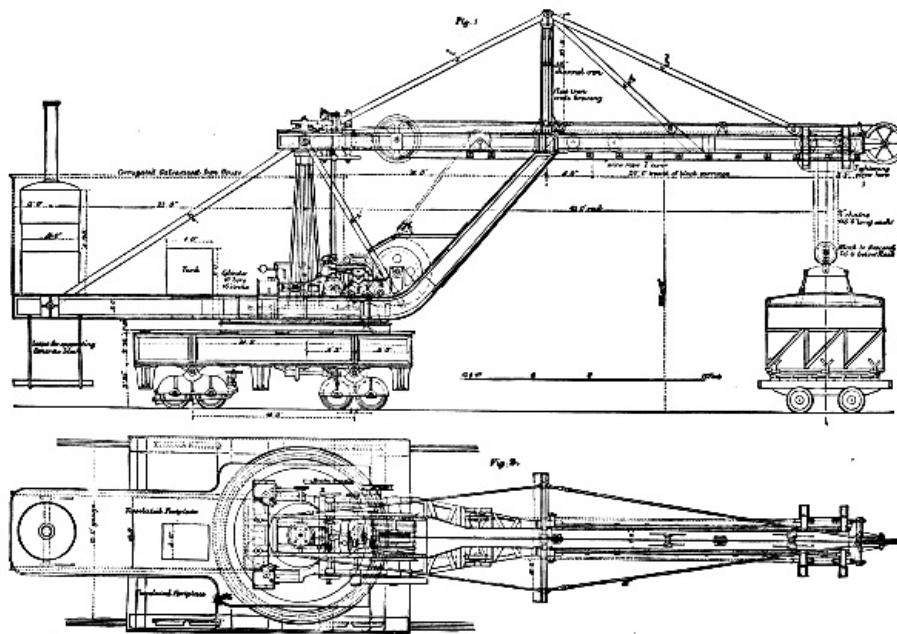

### IMPROVED FIFTEEN TON TRAVELING CRANE.

The machine illustrated on first page has been constructed for Port Alfred Harbor, this being one of several harbors now being made by Sir J. Coode in South Africa. The pier for the construction of which the crane will be employed will consist of concrete blocks laid on what is known as the "overend system." The blocks, being brought on trucks direct from the block yard to within the sweep of the machine, are raised by it, swung round, and accurately set, the machine being continually traveled forward as the work advances. The bottom blocks are laid on bags of concrete previously deposited by the crane out of boxes with flap bottoms.

The present machine has been specially designed throughout, and represents the most complete development which block-setting plant has yet attained.

The most striking features of the crane are, the great range of all the motions, the large radius, and the method of providing for the latter by a horizontal jib suspended from a king-post. It was at first intended to have a straight inclined jib, and to alter the radius by pivoting this round its lower end, as is commonly done; it occurred, however, to Mr. Matthews, M.I.C.E., representing Sir J. Coode, that the plan eventually adopted would be in many ways preferable; the crane was therefore constructed by Messrs. Stothert & Pitt with this modification, and as far as can be judged from the trial with proof load, the arrangements can hardly be surpassed for quick and accurate block-setting. In cranes with "derricking" jibs it is necessary to connect the derrick and hoisting gears in such a manner that a variation of the radius may not affect the level of the load; this plan answers sufficiently well for ordinary purposes, but for block-setting it is requisite to have extreme accuracy in all the movements and great quickness in changing from one to another; the arrangements adopted in foundry cranes, in which all the motions are entirely independent of one another, seems therefore more suited for this kind of work. Other not inconsiderable advantages are also secured by the adoption of the foundry crane type, the amount of clear headway under the jib being much increased, and the difficulty avoided of making a jib sixty feet long sufficiently stiff without undue weight.

The principal dimensions of the crane are, total height of lift 46 feet, radius variable from 25 feet minimum to 45 feet maximum, height from rail to underside of jib 22 feet 2¾ inches, radius of tail to center of boiler 22 feet, working load 15 tons, proof load 19 tons.

The general arrangement consists of a truck on which is fixed a post, round which the crane revolves; the jib is supported midway by an inclined strut, above which is placed the king-post; the strut is curved round at the bottom and forms one piece with the side frames, which are carried right back as a tail to support the boiler and balance weight.

The hoisting gear consists of a double system of chains 13/16 in. in diameter placed side by side; each chain is anchored by an adjustable screw to the end of the jib, and, passing round the traveling carriage and down to the falling block, is taken along the jib over a sliding pulley which leads it on to the grooved barrel, 3 ft. 9 in. in diameter. In front of the barrel is placed an automatic winder which insures a proper coiling of the chain in the grooves. The motive power is derived from two cylinders 10 in. in diameter and 16 in. stroke, one being bolted to each side frame; these cylinders, which are provided with link motion and reversing gear, drive a steel crank shaft 2¾ in. in diameter; on this shaft is a steel sliding pinion which drives the barrel by a

double purchase.

In the center of the crank-shaft is a large reversing friction clutch, which drives, through miter gear, a vertical shaft placed just in front of the post; from the latter the slewing, racking, and traveling motions are obtained.

The crane can be turned through a complete circle by a pinion gearing into a machine-moulded toothed ring bolted to the top of the truck; this ring is 11 ft. 4-7/8 in. in diameter, and contains 172 teeth 2½ in pitch. The slewing pinion is driven by intermediate gearing from the bottom of the vertical shaft mentioned above. For the turning motion two distinct sets of rollers are provided; these are carried by cross-girders placed between the side frames; one set runs against a cast-iron roller path bolted round the bottom of the post, and the other on the large horizontal roller path seen in the engraving. The latter is 14 ft. in diameter; it is built up of two deep curved channel irons with top and bottom plates forming a circular box girder, on the top of which a heavy flat rail is riveted, and the whole turned up in the lathe. The racking and traveling motions are driven from the top end of the vertical shaft; the racking gear consists of wire ropes attached to each side of the traveling carriage and coiled round a large barrel, the outer rope being brought over a pulley at the end of the jib. The rails for the carriage rest on rolled joints bolted to the underside of jib. This arrangement involves the use of an overhung traveling carriage, but enables the jib to be of a stiff box section, the side stiffness being further secured by wind ties.

The traveling motion is worked by a second vertical shaft, which passes down the center of the post, and by means of a cross shaft is geared to the front axle, from which four of the ground wheels are driven.

The post is octagonal, built up of plates ¾ in. thick; at the bottom end it is secured to the girders of the truck, and at the top is shrunk on to a large gudgeon 12 in. in diameter, which enters a casting fixed in the back end of the jib; on the top of the gudgeon are two steel disks on which an adjustable cap rests; by means of this and the ties to the tail and the lower end of the strut a proportion of the weight can be brought on to the post so as to relieve the roller path to any desired extent, and enable the crane to be revolved easily.

The truck is 24 ft. long and 16 ft. 4½ in. wide; it is constructed of longitudinal and transverse box girders 2 ft. 8 in. deep, and rests on two axles 6 in. in diameter; round these axles swivel the cast-iron bogie frames which carry the ground wheels. This arrangement was adopted because the crane has to travel up a gradient of 1 in 30, and the bogies enable it to take the incline better; they also distribute the weight more evenly on the wheels. The gauge of the rails is 15 ft, the wheels are 2 ft. 6 in. in diameter, and have heavy steel tires. The weight on each of the front wheels when running with the ballast, but no load, is about 16 tons. A powerful brake is applied to the wheels when descending the incline.

All the clutch levers, break treadle, and handles are brought together, so that one man has the crane under his entire control. An iron house, of which the framing only is shown, extends from the gearing right back to the boiler, forming a most spacious engine room and stokehole. A separate donkey engine is provided for feeding the boiler. The truck is furnished with legs under which packings can be wedged so as to relieve the load on the wheels when block-setting. The slings seen under the boiler are for hanging a concrete balance weight; this will weigh about 20 tons. The weight of the crane itself without load or ballast is about 80 tons. The crane was tested under steam with a load of 19 tons with the most satisfactory results; the whole machine appeared to be very rigid, an end often very difficult to obtain with portable wrought-iron structures and live loads. The result in the present case is probably greatly due to the careful workmanship, and to the fact that the sides and ends of the plates are planed throughout, so that the webs of the girders get a fair bearing on the top and bottom plates.

The crane showed itself to be very handy and quick in working, the speeds with 19 tons load, as actually timed at the trial, are: lifting 16 ft. per minute, racking motion 46 ft. per minute, slewing through a complete circle 90 ft. diameter, four minutes, equivalent to a speed at load of 60 ft. per minute. The crane was constructed by Messrs. Stothert & Pitt, of Bath, to the order of the Crown agents for the colonies, and we understand that the design and construction have given complete satisfaction to Sir J. Coode, the engineer to the harbor works, under whose supervision the crane was constructed.—*Engineering*.

---

## IMPROVED STEAM-BOILER.

An improvement in steam-boilers, best understood by reference to the ordinary vertical form, has been introduced by Mr. T. Moy, London. Here the flue is central, and, as shown in the accompanying illustration, is crossed by a number of horizontal

water-tubes at different heights. The ends of these tubes are embraced, within the steam chamber, by annular troughs. At the top domed part of the boiler are two annular chambers, the outer one being intended to receive the water upon entry from the feed-pump, and to contain any sedimentary deposit which may be formed. The water next passes, by the pipe, *a*, in the figure, into the inner chamber, surrounding the end of the uptake flue, whence it flows through the pipe, *b*, down into the first of the annular troughs above mentioned, and afterward overflows these troughs in succession until it reaches the bottom. Mr. Moy claims to have secured by this means a boiler of quick steaming capacity, together with a reduction in the weight of metal, and considerable economy of fuel. By the arrangement of the water in a number of shallow layers a large steaming surface is obtained, and there is a good steam space rendered available round the troughs. The water also enters at a point where it may abstract as much heat as possible from the furnace gases before they escape; and by the separation of the top domed chamber from the rest of the boiler the operation of scaling and cleaning is facilitated. The arrangement is also adapted to horizontal and multitubular boilers, to be fired with solid, liquid, or gaseous fuel.

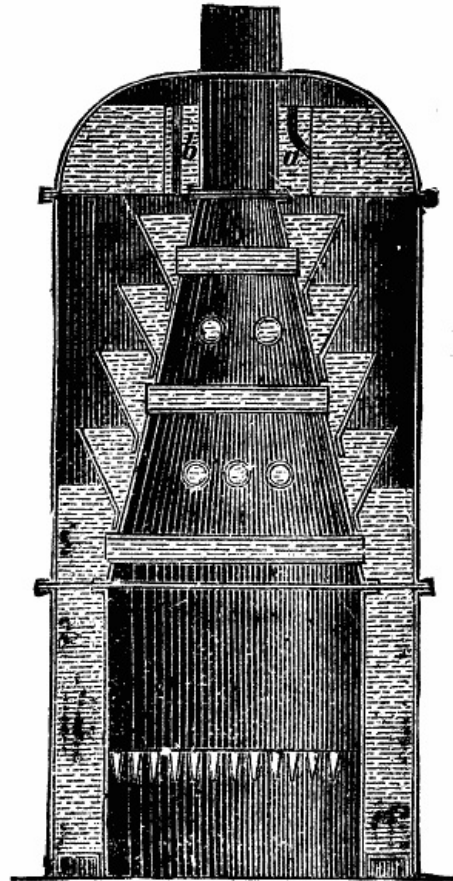

**IMPROVED BOILER.**

---

## **THE ELEVATED RAILWAYS OF NEW YORK.**

But few persons who have not been in New York since the construction of the elevated roads, and witnessed their equipments and operations, can have any adequate idea of the extent of them, and of the people, machinery, and appurtenances required in working them. A recent inventory discloses the fact that there are 32 miles of roadway, 161 stations, 203 engines, and 612 cars, while 3,480 trains a day are run. There are 3,274 men employed on these roads, 309 of whom are engineers, 258 ticket agents, 231 conductors, 308 firemen, 395 guards or brakemen, 347 gatemen, 4 road inspectors, 106 porters, 33 carpenters, 27 painters, 69 car inspectors, 140 car cleaners, 40 lamp men, and 470 blacksmiths, boiler makers, and other mechanics employed on the structure and in the shops. Most of the ticket agents are telegraph operators, but there are 13 other operators employed. There are four double-track lines in operation. The aggregate daily receipts vary from \$14,000 to \$18,000; and as many as 274,023 passengers have been carried in one day. Engineers are paid from \$3 to \$3.50 per day; ticket agents, \$1.75 to \$2.25; conductors, \$1.90 to \$2.50; firemen, \$1.90 to \$2; guards or brakemen, \$1.50 to \$1.65; and gatemen, \$1.20 to \$1.50. The above items do not include machinists and other *employés* in the workshops, or the general officers, clerks, etc.

A Baltimore dispatch informs us that a carload of antimony, ten tons in all, was lately received by C.L. Oudesluys & Co., from the southern part of Utah Territory, being the first antimony received in the East from the mines of that section. The antimony was mined about 140 miles from Salt Lake City. The ore is a sulphide, bluish gray in color, and yields from 60 to 65 per cent. of antimony. All antimony heretofore came from Great Britain and the island of Borneo, and paid an import duty of 10 per cent. ad valorem, and there is also some from Sonora. It is believed that with proper rail facilities to the mines of the West there will be no need of importations.

---

## **SOME OF THE DEVELOPMENTS OF MECHANICAL ENGINEERING DURING THE LAST HALF- CENTURY.<sup>1</sup>**

**By SIR FREDERICK BRAMWELL, V.P. Inst. C.E., F.R.S.,  
Chairman of the Council of the Society of Arts.**

I am quite sure the section will agree with me in thinking it was very fortunate for us, and for science generally, that our president refrained from occupying the time of the section by a retrospect, and devoted himself, in that lucid and clear address with which he favored us, to the consideration of certain scientific matters connected with engineering, and to the foreshadowing of the directions in which he believes it possible that further improvements may be sought for. But I think it is desirable that some one should give to this section a record, even although it must be but a brief and an imperfect one, of certain of the improvements that have been made, and of some of the progress that has taken place, during the last fifty years, in the practical application of mechanical science, with which science and its applications our section is particularly connected. I regret to say that, like most of the gentlemen who sat on this platform yesterday, who, I think, were, without exception, past presidents of the section, I am old enough to give this record from personal experience. Fifty years ago I had not the honor of being a member, nor should I, it is true, have been eligible for membership of the association; but I was at that time vigorously making models of steam-engines, to the great annoyance of the household in which I lived, and was looking forward to the day when I should be old enough to be apprenticed to an engineer. Without further preface, I will briefly allude to some of the principal developments of a few of the branches of engineering. I am well aware that many branches will be left unnoticed; but I trust that the omissions I may make will be remedied by those present who may speak upon the subject after me.

I will begin by alluding to

### **THE STEAM-ENGINE EMPLOYED FOR MANUFACTURING PURPOSES.**

In 1831, the steam-engine for these purposes was commonly the condensing beam engine, and was supplied with steam from boilers, known, from their shape, as wagon boilers; this shape appears to have been chosen rather for the convenience of the sweeps, who periodically went through the flues to remove the soot consequent on the imperfect combustion, than for the purpose of withstanding any internal pressure of steam. The necessary consequence was, that the manufacturing engines of those days were compelled to work with steam of from only 3½ lb. to 5 lb. per square inch of pressure above atmosphere. The piston speed rarely exceeded 250 feet per minute, and as a result of the feeble pressure, and of the low rate of speed, very large cylinders indeed were needed relatively to the power obtained. The consumption of fuel was heavy, being commonly from 7 lb. to 10 lb. per gross indicated horsepower per hour. The governing of the engine was done by pendulum governors, revolving slowly, and not calculated to exert any greater effort than that of raising the balls at the end of the pendulum arms, thus being, as will be readily seen, very inefficient regulators. The connection of the parts of the engine between themselves was derived from the foundation upon which the engine was supported. Incident to the low piston speed was slowness of revolution, rendering necessary heavy fly wheels, to obtain even an approach to practical uniformity of rotation, and frequently rendering necessary also heavy trains of toothed gearing, to bring up the speed from that of the revolutions of the engine to that of the machinery it was intended to drive.

In 1881, the boilers are almost invariably cylindrical, and are very commonly internally fired, either by one flue or by two; we owe it to the late Sir William Fairbairn, President of the British Association in 1861, that the danger, which at one time existed, of the collapse of these fire flues, has been entirely removed by his application of circumferential bands. Nowadays there are, as we know, modifications of Sir William Fairbairn's bands, but by means of his bands, or by modifications

thereof, all internally flued boilers are so strengthened that the risk of a collapse of the flue is at an end. Boilers of this kind are well calculated to furnish—and commonly do furnish—steam of from 40 lb. to 80 lb. pressure above atmosphere.

The piston speed is now very generally 400 feet or more, so that, notwithstanding that there is usually a liberal expansion, the mean pressure upon the piston is increased, and this, coupled with its increased speed, enables much more power to be obtained from a given size of cylinder than was formerly obtainable. The revolutions of the engine now are as many as from 60 to 200 per minute, and thus, with far lighter fly-wheels, uniformity of rotation is much more nearly attained.

### **THE EVAPORATIVE CONDENSER.**

Moreover, all the parts of the engine are self-contained; they no longer depend upon the foundation, and in many cases the condensing is effected either by surface condensers, or, where there is not sufficient water, the condensation is, in a few instances, effected by the evaporative condenser—a condenser which, I am sorry to say, is not generally known, and is therefore but seldom used, although its existence has been nearly as long as that of the association. Notwithstanding the length of time during which the evaporative condenser has been known to some engineers, it is a common thing to hear persons say, when you ask them if they are using a condensing engine, "I can not use it; I have not water enough." A very sufficient answer indeed, if an injection condenser or an ordinary surface condenser constituted the sole means by which a vacuous condition might be obtained; but a very insufficient answer, having regard to the existence of the evaporative condenser, as by its means, whenever there is water enough for the feed of a non condensing engine, there is enough to condense, and to produce a good vacuum.

The evaporative condenser simply consists of a series of pipes, in which is the steam to be condensed, and over which the water is allowed to fall in a continuous rain. By this arrangement there is evaporated from the outside of the condenser a weight of water which goes away in a cloud of vapor, and is nearly equal to that which is condensed, and is returned as feed into the boiler. The same water is pumped up and used outside the condenser, over and over, needing no more to supply the waste than would be needed as feed water. Although this condenser has, as I have said, been in use for thirty or forty years, one still sees engines working without condensation at all, or with waterworks water, purchased at a great cost, and to the detriment of other consumers who want it for ordinary domestic purposes; or one sees large condensing ponds made, in which the injection water is stored to be used over and over again, and frequently (especially toward the end of the week) in so tepid a state as to be unfit for its purpose. The governing is now done by means of quick-running governors, which have power enough in them to raise not merely the weight of the pendulum ball, which is now small, but a very heavy weight, and in this way the governing is extremely effective. I propose to say no more, looking at the magnitude of the whole of my subject, upon the engine used for manufacturing purposes, but rather to turn at once to those employed for other objects.

### **STEAM NAVIGATION.**

In 1831, there were a considerable number of paddle steamers running along some of the rivers in England, and across the Channel to the Continent. But there were no ocean steamers, properly so-called, and there were no steamers used for warlike purposes. As in the case of the wagon boilers, the boilers of the paddle steamers of 1831 were most unsuited for resisting pressure. They were mere tanks, and there was as much pressure when there was no steam in the boiler from the weight of the water on the bottom, as there was at the top of the boiler from the steam pressure when the steam was up. Under these circumstances, again, from 3½ lb. to 5 lb. was all the pressure the boilers were competent to bear, and as the engines ran at a slow speed, they developed but a small amount of horse-power in relation to their size. Moreover, as in the land engine, the connection between the parts of the marine engine was such as to be incompetent to stand the strain that would come upon it if a higher pressure, with a considerable expansion, were used, and thus the consumption of coal was very heavy; and we know that, having regard to the then consumption, it was said, on high authority, it would be impossible for a steamboat to traverse the Atlantic, as it could not carry fuel enough to take it across; and indeed it was not until 1838 that the *Sirius* and the *Great Western* did make the passage. The passage had been made before, but it was not until 1838 that the passenger service can be said to have commenced. In 1831, the marine boiler was supplied with salt water, the hulls were invariably of wood, and the speed was probably from eight to nine knots an hour. In 1881, the vessels are as invariably either of iron or of steel, and I believe it will not be very long before the iron disappears, giving place entirely to the last mentioned metal. With respect to the term "steel," I am ready to agree that it is impossible to say where, chemically speaking, iron ends and steel begins. But (leaving out malleable cast iron) I apply this term "steel" to any malleable ductile metal of which iron forms the principal element and which has been in fusion, and I

do so in contradistinction to the metal which may be similar chemically, but which has been prepared by the puddling process. Applying the term steel in that sense, I believe, as I have said, it will not be very long before plate-iron produced by the puddling process will cease to be used for the purpose of building vessels. With respect to marine engines, they are now supplied with steam from multiple tubed boilers, the shells of which are commonly cylindrical. They are of enormous strength, and made with every possible care, and carry from 80 lb. to 100 lb. pressure on the square inch.

It has been found, on the whole, more convenient to expand the steam in two or more cylinders, rather than in one. I quite agree that, as a mere matter of engineering science, there is no reason why the expansion should not take place in a single cylinder, unless it be that a single cylinder is cooled down to an extent which cannot be overcome by jacketing, and which, therefore, destroys a portion of the steam on its entering into the cylinder.

As regards the propeller, as we know, except in certain cases, the paddle-wheel has practically disappeared, and the screw propeller is all but universally employed. The substitution of the screw propeller for the paddle enables the engine to work at a much higher number of revolutions per minute, and thus a very great piston speed, some 600 ft. to 800 ft. per minute, is attained; and this, coupled with the fairly high mean pressure which prevails, enables a large power to be got from a comparatively small-sized engine. Speeds of 15 knots an hour are now in many cases maintained, and on trial trips are not uncommonly exceeded. Steam vessels are now the accepted vessels of war. We have them in an armored state and in an unarmored state, but when unarmored rendered so formidable, by the command which their speed gives them of choosing their distance, as to make them, when furnished with powerful guns, dangerous opponents even to the best armored vessels.

### **MARINE GOVERNORS.**

We have also now marine engines, governed by governors of such extreme sensitiveness as to give them the semblance of being endowed with the spirit of prophecy, as they appear rather to be regulating the engine for that which is about to take place than for that which is taking place. This may sound a somewhat extravagant statement, but it is so nearly the truth, that I have hardly gone outside of it in using the words I have employed. For a marine governor to be of any use, it must not wait till the stern of the vessel is out of the water before it acts to check the engine and reduce the speed. Nothing but the most sensitive, and, indeed, anticipatory action of the governors can efficiently control marine propulsion. Instances are on record of vessels having engines without marine governors being detained by stress of weather at the mouth of the Thames, while vessels having such governors, of good design, have gone to Newcastle, have come back, and have found the other vessels still waiting for more favorable weather.

With respect to condensation in marine engines, it is almost invariably effected by surface condensers, and thus it is that the boilers, instead of being fed with salt water as they used to be, involving continuous blowing off, and frequently the salting up, of the boiler, are now fed with distilled water. It should be noticed, however, that in some instances, owing to the absence of a thin protecting scale upon the tubes and plates, very considerable corrosion has taken place when distilled water, derived from condensers having untinned brass tubes, has been used, and where the water has carried into the boiler fatty acids, arising from the decomposition of the grease used in the engine; but means are now employed by which these effects are counteracted.

### **LIGHT ENGINES AND BOILERS.**

I wish, before quitting this section of my subject, to call your attention to two very interesting but very different kinds of marine engines. One is the high-speed torpedo vessel, or steam launch, of which Messrs. Thornycroft's firm have furnished so many examples. In these, owing to the rate at which the piston runs to the initial pressure of 120 lb. and to very great skill in the design, Messrs. Thornycroft have succeeded in obtaining a gross indicated horse-power for as small a weight as half a cwt., including the boiler, the water in the boiler, the engine, the propeller shaft, and the propeller itself.

To obtain the needed steam from the small and light boiler, recourse has to be made to the aid of a fan blast driven into the stoke-hole. From the use of a blast in this way advantages accrue. One is, as already stated, that from a small boiler a large amount of steam is produced. Another is that the stoke-hole is kept cool; and the third is that artificial blasts thus applied are unaccompanied by the dangers which arise, when under ordinary circumstances the blast is supplied only to the ash-pit itself.

### **THE PERKINS SYSTEM.**



The second marine engine to which I wish to call your attention is one that has been made with a view to great economy. The principles followed in its construction are among those suggested by the President (Sir W.G. Armstrong) in his address. He (you will remember) pointed out that the direction in which economy in the steam engine was to be looked for was that of increasing the initial pressure; although at the same time he said that there were drawbacks in the shape of greater loss, by radiation, and by the higher temperature at which the products of combustion will escape. We must admit the fact of the latter source of loss, when using very high steam, it being inevitable that temperature of the products of combustion escaping from a boiler under these conditions must be higher than those which need be allowed to escape when lower steam is employed; although I regret to say that in practice in marine boilers working at comparatively low pressures the products are ordinarily suffered to pass into the funnel at above the temperature of melted lead. But with respect to the loss by radiation in the particular engine I am about to mention—that of Perkins—there is not as much loss as that which prevails in the ordinary marine boilers, because the Perkins boiler is completely inclosed, with the result that while there is within the case a boiler containing steam of 400 lb. on the square inch, and the fire to generate that steam, the hand may be applied to the casting itself, which contains the whole of the boiler, without receiving any unpleasant sensation of warmth. By Mr. Perkins's arrangement, using steam of 400 lb. in the boiler, it was found, as the result of very severe trials, conducted by Mr. Rich, of Messrs. Easton and Anderson's firm, and myself—trials which lasted for twelve hours—that the total consumption of fuel, including that for getting up steam from cold water, was just under 1.8, actually 1.79 lb. per gross indicated horse-power per hour. That gross indicated horse-power was obtained in a manner which it is desirable should always be employed in steamboat trials. It was not got by using as a divisor the horse-power of the most favorable diagram obtained during the day; but it was got from diagrams taken during the regular work; then, every half-hour, when the pressure began to die down, from coal being no longer put upon the fire, diagrams taken every quarter of an hour, and then toward the last, every five minutes; and the total number of foot pounds were calculated from these diagrams, and were used to obtain the gross indicated horse-power.

Further, so far as could be ascertained by the process of commencing a trial with a known fire, and closing that trial at the end of six hours, with the fire as nearly as possible in the same condition, the consumption was 1.66 lb. of coal per gross indicated horse-power per hour. So that, without taking into account the coal consumed in raising steam from cold water, the engine worked for 1-2/3 lb. of coal per horse per hour. I think it well to give these details, because undoubtedly it is an extremely economical result.

### **ETHER ENGINE.**

Our president alluded to the employment of ether as a means of utilizing the heat which escaped into the condenser, and gave some account of what was done by Mons. Du Tremblay in this direction. It so happened that I had occasion to investigate the matter at the time of Du Tremblay's experiments; very little was effected here in England, one difficulty being the excise interference with the manufacture of ether. Chloroform was used here, and it was also suggested to employ bisulphide of carbon. In France, however, a great deal was done. Four large vessels were fitted with the ether engines, and I went over to Marseilles to see them at work. I took diagrams from these engines, and there is no doubt that, by this system, the exhaust steam from the steam cylinder, which was condensed by the application of ether to the surface of the steam condenser (producing a respectable vacuum of about 22 inches), gave an ether pressure of 15 lb. on the square inch above atmosphere, and very economical results as regards fuel were obtained. The scheme was, however, abandoned from practical difficulties. It need hardly be said that ether vapor is very difficult to deal with, and although ether is light, the vapor is extremely heavy, and if there is any leakage, it goes down into the bilges by gravitation, and being mixed with air, unless due care is taken to prevent access to the flues, there would be a constant risk of a violent explosion. In fact, it was necessary to treat the engine room in the way in which a fiery colliery would be treated. The lighting, for instance, was by lamps external to the engine room, and shining through thick plate-glass. The hand lamps were Davy's. The ether engine was a bold experiment in applied science, and one that entitles Du Tremblay's name to be preserved, and to be mentioned as it was by our president.

### **THE QUICKSILVER ENGINE.**

These was another kind of marine engine that I think should not be passed over without notice; I allude to Howard's quicksilver engine. The experiments with this engine were persevered in for some considerable time, and it was actually used for practical purposes in propelling a passenger steam-vessel called the Vesta, and running between London and Ramsgate. In that engine the boiler had a double

bottom, containing an amalgam of quicksilver and lead. This amalgam served as a reservoir of heat, which it took up from the fire below the double-bottom, and gave forth at intervals to the water above it. There was no water in the boiler, in the ordinary sense of the term, but when steam was wanted to start the engine, a small quantity of water was injected by means of a hand-pump, and after the engine was started, there was pumped by it into the boiler, at each half revolution, as much water as would make the steam needed. This water was flashed on the top surface of the reservoir in which the amalgam was confined, and was entirely turned into steam, the object of the engineers in charge being to send in so much water as would just generate the steam, but so as not to leave any water in the boiler. The engines of the *Vesta* were made by Mr. Penn, for Mr. Howard, of the King and Queen Ironworks, Rotherhithe. Mr. Howard was, I fear, a considerable loser by his meritorious efforts to improve the steam-engine.

There was used, with this engine, an almost unknown mode of obtaining fresh water for the boiler. Fresh water, it will be seen was a necessity in this mode of evaporation. The presence of salt, or of any other impurity, when the whole of the water was flashed into steam, must have caused a deposit on the top of the amalgam chamber at each operation. Fresh water, therefore, was needed; the problem arose how to get it; and that problem was solved, not by the use of surface condensation, but by the employment of reinjection, that is to say, the water delivered from the hot well was passed into pipes external to the vessel; after traversing them, it came back into the injection tank sufficiently cooled to be used again. The boilers were worked by coke fires, urged by a fan blast in their ashpits, but I am not aware that this mode of firing was a needful part of the system.

### **LOCOMOTIVE ENGINES.**

I come now to the engines used for railways. At the British Association meeting of 1831, the Manchester and Liverpool Railway had been opened only about a year. The Stockton and Darlington coal line, it is true, had carried passengers by steam power as early as 1825, but I think we may look upon the Manchester and Liverpool as being the beginning of the passenger and mercantile railway system of the present day. At that time the locomotives weighed from eight to ten tons, and the speed was about 20 miles per hour, with a pressure of from 40 to 50 lb. The rails were light; they were jointed in the chairs, which were generally carried on stone blocks, thus affording most excellent anvils for the battering to pieces of the ends of the rails—that is to say, for the destruction of the very parts where they were most vulnerable. The engines were not competent to draw heavy trains, and it was a common practice to have at the foot of an incline a shed containing a "bank engine," which ran out after the trains as they passed, and pushed them up to the top of the hill. Injectors were then unknown, and donkey-pumps were unknown, and therefore, when it was necessary to fill up the boiler, if it had not been properly pumped up before the locomotive came to rest, it had to run about the line in order to work its feed-pumps. To get over this difficulty, it was occasionally the practice to insert into a line of rails, in a siding, a pair of wheels, with their tops level with that of the rails so that the engine wheels could run upon the rims. Then, the locomotive being fixed to prevent it from moving off the pair of wheels thus endways, it was put into revolution, its driving wheels bearing, as already stated, upon the rims of the pair of wheels in the rails, and thus the engine worked its feed-pumps without interfering (by its needless running up and down the line) with the traffic. It should have been stated, that at this time there was no link motion, no practical expansion of the steam, and that even the reversal of the engine had to be effected by working the sides by hand gear, in the manner in use in marine engines. When the British Association originated, although the Manchester and Liverpool Railway had been opened for a year, there is no doubt that the 300 members who then came to this city found their way here by the slow process of the stage-coach, the loss of which we so much deplore in the summer and in fine weather, but the obligatory use of which we should so much regret in the miserable weather now prevailing in these islands.

In 1881, we know that railways are everywhere inserted. Steel rails, double the weight of the original iron ones, are used. Wooden sleepers have replaced the stone blocks, and they, in their turn, will probably give way to sleepers of steel. The joints are now made by means of fish-plates, and the most vulnerable part of the rail, the end, is no longer laid on an anvil for a purpose of being smashed to pieces, but the ends of the rails are now almost always over a void, and thereby are not more affected by wear than is any other part of the rail. The speed is now from 50 to 60 miles an hour for passenger trains, while slow speed goods engines, weighing 45 tons, draw behind them coal trains of 800 tons. The injector is now commonly employed, and, by its aid, a careful driver of the engine of a stopping train can fill up his boiler while at rest at the stations. The link motion is in common use, to which, no doubt, is owing the very considerable economy with which the locomotive engine now works.

As regards the question of safety, it is a fact that, notwithstanding the increased

speed, railway accidents are fewer than they were at the slow speed. It is also a fact, that if the whole population of London were to take a railway journey, there would be but one death arising out of it. Four millions of journeys for one death of a passenger from causes beyond his own control is, I believe, a state of security which rarely prevails elsewhere. As an instance, the street accidents in London alone cause between 200 and 300 deaths per annum. This safety in railway traveling is no doubt largely due to the block system, rendered possible by the electric telegraph; and also to the efficient interlocking of points and signals, which render it impossible now for a signal man to give an unsafe signal. He may give a wrong one, in the sense of inviting the wrong train to come in; but, although wrong in this sense, it would still be safe for that train to do so. If he can give a signal, that signal never invites to danger; before he can give it, every one of the signals, which ought to be "at danger," must be "at danger," and every "point" must have been previously set, so as to make the road right; then, again, we have the facing point-lock, which is a great source of safety.

### **BRAKES.**

Further, we have continuous brakes of various kinds, competent in practice to absorb three miles of speed in every second of time; that is to say, if a train were going 60 miles an hour, it can be pulled up in 20 seconds; or, if at the rate of 30 miles, in 10 seconds. With a train running at 50 miles an hour, it can be pulled up in from 15 to 20 seconds, and in a distance of from 180 to 240 yards. Moreover, in the event of the train separating into two or more sections, the brakes are automatically applied to each section, thereby bringing them to rest in a short time. Another cause of safety is undoubtedly the use of weldless tires. I was fortunate enough to attend the British Association meeting many years ago at Birmingham, and I then read a paper upon weldless tires, in which I ventured to prophesy that, in ten years' time, there would not be a welded tire made; that is one of the few prophecies that, being made before the event, have been fulfilled. I may perhaps be permitted to mention, that at the same time I laid before the section plans and suggestions for the making of the cylindrical parts of boilers equally without seam, or even welding. This is rarely done at the present time, but I am sure that, in twenty years' time, such a thing as a longitudinal seam of rivets in a boiler will be unknown. There is no reason why the successive rings of boiler shells should not be made weldless, as tires are now made weldless.

### **MOTORS.**

The next subject I intend to deal with is that of motors. In 1831, we had the steam-engine, the water-wheel, the windmill, horse-power, manual power, and Stirling's hot air engines. Gas engines, indeed, were proposed in 1824, but were not brought to the really practical stage. We had then tide mills; indeed, we have had them until quite lately, and it may be that some still exist; they were sources of economy in our fuel, and their abandonment is to me a matter of regret. I remember tide mills on the coast between Brighton and Newhaven, another between Greenwich and Woolwich, another at Northfleet, and in many other places. Indeed, such mills were used pretty extensively; they were generally erected at the mouth of a stream, and in that way the river bed made the reservoir, and even when they were erected in other situations, those were of a kind suitable for the purpose, that is, lowlying lands were selected, and were embanked to form reservoirs. In 1881, windmills and water-wheels are much the same, but the turbines are greatly improved, and by means of turbines we are enabled to make available the pressure derived from heads of water which formerly could not be used at all, or if used, involved the erection of enormous water-wheels, such as those at Glasgow and in the Isle of Man, wheels of some eighty feet in diameter. But now, by means of a small turbine, an excellent effect is produced from high heads of water. The same effect is obtained from the water-engines which our president has employed with such great success. In addition to these motors, we have the gas-engine, which, within the last few years only, has become a really useful working and economical machine. With respect to horse-power motors, we have not only the old horse engines, but we have a new application, as it seems to me, of the work of the horse as a motor. I allude to those cases where the horse drawing a reaping or thrashing machine, not only pulls it forward as he might pull a cart, but causes its machinery to revolve, so as to perform the desired kind of work. This species of horse-engine, though known, was but little used in 1831. With respect to hot-air engines there have been many attempts to improve them, and some hot-air engines are working, and are working with considerable success; but the amount of power they develop in relation to their size is small, and I am inclined to doubt whether it can be much increased.

### **TRANSMISSION OF POWER.**

I now come to the subject of the transmission of power. I do not mean transmission in the ordinary sense by means of shafting, gearing, or belting, but I mean

transmission over long distances. In 1831, we had for this purpose flat rods, as they were called, rods transmitting power from pumping engines for a considerable distance to the pits where the pumps were placed, and we had also the pneumatic, the exhaustion system—the invention of John Hague, a Yorkshire-man, my old master, to whom I was apprenticed—which mode of transmission was then used to a very considerable extent. The recollection of it, I find, however, has nearly died out, and I am glad to have this opportunity of reviving it. But in 1881, we have, for the transmission of power, first of all, quick moving ropes, and there is not, so far as I know a better instance of this system than that at Schaffhausen. Any one who has ever, in recent years, gone a mile or two above the falls at Schaffhausen, must have seen there—in a house, on the bank of the Rhine, opposite to that on which the town is situated—large turbines driven by the river, which is slightly dammed up for the purpose. These work quick-going ropes, carried on pulleys, erected at intervals along the river bank, for the whole length of the town; and power is delivered from them to shafting below the streets, and from it into any house where it is required for manufacturing purposes. Then we have the compressed air transmission of power, which is very largely used for underground engines, and for the working of rock drills in mines and tunnels.

### **COMPRESSED AIR LOCOMOTIVES.**

We have also compressed air in a portable form, and it is now employed with great success in driving tram-cars. I had occasion last January to visit Nantes, where, for eighteen months, tram-cars had been driven by compressed air, carried on the cars themselves, coupled with an extremely ingenious arrangement for overcoming the difficulties commonly attendant on the use of compressed air engines. This consists in the provision of a cylindrical vessel half filled with hot water and half with steam, at a pressure of eighty pounds on the square inch. The compressed air, on its way from the reservoir to the engine, passes through the water and steam, becoming thereby heated and moistened, and in that way all the danger of forming ice in the cylinders was prevented, and the parts were susceptible of good lubrication. These cars, which start every ten minutes from each end, make a journey of  $3\frac{3}{4}$  miles, and have proved to be a commercial and an engineering success. I believe, moreover, that they are capable of very considerable improvement.

### **HYDRAULIC TRANSMISSION OF POWER.**

Then there is, although not much used, the transmitting of power by means of long steam pipes. There is also the transmission hydraulically. This may be carried out in an intermittent manner, so as to replace the reciprocating flat rods of old days; that is to say, if two pipes containing water are laid down, and if the pressure in those pipes at the one end be alternated, there will be produced an alternating and a reciprocative effect at the other, to give motion to pumps or other machinery. There is also that thoroughly well known mode of transmission, hydraulically, for which the engineering world owes so much to our president. We have, by Sir William Armstrong's system, coupled with his accumulator, the means of transmitting hydraulically the power of a central motor to any place requiring it, and by the means of the principal accumulator, or if need be by that aided by local accumulators, a comparatively small engine is enabled to meet very heavy demands made upon it for a short time. I think I am right in saying that, at the ordinary pressure which Sir William Armstrong uses in practice, viz., 700 lb. to the square inch, one foot a second of motion along an inch pipe would deliver at the rate to produce one-horse power. Therefore, a ten-inch pipe, with the water traveling at no greater pace than three feet in a second, would deliver 300 horse-power. This 300 horse-power would no doubt be somewhat reduced by the loss in the hydraulic engine, which would utilize the water. But the total energy received would be equivalent to producing 300 horse-power. Such a transmission would be effected with an exceedingly small loss infliction in transit. I believe I am right in saying that a 10 inch pipe a mile long would not involve much more than about 14 or 15 lb. differential pressure to propel the water through it at the rate of three feet in a second. If that be so, then, with 700 lb. to the inch, the loss under such circumstances would be only two per cent. in transmission. There is no doubt that this transmission of power hydraulically has been of the greatest possible use. It has enabled work to be done which could not be done before. Enormous weights are raised with facility wherever required, as by the aid of power hydraulically transmitted, it is perfectly easy for one man to manage the heaviest cranes. Moreover, as I have said in other places, the system which we owe to Sir William Armstrong has gone far to elevate the human race, and it has done so in this manner. So long as it is competent for a man to earn a living by mere unintelligent exercise of his muscles, he is very likely to do it. You may see in the old London docks the crane-heads covered by structures that look like paddle-boxes. If you go to them, there is, I am glad to say, nothing now to fill them up; but when the British Association first met, these paddle-boxes covered large tread-wheels, in which men trod, so as to raise a weight. Now, although I know that in fact there is nothing more objectionable

in a man turning a wheel by treading inside of it than there is if he turn it round by a winch-handle, yet somehow it strikes one more as being merely the work of an animal, a turnspit, or a squirrel, or, indeed, as the task imposed on the criminal. But, nevertheless, in this way there were a large number of persons getting their living by the mere exercise of their muscles, but, as might be expected, a very poor living, derived as it was from unintelligent labor. That work is no longer possible, and is not so, for the powerful reason that it does not pay. Those persons, therefore, who would now have been thus occupied, are compelled to elevate themselves, and to become competent to earn their living in a manner which is more worthy of an intelligent human being. It is on these grounds that I say we owe very much the elevation of the working classes, especially of the class below the artisan, to this invention of our distinguished president.

### **ELECTRIC TRANSMISSION OF POWER.**

In addition to the modes of transmission I have already mentioned, there is the transmission of power by means of gas. I think that there is a very large future indeed for gas engines. I do not know whether this may be the place to state it, but I believe the way in which we shall utilize our fuel hereafter will, in all probability, not be by the way of the steam-engine. Sir William Armstrong alluded to this probability in his address, and I entirely agree, if he will allow me to say so, that such a change in the production of power from fuel appears to be impending, if not in the immediate future, at all events in a time not very far remote; and however much the Mechanical Section of the British Association may to-day contemplate with regret, even the mere distant prospect of the steam-engine being a thing of the past, I very much doubt whether those who meet here fifty years hence will then speak of it as anything more than a curiosity to be found in a museum. With respect to the transmission of power electrically, I won't venture to touch upon that; but will content myself by reminding you that while Sir William Armstrong did say that there were comparatively small streams which could be utilized, he did not inform you of that which he himself had done in this direction; let me say that Sir William Armstrong thus utilized a fall of water, situated about a mile from his house, to work a turbine, which drives a dynamo machine, generating electricity, for the illumination of the house. When I was last at Crag Side, that illumination was being effected by the arc light, but since then, as Sir William Armstrong has been good enough to write to me, he has replaced the arc light by the incandescent lamp (a form of electrical lighting far more applicable than the arc light to domestic purposes), and with the greatest possible success. Thus, in Sir William Armstrong's own case, a small stream is made to afford light in a dwelling a mile away. Certainly nothing could have seemed more improbable fifty years ago than that the light of a house should be derived from a fall of water without the employment of any kind or description of fuel.

The next subject upon which I propose to touch is that of

### **THE MANUFACTURE OF IRON AND STEEL.**

In 1831, Neilson's hot blast specification had been published for two and a half years only. The Butterly Company had tried the hot blast for the first time in the November preceding the meeting of the British Association. The heating of the blast was coming very slowly into use, and the temperature attained when it was employed was only some 600 degrees. The ordinary blast furnace of those days was 35 to 40 feet high, and about 12 feet diameter at the boshes, and turned out about 60 tons a week. It used about 2½ tons of coal per ton of iron, and no attempt was made to utilize the waste gases, whether escaping in the form of gas or in the form of flame, the country being illuminated for miles around at night by these fires. The furnaces were also open at the hearth, and continuous fire poured out along with the slag.

In 1881, blast furnaces are from 90 ft. to 100 ft. high, and 25 ft. in diameter at the boshes; they turn out from 500 to 800 tons a week. The tops and also the hearths are closed, and the blast—thanks to the use of Mr. E.A. Cowper's stoves—is at 1,200 degrees. The manufacture of iron has also now enlisted in its service the chemist as well as the engineer, and among those who have done much for the improvement of the blast furnaces, to no one is greater praise due than to Mr. Isaac Lowthian Bell, who has brought the manufacture of iron to the position of a highly scientific operation. In the production of wrought iron by the puddling process, and in the subsequent mill operations, there is no very considerable change, except in the magnitude of the machines employed, and, in the greater rapidity with which they now run. In saying this, I am not forgetting the various "mechanical puddlers" which have been put to work, nor the attempts that have been made by the use of some of them to make wrought iron direct from the ore; but neither the "mechanical puddler" nor the "direct process" has yet come into general use; and I desire to be taken as speaking of that which is the ordinary process pursued at the present in puddled iron manufactures. In 1831, a few hundredweights was the limit of weight of a plate, while in 1881, there may readily be obtained, for boiler-making purposes, plates of at

least four times the weight of those that were made in 1831. I may, perhaps, be allowed to say that there is an extremely interesting blue-book of the year 1818, containing the report of a parliamentary committee which sat on boiler explosions, and I recommend any mechanical engineer who is interested in the history of the subject to read that book; he will find it there stated that in the North of England there was a species of engines called locomotives, the boilers of which were made of wrought iron, beaten, not rolled, because the rolled plate was not considered fit; it was added that if made of beaten iron the boiler would last at least a year.

In 1831, thirteen years later, the dimensions of rolled plates were no doubt raised; but few then would have supposed it possible there should be rolled such plates as are now produced for boiler purposes, and still fewer would have believed that in the year 1881 we should make, for warlike purposes, rolled plates 22 inches in thickness and 30 tons in weight. I have said there is very little alteration in the process of making wrought iron by puddling, and I do not think there is likely to be much further, if any, improvement in this process, because I believe that, with certain exceptions, the manufacture of iron by puddling is a doomed industry. I ventured to say, in a lecture I delivered at the Royal Institution three years ago on "The Future of Steel," that I believed puddled iron, except for the mere hand wrought forge purposes of the country blacksmith, and for such like purposes, would soon become a thing of the past. Mr. Harrison, the engineer of the North-Eastern Railway, told me that about eighteen months ago the North-Eastern Railway applied for tenders for rails in any quantities between 2,000 and 10,000 tons, and they issued alternative specifications for iron and for steel. They received about ten tenders. Some did not care to tender for iron at all; but when they did tender alternatively, the price quoted for the iron was greater than for the steel. I have no doubt whatever that, in a short time, it will be practically impossible to procure iron made by the puddling process, of dimensions fit for many of the purposes for which a few years ago it alone was used.

With respect to steel, in 1831 the process in use was that of cementation, producing blistered steel, which was either piled and welded to make shear steel, or was broken into small pieces, melted in pots, and run into an ingot weighing only some 50 lb. or 60 lb. At that time steel was dealt in by the pound; nobody thought of steel in tons. In 1881, we are all aware that, by Sir Henry Bessemer's well-known discovery, carried out by him with such persistent vigor, cast iron is, by the blowing process, converted into steel, and that of Dr. Siemens' equally well-known process (now that, owing to his invention of the regenerative furnace, it is possible to obtain the necessary high temperature), steel is made upon the open hearth. We are, moreover, aware that, by both of these processes, steel is produced in quantities of many tons at a single operation, with the result that as instanced in the case of the North-Eastern rails, steel is a cheaper material than the wrought iron made by the puddling process. One cannot pass away from the steel manufacture without alluding to Sir Joseph Whitworth's process of putting a pressure on the steel while in a tried state. By this means, the cavities which are frequently to be found in the ingot of a large size are, while the steel is fluid, rendered considerably smaller, and the steel is thereby rendered much more sound. In conclusion of my observations on the subject of iron and steel manufacture, I wish to call attention to the invention of Messrs. Thomas & Gilchrist, by which ores of iron, containing impurities that unfitted them to be used in the manufacture of steel, are now freed from these impurities, and are thus brought into use for steel-making purposes.

## **BRIDGES.**

In the year 1831, bridges of cast iron existed; but no attempt had been made to employ wrought iron in girder bridges, although Telford had employed it in the Menai Suspension Bridge; but in 1881, the introduction of railways, and the improvement in iron manufactures, have demanded, and have rendered possible the execution of such bridges as the tubular one, spanning the Menai Straits, in span of 400 feet, and the Saltash, over the Tamar, with spans of 435 feet; while recent great improvements in the manufacture of steel have rendered possible the contemplated construction of the Forth Bridge, where there are to be spans of 1,700 feet, or one-third of a mile in length. Mr. Barlow, one of the engineers of this bridge, has told me that there will be used upwards of 2,000 more tons of material in the Forth Bridge, to resist the wind pressure, than would have been needed if no wind had to be taken into account, and if the question of the simple weight to be carried had alone to be considered. With respect to the foundation of bridges, that ingenious man, Lord Cochrane, patented a mode of sinking foundations, even before the first meeting of the British Association, viz., as far back, I believe, as 1825 or 1826; and the improvements which he then invented are almost universally in use in bridge construction at the present day. Cylinders sunk by the aid of compressed air, airlocks to obtain access to the cylinder, and, in fact, every means that I know of as having been used in the modern sinking of cylinder foundations, were described by Lord Cochrane (afterwards Earl of Dundonald) in that specification.

The next subject I propose to touch on is that of

## **MACHINE TOOLS.**

In 1831, the mention of lathes, drilling machines, and screwing machines brings me very nearly to the end of the list of the machine tools used by turners and fitters, and at that time many lathes were without slide rests. The boiler-maker had then his punching-press and shearing machine; the smith, leaving on one side his forges and their bellows, had nothing but hand tools, and the limit of these was a huge hammer, with two handles, requiring two men to work it. In anchor manufacture, it is true, a mechanical drop-hammer, known as a Hercules, was employed, while in iron works, the Helve and the Tilt hammer were in use. For ordinary smith's work, however, there were, as has been said, practically no machine tools at all.

This paucity or absence in some trades, as we have seen, of machine tools, involved the need of very considerable skill on the part of the workman. It required the smith to be a man not only of great muscular power, but to be possessed of an accurate eye and a correct judgment, in order to produce the forgings which were demanded of him, and to make the sound work that was needed, especially when that soundness was required in shafts, and in other pieces which, in those days, were looked upon as of magnitude; which, indeed, they were, relatively to the tools which could be brought to operate upon them. The boiler-maker in his work had to trust almost entirely to the eye for correctness of form and for regularity of punching, while all parts of engines and machines which could not be dealt with in the lathe, in the drilling, or in the screwing machine, had to be prepared by the use of the chisel and the file.

At the present day, the turning and fitting shops are furnished not only with the slide lathe, self acting in both directions, and screw-cutting, the drilling-machine, and the screwing machine, but with planing machines competent to plane horizontally, vertically, or at an angle; shaping machines, rapidly reciprocating, and dealing with almost any form of work; nut shaping machines, slot drilling machines, and slotting machines, while the drills have become multiple and radial; and the accuracy of the work is insured by testing on large surface plates, and by the employment of Whitworth internal and external standard gauges.

The boiler maker's tools now comprise the steam, compressed air, hydraulic or other mechanical riveter, rolls for the bending of plates while cold into the needed cylindrical or conical forms, multiple drills for the drilling of rivet holes, planing machines to plane the edges of the plates, ingenious apparatus for flanging them, thereby dispensing with one row of rivets out of two, and roller expanders for expanding the tubes in locomotive and in marine boilers; while the punching press, where still used, is improved so as to make the holes for seams of rivets in a perfect line, and with absolute accuracy of pitch.

With respect to the smith's shop, all large pieces of work are now manipulated under heavy Nasmyth or other steam hammers; while smaller pieces of work are commonly prepared either in forging machines or under rapidly moving hammers, and when needed in sufficient numbers are made in dies. And applicable to all the three industries of the fitting shop, the boiler shop, and the smith's shop, and also to that other industry carried on in the foundry, are the traveling and swing cranes, commonly worked by shafting, or by quick moving ropes for the travelers, and by hydraulic power or by steam engines for the swing cranes. It may safely be said, that without the aid of these implements, it would be impossible to handle the weights that are met with in machinery of the present day.

I now come to one class of machine which, humble and small as it is, has probably had a greater effect upon industry and upon domestic life than almost any other. I mean

## **THE SEWING MACHINE.**

In 1831, there was no means of making a seam except by the laborious process of the hand needle. In 1846, Eldred Walker patented a machine for parsing the basting thread through the gores of umbrellas, a machine that was very ingenious and very simple, but was utterly unlike the present sewing machine, with its eye-pointed needle, using sometimes two threads (the second being put in by a shuttle or by another needle), and making stitches at twenty-fold the rapidity with which the most expert needlewoman could work. By means of the sewing machine not only are all textile fabrics operated upon, but even the thickest leather is dealt with, and as a *tour de force*, but as a matter of fact, sheet-iron plates themselves have been pierced, and have been united by a seam no boilermaker ever contemplated, the piercing and the seam being produced by a Blake sewing machine. I believe all in this section will agree that the use of the sewing machine has been unattended by loss to those who earn their living by the needle; in fact, it would not be too much to say that there has

been a positive improvement in their wages.

The next matter I have to touch upon is

### **AGRICULTURAL MACHINERY.**

In 1831, we had thrashing machines and double plows, and even multiple plows had been proposed, tried, and abandoned. Reaping machines had been experimented with and abandoned; sowing machines were in use, but not many of them; clod crushers and horse rakes were also in use; but as a fact plowing was done by horse power with a single furrow at a time, mowing and reaping were done by the scythe or the sickle, sheaves were bound by hand, hay was tedded by hand-rakes, while all materials and produce were moved about in carts and in wagons drawn by horses. At the present time we have multiple plows, making five or six furrows at a time, these and cultivators also, driven by steam, commonly from two engines on the head lands, the plow being in between, and worked by a rope from each engine, or if by one engine, a capstan on the other head land, with a return rope working the plow backward and forward; or by what is known as the roundabout system, where the engine is fixed and the rope carried round about the field; or else plows and cultivators are worked by ropes from two capstans placed on the two head lands, and driven by means of a quick-going rope, actuated by an engine, the position of which is not changed. And then we have reaping machines, driven at present by horses; but how long it will be before the energy residing in a battery, or that in a reservoir of compressed air, will supersede horse power to drive the reaping machine, I don't know, but I don't suppose it will be very long. The mowing and reaping machines not only cut the crop and distribute it in swaths, or, in the case of the reaping machine, in bundles, but now, in the instance of these latter machines, are competent to bind it into sheaves. In lieu of hand tedding, haymaking machines are employed, tossing the grass into the air, so as to thoroughly aerate it, taking advantage of every brief interval of fine weather; and seed and manure are distributed by machine with unflinching accuracy. The soil is drained by the aid of properly constructed plows for preparing the trenches; roots are steamed and sliced as food for cattle; and the thrashing machine no longer merely beats out the grain, but it screens it, separates it, and elevates the straw, so as to mechanically build it up into a stack. I do not know a better class of machine than the agricultural portable engine. Every part of it is perfectly proportioned and made; it is usually of the locomotive type, and the economy of fuel in its use is extremely great. I cannot help thinking that the improvement in this respect which has taken place in these engines, and the improvement of agricultural machinery generally, is very largely due to the Royal Agricultural Society, one of the most enterprising bodies in England.

I now come to the very last subject I propose to speak upon, and that is

### **PRINTING MACHINERY,**

and especially as applied to the printing of newspapers. In 1831, we had the steam press sending out a few hundred copies in an hour, and doing that upon detached sheets, and thus many hours were required for an edition of some thousands. The only way of expediting the matter would have been to have recomposed the paper, involving, however, double labor to the compositors, and a double chance of error. At the present day, we have, by the Walter press, the paper printed on a continuous sheet at a rate per hour at least three times as great as that of the presses of 1831, and, by the aid of *papier mâché* moulds, within five minutes from the starting of the first press, a second press can be got to work from the stereotype plates, and a third one in the next five minutes; and thus the wisdom of our senators, which has been delivered as late as three o'clock in the morning, is able to be transmitted by the newspaper train leaving Euston at 5:15 A.M.

This is the last matter with which I shall trouble the Section. I have purposely omitted telegraphy; I have purposely omitted artillery, textile fabrics, and the milling and preparation of grain. These and other matters I have omitted for several reasons. Some I have omitted because I was incompetent to speak upon them, others because of the want of time, and others because they more properly belong to Section A.

I hope, sir, although your address, dealing with the future, was undoubtedly the right address for a president to deliver, and although it is equally right that we should not content ourselves with merely looking back in a "rest and be thankful" spirit at the various progress which this paper records, it may nevertheless be thought well that there should have been brought before the section, in however cursory a manner, some notice of mechanical development during the past fifty years.

[1]

Paper read in Section G (Mechanical) of the British Association.



## AMATEUR MECHANICS.

### METAL TURNING.

In selecting a lathe an amateur may exercise more or less taste, and he may be governed somewhat by the length of his purse; the same is true in the matter of chucks; but when he comes to the selection or making of turning tools he must conform to fundamental principles; he must profit as far as possible by the experience of others, and will, after all, find enough to be learned by practice.

Tools of almost every description may be purchased at reasonable prices, but the practice of making one's own tools cannot be too strongly recommended. It affords a way out of many an emergency, and where time is not too valuable, a saving will be realized. A few bars of fine tool steel, a hammer, and a small anvil, are all that are required, aside from fire and water. The steel should be heated to a low red, and shaped with as little hammering as possible; it may then be allowed to cool slowly, when it may be filed or ground to give it the required form. It may now be hardened by heating it to a cherry red and plunging it straight down into clean cool (not too cold) water. It should then be polished on two of its sides, when the temper may be drawn in the flame of an alcohol lamp or Bunsen gas burner; or, if these are not convenient, a heated bar of iron may be used instead, the tool being placed in contact with it until the required color appears. This for tools to be used in turning steel, iron, and brass may be a straw color. For turning wood it may be softer. The main point to be observed in tempering a tool is to have it as hard as possible without danger of its being broken while in use. By a little experiment the amateur will be able to suit the temper of his tools to the work in hand.

In the engraving accompanying the present article a number of hand turning tools are shown, also a few tools for the slide rest. These tools are familiar to machinists and may be well known to many amateurs; but we give them for the benefit of those who are unacquainted with them and for the sake of completeness in this series of articles.

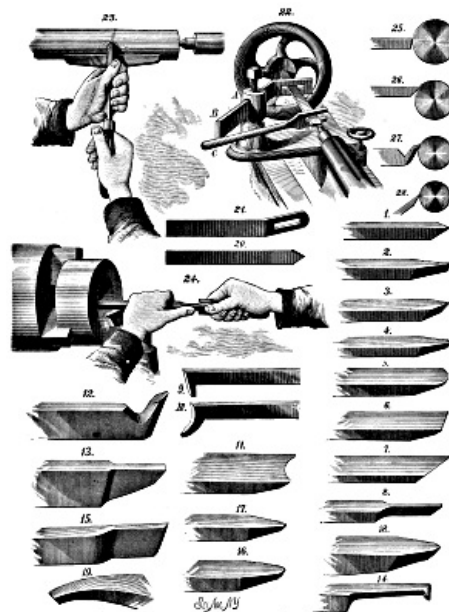

TURNING TOOLS.

Fig. 1 is the ordinary diamond tool, made from a square bar of steel ground diagonally so as to give it two similar cutting edges. This tool is perhaps more generally useful than any of the others. The manner of using it is shown in Fig. 23; it is placed on the tool rest and dexterously moved on the rest as a pivot, causing the point to travel in a circular path along the metal in the lathe. Of course only a small distance is traveled over before the tool is moved along on the rest. After a little experience it will be found that by exercising care a good job in plain turning may be done with the tool.

Fig. 2 shows a sharp V shaped tool which will be found useful for many purposes. Fig. 3 is a V shaped tool for finishing screw threads. Figs. 4 and 5 are round-nosed tools for concave surfaces; Fig. 6, a square tool for turning convex and plane surfaces. The tool shown in Fig. 7 should be made right and left; it is useful in turning brass, ivory, hard wood, etc. Fig. 8 is a separating tool; Fig. 9 is an inside tool, which should be made both right and left, and its point may be either round, V shaped, or square. Fig. 24 shows the manner of holding an inside tool. Fig. 10 is a

tool for making curved undercuts. Fig. 11 is a representative of a large class of tools for duplicating a given form.

These figures represent a series of tools which may be varied infinitely to adapt them to different purposes. The user, if he is wide awake, is not long in discovering what angle to give the cutting edge, what shape to give the point, and what position to give the tool in relation to the work to be done.

Having had experience with hand tools it requires only a little practice and observation to apply the same principles to slide rest tools.

A few examples of this class of tools are given. Fig. 12 is the ordinary diamond pointed tool, which should be made right and left. The cutting edge may have a more or less acute angle, according to the work to be done, and the inclined or front end of the tool may be slightly squared or rounded, according to the work. Fig. 13 is a separating tool, which is a little wider at the cutting edge than any where else, so that it will clear itself as it is forced into the work.

For brass this tool should be beveled downward slightly. By giving the point the form shown in Fig. 3 it will be adapted to screw cutting.

Fig. 14 shows an inside tool for the slide rest; its point may be modified according to the work to be done. Fig. 15 is a side tool for squaring the ends of shafts; Figs. 16, 17, 18, and 19 represent tools for brass, Fig. 16 is a round-nosed tool for brass, Fig. 17 a V shaped tool, Fig. 18 a screw thread tool, and Fig. 19 a side tool. In boring, whether the object is cored or not, it is desirable, where the hole is not too large, to take out the first cut with a drill. The drill for the purpose is shown in Fig. 20, the drill holder in Fig. 21, and the manner of using in Fig. 22. The drill holder, B, is held by a mortised post placed in the rest support. The slot of the drill holder is placed exactly opposite the tail center and made secure. The drill, which is flat, is drilled to receive the tail center, and it is kept from turning by the holder, and is kept from lateral movement and chattering by a wrench, C, which is turned so as to bind the drill in the slot of the holder.

The relative position of the tool and work is shown in Figs. 25, 26, 27, and 28; Fig. 25 shows the position for brass; Fig. 26 for iron and steel; Fig. 27 the relative position of the engine rest tool and its work; and Fig. 28 the position of the tool for soft metal and wood.

In all of these cases the point of the tool is above the center of the work. In the matter of the adjustment of the tool, as well as in all other operations referred to, experiment is recommended as the best means of gaining valuable knowledge in the matter of turning metals.

## **ROTARY CUTTERS.**

The saving of files, time, materials, and patience, by the employment of such rotary cutters as may be profitably used in connection with a foot lathe, can hardly be appreciated by one who has never attempted to use this class of tools. It is astonishing how much very hard labor may be saved by means of a small circular saw like that shown in Fig. 1. This tool, like many others described in this series of articles, can, in most instances, be purchased cheaper than it can be made, and the chances are in favor of its being a more perfect article. However, it is not so difficult to make as one might suppose. A piece of sheet steel may be chucked upon the face plate, or on a wooden block attached to the face plate, where it may be bored to fit the saw mandrel, and cut in circular form by means of a suitable hand tool. It may then be placed upon the mandrel and turned true, and it is well enough to make it a little thinner in the middle than at the periphery.

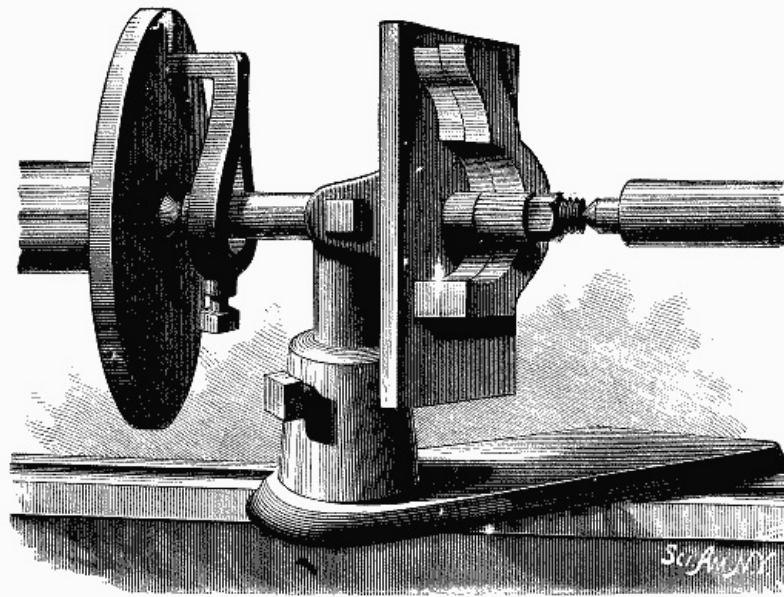

**Rotary Cutting Tools.**

There are several methods of forming the teeth on a circular saw. It may be spaced and filed, or it may be knurled, as shown in Fig. 2, and then filed, leaving every third or fourth tooth formed by the knurl, or it may, for some purposes, be knurled and not filed at all. Another way of forming the teeth is to employ a hub, something like that used in making chasers, as shown in Fig. 3, the difference between this hub and the other one referred to, is that the thread has one straight side corresponding with the radial side of the tooth. The blank from which the saw is made is placed on a stud projecting from a handle made specially for the purpose, and having a rounded end which supports the edge of the blank, as the teeth are formed by the cutters on the hub.

The saw, after the teeth are formed, may be hardened and tempered by heating it slowly until it attains a cherry red, and plunging it straight down edgewise into cool, clean water. On removing it from the water it should be dried, and cleaned with a piece of emery paper, and its temper drawn to a purple, over a Bunsen gas flame, over the flame of an alcohol lamp, or over a hot plate of iron. The small saw shown in Fig. 4 is easily made from a rod of fine steel. It is very useful for slotting sheet brass and tubes, slotting small shafts, nicking screws, etc. Being quite small it has the advantage of having few teeth to keep in order, and it may be made harder than those of larger diameter. A series of them, varying in diameter from one eighth to three eighths of an inch, and varying considerably in thickness, will be found very convenient.

These cutters or saws, with the exception of the smaller one, may be used to the best advantage in connection with a saw table, like that shown in Fig. 8. This is a plane iron table having a longitudinal groove in its face to receive the guiding rib of the carriage, shown in Fig. 9, and a transverse groove running half way across, to receive a slitting gauge, as shown in Fig. 8. The table is supported by a standard or shank, which fits into the tool-rest socket. The saw mandrel is supported between the centers of the lathe, and the saw projects more or less through a slot formed in the table. The gauge serves to guide the work to be slotted, and other kinds of work may be placed on or against the carriage, shown in Fig. 9.

It is a very simple matter to arrange guiding pieces for cutting at any angle, and the saw table may be used for either metal or wood. The saws for wood differ from those used for metal; the latter are filed straight, the former diagonally or fleaming. Among the many uses to which metal saws may be applied we mention the slitting of sheet metals, splitting wires and rods, slotting and grooving, nicking screws, etc. Fig. 10 shows a holder for receiving screws to be nicked. It is used in connection with the saw table, and is moved over the saw against the gauge.

To facilitate the removal of the screws the holder may be split longitudinally and hinged together. Another method of nicking screws is illustrated by Fig. 11. A simple lever, fulcrumed on a bar held by the tool post, is drilled and tapped in the end to receive the screw. After adjusting the tool all that is required is to insert the screw and press down the handle so as to bring the screw head into contact with the saw.

Where a lathe is provided with an engine rest, the cutter shown in Fig. 6, mounted on the mandrel shown in Fig. 5, is very useful; it is used by clamping the work to the slide rest and moving it under the cutter by working the slide rest screw.

To make a cutter of this kind is more difficult than to make a saw, and to do it readily

a milling machine would be required. It may be done, however, on a plain foot lathe, by employing a V-shaped cutter and using a holder (Fig. 7) having an angular groove for receiving the cylinder on which the cutting edges are formed. The blank can be spaced with sufficient accuracy, by means of a fine pair of dividers, and after the first groove is cut there will be no difficulty in getting the rest sufficiently accurate, as a nib inserted in the side of the guide enters the first groove and all of the others in succession and regulates the spacing.

One of the best applications of this tool is shown in the small engraving. In this case a table similar to the saw table before described is supported in a vertical position, and arranged at right angles with the cutter mandrel. The mandrel is of the same diameter as the cutter, and serves as a guide to the pattern which carries the work to be operated upon. The principal use of this contrivance is to shape the edges of curved or irregular metal work. The casting to be finished is fastened—by cement if small, and by clamps if large—to a pattern having exactly the shape required in the finished work.

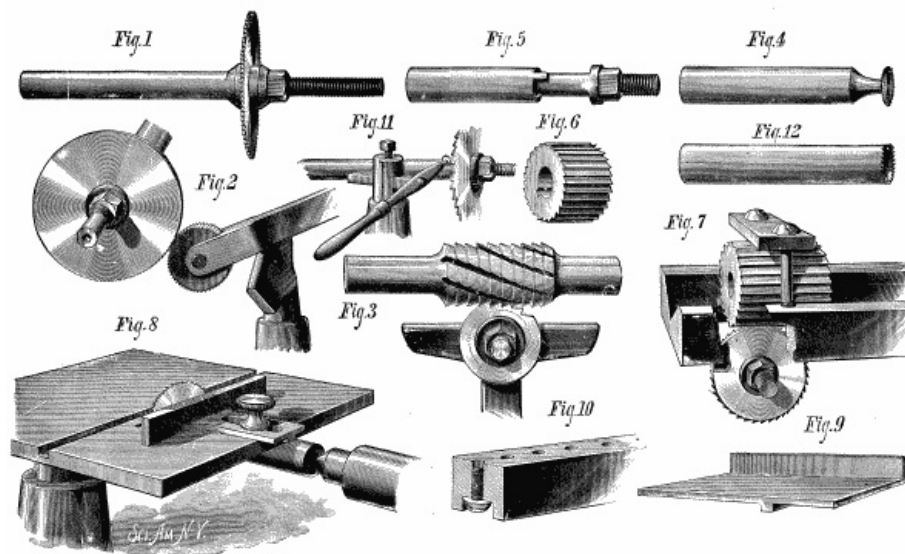

**METAL SHAPING.**

By moving the pattern in contact with the table and the mandrel, while the latter revolves, the edges of the work will be shaped and finished at the same time. By substituting a conical cutter for a cylindrical one, the work may be beveled; by using both, the edge may be made smooth and square, while the corner is beveled.

The tool shown in Fig. 12 might properly be called a barrel saw. It is made by drilling in the end of a steel rod and forming the teeth with a file. To avoid cracking in tempering a small hole should be drilled through the side near the bottom of the larger hole. To insure the free working of the tool it should be turned so that its cutting edge will be rather thicker than the position behind it. This tool should be made in various sizes.

Tools for gear cutting and also cutters for wood have not been mentioned in this paper; as they are proper subjects for separate treatment.

## **WOOD WORKING.**

It is not the intention of the writer to enter largely into the subject of wood working, but simply to suggest a few handy attachments to the foot lathe which will greatly facilitate the operations of the amateur wood worker, and will be found very useful by almost any one working in wood. It is not an easy matter to split even thin lumber into strips of uniform width by means of a handsaw, but by using the circular saw attachment, shown in Fig. 1, the operation becomes rapid and easy, and the stuff may be sawed or slit at any desired angle or bevel. The attachment consists of a saw mandrel of the usual form, and a wooden table supported by a right angled piece, A, of round iron fitted to the toolpost and clamped by a wooden cleat, B, which is secured to the under side of the table, split from the aperture to one end, and provided with a thumbscrew for drawing the parts together. By means of this arrangement the table may be inclined to a limited angle in either direction, the slot through which the saw projects being enlarged below to admit of this adjustment.

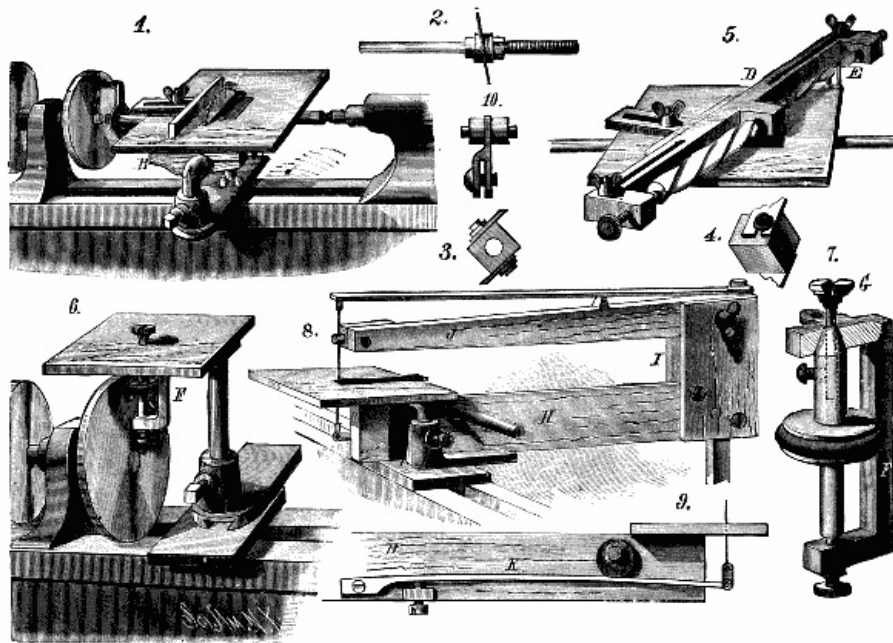

### WOODWORKING ATTACHMENTS FOR THE FOOT LATHE.

The back of the table is steadied by a screw which rests upon the back end of the tool rest support, and enters a block attached to the under side of the table. The gauge at the top of the table is used in slitting and for other purposes which will be presently mentioned, and it is adjusted by aid of lines made across the table parallel with the saw.

For the purpose of cross cutting or cutting on a bevel a thin sliding table is fitted to slide upon the main table, and is provided with a gauge which is capable of being adjusted at any desired angle. For cutting slots for panels, etc., thick saws may be used, or the saw may be made to wobble by placing it between two beveled washers, as shown in Fig. 2.

The saw table has an inserted portion, C, held in place by two screws which may be removed when it is desired to use the saw mandrel for carrying a sticker head for planing small strips of moulding or reeding. The head for holding the moulding knives is best made of good tough brass or steam metal. The knives can be made of good saw steel about one-eighth inch thick. They may be filed into shape and afterward tempered. They are slotted and held to their places on the head by means of quarter-inch machine screws. It is not absolutely necessary to use two knives, but when only one is employed a counterbalance should be fastened to the head in place of the other. All kinds of moulding, beading, tonguing, and grooving may be done with this attachment, the gauge being used to guide the edge of the stuff. If the boards are too thin to support themselves against the action of the knives they must be backed up by a thick strip of wood planed true. The speed for this cutter head should be as great as possible.

Fig. 5 shows an attachment to be used in connection with the cutter head and saw table for cutting straight, spiral, or irregular flutes on turned work. It consists of a bar, D, carrying a central fixed arm, and at either end an adjustable arm, the purpose of the latter being to adapt the device to work of different lengths. The arm projecting from the center of the bar, D, supports an arbor having at one end a socket for receiving the twisted iron bar, E, and at the other end a center and a short finger or pin. A metal disk having three spurs, a central aperture, and a series of holes equally distant from the center and from each other, is attached by its spurs to the end of the cylinder to be fluted, and the center of the arbor in the arm, D, enters the central hole in the disk while its finger enters one of the other holes. The opposite end of the cylinder is supported by a center screw. A fork attached to the back of the table embraces the twisted iron, E, so that as the wooden cylinder is moved diagonally over the cutter it is slowly rotated, making a spiral cut. After the first cut is made the finger of the arbor is removed from the disk and placed in an adjoining hole, when the second cut is made, and so on.

Figs. 6 and 7 show a convenient and easily made attachment for moulding the edges of irregular work, such as brackets, frames, parts of patterns, etc. It consists of a brass frame, F, supporting a small mandrel turning at the top in a conical bearing in the frame, and at the bottom upon a conical screw. A very small grooved pulley is fastened to the mandrel and surrounded by a rubber ring which bears against the face plate of the lathe, as shown in the engraving. The frame, F, is let into a wooden table supported by an iron rod which is received by the tool rest holder of the lathe. The cutter, G, is made by turning upon a piece of steel the reverse of the required moulding, and slotting it transversely to form cutting edges. The shank of the cutter

is fitted to a hole in the mandrel and secured in place by a small set screw. The edge of the work is permitted to bear against the shank of the cutter. Should the face plate of the lathe be too small to give the required speed, a wooden disk may be attached to it by means of screws and turned off.

Figs. 8, 9, and 10 represent a cheaply and easily made scroll saw attachment for the foot lathe. It is made entirely of wood and is practically noiseless. The board, H, supports two uprights, I, between which is pivoted the arm, J, whose under side is parallel with the edge of the board. A block is placed between the uprights, I, to limit the downward movement of the arm, and the arm is clamped by a bolt which passes through it and through the two uprights and is provided with a wing nut.

A wooden table, secured to the upper edge of the board, H, is perforated to allow the saw to pass through, and is provided with an inserted hardwood strip which supports the back of the saw, and which may be moved forward from time to time and cut off as it becomes worn. The upper guide of the saw consists of a round piece of hard wood inserted in a hole bored in the end of the arm, J. The upper end of the saw is secured in a small steel clamp pivoted in a slot in the end of a wooden spring secured to the top of the arm, J, and the lower end of the saw is secured in a similar clamp pivoted to the end of the wooden spring, K. Fig. 10 is an enlarged view showing the construction of clamp.

The relation of the spring, K, to the board, H, and to the other part is shown in Fig. 9. It is attached to the side of the board and is pressed upward by an adjusting screw near its fixed end.

The saw is driven by a wooden eccentric placed on the saw mandrel shown in Figs. 1 and 2, and the spring, K, always pressed upward against the eccentric by its own elasticity, and it is also drawn in an upward direction by the upper spring. This arrangement insures a continuous contact between the spring, K, and the eccentric, and consequently avoids noise. The friction surfaces of the eccentric and spring may be lubricated with tallow and plumbago. The eccentric may, with advantage, be made of metal.

The tension of the upper spring may be varied by putting under it blocks of different heights, or the screw which holds the back end may be used for this purpose.

The saw is attached to the lathe by means of an iron bent twice at right angles, attached to the board, H, and fitted to the tool rest support. The rear end of the sawing apparatus may be supported by a brace running to the lower part of the lathe or to the floor.

The simple attachments above described will enable the possessor to make many small articles of furniture which he would not undertake without them, and for making models of small patterns they are almost invaluable.

---

## **A NEW METHOD OF KEEPING MECHANICAL DRAWINGS.<sup>1</sup>**

The system of keeping drawings now in use at the works of the Southwark Foundry and Machine Company, in Philadelphia, has been found so satisfactory in its operation that it seems worthy of being communicated to the profession.

The method in common use, and which may be called the natural method, is to devote a separate drawer to the drawings of each machine, or of each group or class of machines. The fundamental idea of this system, and its only one, is, keeping together all drawings relating to the same subject matter.

Every draughtsman is acquainted with its practical working. It is necessary to make the drawing of a machine, and of its separate parts, on sheets of different sizes. The drawer in which all these are kept must be large enough to accommodate the largest sheets. The smaller ones cannot be located in the drawer, and as these find their way to one side or to the back, and several of the smallest lie side by side in one course, any arrangement of the sheets in the drawer is out of the question.

The operation of finding a drawing consists in turning the contents of the drawer all up until it is discovered. In this way the smaller sheets get out of sight or doubled up, and the larger ones are torn. No amount of care can prevent confusion.

Various plans have been adopted in different establishments intended to remedy this state of things, but it is believed that none has been hit upon so convenient, in all respects, as the one now to be presented.

The idea of keeping together drawings relating to the same machine, or of classifying

them according to subjects in any way, is entirely abandoned, and in place of these is substituted the plan of keeping together all drawings that are made on sheets of the same size, without regard to the subject of them.

Nine sizes of sheets were settled upon, as sufficient to meet our requirements, and on a sheet that will trim to one of these sizes every drawing must be made. They are distinguished by the first nine letters of the alphabet. Size A is the antiquarian sheet trimmed, and the smaller sizes will cut from this sheet, without waste, as follows:

A, 51×30 in.; B, 37×30 in.; C, 25×30 in.; D, 17×30 in.; E 12½×30 in.; F, 8½×30 in.; G, 17×15 in.; H, 8½×15 in.; I, 14×25 in.

The drawers for the different sizes are made one inch longer and wider than the sheets they are to contain, and are lettered as above. Those of the same size, after the first one, are distinguished by a numeral prefixed to the letter. The back part of each drawer is covered for a width of from six to ten inches, to prevent drawings, and especially tracings, from slipping over at the back.

The introduction of the blue printing process has quite revolutionized the drawing office, so far at least as we are concerned. Our drawings are studies, left in pencil. When we can find nothing more to alter, tracings are made on cloth. These become our originals, and are kept in a fire-proof vault. This system is found admirably adapted to the plan of making a separate drawing for each piece. The whole combined drawing is not generally traced, but the separate pieces are picked out from it. All our working copies are blue prints.

Each drawer contains fifty tracings. They are two and a half inches deep, which is enough to hold several times as many, but this number is quite all that it is convenient to keep together. We would recommend for these shallower drawers.

Each drawing is marked in stencil in the lower right hand corner, and also with inverted plates in the upper left hand corner, with the letter and number of the drawer, and its own number in the drawer, as, for example, 3F—31; so that whichever way the sheet is put in the drawer, this appears at the front right hand corner. The drawings in each drawer are numbered separately, fifty being thus the highest number used.

For reference we depend on our indices. Each tracing, when completed, is entered under its letter in the numerical index, and is given the next consecutive number, and laid in its place.

From this index the title and the number are copied into other indices, under as many different headings as possible.

Thus all the drawings of any engine, or tool, or machine whatever, become assembled by their titles under the heading of such particular engine, or tool, or machine. So also the drawings of any particular part, of all sizes and styles, become assembled by their titles under the name of such piece. However numerous the drawings, and however great the variety of their subjects, the location of any one is, by this means, found as readily as a word in a dictionary. The stencil marks copy, of course, on the blue prints, and these when not in use are kept in the same manner as the tracings, except that only twenty-five are placed in one drawer.

We employ printed classified lists of the separate pieces constituting every steam engine, the manufacture of which is the sole business of these works, and on these, against the name of every piece, is given the drawer and number of the drawing on which it is represented. The office copies of these lists afford an additional mode of reference and a very convenient one, used in practice almost exclusively. The foreman sends for the prints by the stencil marks, and these are thus got directly without reference to any index. They are charged in the same way, and reference to the numerical index gives the title of any missing print.

We find the different sizes to be used quite unequal. The method of making a separate tracing of each piece, which we carry to a great extent, causes the smaller sizes to multiply quite rapidly. We are marking our patterns with the stencil of the drawing of the same piece; and also, gauges, templets, and jigs.

It is found best to permit the sheets to be put away by one person only, who also writes up the indices, which are kept in the fire proof.

We were ourselves surprised at the saving of room which this system has effected. Probably less than one-fourth the space is occupied that the same drawings would require if classified according to subjects.

The system is completely elastic. Work of the most diverse character might be undertaken every day, and the drawings of each article, whether few or many, would find places ready to receive them.

## ACHARD'S ELECTRIC BRAKE.

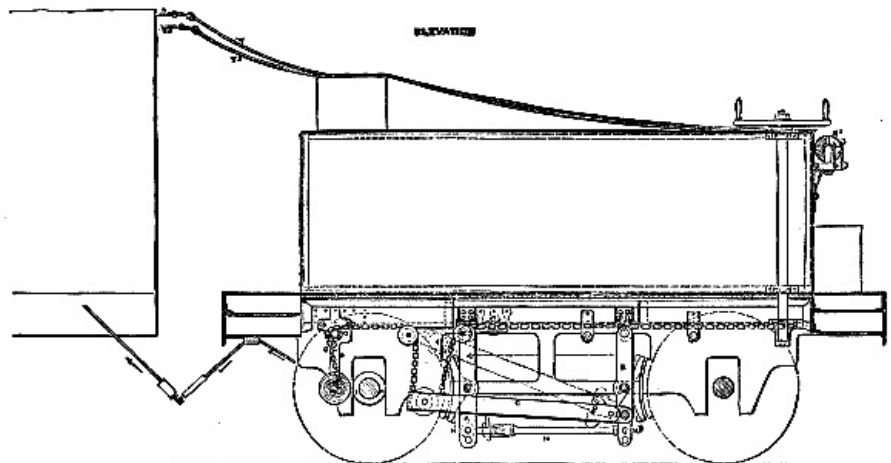

ELEVATION.

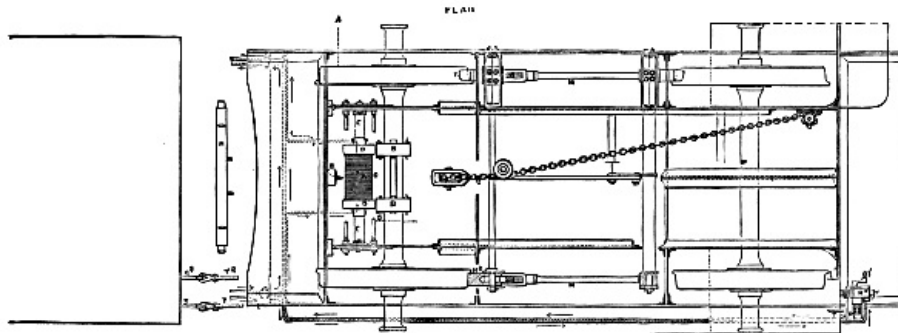

PLAN.

### ACHARD'S ELECTRIC BRAKE—EASTERN RAILWAY OF FRANCE.

The merits of a brake in which electric apparatus is used, that has been adopted by one large railway company, and is about to be used on the State railways, as well as the fact that arrangements are being made to introduce it in England, demand consideration. It may be that modifications will, under different circumstances, be introduced, or that the system will ultimately be found too cumbersome or too delicate, but before criticism it is necessary to know something of the apparatus. We therefore endeavor to give somewhat in detail the arrangement adopted by M.L. Regray, chief engineer of the Chemin de Fer de l'Est, the electrical system being that of M. Achard. An electro-magnet, A, is suspended on a hinged axis, so that the poles of the magnet have for armatures cylinders of metal fixed upon the axle of the carriage. Suppose now the poles, D D, of the magnet brought into contact with the revolving armatures, the friction between them causes the magnet to revolve. The chain attached to the brake is fixed to the extended axle of the magnet, and consequently when that axle revolves is wound up, bringing the brakes upon the wheels. The friction between the poles and the armature depends upon the strength of the magnet, and this can be regulated at will from a maximum to a minimum. But it will be well to trace the whole action. The electric current may be obtained by means of Planté secondary cells charged by Daniell's cells—in other words, one or two Daniell's cells are constantly in action charging three or six Planté cells, and it is the Planté cells that are called into action to electrify the magnet. The battery is carried in a box in the brake van. The engineers, however, seem to prefer that the current be obtained by means of a small Gramme machine, driven direct by a Brotherhood three-cylinder engine, the steam for which is obtained from the locomotive. The velocity and hence the current of the Gramme machine can be regulated, and so the action of the brakes. M. Achard prefers the Planté cells; he informs us that he has tried the Faure battery, but the results obtained were not satisfactory. The regulator, R<sup>2</sup>, consists of a cylinder of wood around which, as shown, wire is wound. The length of this wire in the circuit, increasing as it does the resistance of the circuit, determines the current to the electro-magnet. The action is as follows: When it is necessary to apply the brakes, a simple pressure of a key or the turn of a handle sends the electric current into the wires of the electro-magnet. An attraction immediately takes place, and the poles and armatures are brought into contact. The friction between these causes the revolution of the magnet, the winding of the chain around the axle, and the application of the brakes. The whole of the



brakes of the train enter into action at one and the same time. The brakes are taken off by stopping the current, and a small spring pulls and keeps the magnet from the armatures. A frame—also carriages—fitted with this brake, are shown by the Compagnie des Chemins de Fer de l'Est, which company also shows several other pieces of interesting apparatus, one of which is a carriage fitted with elaborate mechanism, in which electricity plays, perhaps, but a subsidiary part, to obtain the traction of the train under varying circumstances, the pressure on the buffers when stopping, and various phenomena connected with the engine.—*The Engineer*.

---

## ELECTRICITY; WHAT IT IS, AND WHAT MAY BE EXPECTED OF IT.<sup>1</sup>

By JACOB REESE

In the consideration of this subject it is not my purpose to review the steps of discovery and development of electrical phenomena, but the object of this paper is an effort to explain what electricity is; and having done this, to deduce some reasonable conclusions as to what may be expected of it. And while I am profoundly sensible of the importance of the subject, and the difficulties attending its consideration, still with humble boldness I present this paper and ask for it a serious and careful consideration, hoping that the discussion and investigation resulting therefrom may add to our knowledge of physical science.

It is now a well established fact that matter, *per se*, is inert, and that its energy is derived from the physical forces; therefore all chemical and physical phenomena observed in the universe are caused by and due to the operations of the physical forces, and matter, of whatever state or condition it may be in, is but the vehicle through or by which the physical forces operate to produce the phenomena.

There are but two physical forces, *i.e.*, the force of attraction and the force of caloric. The force of attraction is inherent in the matter, and tends to draw the particles together and hold them in a state of rest. The force of caloric accompanies the matter and tends to push the particles outward into a state of activity.

The force of attraction being inherent, it abides in the matter continuously and can neither be increased nor diminished; it, however, is present in different elementary bodies in different degrees, and in compound bodies relative to the elements of which they are composed.

The force of caloric is mobile, and is capable of moving from one portion of matter to another; yet under certain conditions a portion of caloric is occluded in the matter by the force of attraction. That portion of caloric which is occluded (known by the misnomer, latent heat) I shall call *static caloric*, and that portion which is in motion, *dynamic caloric*.

The force of attraction, as I have said, tends to draw the particles of matter together and hold them in a state of rest; but as this force is inherent, the degree of power thus exerted is in an inverse ratio to the distance of the particles from each other. The effective force so exerted is always balanced by an equivalent amount of the force of caloric, and that modicum of caloric so engaged in balancing the effective force of attraction is static, because occluded in that work.

In solid or fluid bodies, where the molecules are held in a local or near relation to each other, the amount of static caloric will be in direct proportion to the effective force of attraction, but in gaseous bodies the static caloric is in an inverse ratio to the effective force of attraction; hence the amount of static caloric present in solid and fluid bodies will be greatest when the molecules are nearest each other, and greatest in gaseous bodies when the molecules are furthest apart.

Caloric, whether static or dynamic, is not phenomenal; therefore the phenomena of light, temperature, incandescence, luminosity, heat, cold, and motion, as well as all other phenomena, are due to the movement of matter caused by the physical forces. Thus we find that *temperature is a phenomenal measure of molecular velocity*, as we consider weight to be the measure of matter.

An increase of temperature denotes an increased molecular velocity, and this in solid and liquid bodies unlocks a portion of the static caloric and converts it into dynamic caloric, while an increased temperature of gases occludes additional caloric, thus converting dynamic into static caloric; and a reduction of molecular activity reverses this action. From this we see that a change of temperature either converts static to dynamic or dynamic to static caloric.

Thus we find that the amount of static caloric which a body possesses is in direct

relation to its temperature, but, as I have already explained, temperature is a phenomenal indication of molecular velocity, and as increased velocity separates the molecules to a greater distance, which reduces the effective force of attraction and unlocks a portion of caloric, it will be seen that the separation of the molecules from any other cause will have the same effect. I desire now to explain a second method by which the molecules are separated and static caloric is changed to dynamic caloric.

It is not definitely known how much static caloric is occluded in either of the elementary bodies, but it is believed that hydrogen possesses the greatest amount and oxygen the least. Now if we take a molecule of hydrogen containing two atoms, and under proper conditions interpose these atoms between 16 atoms of oxygen (one molecule), the phenomenon of combustion is exhibited, and a molecule of water is formed containing 18 atoms; and if one pound of hydrogen is thus consumed, the atoms of hydrogen are separated from each other to such a distance by the interposing atoms of oxygen as to unlock 34,662 units C. of static, and convert it into dynamic caloric. And if we thus bring a molecule of carbon containing 12 atoms in contact with a molecule of oxygen of 16 atoms, combustion ensues and a molecule of carbonic oxide of 28 atoms is formed, and if we then present another molecule of oxygen, combustion again takes place, and a molecule of carbonic acid, containing 44 atoms, is produced. Now, in the combustion of one pound of carbon in this manner, when the carbon is converted into carbonic oxide (CO), 2,473 units C. of static is converted into dynamic caloric; and when this CO is converted into carbonic acid (CO<sub>2</sub>) 5,607 additional units C. are unlocked. Thus by the combustion of one pound of carbon to CO<sub>2</sub>, 8,080 units C. of static caloric are changed to dynamic caloric.

When caloric is thus unlocked from its occlusion it escapes with great velocity until an equilibrium is attained, and in doing so it pushes the particles of matter out of its path. In solid bodies this produces such a high degree of molecular movement as to exhibit the phenomena of incandescence and luminosity, and in liquids increased mobility, while in gases the molecular activity may be so great as to produce the phenomena of sound and light; and the more rapidly combustion takes place the greater will be the volume and velocity of dynamic caloric escaping therefrom; consequently with a slow combustion, the phenomena produced by dynamic caloric will be different from those exhibited at a high degree.

Combustion, as I have before shown, is merely the oxidation of the material; nothing is *consumed* nor annihilated, and, the phenomena vary with the velocity of oxidation. Now, if we take one pound of zinc and place it in the acid cell of an electric battery, the oxygen of the acid attacks the zinc and oxide of zinc is formed. In this operation the Zn molecule containing 65 atoms is united with one molecule of oxygen of 16 atoms, forming a molecule of oxide of zinc (ZnO) of 81 atoms; and owing to the comparatively small number of oxygen atoms interposed between the 65 atoms of zinc, only 1,301 units C. of static caloric are unlocked to the pound of zinc, and the velocity of oxidation is so low, and the insulation of the vessel so perfect, that the dynamic caloric is caused to flow outward through the copper wire.

ELECTRICITY.—What is it? Why, it is dynamic caloric. Now let us take this oxide of zinc (ZnO) and place it with charcoal in a reducing apparatus which stands on an insulated table; the apparatus is then heated, the carbon vaporizes, and this vapor of carbon (C) robs the oxide of zinc (ZnO) of its oxygen, leaving metallic zinc (Zn) and carbonic oxide (CO). Now, for every pound of zinc so formed 1,301 units C. of static caloric are transferred from the charcoal to the zinc and occluded in it. Hence we find that the 1,301 units C. of caloric which we took out of the zinc, and which we call electricity, is nothing else but the 1,301 units of static caloric which was contained in the charcoal and from it set free by oxidation and transferred to the zinc in the smelting process. Let us follow this matter a little further. Charcoal is made by burning wood under such conditions as eliminate the water and hydrogen and leave the carbon as a residuum which we call charcoal. Thus we find that the caloric contained in the charcoal, transferred from the charcoal to the zinc, and from it developed into what we call electricity, was previously embodied in the wood; and if we study the laws of vegetation, we find that the atmosphere being charged with carbonic acid (CO<sub>2</sub>), the leaves of plants, shrubs, and trees, breathing, take in the CO<sub>2</sub>, the sun rays decompose the CO<sub>2</sub>, set free the oxygen, and supply the necessary amount of caloric for the condensed state of the carbon. Thus we find that the force which we term electricity, developed from the oxidation of zinc, or any other matter, by oxidation, primarily comes from the sun rays.

Coal is generally supposed to be of vegetable origin, and the caloric occluded in it is derived from the same source as that embodied in charcoal. Now when we burn coal under a steam boiler, the carbon and hydrogen are oxidized, and the static caloric set free. A portion of this caloric passes through the shell or tubes of the boilers, and increases the molecular velocity of the water; increased activity of the molecules tends to separate them to a greater distance from each other. When the molecular velocity of the water acquires the degree indicated by a temperature of 212 degrees

F., the water passes from the fluid to the gaseous state, and in doing so expands to 1,696 times its bulk. Now if the steam so developed be confined under a pressure of 105 pounds to the square inch, the water will not vaporize until a molecular velocity is attained indicated by a temperature of 312° F. (Spons' "Engineering," D2, page 418), and then the expansion is only 253 times its bulk. By using this steam, in a steam engine, the caloric in the steam tends to push the molecules of which it is composed into an ultimate expansion of 1,696 times the bulk of the water from which it was generated, and this force acts upon the piston and does the work. Thus we see that the steam engine is driven by the same force which produces the phenomena accredited to electricity.

I have already shown that in what we term combustion not a particle of the ponderable matter is annihilated. Combustion is but a phenomenon resulting from a rearrangement of the particles, and so it is with the imponderable physical force caloric; it is not consumed when light and heat are produced, nor converted into power, as we are sometimes told. But whatever the phenomena produced, the aggregate amount of static and dynamic caloric is always and ever the same.

If we consider the Ritter-Plant-Faure-Battery, which is mentioned as storing electricity, we find that the phenomena exhibited by the use of this apparatus are produced by the same factor. The battery is composed of two sheets of lead, which are covered with a layer of minium ( $Pb_3O_4$ ). The sheets are laid one upon the other with an intervening layer of felt. The pack is then rolled up in a spiral form and placed in a vessel containing acidulated water. One of the plates is connected with the positive, and the other plate with the negative pole of a battery or generator.

When the current of electricity enters the battery, the  $Pb_3O_4$  on the positive plate is reduced to Pb, and the oxygen so set free attacks the  $Pb_3O_4$  on the negative plate, and oxidizes it to  $PbO_2$ . In this chemical action, caloric is occluded in the Pb and unlocked in the  $PbO_2$ , but a much greater amount of caloric is locked up than is unlocked, although the amount of oxygen used in both cases is precisely the same, which has been fully explained in the oxidation of carbon.

Now after the battery has been thus charged and the wires disengaged, the chemical action ceases for want of the reducing agent (*dynamic caloric*), and the apparatus may be held at rest, or transported to any distance required. When it is desired to utilize the force thus stored, the poles are changed by grounding the positive wire, and attaching the other to the conduit through which the electricity is to flow. The chemical action is thus reversed, and the  $PbO_2$  is reduced to  $Pb_3O_4$ , the oxygen thus set free attacks the Pb on the other plate, oxidizing it to  $Pb_3O_4$ , thus unlocking all the caloric which was occluded by the first action. In a battery of this kind weighing 75 pounds, we are informed by Sir William Thomson, that one million foot pounds of force may be stored, and again set free for use.

Thus we find that the principle upon which the Faure battery is formed is not new, and the prime factor producing the phenomena is the same as has been shown to have caused all other phenomena referred to, and indeed the principle is the same as now employed by the author in the basic dephosphorizing process, *i.e.*, caloric is occluded in phosphorus by smelting in a blast furnace, and unlocked in the converter, for the purpose of securing the fluidity of the metal during treatment. The difference being, that one is done by non-luminous, while the other is by luminous combustion.

If we consider the phenomenon of light, we find that it is due to the same force. As before stated, when we oxidize carbon, or hydrogen, as in the rapid combustion of wood, oil, or coal, the escaping caloric flies off with such great speed as to cause the molecules in the circumambient medium to assume a velocity which exhibits luminosity. Thus the light produced by burning candles, oil, gas, wood, and coal, is caused by the same prime factor, dynamic caloric.

The force of caloric is imponderable and invisible, and is only known by its effects. We do know that it is occluded in metals and other material, because we can unlock it and set it free, or we can transfer it from one body to another, and by measuring its effects, we can determine its quantity. We know that it prefers to travel over one vehicle more than another, and by this knowledge we are able to insulate it, and thus conduct it in any direction desired. The materials through which it passes with the greatest freedom are called conductors, and the materials which most retard its passage, non-conductors; but these terms must be taken in a comparative sense only, as in fact there are no absolute non-conductors of dynamic caloric, or of what we call electricity.

The dynamo-electric generator simply draws the dynamic caloric from the air or earth, or both, and confines it in an insulated path. Now if that path be a No. 10 wire, the conduit may be sufficient to permit the caloric to pass without increasing the

molecular velocity of the metal to an appreciable degree, but if we cut the No. 10 wire and insert a piece of No. 40 platinum wire in the path, the amount of caloric flowing through the No. 10 wire cannot pass through the No. 40 wire, and the resistance so caused increases the molecular velocity of the No. 40 wire to such degree as to exhibit the phenomenon of incandescence, and this is the incandescent electric light. And if we consider the carbon light, we find that the current of caloric, in passing from one pencil to the other, produces a molecular velocity of luminosity in the adjoining atmosphere, and in addition a portion of the carbon is consumed, which sets free an additional amount of caloric, at a very high velocity, hence the intensity of the carbon electric light is largely due to the dynamic caloric unlocked from the pencils, and thus we find that the electric light produced by either method is due to the action of dynamic caloric.

Taking this theory based upon physical science, and the facts which we know pertaining to electricity, I conceive that caloric exists in two conditions. *Static caloric* is what we call *latent heat*, and *dynamic caloric* is what we call *electricity*. Therefore what may we expect of it (electricity) is merely a matter of economy in the development and utilization of dynamic caloric; in other words, can we unlock static caloric by non-luminous combustion, and thus develop *dynamic caloric as a first power* more economically per foot pound than we now do or can hereafter do by luminous combustion? Second, can we utilize water and wind for the production of *dynamic caloric as a first power*? Third, can we utilize the differential tension of dynamic caloric in the earth and the atmosphere as a *first power*? Fourth, will it pay to use luminous combustion as a first power to generate dynamic caloric as a *second power*?

### WHAT MAY WE EXPECT OF IT.

Let us take the steam engine, and see what we are now doing by luminous combustion. Good Pittsburg coal contains 87 per cent. of carbon, 5 per cent. of hydrogen, 2 per cent. of oxygen and 6 per cent. of ash; we therefore have in one pound of such coal:

$$\frac{8,080 \times 9}{5} = \frac{14,544 \times 87}{100} = 12,653 \text{ units in carbon.}$$

$$\frac{34,662 \times 9}{5} = \frac{62,391 \times 5}{100} = \frac{3,119}{15,772} \text{ units in hydrogen.}$$

$15,772 \times 772^2 = 12,175,984$  foot pounds of energy is occluded in the static caloric contained in one pound of such coal.

A horse-power is estimated as capable of raising 33,000 pounds one foot high per minute, and for this reason it is termed 33,000 foot pounds per minute. So we have  $33,000 \times 60 = 1,980,000$  foot pounds per hour, as a horse-power.

The best class of *compound condensing* engines,<sup>3</sup> with all the modern improvements, require 1.828 pounds of coal per 1 h.p. per hour. Thus we have—

12,175,984 × 1.828	22,257,699
Foot pounds in one h.p.	<u>1,980,000</u>
Foot pounds lost per h.p.	20,277,699
Per cent utilized per h.p.	8.94
Per cent lost per h.p.	<u>91.06</u>
	100.00

In the ordinary practice of stationary non-condensing engines, from three to four pounds of coal are required per horse-power per hour. Now, taking the best of this class at 3 pounds, we have—

12,175,984 × 3 =	36,527,952
One h.p.	<u>1,980,000</u>
Loss per h.p.	34,547,952
Per cent utilized per h.p.	5.42
Per cent lost per h.p.	<u>94.58</u>
	100.00

From these facts it may be assumed that after making due allowance for variable qualities of the coal, the steam engine process, as at present practiced, will not utilize more than from 5 to 10 per cent. of the energy contained in the fuel used. It will thus be seen that the process of converting static to dynamic caloric by luminous

combustion, by means of the steam engine, is an exceedingly wasteful and costly method, and leaves much room for economy.

Taking an ordinary grade of petroleum as consisting of 13 per cent. hydrogen, 78 carbon, 6 oxygen, 3 nitrogen and ash, we have as its energy in foot pounds per pound of oil—

$$\left. \begin{array}{l} \frac{62,391 \times 13}{100} = 8,110 \text{ H.} \\ \frac{14,544 \times 78}{100} = 11,344 \text{ C.} \end{array} \right\} 19,454 \text{ units.}$$

$19,454 \times 772 = 15,018,488$  foot pounds. Thus, while our best coal contains twelve million, the petroleum contains fifteen million foot pounds of occluded energy in each pound, which is equal to 118,000,000 foot pounds, or 60 horse power for one hour, from one gallon of such oil.

At present electricity is generated by two methods, and both of these are *second powers*. Metals are smelted by luminous combustion as a first power, and then oxidized by non-luminous combustion as a *second power*, and coal is consumed by luminous combustion, by which steam is generated as a first power, to drive a dynamo-generator whereby electricity is obtained as a *second power*. Now, of the two methods, the latter is much the cheaper, and as I have shown that the best compound condensing engines only utilize 8.94, and a fair average single cylinder condensing engine only utilizes 5.42 per cent. of the energy of the fuel consumed, and as at the best not over 70 per cent. of the foot pounds obtained from the engine can be utilized as electricity, from which we must deduct loss by friction, etc., it will be readily seen that not more than 5 per cent. of the energy of the fuel can be developed by the dynamo-generator as electricity by the present method.

The great want of the present age is a process by which the static caloric of carbon or a hydrocarbon maybe set free by non-luminous combustion; or, in other words, a process by which coal or oil may be oxidized at a low degree, within an insulated vessel; if this can be accomplished (and I can see no reason why we should not look for such invention), we would be able to produce from twelve to fifteen million foot pounds of energy (electricity) from one pound of petroleum, or from ten to twelve million foot pounds from one pound of good coal, which would be a saving of from 90 to 95 per cent. of present cost, and leave the steam engine for historical remembrance.

Electricity may be generated by water or wind power to great advantage, and conveyed to a distance for motive power. The practicability of generating electricity at Niagara by which to propel trains to New York and return may be considered almost settled; and I conceive a second invention of importance which is now needed is an apparatus by which the rising and falling tides may be utilized for driving dynamo machines, by which electricity may be generated for lighting the coast cities, and it is not unreasonable to expect that such an apparatus will soon be provided; and in such an event gas companies would suffer.

It is a well known fact among electricians that the volume and tension of electricity vary both in the earth and in the atmosphere at different sections of the earth's surface, and I conceive that we may yet find means of utilizing this differential tension of electricity; indeed, it is reported that during a recent storm the wires of an ocean cable were grounded at both ends and a sufficient current for all practical purpose flowed from the European to the American continent, with all batteries removed, showing that the tension was so much greater in Europe as to cause the electricity to flow through the copper cable to this side in preference to passing through the earth or the sea. It is also said that during an east-going storm it was found impossible to work the telegraph lines between New York and Buffalo, but on taking off the batteries at both ends and looping the ends of the wire in the air, that a constant current of electricity passed from Buffalo to New York, and the line was kept in constant use in that direction without any battery connection until the storm abated. Now, how far or to what advantage we may be able to utilize this differential tension of electricity in the earth and the air, we cannot now say; but I think that we may justly look for valuable developments in this direction.

If, as I verily believe, a process will soon be discovered by which dynamic caloric can be produced by the oxidation of petroleum with non-luminous combustion in an insulated chamber, as we now oxidize zinc, electricity will then be obtained from so small a weight, and at such a low cost, as to insure aerial navigation beyond a doubt. Not with balloons and their cumbrous inflations, but with machines capable of carrying the load, and traveling by displacement of the air at high velocities. Therefore we may expect that aerial navigation will be developed in the near future to be one of the greatest enterprises of the world.

And lastly, will it pay to use luminous combustion as a first power for generating dynamic caloric for use as a second power, as is now practiced?

At the University of Pennsylvania, in Philadelphia, gas is consumed in an Otto gas engine, which drives a Gramme generator; and the lecture room is lighted with electricity, and I am informed that the light is both better *and cheaper* than when they used the gas in the ordinary gas burners. Hence we may expect to see gas consumed to advantage for producing electric lights.

Considering the difficulties of transmitting steam power to a considerable distance, and the comparative great cost of running small engines, it is more than likely that electricity as at present generated will be found to be economical for driving small motors.

Having thus endeavored to explain what electricity is, and the laws which govern the occlusion of static caloric, and the development of dynamic caloric (electricity), in conclusion I call the attention of the inventors of the age to the great need of a process for oxidizing coal or oil at a low degree, within an insulated vessel. With such an invention electricity would be obtained at such a low cost that it would be used exclusively to light and heat our houses, to smelt, refine, and manipulate our metals, to propel our cars, wagons, carriages, and ships, cook our food, and drive all machinery requiring motive power.

[1]

A paper read before the Engineers' Society of Western Pennsylvania, Nov. 15, 1881.

[2]

Dr. Joule—foot pounds in one unit.

[3]

"American Engineer," Vol. II., No. 10, page 182.

---

## **ELECTRIC LIGHT APPARATUS FOR PHOTOGRAPHIC PURPOSES.**

**By A.J. JARMAN.**

For some time past it has been the desire of many photographers to have at hand a ready means of producing a powerful and highly actinic artificial light, suitable for the production of negatives, and easily controllable. Several forms of apparatus have been designed, and I believe have been, to a certain extent, employed successfully in portraiture. But it has been well known for many years that the electric light was just the light that would answer the photographer's requirements, owing to its possessing great actinic power; but the cost of its production was too great for general adoption; indeed, such might be said of it now as far as dynamo-electric machines and steam or gas motors are concerned, for the majority of photographers. It is true that several influential photographers have already adopted the use of the electric light for portraiture, but the primary cost of the apparatus employed by these firms is far beyond the reach of most portraitists. The apparatus about to be described is one that has been carefully worked out to meet the wants of the photographer in almost every particular; in fact, with this apparatus, portraits can, and have been, produced in an ordinary sitting room, as good and as perfect as if taken in a well-lighted studio.

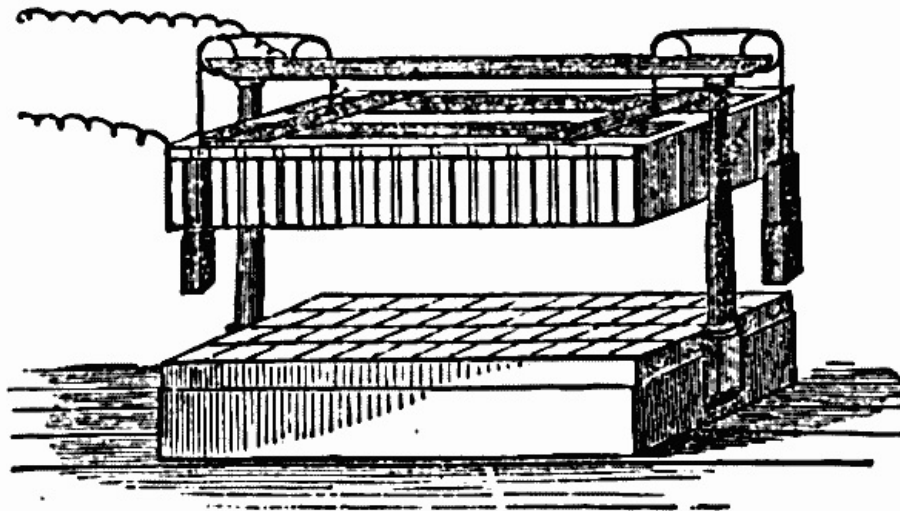

FIG. 1.

The generator of the electric current consists of a series of voltaic elements of zinc and carbon—forty-eight in number—these elements being made up of ninety-six zinc plates and forty-eight carbon plates; thus the generator consists of forty-eight voltaic elements arranged in rows of twelve; they are all carefully screwed upon suitable bars of wood, and these bars are joined by other cross bars, which bind the whole in a compact form; the battery being suitably connected so as to produce a current of very high electro-motive force, and so arranged over their exciting trough that the plates can be raised or lowered at will, as seen in Fig. 1, which will explain itself almost at first sight.

The troughs are made of mahogany, put together with brass screws, and well saturated with an insulating compound which also makes them acid proof; the cells are charged with a saturated solution of bichromate of potash, to which has been added twenty fluid ounces of sulphuric acid to each gallon.

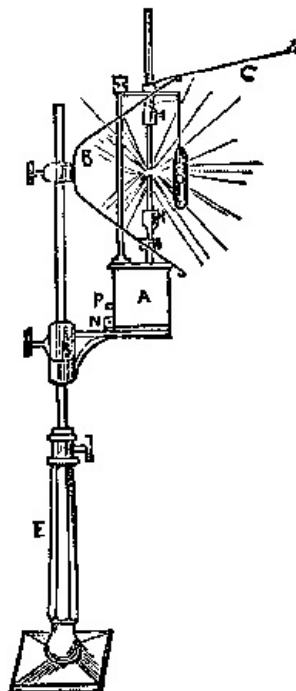

FIG. 2.

To produce the electric current, all that is needed is to lower these suspended elements down into the trough, having previously connected the wires as shown in Fig. 1, to the electric lamp, Fig 2. At once a light starts up, between the carbon pencils, of a thousand-candle power or more. With a light of this power, a large head on cabinet or carte size plate may be produced in three or four seconds.

The generator occupies a floor space of three feet six inches by two feet, and stands two feet six inches high. The cells will cost 5s. to charge, and will produce upward of sixty negatives before being exhausted. All that is necessary, in recharging, is to lift the elements up out of the way, take out the troughs by their handles and empty them, charging them again by means of a toilet jug. When replaced, the whole apparatus is fit for use again; the whole of the above operation occupies but a quarter of an hour, and as there are no earthenware cells employed, there is no fear of breakage.

The small amount of labor and cost of working the above apparatus will compare favorably with the production of the electric light from a dynamo-electric machine for the photographer, and when we consider that the cost of the whole of the above apparatus, consisting of a generator automatic lamp, reflector, and all the necessary appendages, is less than one-tenth of the dynamo machine, motor, shafting, etc., to produce the same result, it would seem to have a greater claim for its adoption with those who wish to employ the electric light, whether for work at night, use in the sitting room, or to assist daylight on the dark and foggy days of winter.

Fig. 2 shows the arrangement of the electric lamp. A is the automatic regulator; B, the reflector; C, top extension of the reflector; D, small tissue paper screen to prevent the intense arc-rays from coming in contact with the sitter; E, stand with sliding rod. This appendage can be wheeled about with ease, as it is arranged to run upon four casters.

When the generator is in use it may be placed within easy reach of the operator, so that the exposure may be made by lowering the elements in their troughs just for the requisite time, and withdrawing immediately the exposure is made; there is no need to fear any inconvenience from deleterious fumes as none are given off, so it may be used in any studio or sitting-room without any inconvenience from this source, and as far as many trials have gone, it seems to meet every requirement demanded by the photographer for the production of portraits by means of the electric light.—*Photo. News.*

---

## DESRUELLES'S ELECTRIC LIGHTER

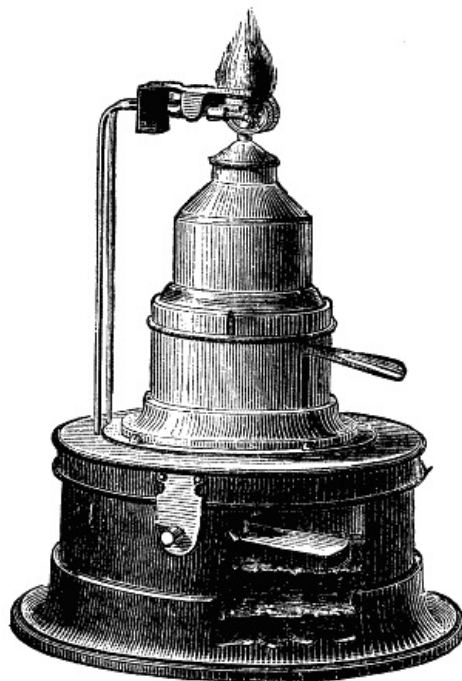

**ELECTRIC LIGHTER.**

The little apparatus shown in the accompanying cut will certainly find favor with smokers, as well as with persons generally who often have need of a fire or light. It forms one of the most direct applications of dry piles of all the systems on the Desruelles plan. Instead of filling piles with a liquid, this plan contemplates the introduction into them of a sort of asbestos sponge saturated with an acid or any suitable solution. In this way there is obtained the advantage of having a pile which is in some sort *dry*, that may be moved, shaken, or upset without any outflow of liquid, and which will prove of special value when applied to movable apparatus, such as portable lighters, alarms on ships, railroads, etc. It is hardly necessary to say that while the introduction of this inert substance diminishes the volume of the liquid, the electro-motive force of the pile is thereby in nowise affected, but its internal resistance is increased. This, however, is of no consequence in the application under consideration. The lighter consists of a small, round, wooden box containing the pile, and surmounted by a spirit lamp. A platinum spiral opposite the wick serves for producing the light. The pile is a bichromate of potash element, in which there is substituted for the liquid a solution of bichromate identical with that used in bottle piles. The zinc is suspended from a small lever, in which it is only necessary to press slightly to bring the former in contact with the asbestos paste, when, the zinc being attached, a current is set up which traverses the spiral, heats it to redness, and lights the spirit. The pile, when once charged, may be used for several hundred lightings. When the spiral no longer becomes red hot, it is only necessary to replace the paste—an operation of extreme simplicity. When the



pressure is removed from the little lever, the zinc, being raised, is no longer acted upon by the liquid with which the asbestos is saturated. Mr Desruelles is constructing upon the same principle a gas lighter, the pile of which is fixed at the extremity of a handle whose length varies with the height of the gas burners to be reached. These little domestic apparatus are being exhibited at the Paris Electrical Exhibition.

---

## SOLENOID UNDERGROUND WIRES IN PHILADELPHIA.

The *Evening Bulletin* of the 29th October has the following:

This afternoon a series of experiments were conducted at the Public Buildings which will be of great interest to electricians all over the country, and upon which the success of a number of underground telegraph projects in different parts of the United States depends. In all projects of this kind the problem which has given most trouble to inventors has been to overcome the induction. In other words, electric currents will leave their original conductors and pass to other conductors which may be near at hand. This interchange of currents may take place without seriously hindering ordinary telegraphy, as the indicators are not delicate enough to detect the induction. When telephones came into use, however, the induction became a great source of trouble to electricians, it often being the case that the sounds and influences from without were sufficient to drown out sounds in a telephone. To-day's experiment was conducted by Mr. J.F. Shorey, a well-known electrician, who exhibited Dr. Orazio Lugo's cables for electric light, telephone, and telegraphic purposes.

A large number of prominent electricians were present, including the following: General J.H. Wilson, President of the N.Y. and N.E. Railroad, of Boston; Messrs. Frank L Pope, S.L.M Barlow, George B. Post, Charles G. Francklyn, Col. J.F. Casey, W.H. Bradford, and Selim R. Grant, of New York; James Gamble, General Manager of the Mutual Union Telegraph Co.; T.E. Cornich and W.D. Sargent, of the Bell Telegraph Co.; S.S. Garwood and J.E. Zeublen, of the Western Union, and others.

The principal tests were made through the conduits on Market Street, laid by the National Underground Electric Company as far as Ninth Street. A cable of five conductors was laid through the conduit. Two of these conductors consisted of simple "circuit wires," while the other three were what is known as "solenoids." A solenoid wire is a single straight wire, connected at each end with and wound closely around by another insulated wire, this forming a complete system, the electric currents returning into themselves. Electricians claim that the solenoid effectually overcomes all induction, and this afternoon experiments were made for the purpose of proving that assertion. In the telephones, connected by the ordinary wires, a constant burr and click could be heard, that sound being the induction from the wires on the poles on Market Street, sixty feet overhead. With the solenoid the only sound in the telephones was the voices of the persons speaking. The faintest whispers could be heard distinctly, and the ease and comfort of conversation was in marked contrast to the other telephone on the ground wires. A set of telegraph indicators was also attached to the wires in use in the cable. The sounds were transferred from one "ground wire" to the other, while the solenoids seemed to resist every influence but that directed upon them by the operators. Another interesting test was made. The electric current for a Hauckhausen lamp was passed through a long coil of solenoid wire. Separated from this coil by a single newspaper, lay a coil of wire attached to telephones, yet not a sound could be heard in the telephones but the voices of the persons using them. The current of electricity created by a dynamo-electric machine is of necessity a violent one, and in the use of ordinary wires the induction would be so great that no other sounds could possibly be heard in the telephones.

---

## DR. HERZ'S TELEPHONIC SYSTEMS.

In an article by Count du Moncel, published in *SCIENTIFIC AMERICAN SUPPLEMENT*, No 274, page 4364, the author, after describing Dr. Herz's telephonic systems, deferred to another occasion the description of a still newer system of the same inventor, because at that time it had not been protected by patent. In the current number of *La Lumière Electrique*, Count Moncel returns to the subject to explain the principles of these new apparatus of Dr. Herz, and says:

I will first recall the fact that Dr. Herz's first system was based upon the ingenious use (then new) of derivations. The microphone transmitter was placed on a derivation from the current going to the earth, taken in on leaving the pile, and the different contacts of the microphone were themselves connected directly and

individually with the different elements of the pile. The telephone receiver was located at the other end of the line, and when this receiver was a condenser its armatures were, as a consequence of this arrangement, continuously and preventively polarized, thus making it capable of reproducing conversation.

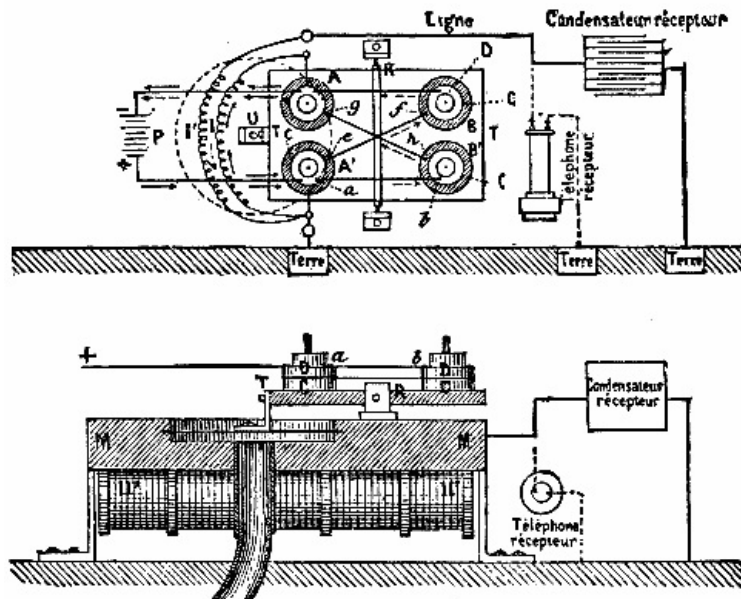

**DR. HERZ'S TELEPHONIC SYSTEMS.**

This arrangement evidently presented its advantages; but it likewise possessed its inconveniences, one of the most important of these being the necessity of employing rather strong piles and consequently of exposing the line to those effects of charge which react in so troublesome a manner in electrical transmissions when they occur on somewhat lengthy lines. Now the fact should be recalled that Dr. Herz's principal object was the application of the telephone to long lines, and he has been applying himself to this problem ever since. He at first thought of employing reversed currents, as in telegraphy; but how was such a result to be attained with systems based upon the use of sonorously-vibrating transmitters? He might have been able to solve the problem with the secondary currents of an induction bobbin, as Messrs. Gray, Edison, and others had done; but then he would no longer have been benefited by those amplifications which are furnished by the variations of pressure-derivations in microphones, and this led him to endeavor to increase the effects of the induced currents themselves by prolonging their duration, or rather by combining them in such a way that they should succeed each other, two by two, in the same direction; and this is the way he solved the problem in the beginning.

The fact should also be recalled that Dr. Herz had, from his first experiments, recognized the efficiency of those microphonic contacts that are obtained by the superposition of carbon disks or other semi-conducting substances. He has employed these under different arrangements and with very diverse groupings, but, as a general thing, it has been the horizontal arrangement which has given him the best effects.

Let us suppose, then, that four systems of contacts of this nature are arranged at the four corners of an ebonite plate, C C (Figs. 1 and 2), at A, A', B, B', and that they are connected with each other, as shown in the cuts—that is to say, the upper disks, e, f, g, h, parallel with the sides of the plate, and the lower disks, A, A', B, B', diagonally. Let us admit, further, that the plate pivots about an axis, R; that the disks are traversed by small pins fixed in the plate; and that small leaden disks rest upon the upper disks. Finally, let us imagine that the plate is connected at one end, through a rod T, with a telephone diaphragm. Now it will be readily understood that the vibrations produced by the diaphragm will cause the oscillation of the plate, C C, and that there will result therefrom, on the part of the disks, two effects that will succeed one another. The first will be, for the ascending vibrations, an increase of pressure effected between the disks of the left side, by reason of their force of inertia being increased by that of the lead disks; and the second will be, for the disks to the right, and, for the same reason, a reduction of pressure which will take place through resilience, at the moment of change in direction of the vibrating motions.

If the current from a pile, P, traverses all these disks, through the connections that we have just mentioned, and passes through the primary helix (through the wire, I) of an induction coil H H' (Fig. 2), located beneath the apparatus, and if the secondary current from this bobbin corresponds, through the wire I, with a telephone line in which there is interposed a telephone or a speaking condenser, there will be set up an inverse induced current, which, being reversed as a consequence of the crosswise connections of the disks, will continue the action of the first or increase its duration,

and, consequently, its force, through the telephone receiver.

The results of this system are very good; but Dr. Herz has endeavored to simplify it still further, and with this object in view has experimented on several arrangements. For example, to obtain inversion a contact was simply placed on each side of the vibrating plate. Although the movements of this latter are not, as we know, of the nature of ordinary sonorous vibrations, it was thought that they might prove to be in opposite directions on the two sides of the plate, and that one of the contacts might be compressed while the other was free. So notwithstanding the advantages of this arrangement, it was thought necessary to place the plate vertically in order to give the same regulation to the two contacts which it is essential should be identical. But it became difficult to regulate by weight; and even to succeed in regulating at all, it became necessary to employ two parallel diaphragms, vibrating in unison, and each carrying its contact, but in opposite directions. Afterwards, the horizontal arrangement was again adopted; but, by a clever combination, the two principles applied by Dr. Herz—derivation and inversion—were united. The current is then led to a double contact, where it divides. This contact is arranged under the plate in such a way that its two points of variable resistance act in opposite directions to each other, or, in some apparatus, so that one of the points has no variation, while the other is in action. The result that occurs may be easily imagined. The system has been experimented with under different forms; in one case the derivation is simple, that is, a single one of the currents being sent into the line, while in another case it is double, each of the branches being provided with a bobbin and communicating with the receiver. In the latter case the result is remarkably good, but the apparatus is not free from a certain amount of complication, and demands, moreover, particular care in its construction, experience having shown that the induction coils must not be equal, but that they must present resistances combined according to the circuit doing duty. It should be added that researches have been continued as to the bodies proper to be employed as microphonic contact, with the result of bringing out the important fact that the number of substances that can be put to this use is almost unlimited. The contacts of the Herz apparatus are now being made of conducting bodies (metals for example) reduced to powder and conglomerated by chemical means with a sort of non-conductive cement. The proportion of the elements depends upon the conductivity of the materials employed, and it alone determines the microphonic value of the compound, the nature of the elements apparently having scarcely any influence.

Nor has the speaking condenser been neglected. As regards this, efforts have seemingly been made toward finding a convenient arrangement and a regular mode of construction, the good working of these apparatus being absolutely dependent upon the care with which they are set up.

In Dr. Herz's opinion, the telephone is not to remain a single apparatus, varied only as to form, but, on the contrary, must be actually modified according to the purposes for which it is designed. He thinks that a telephone operating at great distances must differ from a city apparatus, and that an instrument for transmitting song can not be absolutely the same as one for conversational purposes. So he has endeavored to create types that shall prove appropriate for these different applications.

---

## DECISION OF THE CONGRESS OF ELECTRICIANS ON THE UNITIES OF ELECTRIC MEASURES.

For these measures there are adopted the fundamental unities—centimeter, gramme, second, and this system is briefly designated by the letters C., G., S. The practical units, the *ohm* and the *volt*, will retain their present definitions; the ohm is a resistance equal to  $10^9$  absolute unities (C., G., S.), and the volt is an electromotive force equal to  $10^8$  absolute unities (C., G., S.). The practical unit of resistance (ohm) will be represented by a column of mercury of 1 square mm. in section at the temperature of  $0^{\circ}\text{C}$ . An international commission will be charged with ascertaining for practice, by means of new experiments, the height of this column of mercury representing the ohm. The name *ampère* will be given to the current produced by the electromotor force of 1 volt in a circuit whose resistance is 1 ohm. *Coulomb* is the quantity of electricity defined by the condition that in the current of an ampère the section of the conductor is traversed by a coulomb per second. *Farad* is the capacity defined by the condition that a coulomb in a condenser, whose capacity is a farad, establishes a difference of potential of a volt between the armatures.

---

## SECONDARY BATTERIES.

By J. ROUSSE.

In order to accumulate electricity for the production of light or motive power, the author has arranged secondary batteries, which differ from those of M.G. Planté. At the negative pole he uses a sheet of palladium, which, during the electrolysis, absorbs more than 900 times its volume of hydrogen. At the positive pole he uses a sheet of lead. The electrolyzed liquid is sulphuric acid at one tenth. This element is very powerful, even when of small dimensions. Another secondary element which has also given good results, is formed at the negative pole of a slender plate of sheet-iron. This plate absorbs more than 200 times its volume of hydrogen when electrolyzed in a solution of ammonium sulphate. The positive pole is formed of a plate of lead, pure or covered with a stratum of litharge, or pure oxide, or all these substances mixed. These metallic plates are immersed in a solution containing 50 per cent. of ammonium sulphate. Another arrangement is at the negative pole, sheet-iron; at the positive pole a cylinder of ferro-manganese. The electrolyzed liquid contains 40 per cent. ammonium sulphate.

---

## THE TREATMENT OF QUICKSILVER ORES IN SPAIN.

Though known from remote times, the date of the first opening of the famous mines of quicksilver of Almadén has not been precisely determined. Almost all the writers on the subject agree that cinnabar, from Spain, was already known in the times of Theophrastus, three hundred years before the Christian era, although there is evidence in the writings of Vitruvius that they were worked at a still earlier date, Spanish ore being sent to Rome for the manufacture of vermilion. Such ore constituted a part of the tribute which Spain paid to Rome emperors, and there are records of its receipt until the first century after Christ. The history of Almaden during the reign of the Moors is so much involved in doubt that some writers deny altogether that the Arabs worked the deposit; still the very name it now bears, which means "the mine," and many of the technical terms still in use, give evidence that they knew and worked that famous deposit. As for their Christian conquerors, there are stray indications that they extracted mercury during the twelfth and thirteen centuries. In 1417, Almaden was given the privileges of a city, and from 1525 to 1645 the working of mines was contracted for by the wealthy family of Fugger, of Augsburg, Germany. Since then, the mine has been worked by the state, though the Rothschilds have controlled the sale of the product.

According to Vitruvius, the works for manufacturing vermilion from Spanish ore in Rome were situated between the temple of Flora and Quirino. The ore was dried and treated in furnaces, to remove the native mercury it contained, and was then ground in iron mortars and washed. In addition, small quantities of quicksilver and vermilion were made at Almaden. The ancients describe other methods, among which Theophrastus speaks of using vinegar, which, however, appears from modern investigations to have been an erroneous account. Nothing definite is known concerning the methods of the Moors; we possess only as a proof that they produced mercury, an account of a quicksilver fountain in the marvelous palace of Abderrahman III., at Medina-Zahara, and the works of Rasis, an Arab. The Moors probably extracted mercury at Almaden, from the eighth to the twelfth century, by the use of furnaces called "xabecas," which latter, in the fourteenth century, were still employed by the Christians, who continued them till the seventeenth century, when German workmen replaced them by "reverberatory" furnaces, which in turn were superseded in 1646 by aludel or Bustamente furnaces. There is an anonymous description of the working with xabecas as practiced at Almaden in 1543, and later accounts in 1557 and 1565. The ore was put into egg-shaped vessels with a lid, the mineral being covered over with ashes. The vessels were packed in a furnace heated with wood, about 60 pounds being used per pound of quicksilver made. This system was also applied at the Guancavelica mines, discovered in Peru in 1566, where the xabecas were abandoned in 1633, being replaced by the furnaces invented by Lope Saavedra Barba, which there were called "busconiles," while in Spain they were named Bustamente furnaces, and elsewhere aludel furnaces. They were introduced at Almaden thirteen years after their first use in Peru by Juan Alfonso de Bustamente, Barba and his son having been lost at sea on their way to the Peninsula. In 1876, there were at Almaden, at the works at Buitrones, twenty such aludel furnaces and two Idria furnaces. D. Luis de la Escosura y Morrogh, from whose work we take the above notes, has followed the historical details of the growth of Almaden closely, and from his account of the method of working in 1878 we take some data:

It is not an easy matter to explain the classification of the ore at Almaden. *Metal* is there called the richest mineral, composed of quartz impregnated with crystalline cinnabar. *Requiebro* are middlings of medium richness, *China* are smalls, and *Vaciscos* the finest ore. Besides native mercury, which the ores of Almaden contain in greater or smaller quantity, the most abundant mineral is cinnabar, which is always crystalline and is often crystallized. The ores have, besides, a small quantity of selenium and iron pyrites intimately mixed with the cinnabar. The gangue is quartz,

occasionally argillaceous and bituminous. The following are assays of some of the ores made by Escosura:

	Metal.		Requiebro.		Vaciscos.		China.	
	1	2	3	4	5	6	7	8
Cinnabar	29.1	21.2	13.3	10.2	5.1	2.8	1.2	0.86
Iron pyrites.	2.2	2.0	2.0	1.9	12.3	1.5	2.1	2.80
Bituminous matter	0.6	1.0	1.0	1.2	4.6	0.7	3.4	0.90
Gangue	67.5	74.8	82.1	76.5	77.5	93.3	90.2	93.50
Total	99.4	94.0	98.8	98.9	99.5	98.3	98.7	98.06
Quicksilver	25.05	18.28	11.47	8.64	4.40	2.41	1.03	0.75

It appears to be a difficult matter to determine the average percentage of the various grades of ore. In 1872, a commission classified and sampled a lot of 300 tons with the following results:

Grade.	No.	Quantity, kilos.	Per cent. mercury.	Average of grade.
Metal	1.	81,890	23.86	24.80
	2.	14,970	22.65	
Requiebro	3.	12,240	15.20	12.47
	4.	17,000	10.50	
China	5.	31,890	3.84	1.75
	6.	32,360	1.17	
	7.	28,960	0.10	
Vaciscos	8.	78,320	9.24	9.24

This general average of 12.28 per cent. of mercury is pronounced higher than the usual run of the ore, which, it is stated, does not go above 7 to 8.50 per cent.

The furnace in which the ore is treated is cylindrical, 2 meters in diameter, and 3.70 meters high from a brick grate, supported by three arches to the arched roof. At the level of the grate is a charging orifice, and near the roof are openings into two chambers, from the bottom of which extend 12 lines of aludels, clay vessels, open at both ends, the middle being expanded. The mouth of one fits into the back end of the one following, a channel being thus formed through which the fumes to be condensed are passed. The lines of aludels which are laid on the ground terminate in a chamber, and for half the distance between the furnaces and these chambers the ground slopes downward, while for the other it slopes upward. Two furnaces are always placed side by side, and the pair have from 1,100 to 1,150 aludels.

The operation is as follows: A layer of poor quartz is spread over the brick grate; this is followed by a layer of smalls, and then by a layer of still finer stuff, all of it being low grade ore. On top of this are piled two-thirds of the *china* of the charge on which the *metal* is put. Then follows a layer of *requiebro*, another lot of *china*, and finally the *vaciscos*, shaped into balls, the whole charge amounting to about 11½ tons, which is put in from an hour and a half to two hours by three men. The charging orifice is then closed, the aludels are luted, and everything made tight. The fires under the brick grate are lighted and kept going for twelve hours, during which time furnaces, charge, and condensing apparatus are heated up. During this period, the temperature in the condensing-chamber at the end of the line of aludels runs up 40 or 50 degrees Celsius, and some mercury, evidently part of the native quicksilver, is noticed in it.

The temperature of the aludels in the immediate vicinity of the furnaces is about 140 degrees C. During this period, the consumption of fuel is four parts to every part of quicksilver produced. At its close, the fire is drawn, and the second period begins. The air entering through the brick arch is heated to from 200 to 300 degrees by contact with the layer of poor stuff, the cinnabar is ignited, and its sulphur oxidized, and the quicksilver vaporized and, condensing in the aludels, flows toward the depression in the central portion of the line. The temperature goes on increasing, until, twelve hours after the beginning of this period, the thermometer shows 212 degrees C. at the first aludels. This lasts for 18 hours, and then the third or "cooling period" begins, which takes from 24 to 26 hours, and during the beginning of which the temperature in the furnaces still rises. It is then opened and cooled down. A very elaborate series of observations made on the temperatures of various parts of the condensing apparatus of the Almaden furnaces has shown that at the aludels nearest to them the heat increases steadily until it reaches 249 degrees C., 44 hours after the beginning of the operation; that in the middle of the line, at the depression, the maximum is 50 degrees 50 hours after starting the fires; and that at the end it does

not surpass 39 degrees. In the final condensing chamber, the temperature varied, running downward from 40 degrees during the heating period to 14 degrees, rising again to 29 degrees toward the close.

The loss of the quicksilver during the operation has been vary variously estimated, some stating that it is 50 per cent. and more, while others place it at 30 per cent. Escosura, in his work, gives the details of an operation checked by a royal commission in 1872, according to which the loss in working ore running 9.55 per cent. was only 4.41 per cent.—a loss which he considered inevitable. In 1806, two Idria furnaces were put up at Almaden, but the engineers are not favorably impressed with them. The first cost is stated to be more than ten times greater than that of an aludel furnace, while the capacity is only 50 per cent. greater. One pair of Idria furnaces in five years produced 120,000 kilogrammes of quicksilver, against 843,000 kilogrammes made by eight sets of the Bustamente furnaces, the cost per kilogramme of quicksilver being respectively 0.121 and 0.056 peseta.

---

## THE BALLOON IN AERONAUTICS.

While it is undoubtedly true that the discovery of the balloon has very greatly retarded the science of aerostation, yet, in my opinion, its field of usefulness as a vehicle for pleasure excursions, for explorations, and for scientific investigations, has not been fully developed for the want of certain improvements, the nature of which it is the object of this paper to point out. The improvement of which I am about to speak relates to the regulation of the buoyancy of the balloon. This is now done by throwing out ballast or by allowing some of the gas to escape—a method which necessitates the carrying of an unwieldy amount of sand and the expenditure of an unnecessary amount of gas.

From the fire balloon invented by the Montgolfier Brothers, in 1782, to the superior hydrogen balloon of M.M. Charles and Robert, no material advancement has been made, except the employment of coal gas, first suggested by Mr. Green. The vast surface presented to the wind makes the balloon unmanageable in every breeze, and the aeronaut can do nothing but allow it to float along with the current. This is a difficulty which has been partly overcome, as was seen at the recent Paris Electrical Exhibition; but no one will ever be able to guide it in a direction opposite to a current of air. The aeronaut must ever content himself in being able to float in the direction of the current or at certain angles to its course; but to do this even is a matter which has not been successfully accomplished. An inflated balloon would ascend too high unless several hundred pounds of ballast were used to weight it down. This ballast serves another purpose, it is desirable to maintain the balloon at a uniform distance above the earth's surface, and as the two per cent. daily waste of gas diminishes the buoyancy of the balloon, it must be kept from descending by throwing off a certain amount of sand. Again, the heat of the sun and the action of warm air currents cause at times the volume of gas to undergo a sudden expansion, and then to prevent the balloon from running too high, the gas must be allowed to escape from the valve. The gas, under these circumstances, must also be allowed to escape in order to prevent the balloon from bursting. Presently the balloon will pass through a colder current of air and sudden condensation takes place, and the balloon would sink unless more ballast were thrown off. This process continues until the aeronaut has neither ballast nor gas left.

Now, I suggest that a large balloon be made with the mouth closed, so that no gas can escape; and that it carry enough ballast to keep it, under an ordinary temperature, at a certain distance from the ground. A pipe must enter the mouth of the balloon, one end of which opens in its interior and the other end in a gas reservoir which lies in the "basket" or "car." As soon as the gas undergoes an expansion, and a certain amount of pressure is made in this reservoir, a valve opens and a whistle signals the moment when the force pumps must be set to work to pump the air out of the balloon into the large *number two* reservoir, the frame work of which forms the body of the car. Taking a certain amount of gas out of the balloon is equivalent to taking on more ballast, while by condensing this gas into a large reservoir, it is not allowed to escape, and when necessary can be sent back into the balloon and thus prevent the throwing off of ballast. Coal gas, under a certain pressure, becomes heavier than air (or at least equally heavy), and thus the gas pumped out of the balloon will of itself serve as ballast. This invention will enable the balloonist to keep himself at a uniform distance above the earth, will prevent the carrying of so much ballast and the expensive waste of gas, and will enable him to keep afloat at least ten times as long as by the old method. I have made a model and tested the above theory.

ELI C. OHMART.

North Manchester, Ind.

## ARTISTS' HOMES. NO. 12—MR. WILLIAM EMERSON'S HOUSE AT LITTLE SUTTON, CHISWICK.

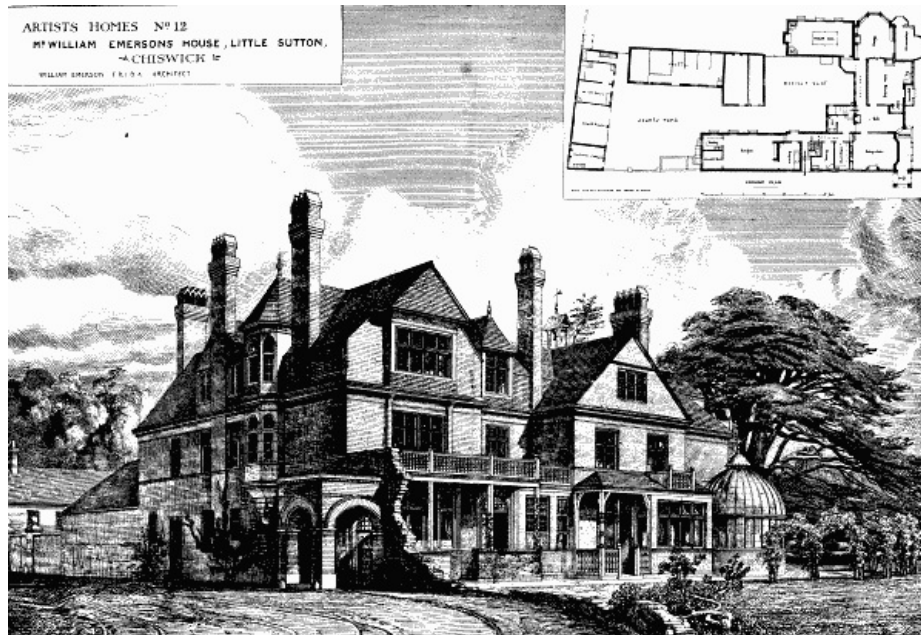

Little Sutton was an old house, parts of which were in existence before the time of Cromwell. It is situated in a picturesque old garden, surrounded by ivy-clad walls and fine trees, one of the cedars being extraordinarily large and perfect, its huge branches covering a space of over 90 ft. in diameter. The greater part of the old house, being uninhabitable through decay, was pulled down; the old parts are shown in black on the plan, and the new hatched. It is faced with red bricks, and red Corsehill stone dressings, and covered with tiles. The plan was arranged so as to preserve the old kitchen, billiard-room, morning room, and conservatory. The hall, entered from a veranda in connection with the entrance-porch, is surrounded by a dado, the height of doors; the lower panels are filled with tiles made to design by the School of Art at Bombay. The woodwork is painted a mottled blue color, harmonizing with the general tone of the tiles, the whole being something the color of *lapis lazuli*. The staircase is divided from the hall by three arches, through which is seen the staircase-window, representing, in stained glass, the Earth, Air, and Water. Under the central arch is the fireplace, on the hood of which will eventually be a bronze figure of Orpheus, on a ground of mosaic. The floor is of marble mosaic, and round the border are the various beasts listening to the music, the trees and river, etc. Above the dado, and on the wooden panels of ceiling, will be the birds, etc. The woodwork of dining-room is plain American walnut, the panels of dado being filled with dark Japanese leather-paper. The panels and beams of ceiling are of stained and dull varnished fir. The drawing room woodwork, and furniture throughout, is painted a mottled greenish blue, after the same manner as the hall. The decorations of this room, when complete, are intended to illustrate Chaucer's "House of Fame." The chimney-piece, of alabaster, is surmounted by a Caen-stone design, on a rock of glass, showing the entrance to the castle, with the various figures mentioned in the poem, carved in half-round relief, and the gateway itself also richly and quaintly carved; the rock of glass representing the ice on which the castle was supposed to be built, and on it are cut the various famous names of the world's history. In the frieze all round the room will be the figure of Fame and the various groups of suppliants, and the pillars with the groups upholding the renown of ancient cities and nations, etc., executed in very low relief, and painted on a ground of blue and gold. The panels of ceilings will have conventional designs and the heavenly bodies on ground of gold and blue. The morning and other rooms have no particular scheme of decoration prepared, and are simply painted and papered in quiet tones.



**ARTISTS' HOMES No. 12—LITTLE SUTTON, CHISWICK.**

We publish a longitudinal section, taken through the hall and drawing-room, with part of the dining-room on the left and part of the library on the right-hand side. The beautifully-modeled plaster frieze, with the central figure of Fame, is shown in the drawing-room, and illustrates Chaucer's "House of Fame," the whole being elaborately colored in harmony with the purposes and general tone of the room, which is in blue and gold. The hooded mantelpiece in the library is entirely in concrete, to be richly painted and gilded. The drawing, with the assistance of the description, will explain itself.—*Building News*.

## MEMORABLE ENGLISH HOUSES.

In the year 1864, a letter appeared in the *Journal of the Society of Arts* from a correspondent, who suggested that the Society of Arts should offer a prize or prizes for designs of memorial tablets to be affixed to houses associated with distinguished persons, and in the same year a series of suggested inscriptions was reprinted from the *Builder*. The subject having been brought under the notice of the council, a committee was appointed in 1866 to consider and report how the society might promote the erection of statues or other memorials of persons eminent in arts, manufactures, and commerce, and, at the first meeting of the committee, on May 7, Mr. George C.T. Bartley submitted some memoranda on the proposal to place labels on houses in the metropolis known to have been inhabited by celebrated persons. In 1837, the first tablet was erected by the society in Holles Street, Cavendish Square, on the house where Byron was born. Other tablets were soon afterward put up, and the erection of these memorials has been continued to the present time.

The house in Leicester Square, upon which a tablet in memory of Hogarth has been erected, is occupied by Archbishop Tenison's school, for which the house was rebuilt. The original building, in which Hogarth lived for several years, was long known as the "Sablonière Hotel." John Hunter lived next door after Hogarth's death. Of the four worthies who were intimately connected with Leicester Square, viz, Hunter, Hogarth, Newton and Reynolds, and whose busts are now set up at the four corners of the inclosure, the last three have tablets erected.

The house in St. Martin's Street, which is now occupied by the schools attached to the Orange Street Chapel, is in much the same condition as when Sir Isaac Newton lived in it, from 1710 to 1727, except that the old red bricks have been covered with stucco, and an observatory on the roof has been taken away within the last few years.





**NEWTON'S HOUSE, ST. MARTIN'S STREET.**

Flaxman had several London residences, but the house in Buckingham Street, Fitzroy Square, is the one with which he is most intimately associated, as he lived in it during the prime of his artistic career. He went there in 1796, when he returned from Rome, and there he died in 1826, being buried in the ground adjoining old St. Pancras Church and belonging to the parish of St. Giles-in-the fields. The house is on the south side of the street, close by Great Titchfield Street.



**FLAXMAN'S HOUSE, BUCKINGHAM STREET.**

Canning's house, on the south side of Conduit Street is greatly changed since the great statesman lived in it. It originally formed a wing of Trinity Chapel, which has been swept away within the last few years. This chapel was the successor of the chapel-on-wheels which was used at the Hounslow camp in the reign of James II., and was subsequently brought up to London. It is shown in Kip's view of old Burlington House as standing in the fields at the back of that house. When Conduit Street was built, a chapel was erected on the south side to supersede the chapel-on-wheels. The house on the west side of the chapel, where Canning lived for a time, was subsequently inhabited for many years by the famous physician, Dr. Elliotson, F.R.S. After his death, the front was altered, and a large shop window made, as seen in the accompanying figure. It is now in the possession of Mr. Streeter, the jeweler.



**CANNING'S HOUSE.**

Dr. Johnson had so many residences in London that there is some difficulty in choosing the one that is most interesting to us. The house in Gough Square has special claims to attention, as it was there that the great lexicographer chiefly compiled his dictionary. The garret, with its slanting roof, in which his amanuenses worked, and his own study are still to be seen. Johnson himself, in his "Life of Milton," observes, "I cannot but remark a kind of respect, perhaps unconsciously, paid to this great man by his biographers; every house in which he resided is historically mentioned, as if it were an injury to neglect naming any place that he honored by his presence." Emboldened by this expression of opinion, Boswell one evening, in the year 1779, ventured to ask Johnson the names of some of his residences, and he obtained the following list, which he printed in his "Life of Johnson:" (1) Exeter Street, off Catherine Street, Strand, (2) Greenwich; (3) Woodstock Street, near Hanover Square; (4) Castle Street, Cavendish Square, No. 6, (5) Strand; (6) Boswell Court; (7) Strand again; (8) Bow Street; (9) Holborn; (10) Fetter Lane; (11) Holborn again, (12) Gough Square; (13) Staple's Inn; (14) Gray's Inn; (15) Inner Temple Lane, No. 1; (16) Johnson's Court, No. 7; (17) Bolt Court, No. 8. In this last place he died in 1784.



**JOHNSON'S HOUSE.**

In April, 1879, the corporation of the city of London were asked to co-operate in this work, and to undertake the erection of suitable memorial tablets within the city boundaries. The matter was referred to the city lands committee, with which body the secretary has had several communications with respect to the localities suggested for memorials, the result being that the committee agreed to erect such

## DOMESTIC SUGAR PRODUCTION.

The value of sugar imported into the United States, is greater than that of any other single article of commerce. In the year 1880 it appears that over one thousand eight hundred and twenty-nine million pounds of sugar were brought here from other countries, at a cost of nearly one hundred and twenty million dollars, including customs duty. Moreover, the consumption of sugar, *per capita*, in this country is rapidly increasing. It was, during the ten years next preceding 1870, only 28 pounds on the average per annum, but, in the ten years next following, an average of 38 pounds per annum were consumed for each person of the population of this country. This appears to be an increase of 35 per centum in ten years.

The subject of domestic cultivation of sugar bearing plants is, therefore, one of great importance to this nation, and it has accordingly engaged the attention of the U.S. Commissioner of Agriculture, and many experiments have been made in different parts of the country in the propagation of the various canes, roots, etc., from which sugar can be made. Among sugar-bearing plants, beside the regular sugar cane, are, sorghum, sugar beet, maple, watermelon, sweet and white potato, and corn stalk.

Statistics show that of the 12,000,000,000 pounds of sugar produced in the world, about three-fourths comes from the sugar cane, and the other fourth comes mainly from the sugar beet. Of the total quantity, only about one seventieth is produced in the United States, and that is mainly cane sugar from Louisiana. The beet sugar has formerly been mainly produced in Europe. First France, second Germany, third Russia, then Belgium, Austria, Holland, Sweden, and Italy.

The consumption of sugar in Great Britain is much greater *per capita* than in the United States, about 65 pounds, or nearly double; while in Germany 19 pounds per annum are used on an average by each person, and in Russia the consumption is much less.

The importance of this subject to the United States, where the consumption of sugar is increasing out of ratio to the production of sugar-bearing plants, and where agricultural independence should be realized, as we have already attained and maintained political independence, and almost independence in manufacturing industries, has called out Mr. Lewis S. Ware, a member of the American Chemical Society, etc., in a pamphlet of over 60 pages, entitled a "*Study of the Various Sources of Sugar.*"

From this publication it appears that the main source of sugar supply must still be *sucrose*, cane sugar, even in spite of the best efforts of the general government and of the State agricultural organizations to introduce sugar-bearing plants that will thrive in the temperate and colder latitudes of this country. With the single exception of the sugar beet, he seems to disparage all attempts to produce practical sugar from hardy plants, or those that will mature in the region of frosts in winter. Even sorghum, that has for twenty years held a place in the hopes of the northern farmer, has declined so that the alleged production of half a million pounds in 1866 had become barely a twelfth of a million pounds in 1877.

In his remarks on the synopsis of one hundred and eleven experiments, made at Washington, he says: "As may be noticed, thirty-five of them (111) would yield zero. If we take the average of the hundred and eleven experiments, we find as a yield 4.5 per cent., which result cannot possibly be practically accepted. In other words, our government, notwithstanding the favorable conditions under which they were made, prove that the sorghum utilization is fallacy in every sense of the word." ... "If sorghum is to be grown for its sirup, or for fodder, it will evidently render excellent service." It seems that less than four per cent. of crystallizable sugar in the sorghum juice will not pay the cost of making sugar from it, as it will not crystallize in a reasonable time, on account of the glucose in the juice, which, with the other impurities, will prevent the ready crystallization of four or five times their own weight of *sucrose*.

From the early history of sorghum, it appears that it was known as *sorgo* in the sixteenth century, while twenty or thirty varieties were known under different names in Egypt, Arabia, and Africa. Some of the names are, Chinese sugar cane, (*sorgo*), India cane, *empee* or *Coffers' bread*, *paides anges*, etc.

The later history of it shows that in 1850, Count Montigny sent the first samples from China to Europe. It had been used in the former country for thousands of years for the manufacture of red dye. The seeds were afterward sold in France for a *franc* each.

A variety came later to this country from Africa, through the agency of an Englishman named Wray, to whom is charged the effects of the delusive experiments of trying to make crystallized sugar from its juice, which have been going on in this country for twenty years. But two varieties of sorghum now remain, known as the Chinese and African types. Of all the other sugar plants, none except the maple tree (besides the sugar cane and the beet) seem to have yielded sugar to pay the cost of manufacture. The maple tree has yielded a total of 41,000,000 pounds in 1877. But as an industry by itself, it appears to be unprofitable, and maple sugar must be, and generally is, sold at a higher price per pound than cane sugar; moreover, it has not the qualities that are required in a general sweetener for culinary purposes.

The variety of sugar plant called amber cane is not very clearly defined, but it may be taken, from the description of the juice as to crystallizing qualities, as no better sugar producer than sorghum. It, with sorghum, is classed as a sub-variety of sugar cane, which will yield sirup and fodder, but will not crystallize under several months' time, and even then in but small percentage.

On the whole it appears, as before stated, that the sugar beet is the only practicable source of sugar for the Northern States, which, as experimentally shown, can be raised at a profit of forty six dollars per acre, against twenty dollars per acre, the profit of sugar making from cane in Louisiana. Upon this showing several beet sugar factories have been started in the United States and in Canada, and their products are said to be satisfactory, and have been sold at a profit in competition with imported beet sugar.

Mr. Ware recommends the establishment of beet sugar factories on a larger scale, to be managed by men who have had experience in this particular kind of sugar making, which seems to be a practical means of supplying ourselves with home-made sugar. It must be remembered, however, that the successful cultivation of an ample supply of beets to keep them at work is an essential prerequisite.

---

## **HERALD ISLAND.**

John Muir, the geologist with the Corwin Arctic Expedition, describes, as follows, the characteristics of Herald Island, hitherto known only as an inaccessible rock seen by a few venturesome whalers and explorers:

After so many futile efforts had been made to reach this little ice bound island, everybody seemed wildly eager to run ashore and climb to the summit of its sheer granite cliffs. At first a party of eight jumped from the bowsprit chains and ran across the narrow belt of margin ice and madly began to climb up an excessively steep gully, which came to an end in an inaccessible slope a few hundred feet above the water. Those ahead loosened and sent down a train of granite boulders, which shot over the heads of those below in a far more dangerous manner than any of the party seemed to appreciate. Fortunately nobody was hurt, and all made out to get down in safety. While this remarkable piece of mountaineering and Arctic exploration was in progress, a light skin-covered boat was dragged over the ice and launched on a strip of water that stretched in front of an accessible ravine, the bed of an ancient glacier, which I felt assured would conduce by an easy grade to the summit of the island. The slope of this ravine for the first hundred feet or so was very steep, but inasmuch as it was full of firm, icy snow, it was easily ascended by cutting steps in the face of it with an ax that I had brought from the ship for the purpose. Beyond this there was not the slightest difficulty in our way, the glacier having graded a fine, broad road.

## **ON THE SUMMIT.**

Kellett, who discovered this island in 1849, and landed on it under unfavorable circumstances, describes it as an inaccessible rock. The sides are, indeed, in general, extremely sheer and precipitous all around, though skilled mountaineers would find many gullies and slopes by which they might reach the summit. I first pushed on to the head of the glacier valley, and thence along the back bone of the island to the highest point, which I found to be about twelve hundred feet above the level of the sea. This point is about a mile and a half from the northwest end, and four and a half from the northeast end, thus making the island about six miles in length. It has been cut nearly in two by the glacial action it has undergone, the width at this lowest portion being about half a mile, and the average width about two miles. The entire island is a mass of granite with the exception of a patch of metamorphic slate near the center, and no doubt owes its existence with so considerable a height to the superior resistance this granite offered to the degrading action of the northern ice sheet, traces of which are here plainly shown, as well as on the shores of Siberia and Alaska, and down through Behring Strait, southward, beyond Vancouver Island. Traces of the subsequent partial glaciation it has been subjected to are also

manifested in glacial valleys of considerable depth as compared with the size of the island. I noticed four of these, besides many marginal glacial grooves around the sides. One small remnant with feeble action still exists near the middle of the island. I also noted several scored and polished patches on the hardest and most enduring of the outswelling rock bosses. This little island, standing as it does alone out in the Polar Sea, is a fine glacial monument.

### **A MIDNIGHT OBSERVATION.**

The midnight hour I spent alone on the highest summit, one of the most impressive hours of my life. The deepest silence seemed to press down on all the vast, immeasurable, virgin landscape. The sun near the horizon reddened the edges of belted cloud bars near the base of the sky, and the jagged ice boulders crowded together over the frozen ocean stretching indefinitely northward, while more than a hundred miles of that mysterious Wrangell Land was seen blue in the northwest—a wavering line of hill and dale over the white and blue ice prairie and pale gray mountains beyond, well calculated to fix the eye of a mountaineer; but it was to the far north that I ever found myself turning, where the ice met the sky. I would fain have watched here all the strange night, but was compelled to remember the charge given me by the captain, to make haste and return to the ship as soon as I should find it possible, as there was ten miles of shifting, drifting ice between us and the open sea.

### **PLANT LIFE ON HERALD ISLAND.**

I therefore began the return journey about one o'clock this morning, after taking the compass bearings of the principal points within sight on Wrangell Land, and making a hasty collection of the flowering plants on my way. I found one species of poppy, quite showy, and making considerable masses of color on the sloping uplands, three or four species of saxifrage, one silene, a draba, dwarf willow, stellaria, two golden compositæ, two sedges, one grass, and a veronica, together with a considerable number of mosses and lichens, some of them quite showy and so abundant as to form the bulk of the color over the gray granite.

### **INHABITANTS OF THE CLIFFS.**

Innumerable gulls and murrens breed on the steep cliffs, the latter most abundant. They kept up a constant din of domestic notes. Some of them are sitting on their eggs, others have young, and it seems astonishing that either eggs or the young can find a resting place on cliffs so severely precipitous. The nurseries formed a lively picture—the parents coming and going with food or to seek it, thousands in rows standing on narrow ledges like bottles on a grocer's shelves, the feeding of the little ones, the multitude of wings, etc.

---

M. Bouchut's experiments with pepsine for destroying worms in the stomach and bowels have been continued with extremely promising results. Even the tapeworm succumbs to the digestive action of pepsine in large doses, while the more highly organized tissues of the stomach are unaffected.

---

### **FRANZ LISZT.**

On the 22d day of October, 1811, Franz Liszt, the greatest pianist of the last half century, was born at Raiding, in Hungary, and the entire musical world was united in celebrating his seventieth birthday, which took place this year.

What can be more appropriate than to take a look at the past and recall some of the important events of Liszt's so very interesting life? To recall his first appearance as a "wonder" child in his native town, the blessing and kiss he received a few years later from the immortal Beethoven, his great triumphs in the Paris salons and the defeat of his rival Thalberg. After the appearance of the violin virtuoso Paganini, he resolved to attain the highest development of his musical genius and to become so world-renowned as none has been before him, and in this was successful. He has not only maintained his standing as the greatest master of modern piano virtuosos, but has had the greatest influence on his followers and scholars, Taussig, v. Bulow, Mr. and Mme. Bronsart, Menter, and other younger and older pianists who have had the benefits of his instruction for a greater or less length of time, so that it can be justly claimed that the majority of our present virtuosos owe their success and fame directly or indirectly to the abilities of Liszt.

Liszt is endowed with that great gift of treating every individual in the manner most favorable to the development of its traces of artistic ability and desires, and this accounts for his wonderful results as instructor and master.



**FRANZ LISZT.**

But no picture of Liszt would be perfect without a *résumé* or recapitulation of his compositions.

After a most perfect transposition and preparation of numerous works of Beethoven, Schubert, and Berlioz, and after making their compositions popular and introducing numerous valuable novelties in the art of playing piano, he produced his "Symphonische Dichtungen" (Symphonic Poems).

These highly dramatic compositions, in which he follows Berlioz and often produces the most astonishing effects of sounds, however, did not find entire approbation with the public, and did not succeed in popularizing themselves. But that fact can be recorded in his favor that every programme containing Liszt's "Dante," or Faust Symphony, or "Mazeppa," receives more than ordinary attention from the public. The same is the case with his solo songs with piano accompaniment, in which, however, ingenious details often tend to drown the original melody. Of his quartets, some have become highly popular with singing societies and form part of their *repertoire*. The crowning point of Liszt's compositions is to be found in sacred music, for instance in his mass known as the "Grauer Messe," composed for the dedication of the Cathedral at Grau, in Hungary; the Crowning mass, and his two oratorios, "Die heilige Elisabeth" and "Christus." But even they caused a decided difference of opinion; and if some knew no bounds for their enthusiasm, others could not find an end for their condemnation. Such works should not be treated too lightly, and a thorough and impartial examination will show that a place of honor must be accorded to them in the history of music. Since the "Heilige Elisabeth" has been produced in several cities of Germany it has been viewed more favorably and disarmed many of the opponents.

But Liszt also belongs to the literary fraternity, and his works, published by Breitkopf & Hartel, contain some of the best ever written in regard to art and artists. They were mostly written in elegant French originally, and relate to the social position of artists and the state of the art of music in certain cities or even an entire country. A part of his works is devoted to the music of gypsies, and to a true and honest history of the life of his friend Chopin.

Then again we find him preparing the path to the hearts of the public for Berlioz, Schumann, Wagner, Robert Franz, and Meyerbeer. Liszt has certainly collected enormous sums of money in his successful career, but as fast as he reaps his earnings he gives them to those needing assistance, and it is almost entirely to him that the inhabitants of Bonn, on the Rhine, owe their beautiful Beethoven Monument, and during the last years Liszt has been untiring in giving concerts and collecting money for a monument for the greatest of the great, Johann Sebastian Bach.

Liszt is an artist in every sense of the word, and we should all wish that he will remain among us for many years more.

---

**M. GARNIER'S NEW METHODS OF  
PHOTOENGRAVING.**

In one of the upper rooms of the Electrical Exhibition in Paris, there is an interesting collection of plates and proofs produced by various methods of photo-engraving, invented by M. Henri Garnier, whose name is so well known in connection with these processes, and whose beautiful plate of the Chateau of Maintenon gained for him a gold medal at the Paris International Exhibition of 1867.

Some interesting details of these processes are given in an extract from a report on them by M. Davanne to the Société d'Encouragement pour l'Industrie Nationale, read at its sitting on the 22d July last, of which copies are distributed gratis in the exhibition.

The report opens with a brief allusion to M. Garnier's continuous labors in permanent photographic printing, commencing with the ingenious mercury process worked out in conjunction with M. Salmon, and published in 1855, in which a print which has been exposed to the fumes of iodine is laid down on a plate of polished brass, so that the iodine, absorbed by the printed lines, slightly attacks the brass; mercury being then rubbed over the brass, forms an amalgam with the iodized parts. If a roller charged with printing ink be now passed over the plate, the ink will only be taken on the pure brass, and not on the iodized parts. The plate is next bitten with acid nitrate of silver, and may then be treated in various ways, so as to form either a printing-block or an engraved plate. The process never came to any practical use, but led M. Garnier to the invention of the very valuable and largely used process of acierage or steel-facing, by which the surface of engraved copper-plates is so hardened and protected by a thin coating of iron that instead of only a few hundred impressions, many thousands can be printed from a plate without the slightest deterioration.

The next invention noticed is the citrate of iron process of M.M. Salmon and Garnier, in which a paper, coated with a sirupy solution of citrate of iron, is exposed to light under a positive print for a period varying from eight to ten minutes in the sun, to half or three-quarters of an hour in the shade. In the parts where the light has acted the paper becomes non-hygroscopic in proportion to the intensity of the action of the light upon it. The paper being left for a short time to absorb moisture from the air, is dusted over with lamp-black, which, attaching itself to the unexposed parts, reproduces an exact image of the original drawing.

M. Garnier has since greatly modified this method of obtaining an image by dusting, and applied it to various processes of photo-engraving.

The report then proceeds to give the following details of a process of photo-engraving, which was exhibited before the society by M. Garnier in March last:

### PHOTOGRAVURE.

In photo-engraving a distinction must always be made between the reproduction of drawings in line and those with shaded tints.

A.—*Photo-engraving of Line-work.*—A plate of copper is prepared by covering it, either by flowing or with a roller, with a very thin coating of a solution of:

Sugar 2 grammes. Bichromate of ammonia 1 gramme. Water 14 grammes.

This coating is equalized and quickly dried by means of an arrangement which keeps it in rotation over a warm plate.

As soon as the plate is dry, a positive cliché of the drawing to be reproduced is laid upon it, and the whole exposed to the sun for a minute, or to the electric light for three minutes. The reaction produced is the same as with the citrate of iron, but much quicker; the exposed parts are no longer hygroscopic, but in the parts protected by the lines of the drawing the sensitive coating has retained its stickiness, and will hold any powder that may be passed over it, thus producing a very clear image of the drawing. The coating being excessively thin, the little moisture it holds and the powder applied suffice to break its continuity, especially if the powder be slightly alkaline. If the rest of the surface were sufficiently resisting, the plate might be bitten at once; but light alone is not enough to produce complete impermeability: the action of heat must be combined with it. The plate is, therefore, placed on a grating, with wide openings, a large flame is applied underneath, and it is heated till the borders where the copper is bare show iridescent colors. The sugary coating thus becomes very hard in the exposed parts, but under the powder it is broken, porous, and permeable to acids. The surface is then covered with the biting fluid, which is a solution of perchloride of iron at 45° Baumé, and after few minutes' contact the plate is engraved. It only remains to clear off the bichromated sugary coating which forms the reserve, and which, being hardened by the heat, resists ordinary washing. It is removed perfectly by rubbing the surface with a hard brush and warm potash lye;

the plate is then ready for printing. Sometimes it may be necessary to give several successive bitings, or to use a resinous grain; in such cases the various methods of the engraver's art are employed.

B.—*Photo Engraving for Half-Tones.*—To reproduce by engraving the image of any object, a portrait, or a landscape, the gradation of tint is obtained by repeating three times in the following manner the operation A, just described:

The copper plate being prepared as before, it is exposed to the light under a positive, and given a long exposure, say four minutes, in the electric light. The sugary coating hardens under the whites and the lighter shades—it only remains tacky under the blacks. The positive cliché is removed, the plate powdered, and bitten; the blacks alone come out.

The plate is cleaned, then coated again with the sugary preparation, and exposed a second time under the positive, care being taken to preserve an accurate register, which may easily be done. The second exposure is not so long as the first—say two minutes, and gives the image of the middle tints and blacks. The plate is powdered and bitten as before, bringing out the middle tints, and, at the same time, giving greater depth to the shadows.

In the third operation, the plate is exposed still less to the light—say one minute. The high-lights alone harden; the light shades, middle tints, and the shadows remain permeable. After powdering and biting, the plate is finished.

When necessary, after each operation, a resinous grain may be applied in the manner usual with engravers.

It is important to note that M. Garnier affirms that in both cases the engravings are untouched, and that this is one of the essential characteristics of his process.

C.—*Engraving in Relief for Letter-Press.*—In the case of drawings in lines to be made into printing-blocks for letter-press printing, the operation is conducted in its first phase absolutely in the same manner as the foregoing, only, after exposure, instead of producing the image with a slightly alkaline powder, powdered bitumen is used, and the plate is slightly warmed, so that the powder may slightly fuse and adhere to the metal, but not enough to make the bichromated sugar become insoluble. The plate is then washed with water, and all the sugary coating removed, leaving the surface of the copper bare, except where it is protected by the bitumen forming the image. The plate is then bitten with perchloride of iron, which gives a first biting, leaving all the lines in relief. Further depth is obtained by alternate inkings and bitings, as in the Gillotype method.

The above processes are very interesting, the use of the sugary coating, the hardening it by heat, and the triple exposure and biting are new—at any rate, have not, so far as I know, been published before.

The report then goes on to describe a further application of the same principle to obtaining photographic images recently invented by M. Garnier, and called by him atmography.

### **PHOTOGRAPHIC PRINTING BY VAPOR—ATMOGRAPHY.**

This process consists in tracing or transferring by means of vapors or fumes an image of any object from one surface to another, whence the name of atmography it is proposed to give it. The operations are as follows:

When an image formed of a powdery substance has been obtained either by dusting (as described above), or by filling an engraved plate with the powder, the plate bearing the image is exposed to a vapor, which has no effect upon it. The powder alone absorbs the vapor, and if the plate be then applied to a surface coated with some substance capable of being acted upon by the vapor, an image is obtained upon this second surface. For example, the lines of an engraved copper-plate are filled with powdered albumen. On the other hand, a few drops of hydrofluoric acid are spread over a wooden board, and the powdered engraving is exposed for ten to fifteen seconds to the fumes disengaged by holding it about a quarter-of-an-inch above the board. The acid is absorbed by the powdered albumen without attacking the copper. If this plate be now placed in close contact with any surface (metal, paper, or glass) which has been covered with a coating of sugar and borax, and dried immediately, a deliquescent fluoborate of soda is produced under the action of the acid vapors, the sugar becomes tacky, and, by brushing a powder over this surface, the image appears immediately.

In M. Davanne's opinion this new invention of M. Garnier's seems likely to have a useful and extended application. The image may be made with powder of any desired color. If it is on glass, it may be transferred to paper or other support by means of



collodion or gelatine. By employing enamel powders, this process gives a new method of producing vitrified images. It may also be used as a simple method of reproducing engravings under certain circumstances; copies of diagrams, however intricate, could easily be produced on glass by it, and used for the illustration of lectures by means of the magic lantern.—*Photo. News.*

---

## DANGERS OF PYROGALLIC ACID.

By DR. T.L. PHIPSON.

Some time ago, Dr. Napias, of Paris, who devotes much of his time to matters connected with hygiene, took up the subject of the hygiene of the photographer, and published in the *Moniteur de la Photographie* a series of papers which were afterward translated into English and published by Messrs. Piper & Carter, of London. In them the worthy author has considered the action on the economy of the various poisonous substances which pass daily through the hands of our readers, and the best means of counteracting their influence.

Since then—in fact, quite recently—attention has been called in the medical journals to certain properties of pyrogallic acid which were perfectly unknown, and show that this substance, even when applied externally, may act as a violent poison causing death by its great affinity for oxygen. I published a short note upon the subject in the *Journal of Medicine*, etc., for April last, and it may perhaps be useful to reproduce the facts here. Physicians who were unacquainted with this energetic deoxidizing property of pyrogallic acid have proposed it as a substitute for chrysophanic acid in the treatment of skin diseases; but Dr. Neisser has made known a case of poisoning by an ointment of pyrogallic acid, which at once shows that considerable danger attends its use for this purpose. A man of strong constitution was admitted into one of the wards of the Breslau Hospital to be treated for general psoriasis. He appears to have been submitted to a kind of experimental treatment in order to test the curative properties of pyrogallic acid as compared with chrysarobine. He was treated by friction with chrysarobine (in the form of a pomade of alcoholic extract of rhubarb, containing one-twentieth) on the one-half of the body, while the other half was treated in the same manner by a pomade containing ten per cent. of pyrogallic acid. Six hours after the application the patient had violent shivering with vomiting and intense collapsus. Death occurred on the fourth day. Experiments were at once undertaken on rabbits, and proved that this catastrophe was due entirely to the pyrogallic acid pomade, and that the chrysarobine was innocuous. In some instances the rabbit died within two hours. It was also found that in the case of the patient in the Breslau Hospital the pyrogallic acid had acted by its extreme avidity for oxygen when in contact with alkaline fluids. The blood had been affected, and the red corpuscles were destroyed and turned brown. Very little urine was voided, but it presented a most extraordinary character, being dark brown and very thick; it contained no blood corpuscles, but a considerable amount of hæmoglobine (the coloring matter of the corpuscles), which was recognized by the absorption bands it gave in the spectroscope. The kidneys were uniformly bluish black. The blood had a dirty brownish red tint, and contained an abundance of *detritus* of red corpuscles.

This case points out once more that photographers cannot use too much prudence in dealing with chemical products which are in daily use by them, and the noxious properties of which, they are apt to forget.—*Photo News.*

---

A CATALOGUE, containing brief notices of many important scientific papers heretofore published in the SUPPLEMENT, may be had gratis at this office.

---

THE

## Scientific American Supplement.

PUBLISHED WEEKLY.

Terms of Subscription, \$5 a Year.

Sent by mail, postage prepaid, to subscribers in any part of the United States or Canada. Six dollars a year, sent, prepaid, to any foreign country.

All the back numbers of THE SUPPLEMENT, from the commencement, January 1, 1876, can be had. Price, 10 cents each.

All the back volumes of THE SUPPLEMENT can likewise be supplied. Two volumes are issued yearly. Price of each volume, \$2.50, stitched in paper, or \$3.50, bound in stiff

covers.

Combined Rates—One copy of *SCIENTIFIC AMERICAN* and one copy of *SCIENTIFIC AMERICAN SUPPLEMENT*, one year, postpaid, \$7.00.

A liberal discount to booksellers, news agents, and canvassers.

**MUNN & CO., Publishers,  
37 Park Row, New York, N.Y.**

---

## PATENTS.

In connection with the **Scientific American**, Messrs. MUNN & Co. are Solicitors of American and Foreign Patents, have had 35 years' experience, and now have the largest establishment in the world. Patents are obtained on the best-terms.

A special notice is made in the **Scientific American** of all Inventions patented through this Agency, with the name and residence of the Patentee. By the immense circulation thus given, public attention is directed to the merits of the new patent, and sales or introduction often easily effected.

Any person who has made a new discovery or invention can ascertain, free of charge, whether a patent can probably be obtained, by writing to MUNN & Co.

We also send free our Hand Book about the Patent Laws, Patents, Caveats, Trade Marks, their costs, and how procured, with hints for procuring advances on inventions. Address

**MUNN & CO., 37 Park Row, New York.**  
Branch Office, cor. F and 7th Sts., Washington, D.C.

\*\*\* END OF THE PROJECT GUTENBERG EBOOK SCIENTIFIC AMERICAN  
SUPPLEMENT, NO. 312, DECEMBER 24, 1881 \*\*\*

Updated editions will replace the previous one—the old editions will be renamed.

Creating the works from print editions not protected by U.S. copyright law means that no one owns a United States copyright in these works, so the Foundation (and you!) can copy and distribute it in the United States without permission and without paying copyright royalties. Special rules, set forth in the General Terms of Use part of this license, apply to copying and distributing Project Gutenberg™ electronic works to protect the PROJECT GUTENBERG™ concept and trademark. Project Gutenberg is a registered trademark, and may not be used if you charge for an eBook, except by following the terms of the trademark license, including paying royalties for use of the Project Gutenberg trademark. If you do not charge anything for copies of this eBook, complying with the trademark license is very easy. You may use this eBook for nearly any purpose such as creation of derivative works, reports, performances and research. Project Gutenberg eBooks may be modified and printed and given away—you may do practically ANYTHING in the United States with eBooks not protected by U.S. copyright law. Redistribution is subject to the trademark license, especially commercial redistribution.

START: FULL LICENSE  
THE FULL PROJECT GUTENBERG LICENSE  
PLEASE READ THIS BEFORE YOU DISTRIBUTE OR USE THIS WORK

To protect the Project Gutenberg™ mission of promoting the free distribution of electronic works, by using or distributing this work (or any other work associated in any way with the phrase "Project Gutenberg"), you agree to comply with all the terms of the Full Project Gutenberg™ License available with this file or online at [www.gutenberg.org/license](http://www.gutenberg.org/license).

### **Section 1. General Terms of Use and Redistributing Project Gutenberg™ electronic works**

1.A. By reading or using any part of this Project Gutenberg™ electronic work, you indicate that you have read, understand, agree to and accept all the terms of this license and intellectual property (trademark/copyright) agreement. If you do not agree to abide by all the terms of this agreement, you must cease using and return or destroy all copies of Project Gutenberg™ electronic works in your possession. If you paid a fee for obtaining a copy of or access to a Project

Gutenberg™ electronic work and you do not agree to be bound by the terms of this agreement, you may obtain a refund from the person or entity to whom you paid the fee as set forth in paragraph 1.E.8.

1.B. “Project Gutenberg” is a registered trademark. It may only be used on or associated in any way with an electronic work by people who agree to be bound by the terms of this agreement. There are a few things that you can do with most Project Gutenberg™ electronic works even without complying with the full terms of this agreement. See paragraph 1.C below. There are a lot of things you can do with Project Gutenberg™ electronic works if you follow the terms of this agreement and help preserve free future access to Project Gutenberg™ electronic works. See paragraph 1.E below.

1.C. The Project Gutenberg Literary Archive Foundation (“the Foundation” or PGLAF), owns a compilation copyright in the collection of Project Gutenberg™ electronic works. Nearly all the individual works in the collection are in the public domain in the United States. If an individual work is unprotected by copyright law in the United States and you are located in the United States, we do not claim a right to prevent you from copying, distributing, performing, displaying or creating derivative works based on the work as long as all references to Project Gutenberg are removed. Of course, we hope that you will support the Project Gutenberg™ mission of promoting free access to electronic works by freely sharing Project Gutenberg™ works in compliance with the terms of this agreement for keeping the Project Gutenberg™ name associated with the work. You can easily comply with the terms of this agreement by keeping this work in the same format with its attached full Project Gutenberg™ License when you share it without charge with others.

1.D. The copyright laws of the place where you are located also govern what you can do with this work. Copyright laws in most countries are in a constant state of change. If you are outside the United States, check the laws of your country in addition to the terms of this agreement before downloading, copying, displaying, performing, distributing or creating derivative works based on this work or any other Project Gutenberg™ work. The Foundation makes no representations concerning the copyright status of any work in any country other than the United States.

1.E. Unless you have removed all references to Project Gutenberg:

1.E.1. The following sentence, with active links to, or other immediate access to, the full Project Gutenberg™ License must appear prominently whenever any copy of a Project Gutenberg™ work (any work on which the phrase “Project Gutenberg” appears, or with which the phrase “Project Gutenberg” is associated) is accessed, displayed, performed, viewed, copied or distributed:

This eBook is for the use of anyone anywhere in the United States and most other parts of the world at no cost and with almost no restrictions whatsoever. You may copy it, give it away or re-use it under the terms of the Project Gutenberg License included with this eBook or online at [www.gutenberg.org](http://www.gutenberg.org). If you are not located in the United States, you will have to check the laws of the country where you are located before using this eBook.

1.E.2. If an individual Project Gutenberg™ electronic work is derived from texts not protected by U.S. copyright law (does not contain a notice indicating that it is posted with permission of the copyright holder), the work can be copied and distributed to anyone in the United States without paying any fees or charges. If you are redistributing or providing access to a work with the phrase “Project Gutenberg” associated with or appearing on the work, you must comply either with the requirements of paragraphs 1.E.1 through 1.E.7 or obtain permission for the use of the work and the Project Gutenberg™ trademark as set forth in paragraphs 1.E.8 or 1.E.9.

1.E.3. If an individual Project Gutenberg™ electronic work is posted with the permission of the copyright holder, your use and distribution must comply with both paragraphs 1.E.1 through 1.E.7 and any additional terms imposed by the copyright holder. Additional terms will be linked to the Project Gutenberg™ License for all works posted with the permission of the copyright holder found at the beginning of this work.

1.E.4. Do not unlink or detach or remove the full Project Gutenberg™ License terms from this work, or any files containing a part of this work or any other work associated with Project Gutenberg™.

1.E.5. Do not copy, display, perform, distribute or redistribute this electronic work, or any part of this electronic work, without prominently displaying the

sentence set forth in paragraph 1.E.1 with active links or immediate access to the full terms of the Project Gutenberg™ License.

1.E.6. You may convert to and distribute this work in any binary, compressed, marked up, nonproprietary or proprietary form, including any word processing or hypertext form. However, if you provide access to or distribute copies of a Project Gutenberg™ work in a format other than “Plain Vanilla ASCII” or other format used in the official version posted on the official Project Gutenberg™ website (www.gutenberg.org), you must, at no additional cost, fee or expense to the user, provide a copy, a means of exporting a copy, or a means of obtaining a copy upon request, of the work in its original “Plain Vanilla ASCII” or other form. Any alternate format must include the full Project Gutenberg™ License as specified in paragraph 1.E.1.

1.E.7. Do not charge a fee for access to, viewing, displaying, performing, copying or distributing any Project Gutenberg™ works unless you comply with paragraph 1.E.8 or 1.E.9.

1.E.8. You may charge a reasonable fee for copies of or providing access to or distributing Project Gutenberg™ electronic works provided that:

- You pay a royalty fee of 20% of the gross profits you derive from the use of Project Gutenberg™ works calculated using the method you already use to calculate your applicable taxes. The fee is owed to the owner of the Project Gutenberg™ trademark, but he has agreed to donate royalties under this paragraph to the Project Gutenberg Literary Archive Foundation. Royalty payments must be paid within 60 days following each date on which you prepare (or are legally required to prepare) your periodic tax returns. Royalty payments should be clearly marked as such and sent to the Project Gutenberg Literary Archive Foundation at the address specified in Section 4, “Information about donations to the Project Gutenberg Literary Archive Foundation.”
- You provide a full refund of any money paid by a user who notifies you in writing (or by e-mail) within 30 days of receipt that s/he does not agree to the terms of the full Project Gutenberg™ License. You must require such a user to return or destroy all copies of the works possessed in a physical medium and discontinue all use of and all access to other copies of Project Gutenberg™ works.
- You provide, in accordance with paragraph 1.F.3, a full refund of any money paid for a work or a replacement copy, if a defect in the electronic work is discovered and reported to you within 90 days of receipt of the work.
- You comply with all other terms of this agreement for free distribution of Project Gutenberg™ works.

1.E.9. If you wish to charge a fee or distribute a Project Gutenberg™ electronic work or group of works on different terms than are set forth in this agreement, you must obtain permission in writing from the Project Gutenberg Literary Archive Foundation, the manager of the Project Gutenberg™ trademark. Contact the Foundation as set forth in Section 3 below.

1.F.

1.F.1. Project Gutenberg volunteers and employees expend considerable effort to identify, do copyright research on, transcribe and proofread works not protected by U.S. copyright law in creating the Project Gutenberg™ collection. Despite these efforts, Project Gutenberg™ electronic works, and the medium on which they may be stored, may contain “Defects,” such as, but not limited to, incomplete, inaccurate or corrupt data, transcription errors, a copyright or other intellectual property infringement, a defective or damaged disk or other medium, a computer virus, or computer codes that damage or cannot be read by your equipment.

1.F.2. LIMITED WARRANTY, DISCLAIMER OF DAMAGES - Except for the “Right of Replacement or Refund” described in paragraph 1.F.3, the Project Gutenberg Literary Archive Foundation, the owner of the Project Gutenberg™ trademark, and any other party distributing a Project Gutenberg™ electronic work under this agreement, disclaim all liability to you for damages, costs and expenses, including legal fees. YOU AGREE THAT YOU HAVE NO REMEDIES FOR NEGLIGENCE, STRICT LIABILITY, BREACH OF WARRANTY OR BREACH OF CONTRACT EXCEPT THOSE PROVIDED IN PARAGRAPH 1.F.3. YOU AGREE THAT THE FOUNDATION, THE TRADEMARK OWNER, AND ANY DISTRIBUTOR UNDER THIS AGREEMENT WILL NOT BE LIABLE TO YOU FOR ACTUAL, DIRECT, INDIRECT, CONSEQUENTIAL, PUNITIVE OR INCIDENTAL DAMAGES EVEN IF YOU GIVE NOTICE OF THE POSSIBILITY OF SUCH DAMAGE.

1.F.3. LIMITED RIGHT OF REPLACEMENT OR REFUND - If you discover a defect in this electronic work within 90 days of receiving it, you can receive a refund of the money (if any) you paid for it by sending a written explanation to the person you received the work from. If you received the work on a physical medium, you must return the medium with your written explanation. The person or entity that provided you with the defective work may elect to provide a replacement copy in lieu of a refund. If you received the work electronically, the person or entity providing it to you may choose to give you a second opportunity to receive the work electronically in lieu of a refund. If the second copy is also defective, you may demand a refund in writing without further opportunities to fix the problem.

1.F.4. Except for the limited right of replacement or refund set forth in paragraph 1.F.3, this work is provided to you 'AS-IS', WITH NO OTHER WARRANTIES OF ANY KIND, EXPRESS OR IMPLIED, INCLUDING BUT NOT LIMITED TO WARRANTIES OF MERCHANTABILITY OR FITNESS FOR ANY PURPOSE.

1.F.5. Some states do not allow disclaimers of certain implied warranties or the exclusion or limitation of certain types of damages. If any disclaimer or limitation set forth in this agreement violates the law of the state applicable to this agreement, the agreement shall be interpreted to make the maximum disclaimer or limitation permitted by the applicable state law. The invalidity or unenforceability of any provision of this agreement shall not void the remaining provisions.

1.F.6. INDEMNITY - You agree to indemnify and hold the Foundation, the trademark owner, any agent or employee of the Foundation, anyone providing copies of Project Gutenberg™ electronic works in accordance with this agreement, and any volunteers associated with the production, promotion and distribution of Project Gutenberg™ electronic works, harmless from all liability, costs and expenses, including legal fees, that arise directly or indirectly from any of the following which you do or cause to occur: (a) distribution of this or any Project Gutenberg™ work, (b) alteration, modification, or additions or deletions to any Project Gutenberg™ work, and (c) any Defect you cause.

## **Section 2. Information about the Mission of Project Gutenberg™**

Project Gutenberg™ is synonymous with the free distribution of electronic works in formats readable by the widest variety of computers including obsolete, old, middle-aged and new computers. It exists because of the efforts of hundreds of volunteers and donations from people in all walks of life.

Volunteers and financial support to provide volunteers with the assistance they need are critical to reaching Project Gutenberg™'s goals and ensuring that the Project Gutenberg™ collection will remain freely available for generations to come. In 2001, the Project Gutenberg Literary Archive Foundation was created to provide a secure and permanent future for Project Gutenberg™ and future generations. To learn more about the Project Gutenberg Literary Archive Foundation and how your efforts and donations can help, see Sections 3 and 4 and the Foundation information page at [www.gutenberg.org](http://www.gutenberg.org).

## **Section 3. Information about the Project Gutenberg Literary Archive Foundation**

The Project Gutenberg Literary Archive Foundation is a non-profit 501(c)(3) educational corporation organized under the laws of the state of Mississippi and granted tax exempt status by the Internal Revenue Service. The Foundation's EIN or federal tax identification number is 64-6221541. Contributions to the Project Gutenberg Literary Archive Foundation are tax deductible to the full extent permitted by U.S. federal laws and your state's laws.

The Foundation's business office is located at 809 North 1500 West, Salt Lake City, UT 84116, (801) 596-1887. Email contact links and up to date contact information can be found at the Foundation's website and official page at [www.gutenberg.org/contact](http://www.gutenberg.org/contact)

## **Section 4. Information about Donations to the Project Gutenberg Literary Archive Foundation**

Project Gutenberg™ depends upon and cannot survive without widespread public support and donations to carry out its mission of increasing the number of public domain and licensed works that can be freely distributed in machine-readable form accessible by the widest array of equipment including outdated equipment. Many small donations (\$1 to \$5,000) are particularly important to maintaining

tax exempt status with the IRS.

The Foundation is committed to complying with the laws regulating charities and charitable donations in all 50 states of the United States. Compliance requirements are not uniform and it takes a considerable effort, much paperwork and many fees to meet and keep up with these requirements. We do not solicit donations in locations where we have not received written confirmation of compliance. To SEND DONATIONS or determine the status of compliance for any particular state visit [www.gutenberg.org/donate](http://www.gutenberg.org/donate).

While we cannot and do not solicit contributions from states where we have not met the solicitation requirements, we know of no prohibition against accepting unsolicited donations from donors in such states who approach us with offers to donate.

International donations are gratefully accepted, but we cannot make any statements concerning tax treatment of donations received from outside the United States. U.S. laws alone swamp our small staff.

Please check the Project Gutenberg web pages for current donation methods and addresses. Donations are accepted in a number of other ways including checks, online payments and credit card donations. To donate, please visit: [www.gutenberg.org/donate](http://www.gutenberg.org/donate)

## **Section 5. General Information About Project Gutenberg™ electronic works**

Professor Michael S. Hart was the originator of the Project Gutenberg™ concept of a library of electronic works that could be freely shared with anyone. For forty years, he produced and distributed Project Gutenberg™ eBooks with only a loose network of volunteer support.

Project Gutenberg™ eBooks are often created from several printed editions, all of which are confirmed as not protected by copyright in the U.S. unless a copyright notice is included. Thus, we do not necessarily keep eBooks in compliance with any particular paper edition.

Most people start at our website which has the main PG search facility: [www.gutenberg.org](http://www.gutenberg.org).

This website includes information about Project Gutenberg™, including how to make donations to the Project Gutenberg Literary Archive Foundation, how to help produce our new eBooks, and how to subscribe to our email newsletter to hear about new eBooks.