

The Project Gutenberg eBook of South Africa and the Transvaal War, Vol. 2 (of 8)

This ebook is for the use of anyone anywhere in the United States and most other parts of the world at no cost and with almost no restrictions whatsoever. You may copy it, give it away or re-use it under the terms of the Project Gutenberg License included with this ebook or online at www.gutenberg.org. If you are not located in the United States, you'll have to check the laws of the country where you are located before using this eBook.

Title: South Africa and the Transvaal War, Vol. 2 (of 8)

Author: Louis Creswicke

Release date: August 6, 2008 [eBook #26198]
Most recently updated: January 3, 2021

Language: English

Credits: Produced by Jonathan Ingram, Brownfox and the Online
Distributed Proofreading Team at <https://www.pgdp.net>

*** START OF THE PROJECT GUTENBERG EBOOK SOUTH AFRICA AND THE TRANSVAAL
WAR, VOL. 2 (OF 8) ***

TRANSCRIBERS' NOTE

For speed of loading, many illustrations have been provided as thumbnails, linked to larger versions of the images



[Pg i]

"ALL THAT WAS LEFT OF THEM."

THE BLACK WATCH AFTER THE BATTLE OF MAGERSFONTEIN.

From the Drawing by R. Caton Woodville.

SOUTH AFRICA AND THE TRANSVAAL WAR

[Pg iii]

BY

LOUIS CRESWICKE

AUTHOR OF "ROXANE," ETC.

WITH NUMEROUS ILLUSTRATIONS AND MAPS

IN SIX VOLUMES

VOL. II.—FROM THE COMMENCEMENT OF THE WAR TO THE BATTLE OF COLENZO, 15TH
DEC. 1899

EDINBURGH: T. C. & E. C. JACK

1900

[Pg v]

CONTENTS—Vol. II.

CHRONOLOGICAL TABLE	PAGE
	vii
CHAPTER I	
	PAGE
THE CRISIS AT HOME	1
IN SOUTH AFRICA	2
THE OCCUPATION OF DUNDEE	7
THE BATTLE OF GLENCOE	14
ELANDSLAAGTE	20
THE RETREAT FROM DUNDEE	32
SIR W. PENN SYMONS—GLENCOE	35
THE BATTLE OF REITFONTEIN	36
LADYSMITH	38
THE BATTLE OF LOMBARD'S KOP	41
THE DISASTER OF NICHOLSON'S NEK	45
THE SIEGE OF LADYSMITH	51
CHAPTER II	
	PAGE
THE SIEGE OF MAFEKING	55
KIMBERLEY	64
CHAPTER III	
	PAGE
NATAL	70
THE INVASION OF CAPE COLONY	76
THE BATTLE OF BELMONT	86
THE BATTLE OF GRASPAN	92
THE BATTLE OF MODDER RIVER	97
AFTER THE FIGHT	108
CHAPTER IV	
	PAGE
THE INVESTMENT OF LADYSMITH	110
ESTCOURT	119
ARMOURED TRAIN DISASTER AT CHIEVELEY	121
ESTCOURT	126

THE FIGHT ON BEACON HILL	132
LADYSMITH	135
ESTCOURT AND FRERE	139
SURPRISES AT LADYSMITH	145
FRERE CAMP	151

CHAPTER V

	PAGE
ACTIVITY AT THE CAPE	154
WITH GENERAL GATACRE	159
THE REVERSE AT STORMBERG	163
AT THE MODDER RIVER	168
THE BATTLE OF MAJESFONTEIN	171

CHAPTER VI

	PAGE
CHIEVELEY CAMP	187
THE BATTLE OF COLENZO	188

FACSIMILE OF MS. OF MR. RUDYARD KIPLING'S WAR POEM "THE ABSENT-MINDED BEGGAR"	203
---	---------------------

[Pg vi]

LIST OF ILLUSTRATIONS—VOL. II.

	PAGE
CHART SHOWING STAFF APPOINTMENTS MADE AT THE COMMENCEMENT OF THE WAR	At front

I. COLOURED PLATES

	PAGE
"ALL THAT WAS LEFT OF THEM."	
The Black Watch after the Battle of Majesfontein.	Frontispiece
By R. Caton Woodville	
OFFICER OF THE 9TH LANCERS	38
SERGEANT, KING'S ROYAL RIFLES	80
PRIVATE AND CORPORAL OF THE GORDON HIGHLANDERS	96
SERGEANT AND PRIVATE OF THE DUBLIN FUSILIERS	102
SIGHTING A NAVAL FIELD GUN	128
SERGEANTS OF THE ROYAL HORSE ARTILLERY WITH A 12-POUNDER	144
SERGEANT-MAJOR OF THE NEW SOUTH WALES LANCERS	154

2. FULL-PAGE PLATES

	PAGE
THE OUTBREAK OF WAR—THE DRAKENSBERG MOUNTAINS	6
THE OUTBREAK OF THE WAR—TRANSPORT LEAVING ENGLAND FOR THE CAPE	16
THE BATTLE OF ELANDSLAAGTE	26
BEFORE LADYSMITH—HORSE ARTILLERY GALLOPING TO TAKE UP A NEW POSITION	42
LADYSMITH, NATAL	54
NIGHT SORTIE FROM MAFEKING	64
THE BATTLE OF BELMONT	90
THE BATTLE OF MODDER RIVER	106
SCENE ON THE TUGELA	112
REPELLING AN ATTACK FROM THE TRENCHES AROUND LADYSMITH	138
FROM FRERE TO CHIEVELEY	150
STORMBERG PASS	160
THE MODDER RIVER	172
THE BATTLE OF COLENZO—QUEEN'S (ROYAL WEST SURREY) REGIMENT LEADING THE CENTRAL ATTACK	188
THE BATTLE OF COLENZO—THE DUBLIN FUSILIERS ATTEMPT TO FORD THE TUGELA	192
THE BATTLE OF COLENZO—THE LAST DESPERATE ATTEMPT TO SAVE THE GUNS	198

3. FULL-PAGE PORTRAITS

	PAGE
LIEUT.-GENERAL J. D. P. FRENCH	22

MAJOR-GENERAL SIR W. PENN SYMONS, K.C.B.	32
GENERAL JOUBERT	48
COLONEL ROBERT S. S. BADEN-POWELL, the Defender of Mafeking	58
RIGHT HON. SIR REDVERS HENRY BULLER, K.C.B., V.C.	74
LIEUT.-GENERAL LORD METHUEN, C.B.	86
GENERAL SIR GEORGE STEWART WHITE, V.C., G.C.B., the Defender of Ladysmith	118
MAJOR-GENERAL ANDREW G. WAUCHOPE, C.B.	176

4. MAPS AND ENGRAVINGS IN THE TEXT

	PAGE
COLOURED MAP OF SEAT OF WAR	At Front
MAP OF NORTHERN NATAL	9
POSITION OF FORCES BEFORE THE BATTLE OF GLENCOE	15
THE BATTLE OF GLENCOE	17
POSITION OF FORCES BEFORE THE BATTLE OF ELANDSLAAGTE, NOON	21
PLAN OF BATTLE OF ELANDSLAAGTE	25
MAP OF LADYSMITH AND SURROUNDING HEIGHTS	42
THE CREUSOT QUICK-FIRING FIELD GUN, OR "LONG TOM"	44
4.7-INCH NAVAL GUN ON IMPROVISED MOUNTING	52
12-POUNDER NAVAL GUN ON IMPROVISED CARRIAGE	52
15-POUNDER FIELD GUN	62
AN ARMoured TRAIN	68
THE MAXIM GUN	79
LORD METHUEN'S LINE OF ADVANCE	87
PLAN OF THE BATTLE OF BELMONT	90
PLAN OF THE BATTLE OF MODDER RIVER	101
COMPLETE MACHINE GUN DETACHMENT OF MOUNTED INFANTRY	118
THE 5-INCH HOWITZER OR SIEGE GUN	127
FACSIMILE OF PAGE OF NEWSPAPER PUBLISHED IN LADYSMITH DURING THE SIEGE	137
TELEGRAPH SECTION OF THE ROYAL ENGINEERS	144
4.7 NAVAL GUN ON CAPT. PERCY SCOTT'S IMPROVISED CARRIAGE	154
MAP ILLUSTRATING THE OPERATIONS ON THE SOUTH OF THE ORANGE RIVER	164
BATTLE OF MAJESFONTEIN	174
SKETCH PLAN OF POSITIONS AT MAJESFONTEIN	176
SKETCH PLAN OF BATTLE OF COLENZO	191
MAP SHOWING THE ATTEMPTED PASSAGE OF THE RIVER BY GENERAL BULLER ON DECEMBER 15	194

[Pg vii]

CHRONOLOGICAL TABLE—VOL. II.

OCTOBER.

- 11.—Boer Ultimatum time-limit expired. Great Britain commenced to be at war with Transvaal and Orange Free State.
- 12.—Text of Great Britain's reply to Boer Ultimatum issued. It stated that the conditions demanded were such as her Majesty's Government deemed it impossible to discuss.
Mr. Conyngham Greene recalled.
Armoured train captured by Boers near Mafeking.
Colonel Baden-Powell moved a large force outside Mafeking, and took up a strong defensive position.
- 13.—Newcastle abandoned.
- 14.—Sir R. Buller and Staff left England.
- 15.—Boers occupied Newcastle.
- 16.—Dundee evacuated.
- 17.—Parliament opened.
Successful sortie by Colonel Baden-Powell from Mafeking.

Armoured train in action near Kimberley during reconnaissance.

- 18.—Mr. Balfour announced that the Militia and Militia Reserves were to be called out.
- 19.—Transvaal flag hoisted at Vryburg.
- 20.—Boers repulsed by British at Talana Hill (Glencoe).
- 21.—General French, with about 2000 men, attacked a Boer force under General Kock at Elandsplaagte.
- 22.—General Symons promoted to be Major-General.
General Yule retired from Dundee on Ladysmith.
- 23.—Death of General Symons.
Mafeking bombarded.
Transvaal National Bank seized at Durban.
- 24.—Sir George White engaged Boers at Reitfontein.
Services accepted of Sir William M'Cormac, President of the Royal College of Surgeons, to attend the wounded.
- 26.—Generals Yule and White joined forces at Ladysmith.
Bombardment of Mafeking commenced.
- 28.—Boers were closing round Ladysmith.
Proclamation issued declaring the Boer "commandeering" of certain portions of Cape Colony null.
- 30.—Engagement at Lombard's Kop.
Sir George White sent out from Ladysmith to Nicholson's Nek a Mountain Battery, with the Irish Fusiliers and the Gloucesters, to turn the enemy's right flank. Mules, with guns and reserve ammunition, stampeded into enemy's lines. After gallantly defending their position for six hours, men's ammunition was exhausted, and about 800 were captured. Naval Brigade did excellent work.
- 31.—Sir Redvers Buller landed at Cape Town.

NOVEMBER.

- 1.—Boers invaded Cape Colony.
- 2.—Free Staters' position at Besters brilliantly taken by cavalry. Boers lost heavily; our casualties slight. Boers treacherously used white flag.
Colenso evacuated by the British.
Arrangements for a supplementary Naval Brigade completed.
Orders issued for mobilising the Militia.
- 3.—Naauwpoort and Stormberg evacuated by the British garrisons.
- 5.—Death of Commander Egerton, of *Powerful*.
- 6.—Ladysmith isolated.
- 9.—Boers attacked Ladysmith, and repulsed with heavy loss.
Orders issued for mobilisation of a Fifth Division.
- 10.—Engagement of Belmont. Colonel Keith Falconer killed.
- 11.—Captain Percy Scott, of H.M.S. *Terrible*, appointed commandant of the forces defending Durban.
- 12.—Lord Methuen arrived at Orange River.
- 14.—Lieutenant-General Sir Charles Warren appointed to command the Fifth Division for service in South Africa.
- 15.—Armoured train wrecked by Boers near Frere. Mr. Winston Churchill and a number of Dublin Fusiliers and Volunteers captured.
Boers defeated at Estcourt.
- 16.—Fighting near Orange River.
- 17-22.—Transports arrived at Cape Town with 22,000 troops.

- 20.—Lord Methuen's force reached Witteputts.
- 23.—Lord Methuen attacked Boers at Belmont.
Boers routed at Willow Grange.
- 25.—Lord Methuen engaged the Boers at Graspan (Enslin), and after four hours' hard fighting carried position.
- 26.—Mooi River Column joined at Frere by General Hildyard.
- 28.—Lord Methuen engaged enemy, 8000 strong, at Modder River, and after ten hours' desperate fighting, drove them back.
- 30.—Sixth Division for South Africa notified.

DECEMBER.

- 2.—General Clery reached Frere.
- 3.—Transport *Ismore* wrecked 180 miles north of Cape Town—all troops landed.
- 6.—Sortie from Kimberley. Major Scott Turner killed.
- 7.—Arundel occupied by British.
- 8.—British sortie from Ladysmith, Lombard's Kop being carried.
- 9.—General Gatacre sustained serious reverse at Stormberg, having been misled by guides.
Lieutenant-Colonel Metcalfe, 2nd Rifle Brigade, with 500 men from Ladysmith, captured Surprise Hill, destroying a howitzer.
- 10.—General French drove the enemy from Vaal Kop.
- 11.—Lord Methuen attacked 12,000 Boers entrenched at Majesfontein, but attack failed, although British troops held their position. Major-General Wauchope, Major Lord Winchester, and Colonel Downman killed.
- 13.—General French defeated 1800 Boers between Arundel and Naauwpoort. British loss, 1 killed, 8 wounded.
- 14.—Orders given for the mobilisation of a Sixth Division, and a Seventh in reserve.
Sir Charles Warren and Staff arrived at the Cape.
- 15.—General Buller suffered a serious reverse at Colenso, troops having to retire to Chieveley, leaving behind 11 guns.
General Hector Macdonald appointed to succeed General Wauchope.

CHART OF STAFF APPOINTMENTS MADE AT THE COMMENCEMENT OF THE WAR,

AS ISSUED BY THE WAR OFFICE, 7TH OCTOBER, 1899.

LINES OF COMMUNICATION.

The Lines of Communication will be under the general command and direction of Lieut.-General Sir F. W. E. F. Forestier-Walker, K.C.B., C.M.G.

The following Officers will be employed and will have the Staff position shown opposite their names:—

Names of Officers Selected.	Staff Position.
Colonel H. H. Settle, C.B., D.S.O., p.s.c.	Colonel on Staff.
Captain F. A. Molony, p.s.c., R.E.	Staff Officer to Colonel on Staff.
Colonel J. W. Murray, p.s.c.	Colonel on Staff.
Colonel W. D. Richardson, C.B.	Deputy Adjutant-General for Supplies and Transport.
Lieut.-Colonel F. F. Johnson, Army Service Corps	Staff Officer to Deputy Adjutant-General for Supplies and Transport.
Brevet-Colonel C. H. Bridge, C.B., Army Service Corps	Deputy Adjutant-General for Transport.
Brevet-Major (local Lieut.-Colonel) E. P. C. Girouard, D.S.O., R.E.	Director of Railways. ^[A]
Captain H. G. Joly de Lotbinière, R.E.	Staff Officer to Director of Railways.
Captain (local Major) J. H. Twiss, R.E.	Assistant Directors of Railways. ^[B]

Captain (local Major) V. Murray, R.E.	Deputy-Assistant Directors of Railways.
Major J. E. Capper, R.E.	
Captain H. C. Manton, R.E.	
Capt. W. D. Waghorn, R.E.	
Major (local Lieut.-Colonel) A. E. Wrottesley, R.E.	
	Director of Telegraphs. ^[A]
Colonel R. S. R. Fetherstonhaugh, h.p.	Station Commandants. ^[A]
Brevet-Colonel C. P. Ridley, 2nd Bn. Manchester Regt.	
Brevet-Lieut.-Colonel P. T. Rivett-Carnac, 1st Bn. West Riding Regt.	Staff Officers to Station Commandants. ^[C]
Brevet-Lieut.-Colonel H. P. Shekleton, p.s.c., 1st Bn. South Lancashire Regt.	
Capt. J. G. Baldwin, Royal Garrison Artillery	
Captain A. E. Lascelles, 2nd Bn. Norfolk Regt.	
Captain C. R. Ballard, 1st Bn. Norfolk Regt.	
Captain C. V. C. Hobart, D.S.O., 2nd Bn. Grenadier Guards	Assistant Adjutant-Generals.
Brevet-Colonel E. W. D. Ward, C.B., Army Service Corps.	
Col. J. K. Trotter, C.M.G., p.s.c.	
Lieut.-Col. F. W. Bennet, R.E.	
Brevet-Lieut.-Colonel H. M. Lawson, p.s.c., R.E.	
Lieut.-Colonel S. H. Winter, Army Service Corps	Deputy-Assistant Adjutant-Generals.
Lieut.-Colonel W. R. Winter, Army Service Corps	
Lieut.-Col. R. B. M'Comb, Army Service Corps	
Brevet-Lieut.-Colonel F. W. B. Landon, Army Service Corps	
Major J. H. Poett, p.s.c., 2nd Bn. Dorsetshire Regt.	
Major C. Rawnsley, Army Service Corps	
Major R. B. Gaisford, p.s.c., Royal Scots Fusiliers	
Brevet-Major E. G. T. Bainbridge, 2nd Bn. East Kent Regt.	
Major R. C. B. Haking, p.s.c., Hampshire Regt.	
Major A. W. Thorneycroft, 2nd Bn. Royal Scots Fusiliers	
Captain E. H. Hughes, p.s.c., 1st Bn. York and Lancaster Regt.	
Captain G. S. St Aubyn, King's Royal Rifle Corps	
Brevet-Lieut.-Colonel J. Adye, p.s.c., Royal Garrison Artillery	
Major H. N. C. Heath, p.s.c., Yorkshire Light Infantry	
Brevet-Major C. J. Mackenzie, 1st Bn. Seaforth Highlanders	
Major R. L. Walter, 7th Hussars	
Major E. F. Gosset, p.s.c., 2nd Bn. East Yorkshire Regt.	
Brevet-Major A. G. Hunter-Weston, R.E.	General Duty.
Major G. D. Baker, p.s.c., Royal Garrison Artillery	
Major E. S. C. Kennedy, West India Regt.	
Captain A. W. Elles, 2nd Bn. Yorkshire Light Infantry	
Captain E. St G. Pratt, 1st Bn. Durham Light Infantry	
Capt. C. B. Jervis-Edwards, 1st Bn. Duke of Cornwall's Light Infantry	
Captain F. B. Maurice, Derbyshire Regt.	
Lieutenant W. M. C. Vandeleur, 2nd Bn. Essex Regt.	
Lieutenant G. P. Appleby, 1st Bn. Bedfordshire Regt.	
Lieutenant F. S. Reeves, 1st Bn. East	

WAR OFFICE, 4th October 1899.

Note.—The above list only shows the Officers employed on Staff duties on the Lines of Communication. It does not show those employed on medical, ordnance, clerical, supply, pay, &c., services.—C. G.

FOOTNOTES:

- [A] Graded as Assistant Adjutant-Generals.
 [B] Graded as Deputy-Assistant Adjutant-Generals.
 [C] Graded as Staff Captains.

NATAL FIELD FORCE.

Staff Position.	Names of Officers Selected.
General Officer Commanding (Lieut.- General on Staff)	Lieutenant-General Sir G. S. White, V.C., G.C.B., G.C.S.I., G.C.I.E.
Assistant Military Secretary	Colonel B. Duff, C.I.E., p.s.c., Indian Staff Corps.
Aides-de-Camp (2)	Captain R. G. Brooke, D.S.O., 7th Hussars. Captain F. Lyon, R.F.A.
Assistant Adjutant-General Deputy-Assistant Adjutant- Generals	Colonel I. S. M. Hamilton, C.B., D.S.O. (a) Major F. Hammersley, p.s.c., Lancashire Fusiliers. (b) Major E. R. O. Ludlow, p.s.c., Army Service Corps.
Officer Commanding Royal Artillery	Lieut.-Colonel and Brevet-Col. C. J. Long, R.H.A.
Commanding Royal Engineer (Colonel on Staff)	Lieut.-Colonel W. F. N. Noel, R.E.
Principal Medical Officer Medical Officer Chaplains (2)	Lieut.-Colonel R. Exham, R.A.M.C. Major J. F. Bateson, M.B., R.A.M.C. Rev. L. J. Matthews (R.C.) Rev. E. G. Macpherson, B.A.
Assistant Provost- Marshal ^[D]	Major A. G. Chichester, 1st Bn. Royal Irish Regt.
Signalling Officer	Captain J. S. Cayzer, 7th Dragoon Guards.

4TH DIVISION.

General Officer Commanding (Lieut.- General on Staff)	Colonel (local Lieut.-General) Sir W. P. Symons, K.C.B.
Aides-de-Camp (2)	
Assistant Adjutant-General Deputy-Assistant Adjutant- Generals	Colonel C. E. Beckett, C.B., p.s.c. (a) Major and Brevet-Lieut.-Colonel Sir H. S. Rawlinson, Bart., p.s.c., 2nd Bn. Coldstream Guards. (b) Captain T. D. Foster, Army Service Corps.

7TH BRIGADE.

Major-General	Colonel (local Major-General) F. Howard, C.B., C.M.G., A.D.C.
Aide-de-Camp	Captain H. E. Vernon, D.S.O., 4th Bn. Rifle Brigade.
Brigade-Major	Brevet-Lieut.-Colonel Hon. C. G. Fortescue, C.M.G., p.s.c., Rifle Brigade.

8TH BRIGADE.

Major-General Aide-de-Camp Brigade-Major	To be nominated locally.
--	--------------------------

3RD CAVALRY BRIGADE.

Major-General	Colonel (local Major-General) J. F. Brocklehurst, M.V.O.
Aide-de-Camp	Lieutenant H. W. Viscount Crichton, Royal Horse Guards.
Brigade-Major	Captain G. P. Wyndham, p.s.c., 16th Lancers.

FOOTNOTES:

[D] Graded as a Deputy-Assistant Adjutant-General.

STAFF OF 1ST ARMY CORPS.

Staff Position.	Names of Officers Selected.
General Officer Commanding Army Corps (General Commanding-in-Chief)	General Rt. Hon. Sir R. H. Buller, V.C., G.C.B., K.C.M.G.
Military Secretary	Colonel Hon. F. W. Stopford, C.B., p.s.c.
Aides-de-Camp (4)	Captain H. N. Schofield, R.A. Captain C. J. Sackville-West, King's Royal Rifle Corps. Lieutenant A. R. Trotter, 2nd Life Guards. 2nd Lieut. C. A. Howard, Shropshire Light Infantry.
Chief of the General Staff (Major-General on Staff)	Major-General Sir A. Hunter, K.C.B., D.S.O.
Aide-de-Camp	Brevet-Major A. J. Kings, Royal Lancaster Regt.
Deputy Adjutant-General	Colonel A. S. Wynne, C.B.
Assistant Adjutant-Generals (2)	Colonel H. S. G. Miles, M.V.O., p.s.c. Colonel C. W. H. Douglas, A.D.C.
Deputy-Assistant Adjutant-Generals (4)	(a) Lieut.-Colonel C. à Court, p.s.c. (a) Major L. E. Kiggell, p.s.c., Royal Warwickshire Regt. (b) Major P. J. Lewis, Army Service Corps. (b) Major A. H. Thomas, Army Service Corps.
Commandant, Head-Quarters ^[E]	Colonel R. Pole-Carew, C.B., h.p.
Principal Medical Officer	Surgeon-General W. D. Wilson, M.B.
Medical Officers	Major W. G. A. Bedford, M.B., R.A.M.C. Captain M. L. Hughes, R.A.M.C.
Provost Marshal ^[E]	Major Hon. J. H. G. Byng, p.s.c., 10th Hussars.
Intelligence Duties—	
Assistant Adjutant-General (1)	Major E. A. Altham, p.s.c., Royal Scots.
Deputy-Assistant Adjutant-Generals (2)	Major H. J. Evans, p.s.c., Liverpool Regiment. Captain Hon. F. Gordon, p.s.c., Gor. Highlanders.
Deputy-Assistant Adjutant-General for Topography	Lieut.-Colonel W. W. C. Verner, p.s.c.
Commanding Royal Artillery (Major-General on Staff)	Colonel (local Major-Gen.) G. H. Marshall.
Staff Officer, Royal Artillery	Major H. C. Sclater, R.A.
Aide-de-Camp, R.A.	Captain A. D. Kirby, R.F.A.
Chief Engineer (Major-General on Staff)	Colonel (local Major-Gen.) E. Wood, C.B.
Staff Officer, Royal Engineers	Major E. H. Bethell, p.s.c., Royal Engineers.
Aide-de-Camp, Royal Engineers	Brevet-Major R. S. Curtis, Royal Engineers.
Military Mounted Police ^[F]	Brevet-Major R. M. Poore, 7th Hussars.
Press Censor ^[F]	Major W. D. Jones, p.s.c., Wiltshire Regt.
Principal Chaplain	Rev. E. H. Goodwin, B.A.
Director of Signalling ^[E]	Major (local Lieut.-Colonel) E. Rhodes, D.S.O., Royal Berks Regt.
Chief Ordnance Officer	Colonel R. F. N. Clarke, Army Ord. Department.
Principal Veterinary Officer	Veterinary Lieut.-Colonel I. Matthews, Army Veterinary Department.
Orderly Veterinary Officer	
CORPS TROOPS.	
Officer Commanding Corps Artillery (Colonel on Staff)	Colonel C. M. H. Downing.
Adjutant	Captain E. S. E. W. Russell, Royal Field Artillery.

Officer Commanding Royal Horse
Artillery
Adjutant, R.H.A.

Officer Commanding F.A. (I.)
Adjutant
Officer Commanding Field Artillery (II.)
Adjutant
Officer Commanding Corps Troops,
Royal Engineers
Adjutant

Lieut.-Colonel W. L. Davidson, Royal
Horse Artillery.
Captain G. W. Biddulph, Royal Horse
Artillery.
Lieut.-Colonel J. S. S. Barker, p.s.c.,
R.F.A.
Captain E. J. Duffus, R.F.A.
Lieut.-Colonel P. C. E. Newbigging,
R.F.A.
Captain E. C. Cameron, Royal Field
Artillery.
Lieut.-Colonel C. A. Rochfort-Boyd,
R.E.
Lieut. S. D. Barrow, R.E.

FOOTNOTES:

- [E] Graded as Assistant Adjutant-General.
[F] Graded as Deputy-Assistant Adjutant-Generals.

1ST ARMY CORPS—1ST DIVISION.

Staff Position.	Names of Officers Selected.
General Officer Commanding (Lieut.-General on Staff) Aides-de-Camp (2)	Lieut.-General P. S. Lord Methuen, K.C.V.O., C.B., C.M.G. Major H. Streatfield, Grenadier Guards. Captain J. A. Bell-Smyth, 1st Dragoon Guards.
Assistant Adjutant-General Deputy-Assistant Adjutant- Generals	Colonel R. B. Mainwaring, C.M.G. (a) Brevet Lieut.-Colonel H. P. Northcott, C.B., p.s.c., Leinster Regt. (b) Major R. H. L. Warner, p.s.c., Army Service Corps.
Assistant-Provost-Marshal ^[G] Chaplains (2)	Captain R. J. Ross, 1st Bn. Middlesex Regt. Rev. T. F. Falkner, M.A. Rev. E. M. Morgan (R.C.)
Principal Medical Officer Medical Officer	Colonel E. Townsend, C.B., M.D., R.A.M.C. Major C. H. Burtchaell, M.B., R.A.M.C.
Divisional Signalling Officer	Lieut. Hon. E. D. Loch, D.S.O., 1st Bn. Grenadier Guards.
1ST BRIGADE.	
Major-General	Major-General Sir H. E. Colvile, K.C.M.G., C.B.
Aide-de-Camp	Captain G. C. Nugent, Grenadier Guards.
Brigade-Major	Captain H. G. Ruggles-Brise, p.s.c., Grenadier Guards.
2ND BRIGADE.	
Major-General	Major-General H. J. T. Hildyard, C.B., p.s.c.
Aide-de-Camp	Lieut. A. Blair, King's Own Scottish Borderers.
Brigade-Major	Major L. Munro, p.s.c., Hampshire Regt.

FOOTNOTES:

- [G] Graded as Deputy-Assistant Adjutant-General.

1ST ARMY CORPS—2ND DIVISION.

Staff Position.	Names of Officers Selected.
General Officer Commanding (Lieut.-General on Staff) Aides-de-Camp (2)	Major-General (Local Lieut.-General) Sir C. F. Clery, K.C.B., p.s.c. Major F. E. Cooper, Royal Artillery, p.s.c. Captain L. Parke, Durham Light Infantry.
Assistant Adjutant-General Deputy-Assistant Adjutant- General	Major and Bt.-Colonel B. M. Hamilton, p.s.c., East Yorkshire Regiment. (a) Captain H. E. Gogarty, p.s.c., Royal Scots Fusiliers. (b) Captain W. G. B. Boyce, Army Service Corps.
Assistant Provost-Marshal ^[H] Chaplains (2)	Major G. F. Ellison, p.s.c., Royal Warwickshire Regt. Rev. A. A. L. Gedge, B.A. Rev. J. Robertson (P.).

Principal Medical Officer
Medical Officer
Divisional Signalling Officer

Colonel T. J. Gallwey, M.D., C.B., R.A.M.C.
Major W. Babbie, M.B., C.M.B., R.A.M.C.
Lieut. J. S. Cavendish, 1st Life Guards.

Major-General
Aide-de-Camp
Brigade-Major

3RD BRIGADE.
Maj.-Gen. A. G. Wauchope, C.B., C.M.G.
Captain J. G. Rennie, R.H.
Major and Bt.-Lieut.-Col. J. S. Ewart, p.s.c.,
Cameron Highlanders.

Major-General
Aide-de-Camp
Brigade-Major

4TH BRIGADE.
Major-General Hon. N. G. Lyttelton, C.B.
Captain Hon. H. Yarde-Buller, Rifle
Brigade.
Captain H. H. Wilson, p.s.c., Rifle Brigade.

FOOTNOTES:

[H] Graded as a Deputy-Assistant Adjutant-General.

1ST ARMY CORPS—3RD DIVISION.

Staff Position.	Names of Officers Selected.
General Officer Commanding (Lieut.-General on Staff)	Major-General (local Lieut.-Gen.) Sir W. F. Gatacre, K.C.B., D.S.O., p.s.c.
Aides-de-Camp (2)	Lieutenant A. J. M'Neill, 1st Bn. Seaforth Highlanders.
Assistant Adjutant-General Deputy-Assistant Adjutant-Generals	Colonel R. E. Allen, p.s.c. (a) Lieut.-Colonel W. H. H. Waters, M.V.O., p.s.c. (b) Major P. E. F. Hobbs, Army Service Corps.
Assistant Provost-Marshal ^[I] Chaplains (2)	Captain J. R. F. Sladen, p.s.c., East Yorkshire Regt. Rev. E. Ryan (R.C.) Rev. R. Armitage, M.A.
Principal Medical Officer Medical Officer Divisional Signalling Officer	Lieut.-Colonel J. D. Edge, M.D., R.A.M.C. Maj. G. E. Twiss, R.A.M.C. Captain S. Fitz G. Cox, 2nd Bn. Lincolnshire Regt.
Major-General Aide-de-Camp Brigade-Major	5TH BRIGADE. Major-General A. Fitzroy Hart, C.B., p.s.c. Captain Hon. St L. H. Jervis, King's Royal Rifle Corps. Major C. R. R. MacGrigor, p.s.c., King's Royal Rifle Corps.
Major-General Aide-de-Camp Brigade-Major	6TH BRIGADE. Major-General G. Barton, C.B., p.s.c. Captain J. A. E. MacBean, D.S.O., p.s.c., Royal Dublin Fusiliers.

FOOTNOTES:

[I] Graded as a Deputy-Assistant Adjutant-General.

STAFF OF CAVALRY DIVISION.

Staff Position.	Names of Officers Selected.
General Officer Commanding (Lieut.-General on Staff)	Col. (Lieut.-General) J. D. P. French.
Aides-de-Camp (2)	Lieutenant J. P. Milbanke, 10th Hussars.
Assistant Adjutant-General Deputy-Assistant Adjutant-Generals	Colonel Hon. G. H. Gough, C.B., p.s.c. (a) Major D. Haig, p.s.c., 7th Hussars. (b) Major G. O. Welch, Army Service Corps.
Officer Commanding, Royal Horse Artillery Adjutant, R.H.A. Chaplain (1) ^[K]	Lieut.-Colonel F. J. W. Eustace, R.H.A. Capt. A. D'A. King, R.H.A. Rev. W. C. Haines
Principal Medical Officer Medical Officer	Lieut.-Colonel W. Donovan, Royal Army Medical Corps. Major H. G. Hathaway, Royal Army Med. Corps.

Assistant Provost-Marshal^[L]
Intelligence Department—
Deputy-Assistant Adjutant-
General

Major-General
Aide-de-Camp
Brigade-Major
Officer Commanding Mounted
Infantry^[J]
Adjutant Mounted Infantry^[L]

Major-General
Aide-de-Camp
Brigade-Major
Officer Commanding Mounted
Infantry^[J]
Adjutant Mounted Infantry^[L]

Captain P. A. Kenna, V.C., 21st Lancers.

Captain Hon. H. A. Lawrence, p.s.c., 17th
Lancers.

1ST BRIGADE.
Col. (local Major-General) J. M. Babington.
Lieutenant F. W. Wormald, 7th Hussars.
Captain C. J. Briggs, 1st Dragoon Guards.
Major and Brevet-Lieut.-Colonel E. A. H.
Alderson, p.s.c., Royal West Kent Regt.
Captain H. M'Micking, Royal Scots.

2ND BRIGADE.
Colonel (local Major-Gen.) J. P. Brabazon,
C.B., A.D.C.
Major Hon. C. E. Bingham, 1st Life Guards.
Captain Hon. T. W. Brand, 10th Hussars.
Captain and Brevet-Lieut.-Colonel R. J.
Tudway, 2nd Bn. Essex Regt.
Captain H. L. Ruck-Keene, Oxford. Light
Infantry.

COLERIDGE GROVE, M.S.

2nd October 1899.

FOOTNOTES:

- [J] Graded as Assistant Adjutant-General.
- [K] Will act for both Brigades.
- [L] Graded as Deputy-Assistant Adjutant-Generals.

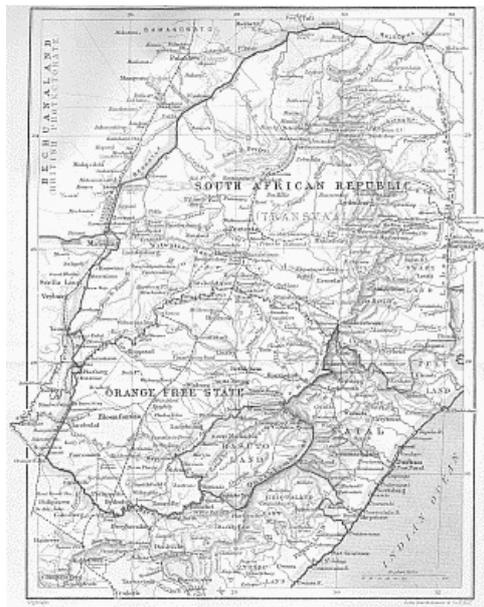

MAP OF THE SEAT OF WAR

**Illustrating "South Africa and the
Transvaal War," by Louis
Creswicke.**

SOUTH AFRICA AND THE TRANSVAAL WAR

CHAPTER I

THE CRISIS AT HOME

"Patience, long sick to death, is dead. Too long
Have sloth and doubt and treason bidden us be

What Cromwell's England was not, when the sea
 To him bore witness, given of Blake, how strong
 She stood, a commonweal that brooked no wrong
 From foes less vile than men like wolves set free,
 Whose war is waged where none may fight or flee—
 With women and with weanlings. Speech and song
 Lack utterance now for loathing. Scarce we hear
 Foul tongues, that blacken God's dishonoured name
 With prayers turned curses and with praise found
 shame,
 Defy the truth whose witness now draws near
 To scourge these dogs, agape with jaws afoam,
 Down out of life. Strike, England, and strike home."

—ALGERNON CHARLES SWINBURNE.

In the face of the insolent Ultimatum which had been addressed to Great Britain by the South African Republic, the nation closed its ranks and relegated party controversy to a more appropriate season. The British people were temporarily in accord. A wave of indignation surged over the country, and united men of different shades of politics and of varying religious creeds, making them forget their private feuds, and remember only the paramount fact that they were sons of the Empire. There were some, it is true, who remained afar off—a few exceptions to prove the rule of unanimity, beings with souls so dead that never to themselves had said, "This is my own, my native land," and who yet looked upon the Boer as an object of commiseration. But these were, first, men linked either by birth or family ties with the Afrikaner cause; second, fractious Irishmen and political obstructionists who posed for notoriety at any price; and, third, eccentrics and originals, whose sense of opposition forbade them from floating at any time with the tide of public opinion. Every one else cried aloud for a chance to uphold Great Britain's prestige, and the War Office was so beset with applications from volunteers for the front that it was found almost impossible even to consider them. Nor was the excitement confined to officers alone. Recruiting went on apace, and not only did recruits pour in, but deserters, who had slunk away from regimental duty, now returned and gave themselves up, praying to be allowed to suffer any penalty and then march out to battle as soldiers of the Queen! Two Royal Proclamations having been issued—the one directing the continuance in army service, until discharged or transferred to the reserve, of soldiers whose term of service had expired or was about to expire; the other, ordering the army reserve to be called out on permanent service—some 25,000 men received notice to rejoin the colours. These in large numbers promptly appeared. The New South Wales Lancers, who had been going through a course of cavalry training at Aldershot, at once volunteered their services and started for the Cape amidst scenes of great enthusiasm. Other colonial troops were as eager to join, and the spirit of military rivalry throughout Her Majesty's dominions was both amazing and inspiring.

[Pg 2]

Queensland had the honour of opening the ball. Her sympathy with the policy of Great Britain and her loyalty to the mother country was shown in practical form. She intimated, in the event of hostilities, her willingness to send 250 mounted infantry and a machine-gun to the front. New Zealand followed suit; she also offered two companies of mounted rifles fully equipped at the cost of the Colony. These offers were gratefully accepted. Not to be behind-hand, Western Australia and Tasmania made similar offers, and Her Majesty's Government gladly agreed to accept one unit of 125 men from each. The Parliament of Victoria voted the despatch of a contingent of 250 men to South Africa, and the Governments of New South Wales and South Australia actively discussed similar measures. This expression of Colonial public opinion, embodying as it did the independent judgments of so many free juries, uninfluenced by personal or direct interests, had a significance which, besides being politically important, was eminently satisfactory. All Her Majesty's dominions, on which the sun never sets, were at this critical moment holding hands in a wide circle that encompassed the earth, and the picture of the small mother country with all her big children gathered around her in her hour of need was not one that the romance of history can afford to disregard.

IN SOUTH AFRICA

Before hostilities had actually begun, refugees from Johannesburg began to pour down to Natal and the Cape, and there were daily reports of insults received by the Uitlanders at the hands of the Boers. Ladies were spat upon, and passengers suffered indignities sufficient to make an Englishman's blood boil. Fresh troops began to arrive from India, and Sir George White, in a chorus of farewell shouts, "Remember Majuba," went off from Durban to Pietermaritzburg. This was on the 7th of October 1899. At that time the troops were thus distributed:—

[Pg 3]

At Pietermaritzburg—1st Battalion Manchester Regiment and Mounted Infantry Company; 2nd Battalion King's Royal Rifle Corps.

At Estcourt—Detachment Natal Naval Volunteers; Natal Royal Rifles.

At Colenso—Durban Light Infantry.

At Ladysmith—5th Lancers; Detachment 19th Hussars; Brigade Division, Royal Artillery; 10th

Mountain Battery, Royal Garrison Artillery; 23rd Company, Royal Engineers; 1st Battalion Devonshire Regiment; 1st Battalion Liverpool Regiment, and Mounted Infantry Company; 26th (two sections) British Field Hospital, and Colonial troops.

At Glencoe—18th Hussars; Brigade Division, Royal Artillery; 1st Battalion Leicestershire Regiment, and Mounted Infantry Company; 1st Battalion King's Royal Rifle Corps, and Mounted Infantry Company; 2nd Battalion Royal Dublin Fusiliers, and Mounted Infantry Company; 6th Veterinary Field Hospital.

There was also one Company 1st Battalion King's Royal Rifle Corps at Eshowe, and a detachment of the Umvoti Mounted Rifles at Helpmakaar.

Meanwhile, at Pretoria, the Boers, protesting at the notice taken of the "chimerical grievances of the so-called Uitlanders," made energetic efforts to appoint General Viljeon, a rabid anti-Briton, in place of General Joubert as Commander-in-Chief of the Transvaal forces.

The troops under Commandant Cronje, the hero of Potchefstroom, advanced nearer to the border, in the direction of Mafeking, and in the expectation of attack, this town was securely fortified, while all the women and children were advised to leave. The fortification of Kimberley was also commenced. The European exodus from all quarters continued, defenceless men and women alike being subjected to insult and ill-treatment by the Boers. Mr. Kruger's birthday was kept at Pretoria with general rejoicing, and on the following day a telegram was sent by President Kruger to the *New York World* saying:—

"Through the *World* I thank the people of the United States most sincerely for their sympathy. Last Monday the Republic gave Great Britain forty-eight hours' notice within which to give the Republic an assurance that the present dispute would be settled by arbitration or other peaceful means, and that the troops would be removed from the borders. This expires at five to-day. The British Agent has been recalled. War is certain. The Republics are determined, if they must belong to Great Britain, that a price will have to be paid which will stagger humanity. They have, however, full faith. The sun of liberty will arise in South Africa as it arose in North America."

[Pg 4]

From this letter it was patent that Mr. Kruger was either pursuing his policy of bluff, or had made long and elaborate preparations for war with the British. On the same date an announcement was published in the town of Pretoria:—

"GOVERNMENT HOUSE, *October 11.*

"Her Majesty's Agent at Pretoria was to-day instructed to make the following communication to the Government of the South African Republic: 'The Imperial Government have received with great regret the peremptory demands of the Government of the South African Republic conveyed in the telegram of October 9. You will inform the Government of the South African Republic that the conditions demanded by the Government of the South African Republic are such as Her Majesty's Government deem it impossible to discuss. With the delivery of the above,' the Imperial Government add, 'as the Transvaal Government stated in their Note that a refusal to comply with their demands would be regarded as a formal declaration of war, the British Agent is instructed to ask for his passports.'"

Of course, this news caused intense excitement, and all who had remained sanguine of peace now gave up hope. At Bloemfontein President Steyn simultaneously issued a Proclamation to the Burghers of the Free State. He said that "the sister Republic is about to be attacked by an unscrupulous enemy, who has long looked for a pretext to annihilate the Afrikaners."

He went on to say that the people of the Orange Free State were bound to the Transvaal by many ties, as well as by formal treaty, and solemnly declared, in the presence of the Almighty, that they are compelled to resist a powerful enemy owing to the injustice done to their kith and kin.

Solemn obligations, continued the Proclamation, have not protected the Transvaal against an annexation conspiracy. When its independence ceases, the existence of the Orange Free State as an independent State will be meaningless. Experience in the past has shown that no reliance can be placed on the solemn promises and obligations of Great Britain when the Administration at the helm is prepared to tread treaties under foot.

After giving a historical sketch of the wrongs which he alleged had been done to the Transvaal, President Steyn said: "The original Conventions have been twisted and turned by Great Britain into a means of exercising tyranny against the Transvaal, which has not returned the injustice done to it in the past. No gratitude has been shown for the indulgence which was granted to British subjects, who, according to law, had forfeited their lives and property. Compliance with the British demands would be equivalent to the loss of our independence, which has been gained by our blood and tears. For many years British troops have been concentrating on the borders of the Transvaal in order to compel it by terrorism to comply with British claims. The crafty plans of those with whom love of gold is the motive are now being realised. While acknowledging the honour of thousands of Englishmen who abhor deeds of robbery and violence, the Orange Free State execrates the wrongful deeds of a British statesman."

[Pg 5]

After expressing confidence that the Almighty would help and aid them, and counselling the Burghers to do nothing unworthy of Christians and Burghers of the Free State, the President concluded with the following words: "Burghers of the Free State, stand up as one man against the oppressor and violator of right."

Meanwhile Sir George White, accompanied by Colonel Ian Hamilton (Assistant Adjutant-General), Colonel Duff (Assistant Military Secretary), Lieutenant-Colonel Sir Henry Rawlinson, and Captains Brooke and Lyon, aides-de-camp, was proceeding on his journey to Ladysmith. The principal British camps were situated near Glencoe Junction and Ladysmith, and around these

some twelve or fifteen thousand Boers were reported to be stationed between Sandspruit, Volksrust, and Wakkerstroom, while on the western side the Natal border was threatened by the Orange Free State's forces, which were posted in the neighbourhood of Van Reenen's Pass.

A Proclamation, signed by Sir Alfred Milner and Mr. Schreiner, was issued in Cape Town, warning British subjects of their duty to the Queen, while at the same time the German Consul-General officially ordered his countrymen to remain neutral. A similar warning was given by the German Consul to Germans in Johannesburg. Preparations were made for the immediate landing of a Naval Brigade from the British battleships in Simon's Bay, and volunteers of all kinds hurried to tender their services for special corps. In Pretoria a further manifesto was issued, calling on Afrikanders to resist the British demands, and accusing Lord Salisbury, Mr. Chamberlain, and Sir Alfred Milner of pursuing a "criminal policy." It also declared that it was perfectly clear that the desire and object of Great Britain was to deprive the Transvaal Republic of its independence on account of the gold-mining industry on the Rand.

The manifesto went on to say that Great Britain had offered two alternatives—a five years' franchise or war. It pointed out that the difference between the two Governments of two years in the matter of the franchise had been considered as a sufficient justification for Her Majesty's Government to endeavour to swallow up the Republics, and it reminded the Afrikanders that God would assuredly defend the right.

The manifesto was signed "Francois Willem Reitz, Secretary of State." It created a profound sensation, and a million copies were printed in Dutch and English.

By this time General Viljoen, in command of the Free State artillery, was marching towards Albertina, and a party of Boers was encroaching on the Natal border near Berg. Newcastle was warned that a state of war had begun. It was abandoned by the British, and taken possession of by the Boers, while Mafeking held itself in readiness to withstand the enemy. At Sandspruit the Boers were scattered in various camps over a wide area, and on the Portuguese border the Barberton and Lydenburg commandoes were concentrating. Terrified refugees were still fleeing to the Cape in such large numbers that it was almost impossible to find accommodation for them, and large sums of money were being subscribed both there and in Great Britain for the relief of the unhappy exiles. Mr. Rhodes, as usual, gave munificently in aid of the sufferers, and Sir Alfred Milner exerted himself to save the unhappy victims of British and Boer disagreement from destitution. The treatment that these poor persons received from the Boers in the course of their journey caused intense indignation, and profound sympathy was felt for the homeless ones who thus suddenly had been cast adrift from domestic comfort to complete poverty.

[Pg 6]

It was now believed that, following the precedent of 1881, an attempt would be made to isolate Mafeking and Kimberley, and carry on irregular sieges at these places. The enemy's forces on the northern frontier of Natal were estimated at some 13,000 men, while at Mafeking and Kimberley they were supposed to number some three thousand each. On the east, the seaport of Lorenzo Marques now sprung into great importance, and the supposed neutralisation of the harbour was effected.

On the 11th of October Mr. Coningham Greene, the British Agent in Pretoria, left that place for Cape Town; and on the 14th General Sir Redvers Buller, as Commander-in-chief of the British forces engaged against the Boer Republics, started from England. The state of war had commenced in earnest. The Boers in hot haste began to issue further Proclamations, and President Steyn continued to call on his Burghers to "stand up as one man against the oppressor and violator of rights." Twenty-four hours later they were over the border, tearing up railway lines and severing telegraph wires, and thus cutting off communication between Mafeking, Vryburg, Rhodesia, and Cape Colony. The investment of Kimberley was imminent, but it was generally believed that the Diamond City was strong enough to hold its own till our troops should come to the rescue. The First Brigade of the Army Service Corps started on the 20th of October from Southampton, the second left on the following day, and the third sailed on Sunday the 22nd. About the same time the Canadian Government decided to contribute 1000 men for service in South Africa, and the New Zealand Contingent sailed for the Cape.

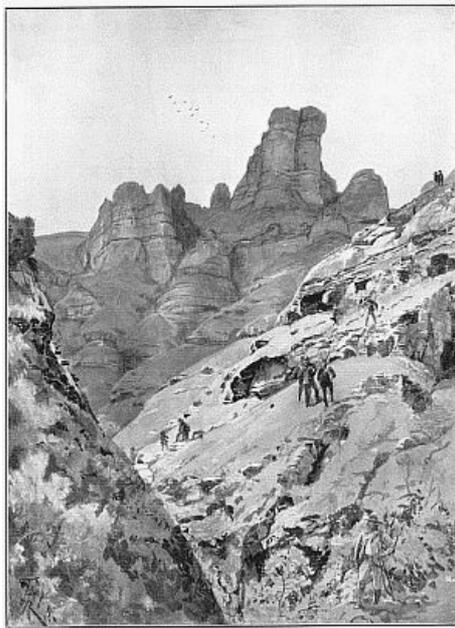

**THE OUTBREAK OF WAR—THE
DRAKENSBERG MOUNTAINS
WHERE THE BOERS WERE
LAAGERED.**

In spite of the energetic movements that were suddenly set on foot, a few pessimists ventured to declare that we would be bound to reap the results of our previous unpreparedness, and that in consequence of our procrastination and the weakness of the Government in not having taken the initiative and allowed us to mobilise earlier, the Boers would get a good six weeks' start—a loss it would be hard for the best tacticians or the finest fighting men in the world to retrieve. But the mouths of the grumblers were silenced. Every one was convinced that the fate of the nation was perfectly safe in the hands of Sir Redvers Buller and Mr. Thomas Atkins, and, so convinced, thousands upon thousands flocked to see them off, and roared their God-speed with cheery British lungs, albeit with sad and anxious hearts.

[Pg 7]

THE OCCUPATION OF DUNDEE

Late in September a force consisting of two battalions of infantry, a regiment of cavalry, and two field-batteries was hurriedly pushed forward to occupy Dundee. Affairs between the British and the Boers were nearing a crisis. It was beginning to be believed that the Dutchmen meant to take the initiative and strike a blow against our supremacy in South Africa, though some at home were still shilly-shallying with sentimental arguments as to the propriety of fighting our "brother Boer" at all. As we now know, it wanted but the smallest move on the part of the British to bring things to a head. Large commandoes were gathered together with a rapidity which would have been marvellous had the Boers not designedly brought about the issue of war, and the frontier of the northern angle of Natal was threatened. Dundee is an important coal-mining centre situated some forty-eight miles north-east of Ladysmith. Why it was chosen as our advance post is hard to decide. Its communications with Ladysmith were open to attack from either flank, and, in the light of after events, we see that the position there of a detached force was highly precarious. General Sir George White in an official despatch thus describes his action in the matter:—

"Since my arrival in the Colony I had been much impressed by the exposed situation of the garrison of Glencoe, and on the evening of October 10 I had an interview on the subject with his Excellency the Governor, at which I laid before him my reasons for considering it expedient, from a military point of view, to withdraw that garrison, and to concentrate all my available troops at Ladysmith. After full discussion his Excellency recorded his opinion that such a step would involve grave political results and possibilities of so serious a nature that I determined to accept the military risk of holding Dundee as the lesser of two evils. I proceeded in person to Ladysmith on October 11, sending on Lieutenant-General Sir William Penn Symons to take command at Glencoe.

[Pg 8]

"The Boers crossed the frontier both on the north and west on October 12, and next day the Transvaal flag was hoisted at Charlestown. My great inferiority in numbers necessarily confined me strategically to the defensive, but tactically my intention was, and is, to strike vigorously whenever opportunity offers."

Everything at this juncture depended on the rapidity with which our army at home could be mobilised and sent to the Cape, and though we took to ourselves some credit for the energy displayed by all concerned, we were really scarcely up to date in the matter of activity. For instance, in 1859 it took only thirty-seven days for France to collect on the river Po a force of 104,000 men, with 12,000 more in Italy, while in 1866 the Prussian army, numbering 220,000 men, were placed on the frontiers of Saxony and Silesia in a fortnight. But more expeditious still was Germany in 1870. In nine days she was able to mobilise her forces, and in eight more to send

to the French frontier an army of 400,000 soldiers and 1200 guns! We had, it is true, to ship off our troops a distance of some 8000 miles, but, without counting this—a natural disadvantage—there were others—many others, the upshot of red-tapism—to be contended with. This Sir George White was beginning to feel, but his sufferings in regard to the initial delay were threefold later on.

To return to Dundee. It was maintained both by the Government and the people of Natal that the valuable coal supply should be protected, and an attempt was therefore made to guard it. The misfortune was that from the first Lieutenant-General Sir W. Penn Symons—who, before the arrival of Sir George White, commanded in Natal—seemed to be ill acquainted with the enormous forces that the Boers could bring to bear against him. It was true that he could not at that time be certain, any more than appeared to be the Government at home, that the Free Staters would join the Republicans; but to any one acquainted with the subject, the fact that President Steyn had pulled the strings of the Bloemfontein affair was sufficient evidence of a contemplated alliance. With the Free State neutral, the aspect of affairs might have been entirely changed, and Dundee, with Ladysmith to support it, might have held its own. As it was, these small places were from the first placed in the most unenviable quandary.

General Symons, on the arrival of Sir George White in Natal, took command of the forces in Dundee, and began active preparations for the reception of the Dutchmen.



**MAP OF NORTHERN NATAL. SCALE
15 STATUTE MILES TO THE INCH.**

The latter, immediately after the declaration of war, took possession of Newcastle, and our patrols soon came in touch with the enemy. In spite of their animated and aggressive movements, however, Sir W. Penn Symons was disinclined to believe that the enemy meant a serious attack upon Dundee, and though fully prepared for hostilities, he was somewhat amazed when really informed of the rapid advance of the united Republicans. But he lost no time. He made inquiries, and satisfied himself that he was in a position of some danger and that he must promptly leap to action. The chief difficulty of the situation lay in the number of passes through which the Boers with their easily mobilised forces could manage to pour in bodies of men, and the limited number of British troops at General Symons's disposal. From the movements of the Boers it was obvious that the plan of attack had long been cleverly and carefully arranged. The Free State Boers on the 12th of October seized Albertina Station, near the Natal frontier, and took possession of the key, the stationmaster having to make his way on a trolley to Ladysmith. There, as yet, all was externally peaceful, as though no enemy were near, but a suppressed anxiety to be "up and at 'em" prevailed among the troops. Their ardour was in nowise damped by the incessant rain that fell, and converted the surrounding country into a wide morass, nor by the snow that followed, which gave the Drakensberg Mountains an additionally impregnable aspect and rendered them at once picturesque and forbidding.

[Pg 10]

A steady increase of the commandoes in the neighbourhood of Doornberg continued, and an attack within a few days seemed imminent.

Thereupon a large number of troops left Ladysmith for Acton Homes, where a Boer commando of four miles long was reported to be laagered. But the Boers retreated, and the troops remained some ten miles from Ladysmith, the Dublin Fusiliers alone moving back to Glencoe, whence they had come by train by order of General Symons.

At Glencoe we had, as before stated, some 4000 men, but report said that General Viljeon had an enormous force, nearly double ours in number, which was lying at the foot of Botha's Pass, one and a half miles on the Natal side of the Border. Besides this, General Kock had a commando at

Newcastle. The invasion of Natal by the Boers in three columns was formally announced by an official statement from the Governor:—

"PIETERMARITZBURG, *October 16.*

"Natal was invaded from the Transvaal early on the morning of the 12th inst., an advance being made by the enemy in three columns. On the right a mixed column of Transvaal and Free State Burghers with Hollander Volunteers marched through Botha's Pass. In the centre the main column, under General Joubert's personal command, crossed Lang's Nek and moved forward *viâ* Ingogo. On the left a large commando advanced from Wakkerstroom *viâ* Moll's Nek and Wool's Drift. The object of all three columns was Newcastle, which was occupied on the night of the 14th, the central column having slept the previous night at Mount Prospect, General Colley's old camping-place. On Sunday an advance party of 1500 Boers, with artillery, pushed south of Ingagane, but the greater portion of this commando retired later in the day on Newcastle. A Boer force which had been concentrating at De Jager's Drift captured six Natal policemen. A picket of the King's Royal Rifles Mounted Infantry has exchanged a few shots with the enemy. This has hitherto been the only fighting.

[Pg 11]

"A large force of Free State Boers, estimated at from 11,000 to 13,000, is watching the passes of the Drakensberg from Olivier's Hoek to Collins's Pass. They have pushed a few patrols down the berg, but hitherto the main force has not debouched from the actual passes, which are being intrenched."

As will be seen, the advance of the foe seemed to be converging on Sir George White's position from all directions, and threatening Glencoe from the north, east, and possibly west. Still the troops remained cheerful and looked forward to a brush with the enemy. On the 18th hostilities were begun by the Free State commando moving about ten miles down the Tintwa Pass. They opened fire with their artillery on some small cavalry patrols, but their shooting was distinctly inferior, and no one was injured. They retreated on the advance of the 5th Lancers. Several more commandoes were known to have advanced to join a force stationed at Doornberg, some twelve miles from Dundee, and the enemy's scouts having also been seen some seven miles off Glencoe, an engagement was expected at any moment. An interesting account of this interval of suspense was given by an officer writing on the 16th October from Dundee, interesting and pathetic, too, when, in reading it, we remember that the gallant fellow to whom the writer alluded is alive no longer. He said:—

"Hitherto there has been no fighting at all, but our patrols are in touch with the enemy. I was out on my first patrol the day before yesterday since the declaration of war. My orders were to start at 6 A.M., push on about twelve miles along the Newcastle road, and stay out till about 6 P.M. I went out to a small hill about four miles from the camp and reconnoitered, and then went on to a place called Hadding Spruit, where I found a few people at the station and the stationmaster. This is at present the terminus of the line, all the rolling stock north of this having been sent south, and all the wires cut and instruments removed by the railway people. There is a large coal-mine here, and the people are in a deadly funk about being blown up. I pushed on to a large kopje, a few miles this side and west of Dannhauser, and climbed to the top, where I spent an hour or so, as from there one can see as far as Ingagane Nek, four miles this side of Newcastle, the place I sketched. Just as I looked over the top of the hill I saw two men on ponies with guns. They were talking to a Kaffir. I at once put them down as Boers, and thought of firing at them, but decided not to disclose my position and watch them. This was lucky for them, as I caught them later, and found them to be refugees flying from the Boers, who I discovered were in occupation of Ingagane and Newcastle, and had their patrols out nearly to Dannhauser.

[Pg 12]

"I then went on to Dannhauser, which consists of a railway station, two farms, a store, a couple of coolie stores, a mine, and a few huts. We approached with magazines charged and expected to see a Boer every minute, but found that they were not expected to come down as far as that till next day. I then made my way slowly back by the main road, and reached camp about 5 P.M., when I found that the other patrol (six men and an officer is the strength of each) had proceeded to De Jager's Drift and had not returned. A telephonic communication from the police-station at De Jager's Drift said, 'A large force of forty Boers have crossed Buffalo to cut off your patrol. Am trying ...'—and then ended abruptly. It eventually transpired that the Boers rushed the police-station before the message could be completed. Thackwell, who was in command of the patrol, pursued twelve Boers up to the river. Then thirty-four crossed to our side, and twelve lower down, the twelve trying to cut him off behind. However, he retired on to a nek behind, and as they did not come on, he moved off in about half an hour by another road. This was lucky for him, as he saw the twelve men who had crossed by Landsman's Drift disconsolately coming down from a lot of rocks where they had been lying in wait for him on the road he had come by.

"There seems to have been something going on at Kimberley. I wish they would buck up here and do something. I am on picket to-night, which means no sleep and a lot of bother, as the picket is about seven miles from camp at the junction of the Vant's Drift and De Jager's Drift roads, where there is a chance of being plugged at. The picket on the Helmakaar road was shot at the other night.

"One of the armoured trains came up here yesterday—an ugly-looking beast with the engine in the middle, all covered with iron, so that only just the top of the funnel is visible. I do not believe in them. If any one puts a dynamite cartridge under a rail—pop! up goes the armoured train.

"I think this will be a very interesting war, as the railway will play such an important part in the

tactics. Thus the other day we sent the Dublin Fusiliers down to Ladysmith to repel an expected attack at half-an-hour's notice, and brought them back the same night.... [Pg 13]

"We are under an awfully nice General—one Penn Symons—a real good chap."

On the 18th of October the Carabineers were in touch with the enemy in the neighbourhood of Bester's Farm a great part of the day, and Lieutenant Galway, son of the Chief-Justice of Natal, who remained to watch his troops off the kopje, was reported missing. The Carabineers were compelled to retire owing to being completely outnumbered by the Boer force, and had they not done so they would have run the risk of being cut off from their supports. There were some hair-breadth escapes, and Major Taunton, who was riding at the head of his squadron, came through a vigorous hail of bullets quite uninjured.

Major Rethman, in command of 300 Natal Mounted Rifles, also actively engaged the enemy near Acton Homes, but was also compelled to retire for fear of being cut off. Being quite conversant with Boer tactics, he refused to be drawn by the pretence of retreat made by the Dutchmen, knowing that concealed forces of the enemy in great numbers were waiting to entrap him. Major Rethman, believing in the old saw that brevity is the soul of wit, reported his loss as "one hat."

The Dutchmen now advanced. An armoured train, sent by Sir George White to bring in wounded from Bester's Farm, returned discomfited, as the rails over the bridge four miles off Ladysmith had been tampered with. It was found that a farm, which had been deserted earlier in the day, was now in the occupation of the Boers, but these, though established on the south side of the line, made no effort to attack the train and allowed it to return unmolested. Rumours of fighting were in the air, and skirmishes between advance parties of British troops and Boers were the order of the day. A report reached the Glencoe camp that the Boers had been seen some seven miles off, whereupon Major Laming with a squadron of the 18th Hussars rode out to reconnoitre. Lieutenant Cape, the advanced officer's patrol, discovered a strong advance party of the enemy, who delivered a heavy fire, but fortunately without result. This most probably was due to the swift and clever manœuvring of the Hussars.

The Carabineers and Border Mounted Rifles, who were in action nearly the whole of the 18th of October, returned to camp at three in the morning of the 19th. They were quite worn out and famished, having been for twenty-four hours without food, and three days and two nights in the saddle. Considering the excitement and fatigue, they were in excellent spirits. Their experience was a novel one, for on this occasion the Boers, who usually prefer to skulk under cover, made incipient rushes at certain points. They gave way, however, before the pressing attentions of the Maxims, and fled helter-skelter to cover again; but their departure was on the principle of "those who fight and run away live to fight another day." They reserved themselves for a more decisive effort. [Pg 14]

At midday on the 19th a mixed train running from Ladysmith to Dundee was captured by the enemy about a mile off Elandslaagte Station, which stands about fifteen miles from Ladysmith, and is the first station from thence on the line. A war correspondent was taken prisoner, four Carabineers were wounded, and some horses and cattle seized. Telegraphic communication in the north was cut off, and four trucks of stores in the Elandslaagte Station were captured.

THE BATTLE OF GLENCOE

On the night of the 19th, Sir W. Penn Symons discovered that he was surrounded by the enemy. Three of their columns were converging on his position—one from the north-west under General Erasmus by the Dannhauser-Hattingspruit road; one from Utrecht and Vryheid by Landsman's Drift from the east, under Commandant Lucas Meyer; and a third under General Viljoen from Waschbank on the south, this latter being the force which cut through the Ladysmith-Dundee railway.

The Boer plan was to deliver simultaneously different attacks from all sides of the Glencoe camp. The column under Erasmus was to open the attack from the north-west, and falling back, was to draw Symons in pursuit away from his camp. Then Viljoen and Meyer were to close on the pursuers from either flank and annihilate them.

Fortunately this skilfully-devised programme was not fulfilled. For this reason: The force under Lucas Meyer was the first to arrive, and its leader, impatient to secure the glories of war, decided on an independent course of action. Before the other columns could put in an appearance he opened the attack. On the hills round Glencoe the Boers had posted cannon, and from thence at daybreak on the 20th of October Meyer's gunners began to fire plugged shells into the camp. A flash—a puff of smoke—a whizz and a crash! Hostilities had begun! By 5 P.M. all General Symons's troops were under arms. It was evident that the enemy were in force, and that their guns were some half-a-dozen in number. Their range was 5000 yards, but, fortunately, their shots, though well directed, flew screaming overhead and buried themselves in the soft earth, doing no damage whatever. A few tents fell, a few marquees were torn up. That was all. Our artillery soon came into action, at first at too long a range, but afterwards—from a position south of Dundee—with greater success. They then replied to the enemy's challenge with considerable warmth and excellent effect; and, since our batteries numbered some three to one, by 11.30 o'clock the enemy's Krupps were silenced. In the meantime the infantry, the 1st King's Royal Rifles and the 2nd Dublin Fusiliers, formed for attack opposite the enemy's position, which was situated some [Pg 15]

two miles off at the top of an almost impregnable hill. Huge boulders margined the sides of it, and half-way up an encircling wall added to the impassability of the position. But the word impossible is not to be found in the dictionary of a soldier, and General Symons gave an order. The hill was to be taken. The bugles rang out; the infantry fixed bayonets. Then was enacted another, only a grander, Majuba, but now with the position of the contending forces inverted. Doubtless the memory of that historic defeat inspired our men, for they evidently decided that what the Boer had done, the Briton also could do, and, spurred by their officers, who showed an absolute disregard of the possibilities of danger, went ahead and carried the crest in magnificent style. No such brilliant achievement of British infantry has been recorded since Albuera. But this, as we shall see, was not accomplished in a moment. It involved tremendous exposure in crossing an open plain intersected with nullahs under a terrific fire, followed by a long spell of dogged climbing, finally on hand and knees, over more than a mile of broken, sometimes almost perpendicular, ground, and in the midst of an incessant and furious fusilade.

At 7.30 A.M. the head of the Hattingspruit column appeared; appeared but to vanish—for it was at once saluted by the 67th Field Battery, and being unprepared for this somewhat boisterous attention, made haste to beat a retreat. At 8.50 the infantry brigade was ordered to advance. Soon the Dublin Fusiliers and the Rifles, who had been reinforced by the Royal Irish Fusiliers, were steadily moving on, firing by sections, and using what cover the ground afforded. Overhead, from the hill described, and from another south of the road, the ever-active shells continued their grim music, while all around was the dense curtain of fine rain that drizzled down like wet needles from an opaque sky, making a screen between the opposing forces. But on and on, led by their gallant officers, our infantry continued to toil, their advance ever covered by the 13th and 67th Field Batteries—under the command respectively of Major Dawkins and Major Wing—while the enemy from above poured upon them volley after volley as hard as rifles would let them. When half-way up, where the kopje was girded by a flat terrace and a stone wall, the troops, scattered by the terrific fire, hot, drenched, and panting with their climb, made a halt. There, under the lea of the hill, it was necessary to get "a breather," and to gather themselves together for the supreme effort. The scene was not exhilarating. The grey mist falling—the scattered earth and mud rising and spluttering, the shrieking shells rending the air, already vibrant with the whirr of bullets—the closer sounds and sights of death and destruction—all these things were sufficient to stem the courage of stoutest hearts. Still the British band remained undaunted, still they prepared boldly for the final rush. Presently, with renewed energy the three gallant regiments, steadily and determinedly as ever, started off, scaled the wall, clambered up the steep acclivity, and finally, with a rush and a roar as of released pandemonium, charged the crest.

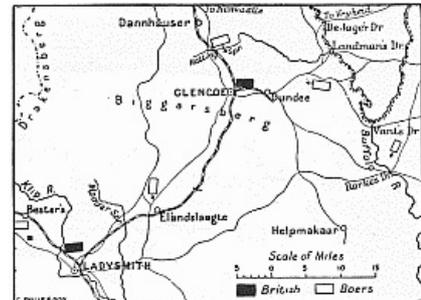

POSITION OF FORCES BEFORE THE BATTLE OF GLENCOE.

[Pg 16]

The rout of the enemy was complete. At the glint of the steel they turned and ran—ran like panic-stricken sheep, helter-skelter over the hill, in the direction of Landmann's and Vant's Drifts. Their retreat was harried by cavalry and mounted infantry, and, so far as it was possible, in view of the inaccessible position, by the field artillery. At this juncture the enemy displayed a white flag—without any intention of surrender, it appears—but our firing was stopped by order of the artillery commander. Two guns and several prisoners were captured, together with horses and various boxes of shells for Maxim, Nordenfeldt, and Krupp quick-firing guns. Our wounded were many, and some companies looked woefully attenuated as the remnant, when all was over, whistled themselves back to camp. Their gallant leader, General Penn Symons, who had taken no precautions to keep under cover, but, on the contrary, had made himself conspicuous in being accompanied by a lancer with a red flag, fell early in the fight, mortally wounded. His place was taken by Brigadier-General Yule, whose position at that time was far from enviable. A message had been brought in by scouts, stating that some 9000 Boers were marching with the intention of attacking the British in the rear, and that at the very moment the advancing multitude might be cloaked in a dark mist that was gathering round the hills. Fortunately the hovering hordes failed to appear, and the first big engagement of the war terminated in a glorious victory for British arms.

[Pg 17]

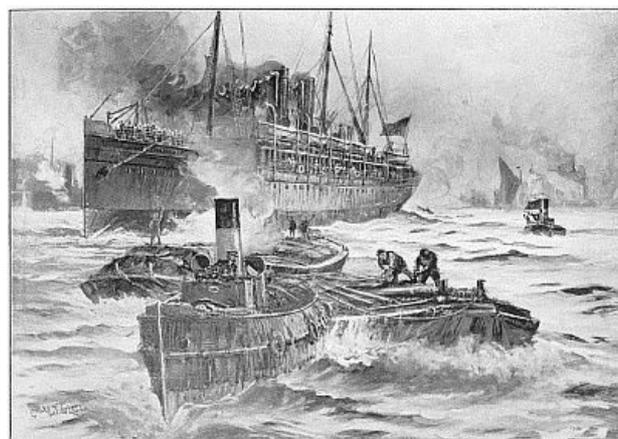

THE OUTBREAK OF THE WAR— TRANSPORT LEAVING ENGLAND FOR THE CAPE.

Drawing by Charles J. de Lacia.

From all accounts the two hostile columns numbered respectively 4000 and 9000 men, and against these forces Sir Penn Symons had at his command in all about 4000. Among these were the 13th, 67th, and 69th Field Batteries, the 18th Hussars, the Natal Mounted Volunteers, the 8th Battalion Leicester Regiment, the 1st King's Royal Rifles, the 2nd Dublin Fusiliers, and several companies of mounted infantry. But on the Dublin Fusiliers, the King's Royal Rifles, and the Royal Irish Fusiliers fell the brunt of the work, the task of capturing the Boer position, and the magnificent dash and courage with which the almost impossible feat was accomplished brought a thrill to the heart of all who had the good fortune to witness it.

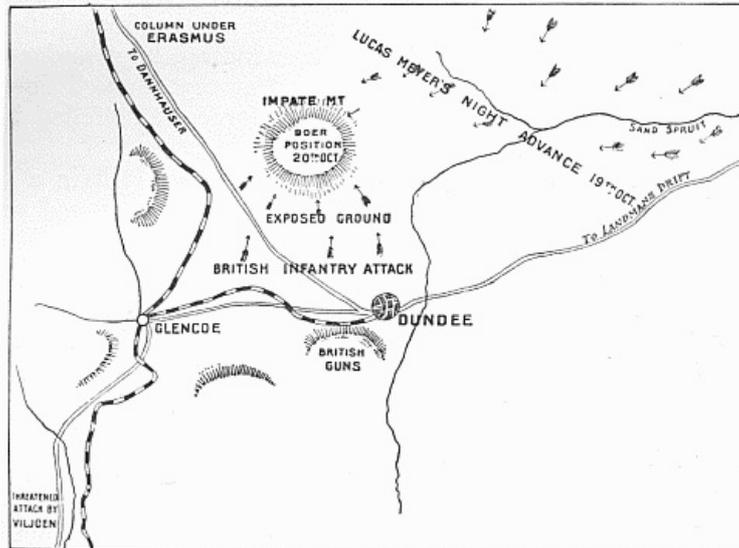

Though the fight was a successful one, a grievous incident occurred. The 18th Hussars had received orders at 5.40 A.M. to get round the enemy's right flank and be ready to cut off his retreat. They were accompanied by a portion of the mounted infantry and a machine-gun. Making a wide turning movement, they gained the eastern side of Talana Hill and there halted, while two squadrons were sent in pursuit of the enemy. From that time, though firing was heard at intervals throughout the day, Colonel Moeller, with a squadron of the 18th Hussars and four sections of mounted infantry, was lost to sight. The rain had increased and the mist covered the hills, and it was believed that in course of time this missing party would return. But the belief was vain. In a few days it was discovered that they were made prisoners and had been removed to Pretoria. The following is a list of the gallant officers who were so unluckily captured:—

[Pg 18]

Colonel Moeller, 18th Hussars; Major Greville, 18th Hussars; Captain Pollok, 18th Hussars; Captain Lonsdale, 2nd Battalion Dublin Fusiliers; Lieutenant Le Mesurier, 2nd Battalion Dublin Fusiliers; Lieutenant Garvice, 2nd Battalion Dublin Fusiliers; Lieutenant Grimshaw, 2nd Battalion Dublin Fusiliers; Lieutenant Majendie, 1st Battalion King's Royal Rifle Corps; Lieutenant Shore, Army Veterinary Department, attached to 18th Hussars.

An official account of the circumstances which led to the capture was supplied by Captain Hardy, R.A.M.C., who said: "After the battle, three squadrons of the 18th Hussars, with one Maxim, a company of the Dublin Fusiliers, a section of the 60th Rifles and Mounted Infantry, Colonel Moeller commanding, kept under cover of the ridge to the north of the camp, and at 6.30 moved down the Sand Spruit. On reaching the open the force was shelled by the enemy, but there were no casualties.

"Colonel Moeller took his men round Talana Hill in a south-easterly direction, crossed the Vant's Drift road, captured several Boers, and saw the Boer ambulances retiring. Colonel Moeller, with the B Squadron of the Hussars, a Maxim, and mounted infantry, crossed the Dundee-Vryheid railway, and got near a big force of the enemy, who opened a hot fire, and Lieutenant M'Lachlan was hit.

"The cavalry retired across Vant's Drift, 1500 Boers following. Colonel Moeller held the ridge for some time, but the enemy enveloping his right, he ordered the force to fall back across the Spruit. The Maxim got fixed in a donga (water-hole). Lieutenant Cape was wounded, three of his detachment were killed, and the horses of Major Greville and Captain Pollok were shot.

"The force re-formed on a ridge north of the Sand Spruit, and held it for a short time. While Captain Hardy was attending to Lieutenant Crum, who was wounded, Colonel Moeller retired his force into a defile, apparently with the intention of returning to camp round the Impati Mountain, and was not seen afterwards."

The following list of casualties shows how hardly the glory of victories may be earned:—

Divisional Staff.—General Sir William Penn Symons, mortally wounded in stomach; Colonel C. E. Beckett, A.A.G., seriously wounded, right shoulder; Major Frederick Hammersley, D.A.A.G., seriously

wounded, leg. Brigade Staff.—Colonel John Sherston,^[1] D.S.O., Brigade Major, killed; Captain Frederick Lock Adam, Aide-de-Camp, seriously wounded, right shoulder. 1st Battalion Leicestershire Regiment.—Lieutenant B. de W. Weldon, wounded slightly, hand. 1st Battalion Royal Irish Fusiliers.—Second Lieutenant A. H. M. Hill, killed; Major W. P. Davison, wounded; Captain and Adjutant F. H. B. Connor, wounded (since dead); Captain M. J. W. Pike, wounded; Lieutenant C. C. Southey, wounded; Second Lieutenant M. B. C. Carbery, wounded dangerously, face and shoulder; Second Lieutenant H. C. W. Wortham, wounded severely, both thighs. Royal Dublin Fusiliers.—Captain George Anthony Weldon, killed; Captain Maurice Lowndes, wounded dangerously, left leg; Captain Atherstone Dibley, wounded dangerously, head; Lieutenant Charles Noel Perreau, wounded; Lieutenant Charles Jervis Genge, wounded (since dead). 1st Battalion King's Royal Rifles.—Killed: Lieutenant-Colonel R. H. Gunning,^[2] Captain M. H. K. Pechell, Lieutenant J. Taylor, Lieutenant R. C. Barnett, Second Lieutenant N. J. Hambro.—Wounded: Major C. A. T. Boulton, upper thigh, dangerously; Captain O. S. W. Nugent, Captain A. R. M. Stuart-Wortley, Lieutenant F. M. Crum, Lieutenant R. Johnstone, both thighs, severely; Second Lieutenant G. H. Martin, thigh and arm, severely. 18th Hussars.—Wounded: Second Lieutenant H. A. Cape, Second Lieutenant Albert C. M'Lachlan, Second Lieutenant E. H. Bayford.

[Pg 19]

The Boer force engaged in this action was computed at 4000 men, of whom about 500 were killed, wounded, or taken prisoners. Three of their guns were left dismounted on Talana Hill, but there was no opportunity of bringing them away.

Our own losses were severe, amounting to 10 officers and 31 non-commissioned officers and men killed, 20 officers and 165 non-commissioned officers and men wounded, and 9 officers and 211 non-commissioned officers and men missing.

[Pg 20]

Though General Symons was known to be at the point of death, his promotion was speedily gazetted, and it was some consolation to feel that the gallant and popular officer lasted long enough to read of the recognition of his worth by an appreciative country. The following is an extract from the *Gazette*:—

"The Queen has been pleased to approve of the promotion of Colonel (local Lieutenant-General) Sir W. P. Symons, K.C.B., commanding 4th Division Natal Field Force, to be Major-General, supernumerary to the establishment, for distinguished service in the field."

An officer who was taken prisoner by the enemy, writing home soon after this engagement, made touching reference to some of the killed and wounded: "Poor Jack Sherston! Several of the officers here saw him lying dead on the hill at Dundee. When he left with the message entrusted to him he said to me, 'I shall never return.' Poor Captain Pechell! He had a bullet through the neck. General Symons was wounded and thrown from his horse, but he remounted and was conducted to the hospital, where he learnt that the height had been taken by our troops. His health improved a little, but he died on the following Tuesday. What a list of losses already! It is terrible to think that our own cannon were fired by mistake on our men, killing a large number. I saw M'Lachlan when he was wounded with a bullet in his leg. He went about on horseback saying that it did not hurt him, but at last he had to go to the hospital. My bugler, such a pleasant fellow, was hit in the head, the body, and the throat, and killed on the spot.... From a wounded officer, who is a prisoner, I hear that poor Cape had a bullet in the throat and another in the leg. He emptied his revolver twice ere falling. He is progressing towards recovery.... He had the command of our Maxim gun which fell into the hands of the enemy. The entire detachment which worked the gun was killed or wounded. At that moment bullets were whistling all round us. Cape, I think, has been exchanged for one of the enemy's wounded. I suppose that he will be sent home invalided. I wonder what the future has in store for us? It is really heart-breaking to think that we are penned in here without being able to do anything but wait."

ELANDSLAAGTE

Amongst other things, it was known in Ladysmith on the 18th of October that General Koch's commando was moving to the Biggarsberg Pass on the way to Elandslaagte. The advanced guard of the Boers finding a train at the Elandslaagte station, attempted to seize it, but the driver with remarkable pluck turned on steam, and, though pelted with bullets, got safely to Dundee. The second train was captured, however, and with it its valuable cargo of live stock, and two newspaper correspondents, who were made prisoners. Finding that the enemy was gathered in force round Dundee, and that an attack there was hourly to be expected, and, moreover, that several Free State commandoes were shifting about round Ladysmith, the inhabitants of that town had an uneasy time. Major-General French, who had but recently arrived from England, was directed by Sir George White to make a reconnaissance in force in the neighbourhood of Elandslaagte. He moved his cavalry in the pouring rain some twelve miles along the Dundee road, but besides locating the enemy, and beyond the capture of two of their number, who seemed not ill-disposed to be made prisoners, little was done. On the following day, Saturday, another reconnaissance was made. General French with Lieutenant-Colonel Scott Chisholme and the Imperial Light Horse, the Natal Volunteer Artillery with six guns, supported by half a battalion of the Manchesters, with railway and telegraph construction companies, started in the direction occupied by the enemy on the preceding day. General French's orders were simple and explicit, namely, to clear the neighbourhood of Elandslaagte of the enemy and to cover the construction of the railway and telegraph lines. The troops slowly proceeded along a low tableland which terminated in a cliff. On a plain below this cliff lay the station and village of Elandslaagte, and round and about this settlement mounted Boers were swarming. These no sooner espied the British than they made off as fast as their nimble steeds could carry them,

[Pg 21]

ascending in the direction of a high kopje some 5000 yards away. Those who remained in the station were fired on by our Volunteer Battery, while a squadron under Major Sampson moved round to the north of them.

The first two shells caused considerable consternation among the Dutchmen, but they were soon returned with interest. Though the enemy used smokeless explosives, their battery was revealed by the yellow flash of the guns in the purple shadow of the hill. These guns were worked with marvellous accuracy, but, fortunately, many of the shells—fired with percussion fuses—dug deep into the sand before bursting. The Volunteer Battery found their own guns so inferior to those of the enemy that there was little chance of silencing them, and General French, seeing there was no question of occupying Elandsplaagte with the small force at his disposal, moved his guns back towards his armoured train, telephoned to Sir George White, and withdrew in the direction of Modder's Spruit. There he awaited reinforcements from Ladysmith.

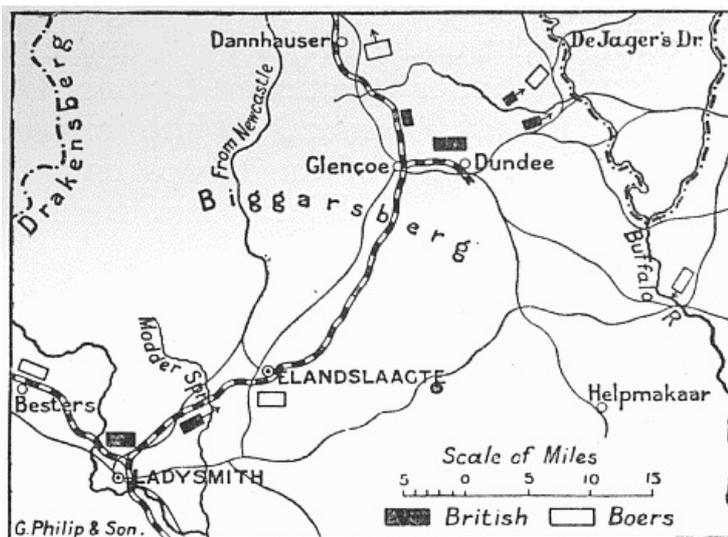

POSITION OF FORCES BEFORE THE BATTLE OF ELANDSLAAGTE, NOON

These at 11 o'clock began to appear: One squadron of the 5th Dragoon Guards, one squadron of the 5th Lancers under Colonel King, and two batteries of artillery, the latter having come out at a gallop with double teams. Then the infantry arrived under Colonel Ian Hamilton, the second half-battalion of the Manchester Regiment, a battalion of the Devonshire Regiment under Major Park, and five companies of the Gordon Highlanders under Lieutenant-Colonel Dick-Cunyngham, V.C.

At 3.30 P.M. General White arrived on the scene, but the executive command of the troops engaged remained in the hands of General French. The Boers were discovered to be magnificently posted on a horseshoe-shaped ridge about 800 feet above the level of the railway to north of the Ladysmith-Dundee road, standing almost at a right angle from the permanent way, though some 2000 yards removed from it. On the side nearing the railroad the ridge was crowned with a peaked kopje, which hill was connected by a nek with another eminence of the same kind. These hills were held by the enemy, while their laager was situated on the connecting ridge. The position was strewn on both flanks by very rough boulders which afforded excellent cover. On the main hill were three big guns strongly posted at three different points so as to command a wide expanse of country and leave a retreat open over the hills in the direction of Wessel's Nek. Facing the ridge was a wide expanse of veldt rising upwards in the direction of Ladysmith.

At four—an unusually late hour for the commencement of hostilities—the first gun boomed out; the range was 4400 yards. A few moments of furious cannonading, then the enemy's guns ceased to reply. The silence enabled the artillerymen to turn their attention on a party of the foe who were annoying them with a persistent rifle-fire on the right flank at a range of 2000 yards. It was an admirable corrective, and the Boer sharpshooters retired discomfited. Meanwhile the infantry had been brought up in preparatory battle formation of small columns covered by scouts. The position of the infantry was then as follows:—

The first battalion Devonshire Regiment, with a frontage of 500 yards and a depth of 1300 yards, was halted on the western extremity of a horseshoe-shaped ridge. The opposite end of this ridge, which was extremely rugged and broken, was held by the enemy in force. The first battalion Manchester Regiment had struck the ridge fully 1000 yards to the south-east, just at the point where it begins to bend round northwards. The second battalion Gordon Highlanders were one mile in rear.



**LIEUT.-GENERAL J. D. P.
FRENCH.**

**Photo by Lambert Weston & Son,
Folkestone.**

Now, no sooner had the Devonshire Regiment commenced to move forward than they attracted the shell of the enemy, but owing to the loose formation adopted, the loss at this time was slight. In spite of the furious fire, the regiment still pushed on to within 900 yards of the position, and then opening fire, held the enemy in front of them till 6 P.M. The batteries also advanced and took up a position on a ridge between the Devonshire and Manchester Regiments, about 3200 yards from the enemy. Then began an animated artillery duel, the roar of guns mingling with the thunder of heaven, which at this juncture seemed to have attuned itself to suit the stormy state of the human tempest that was raging below. At this period considerable damage was done. Captain Campbell, R.A., was wounded, an ammunition waggon overturned, and many men and horses were killed or injured. For some time the interchange of deadly projectiles was pursued with vigour, then the 42nd Field Battery came into action. The Imperial Light Horse now moved left of the enemy's position; some mounted Boers at once pushed out and engaged them. Soon after this the guns from above ceasing firing, our gunners turned their attention to the mounted Boers, who rapidly fell back. Then, as the sun was setting and dark clouds were rolling over the heavens and screening the little light that remained, the infantry pressed forward. The plan was that while the Devonshire Regiment made a frontal attack, the Manchester Regiment, supported by the Gordons with the Imperial Light Horse on the right, were to advance along the sloping ridge, turn the enemy's flank and force him back on his main position. This movement was to be supported by the artillery, which was to close in as the attack developed.

The Devons, under Major Park, marched out, as said, leading the way across the plateau and into the valley coolly and deliberately, though under a terrific fire from above. The Boer guns, which were served with great courage, invariably gave tongue on the smallest provocation, and the ground was ploughed up in every direction with bursting shell. But fortunately few of the gallant Devons were hit. Later on they drew nearer the position, and the regiment, halted under cover of convenient ant-hills, and opened fire. The rifles of the enemy were not slow to reply. Their Mauser bullets whirred like swarms of bees around the heads of the plucky fellows, who, heedless of them, dauntlessly advanced to within some 350 yards of the summit of the hill. There they awaited the development of the flank attack.

[Pg 24]

Meanwhile the Manchesters, with the Imperial Light Horse and the Gordons, were winding round the lower steps, the Gordons bearing to the right through a cutting in the hills. Here, ascending, they came under the artillery fire of the enemy, the Boers having moved their guns. Shells, and not only shells but huge boulders, dropped among the advancing troops, crushing and mutilating, and leaving behind a streak of mangled bodies. But though the ordeal was terrible, and the sound and sight of wounded and bleeding were enough to paralyse the stoutest heart, the ever "gay" Gordons plodded on, passing higher and higher, while their officers leading, cheered and roared them up the precipitous ascent. Thus they clambered and plodded, with men dropping dead at their elbows, with torn and fainting comrades by their sides. A storm of rain from the gathering thunderclouds drenched them through to the skin, but they heeded it not. A storm of bullets from the Boers sensibly diminished their numbers, but they never swerved. Then their gallant commander fell. Colonel Dick-Cunyngham, the honoured and beloved, was shot in two places. Several other dashing Scottish officers were wounded, but many still heroically stumbled and reeled over the boulders, some even waving their helmets to pretend they were unhurt, and to encourage their companions to the great, the final move....

At last the signal for the charge was sounded. The bugle blared out and was echoed and re-echoed. Then came flash of bayonet and sound of cheering throats, the rush of Devons,

Manchesters, Gordons, and dismounted Imperials—a wild, shouting mass making straight for the enemy's position.

To account for the presence of the Devons in the grand melée it is necessary to go back somewhat, as the great assault was not accomplished in a moment.

Our men were advancing in short rushes of about fifty yards, the Boers all the while lying under cover and shooting till the troops were within some twenty or thirty yards of them. Then the Dutchmen, as suited their convenience, either bolted or surrendered.

When the end ridge was gained and the guns captured, the enemy's laager was close in sight. A white flag was shown from the centre of the camps. At this Colonel Hamilton gave an order. The "Cease fire" was sounded. There was a lull in the action, some of our men commencing to walk slowly down-hill towards the camp. Suddenly, without warning, the crackle of musketry was heard, and a deadly fire poured from a small sugar-loaf shaped kopje to east of the camp. For one short moment our men, staggered by the dastardly action and the fierce suddenness of the attack, fell back, and during this moment a party of some forty Boers had stoutly charged uphill and effected a lodgment near the crest.

[Pg 25]

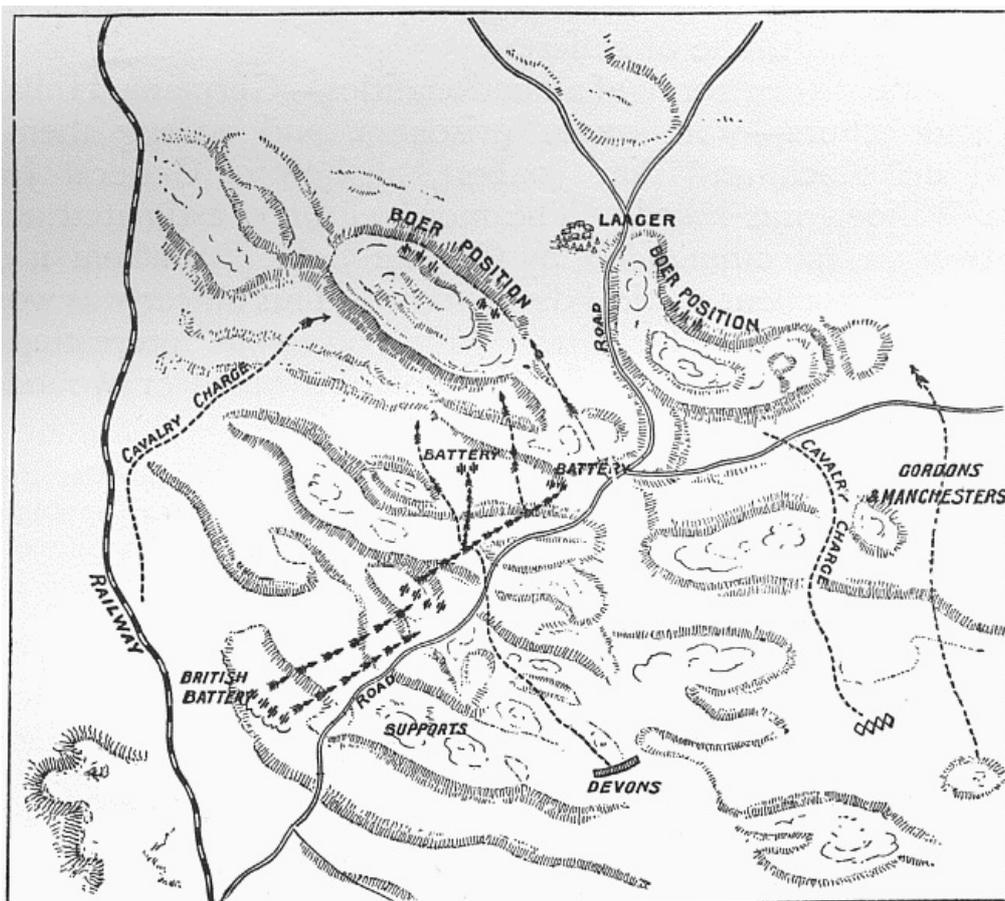

PLAN OF BATTLE OF ELANDSLAAGTE

But this ruse was a failure and their triumph short-lived. The 1st Battalion Devonshire Regiment, who, as we know, had been holding the enemy in front during the commencement of the infantry attack, and had since then pushed steadily forward, had now reached to 350 yards from the enemy. Here they lay down to recover breath before charging with fixed bayonets. Five companies assaulted the hill to the left and five to the right; and a detachment of these, arriving at the critical moment when the Boers were making their last stand, helped to bring about the triumphant finale.

Like the lightning that shot through the sky above, the Boers, at the sound of the united cheers, had fled! Some scampered away to their laager on the Nek, and from thence to other kopjes. Others filed in troops anywhere, regardless of consequences. While they were in full retreat, and the mists of darkness, like a gathering pall, hung over the scene, the 5th Lancers and the 5th Dragoon Guards charged the flying enemy—charged not once nor twice only, but thrice, dashing through the scattered ranks with deadly purpose, though at terrible risk of life and limb. Never were Boers so amazed. The despised worms—the miserable Rooineks—had at last turned, and, as one of them afterwards described it, they had "come on horses galloping, and with long sticks with spikes at the end of them, picked us up like bundles of hay!"

[Pg 26]

The cost of victory, however, was heavy. Roughly estimated, we lost 4 officers and 37 men killed; 31 officers and 175 men wounded. Ten men were missing. The Boers lost over 300 Burghers killed and wounded, besides several hundred horses. Their hospital with wounded prisoners was placed under the care of the British hospital, they having only one doctor, who, with his primitive staff, was quite unable to cope with the arduous work of attending the multitude of sufferers.

Numbers of the enemy of all nationalities—Germans, Hollanders, Irish, and others—were made

prisoners, and among them were General de Koch and Piet Joubert, nephew of General Joubert. General Viljoen was killed. The mongrel force, estimated at about 1200 strong, was commanded by Colonel Schiel, to whom it doubtless owed its excellent tactical disposition. This officer was wounded and taken prisoner. The *Times* gave somewhat interesting character sketches of prominent Boers who were killed or wounded on this occasion:—

"General Koch was Minute-Keeper to the Executive, and was President Kruger's most influential supporter. His son, Judge Koch, was appointed to a seat on the Bench, but was not popular, and was regarded as a puppet. The fighting Koch is not to be confounded with the General Koch, who belongs to Vryheid, and is a sterling warrior.

"Advocate Coster was State Attorney at the time of the Reform trials, but resigned owing to President Kruger having insulted him at a meeting of the Executive. He was an accomplished man, a member of the Inner Temple, and was very popular with the Dutch Bar.

"General Ben Viljoen was responsible for most of the fire-eating articles which appeared in the *Rand Post*."

"Colonel Schiel was court-martialled in past days for shooting four natives whom he accused of insubordination."

The courage of the Boers during this battle was immense. About two thousand were engaged, and these, though certainly aided by the strength of their position, fought valiantly, facing doggedly the heavy consummately well-directed fire of the British artillery, and returning it with undiminished coolness.

An interesting incident is mentioned in connection with the battle. When the fire of the British guns became overwhelming, eight plucky Boers dashed forward from cover, and, standing together, steadily opened fire on the men of the Imperial Light Horse, with the evident purpose of drawing their fire, while their comrades should change position. Out of this gallant little band, only one man was left to tell the tale!

[Pg 27]



THE BATTLE OF ELANDSLAAGTE— CHARGE OF THE 5th LANCERS.

Drawn by R. Caton Woodville.

The following is the casualty roll of officers killed at the battle of Elands-laagte:—

Imperial Light Horse.—Colonel Scott Chisholme,^[3] commander, killed; Major Wools Sampson, bullet wound, thigh, severely; Captain John Orr, bullet wound, neck, severely; Lieutenant William Curry, bullet wound, foot, severely; Lieutenant Arthur Shore, bullet wound, chest, severely; Lieutenant and Adjutant R. W. Barnes, wounded severely; Lieutenant Lachlan Forbes, wounded severely; Captain Mullins, wounded; Lieutenant Campbell, wounded; Lieutenant Normand, wounded. 21st Battery Field Artillery.—Captain H. M. Campbell, bullet wound, chest, severe; Lieutenant W. G. H. Manley, shell wound, head, severe. Staff.—Captain Ronald G. Brooke, 7th Hussars, bullet wounds, thigh and head, severe. 1st Battalion Devonshire Regiment.—Second Lieutenant H. R. Gunning, severely, bullet wound in chest; Second Lieutenant S. T. Hayley, severely, bullet wounds in hand and leg; Second Lieutenant G. F. Green, severely, bullet wound in forearm; Captain William B. Lafone, slightly, bullet wound. 1st Battalion Manchester Regiment.—Lieutenant-Colonel Arthur Curran, bullet wound, shoulder; Captain Charles Melvill, bullet wound, arm, severe; Captain William Newbigging, bullet wound, left shoulder, severe; Captain Donald Paton, bullet wound, thigh, severe; Lieutenant Cyril Danks, bullet wound, scalp, slight. 2nd Battalion Gordon Highlanders.—Killed: Major H. W. D. Denne, Lieutenant C. G. Monro, Second Lieutenant J. G. D. Murray, Lieutenant L. B. Bradbury. Wounded: Lieutenant-Colonel Dick-Cunyngham, bullet wound, arm, severe; Major Harry Wright, bullet wound, right foot, severe; Captain J. Haldane, bullet wound, leg, severe; Captain Arthur Buchanan, bullet wound, right side, severe; Lieutenant M. Meiklejohn, fractured humerus, severe; Lieutenant C. W. Findlay, bullet wound, arm and thigh, severe; Lieutenant J. B. Gillat (attached from Argyll and Sutherland Highlanders); Second Lieutenant I. A. Campbell, bullet wound, head and chest, dangerous; Lieutenant A. R. Hennessy (3rd Batt.), bullet wound, head and chest, severe.

The following tribute to the memory of Colonel Scott Chisholme is taken from Mr. John Stuart's correspondence to the *Morning Post*:—

"No death has been more severely felt than the Colonel's. He was a good man and a good soldier, brave to the point of recklessness, a wonderfully-inspiring leader, and, as I judged from about a month's knowledge of him, single-minded, fervent in all his work, passionately in earnest. His regiment almost worshipped him. On the day of the fight their keenness was increased because

[Pg 28]

he was keen, and they ignored the hardships they had gone through because he shared them and took them lightly, and did his best to improve matters.

"During the fight he only took cover once or twice, going from troop to troop, praising and encouraging the men in words that were always well chosen, for no man could phrase his blame or praise more aptly. At the last ridge he stopped to tie up the leg of a wounded trooper, and was shot himself in the leg. Two of his men went to his assistance, but he waved them off, telling them to go on with their fighting and to leave him alone. Then he was shot in one of the lungs, and the men went to his help, but while they were trying to get him to cover, a bullet lodged in his head and killed him. The last words he was heard to say were, 'My fellows are doing well.' His fellows will always remember that.

"I may be allowed to recall one or two interesting recollections of the Colonel. One is the speech he delivered when the Maritzburg Club dined him and his officers. Both he and General Symons spoke. Neither man was an orator, and yet each was more convincing than many orators, speaking simple, soldierly, purposeful words, words whose simplicity drove them home. Almost a week before the battle I saw the Colonel arranging his camp. He had taken off his tunic and helmet, and did twice as much direction as any other officer, and he worked as hard as any of the men. It was then, when I saw his vigour in full activity, that I realised his wonderful capacity for work—a capacity of which I had often heard, but which I had not been able to comprehend before.

"The last time I saw him was at the outspan before the battle began. He came to a group of us and gave one or two orders in such pleasant words that one knew that to obey him must in itself be a real delight. Then he sat down and gossiped with us, first about his luck in the morning, when a shell that hit the ground between his horse's feet had failed to burst, and afterwards about luck in general. He advised the officers to tell their men to sleep while they could, and then he said, 'Now I'll go and get half-an-hour's sleep myself.' But at that moment an aide-de-camp came saying that General French wanted to see him. When the Colonel returned, it was to order his regiment to saddle up and prepare to mount. In half-an-hour he was leading the attack on the first kopje.

"I like to think that before death smote him he knew that the battle was won, and that his fellows had done well, as he expected that they would, as he had helped them to do by example and generous encouragement."

[Pg 29]

A private of the Gordon Highlanders, in a letter dated Ladysmith, November 2, gave a vivid account of the charge of the Gordons at Elandslaagte, and described how Lieutenant-Colonel Dick-Cunyngham was wounded when leading his men, and that officer's chagrin at his being rendered impotent. He said: "We charged three times with the bayonet, and my gun was covered with whiskers and blood, though I don't remember striking anybody, but I was nearly mad with excitement, shells bursting and bullets whizzing round like hail. I was close behind the commanding officer when he was wounded. He was shot and had to sit down, but he cheered on his men. 'Forward, Gordons,' he cried, 'the world is looking at you. Brave lads, give it to the beggars, exterminate the vermin—charge.' He then started crying because he could no longer lead his battalion, and he would not retire from the field until the day was won. He is a fine man to lead a battalion—as brave as a lion. The Gordons were the last line, and we raced through the Manchesters and the Devons and the Light Horse Volunteers, all charging together."

Here we have a proof how much the morale of soldiers may be influenced by their immediate chief.

The *Natal Advertiser* in its account of the final scene said:—

"By a quarter past six the Devonshire Regiment, the Gordon Highlanders, and the Manchester Regiment, with the Imperial Light Horse, were in a position to storm the Boer camp from the enemy's front and left flank, and the signal for the bayonet charge was sounded. Then was witnessed one of the most splendid pieces of storming imaginable, the Devons taking the lead, closely followed by the Gordons, the Manchesters, and the Light Horse, in the face of a tremendous, killing fire, the rattle and roar of which betokened frightful carnage.... A bugler boy of the 5th Lancers shot three Boers with his revolver. He was afterwards carried round the camp amid cheers."

So many acts of gallantry were performed that they cannot all be related. It is impossible, however, to allow the wondrous pluck of Sergeant Kenneth M'Leod to go unrecorded. During the charge this gallant Scot was twice struck, once in the arm and once in the side. He however continued to pipe and advance with the Gordons to their final rush. Presently came more bullets, smashing his drones, his chanter, and his windbag, whereupon the splendid fellow had to give in.

Perhaps the most heart-rending period was that following the last gleam of daylight, when the Medical Staff went forth to do their melancholy duty. All were armed with lanterns, which, shining like pale glow-worms, made the dense gloom around more impenetrable still. Yet, groping and shivering through the black horror of the night, they patiently pursued their ghastly task with zeal that was truly magnificent. Dead, dying, wounded, were dotted all over the veldt. There, bearded old Boers, boys, Britons in their prime, were indiscriminately counted, collected, tended, the Field Hospital men and Indian stretcher-bearers working incessantly and ungrudgingly till dawn. Gruesome and heart-rending were the sights and scenes around the camp-fires when such wounded as could crawl dragged themselves towards their comrades.

[Pg 30]

Pitiable the faces of the survivors as news came in of gallant hearts that had ceased to beat. A pathetic incident was witnessed in the grey gloom of the small hours. One of the bearers chanced on an ancient hoary-headed Boer, who was lying behind a rock supporting himself on his elbows. The bearer approached warily, as many of the enemy were known to have turned on those who went to their succour. This man, however, was too weak from loss of blood to attempt to raise his rifle. Between his dying gasps he begged a favour—would some one find his son, a boy of thirteen, who had been fighting by his side when he fell. The request was obeyed. The little lad, stone-dead, was discovered. He was placed in the failing arms of his father. The unhappy old fellow clasped the clay-cold form, and hugged it despairingly to himself, and then, merciful Providence pitied him in his misery—his stricken spirit went out to join his son.

An officer who was wounded, and who spent the night in the terrible scene, thus described his own awful experiences: "I lay where I fell for about three-quarters of an hour, when a doctor came and put a field-dressing on my wound, gave me some brandy, put my helmet under my head as a pillow, covered me with a Boer blanket which he had taken from a dead man, and then went to look after some other poor beggar. I shall never forget the horrors of that night as long as I live. In addition to the agony which my wound gave me, I had two sharp stones running into my back; I was soaked to the skin and bitterly cold, but had an awful thirst; the torrents of rain never stopped. On one side of me was a Gordon Highlander in raving delirium, and on the other a Boer who had his leg shattered by a shell, and who gave vent to the most heart-rending cries and groans. War is a funny game, and no one can realise what its grim horrors are till they see it in all its barbarous reality. I lay out in the rain the whole of the night, and at daybreak was put into a doolie by a doctor, and some natives carried me down to the station. The ground was awfully rough, and they dropped me twice; I fainted both times. I was sent down to Ladysmith in the hospital train; from the station I was conveyed to the chapel (officers' hospital) in a bullock-cart, the jolting of which made me faint again. I was the last officer taken in. I was then put to bed, and my wound was dressed just seventeen hours after I was hit. They then gave me some beef-tea, which was the first food I had had for twenty-seven hours."

[Pg 31]

The amazing spirit of chivalry that animated all classes, general officers, medical officers, chaplains, and even stretcher-bearers, in this campaign has been the subject of much comment. It was thought that modernity had rendered effete some of the sons of Great Britain, and the war, if it should have done no other good, has served to prove that times may have changed, but not the tough and dauntless character of the men who have made the Empire what it is.

The following, from a Congregational minister of Durban, who had volunteered to go to the front as honorary chaplain to the Natal Mounted Rifles, in which corps many of his congregation enrolled, is of immense interest. It gives us an insight into the inner core of valour—the valour of those who, unarmed, share the dangers without the intoxications of the fight. It runs:—

"The Lancers, who were mistaken by the Boers in the growing darkness for a body of their own men, fell upon them and turned a rout into a wild flight. Commander Schiel was very furious at losing the battle, and said he would like to kill every man, woman, and child in Natal. In this he was the exception to the rule, for the captives whom we liberated said the Boers had treated them with great kindness. After the battle Dr. Bonnybrook and I spent the night on the field of battle, and also followed the retreating Boers for a distance of six or seven miles, searching for and tending the wounded and dying. In the early hours of the morning we came to a Boer field-hospital, and shouting out, 'Doctor and Predicant,' we entered and rested, and slept there awhile. By daybreak we were out again. About six miles from camp Dr. Bonnybrook rode up to twenty-five mounted and armed Boers, and told them they were his prisoners. Ordering two to take the weapons of their comrades, he marched them into camp prisoners. For an unarmed man to accomplish alone, this was an exceedingly brave thing to do. After the battle one of the captured held up his gun and said, 'Look through this. I have not fired a shot. I am a Britisher. They forced me to come.'"

Among other heroes of Elandslaagte was Lieutenant Meiklejohn of the Gordon Highlanders. This young officer, one of the "Dargai boys," helped the charge in an endeavour to embarrass the Boer flank. Supported by a party of Gordons, so runs the narrative, Meiklejohn waved his sword and cried out to his party hastily gathered round him. But the Boer ranks were alert, and poured in a deadly fire on the gallant band. Lieutenant Meiklejohn received three bullets through his upper right arm, one through the right forearm, a finger blown away, a bullet through the left thigh, two bullets through the helmet, a "snick" in the neck, while his sword and scabbard were literally shot to pieces. He has by now lost his right arm, but, happily, being left-handed, it is hoped he may remain in the profession he is so well calculated to adorn.

[Pg 32]

A private soldier in the 2nd Battalion Gordon Highlanders recounted an extraordinary personal experience. He said:—

"We, the Devons, Imperial Light Horse, and others, had a fight at Elandslaagte with the Boers, and I never enjoyed myself so much before. You first have to get christened to fire, and then you think nothing of the shells bursting about you, and the bullets which go whistling past like bees. We went forward by fifty-yard rushes, and at every rush you could hear a groan, and down would go one of our comrades, either killed or wounded, poor chap. When we were miles from the enemy they opened fire on us with shell, and as we were going along in mass, one of the shells burst on the left of the company, and one of our men of my section—Bobby Hall—got shot dead with a piece of the shell going straight through his head. That was what made more than one wish to turn and run. But what would Britain do if her soldiers ran from the enemy? At last we got to where we could get a shot at the Boers with our rifles, and you may bet we gave them more than one, as perhaps the papers have told you. I got through the rifle-fire down to the bayonet charge on the hillside, when I felt a sting in the left arm, and looking down, found I was shot in the wrist. In changing my position I got shot in the centre of the forehead. The bullet did not go straight through. It glanced off my nose-bone, and came

out above my right temple.... On looking round, I was just in time to see the blood squirt from the first wound. I shifted my position in quick time, for I did not want another from the same rifle. I lay still after doing this for a while, when the thought came to me to get my wrist bandaged and try to shoot again. On changing my position I got a bullet right in the 'napper.' I was out of action then, for all was dark. I heard the officer I was going to get the bandages from say, 'Poor chap! he's gone.' But no, I am still kicking."

THE RETREAT FROM DUNDEE

Owing to the Boers having posted their 15-centimetre gun on the Impati for the purpose of shelling the camp and town, the troops and inhabitants removed to a position some three miles south of Dundee village. The movement was fraught with many discomforts. Rain fell in torrents, making the roads a mass of slush and enveloping everything in a thick mist, while provisions, which had been hastily gathered together, were scarce. On the following day, Sunday, an attempt was made to return to camp, but the Boer firing continued so active that the project had to be abandoned. Thereupon, on Sunday night the whole column, having first loaded four days' supplies from their old camp and set there lighted candles sufficient to cause such an illumination as would suggest to the Boers an idea of occupation, quietly stole away. No one exactly knew their destination. At nine of the clock the Army Service Corps waggons moved to the camp, were loaded, and by midnight commenced rumbling along in the damp obscurity. The advance column, after passing through Dundee, where it was joined by transport and rearguard, proceeded along the Helpmakaar road on the way to Ladysmith.

[Pg 33]



**MAJOR-GENERAL SIR W. PENN
SYMONS, K.C.B.**

Photo by R. Stanley & Co., London.

On Monday afternoon the first halt was called, but the rest was of short duration, for at ten the column was again plodding along through the miry roads in hourly dread lest the whole scheme should be spoilt, and the Boers suddenly arrest the course of the two-mile-long column.

And they had indeed good reason for alarm. They were forced to plod through a narrow pass in the Biggarsberg range of mountains, so narrow indeed that a hundred Boers might have effectually barred their way. Here, through this perilous black cylinder of the hills, they marched at dead of night. It took them between the hours of half-past eleven till three, stumbling and squelching in the mire, and knowing that should the enemy appear, should they but shoot one of the oxen of the leading waggon of the convoy, and thus block the cramped defile, all chance of getting safely through to Ladysmith would be at an end. This was by no means a happy reflection to fill men's minds in the dripping, almost palpable, darkness of the night, and the resolute spirit of the gallant fellows who uncomplainingly stowed away all personal wretchedness and stuck manfully to their grim duty is for ever to be marvelled at and admired. Fortunately the Dutchmen, "slim" as they were, had not counted on the possibility of this march being executed at all, still less of its being executed in pitch darkness. They were caught napping, and the party, who had left kit, provisions (except for the four days), and everything behind them, who were now drenched to the skin in the only clothes they possessed, at last reached Sunday River in safety.

Here they eagerly awaited an escort of the 5th Lancers, which had been detached by Sir George

White from Ladysmith to meet them. These, to the great joy of the worn-out travellers, appeared on Wednesday afternoon. On that evening the column again started off for a last long wearisome tramp, the men, who had not been out of their clothes for a week, being now ready to drop from sleeplessness and exhaustion. But valiantly they held on. Not a word, not a grumble. All had confidence in General Yule and his officers, who shared with the men every hardship and every fatigue; each realised his individual duty to make the very best of a very bad job, and pluckily kept heart till the last moment. Torrents of rain fell, making the night into one vast immensity of slough and pool, but the stumbling, straining left, right, left, right, of the retreating men continued ceaselessly through the weary hours. On Thursday morning, the 26th, to their intense relief, they found themselves at last in the long-looked-for camp at Ladysmith.

The excitement of arrival was almost too much for the exhausted, fainting troops, but the cheers that went up from a thousand throats brought light to their sleep-starved eyes and warmth to their chilled frames. There was rest at last—rest and safety, food and warm covering, though of a more practical than artistic kind. The Devons—who had just come grandly through the fight at Elandslaagte and looted the Boer camp of innumerable saleable odds and ends—out of their newly-gained wealth "stood treat." In the joy of their hearts each of the men subscribed sixpence, and the gallant Dublin Fusiliers, the heroes of Glencoe, who, all unwashed and unshorn, now looked like chimney-sweeps rather than the warriors they were, were invited to a fine "square meal." It is difficult to imagine the condition of those battered braves after their week of hardship, fighting, and privation, and sticklers for etiquette would have been shocked at the manners and customs enforced by warlike conditions. One who dined with the Dundee column gave the following graphic description of the luxurious repast:—

[Pg 34]

"To begin with, there was no sort of furniture either in the messroom or the anteroom. If you wanted to sit down, you did so on the floor. We each got hold of a large tin mug, and dipped it into a large tin saucepan of soup and drank it, spoons not existing. A large lump of salt was passed round, and every one broke off a piece with his fingers. Next you clawed hold of a piece of bread and a chunk of tongue, and gnawed first one and then the other—knives and forks there were none. This finished the dinner. Add to this two or three tallow-candles stuck on a cocoa tin, and the fact that none of the officers had shaved, or had had their clothes off for a week, and had walked some forty-five miles through rivers and mud, and you will have some idea of how the officers' mess of one of the smartest of Her Majesty's foot regiments do for themselves in time of war. Not a murmur or complaint was to be heard."

Their state must certainly have been pitiable, for it will be remembered that on the retirement from Dundee rations for four days only were loaded, and provisions for two months, besides all officers' and men's kit and hospital equipment, were left behind.

And, sad to say, so also were the wounded. It was necessary for their future well-being to desert them. The men who had so gloriously led to victory now found themselves stranded and in a strange position—the vanquishers at the mercy of the vanquished! Most melancholy of all must have been the plight of those unhappy sufferers when they first learnt that their comrades were marching farther and farther away, and that they, in all their helplessness, must be left lonely—unloved, and perhaps untended—in charge of the enemy. One dares not think of the agonies of those sad souls—the nation's invalids—bereft of kindly words and kindred smiles; one cannot linger without a sense of emasculating weakness on the sad side-picture of battle that, in its dumb wretchedness, seems so much more paralysing than the active horror of facing shot and shell in company with glorious comrades in arms. Let us hope there was some one to whisper to them, to persuade them that all was for the best; that the safety of their sick selves and their sound mates depended on this retreat, this wondrous retreat which, when the tale of the war in its entirety shall be told, will shine like a dazzling light among records whose brilliancy in the history of British achievements cannot be excelled. Perhaps, too, they had faith to inspire them with the certainty that all that they had suffered in that dark hour for their country and for the weal of their fellows, would be remembered to their glory in the good times to come.

[Pg 35]

While the retreat was going forward Glencoe's gallant hero was breathing his last. After hopelessly lingering for three days, General Sir W. Penn Symons passed away. He expired in the hands of the enemy at Dundee hospital on Monday the 23rd of October. The next day he was quietly buried with profound signs of mourning.

SIR W. PENN SYMONS—GLENCOE

By the death of Major-General Sir William Penn Symons, the British army lost a brilliant and distinguished soldier, and a man of great valour and courage. He came of a Cornish family, the founder of which was a Norman knight who came over with William the Conqueror. The eldest son of the late William Symons, Recorder of Saltash, he was born in 1843, and in 1863 joined the South Wales Borderers—the old 24th Regiment. He became lieutenant in 1866, captain in 1878, major in 1881, lieutenant-colonel in 1886, and colonel in 1887.

His first experience of active service was in 1877, when the Borderers took the field against the Galekas. In the Zulu War of 1879 he served with distinction, but was not present at the battle of Isandlwana, being away from his regiment on special duty. In 1885 he served as Deputy-Assistant-Adjutant and Quarter-Master-General, organising and commanding the Mounted Infantry in the Burmese Expedition. Being honourably mentioned in dispatches for his services with the Chin Field Force, he received a brevet-colonelcy. In 1889-90 he was given a brigade in

the Chin-Lusha Expedition, was again mentioned in despatches, made a C.B., and received the thanks of the Government of India. He commanded a brigade of the Waziristan Field Force in 1894-95 with like distinction, but he will best be remembered in connection with the campaign on the North-West Frontier of India in 1897-98, after which he was made a K.C.B. In 1898 he gave up his appointment in India and took command of the British troops in Natal.

[Pg 36]

He was one of the best shots in the army, his military hobby in fact being musketry, though he was also a great authority on the subject of mounted infantry. He was a keen sportsman, an excellent linguist. He was highly respected by all who knew him. As an evidence of how he was regarded by his brother officers, one may quote from the telegram which was sent from Sir G. White to the War Office on the morrow of the battle of Glencoe. The communication said: "The important success is due to his great courage, fine generalship, and gallant example, and the confidence he gave to the troops under him."

Mr. Winston Spencer Churchill's remarks about him, in a letter to the *Morning Post*, show how fully he was appreciated for his social as well as for his military qualities.

"So Sir Penn Symons is killed! Well, no one would have laid down his life more gladly in such a cause. Twenty years ago the merest chance saved him from the massacre at Isandhlwana, and Death promoted him in an afternoon from subaltern to senior captain. Thenceforward his rise was rapid. He commanded the First Division of the Tirah Expeditionary Force among the mountains with prudent skill. His brigades had no misfortunes; his rearguards came safely into camp. In the spring of 1898, when the army lay around Fort Jumrood, looking forward to a fresh campaign, I used often to meet him. Every one talked of Symons, of his energy, of his jokes, of his enthusiasm. It was Symons who had built a racecourse on the stony plain; who had organised the Jumrood Spring Meeting; who won the principal event himself, to the delight of the private soldiers, with whom he was intensely popular; who, moreover, was to be first and foremost if the war with the tribes broke out again; and who was entrusted with much of the negotiations with their *jirgas*. Dinner with Symons in the mud tower of Jumrood Fort was an experience. The memory of many tales of sport and war remains. At the end the General would drink the old Peninsular toasts: 'Our Men,' 'Our Women,' 'Our Religions,' 'Our Swords,' 'Ourselves,' 'Sweethearts and Wives,' and 'Absent Friends'—one for every night in the week. The night I dined it was 'Our Men.' May the State in her necessities find others like him!"

THE BATTLE OF REITFONTEIN

On the morning of the 23rd, thirty men of the 18th Hussars rode into camp at Ladysmith, after having had some exciting adventures. The facts were these. On the arrival at Glencoe camp of the news of the Boer defeat at Elandslaagte, General Yule had detached a force to cut off the flying Boers. Unfortunately, the Hussars who were sent out for this purpose were themselves cut off, but at last, with the enemy at their heels, succeeded in fighting their way down a dangerous pass, and eventually effecting their escape. This, too, without the loss of a man!

[Pg 37]

To return to the great retreat. While General Yule was falling back to effect a junction with General White, the latter officer conceived a brilliant plan to ensure the safety of the returning force. He was aware that Yule's column was marching *via* the Helpmakaar road, Beith, and the Waschbank and Sunday River Valleys, and therefore, to cover the movement, he sent out a strong force to the west of the road. The force consisted of the 21st, 42nd, and 53rd Field Batteries, 1st Devons, 1st Liverpools, 1st Gloucesters, 2nd King's Royal Rifles (just arrived from Maritzburg), 19th Hussars, 5th Lancers, Natal Carabiniers, Border Mounted Rifles, and Imperial Light Horse.

The enemy was already strongly posted on the kopjes a mile and a half west of the railway and two miles south-east of Modder Spruit station, in all, some seven miles from Ladysmith. It was necessary, therefore, to keep him well occupied, and divert his attention from the Dundee column. On both sides firing soon commenced, but our guns were promptly silenced. Then the British took up a position three-quarters of a mile west of the railway, and for some twenty minutes kept up a heavy artillery fire supplemented by sharp volleys from the infantry. Before long the kopjes were cleared and the object of the British attack accomplished. The main body of the Boers retired in the direction of Besters, a point to the south of Ladysmith, where, in the circumstances, it was more advisable for them to be. In this battle a great deal of sharpshooting, especially at officers, took place on the part of the foe, who also resorted to their old tactics of discharging their guns and running away, again discharging them and again running—a trick they had been mightily fond of in their dealings with the Zulus, and which was calculated to tire out the fleetest antagonists. Colonel Wilford of the 1st Gloucester Regiment was mortally wounded. Sir George White had a narrow escape, as the Boers turned their artillery on the Staff, and their first shell came screaming within fifteen yards of the General. Captain Douglas, 42nd Battery, had also a marvellous escape, his horse having been wounded and his haversack ripped open by a splinter. In this smart engagement, as Sir George White in his official statement declared, "Our side confined its efforts to occupying the enemy and hitting him hard enough to prevent his taking action against General Yule's column." The manœuvre, as we know, was eminently successful, but was not executed without cost to those who assisted in it. The following was the official list of the officers killed and wounded:—

[Pg 38]

1st Battalion Gloucestershire Regiment.—Killed: Lieutenant-Colonel and Colonel Edmund Percival Wilford. 42nd Battery Field Artillery.—Wounded: Lieutenant S. W. Douglas, shell-graze of abdomen, slight. 53rd Battery Field Artillery.—Major Anthony J. Abdy, shell-graze of right knee, slight;

Lieutenant Arthur Montague Perreau, bullet wound, right leg, severe; Lieutenant George Herbert Stobart (from 34th Battery), bullet wound, finger, slight. 19th Hussars.—2nd Lieutenant A. Holford, bullet wound, slight. 1st Battalion Gloucestershire Regiment.—Lieutenant Carlos Joseph Hickie, slightly.

The Boers, triumphant, entered Dundee about the same time as General Yule and his worn-out troops were being enthusiastically greeted in Ladysmith. They attacked the Dundee Town Guard, putting it to flight, and turned many civilians out of their houses. Later, they mounted two big guns at Intintanyone, some 4500 yards from the Ladysmith camp, and their energies pointed to further activities.

LADYSMITH

Here it may be as well to review the geographical position of this now famous place. Ladysmith, as a position for purposes of defence, is very badly situated. It lies in the cup of the hills, and stony eminences command it almost in a circle. Towards the north is Pepworth's Ridge, a flat-headed hill fringed at the base with mimosa bushes. North-east is Lombard's Kop, which is flanked by a family of smaller kopjes. South of this hill and east of Ladysmith is a table-headed hill called Umbulwana. South of this eminence runs the railway through the smaller stations of Nelthorpe and Pieters towards Colenso. To the west of Pepworth's Ridge is Surprise Hill, and other irregular hills which rise from four to five hundred feet on all sides. The place is watered by the Klip River, which enters the valley between the hills on the west, twists gracefully in front of the town, and turns away among the eastern hills before making its way to the south. The position, commanded as it was on every hand, was not an enviable one, but the glorious fellows who had fought in two brilliant engagements were in no wise disconcerted.



**OFFICER OF THE NINTH
LANCERS.**

Photo by Gregory & Co., London.

Yet all were on the alert, for the Boers had now closed in round the town, and an engagement was hourly expected. A little desultory fighting took place, but when the British troops advanced, those of the Orange Free State at once retired towards the border. The town, however, was somewhat harassed for want of water, owing to the Boers having cut off the main pipes. The inconvenience was merely temporary, as the Klip River, which runs through the main position, was fairly pure, and there were wells which could be made serviceable. A captive balloon was inflated by the Royal Engineers, and was used for the purpose of making observations, much to the annoyance of the Dutchmen, who had securely perched themselves at points of vantage on the surrounding hills. They were at this time on the north and east, having laagered south-east of Modder Spruit and Vlaak Plaats, some seven miles from Ladysmith, and were preparing to arrange a closely-linked chain of earthworks that should effectually surround the garrison. An exchange of shots now and then, however, was all that took place for a while between the contending parties, though both sides were evidently gathering themselves together for some definite move. The situation was thus described by a captive in Ladysmith:—

"Saturday and Sunday have passed without any demonstration being made by the enemy. The camp has again assumed its condition of readiness and watchfulness. On Saturday afternoon it was rumoured that General Joubert, with the commando encamped at Sunday River, was experiencing difficulty in transporting the 40-pounders across the spruit, which was swollen after the heavy rains. Small parties of Boers are constantly on the alert, and are harassing the British outposts.

"Scarcely a day passes without the outlying pickets being fired upon. The latest reports say that the enemy are gathered in considerable force on Dewdrop Farm.

"Great excitement has been caused in the Artillery camp by the capture of a supposed spy, who was caught in the act of tampering with the guns. The man had eluded the vigilance of the sentry, and had opened the breech of one of the 15-pounders when he was noticed. He was promptly arrested. When asked what he was doing, he said he was a lieutenant in the 18th Battery. Questioned further, he contradicted himself, and said that it was quite by accident that he opened the breech. He admitted that he belonged to Johannesburg. He was marched off in custody of the guard. The sequel of the story has not been made public.

"No camp followers are allowed, and all here have been ordered to leave. The enemy are now undoubtedly closing round Ladysmith. A large commando is reported to be on the Helpmakaar road, and a large camp has been formed between the Harrismith Railway Bridge and Potgieter's Farm. The camp on Dewdrop Farm extends for four miles. The enemy have an exceptional number of waggons. The Boer patrols are very venturesome; they have approached within three and a half miles of the town, and one party actually removed carcasses ready dressed for consumption from within the slaughtering lines."

[Pg 40]

The prospect was far from cheering, particularly as Sir George White was well aware that his field-guns were ineffective against the powerful guns of position which the enemy were handling with unpleasant dexterity. At this critical period the united forces of Ladysmith and Glencoe only amounted to some 10,000 men, more than half of whom were infantry. The General, however, put the best face he could on the matter, telegraphed home for big guns—and waited!

General Joubert now expressed his opinions on the causes of the war. His ideas, published in the German journals, were of interest as showing the sentiments of the opposite camp:—

"It was evident to our Government after the Jameson raid, that Great Britain would be forced in time by various sordid elements into a war of extermination with the Boers. It was equally clear that this danger could only be averted by armaments on a most extensive scale. We were conscious that the impending war of annihilation would incur the sharpest condemnation on the part of the other European Powers, but history had taught us that not one of these Powers would be roused to intervene in our favour. In these circumstances we had to rely on our own strength.

"By indefatigable zeal and heavy sacrifices to augment our forces, and yet to secrete them from the observation of the British—these were the objects of our noblest exertion. Well, we succeeded, and hoodwinked the British. Spies were permitted to obtain glimpses of our obsolete artillery, but until the war was on the point of breaking out they had no suspicion of the formidable extent of our stores of modern material.

"We counted on the unreliability of the British announcements concerning their own preparedness, and attended as little to their cries of 'To Pretoria!' as did the Germans in 1870 to the Parisian boasters who shouted 'À Berlin!' Without completely denuding her colonies of troops, Great Britain cannot possibly despatch more than about 85,000 men to South Africa. Of this imposing force, only half will be available for the chief battles. It may be possible for Great Britain to effect the landing in various places of these troops by the middle of December. I estimate, however, that the losses in prisoners, killed, sick, and wounded will amount in the meantime to some 10,000. There will thus remain 75,000 men.

"Even should we fail to prevent the junction of the British troops under Sir Redvers Buller and be compelled to retreat, the British army would become from natural causes so debilitated that it would represent a force for operative purposes not exceeding 35,000. The remainder would have to be employed in protecting lines of communication extending some 700 miles.

"Our lines of depôts, on the contrary, are in home territory. They are constructed at regular distances in three directions, and barely 500 men are necessary to cover them. Excellently-organised communications have been established between them, and if any one of them be seriously threatened, the stores—if rescue be impossible—will be destroyed.

"Moreover, defensive warfare—to which we need not think, however, of resorting for a long time to come—is fraught with far greater advantages to us than offensive operations. With a change of *terrain* there will be a change of tactics. In Natal and the south we have to deal with unfamiliar conditions. On the high plains of the Transvaal and the Orange Free State we shall be at home, and the British will meet opposition from us and from Nature at every step of the way, and at all times be prepared for action on two or three fronts. In this way will be developed a guerilla warfare of a most inconceivably bloody character, such as the British will be unable to endure for more than a few months."

[Pg 41]

General Joubert then protested that the Boers were fighting merely for the freedom of their own "narrower" Fatherland, and not with a view to the destruction of British preponderancy in South Africa. He acknowledged the bravery of the British soldiers, but imagined that hardships and deprivations would so demoralise them that they would be unable to hold out against an enemy superior in numbers.

"In these circumstances," he continued, "do not accuse me of boasting when I frankly say that victory will be ours. Every one of us is filled with the same conviction and unshakeable faith in God, that He will remain as true to us in this as in former wars, and that He will not allow the blood shed and to be shed in this struggle, that will probably last yet a year, to extinguish us and our children."

Towards the end of October Sir George White decided that something must be done to protect his line of communication with the south. The Boers were spreading out in crescent form and drawing gradually nearer to the town. On the north were troops commanded by General Joubert. On the west was a Free State commando, and on the east was General Lucas Meyer, who owed us a grudge after the events of Talana Hill. Reinforced by troops from General Erasmus, he now desired to press towards the railway with a view to seizing it at some point south of the town. It was necessary at all costs to put a stop to this scheme. Colonel Ian Hamilton with an Infantry Brigade was therefore despatched on the 27th to Lombard's Kop, a hill some five miles east of Ladysmith. There he bivouacked for the night, with a view to clearing the enemy out at the point of the bayonet on the morrow. He never brought his plan into execution, however, for Sir George White, having been informed of the size of Meyer's force, ordered him to fall back on the town. On Sunday the 29th it was discovered that the Boers were intrenched in lines that extended over twenty miles, while "Long Tom," their six-inch gun, was perched on Pepworth Hill, its big ominous muzzle being situated some 7500 yards to the north of Ladysmith. In addition to this formidable weapon, field-guns with a range of some 8000 yards were posted about in well-concealed positions. For the protection of our line of communication it was necessary that the enemy, though three times as strong as the British force, should be dispersed, and that night, at half-past ten o'clock, Colonel Hamilton again set out with three battalions, the Devons, the Gordons, the Manchesters, and a Brigade Division of Artillery. The night was dark but clear, and the troops marched along the Newcastle Road to Limit Hill, a strong kopje some three miles north of Ladysmith, and half-way between that town and Pepworth Hill. There they bivouacked for the night. While this party was moving as described, a small force under Colonel Carleton, composed of four and a half companies of the Gloucestershire Regiment and six companies of the Royal Irish Fusiliers and No. 10 Mountain Battery, was moving towards Nicholson's Nek with a view of seizing it. But of Colonel Carleton's column anon.

[Pg 42]

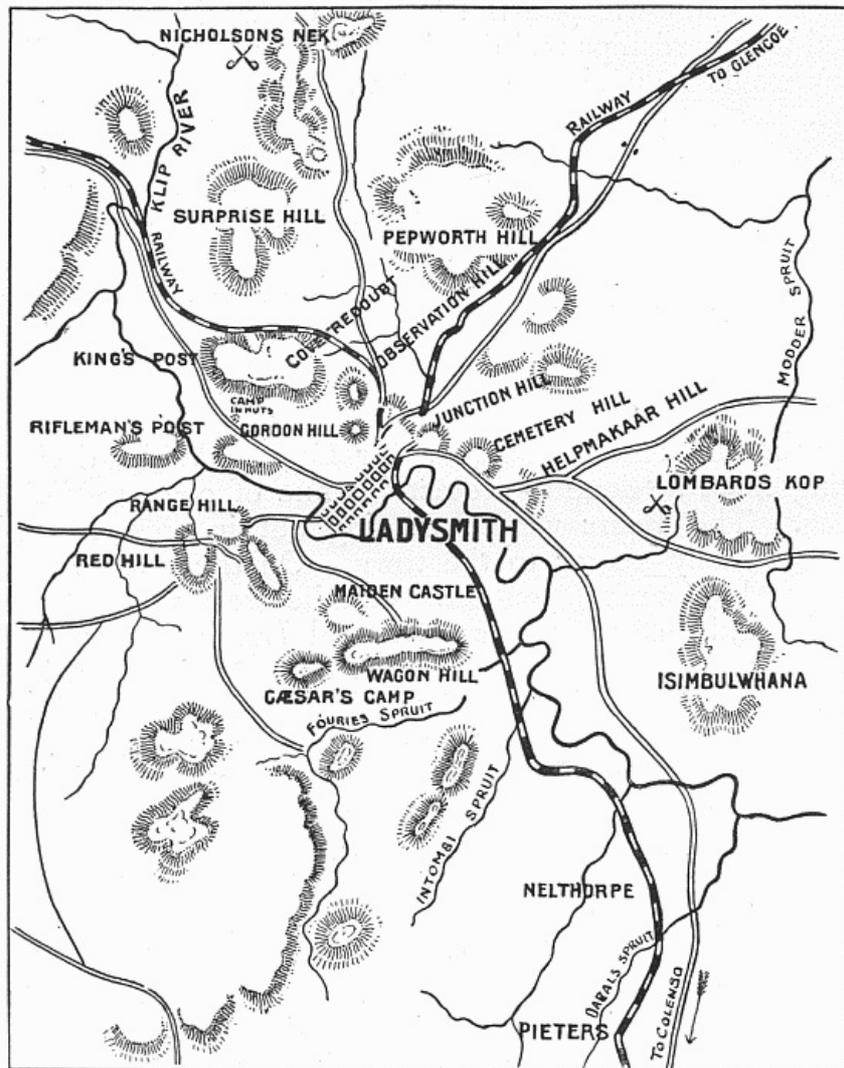

MAP OF LADYSMITH AND SURROUNDING HEIGHTS

On Colonel Ian Hamilton's right flank, towards Lombard's Kop, was Colonel Grimwood, with the 1st and 2nd King's Royal Rifles, the Liverpools, Leicesters, and Dublin Fusiliers, three Field-Batteries, and the Natal Volunteer Artillery. On the extreme right, when day broke, was General French with a Cavalry Brigade and some volunteers. The idea was, that while Colonel Grimwood was shelling the Boer position to the north of Lombard's Kop, General French should prevent any attempt to turn his right; the enemy's artillery silenced, Colonel Grimwood was to drive him along the ridge running to Pepworth, and, under cover of the British guns, press the Boers towards their centre. Meanwhile our centre, under Colonel Hamilton, was to attack a hill where the enemy was in force, rout him and join in the general scheme, while Colonel Carleton protected the centre from a flank movement. Unfortunately "the best laid schemes o' mice and

[Pg 43]

men gang aft agley," and General White's admirable scheme failed, as we shall learn. An artillery duel began operations, and this continued for two long hours, while the warm spring morning developed, and the Boers, who had been warned of our plans and had changed their position during the night, were laughing in their sleeves at the capital surprise they had prepared. They had drawn off their men from the point that was to have been the objective of our centre, and extending and reinforcing their left, were calmly waiting our attack. The artillery duel continued till seven o'clock, our batteries with great difficulty searching out the enemy's position. Colonel Grimwood, with two battalions of the King's Royal Rifles, held the kopjes and ridges in front of Farquhar's Farm, while mounted infantry and troopers of the 18th Hussars, supported by the Liverpools and Leicesters, were posted on the hills on the right. Behind them came the artillery, who directed their fire at the hill above the farm, where the enemy was supposed to be intrenched.



**BEFORE LADYSMITH—HORSE ARTILLERY
GALLOPING TO TAKE UP A NEW
POSITION.**

Drawn by R. Caton Woodville.

The Boers, who in great hordes had streamed from the hills like a mountain torrent and concealed themselves in the surrounding ridges, now made all Colonel Grimwood's plans impossible. He seemed, indeed, in danger of being annihilated by sheer force of superior numbers, when troops from the centre were pushed forward to his support. A smart engagement ensued, the Boers making energetic efforts to penetrate the line between the Infantry and Artillery, while the 53rd Battery changed front to meet the attack and the 5th Lancers struggled to form up on the left of the rifle regiments. But the enemy's automatic quick-firing gun vomited forth its death-dealing steel with such persistence that the cavalry was forced to retire at a gallop. The gunners again came to the rescue, and six field-batteries, spread over in a semicircular front of three-quarters of a mile, sent their shrapnel over the heads of the infantry to crash on the ridges occupied by the Boers.

At this critical moment, when the turmoil of warfare was at its hottest, and when our gallant troops were struggling unsuccessfully to hold their own against an overwhelming number of the enemy, a message came from Sir George White to retire. Some sort of a panic had taken place in the town, owing partly to the fact that the Boers were threatening it from another quarter, partly to the persistent shelling of "Long Tom," which, as some one described, was like a voluble virago, determined to have the last word! All efforts to silence the horrible weapon had failed, and for some three or four hours it had sent its eighty-four-pound shells shrieking into the town. There was no resource but to fall back, which was done to the appalling detonations of the Boer guns all going at once, while "Long Tom," like some prominent solo-singer, dominated the whole clamouring orchestra. To silence him and to cover the retreat, a Lieutenant of the *Powerful*, in charge of a gun drawn by a team of oxen, went out on the road between Limit Hill and Ladysmith. Before the gun could be got in position, however, "Long Tom" had spotted it—barked at it—overturned it, and killed several of the oxen. But his triumph was short-lived. Another rival performer had come on the scene, namely, the twelve-and-a-half-pounder of the Naval Brigade. It came, saw, and conquered, knocking out "Long Tom" at the fourth shot!

[Pg 44]

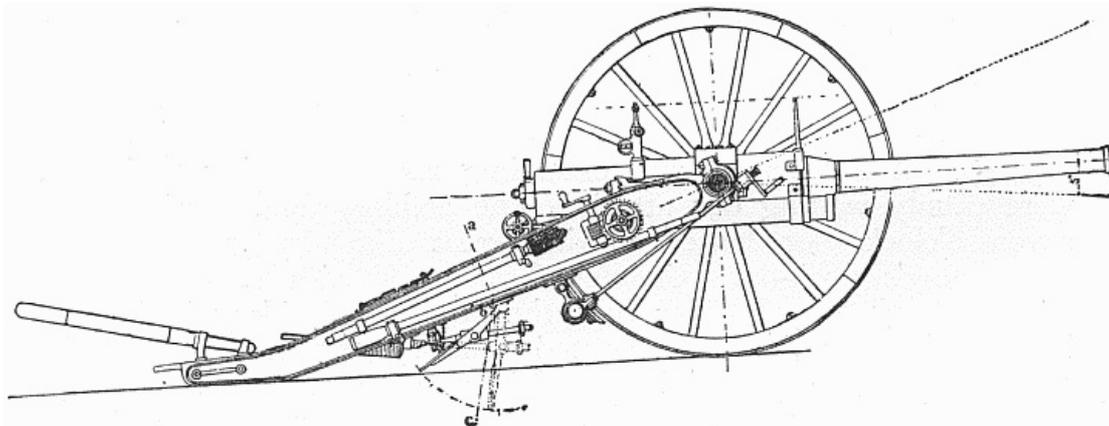

TYPES OF ARMS—THE CREUSOT QUICK-FIRING FIELD GUN, OR "LONG TOM"

The whole action of the Naval Brigade reads like a fairy story. Ladysmith on the point of exhaustion, with all its troops engaged and no big guns wherewith to meet the terrific assaults of the six-inch cannon on Pepworth Hill, was almost in despair. At the eleventh hour up came the Naval Brigade under Captain the Hon. Hedworth Lambton of H.M.S. *Powerful* with 280 Bluejackets, two 4.7 guns, and four twelve-and-a-half-pounders. Then the affair was done. It was just one, two, three, and away—for the fourth splendidly-directed shot saved the situation.

[Pg 45]

In this engagement great feats of daring were accomplished, feats which have now become so general that we have almost ceased to gasp in wonder at the heroism of the "mere man" of the nineteenth century. When the regiments were forced to retire from the death-laden region of Lombard's Kop, Major Abdy of the 53rd Battery R.A., dashing across the plain under a storm of shells from a quick-firing gun, brought his battery between the enemy and the straggling mass of retreating soldiers. Horse and man rolled over, but the fire of the 53rd never slackened till the imminence of danger was past. The correspondent of the *Standard*, who was present, said: "When the moment came for the battery to fall back, the limber of one of the guns had been smashed and five horses in one team had been killed. Captain Thwaites sent back for another team and waggon limber, and brought back the disabled gun under a concentrated fire from the enemy, who were not more than four hundred yards distant. Lieutenant Higgins, of the same battery, also distinguished himself for gallantry. One of the guns was overturned in a donga. In the face of a close and heavy fire the Lieutenant succeeded in righting the gun and bringing it into a place of safety."

The following is a list of killed and wounded among the officers who were engaged on Lombard's Kop:—

13th Field Battery, R.A.—Major John Dawkins, wounded, slightly. 42nd Field Battery.—Lieutenant James Taylor M'Dougall, killed. 69th Field Battery.—Lieutenant Harold Belcher, bullet wound, forearm, severely. 1st Battalion King's Royal Rifles.—Major W. T. Myers (7th Battalion), Lieutenant H. S. Marsden, and Lieutenant T. L. Forster, killed; Lieutenant H. C. Johnson, bullet wound in shoulder, severely. 2nd Battalion King's Royal Rifles.—Major H. Buchanan Riddell, bullet wound, abdomen, severe. 1st Battalion Gloucestershire Regiment.—Captain Willcock, bullet wound, shoulder and wrist; Captain Bertram Fyffe, bullet wound, forearm and chest, severe; Captain Frederick Staynes, bullet wound, forearm, severe. Royal Army Medical Corps.—Major Edward G. Gray, killed. Natal Mounted Rifles.—Lieutenant W. Chapman, killed.

THE DISASTER OF NICHOLSON'S NEK

The circumstances which attended the movements of Colonel Carleton's column are even now somewhat fraught with mystery. He carried out the night march unmolested until within two miles of Nicholson's Nek. Then some boulders, loosened evidently for the purpose, rolled down the hill, and a sudden crackling roll of musketry stampeded the infantry ammunition mules. The alarm became infectious, with the result that the battery mules also broke loose from their leaders, practically carrying with them the whole of the gun equipment. The greater part of the regimental small-arm ammunition reserve was similarly lost. In consequence of this misfortune, Colonel Carleton's small force, after a plucky fight and heavy loss, had to capitulate. The real truth about the affair may never be known, but for the lamentable result Sir George White in an official dispatch, with heroic courage—greater perhaps than any required by warriors in the field—took upon himself the entire blame. The General knew well that the failure of his programme in the engagement of Lombard's Kop had inevitably brought about the disaster to the isolated force.

[Pg 46]

The list of officers taken prisoners by Boers was as follows:—

Staff.—Major W. Adye. 1st Battalion Royal Irish Fusiliers.—Lieutenant-Colonel F. R. C. Carleton; Majors F. H. Munn and C. S. Kincaid; Captains Burrows, Rice, wounded, and Silver, severely wounded; Lieutenants A. E. S. Heard, C. E. Southey, W. G. B. Phibbs, A. H. C. MacGregor, H. B. Holmes, A. L. J. M. Kelly, W. D. Dooner, wounded; Second Lieutenants R. J. Kentish, C. E. Kinahan, R. W. R. Jeurwine; Chaplain Father Matthews. 1st Battalion Gloucestershire Regiment.—Majors S. Humphrey, H. Capel Cure, and W. R. P. Wallace; Captains S. Duncan and R. Conner, both slightly wounded; Lieutenants A. Bryant, F. C. Nisbet, J. O'D. Ingram, R. M. M. Davy, C. S. Knox, W. A. M. Temple, A. H. Radice, F. A. Breul, W. L. B. Hill, P. H. Short; Second Lieutenants H. H. Smith, W. S. Mackenzie, R. L. Beasley, Lieutenant and Quartermaster R. J. Gray. Royal Artillery Mountain Battery.

Some details of their misfortune were given by the prisoners in Pretoria, and they serve to throw more light on the subject.

Colonel Carleton, as we know, was sent towards Nicholson's Nek to hold it and prevent the Free Staters from coming to the assistance of the other Boers. Having lost his reserve ammunition and the water of all the battery through the stampede of the mules, he set to work to construct a defensive position. But stones were scarce and the defences were slender, and by the light of dawn his position was revealed. At this time a long-range fire was opened from three hills to south and west, dropping from 1500 yards into the position, and taking it both in flank and in rear. From his observations Colonel Carleton discovered that General White's scheme had failed—that it was being abandoned. In consequence of this failure the whole Boer force was enabled to swarm from all directions towards the isolated column. Firing fierce and incessant, exhausted the already worn-out Irish Fusiliers, while the advanced companies of the Gloucesters were severely mauled by the Martini bullets of the enemy. The hill was now completely surrounded, the ammunition expended; still Colonel Carleton had no idea of giving in. The bayonet was left, and by the bayonet he meant to stand or fall. Suddenly a wounded officer ordered the white flag to be raised. It was then hoisted, but uncertainty prevailed as to the authority for the exhibition of the flag, and some of our men still continued to fire. However, the mischief was done, and the surrender was merely a matter of moments.

[Pg 47]

The most vivid account of the disaster, from an outsider's point of view, was given by the *Times* special correspondent at Ladysmith. He wrote:—

"This column, consisting of six companies of the Royal Irish Fusiliers, four and a half companies of the Gloucestershire Regiment, and No. 10 Mountain Battery, left camp on Sunday night at 10.30, with the object of occupying a position from which it would be able to operate upon the right of the Boer position on Pepworth Hill. The column was guided by Major Adye, of the Field Intelligence, and a staff of the headquarters guides. Their destination was Nicholson's Nek, a position which, when reconnoitred from this side, appeared to possess the necessary tactical advantages for a detached force. Nicholson's Nek lies about four miles up Bell's Spruit, a donga due north of Ladysmith. The men blundered along in the darkness, the Irish Fusiliers leading, the battery in the centre, the rear being brought up by the Gloucestershire Regiment. There seems no doubt upon one point, and that is, the enemy were aware of this part of the movement from the beginning. Probably they were aware of the whole of the plans for Monday, for in Ladysmith it was impossible to say who was a Boer agent and who not. However that may be, it is certain that the enemy were on the flanks of the column all night, one of the survivors positively stating that he constantly heard the snapping of breeches, and once the peculiar noise which a rifle makes at night when it is dropped.

"Two hours before daybreak, while the column was in enclosed country, either a shot was fired or a boulder rolled into the battery in column of route. The mules stampeded, and easily broke away from their half-asleep drivers. They came back upon the Gloucestershire Regiment, the advance party of whom fired into the mass, believing in the darkness that it was an attack. This added to the chaos; the ranks were broken by the frenzied animals, and they dashed through the ranks of the rearguard, carrying the first and second reserve ammunition animals with them. It became a hopeless panic; the animals, wild with the shouting and the turmoil, tore down the nullah into the darkness, and the last that was heard of them was the sound of ammunition-boxes and panniers as they were splintered against the boulders. The hubbub of those few minutes was sufficient to have alarmed the enemy. By a strenuous effort the officers succeeded in getting the men again under control, and when daylight came they seized the first position which presented itself, and which was about two miles short of the original goal. They were forced to take advantage of the first kopje, as Boer scouts were all round them, and the day was ushered in with desultory firing. It was a sorry position which they had chosen, and the men were in a sorrier plight. All their reserve ammunition was gone, and though they had saved pieces of the screw-guns, they were not able with these pieces to patch up a single mounting.

"The position itself was a flat kopje commanded on the south by a self-contained ridge. To the east was another kopje, which commanded the top of the position at about 500 yards. On the west were two similar spurs, also commanding the position at short ranges. The summit of the kopje was a plateau, all the sides being gradual slopes except the eastern, which was almost sheer, this latter being the side from which access had been gained. From below it appeared a defensible position, but when once the top was reached it was evident that it was commanded from all sides. The men busied themselves attempting to build breastworks. The Gloucestershire companies, with their Maxim gun, were given the northern face to hold, two companies being detached on to a self-contained ridge of the position which lay on the south side. The Irish Fusiliers had the precipitous flank to defend.

[Pg 48]

"From earliest daybreak Boer scouts were reconnoitring, and about eight o'clock mounted Boers could be seen galloping in small groups to the cover at the reverse of the hill on the west. Later two strong parties of mounted men took position on the far side of the two hills commanding the kopje from the west. About nine o'clock these two parties had crowned the hills and opened a heavy fire at short ranges right down upon the plateau. Our men made a plucky attempt to return this fire, but it was impossible; they were under a cross-fire from two directions, flank and rear. The two companies of Gloucesters holding the self-contained ridge were driven from their shelter, and as they crossed the open on the lower plateau were terribly mauled, the men falling in groups. The Boers on the west had not yet declared themselves, but about 200 marksmen climbed to the position which the two companies of the Gloucesters had just vacated. These men absolutely raked the plateau, and it was then that the men were ordered to take cover on the steep reverse of the kopje. As soon as the enemy realised this move, the men on the western hill teemed on to the summit and opened upon our men as they lay on the slope. They were absolutely hemmed in, and what had commenced as a skirmish seemed about to become a butchery. The grim order was passed round—'Faugh-a-Ballaghs, fix your bayonets and die like men!' There was the clatter of steel, the moment of suspense, and then the 'Cease fire' sounded. Again and again it sounded, but the Irish Fusiliers were loth to accept the call,

and continued firing for many minutes. Then it was unconditional surrender and the men laid down their arms."

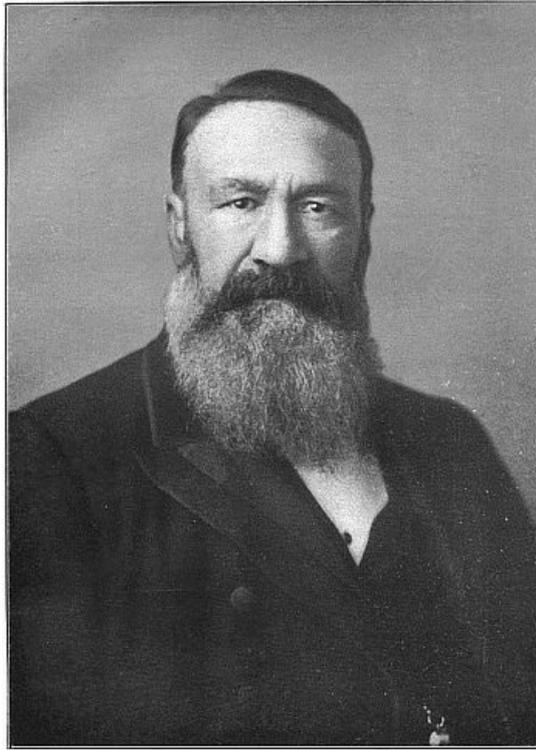

GENERAL JOUBERT.

Photo by Elliott & Fry, London.

An officer of the Gloucestershire Regiment described the affair thus:—

"HOSPITAL, WYNBERG, 9/11/1899.

"We were ordered out with six companies of Royal Irish Fusiliers and No. 10 Mountain Battery, Royal Artillery, to make a night march through the Boer lines and hold a hill behind their right flank till the rest of the troops took us off, which they expected to do about 11 A.M. As it turned out, they were not able to do this, but they did keep the Boer guns employed, luckily for us. We started off at 8.30 P.M., and got to the foot of our hill about 2 A.M. The Royal Irish Fusiliers were in front, then the battery and S.A.A. mules, and last ourselves. The Royal Irish Fusiliers had got part way up the hill—a very steep one—when three mounted Boers galloped down amid clouds of dust, rolling stones, &c. They started off the battery and S.A.A. mules, the Boers firing as they passed. The mules cut right through the regiment, and all was chaos for a time.

"It was pitch dark, and the noise of the mules and the loads and the stores falling about was enough to put any one off. Several men were hurt, some got in next day, some are missing.—Part of Stayner's, Fyffe's, and my company were cut off from the rest altogether, and when we got them in some sort of order, we had quite lost the rest of the column. The orders were to push on, no matter what happened, and every one left to look out for himself. After some time trying to find the path, we came across a straggler, who told us which way the regiment had gone, and eventually we found them on the top of a hill. We were ordered, as soon as we got on the hill, to put up sangars, which we worked at by the light of a very small moon till daylight. Then the Boers began on us all round, not very many, till about half-past eight. From then till 2.30 the fire was hot, and hottest at 2.30, when our ammunition being almost down and the fire devilish from all sides, we had to give in.

[Pg 49]

"I got a grazing shot on my left hand and a bullet in my right forearm early (about 8.30 A.M., and two more grazers—right thigh and left elbow)—later, finally, a bullet from behind through the right shoulder about a quarter of an hour before the end. I don't know who gave the order to 'Cease fire.' The firing could not have gone on five minutes more on our side for want of ammunition, and the Boer fire was tremendous from all round. It was like 'magazine independent' at the end of field-firing. The astonishing thing is so few were hit. If we had had our guns and ammunition, I think we could have held on until night and then got off, but there were 1200 of them, they said, to our 800, not counting gunners, and you could not till the very end see a dozen of them. The way they take cover is simply wonderful. All the prisoners were marched off at once and sent by rail to Pretoria. It was a terribly hot day, and no shade or water except what the Boers gave us. They were very good about water, giving us all they had, and fetching more from the bottom of the hill, one and a half mile away."

An officer of the Royal Irish Fusiliers, writing from Staatsmodel Schule, Pretoria, said:—

"We were all taken prisoners, together with the Gloucester Regiment and a Battery of Mounted Artillery, which accounts for us being in Pretoria so soon. As we were going up the hill in the dark, a small party of Boers dashed through our ammunition mules, causing them to stampede. By this move we lost all our mules, 200 in all, and with them all our ammunition and artillery.... You don't know what it means shooting a Boer; he is behind a rock, and all you can ever see is his rifle sticking out. For the last hour of the fight I had a rifle and ammunition which I took from a dead man, and blazed away for all I was worth. Then we fixed bayonets and prepared for a rush, when the 'Cease fire' sounded. Our senior Captain has told me that my name has been mentioned to our Colonel, who was commanding the force, as having caused a lot of men to rally. We were all then taken prisoners, except two officers killed and eight wounded, and marched to the Boer laager, and sent off that night

to a station twenty miles distant in waggons. While we were in their laager they treated us extremely well, and gave us food and tobacco. All you read about the Boers in England is absolutely untrue. They are most kind to the wounded and prisoners, looking after them as well as their own wounded, and anything they've got they will give you if you ask them, even if they deprive themselves. We came up to Pretoria in first-class sleeping-carriages, and the way they treated us was most considerate, feeding us and giving us coffee every time we stopped. The day we arrived we took up quarters on the racecourse, but we have been moved into a fine brick building with baths, electric light, &c. They provide us with everything, from clothes down to tooth-brushes. They also feed us, and we are constantly getting presents of vegetables and cigars from private people. In fact, we can have everything we like except our liberty; for some reason or other they won't at present give us parole, and we are surrounded by sentries. There are close upon fifty officers in this building, and they have got any amount of wounded ones in different places. They say they won't exchange the officers at any price."

[Pg 50]

As this letter had evidently to pass through the hands of the prison censor, we may take the eulogies of the Boers for what they were worth! However, it is but just to own that there are Boers and Boers. For instance, it is a fact that Captain Gerard Rice, who was wounded in the ankle and unable to move, offered a Boer half-a-sovereign to carry him off the field. The man refused the money, but performed the action with great kindness.

Father L. Matthews, chaplain of the Royal Irish Fusiliers, who was captured at Nicholson's Nek on October 31 and subsequently released, gave the following version of the disaster:—

"We were sent out to occupy the position with the object of preventing the two Boer forces from joining. We started at 8.30 on Sunday night, marched ten miles, and got to the hill at 1 A.M. The first mishap was that the mountain battery stampeded and scattered the whole lot of mules. We formed up again and gained the top of the hill. The guns were gone, but not all the ammunition. I do not know what stampeded the mules. They knocked me down. It was pitch dark.

"We had one hour's sleep. Firing began just after daylight. It was slack for some time, but the Boers crept round. Then the firing became furious. Our men made a breastwork of stones.

"After 12 o'clock there was a general cry of 'Cease fire' in that direction. Our fellows would not stop firing. Major Adye came up and confirmed the order to cease fire. Then the bugle sounded 'Cease fire.' In our sangar there was a rumour that the white flag was raised by a young officer who thought his batch of ten men were the sole survivors.

"We were 900 alive, having started perhaps 1000. I think that many of the battery men escaped. Our men and officers were furious at surrendering. The Boers did not seem to be in great numbers on the spot, but I heard that the main body had galloped off.

"The men had to give up their arms. The officers were sent to Commandant Steenekamp. The officers then ordered the men to fall in. The officers were taken away from the men and sent to General Joubert. On the same day the officers went in mule-waggons and slept at some store *en route*, and next day took the train at Waschbank for Pretoria. The officers are very well treated, and so, I have heard, are the men. There has been no unpleasantness in Pretoria. The officers are in the Model School, and are allowed to walk as they please in the grounds.

"I think that the surrender was a great blunder, and was caused by a misunderstanding. Major Adye was much put out. The white flag was not hoisted by the Irish Fusiliers."

Father Matthews puts the case mildly. Some of the officers of the Irish Fusiliers were so exasperated at the exhibition of the white flag, that they set to work and smashed their swords rather than give them up.

[Pg 51]

The final figures of the losses sustained at Nicholson's Nek were as follows: The total of missing of the Gloucesters and Royal Irish Fusiliers was 843. Thirty-two of the Gloucesters, 10 of the Fusiliers, and 10 of the Mountain Battery were found dead on the field, while 150 wounded were brought into camp at Ladysmith. Between 70 and 100 of the men escaped and got back to camp.

THE SIEGE OF LADYSMITH

It was now found necessary to issue a proclamation giving all strangers the option of leaving the town at twenty-four hours' notice. In spite of this notice, however, many civilians remained. Meanwhile, shells continued to drop uproariously, if harmlessly, into the town, while the balloon corps worked steadily in their task of locating the hostile guns. The enemy objected to that original form of spy, and aimed at him many a shot, but, fortunately, without effect. The Naval Brigade, always animated, active, and efficient, completed the mounting of the long-range guns which were to add to the safety of the place and the discomfiture of its besiegers. On the whole, the position was becoming somewhat serious, particularly for those whose nerves were unaccustomed to the uproar of diurnal thunderstorms. Lord Wolseley has somewhere said that "the effect of artillery fire is more moral than actual; it kills but very few, but its appalling noise, the way it tears down trees, knocks houses into small pieces, and mutilates the human frame when it does hit, strikes terror into all but the stoutest hearts." It may be imagined that the early days of this experience must have been somewhat embarrassing, though later on, so attuned became the nerves, even of women, that they engaged in shopping in the midst of bombardment, quite unmoved.

On 2nd November at 2.30 P.M. the telegraphic communication with Ladysmith was interrupted, but it was undecided whether the Boers had got sufficiently far south to promote the interruption or whether the wires had been cut by Dutch sympathisers or small scouting parties of the enemy. The Boers applied for an armistice with a view to burying their dead, their real object most

probably being, as in many previous cases of a similar nature, to obtain time for refitting their heavy guns. This request was refused, but they were permitted to bury their slain under a flag of truce. Meanwhile, General Joubert's force received large reinforcements of Free State burghers under the command of Lucas Meyer, and additional commandoes from the Middleburgh and Leydenburg districts under Schalkburger were expected.

After this the siege of Ladysmith began in real earnest. "Long Tom," though temporarily incapacitated, soon resumed his volubility, and was assisted by another of his calibre nicknamed "Slim Piet." Curiously enough, the first house hit during the siege was a commodious bungalow-shaped residence with large verandah belonging to Mr. Carter, the author of the now well-known "Narrative of the Boer War." The owner fortunately had left before the bombardment, and the premises were then occupied by nurses.

[Pg 52]

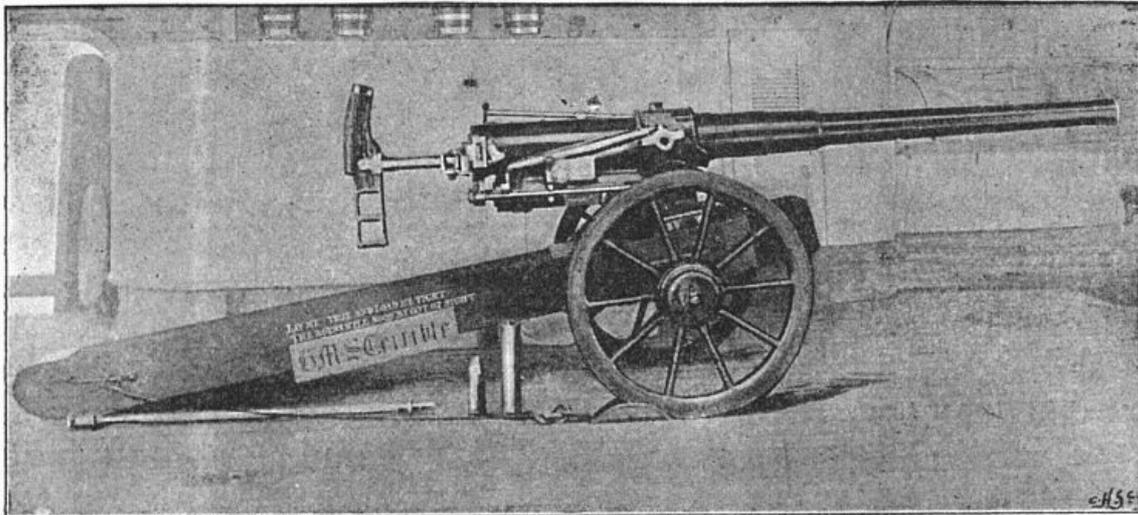

TYPES OF ARMS—12-POUNDER NAVAL GUN ON IMPROVED CARRIAGE

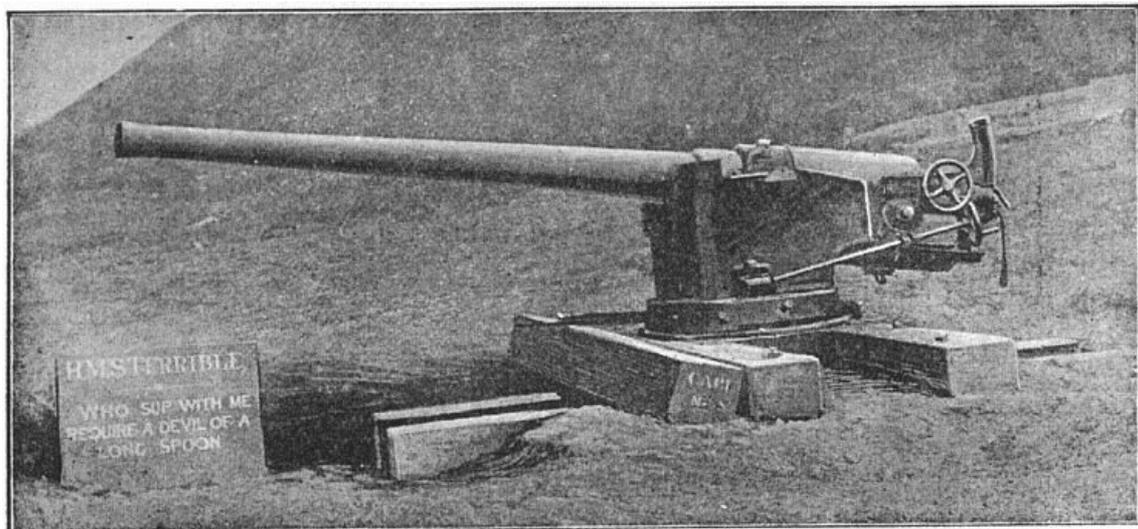

TYPES OF ARMS—4.7-INCH NAVAL GUN ON IMPROVED MOUNTING

Lieut. Frederick Egerton, of the *Powerful*, who was wounded by a shell in the left knee and right foot, was promoted to the rank of Commander in Her Majesty's fleet for special services with the forces in South Africa. But his promotion came too late. He expired after some hours of suffering.

[4]

The Boers by now had established batteries on Grobler's Kloof, a commanding eminence from whence they could attack both Ladysmith on the north and Colenso on the south. Women and children vacated the place, and the trains coming in and out had to run the gantlet of the Boer fire, both Nordenfeldt quick-firing guns and Mauser rifles being brought to bear on the refugees. The Boers, however, continued to salute the town without much effect, while the naval gunners replied with telling emphasis. They succeeded in dismounting the Boers' 40-pounder which had been so comfortably posted on Pepworth's Hill.

[Pg 53]

The carriages and platforms on which the naval guns were mounted at Ladysmith, and which proved so important a feature in promoting the defence of the place, were specially designed by Captain Percy Scott of the cruiser *Terrible*. In regard to this officer's resourcefulness the *Times* expressed an opinion that is worthy of remembrance:—

"Captain Percy Scott, of the *Terrible*, came to the rescue, adding one more to the numerous instances in which this country has owed to individual resource and initiative its escape from the disasters invited by the incompetence of the War Office. There is no need to inquire just now into

the balance of political and military considerations which determined the policy of making a stand at Ladysmith. It is enough that that policy was definitely adopted in ample time to allow of providing Ladysmith with the long-range guns which its position renders peculiarly necessary, dominated as it is by hills on three sides. Why were such guns not provided? Why was it left to fortunate accident to furnish the garrison at the very last moment with the means of defence? The conclusions of German military science, as will have been noted by all who read the interesting account of German manœuvres which we published yesterday, are all in favour of saving the lives of the infantry by a very free use of artillery at long ranges. The country around Ladysmith seems to be one that calls loudly for even a more lavish artillery equipment than might normally suffice. Yet, in spite of science and of common-sense, the Ladysmith garrison, occupying a predetermined position open to artillery fire from all sides, was left absolutely destitute of long-range guns, and none too well provided with field-artillery. But that Captain Scott proved himself able, just in time, to improvise out of the rough materials at hand an effective gun-carriage, there would have been nothing to prevent the Boers from using their big guns at half the distance they have actually had to keep."

At this time British troops were withdrawn from Colenso and moved farther south, and Boer armies continued to close round Ladysmith. Isimbulwana Hill, lying east of Ladysmith, was taken possession of, and a force advancing from Dewdrop, on the west of the town, moved south towards Colenso, and there on high ground posted its guns. Yet, in spite of this, the town showed itself to be "all alive and kicking." Though cut off from the telegraph, it sent out pigeon-posts; though engirdled by Boers, it made sorties of the most animated description, and literally laughed at the hint of surrender. On the 2nd, Colonel Brocklehurst made an attack on the enemy's laagers with a force of cavalry, mounted infantry, and mounted volunteers, surprising the Dutchmen and driving them back with comparatively small loss, and on the following day fighting lasted for some hours between the British cavalry, supported by field-artillery, Imperial Light Horse, and Natal Mounted Volunteers, and the Republicans. Many shells were pitched into the town, and an artillery duel rampaged with such relentless vigour that the general sensation to those who remained enclosed in the town was as though a thunderstorm with earthquake was passing over the place. Nothing worse happened, and the enemy for a while were driven back to their camp and some thirty or more prisoners were taken. Major Charles Kincaid, 1st Royal Irish Fusiliers, with nine wounded prisoners, was exchanged by the Boers for eight of their countrymen in similar plight. Others of them were not fit to travel. The enemy continued active, replacing disabled guns with new ones and dragging fresh powerful weapons to bear on the situation. On the 4th of November they announced their annexation of Upper Tugela, and a counter-proclamation of the nature already quoted was issued by the Governor.

[Pg 54]

A large commando of the enemy commenced the bombardment of Colenso, and the troops forming the garrison of that place fell back on Estcourt, where was stationed a force of considerable strength. By "considerable strength" it must be understood that the force was sufficiently strong for purposes of defence, though not for purposes of offence. As a matter of fact, the force in Natal was not, and has not since been, sufficiently strong for attack of a foe in such powerfully entrenched positions. From beginning to end our military commanders on that side of the theatre of war were sorely handicapped by the tardy recognition by the Home Government of the gravity of the situation. But here it is now desirable that something should be said of the early history of the towns of Mafeking and Kimberley, which, like Ladysmith, were by this time almost completely isolated, rails and telegraph wires having been cut around both places respectively.



LADYSMITH, NATAL.

Photo by Wilson, Aberdeen.

FOOTNOTES:

- [1] Colonel Sherston, D.S.O., of the Rifle Brigade, in which he held the rank of Major, was a son of the late Captain Sherston, of Evercreech House, Somerset, and a nephew of Lord Roberts. He entered the army on February 12, 1876, and on the Afghan War breaking out two years later was appointed aide-de-camp to his uncle, then Sir Frederick Roberts. He was present in the engagement at Charasiah on October 6, 1879, and the subsequent pursuit of the enemy, his services being mentioned in despatches. A similar distinction

fell to his lot in connection with the operations around Cabul in 1879, including the investment of Sherpore. He accompanied Lord Roberts in the famous march to Candahar, and was present at the battle at that place, when he was again mentioned in despatches. His services during the operations were rewarded with the medal with three clasps and the bronze decoration. In 1881 he took part in the Mahsood Wuzeeer Expedition, and on August 20, 1884, he received his company. He served with the Burmese Expedition in 1886-87 as D.A.A. and Q.G. on the Headquarters Staff, and was again mentioned in despatches and received the Distinguished Service Order and the medal with clasp. On October 15, 1898, A.A.G. in Bengal.

- [2] Lieutenant-Colonel Robert Henry Gunning, of the 1st King's Royal Rifles, was the eldest son of Sir George William Gunning, fifth Baronet, of Little Horton House, Northampton, the Chairman of the Conservative Party in Mid-Northamptonshire, by his marriage with Isabella Mary Frances Charlotte, daughter of the late Colonel William Chester-Master, of the Abbey, Cirencester, and was born on July 17, 1852. Educated at Eton, he entered the army as a sub-lieutenant on March 26, 1873, and was gazetted to the 60th Foot (now the King's Royal Rifle Corps) as a lieutenant on September 9, 1874. He served in the Zulu War of 1879 with the third battalion of his regiment, and was present at the action of Gingindhlovu and the relief of Ekowe, afterwards serving as adjutant of the battalion throughout the operations of "Clarke's Column," for which he wore the medal with clasp. He was gazetted captain in August 1883, was an adjutant of the Auxiliary Forces (the 5th Militia Battalion of the King's Royal Rifles) from March 1886 to March 1891, having obtained the rank of major on June 25, 1890. In 1891-92 he took part in the war in Burma, being engaged in the operations in the Chin Hills in command of the Baungshe column, for which he wore a second medal with clasp. His commission as lieutenant-colonel bore date April 16, 1898. Colonel Gunning, who was in the Commission of the Peace for the county of Northants, married in 1880 Fanny Julia, daughter of the late Mr. Clinton George Dawkins, formerly Her Majesty's Consul-General at Venice.
- [3] Colonel John James Scott Chisholme, who was killed at Elandslaagte, belonged to the 5th (Royal Irish) Lancers, and who was detached on special service in South Africa, came of an old Scottish family, the Chisholmes of Stirches, Roxburghshire, his family seat being situate at the latter place. He was the only son of the late Mr. John Scott Chisholme (who assumed the name of Scott in 1852 under the will of his uncle, Mr. James Scott of Whitehaugh), by his marriage with Margaret, eldest daughter and co-heir of the late Mr. Robert Walker of Mumrells, Stirlingshire, and was born in 1851. He entered the army in January 1872, his first services being with the 9th Lancers, and reached the rank of captain in March 1878. From that year till 1880 he served with the 9th Lancers in the Afghan War, was present at the capture of Ali Musjid, took part in the affair of Siah Sung, where he was severely wounded, and in the operations around Cabul in December 1879, when he was again wounded, and obtained mention in despatches, being rewarded with the brevet of major (May 2, 1881), and the medal with two clasps. He reached the substantive rank of major in December 1884, and from that year till 1889 was a major of the 9th Lancers, when he was transferred to the 5th Lancers. He was Military Secretary to Lord Connemara when Governor of Madras from 1888 to 1891. He reached the rank of lieutenant-colonel in August 1894, and that of colonel on August 12, 1898.
- [4] Commander Egerton was a nephew of the Duke of Devonshire and of the first Earl of Ellesmere. He was the son of the late Admiral the Hon. Francis Egerton, M.P. for East Derbyshire, 1868-86. Commander Egerton, who was in his thirty-first year, entered the navy seventeen years ago. He became a lieutenant in 1891, and in 1897 he was appointed gunnery officer in the cruiser *Powerful*, having specially qualified in gunnery. He possessed honorary certificates from the Royal Naval College, but he had had no previous experience of war service.

CHAPTER II

THE SIEGE OF MAFEKING

President Kruger's Ultimatum having been accepted in its full significance, General Cronje crossed the border and the telegraph wires to Mafeking were cut. Mafeking is a smart little town on the Bechuanaland Railway. It stands about eight miles from the Transvaal border, about 200 miles north of Kimberley, and some 875 miles from Cape Town. It is the headquarters of the Bechuanaland Border Police, a crack corps, whose every member is thoroughly wide-awake and well versed in the niceties of the guerilla style of warfare favoured of the Boers. In the town is the "Surrey Hotel" and others; English, Dutch, and Wesleyan churches; a cricket-ground and a racecourse. Its supplies, in time of peace, are drawn from Dutch farms situated in the Marico Valley, while its pure water is drawn from the springs at Rooi Grond in the Transvaal territory.

Mafeking itself is less than a mile square. The railroad, running north and south, takes a westerly bend as it crosses the Molopo River some 300 yards south of the town. In this westerly direction is a native Stadt, a constellation of mushroom huts wherein the blacks congregate. To east, north, and west the surrounding country is flat; elsewhere it rises and affords a certain amount of cover. Towards the south-east is Sir Charles Warren's old fort, named Cannon Kopje, which was viewed as the key of the position and promptly rendered impregnable. In the north-west corner of the town was the railway station, now useless; on the north-east, the convent; on the south-east, Ellis House; and south-west, the Pound, near which were the quarters of the British South African

Police. The population of the town consisted of some 2000 whites, while in the Stadt, owing to the presence of native refugees, there were about 7000 blacks.

On the outbreak of hostilities, Colonel Baden-Powell, who had been sent out on special service to South Africa to report on the defences of Rhodesia, applied himself at once to face a situation which made demands on all his extensive capabilities. In the very early days of the investment he got guns into position and made dashing sorties, determining to show the besiegers that they would not have what in popular phrase is known as "a walk over." So great was the versatility of this officer, that, while these energetic measures for the protection of those around him were going forward, he yet managed to correct and send home proofs of a "Manual on Scouting," a work at the moment most interesting and precious to the military man, while to the layman it makes as good reading as the "Adventures of Sherlock Holmes." In Mafeking was also Major Lord Edward Cecil (Grenadier Guards), D.S.O., the fourth son of the Prime Minister—whose activity and energy were remarkable, even in a community where those qualities were ubiquitous—and Captain Gordon Wilson (Royal Horse Guards), with his wife, Lady Sarah Wilson, a lady of much enterprise, to whose energies the garrison owed not a little. Among others there were Colonel Hore (South Staffordshire Regiment), Major Godley (Royal Dublin Fusiliers), Captain Marsh (Royal West Kent Regiment), Captain Vernon (King's Royal Rifles), Captain FitzClarence (Royal Fusiliers), Lord Charles Cavendish-Bentinck (9th Lancers), the Hon. H. Hanbury-Tracy (Royal Horse Guards), Lieut. Singleton (Highland Light Infantry), Captain the Hon. D. Marsham (4th Bedfordshire Regiment), Captain Pechell (3rd King's Royal Rifles), and Major Anderson (R.A.M.C.). There were in addition several Colonial officers who proved themselves the soul of activity—notably Captain Goodyear, Captain Nesbitt, V.C., Lieuts. Paton and Murchison, and several others. Colonel Vyvyan and Major Panzera also worked like Trojans to secure the safety of the town. Major Baillie of the *Morning Post* made himself useful in every capacity. Later on he forwarded a description of the garrison which gave a good idea of the splendid plan of organisation adopted. He said:—

[Pg 56]

"The town was garrisoned by the Cape Police under Captains Brown and Marsh. These and the Railway Volunteers were under Colonel Vivian, while Cannon Kopje was entrusted to Colonel Walford and the B.S.A.P. Colonel Baden-Powell retained one squadron of the Protectorate Regiment as reserve under his own immediate control. These arrangements were subsequently much augmented. After the convent had been practically demolished by shell-fire, and the railway line all round the town pulled up or mined during the close investment by the Boers, the small work was erected at the convent corner, garrisoned by the Cape Police and a Maxim under Lieutenant Murray, who was also put in charge of the armoured train, which had been withdrawn to the railway station out of harm's way.

"The Railway Volunteers garrisoned the cemetery, and had an advance trench about 800 yards to the front and immediately to the right of the line. To the westward came Fort Cardigan, and then again Fort Miller; to the south-west was Major Godley's Fort, at the north of the native stadt, with Fort Ayr, and an advance fort crowning the down to the northern end of the stadt, and though rather detached, having command of the view for a great distance. To the south of the northern portion of the stadt the Cape Police were intrenched with a Maxim, and 500 yards to the west front of Captain Marsh's post lay Limestone Fort, commanding the valley, on the other side of which lay the Boer laager and intrenchments. At the south-western corner, and on the edge of the stadt Captain Marsh's fort was situated. The whole of the edge of the stadt was furnished with loopholes and trenches, and was garrisoned by the native inhabitants. Near the railway were situated two armoured trucks with a Nordenfeldt, and Cannon Kopje with two Maxims and a 7-pounder lay to the south-east. And now to the immediate defences of the town. At the south-western corner is the Pound, garrisoned by Cape Police under Captain Marsh, then eastwards is Early's Fort, Dixon's Redan, Ball's Fort, Ellis's corner, with Maxim and Cape Police, under Captain Brown. On the eastern front are Ellitson's Kraal, Musson's Fort, De Kock's Fort with Maxim, Recreation Ground Fort. To the left of the convent lies the Hospital Fort. All these, unless otherwise mentioned, are defended by the Town Guard."

[Pg 57]

Operations began on the 12th with an episode that cannot afford to be forgotten. It was discovered that two trucks of dynamite were in the station yard, and it was at once decided, for the safety of the population, that they must be removed. An engine was, therefore, despatched in charge of a plucky driver (Perry) for the purpose of conveying the trucks into the open, where they might explode without danger to the town. While he was engaged in the work of deporting the destructive material, the enemy suddenly appeared and commenced to fire. Perry, with the utmost coolness, a coolness which in the circumstances was nothing less than heroism, uncoupled his engine, and leaving the trucks to their fate, steamed back to the town. Before he could reach his destination, however, the shock of an awful detonation greeted his ears. The Boers had again fired on the trucks, believing them to be full of passengers, and, as a natural consequence, the dynamite had exploded!

The garrison, numbering from 800 to 1000, now began to furbish itself up, to arm and practise with the rifle. The old forts round the place were put into repair, and the armoured train, with a Maxim gun and a Nordenfeldt, was made ready for coming excursions. Nothing was neglected. It was well known that the Boers looked upon the town as their personal property, and when it came to fighting, meant to make it so—if they could! The two available regiments, the Protectorate Regiment and the Mounted Police, spent most of their time manœuvring, with a view to awakening the intelligent interests of the ranks and instructing the men on the nature of the ground in the vicinity. Colonel Baden-Powell lost no opportunity of preparing for the gallant Cronje, and, in order to show that he did not mean to be caught napping, some nights were passed by the garrison in their day kit.

On the 12th October an armoured train that was escorting two light guns of old pattern from the Cape to Mafeking was seized by the Boers, who had torn up the rails at Kraalpan. They pounded

the machine with artillery, and captured it with guns and men in charge—all, save the engine-driver, being made prisoners. Lieutenant Nesbitt was wounded and the driver lost five fingers. The latter escaped through hiding himself in the sand and thus avoiding observation. In Mafeking itself the Sisters of the Roman Catholic Convent busied themselves. These noble women refused to leave the place, electing to remain face to face with danger in order to nurse the sick. Many of the houses were converted into hospitals, all the streets were barred with waggons, and even the inhabitants of the town were supplied with rifles and taught the use of them. The telegraph wires were now cut at Maribogo, some forty miles south of Mafeking. The bridge that crossed the Molopo River above Mafeking was next blown up by the Boers with tremendous uproar. Still the inhabitants were not dismayed. They had implicit confidence in their commander and worked incessantly. As a defensive position, Kimberley, whose history will be told later, had the advantage of Mafeking. The refuse heaps from the mines at the former place served as natural fortifications. But Mafeking was in one way fairly secure: its troops, though few, were efficient, and owing to its not being the abode of Mr. Rhodes, it was no longer looked upon by the Boers as the most attractive prize of the war. Besides this, Colonel Baden-Powell's plans of defence were very complete.

The town was divided into sections, each one of which had its separate arrangements for defence. The perimeter was about six miles in circumference. Huge earthworks were thrown up. Shelters were built, with panellings and roofings of corrugated iron. Colonel Baden-Powell had decided to hold the town, and declared that if he should hold it at all, his grip should be a firm one. For himself, he constructed a bomb-proof bureau, where his literary work could safely be pursued, if need be, to the accompaniment of a score of guns, and round him were telephonic communications with each of his outposts. He had also a private signaller placed with telescope on the watch to inform him of outside doings and forewarn the garrison in case of assault. Wire communications were arranged so that each discharge of a shell might be reported by an alarm, in order that inhabitants of the threatened quarter might have time to burrow in places of safety. During the daytime the bell of the signaller was actively employed, but at night the Boers seldom bombarded the place, and its inhabitants were free to emerge from their hiding-places and breathe the fresh air.

Fortunately in the matter of food much foresight had been exercised. With everything against him, Colonel Baden-Powell had succeeded in making provision for, if necessary, a prolonged state of siege.



**COLONEL ROBERT S. BADEN-
POWELL, THE DEFENDER OF
MAFEKING.**

Photo by Elliott & Fry, London.

At daylight on the 14th, the whole garrison was on the alert. Reports declared the Boers to be advancing on the south. Firing was at the same time heard from the north, and Lord Charles Cavendish-Bentinck was reported to be in action. While the firing continued the armoured train was hurriedly got in readiness, and started with the object of engaging the enemy.

The crew of the leading truck, "Firefly," consisted of a detachment of the British South African Police and Railway Volunteers, Captain Ashley Williams himself being in command, Mr. Gwayne being the driver of the engine, and Mr. A. Moffat acting as stoker. The second truck was in charge of Lieutenant More, an engineer on the Bechuanaland Railway. No. 1 truck was armed with a Maxim, and its crew mostly with Lee-Metfords. Truck No. 2, which carried another Maxim, rejoiced in the name of "Wasp." A third truck, the "Gun," carried a Hotchkiss. The crew of the

trucks numbered barely fifteen in each. The train, after passing Lord Charles Bentinck's squadron, who hailed it with a cheer and various humorous sallies, came on the enemy, about 500 strong, to right front of the trucks.

A fierce interchange of bullets followed, the Mafeking party firing with such success that the enemy cautiously withdrew into the distance; still they kept up a rattling fire against the armour of the train, which careered up and down the line for some time with imperturbable yet cheerful activity. Presently, however, Colonel Baden-Powell despatched Captain FitzClarence with a squadron of men to cover its retreat, but before this could be effected the Boers again appeared, and a determined engagement ensued. Some sharp fighting took place, and Captain FitzClarence, though ordered to return to Mafeking, was unable to do so without reinforcements on account of the number of his wounded. The phonophore having been connected with the railway line, a telegraph message to this effect was sent to headquarters. Thereupon Lord Charles Bentinck was ordered to take his squadron to the relief of Captain FitzClarence. Meanwhile Captain Ashley Williams and a party of the South African Police alighted from the train, and went unarmed to the assistance of the wounded. Among these was Lieutenant Brady of Queenstown. Soon, the helpless were removed into the trucks, and the train was steaming on its return to Mafeking after having done great execution among the enemy.

Travelling in an armoured train, even when you are not wounded, is scarcely an enjoyable experience; indeed, it may be described as one of the most superb tests of warrior qualities. The machine itself resembles a species of tank-truck, boxed round with seven-feet high walls of iron or steel, without doors or windows, and with no covering for the occupants save the dome of heaven. You climb in and you climb out as you would into a bath, by hanging on to the loopholes made for the rifles, and planting your feet on the exterior ridges that act as steps for the nimble toe. Once in, there is comparative safety. From all sides there is shelter from rifle-fire save when going down-hill below the enemy, who can then with ease pour cascades of bullets upon the heads of the travellers. The machine is painted kharki colour to make it less observable to the enemy, and has the distinction of being quite the ugliest of the many ugly inventions of modern science. Occasionally the exterior is of varied hue—particularly in green country, when it is made to look verdant and covered with boughs to give it an arboreal aspect, and render its shape less observable. But the ugliness and inconvenience of the train are nothing to the dangers it may have to encounter. The occupant may find himself surrounded by a party of the enemy before he has been a mile out from his base; he may find the rail cut behind him; he may steam straight into an ambush at any moment, or be blown up before he can wink. It has rightly been called a "death trap," for it provides chances of dissolution many and varied.

[Pg 60]

But notwithstanding these risks, the machine was at this time continually in use, and the pluck of the defenders of Mafeking rose superior to all tests. The engagement of the 14th, with all its thrilling and painful experience, bore good fruit; for all felt that the encounter had been beneficial in many ways, more especially in strengthening the sense of security that everywhere began to prevail. To show how much courage and determination was the order of the course, it must be noted, in somewhat Irish phrase, that the manning of the town was assisted by women, some of whom refused to go into laager, but elected to handle their Lee-Metfords for the protection of themselves and their companions.

In the engagement of this day, Lord Charles Cavendish-Bentinck and Lieutenant Brady were both slightly wounded. Major Baillie had a narrow escape, his horse having been shot under him, while his water-bottle was also struck by a bullet. In the evening Colonel Baden-Powell issued a general order congratulating the A and L squadrons, commanded by Captain FitzClarence and Lord Charles Bentinck, and the crew of the armoured train, under Captain Williams and Lieutenant More, for their highly creditable performances.

About this time some discomfort and anxiety was occasioned by the fact that water became scarce in the town, owing to the Boers having taken possession of a fountain from which the inhabitants were supplied. Still, as Colonel Baden-Powell is an officer of genius, full of resource and infinite capacity for taking pains, all had confidence that he would not allow himself to be overcome by a temporary difficulty, and that he and his would emerge from all tests much as Colonel Pearson and his gallant party emerged from the ordeal of Eshowe. So the water difficulty was soon settled. Under Major Hepworth's supervision all the wells were cleaned out, and Sir Charles Warren's old well re-opened. On the 16th of October Commandant Cronje's commandoes took up a position among the thorns above the racecourse and opened fire on the town. Then a Boer party bearing a flag of truce was sent by Cronje to demand surrender to avoid further bloodshed. "Certainly, but when will bloodshed begin?" asked Colonel Baden-Powell, who, alive to all the little dodges of his enemies, knowingly kept the Burgher messenger blindfolded while he formulated his reply. Of course he meant to hold out, and he said so in round terms, and the Burgher departed discomfited and without having secured a plan of the fortifications! Subsequently some Boer Krupp batteries were brought up to cover the town, to impress those concerned and to show that the enemy meant business. But the bombardment so far was not fraught with much damage, for Colonel Baden-Powell, telegraphing on the 21st, thus comically described the situation: "All well. Four hours' bombardment. One dog killed."

[Pg 61]



TYPES OF ARMS—15-POUNDER FIELD-GUN.

PHOTO BY CRIBB, SOUTHSEA.

The Boers had now begun to penetrate to Tuli in Rhodesia. Tuli is the nearest post on the north to Transvaal territory. It stands on a river that comes down from the Matopo Hills, and joins the Limpopo about twenty miles beyond the town, which commands the cross-roads from the Transvaal to Buluwayo and from Mafeking to Victoria. The troops here were under the command of Colonel Plumer, who, from the time that Mafeking was besieged, was untiring in his efforts to come to the rescue. With Colonel Plumer were the following officers: Majors Pilsen and Bird, Captain Maclaren (13th Hussars), the notable polo-player, Captain Blackburn (Cameronians), Captain Rolt (York and Lancashire Regiment), Lieutenant Rankin (7th Hussars), Lieutenant French (Royal Irish Regiment), and several others.

[Pg 62]

On the 19th of October a party of the enemy was suddenly met on the Rhodesian side of the river by a reconnoitring patrol. The Dutchmen fired on the patrol, wounding a trooper. Captain Glynn went off for the purpose of locating the enemy, and discovered the presence of a Boer column in his neighbourhood. Two days later a smart skirmish took place between a strong patrol and the enemy, who was encountered at Rhodes's Drift, with the result that two troopers were killed and two wounded. The Boers afterwards took up a strong position on a kopje at Pont's Drift, fired in a dastardly manner on Major Pilsen, Sergeant Shepstone, and his party while they were removing dead and wounded to an ambulance and a cart brought for the purpose, and their work of mercy had to be carried on under the most trying and aggravating conditions. There were also some skirmishes at Crocodile River. An armoured train got within about 1500 yards of a Boer laager three miles south of Crocodile Poort. Captain Blackburn (Cameronians) was seriously wounded and died on the road to Tuli, whither the British retired by Colonel Plumer's orders. It is satisfactory to note that Sergeant Shepstone, who gallantly came to Captain Blackburn's assistance, received his commission.

Skirmishing took place at odd intervals, and Colonel Plumer continued to send reconnoitring parties up and down the river. On many occasions these were fired upon, but without serious result. On the 28th, however, Captains White and Glynn reconnoitred a kopje at Pont's Drift—each approaching the hill on a different side—whereupon a brisk skirmish ensued, when five of their men were shot by the enemy and four wounded. Later on, after his reconnaissance westward along the Crocodile River, Colonel Plumer returned to Tuli. Boer commandoes were at that time supposed to have retired to the neighbourhood of either Pietersburg or Mafeking. Colonel Spreckley's camp was shelled by the enemy on the 3rd of November, and the mules and horses belonging to the squadron promptly stampeded.

To return to Mafeking. The Boers had now begun their activities, and miniature artillery duels were continually taking place between the British and the enemy. More guns were brought to bear upon the position by Cronje and his gang, and they set to work to do as much damage as possible. The Convent was hit, but no one was injured. Finally, after several days of bombardment and reciprocated shelling, Colonel Baden-Powell decided to give the enemy a taste of cold steel. A council of war was held, and on the 27th of October a most courageous night attack was made on the Boer trenches by Captain FitzClarence. As darkness descended, the little force stole noiselessly out of their stronghold with fixed bayonets, creeping like cats along the veldt, breath even being almost suspended lest a sound should put the enemy on guard. Then, on a given signal—a whistle from Captain FitzClarence—the men dashed forward on the foe, cheering lustily, while from the town the echoes and the voices of anxious watchers gave back cheer for cheer. The tussle was short and sharp. It was a case of fifty desperate men with fifty bayonets dealing destruction to a roaring rabble under the tarpaulins! Then came a storm of hostile bullets from the rear of the trenches, a swift reply from the attacking party, followed by Captain FitzClarence's whistle, "Cease fire. Scatter homeward." Under a withering fire the forces obeyed, returning as they went, in silence and in darkness. Then came the roll-call. Six were killed and eleven wounded, but of the latter all returned, none being left on the field. Here we may read Colonel Baden-Powell's general order:—

[Pg 63]

"The Colonel commanding wishes to record his high appreciation of the dash with which the attack on the enemy's trenches was carried out last night by D squadron of the Protectorate Regiment, under Captain FitzClarence, supported by the Cape Police under Lieutenant Murray. The whole operation was executed exactly as was wanted, and the results, though gained at the cost of several gallant

lives, were entirely successful and of great value. By this action the intention of the enemy to push their intrenchments to within rifle distance of the town has been checked, and the heavy loss that they have sustained has given them a wholesome fear of the dash of our men, and they have had an introduction to cold steel such as will not encourage them willingly to face it again. The steadiness of the Town-Guard on the east front was noticeable later in the night, when the enemy had a scare, and broke into wild firing, to which the guard made reply.—By order (Signed) E. H. CECIL, Major, C.S.O."

After this the Boers brought a big gun to bear on the position, and blazed away at a distance of seven miles from the town. Out of sixteen shells only one struck. This set fire to a store. The huge weapon evidently proved a white elephant, for before long the besiegers, much to the joy of the besieged, ceased their attempts to work it.

But heavy bombardment still took place. The Boer hosts attacked the town from three sides at once and were steadily repulsed by the British Maxims. All through the week Cronje's commandoes indulged in desultory rifle-fire, now and again throwing a shell by way of variety, to which attentions Colonel Baden-Powell and his smart garrison responded with such zest and animation, that the Boers, discomfited, declared that the place contained "not men, but devils!"

[Pg 64]

On Tuesday, the 31st of October, in the early hours of the morning, some hard fighting again took place. Colonel Walford and his detachment of the British South African Police held the fort called Cannon Kopje against an advance of the enemy, made under cover of four heavy guns and one 100-pounder. The affair ended in an entire defeat of the Dutchmen, but not before some gallant lives were sacrificed. The following order, issued the same day by Colonel Baden-Powell, describes the action:—

"The detachment of British South African Police forming the garrison at Cannon Kopje under the command of Colonel Walford, have this day performed a brilliant service by the gallant and determined stand made by them on their post in the face of a very hot shell-fire from the enemy. The intention of the Boers had been, after getting their guns and attacking force into position during the night, to storm Cannon Kopje at daybreak, and thence to bombard the south-east position of the town and carry it with a large force. They collected in the Molopo Valley. Their whole scheme has been defeated by the gallant resistance made by the garrison at Cannon Kopje, who not only refused to budge from their position under a cross-fire of artillery, but succeeded in inflicting such losses on the enemy as compelled them to retreat. In this way they were assisted by the timely and well-directed fire of a seven-pounder, under Lieutenant Murchison. The Colonel Commanding deplores the loss of the gallant officers and men who fell this day. By the death of the Hon. Douglas Henry Marsham and Captain Charles Alexander Kerr Pechell, Her Majesty loses two officers of exceptional promise and soldier-like qualifications. The Colonel Commanding believes he is giving voice to the feeling of the whole Mafeking garrison in expressing the deepest sympathy with the British South African Police in their loss. At the same time he congratulates Colonel Walford and his men on their brilliant achievement."

A pathetic funeral followed, the honoured dead being wrapped in the Union Jack, and buried by the grim light of a lantern, while the Rector and Roman Catholic Chaplain each said over the graves the last solemn words according to the rites of his Church. There was no Dead March, nor were any volleys fired, but the dumb grief of the community told its own tale of mourning.



NIGHT SORTIE FROM MAFEKING.

Drawing by R. Caton Woodville.

KIMBERLEY

Kimberley, as has been said, is by no means a picturesque place. On first acquaintance it appears to be surrounded by redoubts or forts, being dotted with mounds of greyish slag, technically called "tailings," which represent the refuse soil from which the diamondiferous ore has been extracted. The buildings are somewhat formal and unpleasing, being for the most part of corrugated iron, and conveying the impression that they are constructed with a view to being carried off at any moment. There are a few private residences, which the orthodox house-agent might style "handsome" or "commodious." The hotel is merely useful as a place for passengers to alight at and depart from, and that it is no more may be accounted for by the fact that Kimberley hospitality is so double-handed that visitors are seldom left to the tender mercies of public caterers. The Kimberley Club dispenses hospitality royally, and for this reason travellers are

[Pg 65]

made independent of outside luxury. Round Kimberley are the suburbs of Beaconsfield, Kenilworth, and Gladstone. Beaconsfield, which was once a growing town, has become stunted, while Kenilworth has blossomed forth under the auspices of Mr. Rhodes.

When the Boer Ultimatum was pronounced, all eyes turned naturally in the direction of the Diamond City, and as naturally the Diamond City, under the direction of Colonel Kekewich, prepared to defend itself. The population to be protected numbered some 33,000, of whom 19,000 were blacks. Among these latter were 4000 women. At that time it was doubtful if the Zulus, Matabeles, and Basutos were to be trusted, and consequently the position of the Colonel in supreme command was one of great responsibility. Fortunately the place was stocked with arms and ammunition, though the number of the regulars was absolutely inadequate to the requirements of so large an area.

The Imperial garrison sent to Kimberley for the defence only consisted of the 23rd Company Royal Garrison Artillery, with six 7-pounder mountain guns, Major Chamier commanding; one section of the 7th Field Company Royal Engineers, under Lieutenant M'Clintock; Captain Gorle and three non-commissioned officers and men of the Army Service Corps, and the headquarters and four companies of the Loyal North Lancashire Regiment, under Major Murray; in all, 564 officers and men. The staff included Lieutenant-Colonel Kekewich, North Lancashire Regiment, commanding; Major Scott-Turner, Royal Highlanders (staff officer); Captain O'Meara, Royal Engineers (Intelligence Officer); and Lieutenant MacInnes, Royal Engineers. The volunteer forces, when first called out for active service, consisted of one battery Diamond Fields Artillery, six 7-pounder field-guns, Major May, 3 officers, and 90 rank and file; Diamond Fields Horse, Major Rodger, 6 officers, 142 rank and file; Kimberley Regiment, Colonel Finlayson, 14 officers, 285 rank and file:—total all ranks, 1060.

The whole garrison was reviewed, and a town-guard was formed at Beaconsfield, under the command of Major Fraser. Colonel Harris commanded the Volunteers, most of these being employees of the De Beers mines. Preparations were made for the arrival of Mr. Cecil Rhodes, who was hastening to the scene of his early life-work, and for whose body, alive or dead, it was reported the Boers had sent out an offer of £5000. The artillery was exercised and defences were erected on all sides. Ladies and children made haste to leave by every train, but one lady of note, the Hon. Mrs. Rochfort Maguire, remained. The Commandant of Kimberley gave orders that trees should be felled and the bush cleared, in order to open a fine field for firing, the garrison to a man exerting themselves so as to give a warm reception to the enemy directly he should show a head above the kopje. On the 12th of October Mr. Cecil Rhodes arrived. His entry was somewhat melodramatic, as his train was delayed and spies were actually on the platform lying in wait for him. Fortunately he was not recognised. The magnetism of his presence added fresh zest to the proceedings in the town, while the calm confidence of his bearing became absolutely infectious. In fact, he soon delighted every one by stating that he considered Kimberley to be every bit "as safe as Piccadilly." At this time the town was well provisioned and the mines were kept working. Most of the garrison occupied the brigade grounds, while the detachment of regulars and the Kimberley regiments were stationed at the Sanatorium. The Town-Guard soon numbered 2000.

[Pg 66]

Skirmishing took place on Friday, the 14th of October, and on the following day there were more encounters. One squadron in an armoured train was held up by the Boers, and their attack was supported by a second force. The second squadron of the Protectorate regiment grandly repelled the attack. The train, in which were several Imperial officers, was uninjured. The Boer artillery gave way at last, and the forces withdrew, but not before having sustained heavy loss.

On the 15th a proclamation was made establishing martial law in Griqualand West and Bechuanaland. Persons not members of the defending forces were ordered to register their firearms, and no one was allowed to leave their houses between nine at night and six in the morning. The canteens without permits were opened only for a few hours during the day. Death was to be the punishment for acts contrary to civilised warfare. Fourteen Streams and Vryburg were now evacuated, the police detachments retiring from them on Kimberley.

In order to maintain internal order, Colonel Kekewich divided the town into four sub-districts, and the people were cautioned against holding communication with the Queen's enemies. The consumption of meat was regulated, each man being allowed 1 lb. daily, while the exports of foodstuffs and forage were prohibited. Roads were closed, and no one without authority or a permit was allowed to pass in or out. The defences everywhere were strengthened.

On the 21st of October, an armoured train that went out to reconnoitre discovered the enemy in the neighbourhood of Spyfontein. A proclamation having been issued by the Boers at Vryburg annexing Bechuanaland, most probably for the purpose of impressing the disloyal Dutch, Colonel Kekewich forthwith issued another, threatening that British subjects found assisting the Queen's enemies would be summarily dealt with as base rebels. He also declared that, in spite of the hoisting of the Vierkleur in Vryburg, the status of British subjects in Griqualand and Bechuanaland would remain unaltered. An armoured train was again engaged on this date, but only one man was killed. Two trucks of dynamite, however, which had been safely removed, were blown up by the Boers. The town was now completely isolated, the railway line being cut north and south.

[Pg 67]

On the 24th inst. the garrison, supported by two armoured trains, had a fresh and an exceedingly animated encounter with the enemy. Colonel Scott Turner and 270 mounted volunteers marched north to Macfarlane's Farm. There they off-saddled and kept a look-out for the Boers. Soon afterwards they appeared, and Colonel Turner opened fire. The Boers promptly intrenched

themselves behind a sandheap, and from thence kept up a hot fusilade. To Colonel Turner's assistance there came the Loyal North Lancashire Regiment, followed at noon by their Colonel—Colonel Murray—with two guns, two Maxims, and 70 mounted men.

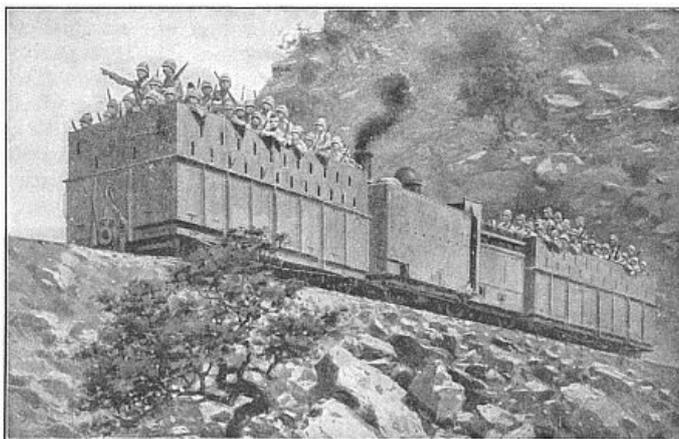

AN ARMOURD TRAIN

The Boers advanced on Colonel Murray and tried to cut off the party, and in endeavouring to frustrate their efforts Colonel Turner found himself in the thick of a furious fire which burst from a dam wall 500 yards on his left.

The British guns promptly began to blaze on the enemy, who very briskly responded. In the end, however, they were compelled to fall back. At this juncture the Lancashires, whose pluck and dexterity were magnificent throughout, hastily occupied the position, fixed bayonets, and gallantly drove off the enemy whenever he turned to make a stand. The fight, which was in every way a brilliant success, lasted four long hours. The British loss was three killed and twenty-one wounded, while that of the Boers was considerable. Commandant Botha was said to be among the killed. During this engagement Kimberley, as may be imagined, was in a state of frantic excitement, and the return of the troops was looked for by swarms of people, including women, who crowded the trenches and received the gallant defenders with great enthusiasm. Mr. Rhodes afterwards made an amusing speech to the Volunteers, complimented them on their splendid work, and explained that there was one man whom the Boers wished to capture, and that man was himself. Owing to the efficiency of the troops, however, he declared that he rejoiced in a sense of complete security. Cheers followed, for the Queen, the Governor, Mr. Rhodes, and the officers of the corps. After this things were fairly quiet, though the garrison remained on the alert. Lord Methuen, it became known, had started from the Orange River on the 22nd, and was daily decreasing the distance between his relieving force and the town; and, in order to meet his energetic advance, the Boers were unable to afford a sufficient number of troops to force the town into surrender. So Kimberley kept up its spirits—it viewed life with "one auspicious and one drooping eye"—mingling the discharge of guns with the chime of marriage-bells. This is no figure of speech, for there was actually a wedding—two people, at least, having found time to be romantic in their love amid the storm and stress of war. A dance and a concert also took place. Indeed, things were conducted with such high spirit and in so convivial a manner that it might have been imagined that the Boers were commissioned to supply the fireworks, and that a species of "Brock's benefit" was got up whenever events were inclined to wax monotonous. Reports computed the investing force at 4000, and it was further stated that General Cronje's commando would be reinforced by the arrival of some 1500 more. Yet the gallant little town smiled within itself and said "The more the merrier." Colonel Scott Turner made a reconnaissance on the 1st of November, found the enemy posted on a kopje, was thundered at with thirteen shells, but returned with his force in safety. On the 4th of November Commandant Wessels invited Colonel Kekewich to hand over the troops and town on pain of bombardment. The exact terms of the invitation are not known, but some portions of the communication were as follows:—

[Pg 68]

"In case your Honour should determine not to comply with this demand, I hereby request your Honour to allow all women and children to leave Kimberley, so that they may be placed out of danger, and for this purpose your Honour is granted time from noon on Saturday, November 4, 1899, to 6 A.M. on Monday, November 6, 1899. I further give notice that during that time I shall be ready to receive all Afrikaner families who wish to remove from Kimberley, and also to offer liberty to depart to all women and children of other nations desirous of leaving."

[Pg 69]

The Boers soon began to receive the reinforcements which have been mentioned. These came from the direction of Mafeking, that place having proved too much a "spitfire" for their liking. As a last resource, they directed their attention to Kimberley, and by way of exercise blew up some £3000 worth of dynamite which was stored in some huts belonging to the De Beers Company. While these exciting events were taking place, and with the roar of intermittent explosions in his ears, Mr. Rhodes pursued a placid way. His labours were eminently horticultural—at least so they appeared on the surface. He engaged himself at Kenilworth, the suburb which he may be said to have created, in planting an avenue a mile long with orange-trees, espalier vines, and pepper-trees. It was called his Siege Avenue. There was suggestion in the arrangement, and the mind instinctively conjured up visions of mystery—mystery somewhat prolonged and clinging, with spice of a stimulating kind thrown in.

News from the Orange River, which came in by fits and starts, hinted that after the evacuation of Colesberg would come the abandonment of Stormberg. Stormberg was intended to be the depôt where stores, tents, ammunition, and all the commissariat details of the Third Division under General Gatacre would be accumulated. These stores, owing to the Boer advance from Bethulie and Aliwal North, were now being removed to Queenstown, some sixty miles down the line.

[Pg 70]

CHAPTER III

NATAL

In consequence of the incursion of about 3000 refugees—some of them most undesirable in character—it was deemed expedient to issue a proclamation of martial law in Natal. This was followed by the seizure of the Transvaal National Bank at Durban, a most exciting episode, which caused quite a ferment in the town. All around the offices a curious and somewhat rowdy rabble congregated, and it was found necessary to guard the premises with Bluejackets and marines. However, after the place had been searched, the men, looking strangely transmogrified in their kharki, returned to Her Majesty's ship *Tartar*, and affairs went on as usual. At the Cape, owing to widespread rumours of disloyalty, Sir Alfred Milner issued the following proclamation, dated October 28:—

"Whereas it has been reported to me that a proclamation has been made by or on behalf of the Government of the South African Republic purporting to declare as part of the territory of the Republic certain portions of that part of this Colony situated north of the Orange River, and which have been invaded by the forces of the said Government; and whereas it is necessary to warn all Her Majesty's subjects, especially those resident in the aforesaid portions of this Colony, of the invalidity of such proclamation:

"Now therefore, in virtue of the authority committed to me as Governor of this Colony, I do hereby proclaim and make known that any such proclamation, if made, is null and void and of no effect, and I do hereby further warn and admonish all Her Majesty's subjects, especially those resident in the aforesaid portions of this Colony, that they do, in accordance with their duty and allegiance, disregard such proclamation, as being of no force and effect whatsoever, and observe their obligations to her Majesty, her Crown and Government, and in no way voluntarily accept or recognise the Government of the South African Republic in any part of this Colony which may have been proclaimed territory of that Republic.

"And I do further warn that any one failing, in contravention of the law, to obey the terms of this proclamation, will render himself liable to be prosecuted for the crime of high treason."

To Mr. Chamberlain he wrote on the subject on the same date:—

"It is impossible accurately to find out what has happened as regards the alleged annexation by the Government of the South African Republic or Orange Free State of portions of the Cape Colony.

"No copies of any proclamation by either Government to that effect have reached me here, but news coming from various parts of districts west and north of Kimberley clearly show that the people there credit the annexation theory.

"It seems, however, more probable on the whole that it is the Government of the South African Republic which has annexed the district north of the Vaal River.

"With the consent of Ministers, I issued yesterday the proclamation contained in my previous message, in order to check the mischief which this widespread report is causing."

Apropos of Sir Alfred Milner's letter, it must be mentioned that several of the Bechuanaland Dutch had openly joined the Boers; and on the occasion of the hoisting of the Transvaal flag in Vryburg, Commandant Delarey took occasion to deliver himself of an effective speech, in which he said that the flag of the country was now floating over the whole Orange River, and that the flag of Britain would never again do so unless it were hoisted over the dead bodies of the Burghers. At Klipdam also the Boers put in an appearance, and celebrated their incursion by holding "at homes" in the Magistrates' Court; but hearing of the British successes at Kimberley, and judging discretion to be the better part of valour, they decamped northwards, leaving food and stores behind.

The disaffection of the Dutch was as yet almost confined to the western border. On the eastern side the inhabitants for the most part were staunch. Indeed, in the history of the war the splendid loyalty of Natal as a whole will ever be remembered. Her trials were many and her faith almost sublime. Weekly the *Times of Natal* had poured forth its plaint on the dilatoriness or insouciance of the Imperial Government, yet nothing was done till those who put their trust in the good faith of the mother country were deprived of home and fortune, and in their bitterness were tempted to declare that British protection was as Dead-Sea fruit—a profitless show, that was apt to turn to ashes in the mouth. The following letters serve to show the attitude of a staunch loyalist under the severe strain put upon him, and they are quoted because they are descriptive, not of individual anxiety and distress, but of the general feeling of the Colony in those months of supreme trial.

One letter, dated October 27, began:—

"Those brave fellows up at Ladysmith have been fighting all day. We heard their cannon even after

[Pg 71]

dusk. What is the result, I wonder? I fear we shall not hear till to-morrow. That essential but most aggravating censor causes such delays, and dishes up such garbled accounts of the actual facts, as to astound those who know the truth.... There is little chance of our being able to attempt even to defend this place. It simply means evacuation or surrender, and stand by and see the Transvaal flag go up! O England! England! As ever, unprepared."

The next letter, dated October 31, said:—

[Pg 72]

"Here we are in peace and quiet, such as it is possible to enjoy with the roar of artillery booming over the few miles of echoing hills which divide us from the scene of battle and bloodshed, torn limbs and ceaseless pain. I am weary of the contemplation of all this frightful suffering and brutality.... I do not know what opportunities you have of obtaining correct information, for the trash the papers publish after the real facts have been distorted by the censor is as good as useless. I hardly like to say too much, as one never knows into whose hands one's letters may fall, and our own noble defenders are as severe in suppressing the knowledge of the true facts of the battles and movements of the forces as any enemy could possibly be. However, the game is with the English still.... If only Ladysmith is held, the Colony is safe. This shocking flight of women and children from town after town is too awful to witness. Shame on the British Government to make our Colony the scene of this bloody struggle, and leave the handful of soldiers sent out all unsupported, unprepared—unprepared as usual—all smug and self-confident in the little overcrowded, over-comfortable island, and forgetful of the horrors to which unfortunate colonists are exposed across the sea."

The Governor of the British prison at Misina, Pomeroy, Natal, wrote in a similar heart-breaking strain:—

"I have only time for a few lines. I am tired out, having been turned out of house and home by the cursed Boers. I have ridden the ninety-one miles to Pietermaritzburg. I and four other Government officials had to remain at our posts till the last. We had to ride for our lives. I never shall forget these times. We waited almost too long—long enough for the five of us to have a shot at the advanced guard, of whom we captured two, and rode with them to the Volunteer camp, eighteen miles from Pomeroy, at Tugela. I never felt like shooting any one before a commando of about 400 came down for myself and the magistrate."

In regard to the readiness of Natal to support British supremacy, a visitor who participated in the raising of the volunteer regiments there stated that there were 4500 volunteers in the field, three-fourths of whom were drilled men. They were enrolled at the rate of 200 a day. Durban a month later raised a splendid corps of colonial scouts for the purpose of checking Boer raiding. It was composed of some sixty or seventy men of the best families in the place.

The conduct of the Natal women was especially noteworthy. Their patience, their fortitude, their eager desire to be of service, their readiness to face sacrifice, won general esteem. One eye-witness stated that while shells were hurtling through the air and bursting on the ground, they—the women-folk of the place—calmly traversed the streets in ordinary costume and with ordinary demeanour, as though no hostile Boer or bellowing gun was within a hundred miles of them. Not a trace of fear or panic was manifest. It was not surprising to learn that a community boasting such noble specimens of womanhood decided to remain where they were rather than accept the dubious shelter offered them by the Boer general.

[Pg 73]

Mr. Winston Spencer Churchill, writing of the Natalians in the *Morning Post*, feelingly said: "There are several points to be remembered in this connection. Firstly, the colonists have had many dealings with the Boers. They knew their strength; they feared their animosity. But they have never for one moment lost sight of their obligations as a British colony. Their loyalty has been splendid. From the very first they warned the Imperial Government that their territories would be invaded. Throughout the course of the long negotiations they knew that if war should come, on them would fall the first fury of the storm. Nevertheless, they courageously supported and acclaimed the action of the Ministry. Now at last there is war—bitter war. It means a good deal to all of us, but more than to any it comes home to the Natalian. He is invaded; his cattle have been seized by the Boer; his towns are shelled or captured; the most powerful force on which he relies for protection is isolated in Ladysmith; his capital is being loopholed and intrenched; Newcastle has been abandoned, Colenso has fallen, Estcourt is threatened; the possibility that the whole province will be overrun stares him in the face. From the beginning he asked for protection. From the beginning he was promised complete protection; but scarcely a word of complaint is heard. The townfolk are calm and orderly, the Press dignified and sober. The men capable of bearing arms have responded nobly. Boys of sixteen march with men of fifty to war—to no light, easy war. The Imperial Light Infantry is eagerly filled. The Imperial Light Horse can find no more vacancies, not even for those who will serve without pay. The Volunteers and Town-Guards bear their parts like men." Of the excellence of the service of the Natalians a great deal remains to be said. At present the story must proceed.

The arrival of Sir Redvers Buller at Cape Town on the 31st of October was a signal for general rejoicing. The streets were filled to overflowing, and cheer after cheer rung from thousands of throats. As the General drove to Government House, he was greeted by cries of "Avenge Majuba!" and "Bravo, General!" and by the amount of emotion expended and the universal expression of relief evidenced, it was plain that the Cape colonists, like the cockney Londoner, were prepared "to bet their bottom dollar" on the combination of Sir Redvers Buller and Mr. Thomas Atkins!

On the 2nd November the Boers proclaimed the Upper Tugela division of Natal to be Free State Territory, and they seized Colesberg Bridge, some eighteen miles north of the town of Colesberg, where the road between that place and Philippolis crosses the Orange River. However, as Orange River, De Aar, Colesberg, and Stromberg were still held by our forces, the inhabitants remained

It was a curious fact that some of the Boers started from Johannesburg for the frontier wearing in their hats the national colours, red, white, and blue—and green, with above them a yellow band, thus completing the insignia of the United South Africa for which they were to fight. It would be interesting to know how the red, white, and blue became associated with the green, and whether Aylward, the agitator, and his Fenian friends introduced it for the purpose of giving prominence to the sympathy of the Anti-English brotherhood in the Emerald Isle. The disloyal Natal Dutch, such of them as there then were, were distinguished by a red rose badge. These signs were of no consequence in themselves, but they served to demonstrate the preconcerted nature of Boer actions, which were supposed by certain persons to have been a sudden and spontaneous outcome of British oppression.

Racial feeling grew stronger and fiercer day by day, and Mr. Kruger's threat to "stagger humanity" was by some declared to be within an ace of being fulfilled. The Boer is inherently as tough as the Briton, and as obstinate: he was now well equipped for warfare, well led, and the chances of a terrific and bloody struggle seemed hourly to become more and more certain. Fortunately, each day brought our troops nearer to the Cape, and after the 9th of November they began to disembark—a total, so far, of 11,000 in all. At first sight this military multitude seemed an imposing addition to our force, but, in view of the losses we had sustained and the general complications of the position, some 100,000 was nearer the figure required. However, the Home authorities chose to send out their help in dribblets, and the same Home authorities were supposed to know how the dribblets might be adequately disposed. It was only to the ignorant "man in the street" that the problem of how to meet the massed armies of the Boers with diffused handfuls of troops became incomprehensible.

Among the misfortunes with which the British had to contend was the unfit state of the horses after prolonged travel. Horses are intensely liable to sea-sickness; they also suffer much from being cribbed, cabined, and confined for any length of time; and the difference between the state of the Australian and the British animals on landing was very marked. The former were in good working fettle, while the latter had swollen and stiff joints, and were generally below par. The New Zealand chargers were all that could be desired, and they made an excellent show when compared with those of some of the other mounted regiments. Horse-sickness had also to be contended with, and it was with great difficulty averted. Some of the officers, however, discovered that by keeping the horses protected by their nosebags during the dewy hours of early morning the liability to the complaint was lessened. The question of horses was a serious one, almost as important as the question of guns. The exceeding mobility of the Boer army for long had been a matter of surprise, if not to the initiated, at least to the general public, and, as it later appeared, to the Government itself. They had sent out important generals and learned tacticians, and a fairly large and unwieldy mass of men, who were bound by their healthy appetites to stick to their base and hug the railway lines, while the enemy shifted about with the most annoying and confounding velocity, delighting to deceive as to their position, and in their deception being for the most part eminently successful. There is a passage in the Scriptures that mentions that "the king of Israel is come out to seek a flea as when one doth hunt a partridge in the mountain," and this quotation on the approach of our weighty military machine, the Boers, ever Biblical, must have been inclined to remember and to appreciate.

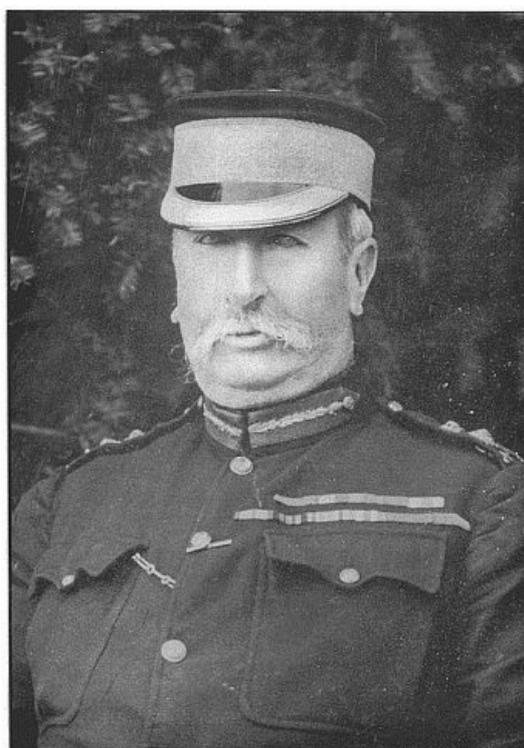

Rt. Hon. SIR REDVERS HENRY

The opinion seemed prevalent, particularly in Colonial circles, that English generals, in consequence of their European or Indian experiences, were unequal to a struggle with the "slim" and shifty Boers. Laing's Nek, Ingogo, and Majuba had all proved that some extraordinary weakness, either tactically or mentally, seemed to possess the bravest warriors in the face of this incomprehensible foe. Since the date of Majuba the ways of the Boers had become still more of a conundrum. They had kept up their habit of sharpshooting, and had acquired an insight into German tactics. For all that, on occasion certain of their old commanders resorted to the primitive tricks of the Zulus, and advanced in horn fashion, keeping one horn in ambush as long as possible, so as to create a surprise for an unprepared enemy. Even to eminent tacticians like General Clery and others, the blend of modern German and antique Zulu in the ordering of war must have been confounding, and it is scarcely surprising that they took some little time to master the subject.

The landing, on the 8th November, of the Naval Brigade with twenty guns for the defence of Durban was a move in the right direction, and the arrival and marching in of the brigade was an inspiring sight. The streets swarmed with an enthusiastic multitude that welcomed the jolly Jack Tar with delight, and cheered itself hoarse, almost drowning the vigorous strains of the band of the *Terrible*, which played outside the Town-Hall. Captain Percy Scott of the *Terrible*, inventor of the now celebrated gun-carriages, replaced Major Bethune as commandant of the forces defending the port, while the latter officer returned to the active command of the Uitlander corps.

The tide of reinforcement now began to flow evenly into Cape Colony and Natal, and there was great excitement owing to the arrival of the *Moor*, which left Southampton on October the 21st. Among those on board were Lieutenant-General Lord Methuen, commanding the First Division of the Field Force; Major-General Sir C. F. Clery, commanding the Second Division; and Major-General Sir W. F. Gatacre, commanding the Third Division; and a large number of officers for service on the Staff.

[Pg 76]

THE INVASION OF CAPE COLONY

The position of affairs in the direction of the Orange River was at first somewhat stationary. The British were awaiting the arrival of troops and keeping on the alert; the Boers were making proclamations and annexing adjacent villages.

A column from Cape Colony had started, and more troops were pushing up as fast as train could carry them in the direction of De Aar. A letter from a British officer from that place describes the state of affairs on the 20th of October. He said:—

"This place is to be a big base when the British troops arrive; 10,000 are to come here, but are not expected for at least a month. At present we are the only regiment here, and have to keep the line open and guard all the stores coming up for the 10,000 troops. We have not got half enough men, as the front of our position is nearly five miles, and we cannot watch it properly. Our position is strong as long as we can hold the hills; but if the Boers can get artillery near us, they will wipe us out in a few hours without getting within rifle range at all, as we have no guns ourselves. We keep on telegraphing for them, but the officials at home and at Cape Town do not seem to understand the position. The worst of this place is that there is not a loyal native within twenty miles of us, and they are only waiting for a good opportunity to rise. We can only be ready for them—that is, we cannot attack them, as they have not yet declared openly for the Transvaal, though they are all spies, and give the Boers information on all our dispositions."

In this short letter we find the keynote of all our subsequent troubles. The complete and almost absurd confidence of the British, supported as it was by valour without wisdom or activity, was a "voice" and nothing more. Deeply have we suffered since those words were written, for an arrogant under-estimation of the enemy, a reprehensible delay in preparing for him, and a parsimonious system of carrying out those preparations when attempted. However, it is useless to cry over spilt milk.

To thoroughly appreciate the situation at this period it is necessary to understand the direction in which our troops were moving. Modder River, Hope Town, and Orange River are situated on the railway between Kimberley and the junction of the lines which run south to Cape Town and Port Elizabeth respectively. De Aar, of which we began to hear so much, is an important station at the apex of the triangle, just over 500 miles from Cape Town, and here towards the end of the month of October many troops were congregating. Here, though no hostilities were actually taking place, there was a good deal of simmering activity; for it must be remembered that De Aar Junction was our advanced supply base in the Colony, and owed its strategical importance at this critical period to the fact that it was the junction of Cape Town and Port Elizabeth railways. It is situated about sixty miles from the Orange River and Free State border.

[Pg 77]

The contrast at this time between camps British and camps Dutch in the neighbourhood of the border was curious. The Boers were prepared, taking their ease. The British were in suspense. Disaffection was visible on all sides, and yet inaction, irritating inaction, was obligatory. Morning, noon, and night a perennial sand-storm blew; overhead, the sun grilled and scorched. Meals,

edibles, and liquids were diluted with 10 per cent. of grit, and when perchance Tommy strove to strain his hardly-earned beer—to make a filter of a butter-cloth—phut! would come a gust of wind and bring the experiment to a melancholy conclusion. Poor Thomas's temper was much tried! He was, of necessity, an exceedingly temperate fellow in those days, but when he got a pot of beer he preferred it to be beer, and not porridge. He did not relish in his mouth the same thing that the wind was distributing impartially into ears and eyes. He said he could take in—at the pores—enough of that to suit his liking. But he was no grumbler, as a rule. He worked hard and incessantly, Colonel Barter determining to keep his men of the Yorkshire Light Infantry quite up to the mark. It was necessary to take every precaution against surprise, and for commanding officers to remain eternally on the *qui vive*. It needed considerable tact to order sufficient work, and only sufficient. It was dangerous to over-fatigue troops who might be required to leap to arms at any moment; it was also risky to allow active men in a hot sun to give way to inertia. There was the never-ceasing routine of guards and picquets, the practice of route marching and field manoeuvres, and the daily round of minor camp duties to keep the warriors hale and hearty, and prepare their thews for a tough tussle. A regular system of scouting was matutinally carried on, and it was thought that the enemy would not be able to encroach beyond his border without enjoying a startling reception. At this time he was not visible, and all that scouts could detect, beside some innocent hares and springbok among the hills, was now and then a flying horseman who disappeared on their approach.

[Pg 78]

But the Boers were not far off. They were encamped close to the border. One adventurous individual, for his personal satisfaction, performed the feat of travelling north and swimming across the Orange River to reconnoitre. In the darkness of the night he stole out, plunged cautiously into the river, clothes and all, and swam safely to the other side. Then striking out in a north-easterly direction, he made for a small kopje overlooking the Boer camp. Meanwhile the moon had sailed out, and began to throw a sheet of silver over the panorama. Below, the three lines of tents were outlined, and these were flanked and interspersed with multitudinous waggons, which formed a chain almost along the entire length of the valley. In the early dawn more objects became discernible, the flickering red tongues of the camp-fires, the winking eye of a lantern that hung from a pole. By this illumination it was possible to note the general scene of disorder. Scattered garments and goods in promiscuous array—ammunition and provisions, harness, saddles, biltong, and gin-bottles—a multifarious, slovenly litter, shed here, there, and everywhere. Only two sentries were visible, and these our friend stealthily evaded. One Cerberus sat on the ground with his back planted against a waggon wheel yawning dolefully, and farther on slouched another, hands in pockets, head on chest, walking back and forwards with the air of an automaton. The individual creeping past them, close under their noses, smiled softly to himself. How simple to sweep off a dozen or two of the inmates of the camp before these so-called sentries recovered from their dozing. Fifty men and fifty bayonets could have got in without difficulty, and the rout of the rebels would have been an affair of moments. Now, perhaps before nightfall the whole commando would have melted away!

Presently at the bottom of the kopje came horsemen—some five of them—galloping along, and the adventurous one made haste to hide. The Boer patrol passed within some two hundred yards of him, and he was safe. It was now time to hurry off. The day was breaking. Again a plunge into the icy river, again a fight with the racing current, again a safe landing, this time on the British bank. So the escapade ended, but it enabled those interested to form a fair idea of the lack of organisation among the Dutch, and to argue that if once they should leave their naturally strong fortifications and intrenchments, the first united and sustained attack on the part of the British would mean their certain discomfiture.

At the end of October the Border Regiment arrived upon the scene. The Yorks almost immediately struck camp and prepared to entrain for Orange River; but presently a counter-order arrived, and, much to their regret, the regiment again resumed its former routine.

The place at this time was under military law, and precautions were rigorously taken against spies. The railway stations were cautiously guarded night and day, and none was allowed to approach without proper authority. Troops soon began to pour through on the way to Orange River, whence the advance was shortly to take place. Tremendous labour came on the hands of Lieut.-General Sir F. Forestier Walker, who took trips along the lines of communication to ascertain that all arrangements were satisfactory.

[Pg 79]

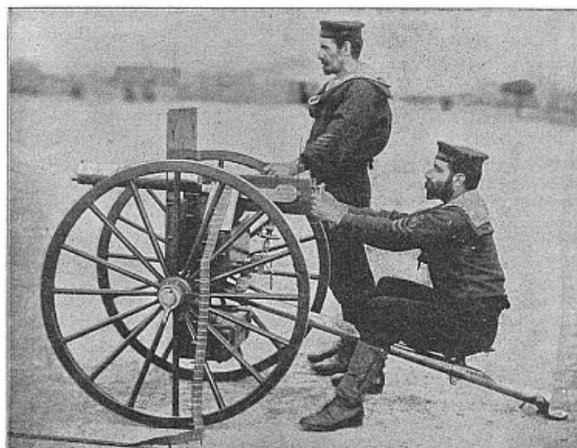

In readiness for the influx of troops new sidings were constructed to north and south of the railway station, and the little karoo junction began to assume an air of wonderful importance. Among the innovations was a branch of the Standard Bank adjoining Friedlater's Store, showing that, though not a Klondyke, this place, which has been described as "the windiest, dustiest, most unfinished, most inhospitable corner of the South African wilderness, the veritable jumping-off place of the globe," was fast becoming the base of gigantic military operations. The outlying farms were still in occupation, though inhabitants were few. These apparently were indifferent to the progress of coming events, but possibly at that time they were engaged in careful investigation as to the side of the bread which held the most butter before committing themselves to an attitude. Their sole obvious desire was that patrols should not omit to close the gates after them whenever they chanced to pass through their domains. The Border Regiment soon after its arrival moved to Naauwpoort, and a battery and a half of artillery swelled the little garrison. The development of the place now went on more rapidly.

[Pg 80]

Mr. E. F. Knight, the brilliant correspondent of the *Morning Post*, wrote an interesting description of this now important locality only a few days before he had the misfortune to lose his arm through the treachery of the Boers. He said:—

"The township, which surrounds the railway station, is merely a congregation of a few houses belonging to people connected with the railway. It stands in the midst of a desert—a dusty, treeless plain covered with sparse low sage brush and enclosed by rocky ridges. The camp is ever increasing in size, but, as I write, it consists of two encampments, one to the north and one to the south of the township, all the troops being under canvas. In the North Camp are the 2nd Battalion of the King's Own Yorkshire Light Infantry, eight hundred strong, and a field-battery and a half-battery (15-pounders), and in the South Camp, in which I have pitched my tent, is the remount camp, with a company of the Army Service Corps, a supply detachment of the same corps, with a field-bakery, two half-sections of the Royal Engineers, a company of the Army Ordnance Corps, and a detachment of the Volunteer Medical Staff Corps. A wing of the Berkshire Regiment has also just come in from Naauwpoort, which we have abandoned as being untenable by the small force which could at present be spared to defend it. There are at De Aar now about two thousand men all told, including Major Rimington's two hundred scouts. More artillery is expected from Cape Town, and by the time this letter reaches England we shall probably be largely reinforced. Several redoubts, lines of intrenchments, and sangars on the heights protect the camps, and a few small guns have been posted on the neighbouring kopjes. The surrounding country is being well patrolled, and we cannot well be taken by surprise.... In short, one sees here all that skilled, laborious, indispensable preparation for the campaign of which the British public knows so little, and which never receives its due credit at home.

"It is wonderful, indeed, that the Boers did not attempt to seize this valuable prize a week or so ago, when the camp was practically undefended, and when our officers, momentarily expecting attack, were sleeping in their boots. Our position is far from secure even now; our force here is insignificant, and it seems that the Boers are getting nearer. They have crossed the river at various points.

"Our scouts have been in touch with their commandoes. We have had some false alarms since I have been here; it is rumoured to-day that they are close to, and that the attack on De Aar is but a question of hours. But still the heavily-laden trains come in with their valuable freight and the military stores accumulate. It is to be hoped that we shall have the men, too, without delay."



SERGEANT OF THE KING'S ROYAL RIFLES.

Photo by Gregory & Co., London.

In the above words we have, repeated, the story of suspense and anxiety that was told by one and all who had the misfortune to spend October and November on the Transvaal border, a story of brave Britons, practically unarmed—heroically valorous but impotent—standing almost in the teeth of the enemy and sickening with hope deferred.

[Pg 81]

The Dutchmen came to work much fresher. The warrior-farmer was untrammelled by red tape—unwearied by routine. He was not hampered by minute regulations, though he was bound to look after himself and rely on his own resources. He provided his own provisions, his own waggon and horses, but the Government in the event of his requiring it supplied him with the necessaries of the campaign. He could have luxuries *ad libitum* sent from home, and while battle was not absolutely going on he had little to do but to eat, drink, and sleep. Drills and field exercises were unknown, though, of course, each had to take his turn at guard duty. In action the operations of the Boer commandoes were presided over by field-cornets, and in camp the work was carried out by corporals, who superintended the supply department—the munitions of "war" and "mouth," as we call them, on which the fighting line depended for ammunition and food.

General Wood arrived at De Aar on the 4th of November and took over the command of the troops. His first action was to employ the Engineers and some Cape boys to throw up defensive works and erect sangars on a ridge—some 2000 yards from the camp—which by a sheer accident had not been seized by the Boers. From this point of vantage it was possible for the British guns to command the plain for many miles round. He then put the place under martial law, as Dutchmen and spies were slinking about in the neighbourhood of the railway and the camps. The General's regulations ran thus:—

"No person is allowed to remain in or to quit De Aar without a permit signed by the Magistrate, and countersigned by the Camp Commandant. The permits for railway officials will be signed and issued by the heads of the traffic, locomotive, and engineering departments, those for postal officials by the heads of that department. Any person found selling intoxicating liquors to a soldier or to a native or coloured person will be immediately apprehended and the whole of his goods will be seized. The sale of intoxicating liquors to others can only take place between the hours of 11 A.M. and 6 P.M. This includes sale of liquors to persons staying in any hotel or boarding-house in De Aar. Every person keeping an hotel or boarding-house, or any one receiving persons into his private house to stay for one night or more, is required to obtain permission of the Camp Commandant before doing so. No persons other than railway and postal officials, who will be provided with a special pass, will be allowed to be out of their houses after 9.30 P.M. Any person infringing these regulations will be dealt with by martial law."

We must now move in the direction of the Orange River, where more activities were taking place. Information having been received that the Boers in great numbers were gathered at Kaffir's Kop, a hill some 500 feet high east of Belmont, a reconnaissance was made in that direction on the 10th of November. The reconnoitring force was composed of a couple of squadrons of the 9th Lancers and detachments of the Munster Fusiliers, the Northumberland Fusiliers, and the Loyal North Lancashires. With these were a handy lot of mounted infantry and a half battery of field-artillery. They bivouacked two nights before on the north side of the bridge, in order to be ready to move on at daybreak. Early on Thursday morning they marched out, the cavalry forming a wide screen, behind which were the mounted infantry and guns. Belmont, which was some twenty-eight miles off, was reached at 2.30, but not a sign of the Dutchmen was to be seen. The troops consequently returned to Fincham's Farm, some ten miles back, where they spent the night. In the morning they went east, where the enemy was reported to have retired. The object of the reconnaissance was to ascertain the strength of the enemy, and this was soon achieved, for he was found to be in immense force in a position of natural strength flanked by huge hills. Some smart skirmishing ensued. Colonel Gough with a battery of field artillery engaged the Boers and sent one and a half companies of mounted infantry to turn the enemy's left flank and discover his laager. Fighting continued for more than three hours, during which Colonel Keith-Falconer,^[5] Northumberland Fusiliers, was killed. Lieutenant Wood, North Lancashire Regiment, was shot through the head, and Lieutenants Bevan and Hall of the Northumberland Fusiliers were also wounded. An armoured train came to the rescue and attracted the Boer fire, pouring from two Maxims a withering storm of bullets on the enemy and inflicting heavy loss. The Dutchmen were discovered to be in great force all around, and as they blocked the road to Kimberley, the promise of more spirited engagements was in the air. Already it was ascertained that a number of culverts on the railway line had been destroyed by the hostile troops, and rumours of Boer invasion were continually being brought in.

[Pg 82]

The next day, amid universal regret, the two gallant officers who had lost their lives in leading their men against the powerful enemy, were buried.

Lieutenant Brook (9th Lancers) on the day of the reconnaissance had a narrow escape, and experiences more exciting than pleasurable. Early in the morning he had gone on ahead of the column for the purpose of making a route sketch. This done, he sent it back by his orderly, and while continuing his investigations found himself confronted with the enemy. A shower of bullets greeted him. His horse was shot and he was brought to the ground. It was neck or nothing now, and he ran for dear life pursued by a horde of mounted Boers. Fortunately he came to a wire fence, vaulted it, and was for a moment safe. The enemy's ponies could not follow. But the Boers sent shots after his retreating form, shots which luckily missed him, and he was enabled to reach

[Pg 83]

two troops of the 9th Lancers which galloped up to the rescue.

On the 12th Lord Methuen arrived, and there was general satisfaction among the troops. They were now in fine fighting condition, and, having had one taste of battle, were longing to advance and get in touch with the enemy.

But the advance of Lord Methuen's column was no simple affair. It must be remembered that from Cape Town to the base, De Aar, is 500 miles, to Belmont 591, to Kimberley 647, and to Mafeking 870 miles, and the railway from place to place needed continual guarding, and especially the bridges in localities where the disaffected portion of the Dutch community resided. Lord Methuen's route, too, lay across a species of dusty Sahara, over boulder-strewn plains with scarcely a tree to offer shade, though dotted about now and then with some ancient kopjes to vary the monotony of the South African scene. On these kopjes it was as likely as not that Boer sharpshooters might already be hidden, for the affluent Dutchmen forced their poorer countrymen to maintain eyrie-like positions—padded with blankets and hedged in with boulders—in readiness for the approach of an army, while they themselves arrived fresh, spick and span, only on the rumour of battle.

With all its alarms, however, life in camp was not without its joviality. The Naval Brigade prepared for action laughing and singing, and Jack Tar indulged in promiscuous hornpipes between the conversations of his big guns. A correspondent of the Central News Agency gave an entertaining account of his sojourn among the military. He said:—

"There are, of course, pleasantries and pleasantries. The other night a correspondent was returning to camp when he was met with the usual challenge. 'Who goes there?' shrieked the sentry. 'A friend,' replied the correspondent. 'Stand, friend, and give the countersign,' promptly demanded the watchful guardian of the camp. The correspondent had forgotten the countersign. He knew it related to Yarmouth. As a matter of fact, it was Yarmouth. So he made a desperate bid for bed, and replied 'Bloaters.' The sentry replied, 'Advance, friend,' and the scene closed. You doubt this as *ben trovato*. Well, do not doubt any longer when I plead conviction in personal guilt. I was 'Bloaters.' Nevertheless, to an active sentrydom, as well as to vigilant curfew, we were becoming cheerfully accustomed. It is martial law, and the camp is the centre of Boerdom. Anything, indeed, is welcome, even martial law, if it relieves boredom at the same time."

[Pg 84]

On the 14th of November General Wauchope, commanding the Highland Brigade, arrived on the Orange River, followed a day or two later by Major-General Sir H. Colvile, who assumed command of the Guards Brigade and camp north of the river. The First Division was composed of two brigades. The Ninth was an Infantry Brigade, consisting of portions of the Northumberland Fusiliers, a wing of the North Lancashires, portions of the Manchesters, the Yorkshires, and the Northamptonshire Regiment. The Guards Brigade was composed of the Scots Guards, two battalions of the Coldstreams, and one of the Grenadiers. To this brigade was attached the Naval Brigade (Captain Prothero, H.M.S. *Doris*). There were also two squadrons of the 9th Lancers, "bits" of the Engineers, of the A.S.C. and the Army Medical Corps—the whole force numbering some 9000 men. The transport arrangements having been completed, the advance was to be made in the course of the week. Officers and men were to wear uniform as similar as possible, in order not to give the sharpshooters a chance of distinguishing them. The men covered their buttons with mud and sand in order to make them more of a piece with their kharki, and their haversacks in the same way were darkened to match.

At this time Naauwpoort and Stormberg were evacuated by order of Sir Redvers Buller, on the ground that our frontier line was weak and too much extended. The troops from the former place reinforced De Aar, those from the latter strengthened Queenstown. The enemy, though he left De Aar in peace, was active elsewhere. A Boer commando of 1300 to 2000 strong entered Colesberg on the 15th November before dawn, and planted itself on the kopjes surrounding the town, much to the surprise of the inhabitants. The invaders possessed themselves of the keys of the town, and endeavoured with great parade to hoist the Free State flag. The ceremony was a fiasco, however, as before the flag reached the top of the staff, the halyard, which had been secretly cut partly through by some loyalists, broke, so that the flag, flying a little above half-mast, could neither be hoisted properly nor hauled down again. Ultimately the Boers tied another flag on to the end of a long bamboo, and sent that up instead. The Mayor endeavoured, in impassioned periods, to address the loyal inhabitants, but his eloquence was useless. He could not make himself heard, and had at last to desist.

[Pg 85]

The Mounted Police, who were forced to retreat from Colesberg, joined the New South Wales Lancers at Naauwpoort, and from thence went on to De Aar. Aliwal North was occupied by a Free State commando, and the inhabitants of Lady Grey were ordered to vacate the place. They were allowed until the 25th November to obey orders. The public offices there were closed, and preparations were made to occupy the town.

Here must be noted the story of a woman in a thousand—the post-mistress of Ladygrey. When the Boers came to seize the post-office, she "stuck to her post" with a vengeance. She refused to budge or to give it up, and when the Free State flag was hoisted, she promptly hauled it down and substituted the Union Jack. Not content with this, she tore down the proclamation of the Boers annexing the district, and put in its place the Governor's proclamation against treason. Pluck carried the day; the Boers were worsted, and the post-mistress remained mistress of the situation. What became of this heroine of the war is not yet known.

Proclamations emanating from Bloemfontein, and signed by Mr. Wessels, President of the

Volkraad, were also issued, declaring the whole of Griqualand West, except Kimberley and Mafeking and the districts four miles around each of these places, to be Free State territory. In the face of these energetic movements action on the part of the British was necessary to restore the confidence of the wavering people, and consequently the following telegram was despatched by the General Commanding in Chief to the officer commanding at Queenstown:—

"November 15.—General Gatacre, with the 1st Battalion of the Seventh Brigade, left yesterday for East London. More troops will follow as they arrive.

"Owing to the distance from England, it has not been possible to give the frontier districts, at first, the protection they merit, and the enemy's troops have in places entered our territory.

"Make known as widely as possible that her Majesty's Government will exact compensation for any actual injury done to the property of individuals who remain loyal, and take every means in your power to obtain and record the names of any who may act disloyally, with a view to the consideration of their cases afterwards. Circulate this as widely as you can in English and Dutch."

On the other side the enemy exerted himself freely. A curious appeal was made to the farmers about Colesberg by the Boer commander. He addressed the crowd with great fervour, and called on all to join the Republican cause and to throw off the yoke of England, whose tyranny could no longer be endured. War, he declared, had been forced upon them. They were now fighting for liberty, and it was the will of God. He said it depended on the Afrikaners themselves whether they would for ever continue to be ruled from Downing Street or become an independent nation. So far, he added, their arms had been victorious, and God had been with them.

[Pg 86]

Meanwhile Lord Methuen and his troops were preparing to march to the relief of Kimberley *via* Witteputs, and in expectation of his arrival (of which they were duly informed by their many spies and the disloyal Dutch in the neighbourhood), the Boers, reinforced, posted a cannon at Belmont Station, and again took up a powerful position on the Kaffir's Kop range of hills.

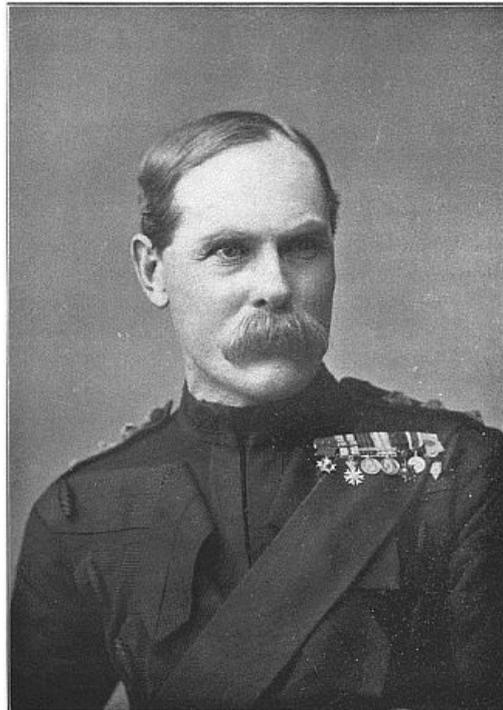

**LIEUT.-GENERAL LORD METHUEN,
C.B.**

Photo by Elliott & Fry, London.

THE BATTLE OF BELMONT

On the morning of Tuesday, the 21st of November, at three o'clock, Lord Methuen's march to the relief of Kimberley definitely began. The force consisted of the Naval Brigade, the 9th Brigade under Colonel Featherstonhaugh, the Guards Brigade under General Sir H. Colvile, two batteries of Field Artillery, Rimington's Guides, and the 9th Lancers. The first halt was made at Fincham's Farm, some twelve miles off, where the troops breakfasted, and whence the 9th Lancers and Rimington's Guides started on a reconnoitring expedition, which was not without its excitement. The Boers were reported to be somewhere in the vicinity, and soon they were espied, some three hundred of them, climbing a kopje with the evident intention of firing down on the party. This they did, and with such rapidity that only by sheer luck the men escaped. They went on to the farm of one Thomas, a supposed loyalist, for the purpose of watering their horses. This person had declared that there were no Boers in the neighbourhood; but no sooner had the tired beasts begun to dip their dusty noses in the cool and longed-for draught than a brisk fire was opened on them from all sides, and the troops had hurriedly to return to the main body at Fincham's. But

they lost three horses.

On the following day the division moved on to the said Thomas's Farm. The advance party again came under fire—"Just by way of salute," as Tommy said—but the enemy was promptly silenced. Here the troops bivouacked.

On the night of the 22nd coffee was served out about twelve o'clock, and after this the whole force prepared to move.

The general orders were as follows: "At three A.M. Guards Brigade to advance from small white house near railway on Gun Kopje, supported by battery on right plus Naval Brigade; 9th Brigade on west side of Table Mountain; at same hour, bearing already taken, supported by battery on left, 9th Lancers, two squadrons, one company Mounted Infantry, marching north of Belmont Station, keeping one to two miles on left flank and advanced; Rimington's Guides, one squadron Lancers, one company Mounted Infantry from Witte Putt to east of Sugar Loaf; one company Mounted Infantry on right of Naval Brigade, protecting right; the force having got over open ground should arrive at daybreak on enemy; 9th Brigade having secured Table Mountain to swing round left and keep on high ground, and then advance east to west on A (on plan; not printed); Guards Brigade conform, being pivot; then Guards advance on east edge of Mount Blanc, guns clearing entire advance with shrapnel; cavalry to get round rear of enemy, securing horses and laager."

[Pg 87]

This carefully-arranged programme, however, was not followed in its entirety. In the grim blackness of the small hours the Grenadiers lost direction, and Lord Methuen was committed to a frontal attack. But still the attack was a brilliant success. The Boers were caught napping, for they were in the happy belief that the troops were still at Witte Putt at the very hour when they were marching steadily upon them.

The infantry tramped four miles in pitch darkness and took up their position on a long low hill facing the enemy. The Boers occupied a magnificent horseshoe-shaped position on a series of kopjes and ridges eastward of Belmont railway station. As usual, they had utilised the boulders as screens, behind which they could safely blaze away at the advancing ranks. Near daybreak—the hot summer morning dawned about four o'clock—firing began. The Guards had opened out for the attack, and the Boers, suddenly espying them from the heights, thereupon commenced to pelt and batter them. The Scots and Grenadiers nevertheless proceeded. Their position was far from comfortable, as it was necessary to cross some hundred yards of arid open veldt with no cover at all, while the enemy, ensconced behind tremendous rocks some 500 feet above their level, had nothing to do but to point their rifles and send their bullets whizzing at the advancing mass. But the Guards stoutly held their own, lying down and returning volley after volley for a full half-hour. Meanwhile the 9th Brigade advanced across the plain in extended order, and at half-past four two batteries posted near the railway commenced shelling the enemy's position.

Now the Guards began to proceed. Steadily forward they went—the thin, extended line moved as on parade, no supports being behind them.

Scarcely had they reached the base of the hill than a fierce storm of lead poured like a cascade from guns and rifles. It was useless now to attempt to return the fire—the Boers were invisible. There was no help for it; the men had only to move on and trust to their best "cold Sheffield" and their warm, gallant hearts. They fixed bayonets. Major Kinloch gave the word to his men to advance. "Now, boys, as hard as you can go!" he sang out. The other officers shouted their orders; all were dashing along like lions loosened from a cage. Cheers rent the air, bullets buzzed, cannons roared, blood streamed and spouted, plucky men and brave boys dropped dead on every side. Yet on went the infantry brigades! The first kopje was stormed! The Boers had vanished!

It was a sight to thrill the blood, to make the heart leap to the throat—so grand, so awful, so reminiscent of all the great traditions of British history. The enemy went helter-skelter to their second kopje on the right, where another force was strongly entrenched. Here they were sheltered by a number of "schantz," or trenches built of boulders and arranged in gallery form, and here our men mounted after them—Coldstreams, Grenadiers, Scots Guards, Northumberlands, Northamptons, and 2nd King's Own Yorkshires, now steadily advancing

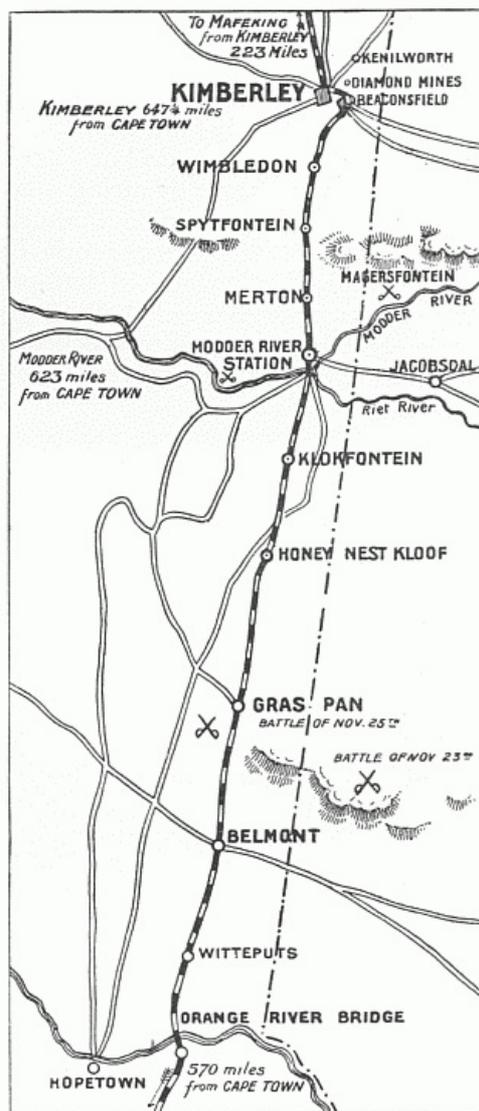

[Pg 88]

LORD METHUEN'S LINE OF ADVANCE

without excitement and with stern determination, and through a horrible cross-fire from the death-dealing rifles of the enemy.

Their advance was grand—a feat of heroism—with the Boer missiles flying about their heads and the track of blood seeming to tinge the very atmosphere with red. On and on they pushed, cheering loudly up the steep incline and over the boulders, nimble as goats, determined as giants, on and on, and, with a mighty roar, took the position. Dead men lay at their feet, but honour, with its laurel crown, wreathed their heads!

[Pg 89]

Again the Boers made a hasty, a desperate retreat; again they sought a strongly-fortified position; again, our cavalry being too far off to reach them, the infantry combat was renewed.

A hurricane of bullets poured down. Death for the third time stared and gibbered; for the third time our gallant fellows, all in mass, again advanced to the attack. The Naval Brigade brought up four guns, and Captain Prothero got his cannon in position of 1800 yards and blazed out a chorus of distraction.

The enemy fled. The rout was now complete. Away went the 9th Lancers, away went the Mounted Infantry, both pursuing the fugitives for a good five miles. Thus the battle of Belmont was won. The whole of the camp waggons, filled with boxes of clothing, hundreds of horses and bullocks, were captured, and tons of ammunition were destroyed.

But this fight, that has taken so short a time to describe, and which was over in less than four hours, was hardly won. Forms all bloodily dashed lay here and there and everywhere, and the Scots Guards, who had stormed the kopje to inspiring strains of drums and pipes, were doomed later on to hear the wail of the pibroch for many comrades mourned and buried. In all, our losses—about 200—were comparatively small considering that the engagement was a series of three battles, during which the Boers were constantly carrying off dead and wounded. Very many of our officers were wounded and three were killed. One—Lieutenant Fryer of the Grenadier Guards—was slain while gallantly leading his men and creeping along the bed of a stream in the enemy's rear. After the battle Lord Methuen made the following address to the troops: "Comrades, I congratulate you on the complete success achieved by you this morning. The ground over which we had to fight presented exceptional difficulties, and we had as an enemy a past-master in the tactics of mounted infantry. With troops such as you are, a commander can have no fear of the result. There is a sad side, and you and I are thinking as much of those who have died for the honour of their country and of those who are suffering as we are thinking of our victory."

Three instances were reported of the despicable treachery of the Boers. Lieutenant Willoughby was shot at from an ambush under cover of the white flag; a Boer holding a white flag in his left hand murdered Lieutenant Brine with his right, and Lieutenant Blundell-Hollinshead-Blundell (3rd Batt. Grenadier Guards) was shot in the merciful act of tending a wounded Boer. Lord Methuen after the fight sent a remonstrance to the Boer commander, saying, "Acting quite fairly with you, I decline to take Kimberley men who know the country, because their parole cannot be accepted. I must ask you to warn your wounded not to shoot our officers. I must warn you not to use Dum-Dum bullets, or use the flag of truce treacherously. Such action is cowardly in the extreme, and I cannot countenance it."

[Pg 90]

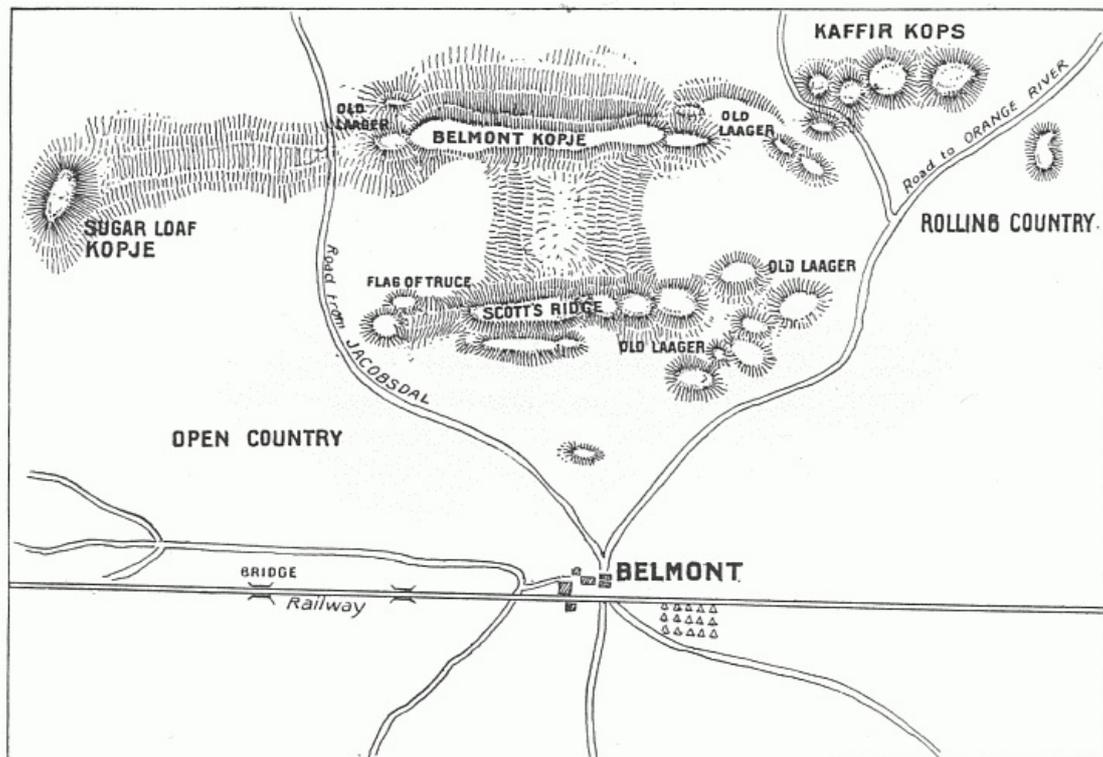

PLAN OF THE BATTLE OF BELMONT.

The Boer losses were reported as very small, but no credence can be placed on their statements, for the very good reason that it has been President Kruger's policy to conceal from outsiders, and

even from his own country, the extent of his losses. Whenever the Boer dies in battle, his body is weighted and cast into a river, or into a trench as quickly as possible. His family are left in ignorance as to his fate, and their only conclusion is to assume that he is dead. But Mr. Kruger's methods and his ruthless military oligarchy were disapproved even by his own countrymen, and more especially by his own countrywomen, who now began to mistrust the continual story of Boer victory, and asked pitifully for permission themselves to seek for fathers, sons, and brothers from whom they never heard. In some cases many of these were lying not an inch below their feet, for a British search party came upon a portion of the veldt that was literally mosaicked with dead Dutchmen whose bodies were scarcely more than peppered with earth!

Mr. Knight, the correspondent of the *Morning Post*, who was a general favourite, was wounded in a singularly treacherous manner. He was in the firing line of the Northhamptons, who were then attacking the Boers. Some of the enemy suddenly emerged from behind rocks and displayed a handkerchief attached to a rifle. On this sign Mr. Knight with two others rose, and all three were instantly shot with Dum-Dum bullets. Mr. Knight's sufferings were great, and the arm was amputated. The use of Dum-Dum bullets had been proscribed, as, after hitting the mark, they expand and cause wounds as large as a five-shilling piece. The Boers, besides using them on occasion, so manœuvred the Mauser bullets that they could act in identical fashion. Another treacherous Boer device was the wearing of the red cross upon their sleeves—an action on a par with the display of the white flag—for convenience' sake. However, it must always be remembered that the Boer armies were commandeered and cosmopolitan armies, and not disciplined troops.

[Pg 91]

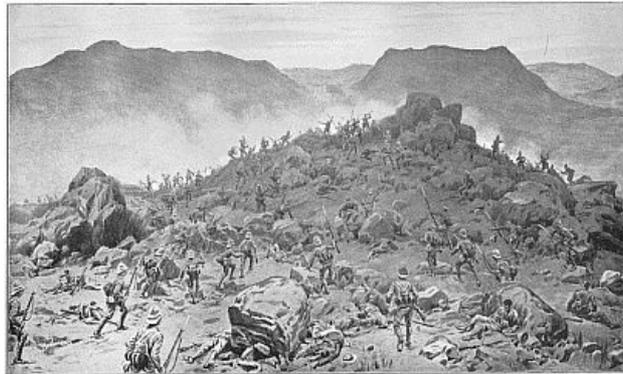

**THE BATTLE OF BELMONT, 23rd November
1899—BAYONET ATTACK BY THE SCOTS
AND GRENADIER GUARDS.**

Drawing by Frank Dodd, R.I.

During the heat of the fray Colonel Crabbe, commanding the Grenadier Guards, became detached from his regiment. He was instantly surrounded by Boers, and being wounded, might probably have been killed had not a private suddenly rushed to the rescue. The plucky fellow shot two of the enemy, silenced a third with his bayonet, and finally, amid a shower of bullets, carried off the Colonel to the shelter of an ambulance waggon. Colonel Crabbe sustained injuries to wrist and thigh, but was not dangerously wounded.

A curious experience befell the Hon. George Peel, who was trying to reach Kimberley, where his sister, the Hon. Mrs. Rochfort Maguire, was imprisoned. Roaming about after the battle of Belmont, he came by accident on a Boer camp. A Dutchman promptly emerged, and when he was preparing to meet a grim fate, deciding that all hope was lost, he found himself accosted and handed a Bible. He was in the very act of congratulating himself on his lucky escape when on the scene came two grenadiers, who seeing his battered condition and his Bible, mistook him for a Boer spy and carried him off as a prize. Fortunately he was recognised by a member of Lord Methuen's camp and liberated.

Very interesting are the following official particulars given by the General Officer Commanding the 9th Brigade to the Chief Staff Officer of the 1st Division:—

"BELMONT, Nov. 23, 1899.

'SIR,—I have the honour to submit the following report of the part taken by the brigade under my command in the action which took place to-day. The rendezvous was left at 3.7 A.M. in the following formation: Northumberland Fusiliers, in column of companies, on the left, directing, and fifty paces from them moved the Northamptonshire Regiment in similar formation, and parallel to them. In rear of both these battalions was the 2nd Battalion King's Own Yorkshire Light Infantry and two companies Munster Fusiliers." (Having described the operations which ended in the occupation of a ridge south of Table Mountain, Major-General Featherstonhaugh continues:)"This party of the enemy was finally dislodged at the point of the bayonet, and 'independent fire' poured into them at a distance of fifty yards, when a white flag was hoisted by the party. On our men ceasing fire, the white flag still being displayed, a shot was fired by this party at our men; but the actual bearer of the flag of truce, followed by some eleven or twelve unarmed Boers, surrendered themselves to Colonel Money and were made prisoners.—Signed for Major-General Featherstonhaugh,

[Pg 92]

EDWARD S. BULFIN,
Captain, Brigade Major, 9th Brigade."

The following is the list of officers killed and wounded at the battle of Belmont:—

3rd Grenadier Guards.—Lieutenant Fryer, killed; Lieutenant Blundell-Hollinshead-Blundell, dangerously wounded; Second Lieutenants Leslie and Vaughan, wounded; Lieutenants Gurdon Rebow and Russell, slightly wounded; and in addition the following officers reported as wounded: Lieutenants Lygon and Cameron, and Lieutenant-Colonel Crabbe. 1st Battalion Coldstream Guards.—Lieutenant Grant, wounded. 2nd Battalion Coldstream Guards.—Lieutenant the Hon. Claude Willoughby, slightly wounded; Second Lieutenant Burton, severely wounded. 1st Battalion Scots Guards.—Major the Hon. North Dalrymple Hamilton, severely wounded; Second Lieutenants Bulkeley and Alexander, wounded. 1st Battalion Northumberland Fusiliers.—Captain Eagar and Lieutenant Brine, killed; Major Dashwood and Lieutenant Festing, dangerously wounded; Captain Sapte and Lieutenant Fishbourne, Brigadier-General Featherstonhaugh, Captain Freeland, 2nd Northampton, Lieutenant Barton, 2nd Northampton, severely wounded.

THE BATTLE OF GRASPAN

The commandos defeated at Belmont fell back upon Graspán, the next station northwards on the way to Kimberley. There Lord Methuen decided they should not long remain. He thought, to use his own words, "that it would be best to march the division at once to Swinks Pan, which would place me on the left front of the enemy's position, and that if I worked one battery round each flank, sent my cavalry and mounted infantry well forward, the greater part of the cavalry being on the eastern side, I ought to capture the eastern force. The Naval Brigade and 9th Brigade I left for protecting the guns or assaulting a position if necessary. The Guards Brigade I left with the baggage to march to Enslin, where I had my next camp. The brigade could always give a hand if wanted. I had left 1st Battalion Scots Guards at Belmont Station, also two companies Munster Fusiliers, because there were 500 Boers and a gun, so it was said, threatening Belmont. I made this my divisional battle, marching straight from Belmont to Enslin. The armoured train with infantry was to give me a help from the line." Thus the General briefly described his programme.

[Pg 93]

On the day following the battle of Belmont, a hot, blistering day, with the sun glaring pitilessly till the heavens looked like a sheet of burnished brass, the Division, with the Yorkshire Light Infantry as advance guard, moved on towards Graspán. This place is probably called Graspán because it is the centre of a circular phalanx of huge kopjes, which, rising out of the smooth white sand, have an air of quaint picturesqueness resembling that of some ancient ruined arena. There the troops encamped. Here, in the light of the stars and rolled in their blankets, they laid them down to their hard-earned rest.

Before cock-crow, however, the men were up and doing, and as the lavender hues of dawn began to lighten the horizon, the gallant warriors were on the move. It was known that the enemy was near at hand, sneaking on the surrounding heights, therefore the last two miles were covered in fighting formation, the Naval detachment and the 5th Fusiliers being supported by the Yorkshire Light Infantry and the Northampton Regiment.

The enemy, not 400 strong as was supposed, but 2500, with six guns, one Hotchkiss, and one Maxim, was posted on a series of five kopjes over 200 feet in height, joined by neks, all of which save one were strongly occupied. In a laager in the remote distance 500 more Boers were reported to be hidden in reserve. The ground on all sides had been previously measured to find the ranges, the Boers having evidently been quite well informed regarding the British plan of action.

In advance of the troops came the armoured train, a pachydermatous monster which moved cumbrously in front of the column, and was saluted by the smoking wrath of big guns as soon as it appeared. It retired cautiously, and disgorged its gallant crew of marines to help in handling the naval guns. Lord Methuen deployed the cavalry on the flanks, while the artillery took up positions in front of the Boer trenches. Meanwhile the 9th Brigade went forward in skirmishing order. This consisted of the Northumberland Fusiliers, 2nd Battalion Northampton, half-Battalion Loyal North Lancashires, 2nd Battalion King's Own Yorkshire Light Infantry. With the 9th was the Naval Brigade, commanded by Captain Prothero. At six o'clock an active artillery duel began, the guns of the foe being splendidly posted, and their range, as before-said, carefully calculated. Their shells burst with appalling fracas over our batteries, but the brave British gunners never swerved. They gave the Boers some smart and telling replies, and presently, on withdrawing their guns to a new position, quite defeated the calculations of the enemy, whose shells now began to fall wide of the mark. The rifle-fire of the Dutchmen was not so accurate as usual, and was evidently under no control, though there were sharpshooters who crept under cover for the purpose of sniping at any prominent person who might be taken for an officer. As has been stated, there was now no outward or visible sign of rank, so for the time being the enemy's efforts were unsuccessful. They were more deadly—grievously deadly—however, when the gallant Naval Brigade, the officers of which were distinguishable by their swords, came to the foot of the hill. The fire from the kopjes was terrific, and every moment men threw up their arms and fell. They had advanced in extended order, but in converging upon the position to be taken, found themselves closed in, and in that formation attempted the ascent.

[Pg 94]

Meanwhile the rest of the infantry was moving forward in preparation for attack. The Northampton worked from the left round to the right, where they were joined by the Yorkshires and Northumberlands. All this time a scene of terrific slaughter was taking place, a tremendous and unceasing fire being poured from the Boer positions upon our steadily advancing men. But these were undefeatable, the 2nd Yorkshire Light Infantry, the Marines, and the 1st North

Lancashire acquitting themselves nobly in a most perilous situation. One after another of their numbers dropped. Stones and sand were heaped with the mutilated and fainting, and dyed with the life-blood of trusty comrades that a moment ago had been hearty and hale; but on they went, these gallant lads, while a storm of shrapnel bellowed overhead, and bullets whistled past their ears, and dust and dirt blinded their eyes. With a ringing cheer the Yorkshire men directed a fusillade towards the crest of the enemy's sangar, and then the whole mass crawled up with splendid effort, neared the summit, and prepared to charge. The Boers, however, began discreetly to remove themselves to a second position still better intrenched, from whence they could fire on the British as they gained the top. At this time the British guns were forced to be almost inactive, as the storming line was now so near the crest that the shrapnel could only be directed on the enemy by enfilading the position from the ridge of the kopje on the left, and it was during the lull that Lieutenant Taylor, Yorkshire Light Infantry, and Lieutenant Jones, of the Marines, scaled the sangar.

The next instant there was a roar and a rush, and all were leaping forward to clear the second position. This was only accomplished after some desperately hard work and a quarter of an hour's hand-to-hand fighting—an eternity it seemed to those engaged—for the kopje was stubbornly held. But even Boer pluck, of which in this case there was no lack, could not resist the impetuous advance of the British infantry, and at last, when the hill-top was one crimson crown of blood and half the gallant number were struck down, the Boers bolted one after another down the back of the hill, pursued by our artillery fire, and made for their horses. Finally, as they were retreating in hot haste across the plain, the 9th Lancers charged them, and succeeded in catching up their rear close to a kopje where they were sheltering. But here the place literally swarmed with Dutchmen, and the Lancers, whose numbers were small, and whose horses were exhausted, were forced to retire.

[Pg 95]

Still the object of the fight was magnificently accomplished. The rout of the enemy was complete. The gallant Naval Brigade, Yorkshire Light Infantry, and Loyal North Lancashires remained masters of the situation. A party of Boers who had rushed from their sheltering kopje were intercepted by the detachment of the New South Wales Lancers, who, charging, forced them back to their hiding-place.

The amazing gallantry of the Marines, who bore the brunt of the desperate fight, was the subject of general eulogy. Many of these splendid fellows had three wounds, while some had four. Sixty per cent. of the officers and sergeants were hit. Nothing could have been more heroic than the conduct of poor Huddart, who so gloriously fell in doing his duty.

Captain Le Marchant, Royal Marine Light Infantry, who was left in command of the Naval Brigade with Lord Methuen's force after the action at Graspan, reported as follows: "It is with deep regret that I have to report the death of Midshipman Huddart, who behaved magnificently, and still advanced after he had been twice wounded, until he was finally struck down mortally wounded." A brother naval officer also wrote: "At the bottom of the hill Huddart was hit in the arm, and half-way up he was shot in the leg, but still he pressed on. On reaching the top of the kopje he was shot through the stomach and fell." Captain Le Marchant, when his senior officers were killed or wounded, led the remnant of the Naval Brigade up the kopje with splendid pluck and ability.

But magnificent deeds were numerous. Lieutenant W. J. C. Jones, Royal Marine Light Infantry, though he had a bullet in his thigh, led his men up the kopje, and only after the day was won consented to have his wound dressed. Colour-Sergeant Waterhouse was also mentioned by Lord Methuen, who said in his despatch, "I beg to bring to your notice No. 1843, Colour-Sergeant Waterhouse, King's Own Yorkshire Light Infantry, who at a critical moment acted with great coolness in shooting down an enemy who had been doing great execution on our men at 1150 yards."

[Pg 96]

The General deplored the lack of a cavalry brigade and horse artillery, owing to which he was unable to reap the fruits of his hard-fought action, and all must unite to condole with this much-tried commander on the manner in which he had been handicapped from the first. Lord Methuen in his despatch drew attention to the excellent work done by the Naval Brigade near the line. He said:—

"Lieutenants Campbell and L. S. Armstrong displayed great coolness in conducting the fire of their guns. Petty Officers Ashley, *Doris*, and Fuller, *Monarch*, laid their guns with great accuracy under fire.

"I again draw attention to the exceptional organising power of Colonel Townsend. At Swinks Pan at 11.30 P.M. I was informed that, owing to all the ambulances having been used for taking the wounded to the train at Belmont, I had scarcely a field-hospital mounted officer, only three ambulances and three stretchers. I knew I had to fight next morning, so got together fifty blankets in order to carry wounded with help of rifles. I also sent to Colonel Townsend to make arrangements for wounded by 3 A.M., a messenger having to ride seven miles to him. He met me on the field with full supply of ambulances, and I never saw anything more of him or the wounded, because he had a train ready for them between Graspan and Belmont. His only complaint is that there is not much of his mules left, an observation which applies equally to men and animals."

To show how completely all the British projects were known, a curious incident of this battle may be quoted. Four men were captured by Rimington's Guides, but three of them being unarmed were released. It was subsequently discovered that these same persons had taken to the Jacobsdal commando minute details regarding the British camp, with the result that a Boer force

was detached to attack the station. The total British casualties were estimated at 197, including twenty killed and seven missing. At the close of the action, Lord Methuen complimented the members of the Naval Brigade on their splendid behaviour, and expressed regret at the losses they had sustained.

The following is the list of officers killed, wounded, and missing at the battle of Graspan or Enslin of 25th November:—

2nd Battalion Yorkshire Light Infantry.—Wounded: Captain C. A. L. Yate, Lieutenant H. C. Fernyhough, Lieutenant C. H. Ackroyd. Naval Brigade.—Killed: Commander Ethelston, *Powerful*;^[6] Major Plumbe, R.M.L.I., *Doris*; Captain Senior, R.M.A., *Monarch*; C. A. E. Huddart, Midshipman, *Doris*.

The following were severely wounded:—

Flag-Captain Prothero, *Doris*, and Lieutenant Jones, R.M.L.I., *Doris*.



[Pg 97]

PRIVATE AND CORPORAL OF THE GORDON HIGHLANDERS.

Photo by Gregory & Co., London.

Lord Methuen addressed his division in stirring words, congratulating his men on the work they had done and the hardships they had surmounted. The work, he said, was the severest accomplished by the British army for many a long day. Not a single point, he added, could they afford to give to the enemy. The Boers' tactics had been proved excellent and their courage admirable. The gallant General added that when called on to fight for his country, he preferred to fight against a foe worthy of his steel rather than against savages, whose sole recommendation was bravery. He hoped that he and his men had gained each other's confidence, and that they would all do their duty to their country as Englishmen should. Lord Methuen described as dastardly the firing by the enemy on ambulance waggons, the shooting of a British officer by a wounded Boer, and the use of Dum-Dum bullets; but he refused to believe that these acts were characteristic of the enemy; he would give them credit until he was convinced to the contrary that they wished to fight fair and square. Addressing the Scots Guards, the General said that they had acted as he expected his old battalion would.

The troops rested well on the night of the 27th, and on the following day proceeded towards Modder River, where the General was aware that the passage of the river would involve a bloody fight. By this time General Pole-Carew had taken command of the 9th Brigade, in place of General Featherstonhaugh, who was wounded.

THE BATTLE OF MODDER RIVER

This battle, to use Lord Methuen's words, was one of the hardest and most trying fights in the annals of the British army. He might also have truly said that it was one of the most gloriously-fought engagements that has been known in modern warfare. On reconnoitring the enemy's position, the Boers were found to be strongly entrenched and concealed behind a fringe of furze and foliage and in front of trees in the neighbourhood of Modder River. From native sources it was learnt that the river and the Riet River were fordable anywhere—a statement which was afterwards found to be entirely false. The enemy was discovered on the east of the village to be in

strong force and aggressive. His trenches commanded the plain for a distance of 1600 yards, and there was no means of outflanking him, as the Modder River was in flood.

The word Modder means muddy, and this term was appreciated in its full significance when our parched troops came to make acquaintance with it. But there are times and seasons when even ochreous water becomes clear as crystal to the fevered imagination, and before this day of days was over—in the sweltering, merciless sun, with the thermometer at 110 degrees in the shade—men felt as though they would stake their whole chance of existence for one half-bottle of the reviving fluid. But this is a digression. The horror of that day's thirst had barely set in at the time treated of—4 to 8 A.M. At that hour there was no suspicion that the enemy, strong in numbers, would continue to fight, and be strengthened by some 8000 more Dutchmen. He appeared to be retiring, and there were no signs that the village would be held. But at 8.10 a fierce roar of guns multifarious declared that the river was fringed by the enemy, and that he was well and skilfully concealed.

[Pg 98]

Parallel to the river on the north side the Boers had constructed, with their wonted cunning, long sandbag trenches and various complicated breastworks, which afforded them splendid cover. The line extended over some five miles, and they were discovered to be posted on both sides of the water. Where the stream of the Riet joins the Modder there is a small and picturesque island some two acres in extent. It has shelving banks all fringed with willows, and thus forms an excellent natural cover for troops. Till now this spot had been the resort of picnickers and pleasure-seekers from the Diamond City. On the north bank were farmhouses and hotels, which had been evacuated by their owners and had been taken possession of by the Boers. Here they had posted guns of every available kind, in every available spot. They had Hotchkiss guns and Maxim guns, and the deadly, much-abhorred Vickers-Maxim quick-firer, a machine which, by the way, was offered some time ago to the British Government—and refused! This objectionable weapon was christened by some "Putt-Putt," by others "Bong-Bong," and one officer styled it "the Great Mogul," because its presence was invariably greeted with profound salaams and Chinese prostrations. With these guns the enemy began to show that he meant business, as will be seen.

The division, that had been strengthened by the Argyll and Sutherland Highlanders, had moved out from Wittekopslaager about 5 A.M., breakfastless, because it was thought that on reaching the river, which was but a short march of five miles off, there would be ample time for a meal. But by seven o'clock the fighting had begun. The General had arranged with the officer commanding the Royal Artillery to prepare the infantry attack with both batteries from the right flank, and the Infantry Division being still some miles distant, he gave them two distinct points to march on, which allowed of the brigades keeping in extended order and covering a very wide front.

The Guards Brigade had orders to develop their attack first, which they did with the 1st Battalion Scots Guards on the right, with directions to swing their right well round in order to take the enemy in flank, the 2nd Battalion Coldstreams and the 3rd Battalion Grenadiers making the frontal attack, the former on the left to keep touch with the 9th Brigade; the 1st Battalion Coldstreams in reserve in the right rear. Well, before they could look about them and settle down into their positions, the whole force found itself facing the Boer commando 8000 strong, two large guns, Krupp guns, &c. The Scots Guards on the extreme right marched through the old reservoir, and directly they emerged from cover a shower of bullets greeted them. Soon after their Maxim gun was disabled by the Hotchkiss gun of the enemy, and presently their whole detachment was completely wiped out. First the sergeant in charge was killed, then an officer was wounded, then Colonel Stopford of the Coldstream Guards was hit in the neck and killed, and the horse ridden by Colonel Paget was shot in five places and dropped dead. Meanwhile the 75th Battery in return launched some magnificent shots in the direction of the Dutchmen. The third of these struck a farmhouse in which the Boers and a gun were posted, and set the whole place in a blaze. Not till the roof was burnt about their ears, however, did the Boers budge. They clung with ferocious tenacity to every position, and the fight at all times of the day was one of great stubbornness. The 1st Battalion of the Coldstream Guards had extended, and, swinging their right round, had prolonged the line of the Scots Guards to the right. Farther advance was checked by the Riet River. The troops then lay down, being fairly under cover in that position. The heat was scorching, and in the plain occupied by our troops Mauser bullets swept the field in thousands. There was absolutely no cover save the shelving bank of the river, which served no purpose directly they rose on elbow from the ground. For hours our men lay on their faces unable to show a head without inviting a shower of lead—lay on the blistering sand with the hot African sun grilling them, some of the Highlanders having their legs veritably toasted, their mouths parched and full of sand, while bullets were fluting a death-song in the air, and the thunderous detonations of the big guns seemed to be raking the very bowels of the earth. Still the Boers stuck to their posts. For hours they plied their guns without sign of exhaustion. A terrific fire was kept up on both sides for a long—a seemingly interminable—time, but without any appreciable advance in the state of affairs. It was felt that nothing could be done on the right flank till the guns had cleared the position. The 18th Battery, however, came vigorously into play, and so brilliantly acquitted itself that finally the enemy was forced to evacuate their ferociously-contested positions among the houses. But so ably had they constructed their intrenchments that from these it was impossible to dislodge them. Meanwhile the 9th Brigade had advanced the Northumberland Fusiliers along the east side of the railway line, supported by half a battalion of the Argyll and Sutherland Highlanders. The Yorkshire Light Infantry moved along the west side of the railway, supported by the remaining half battalion of the Argyll and Sutherland Highlanders. The half battalion Loyal North Lancashire prolonged the line to the left, and endeavoured to cross the river and threaten the enemy's right flank. The six companies of

[Pg 99]

[Pg 100]

Northampton's acted as a baggage-guard.

Early in the day a plucky attempt was made on the extreme right of the line to cross the Modder. Colonel Codrington and Captain Feilding of the 1st Coldstreams, with Captain Selheim of the Queensland Permanent Force with some two dozen men, forded the river. The water was almost chin deep, and while they crossed, the Hotchkiss gun directed an appalling fire on them. Though laden with all their gear and 150 rounds of ammunition, they yet succeeded in reaching the other side, where they found themselves almost swamped in mud. As they were not supported they had to retire. But this was easier said than done. On the return passage two men were almost drowned, and had it not been for the ingenious device of their comrades, who, by joining hands and slinging their putties together, managed to drag them ashore, they would certainly have perished.

Soon after this the General, who had been moving about surveying and commanding, was shot through the thigh. Then followed some confusion, as the two brigades, in the absence of orders, had to act independently of each other, and there was some fear that the 9th Brigade would fire on the 1st. Command of the field was now assumed by Major-General Sir H. E. Colville, whose headquarters were on the right close to the river. It had been Lord Methuen's idea to take the position at nightfall at the point of the bayonet, but owing to the tremendous day's work, the heat, the absence of food, and the general fatigue that all had undergone, this project was abandoned. There was another reason for the change of plan.

Just as it was beginning to grow late some of the most brilliant work of the day commenced. As the trenches were found to be utterly impregnable to rifle-fire, it was felt that only desperate measures would rout the Dutchmen from their stronghold. Colonel Barter (King's Own Yorkshire Light Infantry) and Lieutenant Thorpe, with some men of the Argyll and Sutherland and North Lancashire Regiments, started off, and, much to the surprise of the Boers, who had evidently not calculated upon such dauntless agility, got safely across the river. The wonderful way in which this feat was accomplished was described by an eye-witness, a correspondent of the *Times*.

"That it could even be attempted to cross the river sliding sideways through the rush of water over the paddles along a rickety iron bar one by one, clinging to the short supports in full view of the opposite shore, was an act of reckless heroism against which even the wary Cronje had not provided. This, however, is what was actually done, and it would be difficult to find a parallel for the stubborn pluck of the men who accompanied Colonel Barter across the 300 yards of dam and weir. One by one some 400 of them crossed. Then a detachment of the Royal Engineers, showing how well they could take their part in the forefront of the fighting line, followed them, after that some more of the Yorkshire Light Infantry. Little by little a force was collected which cleared several of the nearest houses on the right and effected an occupation of an irrigation patch from which they were never dislodged." It was quite wonderful to note the effect of the gallant British cheer which rang out from General Pole-Carew's men as they burst from the river, bayonet in hand. The Boers were startled and fled, with our men closely in pursuit. At the rousing, ringing, menacing sound, their hopes had failed—they thought that the rumour of victory was already in the air. "The thunder growl edged with melodious ire in alt," as Carlyle called it, never did better work. It demoralised and brought about the end.

[Pg 101]

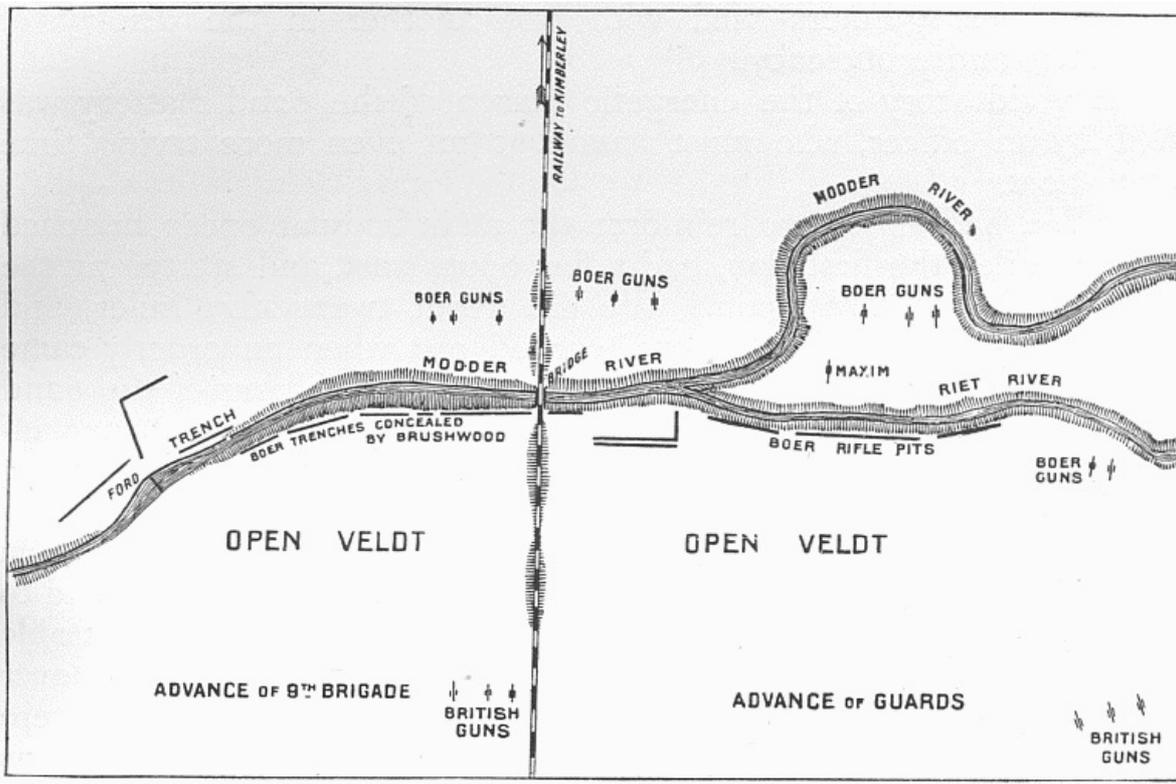

PLAN OF THE BATTLE OF MODDER RIVER

Shortly after, a battery of Royal Artillery came upon the scene, but before it had time to unlimber, more Boers took to their heels, falling over each other in their haste to be off and catch

[Pg 102]

their horses. The sound of British lungs in their rear and the sight of the guns was too much for them. Thus after twelve hours' fighting the day was practically won, for, when morning came, it was found that the enemy had entirely cleared out, and removed to fresh intrenchments half-way between the river and Spyfontein.

It was a brilliant but a hardly-earned victory. It is stated that the Naval guns fired over 500 rounds, and the 18th Battery more than 1100. The 75th fired 900 rounds, the 62nd (who came to the rescue from the Orange River late in the day), 500 rounds. The glorious gunners vied with one another in the display of gallantry and proficiency.

A vivid story of the energetic march of the 62nd Battery was told by an officer, who must have had an even more trying time than most.

"We had orders to reinforce the main body at once; marched twenty miles the first day, had a few hours' rest, and started at the first streak of dawn again. We did about twenty-five miles, and were just going to have a well-earned rest when an orderly came galloping up with the order to go at once (I am talking of the 62nd now), as the battle was going against our troops. We started off again at a trot, and kept it up for about five miles, when our horses were just done up. We had to take four out of our gun-teams, as they dropped dead of exhaustion. The sergeants hooked their own horses in, and off we went again. We lost more horses, and had to walk after we had done about eight miles. We were only able to just make the horses drag the guns into action. I shall never forget it. I was feeling very queer. I don't think any of us were afraid, but we were all of us expecting to be shot every minute, as the bullets came in showers.... We were in action in this place about two hours. Our troops were being shot down in heaps, and things were looking very black, when Lord Methuen came up to our Colonel and asked him to send his batteries up closer (we were then 1500 yards from the Boer trenches, and you must understand that a rifle carries 2500 yards). Our Colonel did. We then advanced up past our own infantry and came into action about 900 yards closer than artillery had ever taken up position before. After severe loss on our side we managed to silence the Boer guns. The order was then given to retire. We got out of range, and were on the point of congratulating ourselves on being so lucky, when up rode an orderly giving us instructions to go and relieve the Guards. Our Major advanced.... We took up our position 800 yards from the Boer trenches, and, by Jove! the Boers let us have a fearful reception. Before I got my horses out they shot one of my drivers and two horses ... and brought down my own horse. We then got my gun round on the enemy, when one of my gunners was shot through the brain and fell at my feet. Another of my gunners was shot whilst bringing up shell, and I began to feel queer.... At last we had a look in; our shells began to tell. We were firing six rounds a minute, and were at it until it was too dark to fire any more. The Boer firing had ceased, and the Guards were able to get up and retire. They blessed the artillery that day. We had to keep our position all night, with not a soul near us and nothing to eat and drink. Our orders were to open fire as soon as it was light enough, and the infantry were to take the place at the point of the bayonet.... But in the morning the Boers had fled. The field presented a terrible sight at daybreak; there were dead and dying in every direction. I couldn't describe it; it was awful. We lost heavily on our side, but the Boer losses must have been heavier. The Boers bury their dead in the trenches as soon as they drop, so that one cannot gauge their loss, but we counted hundreds."

[Pg 103]

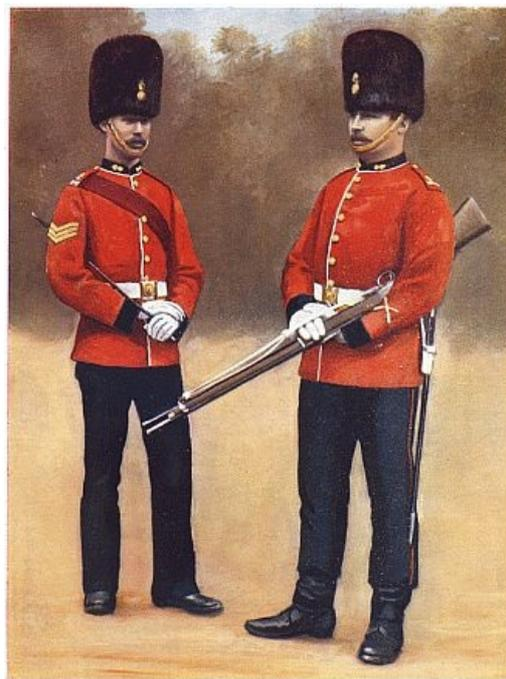

**SERGEANT AND PRIVATE OF THE
DUBLIN FUSILIERS.**

Photo by Gregory & Co., London.

It is pleasant to remember that this hurried march and its trials were fully appreciated by Lord Methuen, who reported that the 62nd Battery was of great service. It must be noted that it came

into action between three and four o'clock in the afternoon. The gunners had made a splendid forced march from Orange River in some twenty-three hours, yet there and then, with worn-out horses and jaded frames, joined in the fight.

Heroic actions were so abundant that they made quite a formidable list in the General's despatch, but they afford such inspiring reading to all who honour Great Britain's heroes, that the list is reproduced in its entirety.

"From the Lieut.-General Commanding the First Division to the Chief Staff Officer.

"MODDER RIVER, Dec. 1, 1899.

I have much pleasure in bringing to your notice the names of the following officers and rank and file who distinguished themselves during the day:—

"Major Count Gleichen, C.M.G., for the coolness shown by him throughout the engagement, especially in attending to the wounded under a heavy fire.

"Sergeant Brown and Private Martin, 3rd Battalion Grenadier Guards, who helped him, were both shot.

"Sergeant-Major Cooke, 3rd Battalion Grenadiers, displayed remarkable coolness under fire.

"Lieutenant the Hon. A. Russell showed great coolness in working the machine-gun, which he did with marked success.

"Major Granville Smith, Coldstream Guards, in volunteering to find a ford, which he did in dangerous mud and a strong river.

"Captain and Adjutant Steele, Coldstream Guards, for excellent service during the day.

[Pg 104]

"Sergeant-Major S. Wright, Coldstream Guards, showed great coolness when a change of ammunition carts was being made, and was of great value at a critical time.

"Native Driver Matthews for making the other natives stick to their carts when they would otherwise have bolted.

"Drill and Colour-Sergeant Price, Coldstream Guards, at Belmont and at Modder River rendered excellent service whilst commanding half a company.

"Drill and Colour-Sergeant Plunkett, Coldstream Guards, collected 150 men, and helped the 9th Brigade crossing the river under Captain Lord Newtown Butler.

"No. 1825, Lance-Corporal Webb, Coldstream Guards, twice asked leave to go into the open to bind up the wounds of a Grenadier; under a heavy fire he succeeded in his object.

"Captain Hervey Bathurst, Grenadier Guards, was of great value in rallying a number of Grenadiers and Coldstreams shaken by the fire.

"I again call attention to Colonel Paget's cheerfulness and intelligence under the most trying surroundings.

"He draws attention to Captain Moores, Royal Army Medical Corps, who, although wounded in the hand, said nothing, but continued his duties. Also he draws attention to the good services of the Master of Ruthven, Scots Guards. The valuable services of Captain Nugent, aide-de-camp, and Captain Ruggles-Brise are again noted.

"The names of Lieut.-Colonel Barter, King's Own Yorkshire Light Infantry, and Major the Hon. C. Lambton, Northumberland Fusiliers, are mentioned for having rendered invaluable assistance to their Brigadier. Captain Bulfin, Yorkshire Regiment, did his duty admirably.

"Lieutenant Percival, Northumberland Fusiliers, managed with great difficulty to establish himself with a small party on a point near the railway, from which, by his judgment and coolness, he was able to keep down the fire of the enemy, many of his small party being killed.

"Nos. 3499, Lance-Corporal R. Delaney, 4160, Private J. East, 4563, Private Segar, 4497, Private Snowdon, Northumberland Fusiliers, under a very heavy fire picked up and brought in a wounded man of the Argyll and Sutherland Highlanders; No. 3955, Private Smarley, Northumberland Fusiliers, No. 1 of a Maxim detachment, who showed great coolness and judgment when wounded.

"Major Lindsay, Royal Artillery, 75th Battery, ignored a painful wound, and continued in command of his battery. Lieutenant Begbie, Royal Artillery, suddenly placed in command of his battery, led it and brought it into action with great coolness.

"Captain Farrell, wounded a second time, continued to do his duty, having first placed a wounded man on one of the gun-carriages. Wounded gunners and drivers continued at their duty.

"Lieutenant Rochford Boyd, Royal Artillery, on this, as on former occasions, showed himself reliable and capable of acting without orders.

"I personally bring to notice the value of Lieut.-Colonel Rhodes's service and Major Streatfeild's service in sending forward reinforcements to Major-General Pole-Carew, for on this movement the result of the evening's success depended.

"I cannot too highly commend the conduct of the troops, ably assisted by the Naval Brigade, for on them the whole credit of our success rests."

There were some miraculous escapes, one sergeant in the Coldstream Guards having had many nasty experiences. In an account of them he said:— [Pg 105]

"During the afternoon some one seemed to have spotted me from the trenches. First a shot struck the side of my boot and struck my rifle just in front of my face, filling my eyes with dirt and splinters. I rose up a little, when another shot struck the middle finger of my left hand. I had got on my knees,

when a bullet struck me fair in the chest on the buckle of my haversack, breaking it through the centre and causing a slight puncture of the skin and bruising my chest. Have been congratulated as being the luckiest beggar in my battalion."

The terrible nature of the fighting was described by an officer in the Guards, who must have had a charmed life. He wrote:—

"We had no cover except little scrub bushes about six inches high, and the ground sloped gently down to the Boers from about 2000 yards. I don't suppose troops have ever been in a more damnable position. I sat up occasionally to see how things were going, but only for a moment, as it was always the signal for a perfect storm of bullets. My ammunition-bearer had his head blown to bits by a 1-lb. shell from a 37-millimetre Maxim, a most damnable gun. I happened to be in the line of it just before dark, and they pumped six rounds at me. The first four pitched in a line about twenty, ten, fifteen, and the fourth four yards in front of me, and threw dirt all over me, and the next two just pitched behind me. I didn't like it a bit.... It was the worst day I have ever spent in my life. Twelve hours under a constant and heavy fire of Maxims, 12-pounders, and other quick-firing guns and rifles, a hot sun, no cover, no water, and no food is more than enough for yours truly.... The guns yesterday fought magnificently, and I believe fired more rounds per gun than have ever been fired in a battle before.... We had a lovely wash this morning. I washed shirt and drawers, besides myself—I wanted it. My clothes have not been off since we left the Orange River on November 21.... Cronje and Steyn are said to have both been present at the battle."

In this battle the hardships of warfare were accumulated. Not only had the troops to display active but passive heroism. Though the longing for water exceeded the craving for food and repose, the unfortunate fellows were very near the verge of famine. Their position at times must have savoured of the tortures of Tantalus, for many of the men were groping after the enemy in a doubled-up fashion and under a shower of lead, along farms and gardens, while hens clacked, pigs grunted, goats offered milk, and potatoes and other edibles smiled a mute invitation. When the Boers were routed, however, these delicacies at last became the reward of their labours, but of the niceties of the culinary operations it is best not to speak. Our gallant Highlanders needed the services of no Vatel—an old can and a wood fire right royally served their purpose. The crossing of the river, which was so splendidly effected, particularly by the Argyll and Sutherland Highlanders, was fraught with unlooked-for dangers, as the following quotation from a letter of a private in the regiment will show. Talking of the enemy he said:—

[Pg 106]

"They held their position for five or six hours, and it was with great difficulty that we managed to shift them. Our regiment was the first to cross the river on the left flank, and my company was the first to get over. We advanced along the river and drove the Boers before us; but, unfortunately, our big guns dropped two or three shells uncomfortably close to us, entirely by mistake. When the first of these shells fell, I was only about ten yards past the spot. About twenty of our men were killed by the Boer bullets; and our regiment, I think, sustained the heaviest loss of any that took part in the fight. I felt a bit frightened when I first went into battle, but as the day advanced I got myself again. My legs are badly burned by the sun, and are very sore, but I am rapidly getting all right again. We expect to have another fight this week, and it will be even worse than the last, so one never knows the hour when he may fall."



**THE BATTLE OF MODDER RIVER, THE
ARGYLL AND SUTHERLAND
HIGHLANDERS CROSSING THE DRIFT.**

Drawing by Allan Stewart.

Indeed they did not, and it was a pathetically common experience to wish a man good luck one morning and on the next to find that his helmet and belongings were being gathered together—all that was left of him—to be sent home to his friends. For instance, there was the case of poor Colour-Sergeant Christian of the Argyll and Sutherland Highlanders, a hero who did magnificent work, but who never lived to receive the decorations he deserved. An extract from one of his last letters is full of pathetic interest:—

"We have been fairly roughing it since we came out here. I have lost everything, and have nothing but what I stand up in. I haven't had the kilt off since we landed from the boat three weeks ago, and we consider it very lucky if we can manage to get a wash once a week. Just now we are all right, as the river is close at hand. You wouldn't know the regiment now if you saw us; we are brown all over. They have taken our sporrans away and covered our kilts with khaki cloth; in fact, I believe they will be making us dye our whiskers khaki colour next. Not a man has shaved since we left Dublin, so you can imagine what we are like. I haven't said anything about the battle, as I am sure you will know more about it at home than we do here. It may seem strange, but it is true. The people at home know more

about what is going on than we do here. We have been receiving congratulatory telegrams from every one connected with the regiment, giving us great praise for our share in the battle, and really I must say the regiment did very well, considering we have so many youngsters in the ranks. The most trying part was lying down so long under fire without seeing any one to fire at. I was rather luckier, having to retire at first, and then chase some Boers out of the house with the bayonet, and then we had to ford the river and clear the north bank of the river. We were clearing them beautifully with the bayonet when a shell from our own guns burst among us. This seemed to demoralise every one, and they all commenced to retire. But, seeing this was my first fight, I couldn't see my way to retire without seeing who I was retiring from, and besides there was a lot of wounded lying about; so a major of the North Lancashire Regiment and myself succeeded in rallying ten men of different corps and held an enclosure. We were soon tackled by the Boers, but after we killed half-a-dozen of them they appeared to get tired of it and cleared off, and we managed to get all the wounded in. I believe I have got recommended for the Distinguished Conduct Medal and the Victoria Cross for my share in this, but of course it is one thing being recommended and quite another thing getting it."

[Pg 107]

Boer treachery, of which we had many examples, had hitherto been practised with monotonous regularity. They had fired on the white flag and disregarded the sacred sign of the red cross. They had shot the hand that tended them, they had used Dum-Dum and explosive bullets, but on this occasion the triumph of originality in treacherous trickery was achieved. On the principle of "all is fair in love and war," the enemy utilised their ambulance for the purpose of removing their Hotchkiss gun from the field, and that too when the precious weapon was not even invalidated!

Tales of many plucky actions which were recorded would fill a volume in itself. Private Anderson, Scots Guards, over and over again traversed the fire zone and carried off the wounded to a place of safety. Lieutenant Fox, Yorkshire Light Infantry, was seriously wounded whilst valiantly leading an assault against the enemy's strong position. When the horses approached to take the guns out of action, the Boers at once commenced to aim at them, and for the moment it seemed as though the work of removing the guns could not be persisted in. Twenty-five horses were killed, but the chargers of several officers were next utilised, and the officers themselves, some of them wounded, walked or crawled off the field in order that the valuable weapons should be borne off in safety. A driver was also heroically self-abnegating. Though shot through the lungs, he refused to leave his post, and valiantly drove his gun out of action.

The list of killed and wounded was a grievously long one:—

Killed: Staff—Lieutenant-Colonel H. P. Northcote.^[7] 2nd Coldstream Guards—Lieutenant-Colonel H. Stopford,^[8] Captain S. Earle. Wounded: Field Artillery—Major W. Lindsay, hand; Captain Farrell, foot; Lieutenant Dunlop, shoulder; Lieutenant Furse. 3rd Grenadier Guards—Major Count Gleichen, severely; Lieutenant Hon. E. Lygon, slight. 2nd Coldstream Guards—Lieutenant Viscount Acheson. Royal Army Medical Corps—Captain Gurse Moore. Killed: 2nd Yorkshire Light Infantry, Second Lieutenant L. W. Long. Wounded: Staff—Lieutenant-General Lord Methuen, slightly; bullet flesh wound in thigh. Royal Engineers—Captain N. G. Von Hugel, slightly. 3rd Grenadier Guards—Second Lieutenant A. H. Travers, slightly. 1st Scots Guards—Lieutenant H. C. Elwes, seriously; Second Lieutenant W. J. M. Hill, 1st Loyal North Lancashire—Lieutenant R. B. Flint, slightly. 2nd Yorkshire Light Infantry—Major H. Earle, Major G. F. Ottley, Lieutenant R. M. D. Fox. 1st Argyle and Sutherland Highlanders—Lieutenant H. B. F. Baker-Carr, Second Lieutenant W. G. Neilson.

[Pg 108]

AFTER THE FIGHT

All night long energetic members of the Ambulance Corps picked their way over the battlefield collecting the wounded and succouring them. Not only had our unhappy sufferers to be attended to, but many of the enemy, of whom there was an unusual number. So anxious had been the Dutchmen to clear out before our troops could reach them in the morning, that, contrary to custom, they had left wounded, doctors, and ambulance train behind them.

After the uproar of the conflict and the night of merciful repose were over, the troops were able to inspect their new quarters. The pretty little village presented a strange sight—a study in contrasts for the meditative mind. A pastoral calm reigned everywhere, though scarcely a house, farm, or hotel but could bear witness to the terrible energy of the British fire.

The scene was one of picturesque green fertility and black blistered ruin. Peacefully flowed the cool rippling river—the river in which the delighted Tommy rushed to bathe—while in its bosom lay the bodies of the slain, Boer men and Boers' horses, which had hurriedly been cast away and hidden, so that the full tale of loss might never be revealed. Serenely waved the willows and acacias on the banks and neighbouring islets, smiling with polished green leaves over the forms of the ragged, grimy, unkempt slain—the ruffraff of the Boer commandoes, who were left lying as they fell. The dark trail of blood dyed the earth round mimosa and cactus hedges, while a thousand perforations on the roofs of the corrugated iron dwellings confessed to the all too fervent kisses of British lead. Shell holes, shattered doors and broken windows, telegraph poles lying about, with their hairy whiskers twisting raggedly over the veldt, farmhouses burnt to cinders, hotels that had once been smart in their way now weevilled by shrapnel—all these things surrounded the encamped division which so brilliantly had crossed the river. And in the hearts of the conquerors there was also (in some measure) a reflection of these contrasts—there was rejoicing over animal comforts restored, the freedom to quench thirst, to remove boots, to eat and to smoke after an over-long spell of battle; yet at the same time, deep down, there lurked a numb and dumb feeling of regret for the good fellows who were going—were known to be sinking into eternity, and for those—so many of them!—who had already gone.

[Pg 109]

Very simple but very sad and impressive was the funeral of Colonel Stopford, who was shot early in the fight the day before. His grave was made in a peaceful spot beside one of the gardens of the village, and garlands gathered by his men of the 2nd Coldstream Guards were placed all over it. Major the Marquis of Winchester—so soon to join his lost comrade—acted as chief mourner. He took over the duties of Commandant of the regiment, which duties he was doomed to perform for twelve days only. But we are anticipating.

During the whole of the days following, a melancholy procession of invalids passed to the railway, and on, home for good, or to hospital, whence they hoped to return again to pay their debt to the enemy. On some death had set his mark, with others he had but shaken hands and passed on.

The river was soon found to be crowded with dead men and horses, which had been hurriedly consigned to the mercy of the waters, and arrangements had to be made for encampment farther up the stream. Quantities of Boer spies still lingered about the camp, some of them pretending to be ambulance drivers, in order to get nearer and closer inspection of British movements. Fortunately these wily folk somewhat overreached themselves, and their further activities were interrupted by arrest.

Meanwhile the sappers wrought wonderful things. They had shown the stuff they were made of by crossing over the river-dam in the teeth of the enemy. They now demonstrated their ability in their own special line. The Modder bridge was entirely wrecked, but very speedily a temporary one was constructed, and the railway, which had also suffered at the hands of the enemy, was repaired with great celerity, and brought into working order. Lieutenant Crispin of the Northumberland Fusiliers was wounded while out on patrol duty. Fortunately the injury sustained by Lord Methuen was slight, and there was every hope that he would be equal to active duty in the course of a very few days.

We must now leave this division in the enjoyment of its well-earned repose and return to Ladysmith, which was fast becoming the cage of 9000 of our gallant troops.

FOOTNOTES:

- [5] Brevet Lieutenant-Colonel Cecil Edward Keith-Falconer, born in October 1860, was gazetted to the Northumberland Fusiliers in January 1883. He was promoted Captain in 1892 and passed through the Staff College with honours. He served with the 13th Soudanese Battalion in the Dongola Expeditionary force under Lord Kitchener in 1896, and acted as Brigade-Major to Colonel H. Macdonald at the engagements of Abu Hamed, Berber, Atbara, and finally at the battle of Omdurman. In recognition of these services he was three times mentioned in despatches, promoted as Brevet-Major in March 1898, and Brevet Lieutenant-Colonel in November 1898, and received the Khedive's medal with four clasps. He acted as A.D.C. to Lord Loch when Governor and Commander-in-Chief of Victoria from 1887 to 1889, and subsequently at the Cape of Good Hope from 1889 to 1890. Colonel Keith-Falconer was the eldest son of the late Major the Hon. Charles J. Keith-Falconer, son of the seventh Earl of Kintore.
- [6] Commander Alfred Peel Ethelston, of the cruiser *Powerful*, who was among the killed at the battle of Graspan, joined the navy in 1875, and two years later became a midshipman. In 1882 he attained the rank of sub-lieutenant, was promoted to a lieutenancy in 1885, and was made commander at the beginning of 1897. As sub-lieutenant of the *Helicon* he took part in the naval and military operations in the Eastern Soudan at Suakim in 1884-85, for which he received the Egyptian medal and the Khedive's bronze star. Commander Ethelston was appointed to the *Powerful* two years ago.
- [7] Brevet Lieutenant-Colonel H. Ponting Northcote, who belonged to the Prince of Wales's Leinster Regiment, became a Lieutenant in 1877, Captain in 1886, and Major in 1894. He served in the Sherbro' Expedition in 1883 with the 2nd West India Regiment, and was mentioned in despatches, receiving a medal, and was afterwards created a C.B. In 1888 he served in the operations in Zululand as Deputy-Assistant Adjutant-General, while in 1895 he accompanied the expedition to Ashanti under Sir Francis Scott, receiving the star.
- [8] Lieutenant-Colonel Horace Robert Stopford, of the Coldstream Guards, was appointed a Lieutenant in 1874, Captain in 1885, and Major in 1893. He had not previously been on war service.

CHAPTER IV

THE INVESTMENT OF LADYSMITH

Before going farther it may be interesting to inspect a rough table showing approximately the composition and total strength of the British and Boer forces at the various points mentioned:—

BRITISH		BOER	
21st, 42nd, and 53rd Field Batteries; Battalion of Natal Artillery; two guns of the Natal Naval Reserve; Natal Mounted Volunteers; 5th Lancers; 19th Hussars; 1st Battalion Liverpool Regiment; 2nd Battalion Gordon Highlanders; 1st Battalion Devonshire Regiment; 1st Manchesters; several companies of Mounted Infantry; Medical Corps; Veterinary Corps; 23rd Company Royal Engineers; reinforcements from Maritzburg; Naval Brigade (750) <i>Following from Glencoe:—</i> 13th, 67th, and 69th Field Batteries; 18th Hussars; Natal Mounted Volunteers; 1st Battalion Leicestershire Regiment; 1st and 2nd Battalions King's Royal Rifles; 2nd Battalion Dublin Fusiliers; several companies of Mounted Infantry; Field Hospital Corps	13,550	Combined Free State and Transvaal forces	30,500

KIMBERLEY

Four companies of the Loyal North Lancashire Regiment; Battery of Royal Garrison Artillery, consisting of six 7-pounder mountain-guns; a large party of Royal Engineers; detachment of the Army Medical Corps	2500	Free Staters, and probably some Transvaal Boers, with four field-guns, 3500; on Orange River, 2000; Reinforcements from Mafeking, 1000	6500
---	------	--	------

MAFEKING

Colonel Baden-Powell, with 500 Cavalry, 200 Cape Mounted Police and B.S.A. Company's Mounted Police, 60 Volunteers, 6 machine-guns, two 7-pounders, 200 to 300 townsmen used to arms	1500	1000 Transvaal Boers under Commandant Cronje; 500 Boers at Maritzani	1500
--	------	--	------

At Tuli, or moving towards Mafeking, was Colonel Plumer's column, which consisted of about 1000 men, and was opposed by an equal force of Boers.

[Pg 111]

At Palapye there was a British force of 700, which was watched by a Burgher force of about 1000.

The Boers had also a force estimated at 3000 in laager near Komati Poort.

At Estcourt there was a considerable force under Brigadier-General Wolfe-Murray, and at Pietermaritzburg other troops.

Distributed along the northern border of Cape Colony were some 5000 Free State Boers and about 1000 or 1500 British troops and police.

The Natal Field Force was now confronted with the bulk of the Boer commandoes, whose strength was vastly superior to its own, and whose courage was generally acknowledged to be splendid. The Dutch have ever a stoical stolidity which serves them in the hour of need as does the bulldog tenacity of the Briton, and therefore "those who knew" were not without apprehension in regard to the upshot of hostilities. It was plain to all who were in any way familiar with previous history and with local conditions that the struggle was likely to be both prolonged and bloody, and they urged on the attention of those at home the need of reinforcements. Yet the soldiers, particularly those who had recently arrived, were light-hearted and confident, full of satisfaction to be let loose from their hencoops in the ships, and keen to try conclusions with the Boers. At Ladysmith the state of affairs was becoming more and more complicated, and the invasion of the Free Staters into Cape Colony was now an accomplished

fact. The enemy's tactics everywhere were acknowledged to be excellent, and where tactics failed tricks succeeded. The Boer dodges, though scarcely honourable, might be described by the Americans as "cute." For instance, an enterprising officer of the Transvaal artillery conceived the idea of utilising the flag of truce in a new and original fashion. Disguised as an ambulance driver, he arrived at Ladysmith, and improved the occasion by observing the effects of Boer artillery fire on the town.

The use of the white flag by the enemy was now beginning to be distrusted, for daily evidences of treachery were forthcoming. As one correspondent said in writing home of the subject, "Its advantages they seem to construe in too liberal a spirit, but of its obligations on the men who hoist it they do not appear to be aware." As in old times, they tried to use the white flag to assist them in going from cover to cover, or to create delay while guns were being adjusted in more convenient positions. Nor was this all. A wounded Boer accepted water with one hand from a British soldier, while he shot him with the other, and numberless accounts of dastardly deeds of a similar nature were reported and authenticated.

On November 2 the Boers began to occupy the points of vantage around Ladysmith, and telegraphic communication with the south was cut. They energetically commenced the building of emplacements for their guns of position, which were fast being forwarded from the Transvaal. Reinforcements from the Free State were also pouring in, and a Boer commando was creeping towards Colenso. In spite of threatened serious inconveniences, hopes were high and spirits cheery, especially among the newspaper correspondents, who, regardless of danger, drove four-in-hand round the camp and fortifications, and helped to maintain a devil-may-care attitude that was certainly reassuring. Ammunition was plentiful, but water—Klip water—was somewhat inclined to cause colic, and, in consequence, to be generally suspected. It was no uncommon sight to see at the Royal Hotel ladies heating their kettles prior to drinking their doubtful contents. Flies were so numerous as to make another persistent inconvenience. They destroyed such repose as the inhabitants might otherwise have enjoyed. Added to these petty discomforts were night-alarms of various kinds, and curious and disconcerting discoveries. For example, one young man—an immaculate young man—well turned out and apparently plentifully endowed with ready money, was discovered to be a Boer spy, and was promptly arrested. An account of the last days of a British sojourner in Ladysmith serves to give an example of the trials and anxieties through which hundreds had to pass:—

[Pg 112]

"Since my last note to you we have had some lively times of it at Ladysmith. I always had a liking to see a real battle, but never thought that it would be my luck. However, I have now seen four battles, and I think that I am satisfied. I can assure you that it is anything but pleasant to go on the field after battle. The sights of the wounded and dead are horrible, and yet the soldiers are always laughing and joking when they are going out to fight, and the poor fellows are getting very little rest. They never have a chance to get their boots off. They have to be always ready to move at a moment's notice, and they do it with light heart. Your heart would have ached to see the lot that came down to Ladysmith from Dundee. They were not strong enough for the Boers, so they made a forced march of it, and they had terribly bad weather. It was raining all the time, and when they came into Ladysmith they were mud all over and in rags. Some of them were carrying their boots in their hands and could hardly crawl. Mrs. V. and myself made some buckets of coffee and let them have a pull at it; and were not they thankful for it? A word about how we are going on here. I don't know whether you are getting any news at home about the war, but we can't get to know anything here, as the whole country is under martial law, and they won't let the papers publish any news concerning the war.... Now the Boers are all round Ladysmith, and our troops can only defend the town. I don't think for a moment that the Boers will take Ladysmith unless they get strongly reinforced, and I don't think that will happen. However, the sooner that troops arrive for the relief of the garrisons that are here and hemmed in by the Boers the better it will be for Britain. There is no doubt about it that the Boers have got our troops in a tight corner, and Britain is a bit slow, not having her troops here before now. I hear that troops are likely to land next week, and I hope that it is true. I had to leave Ladysmith on November 2; the military authorities would not grant me a permit to stay, so they gave me my free pass to Durban, where I intend to stop until the trouble is over. You would have laughed to see some of the men running out into the street with no clothes on when the Boers sent their first shell into Ladysmith. It came into the town at 5.15 A.M. I was up and partly dressed, as I had heard the firing, and was going to have a look at the battle, when in came the shell right over the house I was staying in and dropped on the road. I was sure that it was going to hit the house. The shell makes a terrific whistling as it travels through the air.... The Bluejackets did some very good work. They arrived by train about eleven o'clock, and by twelve o'clock they had off-loaded their guns and got them into action, and their third shot silenced the Boers' 40-pounder."

[Pg 113]

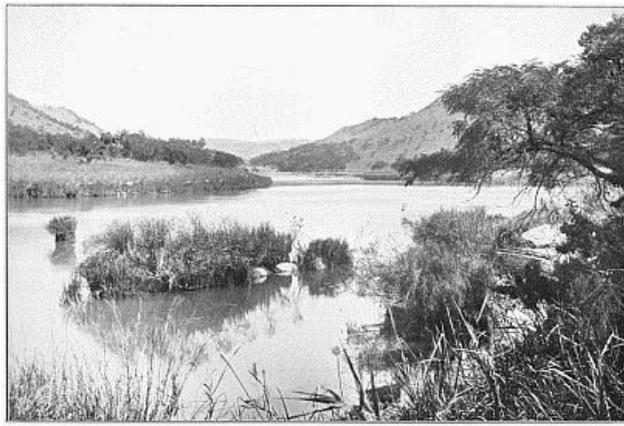

SCENE ON THE TUGELA.

Our cavalry while reconnoitring discovered a large force of the Boers which was manœuvring to the south of the town. The troopers charged, and succeeded in cutting their way through the enemy. Meanwhile at Grobler's Kloof the Volunteer Light Infantry, a corps that had been doing splendid work throughout, met the enemy, and a sharp encounter was maintained, but they were outnumbered by their assailants. An armoured train brought troops to their assistance, and these enabled them to return safely to headquarters. The naval gunners were active, and scored as usual, for they finally succeeded in putting the big gun on Hepworth Hill out of action. "Long Tom," an objectionable weapon and a great favourite with the enemy, was now posted on Mount Umbulwana, whence at intervals it spat viciously upon the town, but without causing serious damage. The enemy, as we know, made a move towards Colenso, and the officer commanding at that place decided to fall back with men and horses on Estcourt. The move over some twenty miles of hilly country was admirably executed, and all stores, huts, kit, &c., were preserved.

Meanwhile Sir George White sent out a strong force under the command of Colonel Brocklehurst, reinforced by the 5th Dragoon Guards, Royston's Horse, and two batteries, for the purpose of making a flank attack on the Boer commando that was advancing on Colenso. Splendid work was done, the Boers being routed from all their positions and three guns silenced. The Imperial Light Horse pressed too far into a gully, and for a time their position was critical, but they were extricated by the 5th Dragoon Guards. The Boers took up a strong position on the hills, and were shelled with terrific effect by the British artillery. Finally they retreated, and were cut to pieces by the cavalry. Quantities of prisoners were made, and over a thousand burghers were said to be slain—in fact, the veldt was a complete parquet of dead Dutchmen. Lieutenant the Hon. R. Pomeroy, 5th Dragoon Guards, greatly distinguished himself by pluckily riding to the rescue of a dismounted trooper and carrying him out of the fire zone. Captain Knapp and Lieutenant Brabant were killed.

[Pg 114]

At Ladysmith there was temporary peace after the enemy's fire had succeeded in hitting the hospital and a hotel. Fortunately no one was injured. All were mourning the loss of Major Taunton, Captain Knapp, and Lieutenant Brabant, who fell in the engagement on the previous day. General French, by what is termed "a close shave," succeeded in getting out of Ladysmith, and went down to Cape Town to take over the command of the Cavalry Brigade, and General Wolfe-Murray at Estcourt, with a mounted battery, reconnoitred in the direction of Colenso. Efforts were made to restore communication with Ladysmith, but in vain; yet the troops within kept up a cheerful attitude, and a continuous artillery duel was carried on between besiegers and besieged.

The art of dodging shells had by this time begun to be studied by the least nervous, for no place was safe from these screeching messengers of death. Hard roadways were rent in twain and deep gulfs dug in their midst. Gardens, from being trim and neat, became a scene of upheaval and dilapidation; the open veldt was strewn with dust and debris, and rocks were shot from their positions and sent hurtling here and there to assist in the work of wreckage. It was curious to notice upon different temperaments the effect of the shells' arrival. Some persons might be seen holding their hands to their heads as though to protect them from damage; others shrank under the nearest available cover or screwed themselves up as though endeavouring to make smaller parcels of themselves, or hoping to lessen their own obstructiveness to the passage of the devilish invader; some would flatten their backs against a wall—make pancakes of themselves—while others would fall prone to earth, and there grovel till the moment of peril was past. Many would rush helter-skelter towards the river-caves, vast places of refuge that had been dug into the deep-shelving clay and sandbanks of the Klip, and there, in their rocky hiding-places, breathe freely and await the inevitable fracas that told them, temporarily, that the coast was clear. These caves and their powers of accommodation began to be deeply interesting to the community, and daily the soldiers were set to work constructing new ones for the safety of the apprehensive. The places varied in size and quality according to the demands of their tenants. Some would accommodate a dozen people standing upright in them, and even admitted of furniture of a rough kind—bedding, seats, eatables, and cooking-pots—just enough to enable nervous folks to go "out of town" for a day or two during a period of bombardment. Others were mere fox-holes, as it were, alcoves scooped out of the bank to serve as a screen for the more hardy souls who were content to breathe the air of the river-brink, and only popped their heads under cover in ostrich fashion when danger threatened. The banks thus became honeycombed, and it was not unusual

[Pg 115]

to find a whole family perched all day long with their backs against the protecting wall and their eyes fixed meditatively on the purling stream, awaiting with resignation the whims of "Long Tom."

In the early days of the siege a great deal of scooping and excavating went on, and you might see on one side some gallant tiller of the soil providing cover for a lady, while another rigged up sheltered garden-seats for children. An amusing picture was beheld of three massive Gordons in their kilts plying pick and shovel for a small couple in distress, a natty little woman in a state of panic which agreed badly with her smart ribbons, and her small lord who shared her anxiety for a place of safety. The Scotsmen delved and scooped and built the temporary shelter, indulging in the gayest jokes, and laughing and talking the while delicious "Aberdeen awa," till the hearers became so absorbed and interested that they almost forgot the fact that such a thing as a "Long Tom" existed. The daily operations were also of a highly-spirited character, for the British forces not only defended themselves with the greatest animation against artillery somewhat superior to their own, but at times took the offensive and harassed the enemy considerably. On three different occasions they made attacks on the Boer batteries on Umbulwana Hill, and though the British losses were somewhat heavy, those of the Boers were still greater. A message was sent by Sir George White to General Joubert requesting him to allow women, children, and non-combatants to leave the town in order to escape the effects of the bombardment, and the Boer General invited those who wished to go, to do so under protection of the Umbulwana guns, but intimated that all who had borne arms would be treated as prisoners of war. Finally, however, after a meeting had been held and the matter discussed threadbare, it was decided that the citizens of Ladysmith could accept no terms from the enemy, and the meeting dispersed to the tune of "God save the Queen," in which all fervently joined in chorus. The only means of communication with the outer world was now by pigeon-post, and there was therefore much excitement when Lieutenant Hooper (5th Lancers) arrived on the scene. Guided by a Natal policeman, he had managed to sneak unnoticed through the Boer lines and to reach the British camp in safety. [Pg 116]

All sorts of efforts were made to save Ladysmith from her doom, and an armoured train was sent from Estcourt for the purpose of reestablishing communication with the town, but the train had to return without accomplishing its mission. In spite of this, the proprietor of a hotel in Ladysmith very cleverly managed to travel from the beleaguered town to Estcourt without being captured by the Boers. He made a detour along Kaffir paths in order to elude the Boer outposts, riding all night and arriving at his destination unharmed. At that time, as may be imagined, the investment of Ladysmith was almost complete. The enemy's big guns dominated the town east, north, and west, "Long Tom" pursuing its annoying and disquieting vocation with intermittent vigour. Most of the people had now quitted their homes and were taking refuge in the caves before described, while the shops, in default of customers, were closed. The convent, which was occupied by nuns together with the wounded, was struck by a shell, but happily without injury to its inmates. The neutrals betook themselves to a camp under Mount Umbulwana, which some inventive person appropriately christened "Funkumdorf," but there some plucky women and children refused to go, preferring to cast in their lot with the valiant defenders of the little town. At this time people and horses were still in good condition and spirits; the military inhabitants amused themselves with polo and cricket, as though there was no chance of being bowled out by "Long Tom," while the ladies gave little concerts for the amusement of the select circle. So great was the pluck of this little community, that they even edited a paper called the *Ladysmith Lyre*, a species of Transvaal edition of *Truth*, which, if not *vero*, was certainly *ben trovato*.

A new instance of the Boers' treachery soon took place. They sent in under a flag of truce a number of refugees from the Transvaal. They were met outside the pickets by a flag of truce from Ladysmith, but no sooner had the parties separated, and before the British could reach the pickets, than the Boers fired upon them. These continued breaches of the laws of civilised warfare continued to exasperate the troops, who, whenever they got a chance, naturally tried to wipe off old scores.

On the 9th November, the King's Royal Rifles and the Rifle Brigade in the north, and the Manchester Regiment in the south, succeeded in repelling two simultaneous attacks, inflicting on the Boers a loss roughly estimated at about 700 to 1000. A deep trench which had been made by the enemy on their temporary retirement, to bring forward horses, was promptly captured by the Rifle Brigade. From thence, when the Boers returned, they were briskly fired on, with the result that they retreated in hot haste across open ground. Taking advantage of this opportunity, the artillery commenced an effective fire, inflicting on the Dutch considerable loss. The Manchester Regiment, which occupied a position at Cæsar's Camp, for the purpose of protecting the south-western side of the town, caught several hundred Boers hiding from shells in a ditch. They poured on them several volleys, and the enemy suffered severely. Unfortunately, Lieutenant Lethbridge (Rifle Brigade) was mortally wounded, and Lieutenant Fisher, of the Manchesters, received a slight wound in the shoulder. About noon, after seven hours' continuous fighting, the combined attack upon the town failed and the Boers retired. Then, in honour of the Prince of Wales's birthday, the big guns in the Naval redoubts commenced a salute of twenty-one guns, each shot in stately procession following the other and bursting over the Boer positions. Outside the battery, on King Kop, stood Sir George White surrounded by his Staff. The General led the way by raising three cheers for the Prince, and then Captain Lambton and the gunners on the top of the breastwork took up the roar and passed it on to the Rifle Brigade, lying in their sangars along the top of the ridge, till the whole atmosphere was vibrant with loud and prolonged cheering. In the evening the troops drank to the health of his Royal Highness, and succeeded in [Pg 117]

sending home telegraphic congratulations. On that day the townspeople, for greater safety, went into laager on the racecourse, and the military lines were removed some three miles out, so as to avoid the persistent shelling of the enemy. Major Gale, R.E., was wounded while sending a message.

Efforts were made to establish heliographic communication between Estcourt and Ladysmith, but the atmospheric conditions were entirely against the success of the operation. Bombardment continued, and life was pursued to the continuous thunder of the Naval guns firing lyddite and the "Long Toms" of the Boers, now within a three-mile range, replying with persistent and deadly reverberation. But the community in Ladysmith were not so depressed by their incarceration as to lose the spirit of fun altogether. In default of other entertainment, they beguiled the time by indulging in various practical jokes at the expense of the Boers. The greatest achievement was the preparation of a smart dummy, on which the irate Dutchmen wasted a considerable amount of ammunition. The effigy was manufactured of straw and attired in the uniform of the Lancers, by whom it was modelled. Its imposing form, placed near the Boer position, had an air of lifelike reality, and naturally the enemy jumped at a chance of riddling so venturesome a foe. Away whistled Mauser bullets round the head of the supposed courageous Lancer, who budged never a bit. Shot failing—the big gun was turned on. Bang, bang! Boom, boom! Still was the warrior unperturbed. After considerable expenditure of both shot and shell, the truth, much to the disgust of the assailants, dawned upon them!

[Pg 118]



COMPLETE MACHINE GUN DETACHMENT OF MOUNTED INFANTRY.

PHOTO BY ELDRIDGE, COLCHESTER

So pleasing was the success of this manœuvre, that the Liverpools, for further recreation, got up a miniature Tussaud's. They arrayed a row of martial effigies, and waited with the glee of school-boys while the artillery from the neighbouring hills pounded away at what they imagined to be some dauntless Britons who dared to defy them.

Efforts to signal to Ladysmith by heliograph still continued to fail, at least to reach those for whom the display was intended, though the Boer heliograph graciously acknowledged the communication. It answered jocosely, "Will be with you to-morrow." The British reply was monosyllabic! The pigeon-post medium was resorted to, and by this means those outsiders struggling for its relief were informed that with Ladysmith all was well.

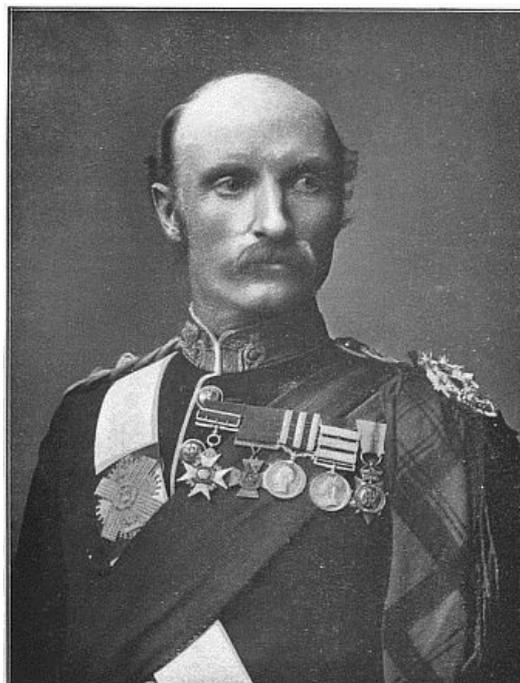

GENERAL SIR GEORGE STEWART

WHITE, V.C., G.C.B., THE DEFENDER OF LADYSMITH.

Photo by Window & Grove, London.

The process of pigeon postal communication was exceedingly interesting. Mr. Arthur Hirst, who at the onset of the war had started a loft of the best Yorkshire racing pigeons at Durban, settled himself at the Intelligence Department Headquarters, Ladysmith, and from thence sent out his intelligent birds. Of these he had some 200, all of which were trained by himself and his assistants. His early experiments were most successful. He despatched thirteen pigeons to Durban, a distance of 200 miles, yet they arrived safely with messages within five hours. The birds were returned from thence for more work. After that time Mr. Hirst continued training a hundred young birds to travel from the seat of war to Ladysmith, and great interest was taken by all who began to understand that news of the outer world would shortly be very limited indeed.

[Pg 119]

On the 14th the Free State troops took up a position on a small kopje whence a British battery strove to rout them. There was some smart cannonading, till the British were forced to fall back on the town. Their day assault over, the Boers tried a new experiment, that of a midnight attack. All the Afrikaner cannon simultaneously opened fire on the town, turning the sleeping scene into a lurid inferno. Several buildings caught fire, and the whistling and shrieking shells at intervals made terrifying music in the weird silence of the night.

ESTCOURT

Opinions regarding Estcourt differ. Some consider it a picturesque and verdant little village, placed in the bosom of the hills and very similar to a Sussex hamlet on the Downs. Others have described it as well deserving the name of being the hottest and most unpleasant region in the high veldt of Natal. It is in the thorn country, and is surrounded with rough irregular kopjes. The railway bridge over the Bushman's River is an imposing structure, and the line leads from Durban to Maritzburg, Colenso, and Ladysmith, and thence to the Orange Free State and the Transvaal. A little lower down the river is a substantial bridge that runs across from Estcourt to Fort Napier, a quaint-looking structure, neither ornamental nor useful, for hills behind and round it command the situation. Thus commanded, it is utterly indefensible, and would need an army corps to hold it. The garrison, under Brigadier-General Wolfe-Murray, at this time consisted of the Royal Dublin Fusiliers, the Border Regiment, one squadron of Imperial Light Horse, Natal Field Artillery, and some scouts. This small force would have been absolutely inadequate to the defence of the place had it been seriously attacked. The Boers in hordes were supported at Colenso by heavy guns, while the British troops that had to evacuate that village had but one obsolete nine-pounder manned by volunteers. The absence of good guns was everywhere deplored. At Ladysmith the position was merely saved by the hasty arrival at the very last moment of the Naval Brigade with their formidable weapons, and at Colenso the regrettable evacuation was obligatory solely on account of the lack of guns. The depressing effect of retreat on the unhappy colonists who had their homes in the neighbourhood may be imagined.

[Pg 120]

From Estcourt on a clear day, with a northerly wind blowing, the exciting sound of hostilities in the neighbourhood of Ladysmith was distinctly to be heard, the deep bass of "Long Tom" booming upon the air, while the heavy baritone of the 4.7 Naval guns kept up the diabolical duet. Intense curiosity as to the doings of the besieged prevailed, but it was impossible to do more than mount up some of the highest hills and look down into the cup of shadow where Ladysmith was known to be. In that direction the hollow presented the air of an active volcano, volumes of smoke floating upwards, and spreading their message of bombardment and resistance far and wide. But nothing active could be done. The tiny garrison, it was true, was receiving reinforcements, but these came in by dribbles. General Wolfe-Murray engaged himself in planning defences which should at all events make Estcourt into a hard nut to crack, and caused redoubts and intrenchments to be constructed so that the place might be safe against such attack as the Boers would make. The troops were kept in excellent training, to ensure their fitness to take the field at a moment's notice.

On the 9th of November there was general satisfaction owing to the safe arrival, under a flag of truce, of ninety-eight wounded from Dundee. The officers among them were Colonel Beckett of the Natal Field Force, Major Hammersley, Lancashire Fusiliers; Captain Adam, A.D.C.; Captain M'Lachlan, Major Boulton, King's Royal Rifles; Lieutenant C. N. Perreau, Captain Dibly, Dublin Fusiliers; and Lieutenant B. de W. Weldon of the Leicesters. There was also some grim rejoicing in hearing reports that were brought in that the Boers in their attack on Ladysmith had suffered severely, and that Bester's Farm, to meet the strain, had been turned by them into a hospital. The first detachment of the long-looked-for division was now expected, and every one in camp began already to think the siege of Ladysmith might be considered a thing of the past.

Nothing warlike took place for some days. On the 14th, however, at noon, the sound of three guns gave evidence that parties of the enemy had somewhere made their appearance. The garrison—now counting the West Yorks—numbering some 3000 men, stood to arms. Colonel Martyn, in command of the mounted troops, at once started off in the direction whence a crackling of musketry proceeded. The Boers, in some force, were located on the summit of a hill firing at our scouts, who quickly retired. Two guns of the Natal Field Artillery were at once sent for, but their arrival was a signal for the enemy to beat a hasty retreat. Their retirement was merely momentary, however, for they went along a chain of hills, and appeared again on another

[Pg 121]

eminence in full force. A squadron of the Natal Carabineers attempted to turn their flank for the purpose of ascertaining their strength, and in so doing estimated their numbers at about 500; any effort to dislodge so large a party would therefore have been useless, and Colonel Martyn with his small force was just about to retire to the hills above Estcourt, when the Boers were observed to be on the move. They were evidently preparing to clear off, which they rapidly did, particularly when assisted by a volley from the Natal Carabineers, whose nimble horses clambered up to the crest with marvellous celerity. After this, in default of sufficient cavalry, there was no choice but to retire. Men and horses were absolutely "dead beat." The expedition, with the mounting of the almost impregnable hill, had occupied six hours. This, however, was only an example of the many, almost daily, encounters that were necessary to arrest the enemy in his advance to the south.

ARMoured TRAIN DISASTER AT CHIEVELEY

So little is known by civilians of the nature and appearance of armoured trains, which played so prominent a part in the war, that a rough sketch of the "altogether" of one of these ungainly and diabolical machines may here be given. Armoured trains are hastily-constructed affairs, consisting of a locomotive and a few waggons, the engine generally being located about the middle of the train. The waggons and locomotive are covered by boiler-plating three-quarters of an inch thick, as firmly riveted as time will allow. One of these trains was constructed at Mafeking, where there are several railway shops, the town being on the new main line from the Cape to Buluwayo. The locomotive is the only part of the train that does not carry guns, the steel casing being solely to protect the mechanism of the engine from the shot of the enemy. The remainder of the armour is thickly perforated with portholes, through which guns of varying calibre peep, the Maxim, Nordenfeldt, and Gatling being the most serviceable weapons for this kind of work. The smaller holes are for the rifles of the marksmen, and usually the deadliest shots in a regiment are, when possible, selected for the position. It takes an expert marksman to shoot with satisfactory results from a quickly-moving train. Usually an armoured train is also supplied with a powerful searchlight, in view of a possible night attack. Of course, the boiler tubing can offer no resistance to artillery. In fact, rifle shots fired at short range will sometimes penetrate the plates, and to meet such a possibility sand-bags are often provided, as was the case in the Egyptian campaign, when the Sirdar found the armoured train of great service. The man in command of an armoured train thinks first, when an emergency arises, of his engine. So long as that remains in workable condition the odds are on his side; but once the vital parts of the locomotive are damaged, the outlook becomes serious, for an armoured train can only carry a small body of men, who would be quickly surrounded by the enemy, who might number hundreds or thousands. The chances are that an armoured train could not be damaged to such an extent unless artillery, dynamite, or some equally destructive force were used.

[Pg 122]

A machine of this kind, but of third-rate pretensions, was now continually used by the troops at Frere for the purpose of discovering the whereabouts of the enemy, and on the 15th of November an exciting and disastrous voyage was made in the "death-trap," as it was called. The troops had orders to proceed from Estcourt to Frere, and beyond if possible, to ascertain how far the line was practicable for the passage of an army.

The crew of this train consisted of Captain Haldane (Gordon Highlanders), in command of some seventy non-commissioned officers and men of the Dublin Fusiliers, Lieutenant Frankland, Captain Wylie, and Lieutenant Alexander, with forty-five non-commissioned officers and men of the Durham Light Infantry, and five Bluejackets under a petty officer. Mr. Winston Spencer Churchill, who was acting as war correspondent to the *Morning Post*, also accompanied the party, and in addition to him were certain railway employees to repair damages. No sooner had the train got to Frere and telegraphed "all well" than trouble began. It started to go still farther forward, in spite of the fact that natives were seen gesticulating warnings. On reaching Chieveley Station, it was found that there were Boers, who had hitherto been lying in ambush, eagerly looking out for them. These were posted in large numbers on either side of the line. Of course, the train began at once to steam back, but even as it did so a volley was poured on it from the enemy. With hideous clatter the bullets thudded on the iron, and several cannon began at once to play on the unlucky machine. Then, to add to its misfortunes, without pause or warning of any kind, the trucks suddenly, with a jerk and a crash, leapt into the air. They, at least, appeared to do so, overturning in the act, and shooting their contents helter-skelter, "like potatoes out of a sack." The words are quoted from the description of a sufferer who himself experienced the unpleasant sensation. Several of the men were mortally injured. A platelayer was killed on the spot. The cause of the disaster was simple and easily to be explained. The Boers had laid a trap for the train, and placed an impediment on the rails behind it, so that on its retreating journey it should become a complete wreck, and thus place the troops entirely at their mercy. And their ingenious machinations succeeded.

[Pg 123]

The enemy, triumphant, then opened fire with a Maxim and two 9-pounders from a kopje covered with brushwood, while Boer sharpshooters hidden in dongas and behind boulders also assisted. The Dublins and Volunteers fought gallantly; thrice they drove the enemy back, but the brave fellows, already suffering from the shock of having been shot with great force on the line, were from the first at a disadvantage, and unable at once to gather themselves together to meet the instantaneous fire of the Dutchmen. All they could do was to scramble to their feet—some were too securely jammed under the trucks to be freed—take up a position as firm as barked knees and bruised spines would allow, and defend themselves against the sudden attack. Mr. Churchill and

Lieutenant Frankland immediately called for volunteers to help in clearing the line. Many hearty voices responded. Wildly they worked amid a hailstorm of bullets to free the engine and remove the wreckage, Mr. Churchill, between the screams of the injured and the rattling of the rifles, rallying the men and helping them, though every moment volley after volley picked off some of their numbers and sensibly thinned them. Some of these men were not only men but marvels; they worked with the zeal of giants and the pluck of heroes. Vigorously the Dublins and Durhams continued to fire at the unseen enemy, while the rest of the party by sheer main force got the engine into working order, smashing everything in its way, and packing it, as tenderly as possible, with the helpless creatures whose groans and cries were in themselves enough to make the blood of the stoutest hearts run cold. Every man seemed bent on eclipsing the courage of his comrade and following the example set by the gallant war correspondent. Sergeant Bassett of the Dublins roared his orders with firm and steady voice, giving his men the range with an air of cool unconcern that was truly reassuring, while Wright of the Durham Light Infantry was also conspicuous. During the turmoil he fired from the knee in the regular position, and was as calm and collected as if he had been at a rifle-range. With each shot he cracked a joke and kept his comrades from getting excited. All this time the poor fellow was wounded, half his right ear having been shot away. Private Kavanagh, the wag of the Dublins, chaffed his comrades, telling them the Boer shells were harmless, they could hit nothing "at all, at all!" and Corporal Dickie, though wounded and lying on his back, continued to bellow to his mates, "Give 'em beans, boys! give 'em beans!" And meanwhile Mr. Churchill, though rained on with lead and almost stunned by the noise, was coolly giving directions for the lifting of the wounded and for the moving of the engine. Finally, he had the satisfaction of getting the engine and tender safely charged with their mutilated human freight and started on the melancholy return journey. Swiftly the train steamed off, protected by the fire of Dublins and Durhams, and as it did so, Mr. Churchill, who went with it a little way, but who had stoutly refused all requests to continue farther, returned to the help of such of the wounded as had been left behind. His noble self-sacrifice, however, was of no avail. Directly afterwards he was set on by the enemy and made a prisoner, in company with two brave officers, Captain Haldane and Lieutenant Frankland, and fifty-eight of the wounded. The unfortunate party was then marched in the pouring rain to Colenso. On the following morning they were taken to the Boer camp before Ladysmith, and thence *via* Modder Spruit to Pretoria. In the course of the journey a great concourse of persons crowded to see the captured, and in justice to the Boers it must be said that there was only one exception to prove the rule that courtesy on all sides was observed.

[Pg 124]

An officer writing of the armoured train affair at Chieveley so well described the glorious deeds that were performed that his version was quoted even by war correspondents. It is therefore reproduced here.

"The train," he writes, "had gone on past Frere towards Chieveley, when a party of about 200 Boers were seen evidently watering their horses. After watching them for some time the train reversed, and went back at a fair speed. On rounding a curve, a truck containing men of the Durham Light Infantry toppled over, almost burying the inmates. Fortunately the men had room to scramble out, although three or four had almost to be dug out before they got free. In the meantime the Boers were pouring a rifle-fire into the train, and were working their big guns and Maxim as fast as it was possible for them to load and fire. The Dubs (Dublin Fusiliers) in the truck in what was now the rear of the train were firing as hard as they could, and the Naval men on an open waggon at the rear opened fire with their 7-pounder, but after about three shots it was put out of action. Gradually all the men got out of the overturned truck, and, seeking cover behind waggons, returned the Boer fire, but the enemy was so well protected that hardly a man could be seen. It soon became apparent that the foe being in overwhelming force and provided with heavy artillery, the best thing was to endeavour to get the road clear.

"Twenty volunteers were called for, and it was at this point that Lieutenant Winston Churchill so distinguished himself. With the greatest coolness he superintended the operation of getting the trucks free of the line. He encouraged the men at work by walking about in the open with bullets flying round him, and telling the working party not to mind the Boer fire, as the aim was bad.

[Pg 125]

"The engine was backed and then pushed against the trucks on the line, and it was when this operation was going on that another truck, behind which the men were firing to cover the working party, fell over and injured one or two D.L.I. seriously. They had been ordered to stand back while the engine butted against the derailed trucks, but they evidently did not hear the order.

"After nearly an hour's hard work and harder fighting, the line was clear enough for the engine to go forward, but the waggons behind had to be uncoupled and left. The Dubs who were in them and the Naval men, however, had got out, and had gone away in extended order, and the engine had moved on just when the line was clear.

"Captain Wyllie was shot in the thigh and dropped. Sergeant Tod, who had also been injured in the hand, went to the Captain's assistance and built up a cover of stones as a protection against rifle-fire. Just as he was lying down a shell burst right in front, scattering the stones in all directions, and some of the pieces struck Tod in the hip, inflicting an ugly but not a serious wound.

"The engine in the meantime had gone forward, and was brought by Lieutenant Churchill to pick up as many wounded as could be found. Captain Wyllie and Tod were taken up on the tender, and the engine went on some distance farther, when Captain Haldane of the Gordons and Lieutenant

Churchill jumped off and joined the men fighting their way back; but the Boers were now closing all round, and the engine barely got through."

The *Echo*, in a leading article, spoke warmly of Mr. Churchill's exploit. It said: "In this affair Mr. Churchill, though a non-combatant, displayed the courage of his stock, and cheered the men in the work of rescuing the wounded and the bodies of the dead, crying, 'Come on, men!' with all the courage that his father showed in political warfare or his great ancestor on the fields of Blenheim or Malplaquet. When the engine steamed off, Mr. Churchill remained behind to help. Every one will hope that he is not killed."

It is somewhat interesting here to note Mr. Churchill's soliloquy on his journey in an armoured train, published in the *Morning Post* at the very time the noble fellow was suffering for his bravery on an identical trip. "This armoured train," he said, "is a very puny specimen, having neither gun nor Maxims, with no roof to its trucks and no shutters to its loopholes, and being in every way inferior to the powerful machines I saw working along the southern frontier. Nevertheless it is a useful means of reconnaissance, nor is a journey in it devoid of interest. An armoured train! The very name sounds strange; a locomotive disguised as a knight-errant—the agent of civilisation in the habiliments of chivalry. Mr. Morley attired as Sir Lancelot would seem scarcely more incongruous. The possibilities of attack added to the keenness of the experience. We started at one o'clock. A company of the Dublin Fusiliers formed the garrison. Half were in the car in front of the engine, half in that behind. Three empty trucks, with a plate-laying gang and spare rails to mend the line, followed. The country between Estcourt and Colenso is open, undulating, and grassy. The stations, which occur every four or five miles, are hamlets consisting of half-a-dozen corrugated iron houses, and perhaps a score of blue gum trees. These little specks of habitation are almost the only marked feature of the landscape, which on all sides spreads in pleasant but monotonous slopes of green. The train maintained a good speed; and, though it stopped repeatedly to question Kaffirs or country folk, and to communicate with the cyclists and other patrols who were scouring the country on the flanks, reached Chieveley, five miles from Colenso, by about three o'clock; and from here the Ladysmith balloon, a brown speck floating above and beyond the distant hills, was plainly visible.

[Pg 126]

"Beyond Chieveley it was necessary to observe more caution. The speed was reduced—the engine walked warily. The railway officials scanned the track, and often before a culvert or bridge was traversed we disembarked and examined it from the ground. At other times long halts were made while the officers swept the horizon and the distant hills with field-glasses and telescopes. But the country was clear and the line undamaged, and we continued our slow advance."

Little did he know when these thoughts passed through his busy brain that in a few days he would find himself in the State School of Pretoria, a prisoner, far from kith and kin, and uncertain whether or not he, like others, might be tried by Judge Gregorowski, who would take a grim pleasure, as he did in the case of the Uitlanders, in sentencing him to death. On this score great anxiety was felt, and it is no exaggeration to say that his countrymen, whether friends or strangers, were all equally regretful at his loss, and deeply anxious as to the fate that might befall so gallant a descendant of a great line.

ESTCOURT

Things were now going from bad to worse. The Ermelo commando, some 2000 strong, with six 7-pounders and two French guns, took up a threatening position near Ennersdale, with a view to attacking Estcourt at an early date, and there was every chance that the place would be surrounded.

Meanwhile the inhabitants of Ladysmith reported themselves in good health, some of them having taken refuge during the daytime in the caves by the river-bank, returning to their homes only to sleep. The war-balloon continued to attract a great deal of the enemy's attention, and they expended a vast quantity of ammunition in taking pot-shots at its tranquil form as it floated on the skyline of the hill behind the hollow from which it was sent up. Lieut.-Colonel Sir Henry Rawlinson, of the headquarters staff, while aloft making a reconnaissance had a narrow escape. A shrapnel shell pierced the balloon, came out on the other side, and burst some distance beyond. Had it exploded while traversing the gas-bag, the balloon and its occupant would have been done for; as it was, the balloon made a gentle and dignified descent, and the sole casualty reported was "one balloon wounded."

[Pg 127]

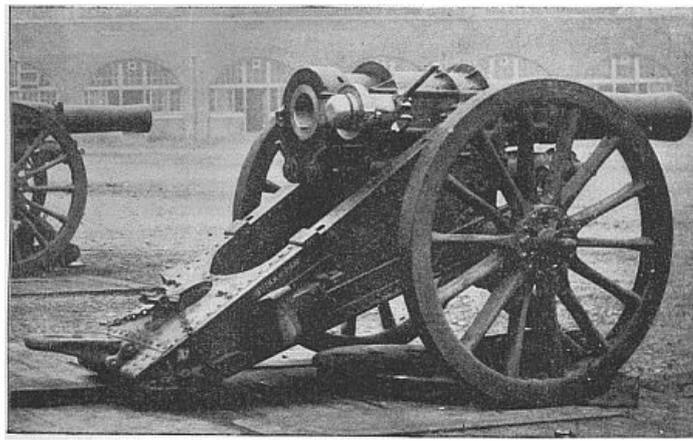

TYPES OF ARMS—THE 5-INCH HOWITZER OR SIEGE GUN.

PHOTO BY CRIBB, SOUTHSEA

Various commandoes were now seen advancing towards the railway bridge, which is half a mile north-west of Estcourt, and also from a northerly direction. Upon this General Hildyard's force stood to arms. The outpost fired on the enemy, and one shell at 8000 yards' range was launched from the Naval guns. The effect was good, for the enemy with all celerity retired. At the same time around Ladysmith the Boers were continuing their bombardment from four strong positions: the first at Wonona, the second on Intintanyone Hill, the third on Umbulwana Hill, and the fourth at Grobler's Kloof. Sorties from time to time took place, thus frustrating the intention of the enemy to make the investment closer. Sir George White's lyddite shells were discovered to be more effective than those of the Boers, many of which were charged with sand, and jocosely said to be "made in Germany." As a matter of fact, the shells were charged with cordite which had probably grown stale and ineffective from over-keeping. It may be remembered that they were stored for use against the British after the Jameson Raid.

[Pg 128]

On the 19th November General Hildyard found that it was necessary either to reinforce the mounted troops that were posted at Willow Grange, thus dividing the forces at his disposal, or to evacuate the place. He decided on the latter alternative, and thereupon the Boers, with delighted expedition, commenced to make preparation for a triumphant progress to Maritzburg.

The weather now grew intensely hot, and at night the fall in the thermometer became almost dangerously pronounced. In fact, the troops had all the discomforts of India without the conveniences commonly at hand in that country for the amelioration of its conditions. The railway between Maritzburg and Estcourt was cut, and further aggressive action seemed to be brewing. All news from Ladysmith came out either by pigeon-post or by Kaffir runners, who, in a manner peculiar to themselves, managed to get through the enemy's lines. Food in the beleaguered town was still moderate in price, meat being tenpence a pound and bread threepence. A good deal of concern prevailed because the country between Ladysmith and the south was fast being taken possession of by the enemy, and the peaceful farmers and loyalists in the vicinity were shaking in their shoes, spending days and nights in an agony of suspense as to their future and the safety of their belongings.

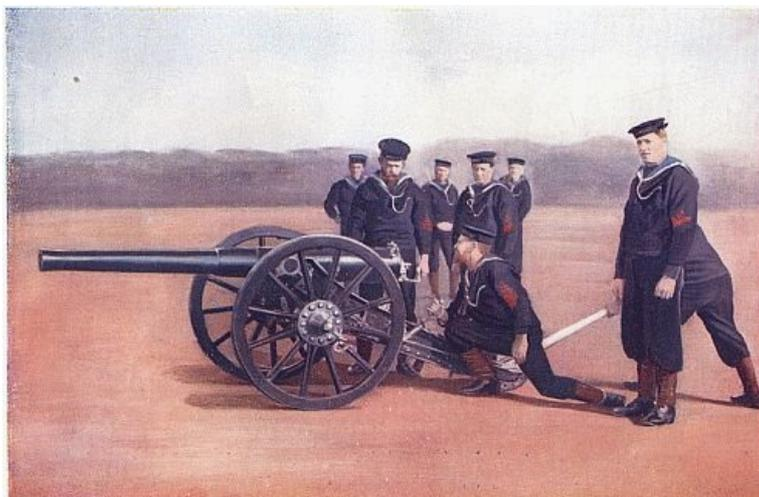

SIGHTING A NAVAL FIELD GUN.

Photo by Gregory & Co., London.

The people in the neighbourhood of Willow Grange at this time had some exciting and alarming experiences. The Boers bound for Maritzburg, of course, made their way into such farms as suited them. They had encamped themselves on the surrounding kopjes, and these soon became living hives, moving hills, of horses, cattle, and human beings, dotted with some fourteen or fifteen ambulances carrying red-cross flags. They endeavoured to make themselves agreeable to such of the inhabitants as remained, assuring them that they did not intend to hurt those who sat

quietly on their farms, though they meant to loot and raid everything from deserted homesteads. Here is a description given at the time by an owner of a farm who entertained Field-Cornet Joubert to breakfast—a plucky lady who determined to show that the Boers had no terrors for her.

"We hurried breakfast, and had hardly finished when the yard was full of men, galloping all through the trees. I went out, and was fiercely greeted with, 'Where are the other two men? We have taken three prisoners (Thorneycroft's scouts) out of five, and two are here.'

[Pg 129]

"They rode into the stable, looked through my outside bedroom door, dairy, and every conceivable place. Luckily, the men got clear.

"Shortly afterwards the Boers began to pass, cutting fences and riding in all directions, anywhere through the homestead; no discipline whatever, just like a pack of hounds when the fox is lost. They lined our kopjes overlooking Willow Grange, Weston, and Estcourt. They could hear the cannon at Ladysmith, and were not more than a mile from the house. But as scouts our boys are not in it. No stranger would have believed that stony hills were full of men and horses. I don't think that there were more than 400 or 500, evidently the advance-guard. We were kept lively the whole time, as almost every man and horse came into the yard for water, which is in a spring fifty yards from the front door, and had to be got out in buckets. They asked for anything and everything except meat. We gave as long as we could, thinking discretion the better part of valour. They invariably offered to pay, but our answer was, 'We are under martial law.'

"On Monday three men came to commandeer our carriage horses, one riding-horse, and my youngest boy's pony. We argued; but no! They must take them, as they were big and fat. My husband had almost given it up, being tired out. When they entered the stable, I stood by my favourite and slated them. The men were not Boers, but some of the scum who have joined.

"One, as ugly as sin, replied, 'Well, we will allow the lady to keep her trap-horses, but we will take the two riding-horses. We want this flat-backed, nice-looking pony for a stout man.'

"Then followed a scene. My son, aged eleven, rushed and threw his arms round his pony's neck, sobbing, and shouting out, 'I'll shoot the first Dutchman that touches him' (the boy is a cadet).

"'What a — of a row, mates; let's clear.'

"It was too much even for that scoundrel.

"Within an hour they brought down the troop branded N.G., put them in the kraal, caught unbroken mares with foals—anything the wretches could lay hands on.

"I stood by, and said, 'Are you Boers (farmers) like ourselves or vagabonds? I'll put a fire in the grass for you.'

"A genuine Boer remonstrated with them, but it was of no use; so, for a loaf of bread, he agreed to take a note to Commandant-General David Joubert.

"I wrote explaining matters, and received a courteous reply, saying they had no authority from him. He called later on, and told us to resist them; that if he required anything he would write, and send one of his own officers; and Mr. Kirby must go into the camp and pick out all the horses—an honour he declined, saying we were under martial law, and he wished to have nothing to do with them.

[Pg 130]

"On my going out to meet General Joubert, he sat on his horse, pipe in mouth, slouch hat well pulled over his ears.

"His aide-de-camp said, 'Our Commandant-General.'

"I shook hands, and said, 'Commandant who?'

"He replied, 'David Joubert;' he's only a second-cousin of the other.

"Later on we had a visit from Commandant Trichardt. He also expressed regret, saying he had men of all nations, and could not keep order.

"But it's funny to watch them. They never salute an officer or stand at attention; they talk and crack jokes round them, and when ready, say, 'Let's be going.' This, mind, to men in command.

"They shot our sheep.

"I sent my youngest son into camp. The Boers asked after several people, whom the child did not know. They crowded round him a dozen deep. The young native with him began to cry, but the boy enjoyed it. He picked out a number of horses, which they eventually caught again and cleared with. He spotted the ugly fellow who wanted to steal his pony, and called out, 'You wanted to take my horse, and to-day you've got Scrick, the fright.'

"The others laughed and jeered the fellow.

"They told us some funny tales. One was that the balloons are the English people's gods, but Slim Piet sent £5 worth of shot at one and brought it down, as he wanted to see it.

"Another was, 'We don't mind Rhodes, but show us old Franchise; that's the man we want.'

"Some say they are tired of this life, as they have it 'bitter sware,' but will fight for their country for five years, as they believe this is the war the Bible speaks of. After this we shall have a thousand years' peace.

"On Sunday a skirmish took place. David Joubert's son was wounded. They fired on to the Hoek farmhouse.

"On Wednesday heavy firing was heard in the direction of Willow Grange, and on Friday every man was on the alert. We, knowing nothing of the outside world, expected a night attack, and put food and wraps ready for the night, as we were afraid of the British shells coming on to the house.

"They advised us to hoist the white flag, but we steadily refused, nor will we carry a flag of truce, as they advised, if we left the house for a hundred yards....

[Pg 131]

"One man came for dry firewood, and tried to be agreeable; gave a very vivid description of our balloons, and finished off by saying, 'You would have laughed last night (Friday night). The Dutch and Fusiliers got mixed up. When they found it out, one ran one way and one the other. The Fusiliers shot one of our scouts only; but they are good fellows, these Fusiliers; they are nearly as tough as we are.'

"One had a big lump out of his leg, his hand blown off, and a hole in his cheek. He stood up and said, 'Well, I've had enough.' He further said, 'The Fusiliers can fight; we fought them seven and a half hours before we took 1200 prisoners. They fought hard, and would not give in.' He evidently admired them.

"The Dutch troopers carry all they have with them on horseback (no transport); they have one blanket, one mackintosh, and live principally on meat (grilled); each cooks for himself. They sleep out in the open veldt—no tents, except for their heads; and one Boer said he had never had his clothes off for a month. They water their horses, and then swill their faces in the dregs.

"Our neighbour had deserted his home. They turned his house into a hospital, hoisted the red-cross flag on his chimney, and have broken and destroyed everything about his place, killed off his sheep, &c., eaten bottles of fruit, and broken the bottles.

"The description they themselves gave of wrecked homes was heart-rending. Some of them sported all sorts of loot, and were dressed in clothes that were never bought by them.

"I offered (through a trooper) to exchange Field-Cornet Joubert hats. I would give him a new grey felt helmet for the one he wore—a battered, brown, hard felt hat, bound with Transvaal colours, two bullet-holes right through the crown, just above the band. No doubt he had placed it on a stone as a target. I was told he had been in hospital with a wound in his leg, got at the same time his hat was hit, but he was so strong and tough he soon came out again. I don't know if he would have exchanged, as I only made the offer the morning they retreated. I thought of sending it to our museum."

On the 20th of November some 700 Boers from Weenen took up a strong position at Highlands, which is situated some thirteen miles from Estcourt. They occupied two farms north-east of the Mooi River. On the following day communication with Estcourt was interrupted and the telegraph wires south of the place were cut, and later on the lines were torn up. That done, the Boers began to shell the Mooi River village. They were posted in two strong positions, but their fire, though accurate, did little damage. Cattle-looting was briskly continued, the enemy varying the monotony by firing at intervals. In this district alone the direct loss to the loyal colonists amounted to over £25,000. From the north a hot artillery fire was poured into the Mooi River camp, while from the west further Free State commandoes were marching in. Great caution was observed in the camp, as it was known that the enemy had entirely captured the railway line, and there was no knowing what their next tactics, or rather dodges, might chance to be.

[Pg 132]

THE FIGHT ON BEACON HILL

Some definite action was now bound to be attempted, for after the evacuation of Willow Grange the investment of Estcourt was practically complete. The enemy, some 7000, with eight big guns and led by the Commandant-General, had taken up a strong position about six miles south of Willow Grange. There was nothing now between him and Maritzburg but the force at Mooi River, and, in fact, there was no knowing how soon he might overrun the whole colony of Natal.

The curious entanglement of military operations at this time formed a puzzle that, had the British not been too gravely interested, would have afforded them entertainment. The rules of no known military war game could be applied to the situation, and its uniqueness was a matter as incomprehensible to the tactician as to the ignoramus. For instance, from Maritzburg to Ladysmith one side alternated with the other at intervals along the line. There were British troops at Maritzburg, Boers at Balgowan; British at Mooi River, Boers at Willow Grange; British at Estcourt, Boers at Ennersdale; British within Ladysmith, and Boers without. To the Commander this complicated sandwich of friend and foe must have been most confounding, and the upshot of the war, even by experts, could no longer be hopefully foretold.

Sir George White was surrounded at Ladysmith, General Hildyard at Estcourt, and General Barton at Mooi River, and the Boers seemed able, after detaching troops sufficient to form three

forces, consisting in all of about 17,000 men, still to be going onward with 7000 odd towards the sea.

During the afternoon of the 22nd of November a column moved out of camp in the direction of Beacon Hill to check the Boer advance. No sooner had they started than a tremendous downpour of rain accompanied by heavy thunder began to transform the whole earth into one huge morass. Naturally the already heavy task of marching was made doubly severe; but the splendid "Tommys" nevertheless plodded steadily over five miles of undulating ground, always steep in parts, and now terribly slippery from slush. Torrents continued to fall, accompanied by large hailstones, but still the troops moved on, arriving eventually at the foot of Beacon Hill where the Boer camp was situated, and beginning with steady and dogged steps to climb. Rivulets swollen by rain were successfully crossed, swamps negotiated, and massive boulders stumbled over. The force, which consisted of the 2nd Battalion West Yorkshire Regiment, half 2nd Battalion of Queen's, seven companies 2nd Battalion East Surrey Regiment, and the Durham Light Infantry, on reaching its destination, bivouacked for the night. A Naval 12-pounder gun was placed on the summit of the hill, and the 7th Battery Royal Field Artillery was also in position. These forces were under the command of Colonel Kitchener, who was directed to make a midnight attack and seize the enemy's guns and laager. The Border Regiment from Estcourt was to arrive in the morning and assist in the operations.

[Pg 133]

Unfortunately the troops, while taking up their position at the base of Beacon Hill, were discovered by the enemy, who at once blazed out with their artillery. Thereupon the Naval gun from its post on the hill snorted defiance, and from this time the Boers remained on the alert. Nevertheless in the grey gloom of the early dawn the ascent was begun, the West Yorks, supported by the Queens and East Surreys, struggling to the summit over steep and rocky ground. From the base of the hill on the left flank of the enemy's position a wall led straight to the crown, and this wall and the absence of beaten tracks helped to make the already hard task additionally arduous. However, by patience and perseverance the crest of the hill was at last gained, and the troops, with a lusty cheer, cleared out some 150 Boers at the point of the bayonet. These with remarkable agility fled to a second position, on which the bulk of their force was situated. So precipitate was the flight that thirty horses were left behind and captured, together with saddlery and camp equipment. The West Yorks then took up a position on the hill behind a barricade of stones.

Meanwhile hard work during the afternoon and night of the 22nd and 23rd had been taking place in other directions. The Naval gun, supported by the Durham Light Infantry, with the greatest difficulty had been transported over the veldt, and lugged by sheer force of muscle up the almost inaccessible mountain. The route of the strugglers lay either across sponge or rock, and the choice was not exhilarating. The 7th Battery of Field Artillery also toiled manfully in bringing guns up the steep incline.

When the day broke, the enemy opened fire from the surrounding kopjes, and the Yorks finding the Boers had to an inch the range of their position, were then forced to retire. A heavy Boer gun had been posted on a hill to west of Willow Grange Station, and this murderous weapon blazed away at the infantry with unabated zeal, though our guns warmly returned the fire. The Boer shells did practically no damage, while our shots from the Naval gun failed to reach the hostile quarters, its range being shorter than that of the Boer weapons. However, the object of the reconnaissance was attained, namely, to prevent the enemy from taking up certain positions overlooking Estcourt and from spreading farther to the south. The mounted troops, under Lieut.-Colonel Martyr, were directed to co-operate at daylight by a movement towards Willow Grange Station, and subsequently to patrol towards Highlands. Bethune's Mounted Infantry Regiment was directed to operate on Colonel Kitchener's right flank. The troops under Lieut.-Colonel Martyr, after holding a party of some 300 Boers south of Willow Grange, moved to the support of Colonel Kitchener's left flank, where they did valuable service in helping him back and assisting to get the wounded of the 2nd Battalion West Yorkshire Regiment down the hill. The troops, after being under arms from 2 P.M. on Wednesday 22nd to 5.30 P.M. of Thursday 23rd of November, gradually returned into camp. The 2nd Battalion West Yorkshire Regiment was the last to retire. During the movement the Border Regiment, Durham Light Infantry, and Natal Royal Rifles held Beacon Hill, supported by the 7th Battery of Artillery. The Imperial Light Horse, Carabineers, Natal Police, and King's Mounted Infantry took conspicuous parts in the engagement. The Volunteers, by their well-directed volleys, compelled the enemy to remain at a respectful distance. General Hildyard commanded, and Colonel Kitchener, Lieut.-Colonel Martyr, and Major Mackenzie of the Carabineers did yeoman service. A curious feature of the fight was the fact that Boer women must have been engaged on the hill, as some of their side-saddles were captured among the guns, ammunition, blankets, &c., seized by the West Yorks when the Boers were routed from the hill-top.

[Pg 134]

Many acts of gallantry and devotion were performed, especially by Lieutenant Nicholson, Corporal Wylde, and Private Montgomery. Private Montgomery, though shot through the thigh, went on firing, and when shot through the other thigh, refused to be taken to the rear for fear of exposing the stretcher-bearers. Major Hobbs was made prisoner while attending to a wounded man. General Hildyard especially commented on the valorous behaviour of Lieutenant Davies, Mounted Infantry Company, King's Royal Rifles. This young officer, under a heavy fire, dismounted, disentangled the reins of a horse he was driving in front of him, and assisted one of his men, who had lost his horse, to mount and escape. Lieutenant James, Royal Navy, who commanded the Naval gun, greatly distinguished himself in his efforts to reach the enemy's

[Pg 135]

position, in spite of the persistent attentions of a Creusot gun which had the range of him. Captain Bottomley, Imperial Light Horse, rescued several of the wounded under a heavy fire, and Lieutenant Palmer, R.A.M.C., while attending the sufferers, was taken prisoner. He was subsequently released. An amusing story was told of a trooper who was found to have shot a very smart Boer, dressed in the regulation coat and polished leather boots. "He was," explained Tommy, "such a swell of a toff, that one couldn't help potting him." One of the West Yorks also viewed life with much pluck and some jocosity. Though hopelessly shot through the neck, with the bullet emerging in his left eye, he still demanded tobacco, saying, "Ah wor varry near killed befoor wi' fallin' off a house, but ah'm noan dead yet, and ah'm noan bown to dee." Let us hope the plucky fellow lived to give his doctors the lie. The glorious behaviour of all men of the West Yorks was especially eulogised. They conducted themselves heroically; and those of the 2nd Battalion East Surrey behaved with great gallantry under most trying circumstances.

During the fight Lieutenant Bridge, R.A., attached to the Imperial Light Horse, under a heavy fire of both shot and shell rushed to a wounded man of the West Yorks, picked him up, slung him over his shoulder, and brought him to a place of safety. Trooper Fitzpatrick, I.L.H., brother of the author of "The Transvaal from Within," and a prominent member of the Reform movement—specially referred to in General Hildyard's despatch—was killed while gallantly helping to save a wounded man. The West Yorks' ambulance had just been reached when the poor fellow was caught by a bullet in the back of the neck. He was buried in the afternoon with military honours, his body being carried to the grave by his comrades. Our loss was estimated at eleven killed and sixty wounded.

This highly successful night attack was, strategically speaking, of prodigious value. The hostile hordes that were advancing to the south with the intention of overrunning the Colony of Natal were summarily disposed of, their treatment at the hands of Colonel Kitchener and his small force being such that they preferred not to try conclusions with him again for some time to come. They at once took themselves off to Colenso, and in a very short space of time the telegraph lines and rails between Weston, Estcourt, and Frere were restored. The arrival of the first trains in camp was greeted with uproarious cheers.

LADYSMITH

The inhabitants of Ladysmith had almost begun to accustom themselves to the promiscuous arrival of shells at odd hours throughout the day, when General Joubert hit on the happy idea of varying the monotony of the daily routine by making the night into a "lurid inferno"—the term is borrowed from the Boers. Now no sooner were the besieged wrapped in slumber than boom! bang! a shower of 94-pound shells was launched into their midst. In an instant all was confusion. Strange forms, some weird, some grotesque, all terrified, fled from their beds and hung hovering in gardens and verandahs, uncertain whether to believe their eyes and ears. The nights were mostly dark, and from the black ridges occupied by the enemy came with a swish and a roar red tongues of flame and the spitting, splitting fury of bursting steel, which produced in the mind of those who had recently been folded in the arms of Morpheus a sensation as of fevered nightmare or threatened madness. But the sturdy soon attuned themselves to the terrific reality, though for some days, while the midnight cannonading continued, many of the more nervous were well-nigh distraught. The bombardment was accounted for in different ways. Some said it was to celebrate a victory over the advance-guard of Hildyard's brigade, others declared that the firing had been attracted by some companies of the Liverpool Regiment who had gone to cut firewood, and were visible in the gleams of the moonlight. This midnight uproar continued for several days with more or less vigour, and then it languished, possibly from economy, possibly because the Boers themselves desired to sleep. On the 18th Dr. Stark, a naturalist who had come to Natal to study birds, was killed as he was standing near the door of the Royal Hotel, a shell having descended through the roof and come out by the door.

[Pg 136]

It grew ever more and more difficult to communicate with the relieving forces, as the Kaffir runners stood in fear of their lives, many having been killed during their hazardous journeys. Shells from "Long Tom" and the new gun on Bulwana continued to cause horror in the daytime and to pursue uninterruptedly their mission of mutilation. The porch of the English Church was destroyed, several rooms of houses wrecked, and splinters and flying fragments of brick and rock kept all who moved abroad in a state of suspense and mental anxiety. No! not *all*. There was one imperturbable Scot who occupied a house between the Naval guns and the Boer position, who watched the havoc played by the shells in his house or garden, and occasionally applauded with the remark, "Aye, aye! Lord, man, that wuz a hummin'-bird damned weel hatched!"



**FACSIMILE OF PAGE OF
NEWSPAPER PUBLISHED IN
LADYSMITH DURING THE
SIEGE.**

On the 21st an inhuman action defaced the ordinary programme of warfare. As before said, the Town Hall had been turned into a hospital for sick, and this, by reason of its conspicuous clock-tower with the red flag flying above it, made a convenient mark for the shots of the enemy. In spite of all remonstrances, the Boer commandant proceeded to batter the place with shell after shell, with the result that on one occasion the wing of the hall was destroyed, fortunately without loss of life, and on another, a shell breaking through the roof, some nine poor patients were wounded and one killed. The General had chosen this way of expressing his annoyance that his proposed arrangements were not complied with. He had insisted that the wounded should be taken to the neutral camp at Intombi, where they would have been virtually prisoners. This could not be allowed, and therefore he was evidently determined, out of spite, to make the life of the unhappy sick in the hospital a long-drawn agony. They were helpless, stricken in body and nerve, and the perpetual crashing of bursting steel, the rending of buildings in their vicinity, was almost worse than the pang of actual death. Still, in spite of everything, the garrison bore up wonderfully and tried to put a good face on matters. A message sent out on the 25th of November, even showed signs of spurious jocosity. The writer said, "Shells and flies very numerous, but the latter more annoying." There was a pathetic ring in the little pleasantry. In reality, valiant Ladysmith was beginning to droop with the suspense of hope deferred that maketh the heart sick. The heat was getting terrific, and cases of fever were beginning to appear. The Boer firing was becoming more accurate, and their commandoes seemed to remain at their full strength, some 10,000. The besieged lost about seventy head of cattle—a terrible mishap at this crisis—and these could not, unfortunately, be recovered. A party went in pursuit of the valuables, but had to return worsted! The total casualties up to this date were eight killed and twenty-three wounded. Searchlight for night-signalling began to be in continual use, and Sir George White, being fully acquainted with the plan of campaign, was preparing himself to co-operate whenever the great hour and moment should arrive. The third big cannon, which had been christened "Franchise," now began to open fire on the tunnels in which the British were said to be concealed, and assisted actively in the already murderous chorus. On the 29th, much to the joy of the community, a message from the Prince of Wales was received, thanking officers and men for the birthday congratulations they had succeeded in forwarding to him. Hopes of speedy relief revived. It was known that General Clery had by this time some 23,000 men (including Natal Volunteers) coming to the rescue, and these, together with Sir George White's 9500 in Ladysmith, would, when the time for junction should arrive, make a not insignificant total with which to meet the Boers. But the troops were beginning to grow somewhat restless and impatient for the hour when they should be let loose to settle their little account with those outside. At this juncture Commandant Schalk-Burger grew "slimmer" than ever. In order still further to cramp Sir George White, the Dutch general sent to him a crowd of some 400 coolies, on the score that they were British subjects whom he could not feed. As it was impossible to receive any addition to the numerous mouths already inside the place, Sir George suggested their being sent on to Estcourt; so the little ruse was defeated.

[Pg 138]

[Pg 139]



**FIX BAYONETS! REPELLING AN ATTACK
FROM THE TRENCHES AROUND
LADYSMITH.**

Drawing by R. Caton Woodville.

ESTCOURT AND FRERE

Tugela Drift was next attacked by the enemy. Some 300 Boers advancing from Helpmakaar were met by Umvoti Mounted Rifles under Major Leuchars and some Natal Police under Sub-Inspector Maxwell. Two good hours of fighting ensued, after which the Boers turned tail and made off. Here we must note that every one spoke highly of the Natal Mounted Police. The members of the force, mostly gentlemen, were fine horsemen and crack shots. Being Colonial bred, they were conversant with every inch of the country, having done splendid service in Zululand, Pondoland, and the outlying districts. Their experience was, therefore, invaluable.

At this time two important events took place, the Tugela River rose, and became impassable save for boats and punts, and the long-looked-for arrival of Sir Redvers Buller at Maritzburg was the signal for general rejoicing. He now began the direction of operations.

So many are the minor yet exciting incidents of war, that it is impossible to recount them; yet in these minor incidents many glorious lives have been heroically hazarded, and indeed sacrificed, with scarce any recognition from the country in whose service the daring deeds were done. Some idea of the adventures of scouting parties may be obtained from an account given by the correspondent of the *Natal Times* on the 25th of November.

"A patrol party of sixty members of the Rifle Association went out to-day under Captains Gough and D. E. Simmons to locate the enemy on the Berg side of the railway.

"They found the enemy encamped on Simmon's farm, and commissariat waggons on Blaker's farm, about twenty-two miles from here, and seven and a half west of Mooi River.

"On reaching the swollen river near Nourse Varty's farm, eight of the party swam across on horseback to scale the kopje.

"While doing so, the scouts, who had been sent along the river-bank, gave the alarm, and reported that the Boers were closing round the kopje to cut them off.

"They at once retreated, and crossed the river, but the horses could not climb the bank and returned riderless to the other side.

"The riders swam in and brought them back, and succeeded in dragging the exhausted animals up, when they discovered that they had been the victims of a false alarm.

"After resting, the party again crossed the river, leaving their clothes behind.

"Without a vestige of clothing, they proceeded to a height a mile off, and saw the Boers breaking up camp, and moving towards Ulundi Road.

"The naked party remained watching for an hour and a half, when Simmons recrossed the river and came back to camp to report the news, leaving Gough to report the enemy's further movements."

Here it must be mentioned that General Hildyard spoke most highly of the members of the Rifle Association and of the admirable scouting done by them. He said also that great credit was due to Captains Symonds and Ross and their officers for the wonderful efficiency which they had displayed.

From the accounts received of the battle that took place outside of Estcourt while that village was shut off, it was believed that Boer women had come to help their lords to smash the "verdomde rooineks." Those who are well acquainted with the Boers suggest that their ladies were brought upon the scene to act in the place of white flags, for certainly in the storming of Beacon Hill one of our officers ceased to fire because he was confronted with a woman. Others declared that they formed a portion of a trek which had come to implore the Boer generals to

cease the war. As we all know, the Boer women in ancient history—such ancient history as the trekkers have—egged their husbands and fathers on to warfare, loading their guns for them, and even firing themselves when needful; therefore the idea of their being desirous of peace was improbable. It is possible they would scorn to treat the petticoat in the light of a white flag, and prefer to stand side by side with their mates in their thinning ranks.

The Boers now entirely vacated their position along the Highland range of hills, owing, it was believed, to the River Mooi being in flood, and also in consequence of a smart engagement that had taken place with General Hildyard's troops. Ladysmith remained calm, and though there was some cannonading, it evoked no response. The Boers congratulated themselves that the days of Ladysmith were numbered, that another week would find them in possession of the place, and, though no great humourists, they indulged in mild witticisms, christening their big guns "Suzerainty" and "Franchise." The besieged meanwhile consoled themselves. Their position was stronger than ever, having been made so with redoubts and breastworks, and they awaited the coming of Sir Redvers Buller and his forces with cheerfulness and confidence.

[Pg 141]

On the 26th of November the British troops began to advance on Colenso, marching from Estcourt to Frere, where they found that the railway bridge had been destroyed. The lines, however, were rapidly repaired. By this time all had learnt to look cautiously out for the derailing of the trains, and Kaffirs with flags were posted at points in the line to signal if danger were ahead. Another contingent of the Naval Brigade from Her Majesty's ship *Terrible* started from Durban with guns and special mountings invented by Captain Percy Scott. The officers in command were Commander Limpus, Lieutenants Richards, Wilde, and England. Surgeon Lomas accompanied them.

The new gun-carriage designed by Captain Percy Scott at this time came in for a great share of attention. The feature of the invention is a spade which holds the gun in position, while the recoil is absorbed by the compression of oil and springs. Great strain is thus placed on the spade, and consequently its success depends largely on the character of the soil and the hold obtained.

On this subject a correspondent writing to the *Times* from Natal said:—

"You may be interested to hear a little about the Navy, who have come to the front as usual and met an emergency. From the first it would seem that what was wanted were long-range guns which could shell the enemy at a distance outside the range of their Mauser rifles, and the captain of the *Terrible*, therefore, proposed a field-mounting for the Naval long 12-pounder of 12 cwt., which has a much longer range than any artillery gun out here. A pair of waggon wheels were picked up, a balk of timber used as a trail, and in twenty-four hours a 12-pounder was ready for land service. Captain Scott then designed a mounting for a 4.7-inch Naval gun by simply bolting a ship's mounting down on to four pieces of pile. Experts declared that the 12-pounder would smash up the trail, and that the 4.7-inch would turn a somersault; the designer insisted, however, on a trial. When it took place, nothing of the kind happened, except that at extreme elevation the 12-pounder shell went 9000 yards and the 4.7-inch (lyddite) projectile 12,000 yards. Captain Scott was, therefore, encouraged to go ahead, and four 12-pounders were fitted and sent round to Durban in the *Powerful*, and also two 4.7-inch guns. People say here that these guns saved the situation at Ladysmith. A Naval friend writing to me from the camp says: 'The Boers complain that we are not "playing the game"; they only expected to fight rooineks, not sailors who use guns that range seven miles, and they want us to go back to our ships. One of our lyddite shells went over a hill into their camp, killed fourteen men and wounded thirty. Guns of this description are not, according to the Boer idea, at all proper, and they do not like our way of staggering humanity. Had these guns been landed earlier, how much might have been saved? It is a peculiar sight to see the 4.7-inch fired. Many thought it would turn over, but Captain Percy Scott appears to have well calculated the stresses; there is with a full charge of cordite a slight rise of the fore end, which practically relieves all the fastenings. Hastily put together, and crude as it looks, it really embraces all the points of a scientific mounting, and it wants a great expert to pronounce an opinion on it. The gun is mounted so high that to the uninitiated it looks as if it must turn over on firing, but it does not, and the higher angle of elevation the less strain there is on it. The arrival of our guns practically put the Royal Artillery guns out of use, for they can come into action 2000 yards behind those supplied to the soldiers and then make better practice. Their arrival has, every one admits, quite changed the situation.'

[Pg 142]

"Captain Scott has also rigged up a searchlight on a railway truck with a flasher attachment, the idea being to use it for communication with Kimberley and Ladysmith if these places are surrounded. It has been tested at a distance of forty miles, and proved a great success. I am told, too, that he is now engaged in designing a travelling carriage for a 6-inch gun, and has, indeed, converted the *Terrible* into a factory for curiosities in gun-mountings.

"Each mounting, by the way, has an inscription upon it, presumably concocted by the ship's painter. One, a parody upon the Scotch proverb, runs, 'Those who sup with me will require a devil of a long spoon'; another, 'For what we are going to receive may the Lord make us truly thankful—Oom Paul'; and a third, 'Lay me true and load me tight, the Boers will soon be out of sight.' I saw one of these guns fired with an elevation of 24 degrees and a range of 12,000 yards, and fully expected to see the whole thing capsize, but it hardly moved. After the firing of several rounds I carefully examined the mounting, and noticed that, crude as it might appear, a wonderful amount of practical knowledge was apparent in its construction; the strain was beautifully distributed, every bolt and each balk bearing its proportionate share. It is in every way creditable to the navy that when emergency arises such a thing could be devised and made

by the ship's engineering staff in twenty-four hours."

While the brigade was pushing on to the front, General Joubert was falling back, with a view to disputing the passage of the Tugela River. He was believed to be concentrating three corps—one on Ladysmith, one on the Tugela, and one to east of Maritzburg.

As the scene of the armoured train disaster was only about two miles from Frere camp, several of the officers rode out to look at the wreckage of the machine. The trucks were still lying on the line, a most lamentable evidence of shock and collapse. One armoured truck was off the metals, two unarmoured trucks were also overturned, one containing the platelayers' tools standing on its head, wheels uppermost, in a state of melancholy abandonment. All the trucks were mute witnesses to the fierce fire to which the train and men had been subjected. Shell-holes were here, there, and everywhere, and the iron was ripped up and rent as though it had been matchwood. The spring of one of the waggons had been blown into space, and the Naval gun which was posted on one of the low-sided trucks must have gone with it, for no trace of its existence remained. The method of derailing the train had been simple. A railway metal had been arranged across the lines with stones at the end to weigh it down and keep it from being pushed clear. Besides this, fish-plates had been loosened, and stones put under the rails. Round the scene still lay helmets and remnants of clothing, many of these being blood-stained and ragged.

[Pg 143]

At Estcourt all was quiet. Farmers were returning to their homes and provisions streaming in. Much satisfaction was displayed at the arrival of some 500 cattle and sheep which the Boers had apparently looted and left behind them.

With Lord Methuen's advance in the west and General Buller's arrival in the east the campaign may be said to have begun in earnest. The Boer programme in a fashion seemed to have collapsed; the support of the Cape Dutch, on which it had relied, was not forthcoming. The idea of the Republics was to consolidate themselves and capture Natal, while minor forces were to blockade Mafeking, Vryburg, and Kimberley. This latter place was to be the rallying-point of the Cape Dutch. But fortunately the Cape Dutch did not see it. They did not rise to time and cut off all the railway systems, and Lord Methuen in his part of the world was too active in bringing up his advance to allow for the development of any nefarious schemes which might have been on the tapis. In face of this disappointment and this advance, the Boers had to gather themselves together. They had no reserves to send down to the assistance of their forces in the southern borders, and could only assist these by withdrawing men from commandoes already in the field. As a natural consequence, therefore, certain commandoes had to be withdrawn from Mafeking and Kimberley. In Natal all watched the forward march of the British with eager eyes. The Boers, hampered by a long train of waggons, captured cattle, and miscellaneous loot, had been headed off at the only point on the Tugela where a crossing, since the heavy rains, could be effected. It seemed, therefore, that Fortune had twisted her wheel, and that before long the prospects of South Africa would be brightened, and the remembrances of eighteen years would be entirely sponged out. Rumours were afloat, however, that the Boers were concentrating in their old positions near Colenso at the back of Grobler's Kloof, and everything pointed to the fact that a last determined effort would be made to prevent the British from crossing the Tugela.

[Pg 144]

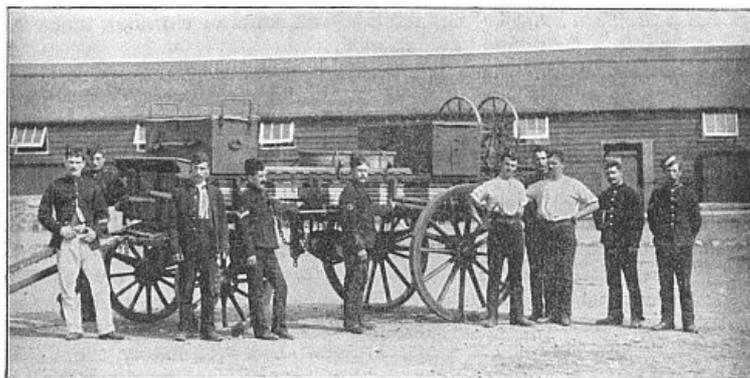

TELEGRAPH SECTION OF THE ROYAL ENGINEERS.

PHOTO BY ELLIOTT & FRY

In spite of the success of our flying column in driving the foe back across the river, there was cause for regret that the distance was too great to allow of our bringing up guns and reinforcements in time to save the bridge from destruction. But the distance from Frere to Colenso was considerable, and roads were so heavy that the dragging of guns from one place to the other would have meant a stiff day's work. There was apparently no option, the Frere bridge being broken, but to let the enemy destroy the Colenso bridge, invaluable as it was. It became very evident that the enemy meant to fight tooth and nail, and that the passage of the Tugela would be disputed inch by inch. However, none was dismayed: all believed that when the great tug-of-war should come, they would be equal, and more than equal, to the occasion. Indeed, now that the forward movement of the troops had commenced, the camp was animated by a wave of patriotic fervour. The men were literally on fire with enthusiasm. They longed to press on and come to some distinct turning-point in the history of the campaign.

A word must here be said of the splendid work done at this time by the irregular mounted troops, about 700 in number. Their value in all manner of ways was continually being demonstrated. This



**SERGEANTS OF THE ROYAL HORSE ARTILLERY
WITH A 12-POUNDER.**

Photo by Gregory & Co., London.

The Boers were now energetically preparing a warm reception for General Buller. Small parties were found in the neighbourhood of Chieveley, and these were endeavouring to post their long-range guns in convenient positions for the defence of the river. They were not destined to have things entirely their own way, however, and were promptly engaged by the Imperial Light Horse and forced to retire. This they did to the tune of a tremendous explosion, which could be heard for miles off. It was caused by the blowing up of the Colenso bridge, for the purpose of impeding our possible advance. The iron bridge over the Tugela River had previously been rendered a hopeless wreck. The number of Boers round Colenso at this time was said to be about 15,000, with some 15 guns. At Frere camp our troops numbered about 3500, and at Estcourt there were about the same number, but reinforcements were expected.

SURPRISES AT LADYSMITH

At Ladysmith, St. Andrew's Day was duly kept by the Gordon Highlanders, and Scottish compliments, appropriately seasoned with whisky—now getting tragically scarce—were passed round. Sir George White dined with the gallant regiment. Now that the town was in heliographic communication with Sir Redvers Buller, and military intelligence was received regarding the movements of the relieving force, there was a general sense of security among those who had been incarcerated so long. The Ladysmith force under General White's command amounted to a total of some 12,500 troops, and these, could they once get free and join the force, numbering about 20,000, at Sir Redvers Buller's disposal, would have made a sensible difference on the fortunes of Natal. At this time provisions were fairly moderate in price, meat being one shilling a pound and bread fourpence a pound, but luxuries, liquors, &c., were growing scarce. For instance, a tin of milk—the last in Ladysmith—fetched three shillings, and eggs were purchasable for six shillings a dozen. The military authorities had commandeered all eatables, arranging that bread and meat should be sold at prices fixed for all. The health of the troops was kept up by athletic exercises, and the officers at times played polo. The bars at the hotels were closed, but mineral waters were obtainable. Horses began to look lean, though oats and mealies, bran and hay were forthcoming in sufficient quantity; but of pasturage there was little. The Boers made great efforts to shoot the cattle, thinking that though they might not storm the garrison they might starve it to surrender. Very few newspapers were smuggled into the town, and these were rapturously seized and devoured. Life was monotonous and a little sickness began to be apparent, many of the cases arising from using the muddy water of the river.

[Pg 146]

It was now discovered that the fashionable entertainment of the Dutch ladies was to take special weekly trains from Pretoria for the purpose of joining the Boers on the hills outside Ladysmith and inspecting the unhappy town. The forces surrounding the place were commanded by Schalk-Burger and Louis Botha, who doubtless, with Pretorian dames, were the heroes of the hour.

On Sundays Divine Service took place in the Church of England, the Congregational minister's house, and in the Convent, all these religious devotions partaking of a particularly solemn and earnest character. Every man stood, as it were, with his life in his hands before his God, and week after week it was impossible to say which of the devout flock might be missing, and have gone out into the invisible to solve the *grana peut-être*. There was a pathetic atmosphere surrounding these religious meetings that none who joined in them will ever forget.

On the 8th of December a very brilliant operation took place at Lombard's Kop. General Hunter, with a hundred picked men of the Imperial Light Horse under Colonel Edwards (5th Dragoon Guards), and five hundred Natal Carabineers under Colonel Royston, started from Ladysmith camp about nine o'clock on the previous night. Four abreast they marched from the outpost and faded in the gloom. The march lay across a stony, rugged plain, through the scrub of mimosa

bush and among dongas deep and shallow. Close on the heels of Major Henderson and several of the Corps of Guides the troops pressed on. About ten o'clock they reached the base of the hill under Lombard's Kop, and there took up a position. While still pitch dark—two o'clock in the morning—they began to advance on their perilous enterprise, climbing up steep and slippery slopes, and stumbling over boulders, and tripping on loosened stones. The stars blinked, the sky seemed slumbering in one vast dream of blue. Stealthily they moved with the footfalls of tigers stalking their prey. Not a word was spoken. Scarcely a breath drawn.

Above, on the flat top of the hills, were the objects of British desire—the Boer guns. A 6-inch Creusot, throwing a 94-lb. shell, and a 4.7-inch howitzer, firing a 40-lb. shot. More anxious than sweetheart for the sight of his lady-love were these gallant fellows for the touch of these treasures. Up they went, each outracing the other, straining every nerve and muscle to gain the summit of the hill, to be first to handle the prize!

At last, when about half the distance had been cleared, they were challenged by the picket. "Wie gaat daar?"—"Who goes there?" he sang out in alarm. It was a thrilling moment. To the challenge there could be but one reply. That reply they gave. Shots rang out in the darkness. There was now no more creeping. Tongues of flame darted from every side. The troops pushed forward in the grey mysterious gloom to the ping of bullets that whizzed in shoals swiftly past their ears. Major Henderson dropped. More bullets rained down. A Guide fell wounded by cycle bearing-balls shot from a rifle—so it was subsequently said. One gallant fellow after another threw up his arms dying or dead. But still the troops pressed on, Colonel Edwards in advance shouting them on to victory. "Fix bayonets," he called with a voice of thunder, knowing there were but four bayonets among the lot. "Give 'em cold steel," shouted some one else with delirious rapture, and the Carabineers and Light Horse, with scarce a bayonet to their name, cheered and charged! But the Boers delayed not to find out if there were steel or no steel. They fled in dismay, leaving behind them their cherished guns. So swift indeed was their flight, that hats, boots, letters, everything—were scattered to the winds.

[Pg 147]

Thereupon Captain Fowke and Lieutenant Turner, R.E., with great skill destroyed a 6-inch gun and a 4.7-inch howitzer with gun-cotton. They also captured a Maxim. This magnificent piece of work, counting from the moment the order to charge was given, was performed in three-quarters of an hour, with the loss to our troops of only seven men. The conduct of the Imperial Light Horse was superb, and Major Edwards was the first man in the embrasure. The following is an account of the destruction of the guns given by the war correspondent of the *Standard*:—

"In order to give the rest of the force time to complete its work, Major Edwards, who was the first man to set foot on the summit, led his men of the Imperial Light Horse to the far side of the hill, and poured volleys in the direction of the Boer retreat. Some of their vedettes could be seen hovering about, but they were evidently too demoralised to approach us closely.

"Meanwhile, the Volunteers and Sappers were making a hurried search for the big guns. For a moment the horrible thought seized us that there might be no guns at all—that the enemy, as has so often been the case of late, had somehow got wind of the projected attack, and had removed the cannon to a safe distance. But at last, to the delight of everybody, 'Long Tom' itself was discovered, snugly ensconced behind a parapet of sand-bags no less than 31 feet thick. A 4.7-inch howitzer was found in an emplacement hardly less strong, with a Maxim gun between the two—posted there, apparently, for the purpose of repelling any such assault as the one we had actually delivered.

"Lieutenant Turner, with a party of two sappers and six artillerymen, at once took charge of 'Long Tom,' and, getting to work with crowbars and hammers, smashed the breach and elevating gear. Two charges of gun-cotton were then placed in the breech and muzzle and connected with fuses. While 'Long Tom' was thus being provided for, similar attentions were bestowed on the howitzer by Captain Fowke and the other sappers and gunners.

[Pg 148]

"The preparations being complete, General Hunter ordered the men to make their way back down the hill, and the fuses were set light to with the burning ends of the officers' cigars. Everybody fell back, with the exception of Captain Fowke, who remained midway between the big guns, and, after a couple of minutes' suspense, a loud report showed that our object had been accomplished. Captain Fowke hastened to examine the *débris*, and found that the 6-inch gun had two gaping holes in its muzzle, which was badly bulged, and that the breech and rifling had been destroyed beyond all chance of repair. The howitzer was in an even worse plight, the explosion having wrecked the carriage as well as the gun."

The force under General Hunter was composed of a hundred men selected from three squadrons of the Imperial Light Horse: Squadron B, Captain Mullens; Squadron E, Captain Codrington; Squadron F, Captain Fowler; Commanding Officer, Colonel A. H. M. Edwards, of the 5th Dragoon Guards, with Major "Karri" Davis, and Captain Fitzgerald, Adjutant of the Regiment. The second hundred men were chosen from the Natal Volunteers, and were led by Major Addison. The flanking parties, under Colonel Royston, were composed of Natal Mounted Rifles, under Major Evans; Border Mounted Rifles, under Major Rethman; Carabineers, under Colonel Greene; and Natal Mounted Police, under Inspector Clarke; Colonel Royston in command. Major Henderson was in charge of the Guides. Our casualties were nine wounded, one mortally.

A little later in the day a smart skirmish commenced between Colonel Knox with one squadron of the 19th Hussars and the Boers on Pepworth Hill. The enemy thinking that all the troops had been engaged, to their discomfiture, near Lombard's Kop, arranged that they would seize the opportunity to approach the town. Again they were somewhat surprised to find Colonel Knox and his party in readiness for them. Some brisk fighting ensued, but all was over by six o'clock, and the net result of the morning's work was considered highly satisfactory. The voice of "Long Tom" was completely silenced, and Ladysmith had got a Maxim to the good. The Boer telegraph lines

were cut and their kraals burnt. On the whole, the troops were well pleased with themselves, and returned to receive an enthusiastic reception from those within the town. The only regret was that Major Henderson, D.A.A.G., 1st Argyll and Sutherland Highlanders, should have been wounded in two places.

Probably this was the first time in the history of British arms that guns have been stormed by Mounted Infantry, and the complete success of the movement reflected the utmost credit, not only on the troops themselves, but on Major-General Hunter, who so magnificently led the assault. After the men returned to camp, General White had the Volunteers, Light Horsemen, and other portions of the force paraded, and addressed them as follows:—

[Pg 149]

"Colonel Royston, officers and men of the Natal Mounted Volunteers, officers and men of the Imperial Light Horse, and officers and men of the Imperial Forces,—I have heard the details of last night's work from Major-General Hunter, who so ably planned the undertaking and carried it out. He has asked me to express to you his appreciation—and deep appreciation—of the admirable manner in which you supported him in it throughout. It is a great pleasure to me that I am here, not only to acknowledge the fine work you did last night and your valuable services, but also as I was longing for an opportunity of acknowledging the value of your services since this campaign commenced. I am glad to think that the very important service rendered last night was got through with so few casualties. It will be a great pleasure to me to report to General Sir Redvers Buller, whom we all hope to see in a few days, the good behaviour and great help we have had from the Natal Volunteers, who, I may say without any inflated or exaggerated language, are a credit, not only to their own Colony, but to the Empire. We I daresay, have a lot of severe fighting before us, and it is a great gratification to me to know I have the help of such men as I see before me. I know you had a bad night last night and are needing rest, but I thought you would not, perhaps, mind my turning you out to tell you how all the officers of this force appreciate your behaviour, and I hope you will keep it up to the end. Colonel Royston, I won't keep the parade any longer."

Hearty cheers were given for General White, Major-General Hunter, and the Queen.

General White also addressed the Royal Engineers and Artillery, stating that all praise was due to the officer in charge for the able manner in which he had performed his duty, and to the men for the steadiness with which they had assisted individually.

General White visited the I.L.H. camp, inspecting the corps on parade, and expressed himself in similar terms to those used to the Volunteers.

Doubtless the success of the last midnight sortie roused a spirit of emulation in the breast of the gallant besieged, for another daring manœuvre was secretly planned. It was decided that an effort should now be made to destroy an inconveniently active 4.7-inch howitzer which was posted on a height appropriately termed Surprise Hill. When the shades of night began to fall, five companies of the Rifle Brigade, with an Engineer detachment in charge of Lieutenant Digby Jones, R.E., started off from King's Post on their dangerous mission. The moon, however, shone clear and white, throwing undesirable magnesium light over their progress. It was a night for Hero and Leander, not for deeds dark and deadly. For this reason they halted at the base of Observation Hill until such time as it was possible to proceed in safety. Presently the moon sank behind clouds and they moved on. At half-past one they crossed the railway lines and commenced, stealthy as cats, to ascend the hill. One company and a half was left on the right, and one company and a half on the left flank. A half company was posted in a nullah near the railway. The remainder of the force, led by Colonel Metcalfe, deployed into line and ascended with steady, cautious step. The Boer picket was evidently dozing, as the party was never challenged till the British had almost reached the top of the hill. Then, with a sudden surprised "Who goes there?" and a leap to arms, the enemy fired several shots. Directly afterwards, the order to "Fix bayonets" was given. This was followed by the click of steel and the rush of our men wildly cheering—cheering till the midnight echoes rang with weird reverberations. The crest of the hill was carried! The Boers, after firing a few shots, had vanished into space.

[Pg 150]

After some moments of anxious search the gun—the object of the British operations—was found. It was promptly surrounded, and the breech-block and muzzle were destroyed with gun-cotton by Lieutenant Digby Jones, R.E. The fuse unluckily declined at first to ignite, causing the delay of some twenty minutes, during which interval the Boers, reinforced, had swept back round the kopje and sandwiched themselves between the attacking force as they retired down-hill and the reserves. The confusion that ensued was lamentable, as the fighting line were forced to cut their way through with the bayonet, but this with extreme caution, as in the darkness it was difficult to distinguish between friend and foe. The Boers cunningly enhanced the difficulty of the position by passing themselves off as British, and repeating our cries and orders, and calling "Is that the Rifle Brigade?" &c. On receiving an answer they promptly fired, our reserve being unable to make return owing to a fear of injuring our own force. The Boers' losses were great. Our own were: Lieutenant Fergusson, 2nd Rifle Brigade, and ten rank and file killed; Captain Paley, Second Lieutenant Davenport, Second Lieutenant Bond, and forty rank and file wounded. Six men of the Rifle Brigade who remained in charge of the wounded were taken prisoners.

Sir George White now continually used his balloon for purposes of observation. He was also in communication with Frere Camp, where an electric searchlight was in operation, and with Umkolanda, near Weenen, where Captain Cayzer of the Dragoons worked the heliograph.

The garrison still remained cheerful although the Boer bombardment grew heavier. Threatening sounds of firing in the neighbourhood of Colenso caused them to sustain hope, though the pinch of siege life, suspense, sickness, and shell-fire were beginning to be felt. However, owing to the admirable forethought of Colonel Ward, Army Service Corps, the food supply was still equal to

FRERE CAMP

General Sir F. C. Clery arrived at Frere on the 2nd of December, and assumed command of the Second Division. He took up his quarters at the shattered house of the stationmaster. Preparations were set on foot to repair Frere bridge, which had been entirely wrecked, and a mounted force under Lord Dundonald was actively engaged in chasing large parties of Boers on their return to Colenso. Great interest was caused by the arrival in camp of another of the inventions of Captain Scott of the *Terrible*. It consisted of a searchlight apparatus for signalling to Ladysmith, with engine and dynamo, entirely armoured. Communication with Ladysmith by heliograph was soon successfully established, much to the consternation of the Boers at Colenso, who tried their best to interfere with messages. The camp was daily increasing in size, and reinforcements, with their baggage, horses, waggons, and guns, began to pour in from Maritzburg, while the Durban Light Infantry and a battery of Natal Field Artillery were posted to protect Estcourt, Willow Grange, and Mooi River from raiders and attacks on lines and telegraph wires.



**FROM FRERE TO CHIEVELEY—
DIFFICULTIES OF TRANSPORT.**

Drawing by R. Caton Woodville.

The arrival of Generals Buller and Clery and the increasing concentration of troops now began to presage an important and, it was hoped, decisive movement. Visual communication was being held nightly with General White, and a combined action seemed quite possible. It was recognised, however, that the Boer position at Colenso could not be taken by direct frontal attack, and that some arrangement to turn the left of the enemy must simultaneously accompany a demonstration in front. Mounted troops had now joined the British forces, and there was every hope that the Dutchmen, once routed, could be pursued and kept on the run. But so far the Boers were unconcerned; they seemed to be in fine fettle, and even indulged in humour at the expense of the British garrison. When the heliographers questioned the enemy, "Are you Boers?" they replied, "Yes." They were then asked, "Where are you going?" and bounced back, "To Maritzburg." "God help you," said we. "We think He will," they devoutly replied. They also indulged in compliments of a less righteous description, finishing up with the crude and scarcely eloquent expression, "Go to h—ll." But, as a mild diversion, Boer humour was accepted, for, in the routine of the soldier's existence, the smallest mercies in the form of distraction were thankfully received. Life just then, even for the officers, was not roseate—the messes had a ubiquitous menu of bully beef and bread, and the mess-tents were made of the tarpaulins of the big mule-waggons. Repose was a beautiful name. The torture of sleeping on a valise on the ground for weeks at a stretch was—so an officer declared—much the same as that produced by some beds in Irish inns—after lying down for some hours, you have to get up and take a rest!

[Pg 152]

Meanwhile, Provost-Marshal Major Chichester, at Frere Camp, distinguished himself. On the 7th of December he started off with thirty men of the Natal Carabineers and a few Mounted Police for the purpose of arresting three colonists suspected of aiding the enemy. They left camp for the Gourton district at about 5 A.M., and marched through the country beneath the snow-capped Drakensberg Mountains some fifty miles. There the landscape is picturesque and beautiful as any in Natal; but their object was not to admire scenery, but to pursue traitors. At a small farm they came upon the objects of their search. The miscreants were promptly seized, together with their loot, some 150 head of cattle. With these the party started to return, but were fired on by six Boers from a neighbouring donga or ditch. Major Chichester then ordered forward part of his troop with the prisoners in charge, while he and the rest of his men held the enemy at bay. A brisk fusillade ensued, in which five of the enemy's ponies were killed, and several of the Boers were shot. The party returned to camp safely, after having accomplished the object of their expedition in the space of twenty-three hours.

The trestle bridge at Frere was now completed, and trains began to run over it. Frere Bridge, on the Natal Government Railway, some twenty miles from Ladysmith, was, it may be remembered, the first to be blown up by the Boers on their retreat from Estcourt to Colenso.

The following is a rough list of the force, under General Sir Redvers Buller, Major-General Sir C.

F. Clery, Major-General Hildyard, and Major-General Barton, which was now advancing towards Ladysmith from Durban by way of Pietermaritzburg, Mooi River, Estcourt, and Colenso:—

1st Border Regiment, 2nd Royal Dublin Fusiliers, 2nd West Yorkshire, 2nd East Surrey, 2nd West Surrey, 2nd Devonshire, 1st Welsh Fusiliers, 2nd Scottish Rifles, 2nd Royal Fusiliers, 2nd Royal Scots Fusiliers, 2nd Royal Irish Fusiliers, 1st Royal Dragoons, 1st Durham Light Infantry, 13th Hussars, 1st Connaught Rangers, 1st Dublin Fusiliers, 1st Gordon Highlanders, 1st Inniskilling Fusiliers, 2nd Somersetshire Light Infantry, 3rd King's Royal Rifles, B Squadron 6th Dragoon Guards, one Squadron Imperial Light Horse, Durban Light Infantry, various Local Rifle Associations, Naval Detachments, Volunteer Cavalry and Infantry, Uitlander Corps under Major Thorneycroft, 7th, 14th, 64th, 66th, 73rd Field Batteries, several Companies Royal Engineers, several Companies R.A.M.C., Field Hospitals.

Besides the arrival of incoming regiments, camp life at Frere was enlivened by many minor episodes. Provost-Marshal Major Chichester paid more surprise visits to Dutch farms whose owners were suspected of aiding the enemy. Though looting was strictly forbidden, some of the raiding parties returned with interesting souvenirs of their expeditions—sometimes in the form of corpulent turkey, squeaking sucking-pig, or other dainty with which to vary the monotony of camp fare. Good-nature prevailed among the troops, and the health of the men testified to the excellence of their feeding. Fair beef, occasional mutton, and beer were available, and with these at hand and the enemy in front, and shortly to be interviewed by heavy guns plus the bayonet, "Tommy" was well content. Meanwhile, reinforcements continued to come up from Maritzburg in all haste. The march from thence to Balgowan made the first twenty-five miles. On to Nottingham Road made another ten. After a halt they took another twelve miles stretch to Mooi River. To Estcourt was twenty-four miles over fresh and verdurous country, and to Frere Camp was another fifteen. The troops, as a rule, were on the move about three in the morning, for it was now the Cape summer, and as much toil as possible was accomplished before the sun was up. Striking tents, loading waggons, feeding and watering horses, swallowing breakfast, took place in twilight, and then they proceeded to saddle up and march. Arrived at their destination, the troops off-saddled, attended to the horses, pitched tents, and performed other camp duties. Rations consisted of bread, tea, coffee, sometimes meat and potatoes. Water was a luxury, and so little was wasted for external application that several troopers offered to play the part of Othello without any make up. The war kit of the men was somewhat of the Christmas-tree order. On them were haversacks containing food, horse-brush, currycomb, and towel, water-bottle, bandolier with fifty cartridges, waistbelt and gun weighing ten pounds. Often as not they turned in to rest, if not exactly thus equipped, at least booted and spurred, ready to be up and doing at a moment's notice!

[Pg 153]

On the morning of the 14th of December the troops advanced from Frere to Chieveley. Reveille was sounded at 3 A.M., and soon the camp was one buzz of active life. In the warm glow of camp-fires tents were struck, kits packed, horses fed and watered, and the men breakfasted. Four regiments of infantry "fell in" and moved out from the camp, followed at intervals by other arms. The procession measured some eight miles long, and was composed of variegated objects, such as ambulance waggons dragged by innumerable oxen, mule and donkey carts, the teams and guns of six field-batteries, cavalry and infantry, and hale and hearty Jack Tars, looking very ship-shape, square and determined, and joking as though they were off to a ball. All were equally jovial, all confident that the big move was begun, and a big and glorious ending was in store.

[Pg 154]

The entire force encamped three miles from the Tugela River to north-west of Chieveley Station; the Infantry Brigades being on the extreme front, while the Cavalry, Mounted Infantry, and Artillery were nearer to Chieveley. Soon after this the Naval guns set to work to search the intrenchments and positions of the enemy north of Colenso. These guns, consisting of two 4.7-inch and four 12-pounders, were posted some 3000 yards south of the Tugela, about three miles from Colenso village, and facing what was afterwards discovered to be the Boers' position. Their bark resounded over the kopjes for miles, throwing up gigantic volcanic eruptions, which resembled mammoth mushrooms suddenly springing to life. But beyond filling the hearts of hearers with awe, they produced no result. The Boers were silent, so silent indeed that some imagined that they had vacated their positions and that the passage of the Tugela would after all be quite a frolicsome picnic, with perchance a few crackers thrown in. All were deceived—even those well acquainted with Boer tricks and duplicity—and all imagined that the enemy had fallen back, possibly for the closer protection of Ladysmith.

But before going further, it is necessary to keep in touch with other brave defenders of the Empire.

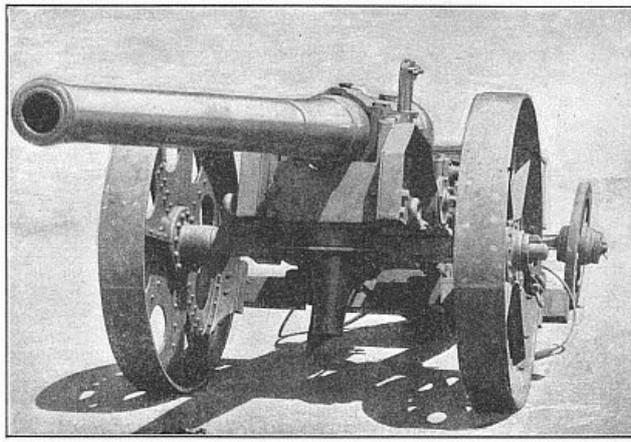

**TYPES OF ARMS—4.7 NAVAL GUN ON CARRIAGE
IMPROVED BY CAPT. PERCY SCOTT OF H.M.S.
TERRIBLE.**

PHOTO BY E. KENNARD, MARKET HARBOROUGH

[Pg 155]

CHAPTER V

ACTIVITY AT THE CAPE

Boer annexations continued with insolent persistency, and the High Commissioner, Sir Alfred Milner, telegraphed thus to Mr. Chamberlain:—

"16th November—Having been informed that Orange Free State have issued Proclamations annexing Griqualand West and portions of the Aliwal North, Albert, and Colesberg districts, I issued counter-Proclamation on 10th November and 15th November of a similar kind to that in my telegram of 28th October, and have declared latter districts to be under martial law."



**SERGEANT-MAJOR OF THE NEW
SOUTH WALES LANCERS.**

Photo by Gregory & Co., London.

At this time the British reinforcements arriving in Cape Colony were:—

3rd Battalion Staffordshire, 1st Highland Light Infantry and Mounted Infantry, 1st Battalion Scots Guards, 2nd Northampton Regiment, 2nd Battalion Royal Highlanders, part of 2nd East Surrey, 3rd

It must here be noted that among the many prominent persons who had placed themselves at the disposal of their country and were leaving for the front were Sir W. MacCormac and Mr. Makins, whose surgical skill was offered to relieve the suffering. Mr. Treves, the eminent surgeon, had also volunteered his services. The following regiments arrived at Cape Town on the 20th of November, and went on to reinforce the advance columns or to preserve the lines of communication under the command of Lieut.-General Sir W. E. F. Forestier-Walker:—

12th Lancers, one squadron 14th Hussars, 2nd Northumberland Fusiliers, 1st Royal Munster Fusiliers, four companies 2nd Berkshire, 2nd Royal Highlanders, 1st Highland Light Infantry, 2nd Seaforth Highlanders, 1st Argyll and Sutherland Highlanders, 1st Welsh Regiment, several Corps of Engineers, including Balloon Sections, Batteries, Field Hospitals, Seamen and Marines, Post-Office Corps, Railway Engineers, Corps of Light Horse (in course of formation), New Zealand contingent:—a total of about 8000 men.

The South African Light Horse, a corps formed of the Uitlanders, was being rapidly organised, and great enthusiasm prevailed among the Colonists. All were anxious to be first in the field and to display their loyalty to the Sovereign. Indeed, there was not a little jealousy lest other Colonists might debar those at the Cape from proving their devotion to the full. The new regiment started on the 30th of November for the north amid enthusiastic cheers.

[Pg 156]

Quantities of reports having been circulated and a great deal of misapprehension caused as to the policy and intention of the Government, Sir Alfred Milner issued a proclamation addressed to the people of Cape Colony. In it he said:—

"Misleading manifestoes from beyond the borders represent the Imperial Government as desiring to oppress the Dutch, and the idea has been spread abroad that the Dutch are to be deprived of constitutional rights.

"There is absolutely no truth in such allegations. The Imperial Government desires the greatest freedom of self-government for Dutch and British alike, and the extension, not the curtailment, of the above. The Constitution can solely be endangered by rebellion.

"The Imperial Government adheres firmly to the principles of equal freedom for all loyal Colonists.

"Her Majesty the Queen during her long reign has given innumerable proofs that she does not favour one race at the expense of another. All allegations to the contrary are made either in ignorance or with the deliberate intention of shaking the loyalty of a section of the community, including many connected by close ties of kinship with a people with which we are now at war.

"An attempt is being made to inflame their minds, and to convert feelings of sympathy with kinsmen into a spirit of rebellion, by representing the Imperial Government as hostile to the Dutch, and by otherwise distorting its acts and objects.

"I gladly recognise that the majority, nevertheless, maintain a law-abiding attitude, and I am proud of their worthiness of the confidence reposed in them. But the statements which continue to be spread abroad are producing a deplorable effect in some quarters, and I therefore most earnestly warn all against being misled into defection from their allegiance, and thereby exposing themselves to grave consequences.

"I call upon all the Queen's subjects, of whatever race, to stand together in support of the Crown and its authority."

But, for the treachery of some of Her Majesty's subjects, the devotion and fealty of others made glorious atonement. There are loyal people in the Cape, who, if they live to be as old as Methuselah, will never forget the opening of December. The streets of Cape Town were literally panting with enthusiasm, every hole and corner being alive with animated crowds to welcome the New Zealanders, Australians, and Canadians, gallant fellows, who, from sheer pride in being associated with the defence of the mother country, came trooping to do battle in her cause. Each successive arrival of the Colonists was the cue for fresh demonstrations and for the display of flags and banners bearing mottoes, "For Queen and Empire," "Welcome, Brother Colonists," and the like; and by the time the Canadians had landed patriotic feeling had reached its climax. Then public enthusiasm literally seemed to burst all bounds. The streets, windows, verandahs, roofs, were packed with an excited, surging, shouting, cheering throng, and the air was thick with hats, and flags, and handkerchiefs, waving a hearty welcome to our British brethren from across the seas. The Canadians, about 1000 strong, were "a sight for sair e'en," as the Scots would say, a hale, well-grown, muscular set of men, who evidently appreciated the magnificent reception that was accorded them, and who as evidently meant to earn laurels in the service of the great Queen Mother. Indeed, all the Colonial troops were remarkable for their excellent appearance, and the sight of them arriving from every corner of the earth to support the honour and prestige of the Empire was vastly inspiring. One may safely assert that such an exhibition of patriotic solidarity and power was without precedent in the world's history.

[Pg 157]

There never was such a show of fine men, said all who saw them; but—. There was a great But. We were deficient still in other ways. We had the men, but in the matter of guns we were still lamentably weak; we could not compete with our enemies. Those in power seemed to have been ignorant of, or apathetic to, the fact that the expenditure of the Transvaal Government for artillery during the previous four years had been enormous. The marvel was that our Intelligence Department should have taken no cognisance of these gigantic preparations, or that if it had, the Cabinet had not acted on its information. In 1894 £100,000 was handed over to Krupp of Germany, and the same amount to an Austrian firm. Two of the finest guns in the world were

imported in 1895. These were 48 feet long, 120 tons in weight, throwing a shell weighing 2300 lbs., and requiring 904 lbs. of powder for each discharge. Both were amply provided with ammunition, which, in addition to the great steel and iron shells, consisted of shrapnel holding 3000 balls, weighing 3½ ounces each. One of these treasures was pointed at Ladysmith, and the other was used to defend the fortifications of Pretoria.

This was not all. In 1895 Krupp received another £100,000, and field-guns of long range, which we now know too well, were forwarded, and also certain mountain and bush guns suited to high ground and hot climate. In 1896 further developments took place. Six Creusot guns were introduced, to be followed later on by eighteen more. In 1897, '98, and '99 further additions to the Boer artillery were made, and the frontier kopjes fortified, and distances marked and measured. Then were bought forty-eight rapid-fire Schneider-Canet 14½ pounders, that throw a shrapnel containing 234 bullets, to be fired 200 times per minute, with a range of 3½ miles. Maxims in plenty were invested in, as those in Mafeking and Ladysmith knew to their cost, and the Boers also secured four batteries of 12-lb. quick-firing Vickers Maxim guns, with a range extending up to 5000 yards. Four guns with a range of 1200 yards were distributed between hills guarding the Drakensberg passes, Ladysmith, and Pretoria.

[Pg 158]

With this array of guns only our Naval guns could compete. As regards horses, we were also deficient. The sea-voyage played terrible havoc with the poor beasts. Ill-luck seemed to pursue us, for on the 4th of December grievous news arrived that the *Esmore* with the 10th Hussars and a battalion of infantry on board had gone ashore at St. Helena, some 180 miles from Cape Town. Fortunately the men were rescued from the transport, but their chargers were all lost. This was a terrible blow, for at the time cavalry was almost a nullity, and operations were somewhat suspended, if not entirely crippled, owing to the lack of that arm. Indeed, Lord Methuen's brilliant operations on the Orange River had all been heavily handicapped owing to the impossibility of pushing his victories home, and at this time the one cry of the commandants in chorus was, "Oh for a Cavalry Brigade!" There was General French, a born cavalry commander, minus mounted troops; General Gatacre with his division distributed in fragments everywhere; Lord Methuen hampered as before described, all because the nation had allowed itself to slumber and drift, and put its hand to the helm too late!

As there were continual changes in the military situation, it may be as well to make a rough computation of the troops engaged in the various campaigns. In Ladysmith, Sir George White had some 9500 men, while at Colenso, Weenen, and Natal, Generals Buller and Clery had between them some 23,000. Advancing from Queenstown to attack Stormberg was General Gatacre with 6000 men, while a probable 3000—cavalry and infantry—were with General French at Naauport. In the west, advancing from the Modder River to the relief of Kimberley, Lord Methuen had less than 8000 men, and on the line of communications at Graspan, Orange River, and De Aar were some 8000 more. At Kimberley there were about 2000 troops, while with Colonel Baden-Powell at Mafeking and Colonel Plumer in Rhodesia were about 1000 men respectively. The newly-arrived Canadian contingent, numbering some 1000 men, were sent to the front to act in concert with the Black Watch and Seaforth Highlanders. Quantities of soldiers and volunteers were daily arriving, all of them in high spirits at a chance of seeing service. Among the many passengers who landed on the 11th of December was one whose zealous determination to serve his country caused not a little emotion in those who heard his story. He was a reservist belonging to the Seaforth Highlanders, who was absent when called up. He had been in France, and only arrived in England twenty-four hours after the troopship which brought out his regiment started. He therefore proceeded to Southampton, paid his passage to Cape Town, and went on to the front at his own expense.

[Pg 159]

Of course, this is a solitary example of devotion to duty, but there are thousands which might be recorded. Millionaires rushed from their palaces, from the lap of nineteenth-century luxury into sober kharki, with all its accompaniment of bully beef and muddy water; bridegrooms tore themselves from winning brides, and scurried from the altar-rails to sacrifice their lives—at that moment more precious than at any other time—for the honour of the Empire. Not only "Dukes' sons," but a Duke indeed joined in the magnificent mob who clamoured to fight for the great cause. This impetuosity of gallantry had even its comic side, for deserters came from hiding ready to face shot and shell rather than be out of it; small boys tried spurious dodges to bring themselves to "regulation" height; and many fibbed right royally as to their ages! Some even, when rejected, were found stowed away after the transports had put to sea! "Trifles these," some prosaic readers will remark. Possibly, but to others such trifles made confirmation "strong as holy writ" that the martial majesty of our mighty nation was never more grandly evident than in the declining years of Victoria's reign!

The glorious work done by Cape Colony in aid of the Empire may be appreciated in viewing the following figures, which show that nearly 6000 South African volunteers were called out for service during the month of December:—

Prince Alfred's Own Artillery, Cape Town, 120; Cape Garrison Artillery, Cape Town, 450; Duke of Edinburgh's Own Rifles, Cape Town, 1000; Cape Town Highlanders, Cape Town, 500; Prince Alfred's Guard, Port Elizabeth, 600; Uitenhage Rifles, Uitenhage, 200; Kaffrarian Rifles, East London, 400; 1st City Volunteers, Grahamstown, 500; Queenstown Rifle Volunteers, Queenstown, 300; Kimberley Regiment, Kimberley, 650; Diamond Fields Artillery, Kimberley, 120; Frontier Mounted Rifles, Cathcart, 200; Komgha Mounted Rifles, Komgha, 100; Transkei Mounted Rifles, Butterworth, 125; Xalanga Border Mounted Rifle Club, 72; Tembuland Mounted Rifle Club, 52; Engcobo Mounted Rifle Club, 47; Cape Medical Staff Corps, 200:—total, 5636.

This number only included volunteers, and did not take in the paid irregular regiments, Mounted Police, and other bodies, of which there were several thousand more. In fact, it was estimated that the Colonial levies in Cape Colony alone numbered, at the end of 1899, about 12,000 men.

The troops in South Africa early in December, apart from the force under Sir George White, were approximately the following:—

CAVALRY DIVISION (Lieut.-General French).—1st Brigade (Major-General Babington)—R Battery R.H.A., 6th Dragoon Guards, 10th Hussars, Mounted Infantry, Ammunition Column, No. 9 Field Hospital. 2nd Brigade (Major-General Brabazon)—O Battery R.H.A., 1st Royal Dragoons, 6th Dragoons, 2nd Dragoons, Ammunition Column, No. 12 Company R.A.M.C.

[Pg 160]

KIMBERLEY RELIEF COLUMN (Lord Methuen's Command).—Major-General Sir H. E. Colville's Brigade—1st Scots Guards, 1st Coldstream Guards, 2nd Coldstream Guards, 3rd Grenadier Guards. Major-General Pole-Carew's Brigade—1st Northumberland Fusiliers, 2nd Northamptonshire Regiment, 2nd Yorkshire Light Infantry, 2nd Loyal North Lancashire Regiment (half-battalion). Major-General Wauchope's Brigade—1st Highland Light Infantry, 1st Argyll and Sutherland Highlanders, 2nd Royal Highlanders, 2nd Seaforth Highlanders, No. 8 Field Hospital. Naval Brigade, G and P Batteries R.H.A., 18th, 37th (howitzer), 62nd, and 75th Royal Field Artillery, 9th and 12th Lancers, 7th Field Company Royal Engineers, Ammunition Column, No. 19 Field Hospital.

COLONIAL FORCES (in support of Lord Methuen).—Canadian Contingent, New South Wales Lancers, New Zealand, South and West Australian, Tasmanian, and Victorian Contingents.

TROOPS IN SOUTH NATAL (Lieut.-General Sir C. F. Clery's Command).—Major-General Hildyard's Brigade—2nd Royal West Surrey, 2nd West Yorkshire, 2nd East Surrey, 2nd Devonshire. Major-General Lyttleton's Brigade—2nd Scottish Rifles, 1st Durham Light Infantry, 1st Rifle Brigade, 3rd King's Royal Rifles, No. 14 Field Hospital. Major-General Barton's Brigade—1st Royal Welsh Fusiliers, 2nd Royal Irish Fusiliers, 2nd Royal Scots Fusiliers, 2nd Royal Fusiliers, Field Hospital. Major-General Fitzroy Hart's Brigade—1st Connaught Rangers, 1st Royal Dublin Fusiliers, 1st Royal Inniskilling Fusiliers, No. 10 Field Hospital Company, No. 16 Bearer Company, 2nd Somerset Light Infantry, 1st Borderers, 2nd King's Royal Rifles, 1st Gordon Highlanders, 7th, 14th, 64th, 66th, and 73rd Batteries R.F.A., 12th Field Company R.E., Ammunition Column, No. 3 Field Hospital.

IN CAPE COLONY (Lieut.-General Gatacre's Command).—1st Welsh Regiment, 1st Royal Scots, 2nd Northumberland Fusiliers, 2nd Royal Berkshire, 2nd Royal Irish Rifles, 1st Rifle Brigade, 1st Royal Munster Fusiliers, 2nd Duke of Cornwall's Light Infantry, 2nd Shropshire Light Infantry, 74th, 77th, and 79th Batteries R.F.A., Two Station Hospitals.

CORPS TROOPS.—4th, 38th, 61st, 65th, and 78th Batteries R.F.A., 4th Mountain Battery, 13th Hussars, 1st Telegraph Division R.E., 10th Railway Company R.E., 26th Field Company R.E., 1st Field Park R.E., Pontoon Troop R.E., Balloon Section R.E., No. 5 Field Hospital.

UNATTACHED.—1st Suffolks, 1st Essex.

WITH GENERAL GATACRE

By the end of November two British forces were advancing from East London by way of Queenstown to the Stormberg and Colesberg districts in the north of Cape Colony. With General French's advance we must deal anon: that of Major-General Sir W. F. Gatacre calls for immediate attention. The General had under his command what was by courtesy termed the 3rd Division, namely, 2nd Royal Irish Rifles, four companies of the 1st Royal Berkshire Regiment, a troop of the New South Wales Lancers, some companies of Army Medical Corps, Field Hospital, and Volunteer Mounted Infantry. The total was about 5000 men.

On the 28th of November he was reinforced by the 2nd Northumberland Fusiliers. His force, as we see, was none too large, for he was proceeding through country where it may be said that every hand was either openly or stealthily turned against him. For strategical reasons, and for the purpose of reassuring the British population, however, General Gatacre had decided that some sort of advance must be made. He reconnoitred in and around Molteno, and visited the outposts of regulars, irregulars, and police, and ascertained to an almost pitiful degree the slenderness of his resources should any strain occur.

[Pg 161]



**STORMBERG PASS—THE SCENE OF
GENERAL GATACRE'S OPERATIONS.**

On the 26th November the Boers occupied Stormberg, and on the 28th General Gatacre moved to Bushman's Hoek with a battalion of infantry and some mounted infantry, the main body being at Putter's Kraal. On the 29th he accomplished a smart piece of work, though any really decisive action could not be attempted till more troops arrived from the Cape. The General concentrated a force at Molteno, commandeered five trains, and secured 1000 bags of flour which were in danger of being captured by the Boers.

On the 5th December the headquarters of the 3rd Division were still at Putter's Kraal, and here reinforcements were arriving daily. Manifestations of disloyalty grew more and more prevalent throughout Cape Colony, and the spread of the spirit of rebellion around Stormberg pointed to the fact that there were deliberate designs to assist in the overthrow of British supremacy.

On the 5th of December it was decided that a forward movement must at last be made. The plan was for the column to start by train to Molteno, and from thence march to the Boer laager at Stormberg. A dash was to be attempted in the darkness preceding dawn, and the position was to be carried at the point of the bayonet.

The project was fraught with extreme risk, but General Gatacre, though fully aware that he was without the necessary reinforcements to make good a continuous advance, resolved to accept the hazard for the sake of the chance of success, and for the sake of the moral effect such success might make in a district weevilled with disaffection. The game of war is one where reputation, armies, and empires are the stakes, and needs to be played not only with science, but with bluff, and no committee of generals, not even one composed of Napoleon, the Archduke Charles, and Wellington, could have laid down any fixed theory on the art of war as practised in the Transvaal at that moment. So our officers had to watch which way the wind blew and trim their sails accordingly; and Sir William Gatacre judged that it would be perilous to delay an attack on Stormberg until circumstances seemed to be absolutely propitious. The Colonial Boers were daily joining the enemy in considerable numbers, British subjects were imploring aid to save their property from destruction, and it was imperative to make some strong move which, if successful, would immediately arrest the threatened tide of rebellion. The worst of it was that everything depended on the strength of the move, and it was exactly this strength that was wanting. The Third Division was broken up and distributed in various parts of the country, and General Gatacre was forced to make a hazardous venture with only such forces as he could muster. On all sides the same unfortunate tale of weakness could be told. Our force was so divided up that each general was crippled with the consciousness that he had no hope of getting reinforcements for some time to come. Lord Methuen, now on the extreme west, while struggling for the relief of Kimberley, had kept the Free Staters at bay with great loss to himself, and was suffering from the weakness consequent on violent strain to his resources. General French, his eye fixed on Colesberg, with a diminutive and totally inadequate force, had dodged about from town to town, keeping the enemy ever on the alert and allowing him no time to snore behind his intrenchments, and no opportunity to proceed farther in his invasion of the Colony; while General Gatacre was now about to do his best in the midst of a swarming enemy to capture Stormberg. Thus we see that at one and the same time four different battles, in the most trying circumstances, were taking place in the Transvaal, and that the flower of our army was being exposed on all sides to the murderous shells of an overwhelming foe powerfully posted in places of his own choosing—at Modder River, at Arundel, at Stormberg, at Colenso—in each of these regions the continuous thunder of guns, the gallant advance of heroes, the stubborn and courageous defence of a preponderating enemy. It is some satisfaction to think that, though from the first the British suffered from inferiority in numbers, though they were out-fought by sheer weight of the Boer commandoes and guns, still they displayed an undismayed front, and those superb fighting qualities which tradition has taught us to look for in the British race, and which the enemy, misled or self-deceived, had chosen to under-estimate. It was also a matter for congratulation that the foe, with all the natural advantages of the situation, his knowledge of every inch of the ground, his great mobility and advanced preparations, merely succeeded in repelling the British attack, and never took the initiative in attempting one single forward movement in the face of the British army. But it must be allowed our own forward moves were so stubbornly resisted, that General Sir William Gatacre, while attempting to advance, recognised that in some bold and well-conceived plan of action lay his only chance of success. Such a plan he attempted to carry out, but with deplorable results, as we shall see.

[Pg 162]

[Pg 163]

THE REVERSE AT STORMBERG

General Gatacre left Putter's Kraal and concentrated at Molteno the 2nd Northumberland, 2nd Royal Irish Rifles, and Nos. 74 and 77 Batteries of Field Artillery, with Mounted Infantry, Cape Mounted Rifles, the 12th Company of Engineers, and details—in all about 2500 men. At 9 P.M. on December 9th, began the march that was destined to be so ill-fated. The night was black, the ground was rocky, and the guide, a local policeman, from ignorance, under-estimated the distance and led the troops by a circuitous route absolutely into the teeth of the enemy. Instead of going north-east for nine miles, the men were led north-west, a detour of twenty miles. A terrible night-march this, which none who undertook it can ever forget. Tramp, tramp, through the long midnight hours, over hills and down nullahs, through rivers and stumbling over stony kopjes with bayonets fixed, in grim silence, with scarce a whisper allowed, and with never a pipe as consolation lest the scent should betray the stealthy advance. For seven long hours the force,

like a phantom procession, trudged and stumbled until they came to a small V-shaped plateau surrounded by kopjes, which, unknown to them, was fronting the enemy's position. This was on a high unscalable eminence called Rooi Kop, that jutted black against the clear grey of early morning. From here the Boers, chuckling doubtless at their own cunning, were slyly watching the approach of the party; for it was now dawn. On nearing the plateau below this eminence, the Irish Rifles, with General Gatacre and his staff at the head of the column, were greeted, to their astonishment, by a fierce tornado which was suddenly opened by the enemy on the right. Though the column was marching in fours and utterly unsuspecting of the position of the enemy, they gathered themselves together with marvellous rapidity. Following the Rifles were over a hundred of the Northumberland Fusiliers, and in the rear the artillery. In a very short space of time General Gatacre got his column into line for action, and a hot fight ensued, in which the Rifles—all honour to them!—distinguished themselves in distressing circumstances. It was not possible to recover easily from the surprise, and it was evident that the General and his men were totally unprepared to meet, and unequal to crushing, a powerful enemy in an intrenched position. Naturally the casualties were many. However, the artillery were soon climbing a small kopje on the left, while the Rifles and Northumberland Fusiliers, in skirmishing order, mounted the hill held by the Republicans. Footsore and weary with their long midnight march, they toiled up the steeps amidst a cruel hailstorm from the enemy's fire, which came pouring at the same time from three separate quarters in flank and rear. One of the almost impregnable hill-tops was gained at the point of the bayonet, but so furious became the storm of bullets that the British, now outnumbered at the rate of seven to one, were forced to retire. Meanwhile the artillery were drawing the fire of the enemy's guns and launching their shrieking shells into the fort that the Boers had constructed at the corner of the kopje. But the position was unassailable. The Boers had expected the attack, and by an elaborate system they had measured and marked off distances from their batteries—a system which could not be upset in a moment. The Dutchmen swarmed in hundreds behind excellent cover and were not to be routed. Our men, who, many of them, had been occupied the whole previous day in fatigue-work, were numb from exhaustion, dropping here and there, fainting or asleep, in the very face of death.

[Pg 164]

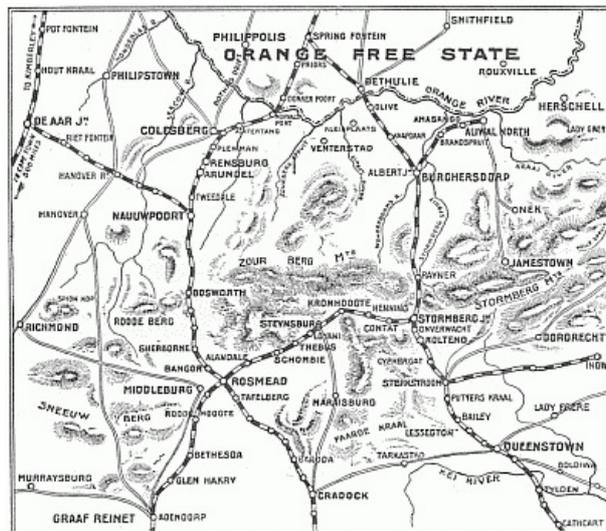

MAP ILLUSTRATING THE OPERATIONS ON THE SOUTH OF THE ORANGE RIVER

The infantry, with the Maxim detachment, were then ordered to retire towards Molteno, while the artillery remained to cover the retreat. But the retirement was not so easy. The triumphant Boers now brought their guns to the tops of the kopjes, and sent shell after shell to catch the troops as they slowly wound along the valley. Many of the shells burst with terrific force, ploughing up the roadway around our men, and shooting clouds of blinding dust into eyes and ears and throats, but fortunately doing little damage. The Boers also brought their rifles to bear on the little force, and our worn-out troops suffered the horrible experience of being hunted like hares along roads through which they had so laboriously, so hopefully, toiled the night before, tramping the weary ten miles to Molteno with the enemy taking long shots at them from innumerable points of vantage. Their progress was necessarily slow, for sometimes they had to hide in cornfields, to crouch among boulders, and occasionally to fall prone to earth when shells came screaming and bursting along their line of route. Afterwards they would rise again, still holding their life in their hands, and plod on in the expectation that every step would be their last. For eight long miles this exciting form of torture was experienced, numbers of the poor fellows dropping all along the road from wounds, exhaustion, and from the effects of the now fiercely blazing sun. Terrible was their plight both during the attack and after it, for the Boers, as usual, paid no heed to the sacred demand of the wounded or of the white flag, and no sooner saw a party of stretcher-bearers approach to pick up a man than they made the event the signal for a volley. All, therefore, that could be done for those stricken down was to wait patiently till they could crawl a short distance out of the line of fire and swoop down on them and bear them hastily away. The unfortunates who were too severely wounded to so crawl, and those who were killed, had to be left where they fell. Nor did those who were successfully removed in the ambulance waggon fare much better, for this was fired on continually, but luckily, owing to the shells not bursting, caused more horror than harm.

[Pg 165]

They reached Molteno at last in safety, but with numbers woefully thinned. When they formed up for the roll-call, the ominous silence that followed the call of name after name was more than tragic. Dismay blanched every face. Where were the 366 splendid fellows of the Northumberland Regiment who had started out in rude health only the night before? They were missing, perhaps dead! Where, too, were the roistering, cheery boys of the Royal Irish Rifles—some 294 of them—none of whom, when his name was spoken, was there to give back the word? They too were missing, perhaps dead! In this hour of mute regret those who were left could only thank God that they had come safely through the terrible ordeal, and think with awe on the strange workings of fate that had caused some to be taken and others left.

[Pg 166]

Naturally enough after a disaster so great, all had something to say of the mistakes which brought it about. Reuter's correspondent declared that "the primary and greatest mistake made on the 10th inst. was that what was to have been at the utmost a four hours' night-march lengthened out to over seven hours, and landed us right into the enemy's position in broad daylight. Of course, the guides went wrong, took the force a roundabout way, and are accordingly blamed. But how is it that our leaders, knowing that four hours should suffice to take them to their objective, should have wandered on for seven without suspecting that something was radically wrong? Then, also, at the end of that time our troops walked, in daylight, in a column four deep, right under the enemy's nose. No scouts or skirmishers were out, and it was here that we lost so heavily, the Boers from covered positions firing volley after volley right into the mass of men below. Again, the men, most of whom had been on duty since 4 A.M. the previous (Saturday) morning, were tired and hungry, and yet were asked to storm the position without rest immediately after a long and tiring night-march."

The *Times* correspondent attributed some of the misfortune to the fact that "the Berkshire Regiment, by whom the redoubts now occupied by the Boers at Stormberg had been built, and to whom every inch of the ground was familiar, were left at Queenstown, instead of being employed to recapture the works which they had so unwillingly evacuated about a month previously. The consequence of no one knowing where he was going or what he had to attack or when proximity to the enemy had been reached, was that the infantry, marching in fours, were suddenly fired into at a point where, after ascending but a few feet, their further advance against the enemy was precluded by an unclimbable precipice. The moment that the first shots were fired companies doubled straight at the points whence the firing seemed to have proceeded, and commenced to scale the hill. Soon, however, they came upon a perpendicular wall of rock, from the summit of which the Boers were plying their rifles at half-a-dozen yards' distance. Here fell Lieutenant-Colonel Eager, and close to him Major Seton of the Royal Irish Rifles. Colonel Eager was the man who reached the highest point attained by any of the attackers, and was then shot down, where many another British officer has fallen before now, at the head of his battalion, gallantly leading them as in the days of old, when long-range weapons had not been invented."

Others hinted that it was the habit of the General to overwork his troops—a habit so well known that it had earned for him in Egypt the title of "General Backacher." Further comments were made by those who always find the art of criticism so much easier than the art of performance, but to repeat them at a time when the principal actors in the sorry affair are unable to defend themselves would be unjust and ungenerous. Our Generals, besides treachery, had from the first unusual ignorance to deal with. One of our misfortunes has been the necessity to rely for information on friendly Kaffirs, or those who affected to be friendly. Now, as all know, the Kaffirs, even when honest, are scarcely reliable. Their notions of size, for instance, are on a par with those of the man who described the dimensions of a bump by saying it was about the size of a piece of chalk. To the Kaffir an impi is an army, whether small or large, and it is almost impossible to bring home to him the value of exactness. In fact, in the matter of ambiguity the Kaffir has the makings of a politician, and therefore it was no wonder that so many of the well-organised military schemes in this unlucky war came to grief. But in the case at Stormberg there were other difficulties to contend with. The map of the ground was utterly unreliable. The configuration of the hills was incorrectly presented and the distances badly judged. The general knowledge of the direction was so imperfect that none was sufficiently well informed to put a check upon the movements of the guide, nor had the position been reconnoitered by any of those engaged against it. In this way the winding and circuitous route more than doubled the march, knocked up the troops, and ruined the effect of the night assault; for it was full daybreak before the British approached the point of attack. One of the sufferers from the disaster declared that the British were so worn out that after the engagement they threw themselves down and did not mind whether they were taken prisoners or not. He himself crawled to within three miles of the base camp, and then lay down on the veldt and fell asleep. How long he remained asleep he did not know. Most of the prisoners, he believed, were taken by the Boers while the men were asleep.

[Pg 167]

A report was circulated that General Gatacre had shot with his own hands the guide who led him astray, but this statement was entirely incorrect. The military authorities thoroughly sifted the case of the sergeant of the Cape Police who acted as guide on the occasion, and it was allowed that he erred genuinely in mistaking the enemy's position.

The following officers were wounded in the engagement at Stormberg:—

2nd Royal Irish Rifles—Lieutenant-Colonel Eager (since dead), Major Seton, Captain Bell, Captain Kelly, Lieutenant Stephens, Lieutenant Barnardstone. Suffolk Regiment—Second Lieutenant Maynard. Missing: Captain Weir, Lieutenant Christie, Second Lieutenant Rodney. 74th Field Battery—Lieutenant Lewis. 77th Field Battery—Major Percival. 2nd Northumberland Fusiliers—Missing: Major

The scene of General Gatacre's disaster was on the junction of the eastern line of railway in Cape Colony running from East London through Queenstown, Molteno, and Burgersdorp to Bloemfontein in the Orange Free State. There were many strategical reasons for wishing to seize upon it. First, it was desirable to engage the enemy in the centre, and so save the Boer commandoes from falling in too great strength on Lord Methuen's line of communications. Secondly, from the situation of the place it was possible also to effect a junction by rail with General French. Thirdly, a victory gained in the centre of the disaffected districts would have been a feather in the cap of the General, for it must have drawn to him such waverers whose vacillating loyalty was daily growing dangerous. The melancholy reverse was, therefore, from many points of view to be regretted. Perhaps, however, it achieved one object. It forced those at home to realise the necessity for sending more than sprinklings of troops to meet a strong, courageous, and well-equipped foe.

The General, in giving an explanation of the reverse, declared that the operation which proved so wretched a failure was started under the promise of complete success. By himself and the local guide, however, the distance was under-estimated. He did not consider that the guide was guilty of treachery, merely of unintentional error. However this may have been, it is certain that the British plans were entirely well known, and that the Boers had had ample time to prepare for the coming of the force. It was evident that the gallant General did not take a leaf out of the book of Metellus, the Spanish commander, who, when asked how he should proceed the next day, said, "If my shirt knew I would put it in the fire." Possibly, being a great theorist, as was poor Sir George Colley, he may have agreed with the opinion held by Marshal Bugeaud, that military affairs were too often wrapped in mysterious silence. Certainly there was no secrecy about the strategy of the advance on Stormberg, and the guileless manner in which the General trusted to the guidance of a local policeman was commented on none too generously by the distressed public, whose disappointment was too great to allow them to look coolly at the ups and downs of warfare and the fallibility of human designs. General Gatacre, after the reverse, held Bushman's Hoek and Cyphergat, two positions to the south of Molteno, where he could await the reinforcements which would shortly reach him from the Cape.

AT MODDER RIVER

At dawn on the day following the battle the guns opened fire, with a view to effecting the clearance of the enemy, but it was soon discovered that the Boers had made themselves scarce, preferring to march through the long midnight hours to remaining where a chance of the bayonet might be awaiting them. Their artillery they at first left, but discovering that the British had not crossed the river, they returned and removed it to Spyfontein, where the next encounter was expected to take place. Had only the troops been less worn out—they were so expended that they could scarcely move one leg before the other—these guns might have been captured and victory assured. But fatigue must overcome the finest warriors, and ours had done prodigious work in circumstances of the most trying and varied kind. The next morning Lord Methuen's forces quietly occupied the town, and spent the day in the melancholy duty of burying the dead.

Owing to the carcasses of beasts and the corpses of dead men in the stream, the troops had soon to bivouac some three miles farther up. There they could enjoy the rare luxury of a bath and drink their fill in safety. No "wee drappie" ever cheered the heart of Scotsman as did the quarts of Modder that went down the throats of thirsty Highlanders who had been toasted inside and out during the long hours of the battle. As one appropriately, if not elegantly, described it:—

"When it comes to slaughter
You'll do your work on water,
And lick the bloomin' boots of him that's got it."

But the water everywhere was bad, and for safety boiling was imperative. For some days the men had been bathing in and drinking from the polluted stream, and it was quite wonderful that enteric had not seized upon the troops. A Dutch lady stated that she had seen four dead Boers with stones round their necks thrown into the river by their comrades, but when the bed of the stream came to be investigated, at least seventeen corpses were hauled out. The enemy's loss was estimated at 500, and doubtless those of the slain who were not lying under an inch layer of sand were disposed of in the river. The air, too, was far from salubrious. The winds of evening were reminiscent of the dead horses and mules that remained half-buried on the banks. Fortunately the vultures and ants, and other useful agents, soon reduced the pestiferous masses to harmless skeletons.

Meanwhile the rest of the Highland Brigade was on its way up to join Lord Methuen at headquarters. Some went by train and others marched, as the line—a single one—was frightfully congested with traffic. Stores and ammunition and baggage of all kinds were being sent up, while the wounded, in "emptied" trains, were being sent down. The march was a trying one, even for hardy men who could well have managed twenty-five to thirty miles a day on their native heath. Now, they were supposed to carry 35 lbs. each, without counting clothes, and twelve miles a day in the broiling heat of a South African midsummer was counted remarkably good going. What

with rifle, 100 rounds of ammunition, a big coat, a two-quart water-bottle, field-glasses, and haversack, officers and men were nearly as heavily weighted as itinerant peddlers. They carried their warlike pack over sandy roads that threw off clouds of dust which caked hair and skin, and made the whole outer man a complete study in kharki. What failed to go down their throats went into their eyes, blinding or worrying, while overhead a merciless sun blazed and tortured. There was no shade; there was little water. The night was cold as the day was hot. In the small hours the men were thankful for the single blanket which was allowed each of them, and which was carried in mule and bullock waggons for their use. Luxuries for the toilet were no longer in vogue. A sponge, a shirt, a pair of socks—these made the sum total of the Highland officers' wardrobe. Some still stuck to their razors, and others had succumbed to necessity and wore nature's hirsute decorations, plus a peppering of ochreous dust. But they were in the best of tempers, and looked forward to some reviving dips in the Modder on their arrival there.

Lord Methuen resumed command of the troops on the 6th of December, and all were glad to find that the injury to their gallant commander had been slight. It was now clear that the Boers intended to make a stand at Spynfontein, for they were preparing for themselves fortified positions such as their souls delighted in—deep, and long, and rocky. They had time at their disposal, for a long halt at Modder River was imperative for the purpose of replenishing the ammunition of the artillery batteries and for bringing up relays of stores and food. Our expenditure of ammunition in the fight on the 28th was said to have been 200 rounds per gun, and consequently an extra supply was necessary before pursuing aggressive operations.

Having deserted the river, the Boers were now planted in front of and on the British right flank, so close indeed that daily passages at arms took place between our patrols and those of the enemy. Several of Rimington's Scouts were wounded, and wild rumours of approaching attack were afloat. During the night of the 6th and the morning of the 7th the communications by rail and telegraph at Enslin were cut.

[Pg 171]

On this occasion the 2nd Northamptonshire Regiment had a narrow escape. They had been left by Lord Methuen to guard the line of communications at Enslin, and there they were attacked by a Boer force 1000 strong. Fortunately the General, hearing the news, despatched in hot haste to the assistance of the regiment the 12th Lancers and the Seaforth Highlanders, who had just arrived at the camp, under Brigadier-General Wauchope, together with the 62nd Field Battery. The attack commenced at 4.30, and continued till eleven, at which time the Lancers and Seaforths appeared. The Boers thereupon retired with all speed, the Lancers following closely in pursuit. The British loss was one killed and six wounded. On the same day the first train ran over the temporary bridge which had been rapidly constructed by the Engineers, whose smart workmanship elicited general admiration.

An interesting affair took place on the 9th of December. At night one of the Naval 4.7-inch guns, which had been fitted with a field-carriage and dignified with the name of "Joe Chamberlain," was hauled by a team of thirty-two oxen to a ridge on the north side of the town. At an early hour in the morning the Naval detachment manned the gun and opened fire on a Boer position that had been previously located by Colonel Rhodes. More than a dozen shells were scattered among the enemy, causing frightful consternation. The Boers at the time were busily engaged in constructing an emplacement for one of their 40-pounders, but when "Joe Chamberlain" made himself not only heard but felt, there was a stampede. The lyddite ploughed up the hills with terrific uproar, and the surrounding atmosphere appeared as though a sirocco of red sand had swept over the district.

The force now massing on the Orange River, with Lieutenant-General Lord Methuen in command, consisted of:—

2nd Yorkshire Light Infantry, 2nd Northamptonshire, 1st Loyal North Lancashire (Mounted Infantry), 1st Loyal North Lancashire, 1st Northumberland Fusiliers, 3rd Grenadier Guards, 1st Coldstream Guards, 2nd Coldstream Guards, 1st Scots Guards, 9th Lancers, 1st Argyll and Sutherland Highlanders, 1st Highland Light Infantry, 2nd Seaforth Highlanders, Part of 2nd Royal Highlanders (Black Watch), several Companies of Royal Engineers, 18th, 62nd, and 65th Field Batteries, one or two Horse-Artillery Batteries, part of Kimberley Light Horse, part of Diamond Fields Horse, Naval Brigade, Contingents from Australia, several Companies of Army Medical Corps, Field Hospitals, Colonial Mounted Irregulars, Rimington's Scouts, South African Reserve.

The total was about 14,000 men.

The number of Boers prepared to meet the British advance was supposed to be between 15,000 and 18,000, but, in spite of this, it was decided that some onward move must soon be made. The week's delay for the arrival of reinforcements and other preparations was now over, and Spynfontein was ahead. There the Boers held, if possible, a stronger position than any that had yet been attacked. Towards the east they were congregating from the direction of Jacobsdal, and the extent occupied by them was already enormous. Lord Methuen, if he meant to get to Kimberley at all, was forced to attempt to do so by frontal attack, as the area occupied by the Boers was so great that no other means of tackling them was feasible. Still the troops were in excellent spirits, the prospect of shortly relieving a besieged multitude giving them courage to compensate for their fatigue.

[Pg 172]

On the morning of the 10th there was a voluntary Church Parade. According to a wag who reported from the camp, a Saturday-night's order was given, which stated briefly that Presbyterians must go washed, Church of England might go unwashed! The question of ablutions did not affect the devotions of Tommy, who heartily joined in the singing of hymns, which he said

reminded him more than anything else of home.

THE BATTLE OF MAJESFONTEIN

On Sunday, the 10th of December, Lord Methuen, having completed his plans, moved forward from his position for the momentous fight, which was not only to decide the fate of Kimberley, but determine the attitude of the waverers among the Dutch, of which there were now very many. The Boers occupied a wide crescent-shaped front, extending some six miles from the hills on the west of the railway at Spysfontein to the kopjes on the east of the Kimberley road at Majesfontein.

The northern portion of the position consisted of a kopje about three miles long, and the southern end terminated in a high hill which was looked upon as the key to the position. Towards these rugged kopjes the veldt sloped gently upwards from the river a distance of five miles, and though from afar this plain seemed to face the ridge of hills spreading from east to west, it in reality penetrated wedgewise into the boulder-strewn area. Someone described the great Boer position as the end of a pocket, a veritable *cul de sac*, doubtless lined with Boer guns and Boer trenches—the jaws of a dragon, in fact.

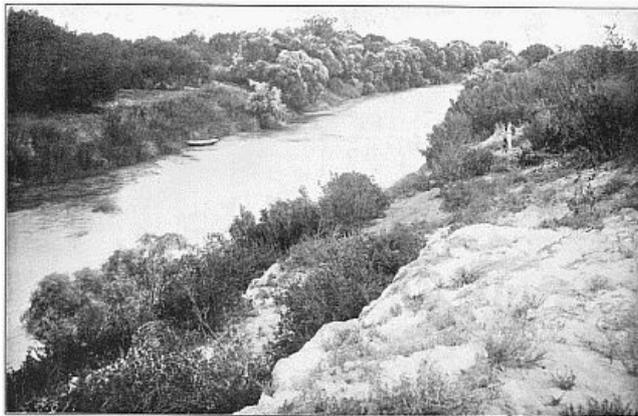

THE MODDER RIVER.

Photo by Miss E. C. Briggs.

Orders were given that this stronghold was to be bombarded, and from 4.50 P.M. to 6.30 P.M. the guns, including the Naval 4.7-inch, played over kopjes and trenches with accuracy, and, it was thought, with deadly effect. The operation was carried on with precision and perseverance as long as a gleam of daylight lasted, but no response was elicited from the enemy, who carefully concealed their very existence. At night a tremendous downpour of rain descended and saturated the troops, who were bivouacking where they were, some 4000 yards in front of the Majesfontein position, thus rendering their already uncomfortable situation more uncomfortable still. But this was merely an item in the misfortunes they were shortly destined to endure.

[Pg 173]

The general plan was for the Highland Brigade, supported by guns, to assault the southern end of the kopje, their right and rear being protected by the Guards Brigade. According to Lord Methuen's despatch, it seems that before moving off Major-General Wauchope explained all that was to be done, and the particular part each battalion was to play in the scheme: namely, that they were to march direct on the south-west spur of the kopje, and on arrival near the objective before daybreak the Black Watch were to move to the east of the kopje, where he believed the enemy to be posted under shelter, while the Seaforth Highlanders were to march straight to the south-east point of the kopje, with the Argyll and Sutherland Highlanders prolonging the line to the left; the Highland Light Infantry to be in reserve until the action was developed. The brigade was to march in mass of quarter columns, the four battalions keeping touch, and, if necessary, ropes were to be used for the left guides. The three battalions were to extend just before daybreak, two companies in firing line, two companies in support, and four companies in reserve, all at five paces interval between them.

Soon after midnight the march began. The distance was only two and a half miles, and daybreak was due about 3.25 A.M. But the gruesome night rendered the progress of the troops unusually slow. Rain came down in torrents, thunder growled, lightning played over the hill, glinted on rifles, and disorganised the compasses by which Major Benson was steering his course. Towards dawn the gloom of Erebus seemed to deepen rather than lift, and in the obscurity they must have been quite unaware of the exceedingly close proximity of the enemy, for the Highland Brigade—in the following order, Black Watch, Seaforths, Argyll and Sutherland, and Highland Light Infantry—continued to approach in quarter column though within some two hundred yards of the Boer entrenchments. It was imagined that the Dutchmen were in force on a kopje on the other side of the veldt, and not a soul suspected the existence of the formidable line of intrenchments on which our soldiers were gaily advancing. Before they could discover their mistake they were greeted by the Dutchmen—who had allowed the brigade to approach without showing any signs of life—with a raking fire on their flanks. The whole hill seemed on the instant to become alive with the roar of musketry. Fire vomited as from a live volcano at their very feet. A moment before they had seen only a dark barrier of bush and shrub, and then, flash! the earth yawning, cracked,

[Pg 174]

Highland Brigade, and the magnificent coolness and daring of its officers, quite equalled the most splendid deeds of British history. The Brigade about noon was reinforced by the Gordons, and these, as they advanced towards the wire-girded trenches, were exposed to a terrific cross-fire from the enemy, their route having taken them past a Boer trench from which the concealed foe promptly assailed them, and they found themselves literally battered by volleys in front, flank, and rear.

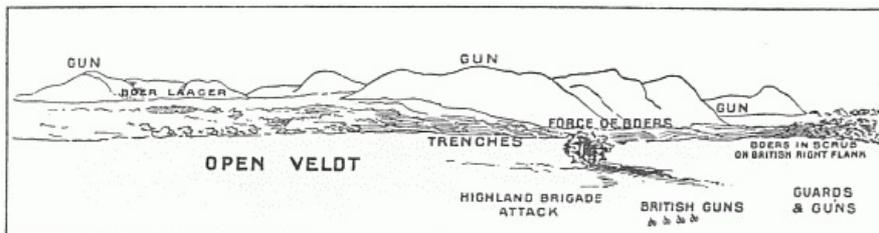

SKETCH MAP OF POSITIONS AT MAJESFONTEIN

The Guards Brigade meanwhile were taking a heavy share of the work. They occupied the centre and right, moving due north over a level plain which was shelled by the Boers from the ridges. The extreme right rested on the river, where the Yorkshire Light Infantry, under a tremendous fire, held the drift. These clung tenaciously to their position throughout the day, even after all their ammunition was exhausted. They fired in all some 7000 rounds, inflicting terrible damage and losing only ten wounded.

About two o'clock, after the enemy had been reinforced, the firing, which had temporarily slackened, began again with stertorous uproar. The air was thick with projectiles dealing death and mutilation on every side. Then it was that the real disaster of the day occurred. The portions of the shattered Highland Brigade, which, in spite of the shock to its numbers, had stuck manfully to its terrific duty, suddenly became disorganised. As a matter of fact, though it was not at the moment recognised, nearly all its officers had fallen. A few minutes later and they retired, by whose order none knows. The order was given. No shouting of counter-orders could rally them; and indeed how could it, since the revered familiar voices of their commanders were silent, some of them perhaps never to be heard again! Major Ewart, Brigade-Major of the Highlanders, rode up with an order—almost an entreaty, some say—from the commanding officer to the effect that all he asked of the Brigade was to hold the position till dark. But the officer in this desperate situation could actually find no other to help him to repeat the command to the scattered remnant, and he was thankful for the assistance of Colonel Dawney, who, as a civilian, was surveying the battle from Horse Artillery Hill. Eventually a rally was effected, and the brigade, stiffened and supported by the Scots Guards, got back to the guns; but their nerve was shattered by the terrific experiences of the morning, by the losses they had sustained, and by the disappointment of being unable to fulfil the glorious expectations which the renowned Highland Brigade has ever encouraged and ever nobly fulfilled.

[Pg 177]



MAJOR-GENERAL ANDREW G. WAUCHOPE, C.B.

Photo by Horsburgh, Edinburgh.

It will serve no purpose to dwell further on the miserable details of mighty effort wasted, splendid lives sacrificed, and gallant hearts crushed by mischance. There are moments when, like the Oriental, one can but lift helpless hands to the Unseen and cry "Kismet!"

While the engagement was going forward, Major-General Pole-Carew sent an armoured train, under cover of a Naval gun, within 2500 yards of the Boer position. This gun during the whole day, whenever occasion required, made itself prominent by its magnificent practice, firing lyddite shells behind the main ridge, and searching kopjes, trenches, and laager with amazing accuracy. For instance, at one moment a train of bullocks drawing guns was seen by the Naval Brigade—in the next the whole affair had ceased to exist! In the same summary way the Guards dealt with the foe. They came on a picket of some forty Boers, who had been left for purposes of observation, and in shorter time than it would take to tell the tale the whole party were killed, wounded, or taken prisoners. The troops held their own in front of the enemy, entirely clearing them out of the upper intrenchments until darkness put a stop to the operations. This was another of the day's misfortunes, for at the very hour of dusk the Boers were deciding to evacuate their position. Then our troops intrenched themselves in face of the Boer position. But finally, on the following day, they had to retire to Modder River on account of the scarcity of water.

[Pg 178]

Nearly all the loss was borne by the Highland Brigade, who lost fifty-three officers either killed, wounded, or missing, and a total of 650 of all ranks. Our line was three and a half miles long, while that of the Boers was almost double. The loss of the enemy in mounted infantry was enormous, and their Scandinavian commando of eighty strong, which, under Baron Faderswold, had been removed from Mafeking, was entirely destroyed, every man being killed or wounded except seven, who were taken prisoners.

There seems to be little doubt that Lord Methuen's ill-success was largely due to treachery, for in the course of the battle an officer detected a Cape Dutchman on the left rear in the act of exchanging signals with the Boers. In fact, much of the information supplied both to General Gatacre and General Methuen was found to be deliberately false, and it was known that the districts through which they had to pass were seething with disaffection. For this reason most probably this glorious and desperate fight proved a drawn battle, but there were, of course, other possible causes to be considered. Lord Methuen had advanced from De Aar with a brilliant army which had already acquitted itself nobly, though with great loss, in three battles, against an enemy entrenched in stony hills. With his thinned force of some 8000 men he now hurled himself against troops which not only had been greatly reinforced, but were situated behind complicated earthworks miles in length, built on the most approved system of modern tactics.

In regard to strategy, there was no doubt that the Boers had scored. They had been lying in wait fully aware of our plans, and had the approach of the troops signalled to them by means of a lantern fixed high on the hills. The Highlanders were fairly at their mercy. By the time the shouts and orders and counter-orders had rung out, those who had uttered them were dead or dying, and many who were left were rushing—rushing and dropping—to get out of the fiery furnace into which they had been led. It must be remembered that on that day there was no artillery preparation; the heights had not been searched, and the enemy was master of the field. The artillery operated later in the morning; but after the first momentary retirement the Brigade of its own accord formed up, consigned itself again to the hell of flame and death, and there stuck as targets for the enemy till midday.

In the official despatch occurs the line, "I attach no blame to this splendid brigade." Fortunately there is none among the great multitude to whom the story of the tragic affair is known who would dream of associating the word blame with the glorious band who so grievously have suffered. Where the blame rests it is not for the civilian to say. Indeed the exact facts of the matter can never be known, as the two dead heroes most concerned cannot speak, and those who live can never argue with certainty of facts occurring in the turmoil of battle. In reference to the Brigade Lord Methuen said:—

[Pg 179]

"I have made use of Lieutenant-Colonel Hughes Hallett's report (the acting Brigadier) for the description of the part the Highland Brigade took in this action. Major-General Wauchope told me, when I asked him the question, on the evening of the 10th, that he quite understood his orders, and made no further remark. He died at the head of the brigade, in which his name will always remain honoured and respected. His high military reputation and attainments disarm all criticism. Every soldier in my division deploras the loss of a fine soldier and a true comrade. The attack failed; the inclement weather was against success; the men in the Highland Brigade were ready enough to rally, but the paucity of officers and non-commissioned officers rendered this no easy matter. I attach no blame to this splendid brigade."

Examples of individual daring and individual self-abnegation during this glorious though ineffectual fight were too numerous to be quoted. The Medical Staff, for instance, exposed themselves with a persistence that was truly marvellous, succouring the injured and carrying them off to shelter, till in some instances they themselves were shot. Very tragic was the state of the gallant wounded, the bravest of the brave, who had dared to advance too near the trenches, for these in the wretched plight could not even enjoy the medical attention lavished on the others, as no sooner were the doctors seen to be approaching them than a storm of fire was immediately sent in their direction. The patience of the sufferers was at times more than heroic. Notwithstanding their agonies and the horrible pangs of thirst that are the inevitable result of wounds, some, knowing that water was too scarce to go round, would not consent to do more than moisten their lips from the water-bottle offered them, while others hid the fact of their being wounded, so as not to absorb attention from those more in need of it than themselves.

The Marquis of Winchester was one of those who fell nobly. For the most part of the day he seemed to have a charmed life, and though bullets whizzed through his helmet and round his ears, he moved fearlessly among his men instructing each as to the direction in which he should

fire. At last, however, came the fatal shot which pierced his spine and laid him low.

The gallant colonel of the Gordons, Colonel Downman, was seen shouting on his men till a bullet dealt him a mortal wound. Another Scottish hero, a private, was heard wildly remonstrating as the stretcher-bearers tried to remove him from the field. His ankle was smashed, but he still roared that he had been wounded for twelve hours, and had been fighting all the while, and was still as fit as any man in the army!

[Pg 180]

He was not alone in his valour, for instances of remarkable gallantry occurred on every side. Sergeant Gash (Rimington's Horse) singly assisted a wounded man, sticking to him under a heavy fire till the poor fellow was placed out of harm's way, and Lieutenant Riley (Yorkshire Light Infantry) bore on his back a man of the Mounted Infantry while covered by Sergeant Cassen and Privates Bennett and Mawhood. The reason why so many officers fell may be attributed to the fact that the Boers employed sharpshooters who walked coolly about lifting their field-glasses and picking off such persons as appeared in any way conspicuous. The prominence of the officers, however, was not due to peculiarity in their uniforms, they having discarded swords, revolvers, and belts, and adopted kharki aprons over their kilts. One of the Seaforth Highlanders wrote pathetically of the awful day's work. He said:—

"We were in quarter-column of companies in line—that is, we were offering a front of, say, 50 yards—and immediately behind, following in double ranks, were company after company of the Highland Brigade, of, say, 3500 men. Suddenly the whole hillside was one mass of flame, and the Seaforths, leading, received a discharge of rifle-fire from over 16,000 Boers. It was awful. Talk about 'hell'—the hillside was one continuous line of fire. We immediately scattered and spread one in lines right and left.... Monday's work was a huge blunder, and who is to blame I do not know; but there is no doubt the Highland Brigade were led like lambs to the slaughter. We were led more as if we were on a Volunteer review at Hyde Park. We had a sorrowful job on Tuesday night. We had fifty-three dead brought in and buried. You could hear nothing but the wailing of the pibrochs as the Highlanders were buried."

A colour-sergeant of the 2nd Black Watch writing from hospital thus described the moments when the unlucky Brigade which had stood gloriously against the terrific shock first became disorganised:—

"The brigade was moving in mass of quarter-column, with a few mounted scouts in front and our battalion leading the Brigade. We had to file through a narrow part and form up as we got through, and when my company got to its place I could see the dim outline of the hill in front, and thought we were in a very dangerous place if the enemy, as I thought, occupied it, for it was the extreme left of their position, and therefore they were bound to strongly hold the flank. However, the brigade formed up nicely on the open ground, and a lamp that was shining on the left on a prominent spur was put out. Simultaneously the whole of the hillside was lit up with the most damnable discharge of rifles, &c., that any one can possibly imagine. They seemed to be formed up in tiers all up the hillside, and were pouring magazine fire into us at a terrific rate. Then came all sorts of shouts—'Lie down,' 'Charge,' 'Extend,' &c., and of the whole brigade there was only the front rank of A Company of ours that could have used their rifles, as everybody else was straight in rear of them. Well, two companies in front did charge, but were stopped by barbed wire fences and entanglements fifteen yards from the trenches and mostly shot down. Others broke to right and left or retired, and after waiting about a minute for a bullet to hit me, as it appeared impossible to escape one, and as it did not arrive, I thought perhaps it was advisable to go with the remainder. I walked away to the right, still expecting one, but they were all going too high, and it was not yet light. I got clear away and discovered a mob of excited soldiers of all regiments, and with Captain Cameron we tried to get them together, but they had lost their head, and several Boers who had moved out of the trenches to get round our flank happening to fire in this direction, they became disorganised. It was then daylight before sunrise. The Boers, moving smartly, then showered us with bullets, and many were bowled over. I walked along quite casually, shouting to one and another to take cover and keep cool, and I was once followed about 200 yards by quite an accompaniment of bullets, I should say about twelve keeping it up; but as they were evidently aiming at me, none hit me. Slowly getting back with any amount dropping, I lost sight eventually of these persevering gentlemen, when another alarm came from a fresh direction. Thinking possibly it was some of our own troops, I lay down behind an ant-heap facing the direction, loaded my rifle, and waited to be certain before firing. I did not fire, however, as at that moment somebody hit me on the back of the neck with a bar of iron weighing two tons and a half, for so it seemed to me; it quite numbed me for a few seconds, and a chap who had lain down beside me shouted he was shot and began to howl, upon which I politely asked him to shut up and get it bandaged, and I then moved away to find out where they were forming up. After half an hour my equipment became too heavy for me, and meeting a stretcher-bearer he took it off and bandaged me up. The bullet had entered the left side of my neck, and, taking a downward course, passed through the neck and out at the back of the right shoulder. I was then conducted to the ambulance and away to hospital, and on my way down saw the Gordons marching up from the baggage to take a part in it, but the artillery had been working away for two or three hours then."

[Pg 181]

Could any troops, officerless, unhinged, riddled through and through, instantly gather themselves together with sufficient force to hold out against a foe flushed with triumph and intoxicated with success? Impossible! Students of Napier may recall the description of the panic to the Light Division in the middle of the night, when no enemy was near, and may understand how the bravest and most warlike troops, when exposed to unexpected and unknown danger, have shrunk back in dismay. On the occasion referred to some one called out "A mine!" and such was the force of the shock to the imagination that "the troops who had not been stopped by the strong barrier, the deep ditch, the high walls, and the deadly fire of the enemy, staggered back appalled by a chimera of their own raising." If this result can have been effected by a chimera, how then could anything else be expected by a real shock, a tangible shock, such as the gallant Brigade suffered in that dark hour of horror and despair? It is difficult for the outsider within the protecting walls

of home to realise the awful moments, each long as a lifetime, through which these noble fellows passed—moments full of heroism as they were full of pathos! For instance, when the clamour of battle was at its loudest, when no voice of officer could be heard, and the stricken Highlanders were groaning in heaps upon the blistering veldt, Corporal M'Kay, of the Argyll and Sutherland Highlanders, standing in the midst of the cyclone of lead, struck up "The Campbells are coming" in order to rally the unfortunate men. These, jaded and broken as they were, drew taut their aching limbs, and, reviving with the heartening strains, once more dragged themselves towards the whirlwind of lead, determining once more either to do or to die.

[Pg 182]

The desperate situation in which the Highlanders were placed may also be pictured from descriptions given by two more of their ill-starred number.

The first wrote:—

"At twelve o'clock we started to advance. Well, we got to within 500 yards of the position, and if ever a man was led into a death-trap my regiment was. We led the brigade. Our general must have been under the impression that the Boers had left the hill, for he had us up in mass of quarter column. When we got within 500 yards they opened fire at us. My God, I shall never forget it in my life. It was terrible, fearful; we were shot down like dogs, without a chance to return their fire. The groans of those hit sound in my ears yet, and will do for many years to come. Well, as soon as they opened fire we fell flat, and got the order to fix bayonets and charge. We did so. The Black Watch only got into their trenches, and I am happy to tell you my bayonet has still got on it the stain of a Boer's blood. Not having any support from any other regiment, we got the order to retire to 400 yards, and I can tell you there were not many who got into the trenches who ever left them. There is hardly any man in the regiment that has any part of his equipment left whole. I have three holes in my kilt."

The second corroborated the above statement:—

"The Black Watch in front made an attempt to charge the position, but we had to retire and simply run for it, the enemy blazing at us all the way and dropping our fellows like skittles from their splendid positions. There was nothing for it but to lie down and pretend to be dead, and this I did about 5.30 A.M. till I suppose 6 P.M., the sun pouring down on me all the time, and not a drink of water all day, and dare not stir hand or foot, and expecting every instant to be my last. I could hear nothing but the cries, moans, and prayers of the wounded all round me, but I daren't so much as look up to see who they were. Shots and shells were going over me all day from the enemy and our side, and plenty of them striking within a yard of me—I mean bullets, not shells—and yet they never hit me. I believe some of the fellows went off their heads and walked right up to the enemy's place, singing till they dropped them. One youngster lying close to me said he would make a dart for it about 3 P.M. I tried my best to persuade him not to, but he would go. A couple of seconds after I could hear them pitting at him, and then his groans for about a minute, and then he was quiet. About this time the sun began to get fearfully hot, and I began to feel it in the legs, which are now very painful and swollen, besides was parched with thirst. Most of the wounded round me had ceased groaning by this time. As it began to get dark, I managed to wriggle my body through the shrub farther back, and after I had been at it some time, on looking up found myself right in front of another intrenchment of the enemy. They sent a few rounds at me, but they struck just in front and ricocheted over my head. After a bit, it getting darker, I got up and walked back, and there was nothing but dead Highlanders all over the place."

[Pg 183]

Can anything be more pathetic than these rough outlines of the tragic scene where so many valiant souls sacrificed their lives without a chance to win for themselves even the shroud of glory? Truly in this surprisingly-fought yet disastrous battle—

"A thousand glorious actions that might claim
Triumphant laurels and immortal fame,
Confused in crowds of gallant actions lie,
And troops of heroes undistinguished lie."

Dim, as the dawn of that dire December morning, is our knowledge of the real agony of those appalling moments, the absolute magnificence of these human souls who were ordered to march to the grave as surely as was the Light Brigade at Balaclava. For though Balaclava was a scene of triumph and Majesfontein was one of misery, both brigades started gloriously forth, and both were martyrs to a mistake. If ever monument should be erected to the brave Scottish dead who were sacrificed at Majesfontein, these four words should be carved thereon, that all who hereafter may read of their high failure may remember also, that this failure was entirely due to the tragic fact that "Some one had blundered."

The picture of disaster given by the *Daily News* was heart-breaking:—

"General Wauchope was down, riddled with bullets; yet gasping, dying, bleeding from every vein, the Highland chieftain raised himself on his hands and knees and cheered his men forward. Men and officers fell in heaps together. The Black Watch charged, and the Gordons and the Seaforths, with a yell that stirred the British camp below, rushed onward—onward to death or disaster. The accursed wires caught them round the legs until they floundered, like trapped wolves, and all the time the rifles of the foe sang the song of death in their ears. Then they fell back, broken and beaten, leaving nearly 1300 dead and wounded."

Yes; dead and wounded—for many of the latter even remained there till morning. Among these was poor young Wauchope, the soul of gallantry. He was hit in four places, and lay for hours in the bitterly cold night glued to the ground in his own gore. He was not picked up till dawn. But gruesome as was his position, he was in the company of heroes. Round and about were the most splendid fellows that had ever worn kilt; Colonel Coode, and brave brilliant MacFarlan, the Adjutant of the Black Watch, who, times and again, rallied not only his men, but any stragglers

who could be got to follow his dauntless lead. And beyond all these, close in the teeth of the enemy, was the glorious General, the intrepid warrior, who, after distinguishing himself in many battlefields, in the shambles of Majesfontein "foremost fighting fell."

[Pg 184]

No word, no lament, can sufficiently express the mourning of the nation. Of him only can we say, as was said of Sir John Moore at Coruna, "If glory be a distinction, for such a man death is not a leveller!" Neither for such a man is there any death! Though his dust may mingle with the dust of the veldt, his actions must stand out for all time, and remind his countrymen that of such glorious, immemorial dust the British Empire has been built!

General Wauchope was born in 1846, and entered the army in 1865; was Lieutenant in 1867, Captain in 1878, Major in 1884, Brevet-Lieutenant-Colonel the same year, Colonel in 1888, and Major-General in 1898. He served in the Ashanti War in 1873, was slightly wounded in the advance-guard engagement of Jarbinbah, and severely wounded at the battle of Ordashu. He was mentioned in despatches, and was awarded the medal and clasp.

In the Egyptian War of 1882 he served with the Black Watch, and took part in the battle of Tel-el-Kebir, receiving medal with clasp and the Khedive's Star. Two years later he was in the Soudan Expedition under Sir Gerald Graham as D.A.A.G., and was severely wounded at El Teb, receiving the brevet rank of Lieutenant-Colonel and two clasps for his bravery. In the Nile Expedition of 1884-85 Colonel Wauchope was attached to Major-General Earle's river column, and in the engagement of Kerbeka was again wounded—this time very severely. At the conclusion of the campaign he was awarded two clasps. In 1898 he took part in the Soudan Expedition under Lord Kitchener, and led the first British brigade into action at the battle of Omdurman. For his services he was made Major-General, was awarded the medal and the Khedive's medal with clasps, and received the thanks of Parliament. When the present war in South Africa began, he was appointed to command the Highland Brigade of Lord Methuen's column.

In the political sphere Major-General Wauchope distinguished himself also, though he never entered Parliament. He was, however, Mr. Gladstone's opponent in the re-election for Midlothian in 1892. It was a fight which excited the keenest interest all over Great Britain, and was conducted by Colonel Wauchope with untiring energy. The result was that he reduced the Radical majority from the 4631 of the previous election (of 1885) to 690. He would probably have been returned in 1895, but he was then once more on the active list of the army. In June 1898 he contested South Edinburgh, but lost by a Liberal majority of 831. The news of his death caused a feeling of great distress in the Scottish capital, and the sorrow among his tenantry in Midlothian was intense.

[Pg 185]

The following is the list of officers killed and wounded:—

Highland Brigade (Staff)—Killed: Major-General Wauchope. Seriously wounded: Lieutenant Macleod (West Riding Regiment). Wounded: Lieutenant Wauchope (2nd Royal Highlanders), Lieutenant Vaughan (1st York and Lancaster Regiment), slightly. 2nd Royal Highlanders—Killed: Lieut.-Colonel Coode,^[9] Captain Elton, Lieutenant Edmonds, Captain Hon. Cumming Bruce, Captain MacFarlan, Lieutenant Ramsay. Wounded: Major Cuthbertson, Captain Cameron, Lieutenant St. J. Harvey, Lieutenant Berthon, Lieutenant Tait, Second Lieutenant Bullock, Second Lieutenant Drummond, Second Lieutenant Innes. Slightly wounded: Major Duff, Major Berkeley, Lieutenant J. Harvey. 2nd Seaforth Highlanders—Killed: Captain J. R. Clark, Lieutenant Cox, Second Lieutenant Cowie, Captain Brodie. Missing: Major K. R. Mackenzie. Wounded: Captain Featherstonhaugh, Lieutenant Chamley, Second Lieutenant Waterhouse (dangerously), Second Lieutenant Hall, Second Lieutenant Wilson, Second Lieutenant Clive, Second Lieutenant Baillie. 1st Highland Light Infantry—Killed: Captain Cowan, Captain Lambton. Wounded: Lieut.-Colonel Kelham (slightly), Captain Noyes (severely), Captain Wolfe Murray (slightly), Captain Richardson, Second Lieutenant A. J. Martin, Second Lieutenant Knight, Second Lieutenant Fraser, 1st Argyll and Sutherland Highlanders—Killed: Lieut.-Colonel Goff,^[10] Wounded: Major Robinson (since died), Lieutenant Graham, Second Lieutenant King, Second Lieutenant Scott (seriously), Captain Campbell (slightly). 1st Gordon Highlanders—of wounds: Captain Wingate. Dangerously wounded: Lieut.-Colonel Downman,^[11] Captain W. E. Gordon, Second Lieutenant Campbell. Seriously wounded: Captain Macnab. Guards Brigade.—1st Coldstream Guards—Wounded: Lieut.-Colonel Codrington, Major Hon. W. Lambton, Captain J. Sterling, Second Lieutenant W. Beckwith, Second Lieutenant G. Follett. 2nd Coldstream Guards—Killed: Major the Marquis of Winchester.^[12] Cavalry Brigade (Staff)—Wounded: Captain Briggs (1st Dragoon Guards), Brigade-Major. Mounted Infantry—Killed: Major Milton, Major Ray (1st Northumberland Fusiliers). Wounded: Lieut.-Colonel Bigron (Australian Artillery) (attached), and Lieutenant Cowie. Royal Horse Artillery—Wounded: Lieutenant Tudor (G Battery) and Major Maberley. Royal Army Medical Corps—Wounded: Lieutenant Douglas. Taken prisoner: Major C. H. Burtchaell.

[Pg 186]

FOOTNOTES:

[9] Lieutenant-Colonel John Henry Collier Coode, of the 2nd Battalion Royal Highlanders (Black Watch), entered the army in 1875, obtained his company in 1882, was major in 1890, and lieutenant-colonel in June 1898. From 1884 to 1889 he was an adjutant of the Auxiliary Forces, but until the present campaign had seen no active service.

[10] Lieutenant-Colonel Gerald Lionel Joseph Goff, of the 1st Argyll and Sutherland Highlanders, was the eldest surviving son of the late Mr. Joseph Goff, of Burton Grange, Herts, by his marriage with Lady Adelaide Henrietta Louise Hortense, a daughter of the second Earl of Ranfurly. He was born on March 8, 1855, and entered the army on March 10, 1875, from the Militia, being posted as a lieutenant to the 91st Foot (now the Argyll and Sutherland Highlanders). He obtained his company on July 1, 1884, and was

adjutant of the 1st Volunteer Battalion of the North Staffordshire Regiment from January 2, 1888, to January 1, 1893. He reached the rank of major on September 21, 1892, and that of lieutenant-colonel on July 23, 1898. This was not his first service in South Africa, he having taken part with the 91st Highlanders in the Zulu war of 1879, when he was present at the action of Gingindhlovu and the relief of Ekowe, for which he had the medal with clasp. He was a magistrate for Hants and Wilts, and resided at Hale Park, Salisbury. He married in 1894 Ellen, the youngest daughter of Sir Robert Dundas, of Arniston, Midlothian, who survives him.

[11] Lieutenant-Colonel George Thomas Frederick Downman, of the 1st Battalion Gordon Highlanders, who subsequently died of wounds received in this battle, joined the army twenty-three years ago, became captain in 1883, and major in 1891. In 1896 he was appointed second in command of his regiment, and received a brevet lieutenant-colonelcy in May 1898. He first saw service in the Soudan campaign of 1884, and was present at El Teb and Tamai, receiving the medal with clasp and the Khedive's star. In the Nile Expedition which followed he was with the River Column under Major-General Earle, and was awarded a clasp. In 1895 he was with his regiment in Chitral under Sir Robert Low, and took part in the storming of the Malakand Pass, being mentioned in despatches and receiving the medal with clasp. Then in 1897-98 he went with his battalion to the North-West Frontier under Sir William Lockhart and was present in the engagement at Dargai and at the subsequent storming of the Dargai heights, being mentioned again in despatches. He was present also at the capture of the Sampagha and Arhanga Passes, and went through the succeeding operations in the Maidan, Waran, and Bara Valleys. His name was mentioned also in these despatches, and his services secured for him, besides his brevet of lieutenant-colonel, two clasps. He was forty-four years of age, and was gazetted to the lieutenant-colonelcy of his regiment in July 1899.

[12] Augustus John Henry Beaumont Paulet, Marquis of Winchester, Premier Marquis of England and the fifteenth bearer of the title, was born in 1858, and succeeded his father in 1887. Educated at Eton, he entered the Coldstream Guards in 1879, was lieutenant in 1881, captain in 1890, and received his majority in April 1897. He served in the expedition to the Soudan in 1885 as aide-de-camp to Sir John M'Neill, and was present in the engagements at Hasheen and the Tofreck Zereba, and at the destruction of Tamai, receiving the medal with two clasps and Khedive's star. He went out to the Cape with his regiment in the *Gascon*, arriving there just a month ago. It was only on the previous Saturday that his appointment as second in command of the regiment was notified, the vacancy having been caused by the death of Lieutenant-Colonel Stopford at the battle of Belmont. Lord Winchester was the hereditary bearer of the Cap of Maintenance—a cap of dignity carried before the Sovereigns of England at their coronation. He was a D.L. for the county of Southampton, was unmarried, and is succeeded by his brother, Lord Henry William Montagu Paulet, formerly a lieutenant of the 3rd Battalion Hampshire Regiment, who has just attained his 37th year.

[Pg 187]

CHAPTER VI

CHIEVELEY CAMP

Deeply to be deplored, yet generally recognised, was the fact that so far, no decisive defeat had been inflicted on the Boers. We had fought gloriously, sometimes successfully; great men and brave had written their names in blood on the roll of heroes and had passed away, but nothing decisive had been done. It was true that the enemy had been routed time after time, but he had got away without chastisement, and in most cases with his guns. The main reason for his safe flight was our lack of cavalry, and also the fact, that such horses as we had were not of the same nimble build as those—inferior, yet smart—which were possessed by the Boers. These, thoroughly acclimatised and also educated to the curious nature of the boulder-strewn country, were able to career into space before our heavier chargers could get even with them.

Lord Methuen had fought three glorious battles successfully, and a fourth, equally glorious though productive of no result, inasmuch as the distance of his troops from Kimberley remained the same, while their numbers were very materially attenuated. It was reasonably to be supposed that a general who had come victoriously through three engagements—all accomplished within a week—should, in a measure, have exhausted some of his fighting material, and that such unequalled feats of arms as had been displayed must be paid for. The morale and stamina of the troops had been tried in every way. They had faced shot and shell at Belmont, at Enslin, and at Modder River. They had marched many miles under a torrid sun and slept many nights exposed to contrasting cold. Yet, at Majesfontein they had risen to the occasion, and flung themselves into the hurlyburly of battle as though a hint of fatigue were unknown. And their ill-success, it was discovered, was mainly due to treachery, against which it was almost impossible to be entirely guarded.

The one compliment that can be paid to a Boer is to call him "slim" or sly, and this slimness in warfare has helped the foe to circumvent the broader and more open tactics of the Briton. There was, indeed, no knowing how far or how ingeniously the ramifications of "slimness" had extended, and, to be even with them at all, our warriors have needed to add to the courage of lions the astuteness of weasels! Some of the Cape Dutch had worked surreptitiously for the foe, others affected an attitude of neutrality, more dangerous than open antagonism; while Kaffirs,

[Pg 188]

either from fear of being made biltong of, or for bribes, had lent themselves to delude and trick the British on more than one occasion. However, notwithstanding impediments, every one waited anxiously to hear a decisive note in the war news, and continued to hope for the best. Lord Methuen having done his part, all eyes were now turned towards the Natal force and Sir Redvers Buller, in expectation of relief. In England the tension was becoming painful; in the Cape it was causing colourless loyalty to become tinged with doubt; in the besieged towns it was bringing patience to the snapping-point. In effect, the whole nation was standing with bated breath for the great, the important stroke, and the entire world looked to Colenso, that hitherto unknown spot in the Empire, for one of the biggest battles of the campaign.

THE BATTLE OF COLENZO

On Friday the 15th December the Ladysmith relief column under Sir Redvers Buller attacked the enemy in full force. The Dutchmen held very strong positions north of Colenso, their camps and laagers being linked with those surrounding the southern side of Ladysmith, while to the south of the river they also held a formidable and commanding post. About three miles in front was an open plain, with hardly a vestige of cover in any direction. All around was a crescent-shaped constellation of high kopjes. The great hill of Hlangwane, on the left flank of the enemy, though it was not known at the onset, was strongly fortified, and *vis-à-vis* to the Hlangwane guns on the extreme right were posted more guns. Between these two eminences was the plain aforesaid, veined with dongas which reached to the terribly steep banks of the river, where were more intrenchments. From Fort Wylie, another of the fortified kopjes, the Boers commanded the little village of Colenso and the expanse of country through which Sir Redvers Buller proposed to advance to Ladysmith. The Tugela, wide and deep, ran between the foes, except on the left of the Doer position, where the Dutchmen held both banks of the river.

Upon their defensive works the Boers had spent a vast amount of labour. Besides rows of trenches cunningly concealed by grass and scrub upon the flats on both sides of the river, barbed wire entanglements complicated the situation both at the trenches and under the water at the river fords. The water of the river was also deepened by means of cleverly-made dams, in order that any troops which might endeavour to ford the current would find themselves carried off their feet.

[Pg 189]



THE BATTLE OF COLENZO—QUEEN'S (ROYAL WEST SURREY) REGIMENT LEADING THE CENTRAL ATTACK.

Drawing by J. Finnemore, R.I.

But, of course, the intricacy of these ingenious arrangements was only discovered at the cost of bitter experience. Later on, a great deal of after-the-event wisdom was forthcoming, and the ignorance of all concerned regarding the nature of the position to be attacked was severely commented upon. It was said that no satisfactory reconnaissance of the enemy's position was made, and that accurate knowledge of the nature of the ground to be passed over was not forthcoming. It was also averred that neither subordinate officers nor men were informed of what was expected of them, and that the only maps supplied to regimental officers were small-scale maps of the whole of South Africa, forty miles to the inch. However, it is clear that General Buller fully believed in his ability to force the passage of the Tugela, and viewed the position, though formidable, as less formidable than it really was. From all accounts it was plain that all the generals believed the village of Colenso to be evacuated, and none of them seemed to foresee very powerful opposition from that quarter or to take into account the exceeding rapidity with which the Boers managed to return to positions temporarily vacated.

Selections from the general orders of the day will show the proposed plan of action, and help to an understanding of how much one side may propose and the other dispose in a modern campaign:—

GENERAL ORDERS.

"Orders of Lieutenant-General Sir Francis Clery, commanding the South Natal field forces.

"1. The enemy is intrenched in the kopjes north of the Tugela; one large camp is reported to be near the Ladysmith road, about five miles north-west of Colenso. Another large camp is reported in the hills which lie off the Tugela in a northerly direction from Hlangwane Hill, a rough scrub-covered kopje.

"2. It is the intention of the General Officer Commanding to force a passage of the Tugela to-morrow.

"3. The 5th Brigade (Major-General Hart's) will move from its present camp at 4.30 A.M. and march towards Bridle Drift (a ford about four miles west of Colenso), immediately west of the junction of Doornkop Spruit and the Tugela. The brigade will cross at this point, and after crossing move along on the left bank of the river towards the kopjes north of the iron bridge.

"4. The 2nd Brigade (Major-General Hildyard's) will move from its present camping-ground at 4 A.M., and, passing south of the present camping-ground of No. 1 and No. 2 of the divisional troops, will march in the direction of the iron bridge at Colenso, and the brigade will cross at this point and gain possession of the kopjes north of the iron bridge.

"5. The 4th Brigade (Major-General the Hon. N. G. Lyttelton's) will advance at 4.30 A.M. to the point between Bridle Drift and the railway south, and can support either the 5th or the 2nd Brigade.

[Pg 190]

"6. The 6th Brigade (Major-General Barton's), less half a battalion as escort to the baggage, will move at 4 A.M. east of the railway in the direction of Hlangwane Hill to a position where it can protect the right flank of the 2nd Brigade, and, if necessary, support it or the mounted troops referred to later as moving towards Hlangwane Hill.

"7. The officer commanding the mounted brigade (the Earl of Dundonald) will move, at 4 A.M. with a force of 1000 men and one battery, No. 1 brigade division, in the direction of Hlangwane Hill. He will cover the right flank of the general movement, and will endeavour to take up a position on Hlangwane Hill, where he will enfilade the kopjes north of the iron bridge. The officer commanding the mounted troops will also detail two forces of 300 and 500 men, to cover the right and left flanks respectively and protect the baggage.

"8. The Second Brigade Division of the Royal Field Artillery will move, at 4.30 A.M., following the Fourth Brigade, and will take up a position whence it can enfilade the kopjes north of the iron bridge. The Sixth Brigade (Major-General Barton's) will act on any orders it receives from Major-General Hart. The six Naval guns, twelve-pounders, now in position north of the Fourth Brigade, will advance on the right of the Second Brigade Division Royal Field Artillery. No. 1 Division Royal Field Artillery, less one battery detached to the mounted brigade, will move at 3.30 A.M. east of the railway, and proceed, under cover of the Sixth Brigade, to a point from which it can prepare a crossing for the Second Brigade. The six Naval guns will accompany and act with the Brigade Division."

It must be remembered that the railway bridge had been blown up, but a footbridge still existed.

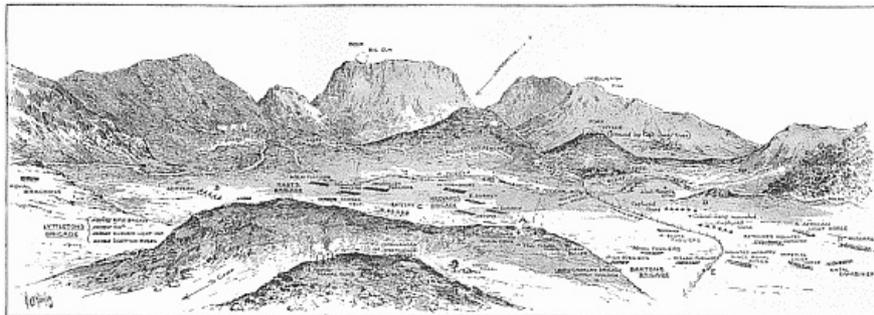

SKETCH PLAN OF BATTLE OF COLENZO, MADE ON THE SPOT BY A MILITARY DRAUGHTSMAN.

Before dawn Lord Dundonald with a mounted brigade and a battery of artillery moved to the east, while General Hart and his brigade started to try and cross Brindle Drift. The field-guns came next with cavalry—the 1st Royals and 13th Hussars—to protect either flank. Major-General Hildyard's brigade advanced to occupy the post of honour in the centre of the theatre of war. On the right were the West Surrey with the West Yorks in support. On the left marched the Devons with the East Surrey in rear. At 6 A.M. the Naval Contingent opened the proceedings. Their 12-pounders began to snort and to roar, and lyddite whizzed and shrieked over to Grobler's Hill and in the neighbourhood of Fort Wylie. But it whizzed and shrieked in vain. The Boers were "mum." They were "lying low," and had determined to keep their position masked as long as possible. They adopted the same tactics which had so confounded us at Majesfontein. The infantry now advanced, while Colonels Long and Hunt made haste—undue haste, as lamentable experience proved—to come into line with their field-batteries. At this moment, when all seemed to be going well, when Hart's, Hildyard's, and Barton's brigades were moving to their several positions, the sudden combined roar of Boer artillery and musketry was heard, coming not, as might have been supposed, from the distance, but *from the immediate front*, and apparently from all sides. A very cyclone of Mauser bullets swept all around, rattling and barking from the river bank, from trenches north and south of the Tugela, from Fort Wylie, and from every available point of vantage. Flame in tongues and forks belched out as from a crackling bush. The advancing infantry—the Devons and the West Surrey—found themselves almost carried off their feet; leaden hail beat the dust around, digging deep into the earth and sending up spurts of blinding dust, or whistling a warning of death to the heart of many an honest lad and true. So deadly, so awful was this fusillade, that it seemed impossible to do aught but flee. Yet the gunners stood tight to their guns, and the infantry with set faces like masks of bronze, regardless of the companions that dropped thick and fast around and upon them, stared Death straight in the face—stared at and

[Pg 191]

recognised and knew him, and still maintained their ground! More—they advanced; nearer and ever nearer to the invisible enemy they came, afterwards lying down and returning the fire with interest, while the guns of Long's and Hunt's field-batteries boomed and bellowed and vomited fire like Inferno released. Fort Wylie and its neighbourhood were swept with shrapnel and almost silenced, but only for a moment. Disaster was in the air. The concealed sharpshooters of the enemy, who crowded the Boer lines, had applied themselves to making a concentrated attack on the guns, picking off horses and officers and men, and finally reducing the snorting weapons which had been galloped too quickly into action, and were within 700 yards of the enemy's trenches, to a condition of pitiable impotence. Only the third field-battery and the Naval battery could move, and these were quickly drawn off to a place of safety. Amidst this scene of tragedy and uproar the Devons and West Surrey were steadily pursuing their way with a heroism that absolutely defies description. The enemy was driven out of the platelayers' and surrounding houses, and Colenso village was cleared. What the guns failed to do the bayonet accomplished, and before the glint of the steel—the cold, stern steel they so much dread—the Boers had bolted. But all around them Krupps and Maxims and Hotchkiss guns were still working hard, spouting and shrieking, and tearing earth and men and horses, and throwing them together in one horrible, hideous heap.

[Pg 192]

Certainly the advance of Hildyard's men was a noble achievement. Their effort to capture the road bridge and hold the village of Colenso in face of a scene of carnage was an act of splendid courage and determination; but they were assailed with so deadly a storm of shot and shell that they had no choice but to retire. Though they had imagined the village to be evacuated, the place had been swarming with Boers, they evidently having expected to be attacked in this quarter. Not only were they strongly intrenched, but the guns on the surrounding hills commanded the position, and when the Boers were temporarily routed the guns still continued to sweep the whole place with such unerring accuracy and fierceness that the ground was thickly strewn with the bodies of the mangled. Until those guns could be silenced, efforts of the infantry were so much waste of valiant flesh and blood; but our power to silence them was at an end. The guns of the 14th and 66th Batteries were doomed. They had, as before said, been approached too close to the river, and thus been exposed to the unerring rifle-fire of the Boer mercenaries. The attack was immediately returned, but before long the whole party, officers, gunners, and horses, were simply mown down. As fast as more horses were brought up they were annihilated. In addition to this the gunners ran short of ammunition. To await the arrival of this, such survivors as there were doubled back to the shelter of a donga twenty yards in their rear. At that time there was no intention of abandoning the guns. Superb were the efforts made to save them. Three officers rushed forward into the open, and, with some heroic drivers and such horses as they could get, made their way very deliberately towards the two field-batteries and into the mouth of a flaming hell. These were Captain Schofield, R.A. (A.D.C. to General Buller), Captain the Hon. F. Roberts, 60th Rifles, and Captain Congreve, Rifle Brigade. This glorious bravery was almost an act of suicide, and in sheer amazement at the wondrous valour of these dauntless Britons, the Boer rifle-fire, for one instant, was suspended. In the next, shot and shell burst forth afresh and the scene became too harrowing for description. Roberts, the gallant and the beloved, dropped, wounded in five places, while his horse was blown to bits, and Congreve, his jacket riddled to ribbons, was hit several times. Schofield, by a miracle, came whole from the ordeal, and succeeded in the almost impossible task of hauling off the two guns, for which all three and many others had risked their lives. The rest of the guns were captured by the enemy, but of this anon.

[Pg 193]



**THE BATTLE OF COLENZO—THE DUBLIN
FUSILIERS ATTEMPT TO FORD THE
TUGELA.**

Drawing by Rene Bull and Enoch Ward, R.B.A.

Major-General Hart's Brigade, consisting of the Dublins, Inniskillings, Borderers, and Connaughts, fulfilled in a measure what was expected of them. Some of them actually crossed the Tugela, but, alas! to no purpose. The position near the other side was untenable. A dam had been thrown across the water to deepen it. Cascades of artillery shrapnel were so liberally poured upon them, there was no holding up a head in such a fusillade. Yet they pushed on to the river, and the enemy fell back before them or dropped under their steady determined fire. The Dutchmen were driven to the north bank of the Tugela, and the Irish Brigade gallantly plunged in, thinking the water was knee-deep or at least fordable, and it was only then that they discovered that the wire entanglements that had been spread around the trenches were also

under water, and that the flood itself was unexpectedly deep, owing to the ingenious dam that had been constructed by the "slim" adversary. There were now ten feet of water instead of two, and sad was the plight of many a poor fellow of the Dublins and Connaughts, who, weighted with ammunition and accoutrements, found it impossible to swim to shore or even to return. They were drowned in the flood, while others dropped in heaps under the enemy's fire, and even under volleys of our own men, who, unluckily, mistook them for the foe. But the Irishmen's blood was up, and some, at any cost, determined to reach the other side to get one grip of the enemy, but what many of them thought to be the other bank was merely the bank of a winding spruit, which took them no farther towards the foe. The disappointment and rage was intense. Boom, boom, went the cannons roaring their dirge of death; bang, bang, bellowed the Naval battery in reply; rattling and raking came the bullets above the heads of the plunging Irishmen; splash, splash, sang the cold muddy water in their ears as they scrambled from rock to stone or swam for dear life. All that gallantry could do was done, but there was no appreciable advance with them, or indeed anywhere—ill-luck or bad management frustrated the best efforts on every hand. Men fell in heaps; horses with half their bodies blown away littered the veldt; the guns were stuck fast—useless lumber, too valuable to leave, too heavy to get away. Some say that had it not been for the action of the artillery commander in taking a whole brigade division—three batteries—up at a gallop to within 700 yards of the enemy's trenches, the day might still have been ours. The valiant Irishmen would still have pursued their risky advance. Others declared that the want of proper scouting caused the whole fiasco, and that all the pluck of the Irish Brigade was so much heroism wasted. They had no information relative to the intrenchments of the place to be attacked by them, nor any conception of the strength of the opposition they were liable to meet. No scouts appear to have discovered the position of the ford by which they were ordered to cross, or the nearness of the enemy to that point, and consequently the brigade marched in quarter-column into the very jaws of death, only deploying when shells had already begun to burst in their midst. Like the guns of the Royal Artillery, they found themselves before they were prepared in the midst of a close and deadly fusillade—the more deadly and unnerving because on the clearest of days not a whiff of smoke betrayed the quarters from whence the murderous assaults were coming.

[Pg 194]

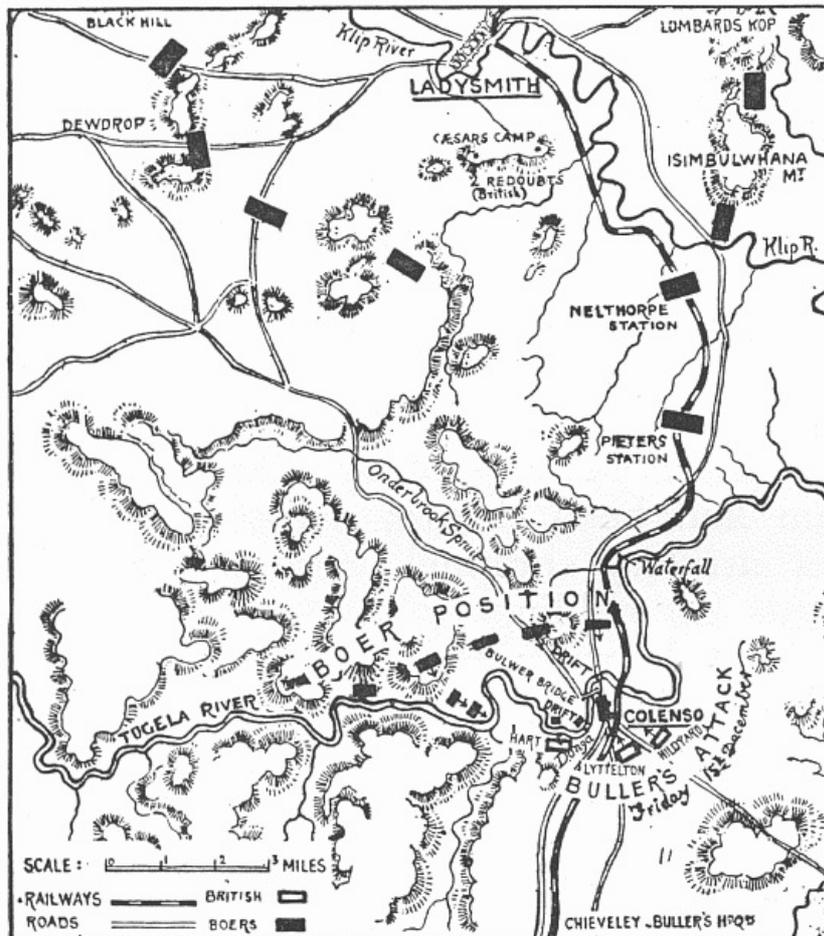

MAP SHOWING THE ATTEMPTED PASSAGE OF THE RIVER BY GENERAL BULLER ON DECEMBER 15.

General Barton's brigade, like Hart's and Hildyard's, failed to effect its object. It was found impossible to obtain possession of Hlangwane Hill, which was much more strongly held than it was believed to be. The troops were assailed from thence by such galling shell and rifle fire that they were eventually forced to retire.

[Pg 195]

On the extreme right, the mounted troops, under Lord Dundonald, made a vigorous attack at the Hlangwane Hill, on which was posted the Boer pieces which had wrought such devastation among the British batteries. However, in advancing up the valley, they were outflanked by the Boers, and had eventually to retire under a storm of bullets. The irregulars, for their part, worked splendidly. The South African Horse advanced on the front under a heavy shell fire. Thorneycroft's Horse, the Natal Carabineers, the Imperial Light Horse, and the Mounted Infantry at the same time attempted the flanking attack; but the Boer

lines, which ran along some high ground to the right of the flanking party, defeated their best efforts. Owing to the bad light, and to the fact that the Boers used smokeless powder, their fire failed to reveal their position, and the discomfort of the attacking party was considerable.

Meanwhile the 7th Battery, which was with Lord Dundonald, kept shelling Hlangwane and Fort Wylie in turns, the latter being done in order to assist the general advance. About noon Lord Dundonald was ordered to retire. This, however, was immediately impossible. So soon as the men began to move they became targets for the foe. Many of the men were reluctant to retire at all,

and were pressing in their desire to still "have a go" at the enemy. The retirement at last, after a two hours' struggle, was accomplished without undue loss. The 7th Battery, under command of Major Henshaw, made splendid practice. During the engagement Lord Dundonald sent a team of gun and waggon horses, under Captain Reed, to assist the 14th and 66th Batteries to recover their guns. Captain Reed returned to the 7th Battery, and though he came back with a bullet in his leg, he insisted on remaining with it until he was ordered back to camp.

Generals Buller and Clery were ubiquitous, riding coolly about and directing where the hurricane of lead was thickest, and running risks which rendered all who saw them anxious for their safety. Indeed, as some one remarked, one would have thought they were lieutenants trying to make a name, and not generals with the responsibility of an army on their minds. The loss of either of these prominent officers would have been counted by the Boers as a sign of victory, and therefore, when one was hit in the side and another in the arm by glancing bullets, there was considerable alarm among those who were near enough to observe what had taken place. Captain Hughes, R.A.M.C., was killed, and others of the Staff were wounded. Lord Gerard twice had narrow escapes, his horse being twice wounded.

A squadron of the Imperial Horse had an exciting experience. The men, who had dismounted to move in extended order across level country, were beginning to cross a ploughed field. Suddenly a rifle volley was opened upon them, and they were forced to lie down for cover. But the enemy, though on a kopje not 500 yards distant at this time, was quite invisible; and on this clear, hot day, though the song of the Mauser went on persistently, there was no smoke to betray the enemy's position. The Imperial Horse lay quiet, and the enemy thinking they were perhaps annihilated ceased firing. Presently, however, when the troopers ventured out, the firing was renewed, and many were killed and wounded. It is invidious to mention special regiments when all fought so resolutely. The behaviour of the irregular forces, however, was the subject of general remark. They held their position under a heavy cross-fire, refusing to retire without their wounded. And when they did retire, the movement was executed without flurry, with precision and composure, as if the battlefield were one vast manœuvring ground. Meanwhile the Boers still struggled to outflank our right, and the 13th Hussars had a lively time, Colonel Blagrove having his charger shot under him; but there were few serious calamities, only two of the troopers being killed.

[Pg 196]

Many instances of heroism were recorded on the part of men and officers belonging to all the regiments engaged in the battle. Lieutenant Ponsonby, of Thorneycroft's Horse, while endeavouring to save a wounded man, was fired at, the shot striking his unhappy burden and mortally wounding him. The young officer was slightly wounded himself, but managed to escape after shooting his assailant dead at very close quarters. The conduct of the Dublins was the subject of universal praise. They lost heavily; some 216 out of 900 men. When ordered to retire, although the crossing of the Tugela Drift was a sufficiently fearful experience, they were intensely disgusted. "Let us only see the beggars!" they asked. "Give us a chance with the bayonet!" said these gallant fellows, who had already passed through a hurricane of shot and shell. The Scottish Fusiliers lost 75 out of 301, but they were still ready, still bent, if allowed, upon carrying the bridge at all costs. Their enterprise was badly rewarded. They got left in an untenable position and were surrounded.

Captain Herbert, Staff Officer to Colonel Long, had his horse killed under him, while the Colonel himself was severely wounded by a bullet from a shrapnel shell. Captain White-Thomas, while on his way back to the limbers to get blankets for the injured, received a nasty wound. Colonel Brook (Connaught Rangers) was shot, and while being carried off the field by some of his men, one of these was wounded. The Colonel insisted on being put down, but Pat also insisted that he was equal to carrying his burden to a place of safety, and did so, though a shot had pierced his neck and passed clean out on the other side.

[Pg 197]

So many valiant deeds were performed that space will not admit of all being recounted. The irregulars and regulars seemed determined to out-distance each other in feats of chivalry. Private Farmer, of the Carabineers, struggled to save a comrade at the risk of his own life. Colour-Sergeant Byrne, in a storm of bullets, gallantly saved three of his comrades who were drowning, though he and they were heavily weighted with ammunition and equipment. Major Gordon, wounded as he was, fiercely and nobly led on his men till he dropped from exhaustion. The conduct of some of the drivers was simply amazing, and their daring was repeated and reflected in the achievements of the infantry. Quite wonderful was the bearing of these men, mere private soldiers, in their magnificent nobility of sacrifice, their utter regardlessness of self. Each strove to set an example to the other of steadfast, almost reckless devotion to duty.

The circumstances attending the capture of the guns were deeply tragic. Late in the terrible afternoon, when the red sun was sending horizontal rays across the blood-dyed field, a strong party of Boers swam the river for the purpose of seizing the guns and forcing the wounded, who were huddled together in the donga, to surrender. It was a fearful moment. Our worn-out, fainting, and dying men were lying about drenched in their own gore, helpless, and none could move to save the precious guns from falling into alien hands. Some raged, some wept with mortification at their powerlessness to stay the inevitable. Three Boers approached them for the purpose of demanding their instant surrender, and were shot at from the donga. A larger body then arrived, and though Colonel Bullock doggedly refused to surrender, and was struck down by their leader, they eventually forced the party to submit. It is said—let us hope it was mere report—that they threatened to shoot the wounded if they did not! However, the fact was mentioned by Sir Redvers Buller, who doubtless had been well informed on the subject.

The following is the list of casualties in the engagement at Colenso:—

Royal Field Artillery—Killed: Captain A. H. Goldie, Lieutenant C. B. Schreiber. Royal Dublin Fusiliers—Killed: Captain A. H. Bacon, Lieutenant P. C. Henry. Royal Inniskilling Fusiliers—Killed: Captain Frank C. Loftus. Devon Regiment—Wounded: Captain M. J. Goodwyn (b), Captain J. F. Radcliffe (b), Captain P. U. W. Vigor (c), Lieutenant H. B. W. Gardiner (c), Second Lieutenant H. J. Storey (c). Rifle Brigade—Wounded: Second Lieutenant R. G. Graham (b), Captain W. N. Congreve (c). Fifth Brigade Staff—Wounded: Captain Hon. St. Leger Jervis (b). Royal Inniskilling Fusiliers—Died of wounds: Major G. F. W. Charley. Wounded: Captain A. G. Hancocks (a), Captain W. F. Hessey (b), Captain E. J. Buckley (b), Lieutenant H. A. Levenson (b), Second Lieutenant T. W. Whiffen (b), Lieutenant A. D. Best (b), Lieutenant W. W. Weldon (c), Lieutenant J. G. Devenish (b). Border Regiment—Wounded: Major K. H. G. Heygate (b), Captain J. E. S. Probyn (c), Lieutenant G. T. Marsh (b). Connaught Rangers—Wounded: Colonel L. G. Brooke (a), Lieutenant G. F. Brooke (a). Royal Dublin Fusiliers.—Wounded: Major A. W. Gordon (b), Captain H. M. Stewan (b), Second Lieutenant M'Leod (b). Royal Irish Fusiliers—Wounded: Captain T. E. R. Brush (b). Royal Horse Artillery—Wounded: Colonel Long (a). Royal Field Artillery—Wounded: Lieut.-Colonel H. Hunt (c), Captain H. D. White-Thomson (c), Captain H. L. Reed (c), Captain F. A. G. Elton (b). Lieutenant Frank Goodson (c). Royal Army Medical Corps—Killed: Captain M. C. Hughes. Wounded: Major F. A. Bracington (? Brannigan) (c). Thorneycroft's Mounted Infantry— Killed: Lieutenant C. M. Jenkins. Wounded: Lieutenant W. Otto (b), Lieutenant Ponsonby (c), Second Lieutenant Holford, 19th Hussars (attached) (a). Natal Carabiniers—Wounded: D. W. Mackay (b), Lieutenant R. W. Wilson (c). South African Light Horse—Wounded: Lieutenant B. Banhurst (b), Lieutenant J. W. Cock (c). King's Royal Rifles— Wounded: Lieutenant Hon. F. H. S. Roberts (since died). Field Artillery—Prisoners: Second Lieutenant R. W. St. L. Gethin, Major A. L. Bailward, Lieutenant A. C. Birch, Second Lieutenant C. D. Holford, Major W. Y. Foster. Devon Regiment—Prisoners: Lieut.-Colonel G. Bullock, J. M'N. Walter, Lieutenant S. N. F. Smyth-Osbourne. Essex Regiment—Prisoner: Lieutenant W. F. Bonham. Royal Scots Fusiliers—Prisoners: Captain D. H. A. Dick, Captain H. H. Northy, Lieutenant E. Christian, Lieutenant E. F. H. Rumbold, Lieutenant M. E. M'Conaghey, Second Lieutenant G. E. Briggs. Royal Artillery—Missing: Lieutenant S. T. Butler. Connaught Rangers—Missing: Captain G. H. Ford-Hutchison, Second Lieutenant E. V. Jones.

[Pg 198]

(a) dangerously wounded; (b) seriously; (c) slightly.

Our losses were 1167 all told. Killed, 5 officers and 160 men; wounded, 36 officers and 634 men; missing and prisoners, 26 officers and 311 men—a terrible list for one day's work.



**THE BATTLE OF COLENZO—THE LAST
DESPERATE ATTEMPT TO SAVE THE
GUNS OF THE 14th and 66th
BATTERIES.**

Drawing by Sidney Paget.

Sad to state, our ambulances were designedly fired upon. Five shells fell in the neighbourhood of a waggon packed with wounded, and one party of ambulance men was forced twice to abandon their work of succour. The tents of the field-hospitals were no sooner erected than shells fell all round them, and the men were forced to desist from their labours. The heroic conduct of the civilian stretcher-bearers was generally the subject of remark. These men, though fired at by the enemy and injured, continued zealously to carry on their humane work, and assisted in saving many lives which might otherwise have been sacrificed. The force of the enemy opposed to us was estimated at 12,000 to 14,000. From a tactical standpoint the Boers had overwhelming advantages. Their numbers were immense, and the dangerous high-banked river, which they themselves had carefully dammed and filled with wire entanglements, made a formidable shield for the defensive party. In addition to this, they had constructed long, highly scientifically-arranged trenches, along which their Nordenfeldt gun could quickly travel, and thus defy any attempt of our gunners to get the range. Still the Naval guns were wonderfully worked, and wrought considerable havoc among the Boers in the over-hanging kopjes. Though their loss could not be accurately estimated, it was declared to be about 2000. The trenches were said to be choked with dead Dutchmen.

[Pg 199]

On the 16th of December an armistice was agreed upon, to last from noon till midnight, to enable both sides to collect and bury their dead.

The following "recommendations to notice" illuminated the somewhat sad nature of the General's despatch:—

"From the General Commanding-in-Chief the Forces in South Africa to the Secretary of State for War.

"SIR,—I have the honour to bring the following cases of Distinguished Service in the Field to your notice.

"At Colenso, on December 15, the detachments serving the guns of the 14th and 66th Batteries, Royal Field Artillery, had all been either killed, wounded, or driven from their guns by infantry fire at close range, and the guns were deserted.

"About 500 yards behind the guns was a donga, in which some of the few horses and drivers left alive were sheltered. The intervening space was swept with shell and rifle fire.

"Captain Congreve, Rifle Brigade, who was in the donga, assisted to hook a team into a limber, went out and assisted to limber up a gun; being wounded, he took shelter, but seeing Lieutenant Roberts fall badly wounded, he went out again and brought him in. Some idea of the nature of the fire may be gathered from the fact that Captain Congreve was shot through the leg, through the toe of his boot, grazed on the elbow and the shoulder, and his horse shot in three places.

"Lieutenant the Honourable F. Roberts, King's Royal Rifles, assisted Captain Congreve. He was wounded in three places.

"Corporal Nurse, Royal Field Artillery, 66th Battery, also assisted. I recommend the above three for the Victoria Cross.

"Drivers H. Taylor, Young, Petts, Rockall, Lucas, and Williams, all of the 66th Battery, Royal Field Artillery, rode the teams, each team brought in a gun. I recommend all six for the Medal for Distinguished Conduct in the Field.

"Shortly afterwards Captain H. L. Reed, 7th Battery, Royal Field Artillery, who had heard of the difficulty, brought down three teams from his battery to see if he could be of any use. He was wounded, as were five of the thirteen men who rode with him; one was killed, his body was found on the field, and thirteen out of twenty-one horses were killed before he got half-way to the guns, and he was obliged to retire.

"I recommend Captain Reed for the Victoria Cross, and the following non-commissioned officers and men, 7th Battery, Royal Field Artillery, for the Medal for Distinguished Service in the Field:—

"86,208 Corporal A. Clark, wounded; 87,652 Corporal R. J. Money; 82,210 Acting-Bombardier J. H. Reeve; 28,286 Driver C. J. Woodward; 22,054 Driver Wm. Robertson, wounded; 22,061 Driver Wm. Wright, wounded; 22,051 Driver A. C. Hawkins; 26,688 Driver John Patrick Lennox; 22,094 Driver Albert Nugent, killed; 23,294 Driver James Warden; 32,087 Driver Arthur Felton, wounded; 83,276 Driver Thomas Musgrove; 26,523 Trumpeter William W. Ayles, wounded.

"I have differentiated in my recommendations, because I thought that a recommendation for the Victoria Cross required proof of initiative, something more, in fact, than mere obedience to orders, and for this reason I have not recommended Captain Schofield, Royal Artillery, who was acting under orders, though I desire to record his conduct as most gallant.

"Several other gallant drivers tried, but were all killed, and I cannot get their names.—I have, &c.,

REDVERS BULLER, General."

Appended is an account of the battle given by Captain Walter Norris Congreve, one of the heroes of the day. It is deeply interesting, though it makes little reference to his own gallant action for which he gained the Victoria Cross:—

"Our big Naval guns shelled the enemy's position off and on all day, but could get no response. We could see very few Boers about, and it was a horrid position to attack.... I don't believe any troops could have taken it. However, we tried yesterday and failed. We bombarded every place that looked like holding Boers for two hours, without response and without a sign of a Boer. To see the shells bursting, you would have thought nothing could have been left alive in the vicinity. After this, infantry, which had already got into position, advanced line after line and extended widely. Instantly thousands of bullets began pattering about, and their guns pitched shells all over the place. Where they came from no one could see till the end. Sir Redvers Buller rode all along the line, and came in for a good deal of attention from bullets and shells.

"My first experience was my stick being knocked out of my hand by a bullet; then a horse beside me was killed by a shell. About 10 o'clock two batteries which had advanced far too close ran short of ammunition. Their waggons were about 800 yards behind, the horses and men sheltering in a deep narrow nullah. General Buller told them to take the waggons up to the battery, but instantly they emerged a stream of bullets and shells fell all round, and most of the men got into the nullah again. Generals Buller and Cleary stood out in it and said, 'Some of you go and help Schofield.' A.D.C. Roberts, myself, and two or three others went to the waggons, and we got two waggons horsed with the help of a corporal and six gunners. I have never seen even at field-firing the bullets fly thicker. All one could see were little tufts of dust all over the ground accompanied by a whistling noise, 'phut,' where they hit, and an increasing rattle of musketry somewhere in front.

"My first bullet went through my left sleeve and just made the point of my elbow bleed. Next a clod of earth caught me a smack on the other arm; then my horse got one; then my right leg one, and my horse another. That settled us, for he plunged, and I fell about 100 yards short of the guns we were going to. A little nullah was by, and into that I hobbled and sat down. I had not been in a minute before another bullet hit the toe of my boot, went into the welt, travelled up, and came out at the toe-cap, two inches from the end of the toe. It did not even scratch me, but I shifted my quarters pretty quickly to a better place, where I found Colonels Hunt and Long, R.A., and a dozen or so wounded gunners; a doctor, Colonel Bullock, and about fifteen men of his regiment—all that were left of the escort and two batteries.

"At about 11 o'clock the fire slackened, and I went out, finding poor Roberts badly wounded, and with help got him into the nullah. There we lay from 11 till 4.30: no water, not a breath of air, no particle of shade, and a sun which I have never felt hotter even in India. My jacket was taken to shade

Robert's head, and what with blood and dirt I was a pretty object by the time I got out. At 4.30 the Boers rode up and asked us to surrender, or they would shoot us all. Colonel Bullock was the senior unwounded officer, and had, perhaps, twenty rifles all told. He refused, and they at once began a fusillade from fifty yards distant, and our people returned it. It was unpleasant, and only a question of minutes before they enfiladed our trenches and bagged the lot. Bullock's men knocked over two, and they then put up a white flag, parleyed, said we might remove our wounded, and the remainder either be taken prisoners or fight it out. However, while we were talking 100 or so crept round us. We found loaded rifles at every armed man's head, and we were forced to give in. One of our ambulances came up, and we were gradually collected at one spot, and a colour-sergeant of the Devon Regiment carried me upon his back."

END OF VOLUME II.

Printed by BALLANTYNE, HANSON & Co.

Edinburgh & London

Facsimile of MS. of MR. RUDYARD KIPLING'S War Poem "THE ABSENT-MINDED BEGGAR"

The Absent-minded Beggar

I.

When you're shouted "Rule Britannia" - when you're sung "God Save The Queen" -
When you're finished killing Kruger with your mouth -
Will you kindly drop a shilling in my little tambourine
For a gentleman in Khartoum ordered South?
He's an absent-minded beggar and his neatnesses are great -
But we and Paul must take him as we find him -
He is out on active service, wiping something off a slate -
And he's left a lot o' little things behind him!
Ork's son - Cook's son - Son of a hundred Kings -
(Fifty thousand horse and foot going to Table Bay!)
Each of 'em doing his country's work (and who's to look after his things?)
Pass the hat for your credits' sake, and pay - pay - pay!

II.

Here are girls he married secret, asking no permission to,
For he knew he wouldn't get it if he died.
There is gas and coals and vittles and the housemaid falling due
And it's more than rather lately there's a kid
There are girls he walked with casual they'll be sorry now he's gone,
For an absent-minded beggar they will find him.
But it ain't the time for sermons with the winter coming on -
We must help the girl that Tommy's left behind him!
Ork's son - Ork's son - Son of a belted Earl -
Son of a dumbek publican - it's all the same today!
Each of 'em doing his country's work (and who's to look after the girl?)
Pass the hat for your credits' sake, and pay - pay - pay!

There are families by thousands. far too proud to beg or speak —
 And they'll put their shields and hiding up the spout,
 And they'll live on half o' nothing paid 'em punctual once a week.
 Cause the man that earned the wage is ordered out
 He's an absent minded beggar, but he heaved his country call,
 And his reg'ment didn't need to send to find him
 He checked his job and joined it — So the job before us all
 Is to help the home that Tommy's left behind him!
 Dute's job — Coe's job — gardener, baronet, groom —
 News or palace or paper. Shop — there's some one gone away!
 Each of 'em doing his country's work (and who's to look after the 'room?)
 Pass the hat for your credit's sake and — pay! pay! pay!

Let us manage so as later we can look 'em in the face,
 And tell him — what he'd very much prefer —
 That while he saved the Empire his employer saved his place,
 And his mates (that's you and me) looked out for her,
 Was an absent minded beggar, and he may forget it all,
 But we do not want his excuses to remind him
 That we sent 'em to the workhouse while their daddy hammered Paul
 So we'll help the homes our Tommy's left behind him!
 Coe's home — Dute's home — home of a millionaire.
 (With thousand horse and foot gang to Table Bay!)
 Each of 'em doing his country's work (and what have you got to spare?)
 Pass the hat for your credit's sake and — pay! pay! pay!

Rudyard Kipling

The above facsimile is printed by arrangement with the Daily Mail Publishing Co., London

TRANSCRIBERS' NOTES

General: Errors and inconsistencies in punctuation have been corrected without individual notes.

Pages vi, 6, 10: Drakenberg standardised to Drakensberg.

Page vii: repeated date 2 November removed.

Chart of Staff Appointments; Natal Field Force; 4th Division: Aides-de-Camp (2) blank in original

Chart of Staff Appointments; Staff of 1st Army Corps: Orderly Veterinary Officer blank in original

Chart of Staff Appointments; 1st Army Corps 3rd Division; 6th Brigade: Aide-de-Camp blank in original

Chart of Staff Appointments; Staff of Cavalry Division: Aides-de-Camp (2)—Only one listed in original

Page 32: rear-guard standardised to rearguard.

Pages 35, 36: Isandhlwana/Isandlwana has not been standardised as it is used as part of a quotation.

Page 37: viâ standardised to via. [N.B. other usages not standardised as part of a quotation.]

Page 44: Blue-jackets standardised to Bluejackets.

Page 45: similarly corrected to similarly.

Page 46: Brvant corrected to Bryant.

Page 51: fortunately corrected to fortunately.

Pages 53, 121: Nordenfelt standardised to Nordenfeldt.

Page 82: reconnaissance corrected to reconaissance.

Page 91: Comanding corrected to Commanding.

Pages 114, 148: debris/débris has not been standardised as it is used as part of a quotation.

Page 120: McLachlan standardised to M'Lachlan.

Page 145: comandeered corrected to commandeered.

Page 147: sandbags standardised to sand-bags.

Page 150: downhill standardised to down-hill.

Page 151: search-light standardised to searchlight.

Page 183: The quotation from Addison is actually incorrect. It should read:

"A thousand glorious actions, that might claim
Triumphant laurels, and immortal fame,
Confused in clouds of glorious actions lie,
And troops of heroes undistinguished die."

Page 185 (footnote): Gingindhlovo standardised to Gingindhlovu.

Page 187: Repeated "the" removed from "remained the the same".

*** END OF THE PROJECT GUTENBERG EBOOK SOUTH AFRICA AND THE TRANSVAAL WAR,
VOL. 2 (OF 8) ***

Updated editions will replace the previous one—the old editions will be renamed.

Creating the works from print editions not protected by U.S. copyright law means that no one owns a United States copyright in these works, so the Foundation (and you!) can copy and distribute it in the United States without permission and without paying copyright royalties. Special rules, set forth in the General Terms of Use part of this license, apply to copying and distributing Project Gutenberg™ electronic works to protect the PROJECT GUTENBERG™ concept and trademark. Project Gutenberg is a registered trademark, and may not be used if you charge for an eBook, except by following the terms of the trademark license, including paying royalties for use of the Project Gutenberg trademark. If you do not charge anything for copies of this eBook, complying with the trademark license is very easy. You may use this eBook for nearly any purpose such as creation of derivative works, reports, performances and research. Project Gutenberg eBooks may be modified and printed and given away—you may do practically ANYTHING in the United States with eBooks not protected by U.S. copyright law. Redistribution is subject to the trademark license, especially commercial redistribution.

START: FULL LICENSE
THE FULL PROJECT GUTENBERG LICENSE
PLEASE READ THIS BEFORE YOU DISTRIBUTE OR USE THIS WORK

To protect the Project Gutenberg™ mission of promoting the free distribution of electronic works, by using or distributing this work (or any other work associated in any way with the phrase "Project Gutenberg"), you agree to comply with all the terms of the Full Project Gutenberg™ License available with this file or online at www.gutenberg.org/license.

Section 1. General Terms of Use and Redistributing Project Gutenberg™ electronic works

1.A. By reading or using any part of this Project Gutenberg™ electronic work, you indicate that you have read, understand, agree to and accept all the terms of this license and intellectual property (trademark/copyright) agreement. If you do not agree to abide by all the terms of this agreement, you must cease using and return or destroy all copies of Project Gutenberg™ electronic works in your possession. If you paid a fee for obtaining a copy of or access to a Project Gutenberg™ electronic work and you do not agree to be bound by the terms of this agreement, you may obtain a refund from the person or entity to whom you paid the fee as set forth in paragraph 1.E.8.

1.B. "Project Gutenberg" is a registered trademark. It may only be used on or associated in any way with an electronic work by people who agree to be bound by the terms of this agreement. There are a few things that you can do with most Project Gutenberg™ electronic works even without complying with the full terms of this agreement. See paragraph 1.C below. There are a lot of things you can do with Project Gutenberg™ electronic works if you follow the terms of this agreement and help preserve free future access to Project Gutenberg™ electronic works. See paragraph 1.E below.

1.C. The Project Gutenberg Literary Archive Foundation ("the Foundation" or PGLAF), owns a compilation copyright in the collection of Project Gutenberg™ electronic works. Nearly all

the individual works in the collection are in the public domain in the United States. If an individual work is unprotected by copyright law in the United States and you are located in the United States, we do not claim a right to prevent you from copying, distributing, performing, displaying or creating derivative works based on the work as long as all references to Project Gutenberg are removed. Of course, we hope that you will support the Project Gutenberg™ mission of promoting free access to electronic works by freely sharing Project Gutenberg™ works in compliance with the terms of this agreement for keeping the Project Gutenberg™ name associated with the work. You can easily comply with the terms of this agreement by keeping this work in the same format with its attached full Project Gutenberg™ License when you share it without charge with others.

1.D. The copyright laws of the place where you are located also govern what you can do with this work. Copyright laws in most countries are in a constant state of change. If you are outside the United States, check the laws of your country in addition to the terms of this agreement before downloading, copying, displaying, performing, distributing or creating derivative works based on this work or any other Project Gutenberg™ work. The Foundation makes no representations concerning the copyright status of any work in any country other than the United States.

1.E. Unless you have removed all references to Project Gutenberg:

1.E.1. The following sentence, with active links to, or other immediate access to, the full Project Gutenberg™ License must appear prominently whenever any copy of a Project Gutenberg™ work (any work on which the phrase “Project Gutenberg” appears, or with which the phrase “Project Gutenberg” is associated) is accessed, displayed, performed, viewed, copied or distributed:

This eBook is for the use of anyone anywhere in the United States and most other parts of the world at no cost and with almost no restrictions whatsoever. You may copy it, give it away or re-use it under the terms of the Project Gutenberg License included with this eBook or online at www.gutenberg.org. If you are not located in the United States, you will have to check the laws of the country where you are located before using this eBook.

1.E.2. If an individual Project Gutenberg™ electronic work is derived from texts not protected by U.S. copyright law (does not contain a notice indicating that it is posted with permission of the copyright holder), the work can be copied and distributed to anyone in the United States without paying any fees or charges. If you are redistributing or providing access to a work with the phrase “Project Gutenberg” associated with or appearing on the work, you must comply either with the requirements of paragraphs 1.E.1 through 1.E.7 or obtain permission for the use of the work and the Project Gutenberg™ trademark as set forth in paragraphs 1.E.8 or 1.E.9.

1.E.3. If an individual Project Gutenberg™ electronic work is posted with the permission of the copyright holder, your use and distribution must comply with both paragraphs 1.E.1 through 1.E.7 and any additional terms imposed by the copyright holder. Additional terms will be linked to the Project Gutenberg™ License for all works posted with the permission of the copyright holder found at the beginning of this work.

1.E.4. Do not unlink or detach or remove the full Project Gutenberg™ License terms from this work, or any files containing a part of this work or any other work associated with Project Gutenberg™.

1.E.5. Do not copy, display, perform, distribute or redistribute this electronic work, or any part of this electronic work, without prominently displaying the sentence set forth in paragraph 1.E.1 with active links or immediate access to the full terms of the Project Gutenberg™ License.

1.E.6. You may convert to and distribute this work in any binary, compressed, marked up, nonproprietary or proprietary form, including any word processing or hypertext form. However, if you provide access to or distribute copies of a Project Gutenberg™ work in a format other than “Plain Vanilla ASCII” or other format used in the official version posted on the official Project Gutenberg™ website (www.gutenberg.org), you must, at no additional cost, fee or expense to the user, provide a copy, a means of exporting a copy, or a means of obtaining a copy upon request, of the work in its original “Plain Vanilla ASCII” or other form. Any alternate format must include the full Project Gutenberg™ License as specified in paragraph 1.E.1.

1.E.7. Do not charge a fee for access to, viewing, displaying, performing, copying or distributing any Project Gutenberg™ works unless you comply with paragraph 1.E.8 or 1.E.9.

1.E.8. You may charge a reasonable fee for copies of or providing access to or distributing Project Gutenberg™ electronic works provided that:

- You pay a royalty fee of 20% of the gross profits you derive from the use of Project Gutenberg™ works calculated using the method you already use to calculate your applicable

taxes. The fee is owed to the owner of the Project Gutenberg™ trademark, but he has agreed to donate royalties under this paragraph to the Project Gutenberg Literary Archive Foundation. Royalty payments must be paid within 60 days following each date on which you prepare (or are legally required to prepare) your periodic tax returns. Royalty payments should be clearly marked as such and sent to the Project Gutenberg Literary Archive Foundation at the address specified in Section 4, "Information about donations to the Project Gutenberg Literary Archive Foundation."

- You provide a full refund of any money paid by a user who notifies you in writing (or by e-mail) within 30 days of receipt that s/he does not agree to the terms of the full Project Gutenberg™ License. You must require such a user to return or destroy all copies of the works possessed in a physical medium and discontinue all use of and all access to other copies of Project Gutenberg™ works.
- You provide, in accordance with paragraph 1.F.3, a full refund of any money paid for a work or a replacement copy, if a defect in the electronic work is discovered and reported to you within 90 days of receipt of the work.
- You comply with all other terms of this agreement for free distribution of Project Gutenberg™ works.

1.E.9. If you wish to charge a fee or distribute a Project Gutenberg™ electronic work or group of works on different terms than are set forth in this agreement, you must obtain permission in writing from the Project Gutenberg Literary Archive Foundation, the manager of the Project Gutenberg™ trademark. Contact the Foundation as set forth in Section 3 below.

1.F.

1.F.1. Project Gutenberg volunteers and employees expend considerable effort to identify, do copyright research on, transcribe and proofread works not protected by U.S. copyright law in creating the Project Gutenberg™ collection. Despite these efforts, Project Gutenberg™ electronic works, and the medium on which they may be stored, may contain "Defects," such as, but not limited to, incomplete, inaccurate or corrupt data, transcription errors, a copyright or other intellectual property infringement, a defective or damaged disk or other medium, a computer virus, or computer codes that damage or cannot be read by your equipment.

1.F.2. LIMITED WARRANTY, DISCLAIMER OF DAMAGES - Except for the "Right of Replacement or Refund" described in paragraph 1.F.3, the Project Gutenberg Literary Archive Foundation, the owner of the Project Gutenberg™ trademark, and any other party distributing a Project Gutenberg™ electronic work under this agreement, disclaim all liability to you for damages, costs and expenses, including legal fees. YOU AGREE THAT YOU HAVE NO REMEDIES FOR NEGLIGENCE, STRICT LIABILITY, BREACH OF WARRANTY OR BREACH OF CONTRACT EXCEPT THOSE PROVIDED IN PARAGRAPH 1.F.3. YOU AGREE THAT THE FOUNDATION, THE TRADEMARK OWNER, AND ANY DISTRIBUTOR UNDER THIS AGREEMENT WILL NOT BE LIABLE TO YOU FOR ACTUAL, DIRECT, INDIRECT, CONSEQUENTIAL, PUNITIVE OR INCIDENTAL DAMAGES EVEN IF YOU GIVE NOTICE OF THE POSSIBILITY OF SUCH DAMAGE.

1.F.3. LIMITED RIGHT OF REPLACEMENT OR REFUND - If you discover a defect in this electronic work within 90 days of receiving it, you can receive a refund of the money (if any) you paid for it by sending a written explanation to the person you received the work from. If you received the work on a physical medium, you must return the medium with your written explanation. The person or entity that provided you with the defective work may elect to provide a replacement copy in lieu of a refund. If you received the work electronically, the person or entity providing it to you may choose to give you a second opportunity to receive the work electronically in lieu of a refund. If the second copy is also defective, you may demand a refund in writing without further opportunities to fix the problem.

1.F.4. Except for the limited right of replacement or refund set forth in paragraph 1.F.3, this work is provided to you 'AS-IS', WITH NO OTHER WARRANTIES OF ANY KIND, EXPRESS OR IMPLIED, INCLUDING BUT NOT LIMITED TO WARRANTIES OF MERCHANTABILITY OR FITNESS FOR ANY PURPOSE.

1.F.5. Some states do not allow disclaimers of certain implied warranties or the exclusion or limitation of certain types of damages. If any disclaimer or limitation set forth in this agreement violates the law of the state applicable to this agreement, the agreement shall be interpreted to make the maximum disclaimer or limitation permitted by the applicable state law. The invalidity or unenforceability of any provision of this agreement shall not void the remaining provisions.

1.F.6. INDEMNITY - You agree to indemnify and hold the Foundation, the trademark owner, any agent or employee of the Foundation, anyone providing copies of Project Gutenberg™ electronic works in accordance with this agreement, and any volunteers associated with the production, promotion and distribution of Project Gutenberg™ electronic works, harmless

from all liability, costs and expenses, including legal fees, that arise directly or indirectly from any of the following which you do or cause to occur: (a) distribution of this or any Project Gutenberg™ work, (b) alteration, modification, or additions or deletions to any Project Gutenberg™ work, and (c) any Defect you cause.

Section 2. Information about the Mission of Project Gutenberg™

Project Gutenberg™ is synonymous with the free distribution of electronic works in formats readable by the widest variety of computers including obsolete, old, middle-aged and new computers. It exists because of the efforts of hundreds of volunteers and donations from people in all walks of life.

Volunteers and financial support to provide volunteers with the assistance they need are critical to reaching Project Gutenberg™'s goals and ensuring that the Project Gutenberg™ collection will remain freely available for generations to come. In 2001, the Project Gutenberg Literary Archive Foundation was created to provide a secure and permanent future for Project Gutenberg™ and future generations. To learn more about the Project Gutenberg Literary Archive Foundation and how your efforts and donations can help, see Sections 3 and 4 and the Foundation information page at www.gutenberg.org.

Section 3. Information about the Project Gutenberg Literary Archive Foundation

The Project Gutenberg Literary Archive Foundation is a non-profit 501(c)(3) educational corporation organized under the laws of the state of Mississippi and granted tax exempt status by the Internal Revenue Service. The Foundation's EIN or federal tax identification number is 64-6221541. Contributions to the Project Gutenberg Literary Archive Foundation are tax deductible to the full extent permitted by U.S. federal laws and your state's laws.

The Foundation's business office is located at 809 North 1500 West, Salt Lake City, UT 84116, (801) 596-1887. Email contact links and up to date contact information can be found at the Foundation's website and official page at www.gutenberg.org/contact

Section 4. Information about Donations to the Project Gutenberg Literary Archive Foundation

Project Gutenberg™ depends upon and cannot survive without widespread public support and donations to carry out its mission of increasing the number of public domain and licensed works that can be freely distributed in machine-readable form accessible by the widest array of equipment including outdated equipment. Many small donations (\$1 to \$5,000) are particularly important to maintaining tax exempt status with the IRS.

The Foundation is committed to complying with the laws regulating charities and charitable donations in all 50 states of the United States. Compliance requirements are not uniform and it takes a considerable effort, much paperwork and many fees to meet and keep up with these requirements. We do not solicit donations in locations where we have not received written confirmation of compliance. To SEND DONATIONS or determine the status of compliance for any particular state visit www.gutenberg.org/donate.

While we cannot and do not solicit contributions from states where we have not met the solicitation requirements, we know of no prohibition against accepting unsolicited donations from donors in such states who approach us with offers to donate.

International donations are gratefully accepted, but we cannot make any statements concerning tax treatment of donations received from outside the United States. U.S. laws alone swamp our small staff.

Please check the Project Gutenberg web pages for current donation methods and addresses. Donations are accepted in a number of other ways including checks, online payments and credit card donations. To donate, please visit: www.gutenberg.org/donate

Section 5. General Information About Project Gutenberg™ electronic works

Professor Michael S. Hart was the originator of the Project Gutenberg™ concept of a library of electronic works that could be freely shared with anyone. For forty years, he produced and distributed Project Gutenberg™ eBooks with only a loose network of volunteer support.

Project Gutenberg™ eBooks are often created from several printed editions, all of which are confirmed as not protected by copyright in the U.S. unless a copyright notice is included. Thus, we do not necessarily keep eBooks in compliance with any particular paper edition.

Most people start at our website which has the main PG search facility: www.gutenberg.org.

This website includes information about Project Gutenberg™, including how to make

donations to the Project Gutenberg Literary Archive Foundation, how to help produce our new eBooks, and how to subscribe to our email newsletter to hear about new eBooks.