

The Project Gutenberg eBook of Manual of Military Training

This ebook is for the use of anyone anywhere in the United States and most other parts of the world at no cost and with almost no restrictions whatsoever. You may copy it, give it away or re-use it under the terms of the Project Gutenberg License included with this ebook or online at www.gutenberg.org. If you are not located in the United States, you'll have to check the laws of the country where you are located before using this eBook.

Title: Manual of Military Training

Author: James A. Moss

Release date: September 26, 2008 [eBook #26706]

Language: English

Credits: Produced by Brian Sogard, Chris Logan and the Online Distributed Proofreading Team at <http://www.pgdp.net>

*** START OF THE PROJECT GUTENBERG EBOOK MANUAL OF MILITARY TRAINING ***

Manual of Military Training

(SECOND, REVISED EDITION)

BY

COLONEL JAMES A. MOSS

UNITED STATES ARMY

(Officially adopted by ONE HUNDRED AND FIVE
[105] of our military schools and colleges.)

Intended, primarily, for use in connection with the instruction and training of Cadets in our military schools and colleges and of COMPANY officers of the National Army, National Guard, and Officers' Reserve Corps; and secondarily, as a guide for COMPANY officers of the Regular Army, the aim being to make efficient fighting COMPANIES and to qualify our Cadets and our National Army, National Guard and Reserve Corps officers for the duties and responsibilities of COMPANY officers in time of war.



Price \$2.25

GENERAL AGENTS

GEORGE BANTA PUBLISHING COMPANY

Army and College Printers

MENASHA—WISCONSIN

Copyright 1917

By

JAS. A. MOSS

FIRST EDITION	
First impression (October, 1914)	10,000
Second impression (September, 1915)	10,000
Third impression (March, 1916)	10,000
Fourth impression (July, 1916)	10,000
Fifth impression (February, 1917)	3,000
Sixth impression (April, 1917)	4,000

SECOND EDITION	
First impression (May, 1917)	40,000
Second impression (August, 1917)	30,000
Third impression (November, 1917)	50,000
Total	<u>167,000</u>

Publishers and General Distributors
GEORGE BANTA PUBLISHING CO., MENASHA, WIS.

OTHER DISTRIBUTERS

(Order from nearest one)

Boston, Mass. The Harding Uniform and Regalia Co., 22 School St.

Chicago, Ill. A. C. McClurg & Co.

Columbus, Ohio. The M. C. Lilley & Co.

Fort Leavenworth, Kan.

U. S. Cavalry Association.
Book Dept., Army Service Schools.

Fort Monroe, Va. Journal U. S. Artillery.

Kalamazoo, Mich. Henderson-Ames Co.

New York.

Baker & Taylor Co., 4th Ave.
Army and Navy Coöperative Co., 16 East 42nd St.
Ridabock & Co., 140 West 36th St.
Warnock Uniform Co., 16 West 46th St.

Philadelphia, Pa. Jacob Reed's Sons, 1424 Chestnut.

Portland, Ore. J. K. Gill Co.

San Antonio, Tex. Frank Brothers Alamo Plaza.

San Francisco, Cal. B. Pasquale Co., 115-117 Post St.

Washington, D. C.

Army and Navy Register, 511 Eleventh St. N. W.
Meyer's Military Shops, 1331 F. St. N. W.
U. S. Infantry Association, Union Trust Bldg.

PHILIPPINE ISLANDS: Philippine Education Co., Manila, P. I.

HAWAIIAN ISLANDS: Hawaiian News Co., Honolulu, H. T.

CANAL ZONE: Post Exchange, Empire, C. Z.

NOTE

In order to learn thoroughly the contents of this manual it is suggested that you use in connection with your study of the book the pamphlet, "QUESTIONS ON MANUAL OF MILITARY TRAINING," which, by means of questions, brings out and emphasizes every point mentioned in the manual.

"QUESTIONS ON MANUAL OF MILITARY TRAINING" is especially useful to students of schools and colleges using the manual, as it enables them, as nothing else will, to prepare for recitations and examinations.

The pamphlet can be gotten from the publishers, Geo. Banta Publishing Co., Menasha, Wis., or from any of the distributors of "MANUAL OF MILITARY TRAINING." Price 50 cts., postpaid.

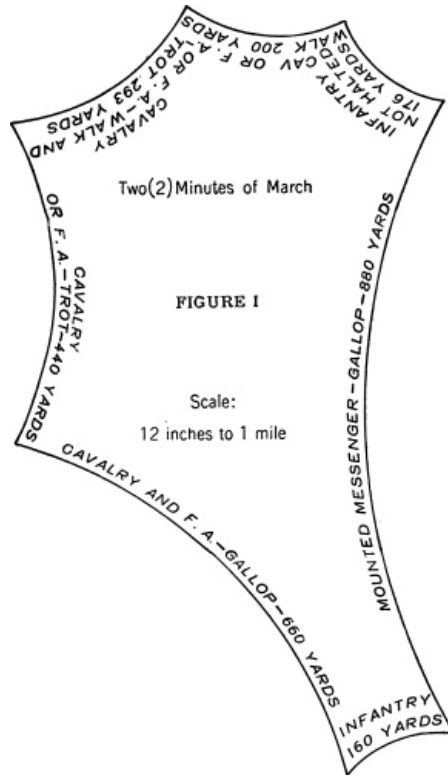

Cover Insert Fig. I

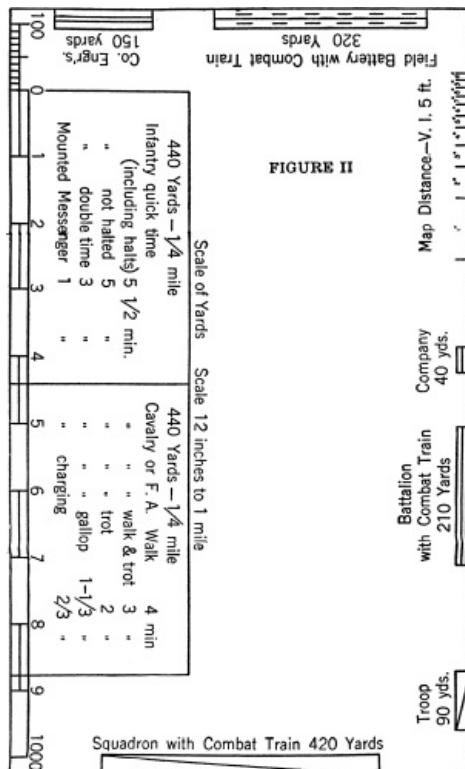

Cover Insert Fig. II

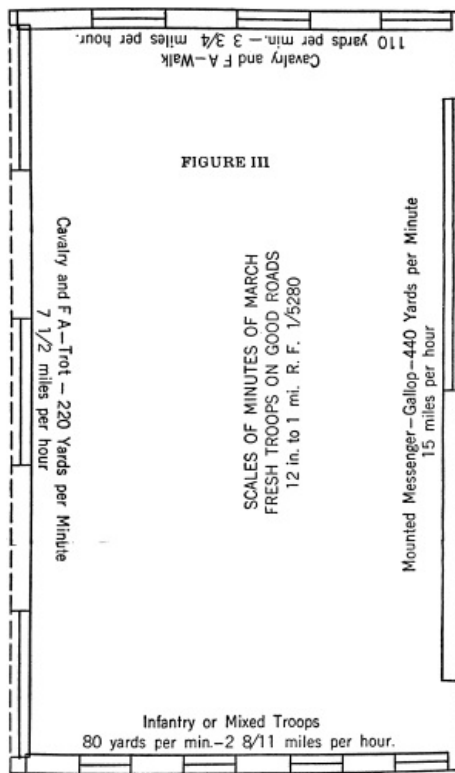

Cover Insert Fig. III

PREFATORY

Not only does this manual cover all the subjects prescribed by War Department orders for the Junior Division, and the Basic Course, Senior Division, of the Reserve Officers' Training Corps, but it also contains considerable additional material which broadens its scope, rounding it out and making it answer the purpose of a general, all-around book, complete in itself, for training and instruction in the fundamentals of the art of war.

The Company is the *basic fighting tactical unit*—it is the foundation rock upon which an army is built—and the fighting efficiency of a COMPANY is based on systematic and thorough training.

This manual is a presentation of MILITARY TRAINING as manifested in the training and instruction of a COMPANY. The book contains all the essentials pertaining to the training and instruction of COMPANY officers, noncommissioned officers and privates, and the officer who masters its contents and who makes his COMPANY proficient in the subjects embodied herein, will be in every way qualified, *without the assistance of a single other book*, to command with credit and satisfaction, in peace and in war, a COMPANY that will be an *efficient fighting weapon*.

This manual, as indicated below, is divided into a Prelude and nine Parts, subjects of a similar or correlative nature being thus grouped together.

PRELUDE.	THE OBJECT AND ADVANTAGES OF MILITARY TRAINING.
PART I.	DRILLS, EXERCISES, CEREMONIES, AND INSPECTIONS.
PART II.	COMPANY COMMAND.
PART III.	MISCELLANEOUS SUBJECTS PERTAINING TO COMPANY TRAINING AND INSTRUCTION.
PART IV.	RIFLE TRAINING AND INSTRUCTION.
PART V.	HEALTH AND KINDRED SUBJECTS.
PART VI.	MILITARY COURTESY AND KINDRED SUBJECTS.
PART VII.	GUARD DUTY.
PART VIII.	MILITARY ORGANIZATION.
PART IX.	MAP READING AND SKETCHING.

A schedule of training and instruction covering a given period and suitable to the local conditions that obtain in any given school or command, can be readily arranged by looking over the TABLE OF CONTENTS, and selecting therefrom such subjects as it is desired to use, the number and kind, and the time to be devoted to each, depending upon the time available, and climatic and other conditions.

It is suggested that, for the sake of variety, in drawing up a program of instruction and training, when practicable a part of each day or a part of each drill time, be devoted to theoretical work and a part to practical work, theoretical work, when possible, being followed by corresponding practical work, the practice (the *doing* of a thing) thus putting a clincher, as it were, on the theory (the explaining of a thing). The theoretical work, for example, could be carried on in the

forenoon and the practical work in the afternoon, or the theoretical work could be carried on from, say, 8 to 9:30 a. m., and the practical work from 9:30 to 10:30 or 11 a. m.

Attention is invited to the completeness of the Index, whereby one is enabled to locate at once any point covered in the book.

ACKNOWLEDGMENT

The author wishes to acknowledge the assistance received in the revision of this Manual in the form of suggestions from a large number of officers on duty at our military schools and colleges, suggestions that enabled him not only to improve the Manual in subject-matter as well as in arrangement, but that have also enabled him to give our military schools and colleges a textbook which, in a way, may be said to represent the consensus of opinion of our Professors of Military Science and Tactics as to what such a book should embody in both subject-matter and arrangement.

Suggestions received from a number of Professors of Military Science and Tactics show conclusively that local conditions as to average age and aptitude of students, interest taken in military training by the student body, support given by the school authorities, etc., are so different in different schools that it would be impossible to write a book for general use that would, in amount of material, arrangement and otherwise, just exactly fit, in toto, the conditions, and meet the requirements of each particular school.

Therefore, the only practical, satisfactory solution of the problem is to produce a book that meets *all* the requirements of the strictly military schools, where the conditions for military training and instruction are the most favorable, and the requirements the greatest, and then let other schools take only such parts of the book as are necessary to meet their own particular local needs and requirements.

"MANUAL OF MILITARY TRAINING" is such a book.



Camp Gaillard, C. Z.,
March 4, 1917.

TABLE OF CONTENTS

[Pg 6]

	Par. No.
PRELUDE	
OBJECT AND ADVANTAGES OF MILITARY TRAINING	
Object of: Setting-Up Exercises, Calisthenics, Facings and Marchings, Saluting, Manual of Arms, School of the Squad, Company Drill, Close Order, Extended Order, Ceremonies, Discipline— Advantages: Handiness, Self-Control, Loyalty, Orderliness, Self-Confidence, Self-Respect, Training Eyes, Teamwork, Heeding Law and Order, Sound Body.	1-23
PART I	
CHAPTER I.	
INFANTRY DRILL REGULATIONS —Definitions—General Remarks—General Rules for Drills and Formations—Orders, Commands, and Signals—School of the Soldier—School of the Squad—School of the Company—School of the Battalion—Combat—Leadership—Combat Reconnaissance—Fire Superiority—Fire Direction and Control—Deployment—Attack—Defense—Meeting Engagements—Machine Guns—Ammunition Supply—Mounted Scouts—Night Operations—Infantry Against Cavalry—Infantry Against Artillery—Artillery Supports—Minor Warfare—Ceremonies—Inspections—Muster—The Color—Manual of the Saber—Manual of Tent	24- 710

CHAPTER II.	Pitching—Appendices A and B. MANUAL OF THE BAYONET —Nomenclature and Description of the Bayonet—Instruction without the Rifle—Instruction with the Rifle—Instruction without the Bayonet—Combined Movements—Fencing Exercises—Fencing at Will—Lessons of the European War—The "Short point"—The "Jab."	711- 824
CHAPTER III.	MANUAL OF PHYSICAL TRAINING —Methods—Commands—Setting-Up Exercises—Rifle Exercises.	825- 860
CHAPTER IV.	SIGNALING —General Service Code—Wigwag—The Two-Arm Semaphore Code—Signaling with Heliograph, Flash Lanterns, and Searchlight—Sound Signals—Morse Code.	861- 866

[Pg 7]

PART II

COMPANY COMMAND

CHAPTER I.	GOVERNMENT AND ADMINISTRATION OF A COMPANY —Duties and Responsibilities of the Captain and the Lieutenants—Devolution of Work and Responsibility—Duties and Responsibilities of the First Sergeant and other Noncommissioned Officers—Contentment and Harmony—Efficacious Forms of Company Punishment—Property Responsibility—Books and Records.	867- 909
CHAPTER II.	DISCIPLINE —Definition—Methods of Attaining Good Discipline—Importance—Sound Discipline—Punishment—General Principles.	910- 916

PART III

MISCELLANEOUS SUBJECTS PERTAINING TO COMPANY TRAINING AND INSTRUCTION

CHAPTER I.	GENERAL PRINCIPLES OF COMPANY TRAINING AND INSTRUCTION —Object of Training and Instruction—Method and Progression—Individual Initiative—The Human Element—Art of Instruction on the Ground—Ocular Demonstration.	917- 941
CHAPTER II.	GENERAL COMMON SENSE PRINCIPLES OF APPLIED MINOR TACTICS —Art of War Defined—Responsibilities of Officers and Noncommissioned Officers in War—General Rules and Principles of Map Problems, Terrain Exercises, the War Game, and Maneuvers—Estimating the Situation—Mission.	942- 953
CHAPTER III.	GENERAL PLAN OF INSTRUCTION IN MAP PROBLEMS FOR NONCOMMISSIONED OFFICERS AND PRIVATES—INSTRUCTION IN DELIVERING MESSAGES.	954- 958
CHAPTER IV.	THE SERVICE OF INFORMATION —General Principles of Patrolling—Sizes of Patrols—Patrol Leaders—Patrol Formations—Messages and Reports—Suggestions for Gaining Information about the Enemy—Suggestions for the Reconnaissance of Various Positions and Localities—Demolitions—Problems in Patrolling.	959- 1019
CHAPTER V.	THE SERVICE OF SECURITY —General principles—Advance Guard—Advance Guard Problems—Flank Guards—Rear Guard—Outposts—Formation of Outposts—Outguards—Flags of Truce—Detached Posts—Examining Posts—Establishing the Outpost—Outpost Order—Intercommunication—Outpost Problems.	1020- 1079
CHAPTER VI.	THE COMPANY ON OUTPOST —Establishing the Outpost.	1080
CHAPTER VII.	THE COMPANY IN SCOUTING AND PATROLLING —Requisites of a Good Scout—Eyesight and hearing—Finding Way in Strange Country—What to do when Lost—Landmarks—Concealment and Dodging—Tracking—The Mouse and Cat Contest—Flag Stealing Contest.	1081- 1090
CHAPTER VIII.	NIGHT OPERATIONS —Importance—Training of the Company—Individual Training—Collective Training—Outposts.	1091- 1108
CHAPTER IX.	FIELD ENGINEERING —Bridges—Corduoying—Tascines—Hurdles—Brush Revetment—Gabions—Other Revetments—Knots—Lashings.	1109- 1139
CHAPTER X.	FIELD FORTIFICATIONS —Object—Classification—Hasty Intrenchments—Lying Trench—Kneeling Trench—Standing Trench—Deliberate Intrenchments—Fire Trenches—	1140- 1172

[Pg 8]

	Traverses—Trench recesses; sortie steps—Parados—Head Cover—Notches and Loopholes—Cover Trenches—Dugouts—Communicating Trenches—Lookouts—Supporting Points—Example of Trench System—Location of Trenches—Concealment of Trenches—Dummy Trenches—Length of Trench—Preparation of Foreground—Revetments—Drainage—Water Supply—Latrines—Illumination of the foreground—Telephones—Siege Works.		
CHAPTER XI.	OBSTACLES —Object—Necessity for Obstacles—Location—Abatis—Palisades—Fraises—Cheveaux de Frise—Obstacles against Cavalry—Wire Entanglements—Time and Materials—Wire Fence—Military Pits or Trou de Loup—Miscellaneous Barricades—Inundations—Obstacles in Front of Outguards—Lessons from the European War—Wire Cheveaux de Frise—Guarding Obstacles—Listening Posts—Automatic Alarms—Search Lights.	1173- 1193	[Pg 9]
CHAPTER XII.	TRENCH AND MINE WARFARE —Asphyxiating Gases—Protection against Gases—Liquid Fire—Grenades—Bombs—Aerial Mines—Winged Torpedoes—Bombs from Air-Craft—Protection against Hand Grenades—Tanks—Helmets—Masks—Periscopes—Sniperscopes—Aids to Firing—Mining—Countermining.	1194- 1211	
CHAPTER XIII.	MARCHES —Marching Principal Occupation of Troops in Campaign—Physical Training Hardening New Troops—Long Marches Not to Be Made with Untrained Troops—A Successful March—Preparation—Starting—Conduct of March—Rate—Marching Capacity—Halts—Crossing Bridges and Fords—Straggling and Elongation of Column—Forced Marches—Night Marches—No Compliments Paid on March—Protection on March—Fitting of Shoes and Care of Feet.	1212- 1229	
CHAPTER XIV.	CAMPS —Selection of Camp Sites—Desirable Camp Sites—Undesirable Camp Sites—Form and Dimensions of Camps—Making Camp—Retreat in Camp—Parade Ground—Windstorms—Making Tent Poles and Pegs Fast in Loose Soil—Trees.	1230- 1240	
CHAPTER XV.	CAMP SANITATION —Definition—Camp Expedients—Latrines—Urinal Tubs—Kitchens—Kitchen Pits—Incinerators—Drainage—Avoiding Old Camp Sites—Changing Camp Sites—Bunks—Wood—Water—Rules of Sanitation—Your Camp, Your Home.	1241- 1255	
CHAPTER XVI.	INDIVIDUAL COOKING —Making Fire—Recipes—Meats—Vegetables—Drinks—Hot Breads—Emergency Ration.	1256- 1275	
CHAPTER XVII.	CARE AND PRESERVATION OF CLOTHING AND EQUIPMENT —Clothing—Pressing—Removing Stains—Shoes—Cloth Equipment—Washing—Shelter Tent—Mess Outfit—Leather Equipment—Points to Be Remembered.	1276- 1320	[Pg 10]
CHAPTER XVIII.	CARE AND DESCRIPTION OF THE RIFLE —Importance—Care of Bore—How to Remove Fouling—Care of Mechanism and Various Parts—How to Apply Oil—Army Regulation Paragraphs About Rifle—Nomenclature of Rifle.	1321- 1343	

PART IV

RIFLE TRAINING AND INSTRUCTION

Object and Explanation of Our System of Instruction—	1344-
Individual Instruction—Theory of Sighting—Kinds of Sights—	1450
Preliminary Drills—Position and Aiming Drills—Deflection and Elevation Correction Drills—Gallery Practice—Range Practice—Use of Sling—Designation of Winds—Zero of Rifle—	
Estimating Distances—Wind—Temperature—Light—Mirage—	
Combat Practice—Fire Discipline—Technical Principles of Firing—Ballistic Qualities of the Rifle—Cone of Fire—Shot Group—Center of Impact—Beaten Zone—Zone of Effective Fire—Effectiveness of Fire—Influence of Ground—Grazing Fire—Ricochet Shots—Occupation of Ground—Adjustment of Fire—Determination of Range—Combined Sights—Auxiliary Aiming Points—Firing at Moving Targets—Night Firing—Fire Direction and Control—Distribution of Fire—Individual Instruction in Fire Distribution—Designation of Targets—	
Exercises in Ranging, Target Designation Communication, etc.	

PART V

CARE OF HEALTH AND KINDRED SUBJECTS

- CHAPTER I. CARE OF THE HEALTH**—Importance of Good Health—Germ—The Five Ways of Catching Disease—Diseases Caught by Breathing in Germs—Diseases Caught by Swallowing Germs—Disease Caught by Touching Germs—Diseases Caught from Biting Insects. [1451-1469](#)
- CHAPTER II. PERSONAL HYGIENE**—Keep the Skin Clean—Keep the Body Properly Protected against the Weather—Keep the Body Properly Fed—Keep the Body Supplied with Fresh Air—Keep the Body well Exercised—Keep the Body Rested by Sufficient Sleep—Keep the Body Free of Wastes. [1470-1477](#)
- CHAPTER III. FIRST AID TO THE SICK AND INJURED**—Object of Teaching First Aid—Asphyxiation by Gas—Bite of Dog—Bite of Snake—Bleeding—Broken Bones (Fractures)—Burns—Bruises—Cuts—Dislocations—Drowning—Electric Shock—Fainting—Foreign Body in Eye, in Ear—Freezing—Frost Bite—Headache—Heat Exhaustion—Poison—Sprains—Sunburn—Sunstroke—Wounds—Improvised Litters. [1478-1522](#)

[Pg 11]

PART VI

MILITARY COURTESY AND KINDRED SUBJECTS

- CHAPTER I. MILITARY DEPARTMENT AND APPEARANCE—PERSONAL CLEANLINESS—FORMS OF SPEECH—DELIVERY OF MESSAGES.** [1523-1531](#)
- CHAPTER II. MILITARY COURTESY**—Its Importance—Nature of Salutes and Their Origin—Whom to Salute—When and How to Salute—Usual Mistakes in Saluting—Respect to Be Paid the National Anthem, the Colors and Standards. [1532-1575](#)

PART VII

GUARD DUTY

- Importance—Respect for Sentinels—Classification of Guards—General Rules—The Commanding Officer—The Officer of the Day—The Commander of the Guard—Sergeant of the Guard—Corporal of the Guard—Musicians of the Guard—Orderlies and Color Sentinels—Privates of the Guard—Countersigns and Paroles—Guard Patrols—Compliments from Guards—General Rules Concerning Guard Duty—Stable Guards—Troop Stable Guards—Reveille and Retreat Gun—Formal Guard Mounting—Informal Guard Mounting. [1576-1857](#)

[Pg 12]

PART VIII

MILITARY ORGANIZATION

- Composition of Infantry, Cavalry and Field Artillery Units up to and Including the Regiment. [1858](#)

PART IX

MAP READING AND SKETCHING

- CHAPTER I. MAP READING**—Definition of Map—Ability to Read a Map—Scales—Methods of Representing Scales—Construction of Scales—Scale Problems—Scaling Distances from a Map—Contours—Map Distances—Slopes—Meridians—Determination of Positions of Points on Map—Orientation—Conventional Signs—Visibility. [1859-1877](#)
- CHAPTER II. MILITARY SKETCHING**—The Different Methods of Sketching—Location of Points by Intersection—Location of points by Resection—Location of Points by Traversing—Contours—Form Lines—Scales—Position Sketching—Outpost Sketching—Road Sketching—Combined Sketching—Points for Beginners to Remember. [1878-1893](#)

THE OBJECT AND ADVANTAGES OF MILITARY TRAINING

1. Prelude. We will first consider the object and advantages of military training, as they are the natural and logical prelude to the subject of military training and instruction.

Object

2. The object of all military training is to win battles.

Everything that you do in military training is done with some immediate object in view, which, in turn, has in view the *final* object of winning battles. For example:

3. Setting-up exercises. The object of the setting-up exercises, as the name indicates, is to give the new men the *set-up*,—the bearing and carriage,—of the military man.

In addition these exercises serve to loosen up his muscles and prepare them for his later experiences and development.

4. Calisthenics. Calisthenics may be called the big brother, the grown-up form, of the setting-up exercise.

The object of calisthenics is to develop and strengthen all parts and muscles of the human body,—the back, the legs, the arms, the lungs, the heart and all other parts of the body.

First and foremost a fighting man's work depends upon his physical fitness.

To begin with, a soldier's mind must always be on the alert and equal to any strain, and no man's mind can be at its best when he is handicapped by a weak or ailing body.

The work of the fighting man makes harsh demands on his body. It must be strong enough to undergo the strain of marching when every muscle cries out for rest; strong enough to hold a rifle steady under fatigue and excitement; strong enough to withstand all sorts of weather, and the terrible nervous and physical strain of modern battle; and more, it must be strong enough to resist those diseases of campaign which kill more men than do the bullets of the enemy.

Hence the necessity of developing and strengthening every part and muscle of the body.

5. Facings and Marchings. The object of the facings and marchings is to give the soldier complete control of his body in drills, so that he can get around with ease and promptness at every command.

The marchings,—the military walk and run,—also teach the soldier how to get from one place to another in campaign with the least amount of physical exertion.

Every man knows how to walk and run, but few of them how to do so without making extra work of it. One of the first principles in training the body of the soldier is to make each set of muscles do its own work and save the strength of the other muscles for their work. Thus the soldier marches in quick time,—walks,—with his legs, keeping the rest of his body as free from motion as possible. He marches in double time,—runs,—with an easy swinging stride which requires no effort on the part of the muscles of the body.

[Pg 14]

The marchings also teach the soldier to walk and run at a steady gait. For example, in marching in quick time, he takes 120 steps each minute; in double time, he takes 180 per minute.

Furthermore, the marchings teach the soldier to walk and run with others,—that is, in a body.

6. Saluting. The form of salutation and greeting for the civilian consists in raising the hat.

The form of salutation and greeting for the military man consists in rendering the military salute,—a form of salutation which marks you as a member of the Fraternity of Men-at-arms, men banded together for national defense, bound to each other by love of country and pledged to the loyal support of its symbol, the Flag. For the full significance of the military salute see [paragraph 1534](#).

7. Manual of Arms. The rifle is the soldier's fighting weapon and he must become so accustomed to the *feel* of it that he handles it without a thought,—just as he handles his arms or legs without a thought,—and this is what the manual of arms accomplishes.

The different movements and positions of the rifle are the ones that experience has taught are the best and the easiest to accomplish the object in view.

8. School of the Squad. The object of squad drill is to teach the soldier his first lesson in *team-work*,—and team-work is the thing that wins battles.

In the squad the soldier is associated with seven other men with whom he drills, eats, sleeps,

marches, and fights.

The squad is the unit upon which all of the work of the company depends. Unless the men of each squad work together as a single man,—unless there is *team-work*,—the work of the company is almost impossible.

9. Company Drill. Several squads are banded together into a company,—the basic fighting unit. In order for a company to be able to comply promptly with the will of its commander, it must be like a pliable, easily managed instrument. And in order to win battles a company on the firing line must be able to comply promptly with the will of its commander.

The object of company drill is to get such team-work amongst the squads that the company will at all times move and act like a pliable, easily managed whole.

10. Close Order. In close order drill the strictest attention is paid to all the little details, all movements being executed with the greatest precision. The soldiers being close together,—in *close order*,—they form a compact body that is easily managed, and consequently that lends itself well to teaching the soldier habits of attention, precision, team-work and instant obedience to the voice of his commander.

In order to control and handle bodies of men quickly and without confusion, they must be taught to group themselves in an orderly arrangement and to move in an orderly manner. For example, soldiers are grouped or formed in line, in column of squads, column of files, etc.

In close order drill soldiers are taught to move in an orderly manner from one group or formation to another; how to stand, step off, march, halt and handle their rifles all together.

[Pg 15]

This practice makes the soldier feel perfectly at home and at ease in the squad and company. He becomes accustomed to working side by side with the man next to him, and, unconsciously, both get into the habit of working together, thus learning the first principles of *team-work*.

11. Extended Order. This is the fighting drill.

Modern fire arms have such great penetration that if the soldiers were all bunched together a single bullet might kill or disable several men and the explosion of a single shell might kill or disable a whole company. Consequently, soldiers must be scattered,—*extended out*,—to fight.

In extended order not only do the soldiers furnish a smaller target for the enemy to shoot at, but they also get room in which to fight with greater ease and freedom.

The object of extended order drill is to practice the squads in team-work by which they are welded into a single fighting machine that can be readily controlled by its commander.

12. Parades, reviews, and other ceremonies. Parades, reviews and other ceremonies, with their martial music, the presence of spectators, etc., are intended to stimulate the interest and excite the military spirit of the command. Also, being occasions for which the soldiers dress up and appear spruce and trim, they inculcate habits of tidiness,—they teach a lesson in cleanliness of body and clothes.

While it is true it may be said that parades, reviews and other ceremonies form no practical part of the fighting man's training for battle, they nevertheless serve a very useful purpose in his general training. In these ceremonies in which soldiers march to martial music with flags flying, moving and going through the manual of arms with perfect precision and unison, there results a concerted movement that produces a feeling such as we have when we dance or when we sing in chorus. In other words, ceremonies are a sort of "get-together" exercise which pulls men together in spite of themselves, giving them a shoulder-to-shoulder feeling of solidity and power that helps to build up that confidence and spirit which wins battles.

13. Discipline. By discipline we mean the *habit* of observing all rules and regulations and of obeying promptly all orders. By observing day after day all rules and regulations and obeying promptly all orders, it becomes second nature,—a fixed habit,—to do these things.

Of course, in the Army, like in any other walk of life, there must be law and order, which is impossible unless everyone obeys the rules and regulations gotten up by those in authority.

When a man has cultivated the habit of obeying,—when obedience has become second nature with him,—he obeys the orders of his leaders instinctively, even when under the stress of great excitement, such as when in battle, his own reasoning is confused and his mind is not working.

In order to win a battle the *will* of the commander as expressed through his subordinates down the line from the second in command to the squad leaders, must be carried out by everyone. Hence the vital importance of prompt, instinctive obedience on the part of everybody, and of discipline, which is the mainspring of obedience and also the foundation rock of law and order.

[Pg 16]

And so could we go on indefinitely pointing out the object of each and every requirement of military training, for there is none that has no object and that answers no useful purpose, although the object and purpose may not always be apparent to the young soldier.

Advantages of Military Training

The following are the principal advantages of military training:

14. Handiness. The average man does one thing well. He is more or less apt to be clumsy about doing other things. The soldier is constantly called upon to do all sorts of things, and he has to do all of them well. His hands thus become trained and useful to him, and his mind gets into the habit of making his hands do what is required of them,—that is to say, the soldier becomes handy.

Handy arms are a valuable asset.

15. Self-control. In the work of the soldier, control does not stop with the hands.

The mind reaches out,—control of the body becomes a habit. The feet, legs, arms and body gradually come under the sway of the mind. In the position of the soldier, for instance, the mind holds the body motionless. In marching, the mind drives the legs to machine-like regularity. In shooting, the mind assumes command of the arms, hands, fingers and eye, linking them up and making them work in harmony.

Control of the body, together with the habit of discipline that the soldier acquires, leads to control of the mind,—that is, to *self-control*.

Self-control is an important factor in success in any walk of life.

16. Loyalty. Loyalty to his comrades, to his company, to his battalion, to his regiment becomes a religion with the soldier. They are a part of his life. Their reputation is his; their good name, his good name; their interests, his interests,—so, loyalty to them is but natural, and this loyalty soon extends to loyalty in general.

When you say a man is loyal the world considers that you have paid him a high tribute.

17. Orderliness. In the military service order and system are watchwords. The smooth running of the military machine depends on them.

The care and attention that the soldier is required to give at all times to his clothes, accouterments, equipment and other belongings, instill in him habits of orderliness.

Orderliness increases the value of a man.

18. Self-confidence and self-respect. Self-confidence is founded on one's ability to do things. The soldier is taught to defend himself with his rifle, and to take care of himself and to do things in almost any sort of a situation, all of which gives him confidence in himself,—*self-confidence*.

Respect for constituted authority, which is a part of the soldier's creed, teaches him respect for himself,—*self-respect*.

Self-confidence and self-respect are a credit to any man.

[Pg 17]

19. Eyes trained to observe. Guard duty, outpost duty, patrolling, scouting and target practice, train both the eye and the mind to observe.

Power of observation is a valuable faculty for a man to possess.

20. Teamwork. In drilling, patrolling, marching, maneuvers and in other phases of his training and instruction, the soldier is taught the principles of team-work,—coöperation,—whose soul is *loyalty*, a trait of every good soldier.

Teamwork,—coöperation,—leads to success in life.

21. Heeding law and order. The cardinal habit of the soldier is obedience. To obey orders and regulations is a habit with the soldier. And this habit of obeying orders and regulations teaches him to heed law and order.

The man who heeds law and order is a welcome member of any community.

22. Sound body. Military training, with its drills, marches, and other forms of physical exercise, together with its regular habits and outdoor work, keeps a man physically fit, giving him a sound body.

A sound body, with the physical exercise and outdoor life of the soldier, means good digestion, strength, hardiness and endurance.

A sound body is, indeed, one of the greatest blessings of life.

The Trained Soldier

23. Look at the trained soldier on the following page; study him carefully from top to bottom, and see what military training does for a man.

THE TRAINED SOLDIER

[Pg 18]

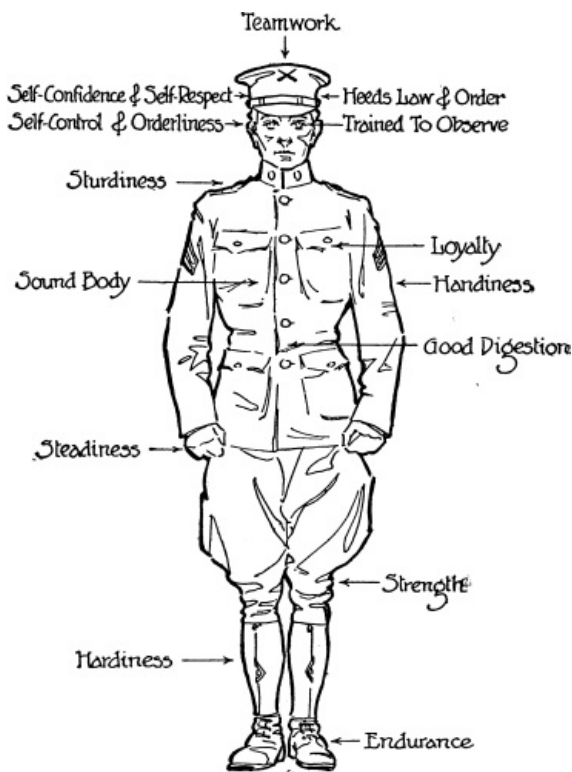

WHAT DO YOU THINK OF HIM, EH?

PART I

[Pg 19]

DRILLS, EXERCISES, CEREMONIES AND INSPECTIONS

CHAPTER I

[Pg 20]

INFANTRY DRILL REGULATIONS

(To include Changes No. 20, Aug. 18, 1917.)

DEFINITIONS

(The numbers following the paragraphs are those of the Drill Regulations, and references in the text to certain paragraph numbers refer to these numbers and not to the numbers preceding the paragraphs.)

(NOTE.—Company drills naturally become monotonous. The monotony, however, can be greatly reduced by repeating the drills under varying circumstances. In the manual of arms, for instance, the company may be brought to open ranks and the officers and sergeants directed to superintend the drill in the front and rear ranks. As the men make mistakes they are fallen out and drilled nearby by an officer or noncommissioned officer. Or, the company may be divided into squads, each squad leader drilling his squad, falling out the men as they make mistakes, the men thus fallen out reporting to a designated officer or noncommissioned officer for drill. The men who have drilled the longest in the different squads are then formed into one squad and drilled and fallen out in like manner. The variety thus introduced stimulates a spirit of interest and rivalry that robs the drill of much of its monotony.)

It is thought the instruction of a company in drill is best attained by placing special stress on squad drill. The noncommissioned officers should be thoroughly instructed, practically and theoretically, by one of the company officers and then be required to instruct their squads. The squads are then united and drilled in the school of the company.—Author.)

DEFINITIONS

24. Alignment: A straight line upon which several elements are formed, or are to be formed; or the dressing of several elements upon a straight line.

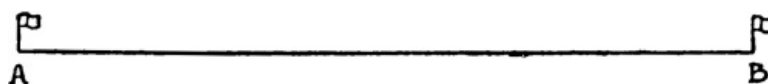

Fig. 1

NOTE.—The line A-B, on which a body of troops is formed or is to be formed, or the act of dressing a body of troops on the line, is called an alignment.—Author.

25. Base: The element on which a movement is regulated.

26. Battle sight: The position of the rear sight when the leaf is laid down.

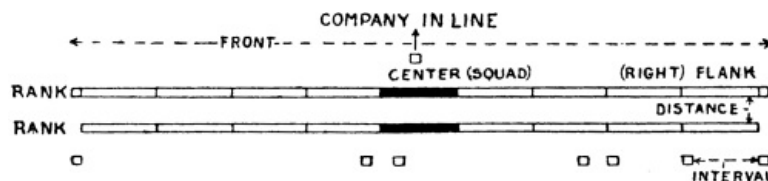

Fig. 2



Fig. 3

27. Center: The middle point or element of a command. (See [Figs. 2, 3](#) and [5](#).) (The designation "center company," indicates the right center or the actual center company, according as the number of companies is even or odd.—[Par. 298](#).)

28. Column: A formation in which the elements are placed one behind another. (See [Figs. 4, 5, 6](#).)

[Pg 21]

29. Deploy: To extend the front. In general to change from column to line, or from close order to extended order.

30. Depth: The space from head to rear of any formation, including the leading and rear elements. The depth of a man is assumed to be 12 inches. (See [Figs. 4, 5, 6](#).)

31. Distance: Space between elements in the direction of depth. Distance is measured from the back of the man in front to the breast of the man in rear. The distance between ranks is 40 inches in both line and column. (See [Figs. 4, 5, 6](#).)

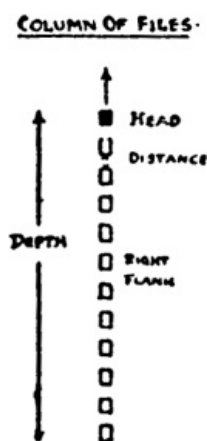

Fig. 4

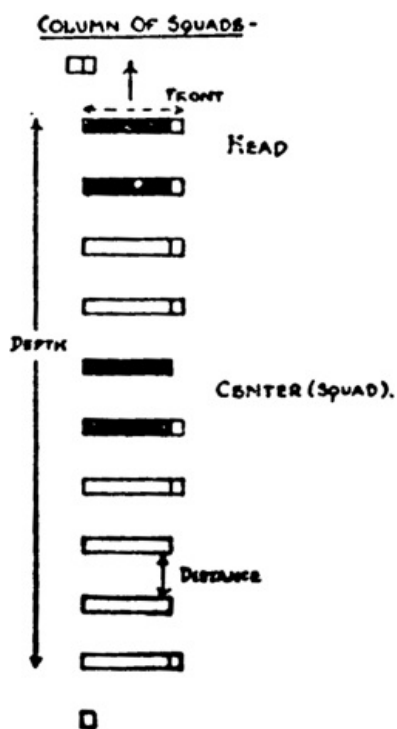

Fig. 5

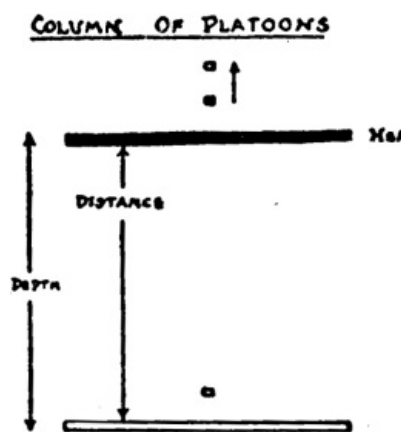

Fig. 6

32. Element: A file, squad, platoon, company, or larger body, forming part of a still larger body.

33. File: Two men, the front-rank man and the corresponding man of the rear rank. The front-rank man is the file leader. A file which has no rear-rank man is a blank file. The term file applies

also to a single man in a single-rank formation.

34. File closers: Such officers and noncommissioned officers of a company as are posted in rear of the line. For convenience, all men posted in the line of file closers.

35. Flank: The right or left of a command in line or in column; also the element on the right or left of the line. (See [Figs. 2, 3](#) and [4.](#))

36. Formation: Arrangement of the elements of a command. The placing of all fractions in their order in line, in column, or for battle.

37. Front: The space, in width, occupied by an element, either in line or in column. The front of a man is assumed to be 22 inches. Front also denotes the direction of the enemy. (See [Figs. 2, 3](#) and [5](#)).

38. Guide: An officer, noncommissioned officer, or private upon whom the command or elements thereof regulates its march.

39. Head: The leading element of a column. (See [Figs. 4, 5](#) and [6.](#))

40. Interval: Space between elements of the same line. The interval between men in ranks is 4 inches and is measured from elbow to elbow. Between companies, squads, etc., it is measured from the left elbow of the left man or guide of the group on the right, to the right elbow of the right man or guide of the group on the left. (See [Fig. 3.](#))

[Pg 22]

41. Left: The left extremity or element of a body of troops.

42. Line: A formation in which the different elements are abreast of each other. (See [Figs. 2](#) and [3.](#))

43. Order, close: The formation in which the units, in double rank, are arranged in line or in column with normal intervals and distances.

44. Order, extended: The formation in which the units are separated by intervals greater than in close order.

45. Pace: Thirty inches; the length of the full step in quick time.

46. Point of rest: The point at which a formation begins. Specifically, the point toward which units are aligned in successive movements.

47. Rank: A line of men placed side by side.

48. Right: The right extremity or element of a body of troops.

49. NOTE. In view of the fact that the word "Echelon" is a term of such common usage, the following definition is given: By echelon we mean a formation in which the subdivisions are placed one behind another, extending beyond and unmasking one another either wholly or in part.—Author.

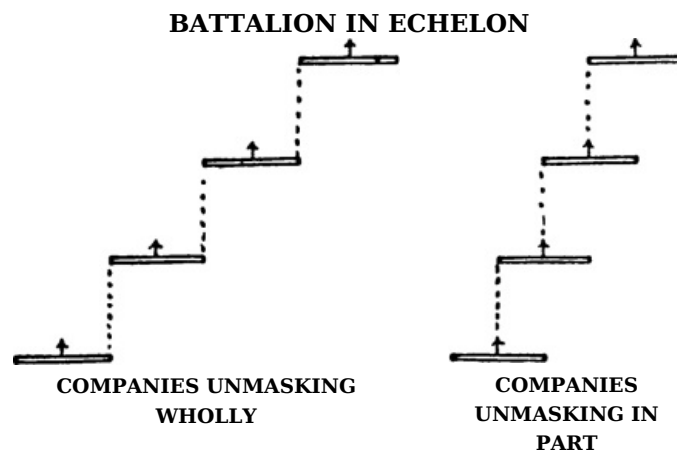

INTRODUCTION

50. Object of military training. Success in battle is the ultimate object of all military training; success may be looked for only when the training is intelligent and thorough. (1)

51. Commanding officers accountable for proper training of organizations; field efficiency; team-work. Commanding officers are accountable for the proper training of their respective organizations within the limits prescribed by regulations and orders. (2)

The excellence of an organization is judged by its field efficiency. The field efficiency of an

organization depends primarily upon its effectiveness as a whole. Thoroughness and uniformity in the training of the units of an organization are indispensable to the efficiency of the whole; it is by such means alone that the requisite team-work may be developed.

52. Simple movements and elastic formations. Simple movements and elastic formations are essential to correct training for battle. (3)

[Pg 23]

53. Drill Regulations a Guide; their interpretation. The Drill Regulations are furnished as a guide. They provide the principles for training and for increasing the probability of success in battle. (4)

In the interpretation of the regulations, the spirit must be sought. Quibbling over the minutiae of form is indicative of failure to grasp the spirit.

54. Combat principles. The principles of combat are considered in Pars. 50-363. They are treated in the various schools included in Part I of the Drill Regulations only to the extent necessary to indicate the functions of the various commanders and the division of responsibility between them. The amplification necessary to a proper understanding of their application is to be sought in Pars. 364-613. (5)

55. Drills at attention, ceremonies, extended order, field exercises and combat exercises. The following important distinctions must be observed:

(a) Drills executed at **attention** and the ceremonies are **disciplinary exercises** designed to teach precise and soldierly movement, and to inculcate that prompt and subconscious obedience which is essential to proper military control. To this end, smartness and precision should be exacted in the execution of every detail. Such drills should be frequent, but short.

(b) The purpose of **extended order drill** is to teach the **mechanism** of deployment of the firing, and, in general, of the employment of troops in combat. Such drills are in the nature of disciplinary exercises and should be frequent, thorough, and exact, in order to habituate men to the firm control of their leaders. Extended order drill is executed **at ease**. The company is the largest unit which executes extended order drill.

(c) **Field exercises** are for instruction in the duties incident to campaign. Assumed situations are employed. Each exercise should conclude with a discussion, on the ground, of the exercise and principles involved.

(d) The **combat exercise, a form of field exercise** of the company, battalion, and larger units, consists of the **application of tactical principles** to assumed situations, employing in the execution the appropriate formations and movements of close and extended order.

Combat exercises must simulate, as far as possible, the battle conditions assumed. In order to familiarize both officers and men with such conditions, companies and battalions will frequently be consolidated to provide war-strength organizations. Officers and noncommissioned officers not required to complete the full quota of the units participating are assigned as observers or umpires.

The firing line can rarely be controlled by the voice alone; thorough training to insure the proper use of prescribed signals is necessary.

The exercise should be followed by a brief drill at attention in order to restore smartness and control. (6)

56. Imaginary, outlined and represented enemy. In field exercises the enemy is said to be **imaginary** when his position and force are merely assumed; **outlined** when his position and force are indicated by a few men; **represented** when a body of troops acts as such. (7)

[Pg 24]

General Rules for Drills and Formations

57. Arrangement of elements of preparatory command. When the **preparatory** command consists of more than one part, its elements are arranged as follows:

(1) For movements to be executed successively by the subdivisions or elements of an organization: (a) Description of the movement; (b) how executed, or on what element executed.

(For example: **1. Column of Companies, first company, squads right. 2. March.**—Author.)

(2) For movements to be executed simultaneously by the subdivisions of an organization: (a) The designation of the subdivisions; (b) The movement to be executed. (For example: **1. Squads right. 2. March.**—Author.) (8)

58. Movements executed toward either flank explained toward but one flank. Movements that may be executed toward either flank are explained as toward but one flank, it being necessary to substitute the word "left" for "right," and the reverse, to have the explanation of the

corresponding movement toward the other flank. The commands are given for the execution of the movements toward either flank. The substitute word of the command is placed within parentheses. (9)

59. Any movement may be executed from halt or when marching unless otherwise prescribed. Any movement may be executed either from the halt or when marching, unless otherwise prescribed. If at a halt, the command for movements involving marching need not be prefaced by **forward**, as **1. Column right (left), 2. MARCH.** (10)

60. Any movement may be executed in double time unless specially excepted. Any movement not specially excepted may be executed in double time.

If at a halt, or if marching in quick time, the command **double time** precedes the command of execution. (11)

61. Successive movements executed in double time. In successive movements executed in double time the leading or **base** unit marches in **quick time** when not otherwise prescribed; the other units march in **double time** to their places in the formation ordered and then conform to the gait of the leading or base unit. If marching in double time, the command **double time** is omitted. The leading or base unit marches in **quick time**; the other units continue at double time to their places in the formation ordered and then conform to the gait of the leading or base unit. (12)

62. To hasten execution of movement begun in quick time. To hasten the execution of a movement begun in quick time, the command: **1. Double time, 2. MARCH,** is given. The leading or base unit continues to march in quick time, or remains at halt, if already halted; the other units complete the execution of the movement in double time and then conform to the gait of the leading or base unit. (13)

63. To stay execution of movement when marching, for correction of errors. To stay the execution of a movement when marching, for the correction of errors, the command: **1. In place, 2. HALT,** is given. All halt and stand fast without changing the position of the pieces. To resume the movement the command: **1. Resume, 2. MARCH,** is given. (14)

[Pg 25]

64. To revoke preparatory command or begin anew movement improperly begun. To revoke a preparatory command, or, being at a halt, to begin anew a movement improperly begun, the command, **AS YOU WERE,** is given, at which the movement ceases and the former position is resumed. (15)

65. Guide. Unless otherwise announced, the guide of a company or subdivision of a company in line is **right**; of a battalion in line or line of subdivisions or of a deployed line, **center**; of a rank in column of squads, toward the side of the guide of the company.

To march with guide other than as prescribed above, or to change the guide: **Guide (right, left, or center).**

In successive formations into line, the guide is toward the point of rest; in platoons or larger subdivisions it is so announced.

The announcement of the guide, when given in connection with a movement follows the command of execution for that. Exception: **1. As skirmishers, guide right (left or center), 2. MARCH.** (16)

66. Turn on fixed and moving pivots. The turn on the fixed pivot by subdivisions is used in all formations from line into column and the reverse.

The turn on the **moving pivot** is used by subdivisions of a column in executing changes of direction. (17)

67. Partial changes of direction. Partial changes of direction may be executed:

By interpolating in the preparatory command the word **half**, as **Column half right (left), or Right (left) half turn.** A change of direction of 45° is executed.

By the command: **INCLINE TO THE RIGHT (LEFT).** The guide, or guiding element, moves in the indicated direction and the remainder of the command conforms. This movement effects slight changes of direction. (18)

68. Line of platoons, companies, etc. The **designations line of platoons, line of companies, line of battalions,** etc., refer to the formations in which the platoons, companies, battalions, etc., each in column of squads, are in line. (19)

69. Full distance in column of subdivisions; guide of leading subdivision charged with step and direction. Full distance in column of subdivisions is such that in forming line to the right or left the subdivisions will have their proper intervals.

In column of subdivisions the guide of the leading subdivision is charged with the step and direction; the guides in rear preserve the trace, step, and distance. (20)

70. Double rank, habitual close order formation; uniformity of interval between files obtained by placing hand on hip. In close order, all details, detachments, and other bodies of troops are habitually formed in double rank.

To insure uniformity of interval between files when falling in, and in alignments, each man places the palm of the left hand upon the hip, fingers pointing downward. In the first case, the hand is dropped by the side when the next man on the left has his interval; in the second case, at the command front. (21)

[Pg 26]

71. Posts of officers, noncommissioned officers, and special units; duties of file closers. The posts of officers, noncommissioned officers, special units (such as band or machine-gun company), etc., in the various formations of the company, battalion, or regiment, are shown in plates.

In all changes from one formation to another involving a change of post on the part of any of these, posts are promptly taken by the most convenient route as soon as practicable after the command of execution for the movement; officers and noncommissioned officers who have prescribed duties in connection with the movement ordered, take their new posts when such duties are completed.

As instructors, officers and noncommissioned officers go wherever their presence is necessary. As file closers it is their duty to rectify mistakes and insure steadiness and promptness in the ranks. (22)

72. Special units have no fixed posts except at ceremonies.

Except at ceremonies, the special units have no fixed places. They take places as directed; in the absence of directions, they conform as nearly as practicable to the plates, and in subsequent movements maintain their relative positions with respect to the flank or end of the command on which they were originally posted. (23)

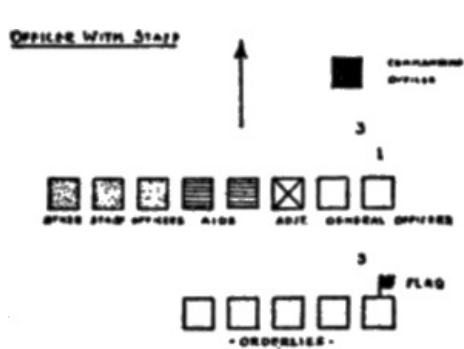

73. General, field and staff officers habitually mounted; formation of staff; drawing and returning saber. General, field, and staff officers are habitually mounted. The staff of any officer forms in single rank, 3 paces in rear of him, the right of the rank extending 1 pace to the right of a point directly in rear of him. Members of the staff are arranged in order from right to left as follows: General staff officers, adjutant, aids, other staff officers, arranged in each classification in order of rank, the senior on the right. The flag of the general officer and the orderlies are 3 paces in rear of the staff, the flag on the right. When necessary to reduce the front of the staff and orderlies, each line executes **twos right or**

fours right, as explained in the Cavalry Drill Regulations, and follows the commander.

When not otherwise prescribed, staff officers draw and return saber with their chief. (24)

74. Mounted officer turns to left in executing about; when commander faces about to give commands, staff and others stand fast. In making the about, an officer, mounted, habitually turns to the left.

When the commander faces to give commands, the staff, flag, and orderlies do not change position. (25)

75. Saluting when making and receiving reports; saluting on meeting. When making or receiving official reports, or on meeting out of doors, all officers will salute.

Military courtesy requires the junior to salute first, but when the salute is introductory to a report made at a military ceremony or formation, to the representative of a common superior (as, for example, to the adjutant, officer of the day, etc.), the officer making the report, whatever his rank, will salute first; the officer to whom the report is made will acknowledge by saluting that he has received and understood the report. (26)

[Pg 27]

76. Formation of mounted enlisted men for ceremonies. For ceremonies, all mounted enlisted men of a regiment or smaller unit, except those belonging to the machine-gun organizations, are consolidated into a detachment; the senior present commands if no officer is in charge. The detachment is formed as a platoon or squad of cavalry in line or column of fours; noncommissioned staff officers are on the right or in the leading ranks. (27)

77. Post of dismounted noncommissioned staff officers for ceremonies. For ceremonies, such of the noncommissioned staff officers as are dismounted are formed 5 paces in rear of the color, in order of rank from right to left. In column of squads they march as file closers. (28)

78. Post of noncommissioned staff officers and orderlies other than for ceremonies. Other than for ceremonies, noncommissioned staff officers and orderlies accompany their immediate chiefs unless otherwise directed. If mounted, the noncommissioned staff officers are ordinarily posted on the right or at the head of the orderlies. (29)

79. Noncommissioned officer commanding platoon or company, carrying of piece and taking of post. In all formations and movements a noncommissioned officer commanding a platoon or company carries his piece as the men do, if he is so armed, and takes the same post as an officer in like situation. When the command is formed in line for ceremonies, a noncommissioned officer commanding a company takes post on the right of the right guide after the company has been aligned. (30)

ORDERS, COMMANDS, AND SIGNALS

80. When commands, signals, and orders are used. Commands only are employed in drill at attention. Otherwise either a **command, signal, or order** is employed, as best suits the occasion, or one may be used in conjunction with another. (31)

81. Instruction in use of signals; use of headdress, etc., in making signals. Signals should be freely used in instruction, in order that officers and men may readily know them. In making arm signals, the saber, rifle, or headdress may be held in the hand. (32)

82. Fixing of attention; a signal includes command of preparation and of execution. Officers and men fix their attention at the first word of command, the first note of the bugle or whistle, or the first motion of the signal. A signal includes both the preparatory command and the command of execution; the movement commences as soon as the signal is understood, unless otherwise prescribed. (33)

83. Repeating orders, commands and signals; officers, platoon leaders, guides and musicians equipped with whistles; whistles with different tones. Except in movements executed at **attention**, commanders or leaders of subdivisions repeat orders, commands, or signals whenever such repetition is deemed necessary to insure **prompt** and correct execution.

Officers, battalion noncommissioned staff officers, platoon leaders, guides, and musicians are equipped with whistles. [Pg 28]

The Major and his staff will use a whistle of distinctive tone; the captain and company musicians a second and distinctive whistle; the platoon leaders and guides a third distinctive whistle. (34)

84. Limitation of prescribed signals; special prearranged signals. Prescribed signals are limited to such as are essential as a substitute for the voice under conditions which render the voice inadequate.

Before or during an engagement special signals may be agreed upon to facilitate the solution of such special difficulties as the particular situation is likely to develop, but it must be remembered that simplicity and certainty are indispensable qualities of a signal. (35)

Orders

85. Orders defined; when employed. In these regulations an **order** embraces instructions or directions given orally or in writing in terms suited to the particular occasion and not prescribed herein.

Orders are employed only when the **commands** prescribed herein do not sufficiently indicate the will of the commander.

Orders are more fully described in [paragraphs 378](#) to 383, inclusive. (36)

Commands

86. Command defined. In these regulations a **command** is the will of the commander expressed in the phraseology prescribed herein. (37)

87. Kinds of commands; how given. There are two kinds of commands:

The **preparatory** command, such as **forward**, indicates the movement that is to be executed.

The command of **execution**, such as **MARCH, HALT, or ARMS**, causes the execution.

Preparatory commands are distinguished by **italics**; those of execution by **CAPITALS**.

Where it is not mentioned in the text who gives the commands prescribed, they are to be given by the commander of the unit concerned.

The **preparatory** command should be given at such an interval of time before the command of **execution** as to admit of being properly understood; the command of **execution** should be given at the instant the movement is to commence.

The tone of command is animated, distinct, and of a loudness proportioned to the number of men for whom it is intended.

Each **preparatory** command is enunciated distinctly, with a rising inflection at the end, and in such manner that the command of **execution** may be more energetic.

The command of **execution** is firm in tone and brief. (38)

88. Battalion and higher commanders repeat commands of superiors; battalion largest unit executing movement at command of its commander. Majors and commanders of units larger than a battalion repeat such commands of their superiors as are to be executed by their units, facing their units for that purpose. The battalion is the largest unit that executes a movement at the command of execution of its commander. (39)

[Pg 29]

89. Facing troops and avoiding indifference when giving commands. When giving commands to troops it is usually best to face toward them.

Indifference in giving commands must be avoided as it leads to laxity in execution. Commands should be given with spirit at all times. (40)

Bugle Signals

90. Bugle signals that may be used on and off the field of battle. The authorized bugle signals are published in Part V of these regulations.

The following bugle signals may be used off the battlefield, when not likely to convey information to the enemy:

- Attention:** Troops are brought to attention.
- Attention to orders:** Troops to fix their attention.
- Forward, march:** Used also to execute quick time from double time.
- Double time, march.**
- To the rear, march:** In close order, execute **squads right about.**
- Halt.**
- Assemble, march.**

The following bugle signals may be used on the battlefield:

- Fix bayonets.**
- Charge.**
- Assemble, march.**

These signals are used only when intended for the entire firing line; hence they can be authorized only by the commander of a unit (for example, a regiment or brigade) which occupies a distinct section of the battlefield. Exception: **Fix bayonet.** (See [par. 355.](#))

The following bugle signals are used in exceptional cases on the battlefield. Their principal uses are in field exercises and practice firing.

Commence firing: Officers charged with fire direction and control open fire as soon as practicable. When given to a firing line, the signal is equivalent to **fire at will.**

Cease firing: All parts of the line execute **cease firing** at once.

These signals are not used by units smaller than a regiment, except when such unit is independent or detached from its regiment. (41)

Whistle Signals

91. Attention to orders. A **short blast** of the whistle. This signal is used on the march or in combat when necessary to fix the attention of troops, or of their commanders or leaders, preparatory to giving commands, orders, or signals.

When the firing line is firing, each squad leader suspends firing and fixes his attention at a **short blast** of his platoon leader's whistle. The platoon leader's subsequent commands or signals are repeated and enforced by the squad leader. If a squad leader's attention is attracted by a whistle other than that of his platoon leader, or if there are no orders or commands to convey to his squad, he resumes firing at once.

Suspend firing. A **long blast** of the whistle. All other whistle signals are prohibited. (42)

92. The following arm signals are prescribed. In making signals either arm may be used. Officers who receive signals on the firing line "repeat back" at once to prevent misunderstanding.



FORWARD

Forward, MARCH. Carry the hand to the shoulder; straighten and hold the arm horizontally, thrusting it in the direction of march.

This signal is also used to execute quick time from double time.



HALT—ARM
HELD
STATIONARY

Halt. Carry the hand to the shoulder; thrust the hand upward and hold the arm vertically.

Double time, MARCH. Carry the hand to the shoulder; rapidly thrust the hand upward the full extent of the arm several times.

DOUBLE TIME—
ARM MOVED UP
AND DOWN
SEVERAL TIMES



SQUADS RIGHT

Squads right, MARCH. Raise the arm laterally until horizontal; carry it to a vertical position above the head and swing it several times between the vertical and horizontal positions.



SQUADS LEFT

Squads left, MARCH. Raise the arm laterally until horizontal; carry it downward to the side and swing it several times between the downward and horizontal positions.



SQUADS RIGHT
ABOUT

Squads right about, MARCH (if in close order) or, **To the rear, MARCH** (if in skirmish line). Extend the arm vertically above the head; carry it laterally downward to the side and swing it several times between the vertical and downward positions.

TO THE REAR



CHANGE
DIRECTION

Change direction or Column right (left), MARCH. The hand on the side toward which the change of direction is to be made is carried across the body to the opposite shoulder, forearm horizontal; then swing in a horizontal plane, arm extended, pointing in the new direction.



As skirmishers, MARCH. Raise both arms laterally until horizontal.

As SKIRMISHERS



As skirmishers, guide center, MARCH. Raise both arms laterally until horizontal; swing both simultaneously upward until vertical and return to the horizontal; repeat several times.

**As
SKIRMISHERS,
GUIDE CENTER**



As skirmishers, guide right (left), MARCH. Raise both arms laterally until horizontal; hold the arm on the side of the guide steadily in the horizontal position; swing the other upward until vertical and return it to the horizontal; repeat several times.

[Pg 32]

**As
SKIRMISHERS,
GUIDE RIGHT**



Assemble, March. Raise the arm vertically to full extent and describe horizontal circles.

ASSEMBLE

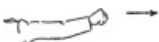

Range or Change elevation. To announce range, extend the arm toward the leaders or men for whom the signal is intended, fist closed; by keeping the fist closed battle sight is indicated;

**To ANNOUNCE
RANGE—BATTLE
SIGHT**



by opening and closing the fist, expose thumb and fingers to a number equal to the hundreds of yards;

**RANGE 300—
OR INCREASE
By 300**



to add yards describe a short horizontal line with forefinger.

**ADD 50 YARDS
(TOP VIEW)**



To change elevation, indicate the **amount of increase or decrease** by fingers as above; point upward to indicate increase and downward to indicate decrease.

**DECREASE BY
300**



WHAT RANGE
ARE YOU
USING?

What range are you using? or **What is the range?** Extend the arms toward the person addressed, one hand open, palm to the front, resting on the other hand, fist closed.



ARE YOU
READY?

Are you ready? or **I am ready.** Raise the hand, fingers extended and joined, palm toward the person addressed.



COMMENCE
FIRING

Commence firing. Move the arm extended in full length, hand palm down, several times through a horizontal arc in front of the body.

Fire faster. Execute rapidly the signal, "Commence Firing."

Fire slower. Execute slowly the signal, "Commence Firing."



SWING THE
CONE OF FIRE
TO THE RIGHT

Swing the cone of fire to the right, or left. Extend the arm in full length to the front, palm to the right (left); swing the arm to right (left), and point in the direction of the new target.



Fix Bayonet. Simulate the movement of the right hand in "Fix bayonet." (See [par. 142.](#))



SUSPEND FIRING

Suspend firing. Raise and hold the forearm steadily in a horizontal position in front of the forehead, palm of the hand to the front.

Cease firing. Raise the forearm as in **suspend firing** and swing it up and down several times in front of the face.

CEASE FIRING—
SWING ARM UP
AND DOWN
SEVERAL TIMES



PLATOON

Platoon. Extend the arm horizontally toward the platoon leader; describe small circles with the hand. (See [par. 93.](#))

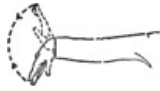

SQUAD

Squad. Extend the arm horizontally toward the platoon leader; swing the hand up and down from the wrist. (See [par. 93.](#))

Rush. Same as **double time.** (43)

93. Use of signals "platoon" and "squad." The signals **platoon** and **squad** are intended primarily for communication between the captain and his platoon leaders. The signal platoon or squad indicates that the platoon commander is to cause the signal which follows to be executed by platoon or squad.

Note.—The following signals, while not prescribed, are very convenient:

Combined Sights. Extend the arm toward the leaders for whom the signal is intended, hand open and turn hand rapidly from right to left a number of times. Then indicate ranges in the manner prescribed, giving the mean of the two ranges. (For example: If the combined sights are 1050 and 1150, indicate a range of 1100 yards. The leaders who give the oral commands, give the command, "Range 1050 and 1150," whereupon every man in the front rank, before deployment, fixes his sight at 1150, and every man in the rear rank, before deployment, fixes his sight at 1050.)

Company. Bring the hand up near the shoulder and then thrust to the front, snapping fingers in usual way; repeat several times.

Contract fire. Extend both arms horizontally, fingers extended, arms parallel, palms facing each other; bring hands together **once**, and hold them so and look at the leader concerned.

Disperse fire. Bring hands together, fingers extended, pointing in direction of leader concerned, arms extended horizontally; swing arms outward once, and hold them so and look at the leader concerned.

Platoon column. Raise both arms vertically, full length, arms parallel, fingers joined and extended, palms to the front.

Prepare to rush. Cross the arms horizontally several times.

[Pg 35]

Squad Column. Raise both arms vertically from elbows, elbows at side of body, fingers joined and extended, palms to the front.—Author. (44)

Flag Signals

94. Signal flags carried by company musicians; description of flags. The signal Hags described below are carried by the company musicians in the field.

In a regiment in which it is impracticable to make the permanent battalion division alphabetically, the flags of a battalion are as shown; flags are assigned to the companies alphabetically, within their respective battalions, in the order given below.

First battalion:

- Company A. Red field, white square.
- Company B. Red field, blue square.
- Company C. Red field, white diagonals.
- Company D. Red field, blue diagonals.

Second battalion:

- Company E. White field, red square.
- Company F. White field, blue square.
- Company G. White field, red diagonals.
- Company H. White field, blue diagonals.

Third battalion:

- Company I. Blue field, red square.
- Company K. Blue field, white square.
- Company L. Blue field, red diagonals.
- Company M. Blue field, white diagonals.

Note.—An analysis of the above system of signal flags will show: 1. The color of the field indicates the battalion and the colors run in the order that is so natural to us all, viz: **Red**, **White** and **Blue**. Hence **red** field indicates the **first** battalion; **white** field, the **second**; **blue** field, the **third**.

2. The **squares** indicate the first two companies of each battalion, and the **diagonals**, the second two. Hence,

Companies			Indicated by
A	E	I	Squares
B	F	K	
C	G	L	Diagonals
D	H	M	

3. The colors of the squares and diagonals in combination with those of the fields, run in the order that is so natural to us all, viz.: **Red, White** and **Blue**, the color of any given field being, of course, omitted from the squares and diagonals, as a white square for instance, would not show on a white field, nor would a blue diagonal show on a blue field. For example, with a **red** field we would have **white** and **blue** for the square and diagonal colors; with a **white** field, **red** and **blue** for the square and diagonal colors; with a **blue** field, **red** and **white** for the square and diagonal colors.

[Pg 36]

4. From what has been said, the following table explains itself:

Battalion	Field	Co.	Squares	Diagonals
First	Red	A	White	White Blue
		B	Blue	
		C		
		D		
Second	White	E	Red	Red Blue
		F	Blue	
		G		
		H		
Third	Blue	I	Red	Red White
		K	White	
		L		
		M		

Note how the square and diagonal colors always follow in the natural order of **red, white, and blue**, with the color of the field omitted.—Author. (45)

95. Signal flags used to mark assembly point of company, etc. In addition to their use in visual signaling, these flags serve to mark the assembly point of the company when disorganized by combat, and to mark the location of the company in bivouac and elsewhere, when such use is desirable. (46)

96. Signals used between firing line and reserve or commander in rear. (1) For communication between the firing line and the reserve or commander in the rear, the subjoined signals (Signal Corps codes) are prescribed and should be memorized. In transmission, their concealment from the enemy's view should be insured. In the absence of signal flags, the headdress or other substitute may be used. (See [par. 863](#) for the semaphore code and [par. 861](#) for the General Service, or International Morse Code.) (47)

Letter of alphabet	If signaled from the rear to the firing line	If signaled from the firing line to the rear
A M	Ammunition going forward.	Ammunition required.
C C C	Charge (mandatory at all times).	Am about to charge if no instructions to the contrary.
C F	Cease firing.	Cease firing.
D T	Double time or "rush."	Double time or "rush."
F	Commence firing.	Commence firing.
F B	Fix bayonets.	Fix bayonets.
F L	Artillery fire is causing us losses.	Artillery fire is causing us losses.
G	Move forward.	Preparing to move forward.
H H H	Halt.	Halt.
K	Negative.	Negative.
L T	Left.	Left.
O		
(Ardois and semaphore only.)	What is the (R. N. etc.)? Interrogatory.	What is the (R. N. etc.)? Interrogatory.
(All methods but ardois and semaphore.)	What is the (R. N. etc.)? Interrogatory.	What is the (R. N. etc.)? Interrogatory.
P	Affirmative.	Affirmative.
R	Acknowledgment.	Acknowledgment.
R N	Range.	Range.
R T	Right.	Right.
S S S	Support going forward.	Support needed.
S U F	Suspend firing.	Suspend firing.

[Pg 37]

For the semaphore signals, see [par. 863](#).

SCHOOL OF THE SOLDIER

97. Duties of instructor. The instructor explains briefly each movement, first executing it himself if practicable. He requires the recruits to take the proper positions unassisted and does not touch them for the purpose of correcting them, except when they are unable to correct themselves. He avoids keeping them too long at the same movement, although each should be understood before passing to another. He exacts by degrees the desired precision and uniformity. (48)

98. Grouping of recruits according to proficiency. In order that all may advance as rapidly as their abilities permit, the recruits are grouped according to proficiency as instruction progresses. Those who lack aptitude and quickness are separated from the others and placed under experienced drill masters. (49)

[Pg 38]

Instruction Without Arms

98a. Formation of squad for preliminary instruction. For preliminary instruction a number of recruits, usually not exceeding three or four, are formed as a squad in single rank. (50)

Position of the Soldier, or Attention

99. Heels on the same line and as near each other as the conformation of the man permits.

Feet turned out equally and forming an angle of about 45°.

Knees straight without stiffness.

Hips level and drawn back slightly; body erect and resting equally on hips; chest lifted and arched; shoulders square and falling equally.

Arms and hands hanging naturally, thumb along the seam of the trousers.

Head erect and squarely to the front, chin drawn in so that the axis of the head and neck is vertical; eyes straight to the front.

Weight of the body resting equally upon the heels and balls of the feet. (51)

The Rests

100. Being at a halt, the commands are: **FALL OUT; REST; AT EASE;** and, **1. Parade, 2. REST.**

At the command **fall out**, the men may leave the ranks, but are required to remain in the immediate vicinity. They resume their former places, at attention, at the command **fall in**.

At the command **rest** each man keeps one foot in place, but is not required to preserve silence or immobility.

At the command **at ease** each man keeps one foot in place and is required to preserve silence but **not** immobility. (52)



101. 1. Parade, 2. REST. Carry the right foot 6 inches straight to the rear, left knee slightly bent; clasp the hands, without constraint, in front of the center of the body, fingers joined, left hand uppermost, left thumb clasped by the thumb and forefinger of the right hand; preserve silence and steadiness of position. (53)

102. To resume the attention: **1. Squad, 2. ATTENTION.**

The men take the position of the soldier. (54)

[Pg 39]

Eyes Right or Left

103. 1. Eyes, 2. RIGHT (LEFT), 3. FRONT.



At the command **right**, turn the head to the right oblique, eyes fixed on the line of eyes of the men in, or supposed to be in, the same rank. At the command **front**, turn the head and eyes to the front. (55)

Facings

104. To the flank: 1. Right (left), 2. FACE.

Raise slightly the left heel and right toe; face to the right, turning on the right heel, assisted by a slight pressure on the ball of the left foot; place the left foot by the side of the right. Left face is executed on the left heel in the corresponding manner.

Right (left) half face is executed similarly, facing 45°.

"To face in marching" and advance, turn on the ball of either foot and step off with the other foot in the new line of direction; to face in marching without gaining ground in the new direction, turn on the ball of either foot and mark time. (56)

105. To the rear: 1. About, 2. FACE.

Carry the toe of the right foot about a half foot-length to the rear and slightly to the left of the left heel without changing the position of the left foot; face to the rear, turning to the right on the left heel and right toe; place the right heel by the side of the left. (57)

Salute with the Hand

106. 1. Hand, 2. SALUTE.



Raise the right hand smartly till the tip of the forefinger touches the lower part of the headdress or forehead above the right eye, thumb and fingers extended and joined palm to the left, forearm inclined at about 45°, hand and wrist straight; **at the same time look toward the person saluted.** (TWO) Drop the arm smartly by the side. (58)

(For rules governing salutes, see "Military Courtesy," Chapter XI, Part II.)

[Pg 40]

Steps and Marchings

107. Steps and marchings begin with left foot. All steps and marchings executed from a halt, except right step, begin with the left foot. (59)

108. Length and cadence of full step; indicating cadence. The length of the full step in quick time is 30 inches, measured from heel to heel, and the cadence is at the rate of 120 steps per minute.

The length of the full step in double time is 36 inches; the cadence is at the rate of 180 steps per minute.

The instructor, when necessary, indicates the cadence of the step by calling **one, two, three, four**, or **left, right**, the instant the left and right foot, respectively, should be planted. (60)

109. Steps and marchings and movements involving marchings habitually executed in

quick time. All steps and marchings and movements involving march are executed in **quick time** unless the squad be marching in **double time**, or **double time** be added to the command; in the latter case double time is added to the preparatory command. Example: **1. Squad right, double time, 2. MARCH** (School of the Squad). (61)

Quick Time

110. Being at a halt, to march forward in quick time: **1. Forward, 2. MARCH.**

At the command **forward**, shift the weight of the body to the right leg, left knee straight.

At the command **march**, move the left foot smartly straight forward 30 inches from the right, sole near the ground, and plant it without shock; next in like manner, advance the right foot and plant it as above; continue the march. The arms swing naturally. (62)

111. Being at a halt, or in march in quick time, to march in double time: **1. Double time, 2. MARCH.**

If at a halt, at the first command shift the weight of the body to the right leg. At the command **march**, raise the forearms, fingers closed, to a horizontal position along the waist line; take up an easy run with the step and cadence of double time, allowing a natural swinging motion to the arms.

If marching in quick time, at the command **march**, given as either foot strikes the ground, take one step in quick time, and then step off in double time. (63)

To resume the quick time: **1. Quick time, 2. MARCH.**

At the command **march**, given as either foot strikes the ground, advance and plant the other foot in double time; resume the quick time, dropping the hands by the sides. (64)

To Mark Time

112. Being in march: **1. Mark time, 2. MARCH.**

At the command **march**, given as either foot strikes the ground, advance and plant the other foot; bring up the foot in rear and continue the cadence by alternately raising each foot about 2 inches and planting it on line with the other.

Being at a halt, at the command **march**, raise and plant the feet as described above. (65)

[Pg 41]

The Half Step

113. 1. Half step, 2. MARCH.

Take steps of 15 inches in quick time, 18 inches in double time. (66)

Forward, half step, halt, and **mark time** may be executed one from the other in quick or double time.

To resume the full step from half step or mark time: **1. Forward, 2. MARCH.** (67)

Side Step

114. Being at a halt or mark time: **1. Right (left) step, 2. MARCH.**

Carry and plant the right foot 15 inches to the right; bring the left foot beside it and continue the movement in the cadence of quick time.

The side step is used for short distances only and is not executed in double time.

If at order arms, the side step is executed at trail without command. (68)

Back Step

115. Being at a halt or mark time: **1. Backward, 2. MARCH.**

Take steps of 15 inches straight to the rear.

The back step is used for short distances only and is not executed in double time.

If at order arms, the back step is executed at trail without command. (69)

To Halt

116. To arrest the march in quick or double time: **1. Squad, 2. HALT.**

At the command **halt**, given as either foot strikes the ground, plant the other foot as in marching; raise and place the first foot by the side of the other. If in double time, drop the hands by the sides. (70)

To March by the Flank

117. Being in march: **1. By the right (left) flank, 2. MARCH.**

At the command **march**, given as the right foot strikes the ground, advance and plant the left foot; then face to the right in marching and step off in the new direction with the right foot. (71)

To March to the Rear

118. Being in march: **1. To the rear, 2. MARCH.**

At the command **march** given as the right foot strikes the ground advance and plant the left foot; turn to the right about on the balls of both feet and immediately step off with the left foot.

If marching in double time, turn to the right about, taking four steps in place, keeping the cadence, and then step off with the left foot. (72)

[Pg 42]

Change Step

119. Being in march: **1. Change step, 2. MARCH.**

At the command **march**, given as the right foot strikes the ground, advance and plant the left foot; plant the toe of the right foot near the heel of the left and step off with the left foot.

The change on the right foot is similarly executed, the command march being given as the left foot strikes the ground. (73)

MANUAL OF ARMS

120. Instruction of recruit in use of rifle, manual of arms, etc. As soon as practicable the recruit is taught the use, nomenclature, and care of his rifle. (See "The Care, Description, and Management of the Rifle," Chapter XIV, Part II.); when fair progress has been made in the instruction without arms, he is taught the manual of arms; instruction without arms and that with arms alternate. (74)

121. Rules governing carrying of piece. The following rules governing the carrying of the piece:

First. **Piece habitually carried without cartridges in chamber or magazine.** The piece is not carried with cartridges in either the chamber or the magazine except when specifically ordered. When so loaded, or supposed to be loaded, it is habitually carried locked; that is, with the **safety lock** turned to the "safe." At all other times it is carried unlocked, with the trigger pulled.

Second. **Inspection of pieces when troops are formed and when dismissed.** Whenever troops are formed under arms, pieces are immediately inspected at the commands: **1. Inspection, 2. ARMS, 3. Order (Right shoulder port), 4. ARMS**, which are executed as explained in [pars. 145-146](#).

A similar inspection is made immediately before dismissal.

If cartridges are found in the chamber or magazine they are removed and placed in the belt.

Third. **Cut-off habitually turned "off."** The cut-off is kept turned "off" except when cartridges

are actually used.

Fourth. **Bayonet habitually not carried fixed.** The bayonet is not fixed (See [par. 142](#)), except in bayonet exercise, on guard, or for combat.

Fifth. **"Fall in" executed at order; "attention" resumed at order.** Fall in is executed with the piece at the order arms. **Fall out, rest, and at ease** are executed as without arms, as explained in [par. 100](#). On resuming **attention** the position of order arms is taken.

Sixth. **If at order, pieces brought to right shoulder at command "march"; execution of movements at trail; piece brought to trail in certain movements executed from order.** If at the order, unless otherwise prescribed, the piece is brought to the right shoulder at the command march, the three motions corresponding with the first three steps. Movements may be executed at the trail by prefacing the preparatory command with the words **at trail**; as, **1. At trail, forward, 2. MARCH**; the trail is taken at the command **march**.

When the facings, alignments, open and close ranks, taking interval or distance, and assemblings are executed from the order, raise the piece to the trail while in motion and resume the order on halting.

Seventh. **Piece brought to order on halting.** The piece is brought to the order on halting. The execution of the order begins when the halt is completed.

[Pg 43]

Eighth. **Holding disengaged hand in double time.** A disengaged hand in double time is held as when without arms. (75)

122. Rules governing manual of arms. The following rules govern the execution of the manual of arms:

First. **Position of left hand at balance.** In all positions of the left hand at the balance (center of gravity, bayonet unfixed) the thumb clasps the piece; the sling is included in the grasp of the hand.

Second. **Positions of piece "diagonally across the body."** In all positions of the piece "diagonally across the body" the position of the piece, left arm and hand are the same as in port arms. (See [par. 125](#).)



Third. **Next to last motion in resuming order from any position; piece to strike ground gently.** In resuming the order from any position in the manual, the motion next to the last concludes with the butt of the piece about 3 inches from the ground, barrel to the rear, the left hand above and near the right, steadying the piece, fingers extended and joined, forearm and wrist straight and inclining downward, all fingers of the right hand grasping the piece. To complete the order, lower the piece gently to the ground with the right hand, drop the left quickly by the side, and take the position of order arms.

Allowing the piece to drop through the right hand to the ground, or other similar abuse of the rifle to produce effect in executing the manual is prohibited.

Fourth. **Cadence of motions; at first attention to be paid to details of motion.** The cadence of the motions is that of quick time; the recruits are first required to give their whole attention to the details of the motions, the cadence being gradually acquired as they become accustomed to handling their pieces. The instructor may require them to count aloud in cadence with the motions.

Fifth. **Execution of manual "by the numbers."** The manual is taught at a halt and the movements are for the purpose of instruction, divided into motions and executed in detail; in this case the command of **execution** determines the prompt execution of the first motion, and the commands, **two, three, four**, that of the other motions.

To execute the movements in detail, the instructor first cautions: **By the numbers**; all movements divided into motions are then executed as above explained until he cautions: **Without the numbers**; or commands movements other than those in the manual of arms.

Sixth. **Regular positions assumed without regard to previous positions; carrying rifle in any position.** Whenever circumstances require, the regular positions of the manual of arms and the firings may be ordered without regard to the previous position of the piece.

Under the exceptional conditions of weather or fatigue the rifle may be carried in any manner directed. (76)

[Pg 44]

123. Position of order arms standing: The butt rests evenly on the ground, barrel to the rear, toe of the butt on a line with toe of, and touching, the right shoe, arms and hands hanging naturally, right hand holding the piece between the thumb and fingers. (77)



124. Being at order arms: 1. Present, 2. ARMS.



With the right hand carry the piece in front of the center of the body, barrel to the rear and vertical, grasp it with the left hand at the balance, forearm horizontal and resting against the body. **(TWO)** Grasp the small of the stock with the right hand. (78)

125. Being at order arms: 1. Port, 2. ARMS.



With the right hand raise and throw the piece diagonally across the body, grasp it smartly with both hands; the right, palm down, at the small of the stock: the left, palm up, at the balance; barrel up, sloping to the left and crossing opposite the junction of the neck with the left shoulder; right forearm horizontal; left forearm resting against the body; the piece in a vertical plane parallel to the front. (79)

126. Being at present arms: 1. Port, 2. ARMS.

[Pg 45]

Carry the piece **diagonally across** the body and take the position of port arms. (80)

127. Being at port arms: 1. Present, 2. ARMS.

Carry the piece to a vertical position in front of the center of the body and take the position of present arms. (81)

128. Being at present or port arms: 1. Order, 2. ARMS.

Let go with the right hand; lower and carry the piece to the right with the left hand: regrasp it with the right hand just above the lower band; let go with the left hand, and take the next to the last position in coming to the order. **(TWO)** Complete the order. (82)

129. Being at order arms: 1. Right shoulder, 2. ARMS.



With the right hand raise and throw the piece diagonally across the body; carry the right hand quickly to the butt, embracing it, the heel between the first two fingers. **(TWO)** Without changing the grasp of the right hand, place the piece on the right shoulder, barrel up and inclined at an angle of about 45° from the horizontal, trigger guard in the hollow of the shoulder, right elbow near the side, the piece in a vertical plane perpendicular to the front; carry the left hand, thumb and fingers extended and joined, to the small of the stock, tip of the forefinger touching the cocking piece, wrist straight and elbow down. **(THREE)** Drop the left hand by the side. (83)

130. Being at right shoulder arms: 1. Order, 2. ARMS.

Press the butt down quickly and throw the piece diagonally across the body, the right hand retaining the grasp of the butt. **(TWO)**, **(THREE)** Execute order arms as described from port arms. (84)

131. Being at port arms: 1. Right shoulder, 2. ARMS.

Change the right hand to the butt. (**TWO**), (**THREE**) As in right shoulder arms from order arms. (85)

132. Being at right shoulder arms: 1. Port, 2. ARMS.

Press the butt down quickly and throw the piece diagonally across the body, the right hand retaining its grasp of the butt. (**TWO**) Change the right hand to the small of the stock. (86)

133. Being at right shoulder arms: 1. Present, 2. ARMS.

Execute port arms. (**THREE**) execute present arms. (87)

134. Being at present arms: 1. Right shoulder, 2. ARMS.

Execute port arms. (**TWO**), (**THREE**), (**FOUR**) Execute right shoulder arms as from port arms. (88)

135. Being at port arms: 1. Left shoulder, 2. ARMS.

[Pg 46]



Carry the piece with the right hand and place it on the left shoulder, barrel up, trigger guard in the hollow of the shoulder; at the same time grasp the butt with the left hand, heel between first and second fingers, thumb and fingers closed on the stock. (**TWO**) Drop the right hand by the side.

136. Being at left shoulder arms: 1. Port, 2. ARMS.

Grasp the piece with the right hand at the small of the stock. (**TWO**) Carry the piece to the right with the right hand, **regrasp** it with the left, and take the position of port arms.

Left shoulder arms may be ordered directly from the order, right shoulder or present, or the reverse. At the command **arms** execute port arms and continue in cadence to the position ordered. (89)

137. Being at order arms: 1. Parade, 2. REST.



Carry the right foot 6 inches straight to the rear, left knee slightly bent; carry the muzzle in front of the center of the body, barrel to the left; grasp the piece with the left hand just below the stacking swivel, and with the right hand below and against the left.

138. Being at parade rest: 1. Squad, 2. ATTENTION.

Resume the order, the left hand quitting the piece opposite the right hip. (90)

139. Being at order arms: 1. Trail, 2. ARMS.

[Pg 47]



Raise the piece, right arm slightly bent, and incline the muzzle forward so that the barrel makes an angle of about 30° with the vertical.

When it can be done without danger or inconvenience to others, the piece may be grasped at the balance and the muzzle lowered until the piece is horizontal; a similar position in the left hand may be used. (91)

140. Being at trail arms: 1. Order, 2. ARMS.

Lower the piece with the right hand and resume the order. (92)

Rifle Salute

141. Being at right shoulder arms: 1. Rifle, 2. SALUTE.



Carry the left hand smartly to the small of the stock, forearm horizontal, palm of hand down, thumb and fingers extended and joined, forefinger touching end of cocking piece; look toward the person saluted. (**TWO**) Drop left hand by the side; turn head and eyes to the front. (93)



Being at order or trail arms: **1. Rifle, 2. SALUTE.**

Carry the left hand smartly to the right side, palm of the hand down, thumb and fingers extended and joined, forefinger against piece near the muzzle; look toward the person saluted. (**TWO**) Drop the left hand by the side; turn the head and eyes to the front.

For rules governing salutes, see "Military Courtesy," Chapter XI, Part II.

[Pg 48]

The Bayonet

142. Being at order arms: **1. Fix, 2. BAYONET.**

If the bayonet scabbard is carried on the belt: Execute parade rest; grasp the bayonet with the right hand, back of hand toward the body; draw the bayonet from the scabbard and fix it on the barrel, glancing at the muzzle; resume the order.

If the bayonet is carried on the haversack: Draw the bayonet with the left hand and fix it in the most convenient manner. (95)

143. Being at our arms: **1. Unfix, 2. BAYONET.**

If the bayonet scabbard is carried on the belt: Execute parade rest; grasp the handle of the bayonet firmly with the right hand, pressing the spring with the forefinger of the right hand; raise the bayonet until the handle is about 12 inches above the muzzle of the piece; drop the point to the left, back of the hand toward the body, and, glancing at the scabbard, return the bayonet, the blade passing between the left arm and the body; regrasp the piece with the right hand and resume the order.

If the bayonet scabbard is carried on the haversack: Take the bayonet from the rifle with the left hand and return it to the scabbard in the most convenient manner.

If marching or lying down, the bayonet is fixed and unfix in the most expeditious and convenient manner and the piece returned to the original position.

Fix and **unfix** bayonet are executed with promptness and regularity but not in cadence. (For unfixing bayonet with Krag rifle, see [Par. 697.](#)) (96)

144. CHARGE BAYONET. Whether executed at halt or in motion, the bayonet is held toward the opponent as in the position of **guard** in the Manual for Bayonet Exercise.

Exercises for instruction in bayonet combat are prescribed in the Manual for Bayonet Exercise. (97)

The Inspection

145. Being at order arms: **1. Inspection, 2. ARMS.**

At the second command take the position of port arms. (**TWO**) Seize the bolt handle with the thumb and forefinger of the right hand, turn the handle up, draw the bolt back, and glance at the chamber. Having found the chamber empty, or having emptied it, raise the head and eyes to the front. (For inspection of arms with Krag rifle see [par. 698.](#)) (98)

146. Being at inspection arms: **1. Order (Right shoulder, port), 2. ARMS.**

At the preparatory command push the bolt forward, turn the handle down, pull the



trigger, and resume **port arms**. At the command **arms**, complete the movement ordered. (To execute with Krag rifle see [par. 699.](#)) (99)

To Dismiss the Squad

147. Being at halt: **1. Inspection, 2. ARMS, 3. Port, 4. ARMS, 5. DISMISSED.** (100)

SCHOOL OF THE SQUAD

148. Grouping into Squads. Soldiers are grouped into squads for purposes of instruction, discipline, control, and order. (101)

149. Composition of squad; object of squad movements. The squad proper consists of a corporal and seven privates.

The movements in the School of the Squad are designed to make the squad a fixed unit and to facilitate the control and movement of the company. If the number of men grouped is more than 3 and less than 12, they are formed as a squad of 4 files, the excess above 8 being posted as file closers. If the number grouped is greater than 11, 2 or more squads are formed and the group is termed a platoon.

For the instruction of recruits, these rules may be modified. (102)

150. Squad leader; his post. The corporal is the squad leader, and when absent is replaced by a designated private. If no private is designated, the senior in length of service acts as leader.

The corporal, when in ranks, is posted as the left man in the front rank of the squad.

When the corporal leaves the ranks to lead his squad, his rear rank man steps into the front rank, and the file remains blank until the corporal returns to his place in ranks, when his rear rank man steps back into the rear rank. (103)

151. Preservation of integrity of squads in battle. In battle officers and sergeants endeavor to preserve the integrity of squads; they designate new leaders to replace those disabled, organize new squads when necessary, and see that every man is placed in a squad.

Men are taught the necessity of remaining with the squad to which they belong and, in case it be broken up or they become separated therefrom, to attach themselves to the nearest squad and platoon leaders, whether these be of their own or of another organization. (104)

152. Certain movements executed by squad as in School of the Soldier. The squad executes the **halt** (See [par. 116](#)), **rests** (See [par. 100-101](#)), **facings** (See [pars. 104-105](#)), **steps and marchings** (See [pars. 107-119](#)), and the **manual of arms** (See [pars. 120-147](#)), as explained in the School of the Soldier. (105)

To Form the Squad

153. To form the squad the instructor places himself 3 paces in front of where the center is to be and commands: **FALL IN.**

The men assemble at attention, pieces at the order, and are arranged by the corporal in double rank, as nearly as practicable in order of height from right to left, each man dropping his left hand as soon as the man in his left has his interval. The rear rank forms with distance of 40 inches.

The instructor then commands: **COUNT OFF.**

At this command all except the right file execute eyes right, and beginning on the right, the men in each rank count **one, two, three, four**; each man turns his head and eyes to the front as he counts.

Pieces are then inspected. (106)

Alignments

154. To align the squad, the base file or files having been established: **1. Right (Left), 2. DRESS, 3. FRONT.**

At the command front, given when the ranks are aligned, each hip (whether dressing to the right or left); each man, except the base file, when on or near the new line executes **eyes right**, and taking steps of 2 or 3 inches, places himself so that his right arm rests lightly against the arm of the man on his right, and so that his eyes and shoulders are in line with those of the men on his right; the rear rank men cover in file.

The instructor verifies the alignment of both ranks from the right flank and orders up or back such men as may be in rear, or in advance, of the line; only the men designated move.

At the command **dress** all men place the left hand upon the man turns his head and eyes to the front and drops his left hand by his side.

In the first drills the basis of the alignment is established on, or parallel to, the front of the squad; afterwards, in oblique directions.

Whenever the position of the base file or files necessitates a considerable movement by the squad, such movement will be executed by marching to the front or oblique, to the flank or backward, as the case may be, without other command, and at the trail. (107)

155. To preserve the alignment when marching: **GUIDE RIGHT (LEFT).**

The men preserve their intervals from the side of the guide, yielding to pressure from that side and resisting pressure from the opposite direction; they recover intervals, if lost, by gradually opening out or closing in; they recover alignment by slightly lengthening or shortening the step; the rear-rank men cover their file leaders at 40 inches.

In double rank, the front-rank man on the right, or designated flank, conducts the march; when marching faced to the flank, the leading man of the front rank is the guide. (108)

To Take Intervals and Distances

156. Being in line at a halt: **1. Take interval, 2. To the right (left), 3. MARCH, 4. Squad, 5. HALT.**



Being in line at a halt.

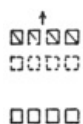

1. Take interval, 2. To the right (left)

At the second command the rear-rank men march backward 4 steps and halt;



3. MARCH

At the command **march** all face to the right and the leading man of each rank steps off; the other men step off in succession, each following the preceding man at 4 paces, rear-rank men marching abreast of their file leaders.

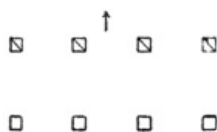

4. Squad, 5. HALT

At the command **halt**, given when all have their intervals, all halt and face to the front. (109)

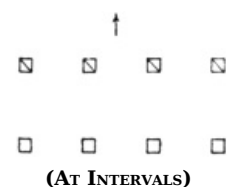

157. Being at intervals, to assemble the squad:

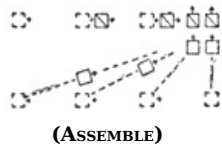

1. Assemble, to the right (left), 2. MARCH.

The front-rank man on the right stands fast, the rear rank man on the right closes to 40 inches. The other men face to the right, close by the shortest line, and face to the front. (110)

(ASSEMBLE)



(ASSEMBLED)

(AT DISTANCES)

158. Being in line at a halt and having counted off: 1. Take distance, 2. MARCH, 3. Squad, 4. HALT.

[Pg 52]

At the command **March** No. 1 of the front rank moves straight to the front; Nos. 2, 3, and 4 of the front rank and Nos. 1, 2, 3, and 4 of the rear rank, in the order named, move straight to the front, each stepping off so as to follow the preceding man at 4 paces. The command **halt** is given when all have their distances.

In case more than one squad is in line, each squad executes the movement as above. The guide of each rank of numbers is right. (111)

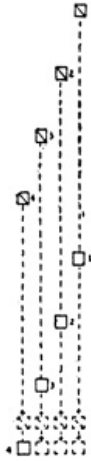

(IN LINE)

(ASSEMBLED)

159. Being at distances, to assemble the squad: 1. Assemble, 2. MARCH.

No. 1 of the front rank stands fast; the other numbers move forward to their proper places in line. (112)

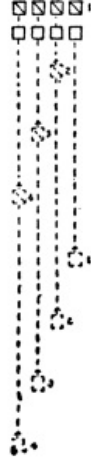

(AT DISTANCES)

To Stack and Take Arms



160. Being in line at a halt: STACK ARMS. Each even number of the front rank grasps his piece with the left hand at the upper band

and rests the butt between his feet, barrel to the front, muzzle inclined [Pg 53]



slightly to the front and opposite the center of the interval on his right, the thumb and forefinger raising the stacking swivel; each **even** number of the **rear** rank then passes his piece, barrel to the rear, to his file leader, who grasps it between the bands with his right hand



and throws the butt about 2 feet in advance of that of his own piece and opposite the right of the interval, the right hand slipping to the upper band, the thumb and forefinger raising the stacking swivel, which he engages with that of his own piece;



each **odd** number of the **front** rank raises his piece with the right hand, carries it well forward, barrel to the front; the left hand, guiding the stacking swivel,



engages the lower hook of the swivel of his own piece with the free hook of that of the even number of the rear rank; he then turns the barrel outward into the angle formed by the other two pieces and lowers the butt to the ground, **to the right and against the toe** of his right shoe.

[Pg 54]

The stacks made, the loose pieces are laid on them by the **even** numbers of the front rank. When each man has finished handling pieces, he takes the position of the soldier. (113)

161. Being in line behind the stacks: **TAKE ARMS.**

(See preceding illustration.)

The loose pieces are returned by the **even** numbers of the **front** rank; each even number of the front rank grasps his own piece with the left hand, the piece of his rear rank man with his right hand, grasping both between the bands; each **odd** number of the **front** rank grasps his piece in the same way with the right hand; disengages it by raising the butt from the ground and then turning the piece to the right, detaches it from the stack; each **even** number of the front rank disengages and detaches his piece by turning it to the left,

and, then passes the piece of his rear-rank man to him, and all resume the order. (114)



Should any squad have Nos. 2 and 3 blank files, No. 1 rear rank takes the place of No. 2 rear rank in making and breaking the stack; the stacks made or broken, he resumes his post. [Pg 55]

Pieces not used in making the stacks are termed **loose pieces**.

Pieces are never stacked with the bayonet fixed. (115)

The Oblique March

162. For the instruction of recruits, the squad being in column or correctly aligned, the instructor causes the squad to face half right or half left, points out to the men their relative positions, and explains that these are to be maintained in the oblique march. (116)

163. Right (Left) oblique, 2. MARCH.

AFTER OBLIQUING

Each man steps off in a direction 45° to the right of his original front. He preserves his relative position, keeping his shoulders parallel to those of the guide (the man on the right front of the line or column), and so regulates his steps that the ranks remain parallel to their original front.

At the command **halt** the men halt faced to front.

To resume the original direction: **1. Forward 2. MARCH.**

BEFORE OBLIQUING

The men half face to the left in marching and then move straight to the front.

If at **halfstep** or **mark time** while obliquing, the oblique march is resumed by the commands: **1. Oblique, 2. MARCH.** (117)

To Turn on Moving Pivot

164. Being in line: **1. Right (Left) turn, 2. MARCH.**

The movement is executed by each rank successively and on the same ground. At the second command, the pivot man of the front rank faces to the right in marching and takes the half step; the other men of the rank oblique to the right until opposite their places in line, then execute a second right oblique and take the half step on arriving abreast of the pivot man. All glance toward the marching flank while at half step and take the full step without command as the last man arrives on the line.

Right (Left) half turn is executed in a similar manner. The pivot man makes a half change of direction to the right and the other men make quarter changes in obliquing. (118)

To Turn on Fixed Pivot

165. Being in line, to turn and march: **1. Squad right (left), 2. MARCH.**

At the second command, the right flank man in the front rank faces to the right in marching and marks time; the other front rank men oblique to the right, place themselves abreast of the pivot, and mark time. In the rear rank the third man from the right, followed in column by the second and first, move straight to the front

(a)

[Pg 56]

until in rear of his front-rank man,

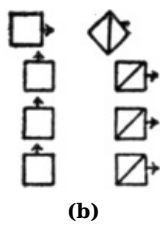

(b)

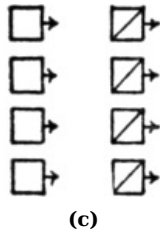

(c)

when all face to the right in marching and mark time; the other number of the rear rank moves straight to the front four paces and places himself abreast of the man on his right. Men on the new line glance toward the marching flank while marking time and, as the last man arrives on the line, both ranks execute **forward, MARCH**, without command. (119)

166. Being in line, to turn and halt: 1. Squad right (left), 2. MARCH, 3. Squad, 4. HALT.

The third command is given immediately after the second. The turn is executed as prescribed in the preceding paragraph except that all men, on arriving on the new line, mark time until the fourth command is given, when all halt. The fourth command should be given as the last man arrives on the line. (120)

167. Being in line, to turn about and march: 1. Squad right (left) about, 2. MARCH.

At the second command, the front rank twice executes squad right initiating the second squad right when the man on the marching flank has arrived abreast of the rank. In the rear rank the third man from the right, followed by the second and first in column, moves straight to the front until on the prolongation of the line to be occupied by the rear rank; changes direction to the right; moves in the new direction until in rear of his front-rank man, when all face to the right in marching, mark time, and glance toward the marching flank. The fourth man marches on the left of the third to his new position; as he arrives on the line, both ranks execute **forward, MARCH**, without command. (121)

[Pg 57]

168. Being in line, to turn about and halt: 1. Squad right (left) about, 2. MARCH, 3. Squad, 4. HALT.

The third command is given immediately after the second. The turn is executed as prescribed in the preceding paragraph except that all men, on arriving on the new line, mark time until the fourth command is given, when all halt. The fourth command should be given as the last man arrives on the line. (122)

To Follow the Corporal

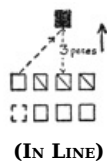

(IN LINE)

169. Being assembled or deployed, to march the squad without unnecessary commands, the corporal places himself in front of it and commands: FOLLOW ME.

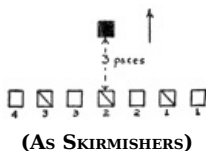

(AS SKIRMISHERS)

If in line or skirmish line, No. 2 of the front rank follows in the trace of the corporal at about 3 paces; the other men conform to the movements of No. 2, guiding on him and maintaining their relative positions.



(IN COLUMN)

If in column, the head of the column follows the corporal. (123)

To Deploy as Skirmishers

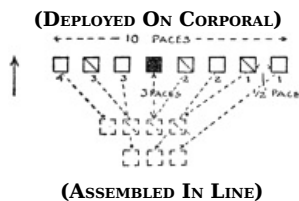

(In this diagram the corporal was in front of the squad before the movement began.)

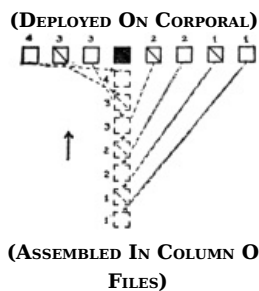

(DEPLOYED ON No. 2)

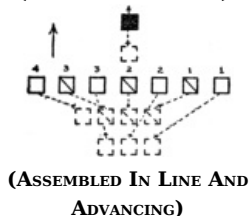

170. Being in any formation, assembled: **1. As skirmishers, 2. MARCH.**

The corporal places himself in front of the squad, if not already there. Moving at a run, the men place themselves abreast of the corporal at half-pace intervals, Nos. 1 and 2 on his right, Nos. 3 and 4 on his left, rear rank men on the right of their file leaders, extra men on the left of No. 4; all then conform to the corporal's gait.

[Pg 58]

When the squad is acting alone, skirmish line is similarly formed on No. 2 of the front rank, who stands fast or continues the march, as the case may be; the corporal places himself in front of the squad when advancing and in rear when halted.

When deployed as skirmishers, the men march at ease, pieces at the trail unless otherwise ordered.

The corporal is the guide when in the line; otherwise No. 2 front rank is the guide. (124)

171. The normal interval between skirmishers is one-half pace, resulting practically in one man per yard of front. The front of a squad thus deployed as skirmishers is about 10 paces. (125)

To Increase or Diminish Intervals

172. If assembled, and it is desired to deploy at greater than the normal interval; or if deployed, and it is desired to increase or decrease the interval: **1. As skirmishers, (so many) paces, 2. MARCH.**

Intervals are taken at the indicated number of paces. If already deployed, the men move by the flank toward or away from the guide. (126)

The Assembly

173. Being deployed: **1. Assemble. 2. MARCH.**

The men move toward the corporal and form in their proper places.

If the corporal continues to advance, the men move in double time, form, and follow him.

The assembly while marching to the rear is not executed. (127)

Kneeling and Lying Down

174. If standing: **KNEEL.**

Half face to the right; carry the right toe about 1 foot to the left rear of the left heel;

kneel on right knee, sitting as nearly as possible on the right heel; left forearm across left thigh; piece remains in position of order arms, right hand grasping it above lower band. (128)

[Pg 59]



175. If standing or kneeling: **LIE DOWN.**

Kneel, but with right knee against left heel:



carry back the left foot and lie flat on the belly, inclining body about 35° to the right



piece horizontal, barrel up, muzzle off the ground and pointed to the front; elbows on the ground; left hand at the balance, right hand grasping the small of the stock opposite the neck. This is the position of order arms, lying down. (129)

176. If kneeling or lying down: **RISE.**

[Pg 60]

If kneeling, stand up, faced to the front, on the ground marked by the left heel.

If lying down, raise body on both knees; stand up, faced to the front, on the ground marked by the knees. (130)

177. If lying down: **KNEEL.**

Raise the body on both knees; take the position of kneel. (131)

178. In double rank, the positions of kneeling and lying down are ordinarily used only for the better utilization of cover.

When deployed as skirmishers, a sitting position may be taken in lieu of the position kneeling. (132)

Loadings and Firings

179. The commands for loading and firing are the same whether standing, kneeling, or lying down. The firings are always executed at a halt.

When kneeling or lying down in double rank, the rear rank does not load, aim, or fire.

The instruction in firing will be preceded by a command for loading.

Loadings are executed in line and skirmish line only. (133)

180. Pieces having been ordered loaded are kept loaded without command until the command **unload**, or **inspection arms**, fresh clips being inserted when the magazine is exhausted. (To execute with Krag rifle see [par. 700.](#)) (134)

181. The aiming point or target is carefully pointed out. This may be done before or after announcing the sight setting. Both are indicated before giving the command for firing, but may be omitted when the target appears suddenly and is unmistakable; in such case battle sight is used if no sight setting is announced. (135)

182. The target or aiming point having been designated and the sight setting announced, such designation or announcement need not be repeated until a change of either or both is necessary.

Troops are trained to continue their fire upon the aiming point or target designated, and at the sight setting announced, until a change is ordered. (136)

183. If the men are not already in the position of load, that position is taken at the announcement of the sight setting; if the announcement is omitted, the position is taken at the first command for firing. (137)

184. When deployed, the use of the sling as an aid to accurate firing is discretionary with each man. (138)

To Load

185. Being in line or skirmish line at halt:

1. With dummy (blank or ball) cartridges, 2. LOAD.

[Pg 61]



At the command load each front-rank man or skirmisher faces half right and carries the right foot to the right, about 1 foot, to such position as will insure the greatest firmness and steadiness of the body; raises, or lowers, the piece and drops it into the left hand at the balance, the left thumb extended along the stock, muzzle at the height of the breast, and turns the cut-off up.



With the right hand he turns and draws the bolt back,



takes a loaded clip and inserts the end in the clip slots, places the thumb on the powder space of the top cartridge, the fingers extending around the piece and tips resting on the magazine floor plate; forces the cartridges into the magazine by pressing down with the thumb; without removing the clip, thrusts the bolt home, turning down the handle; turns the safety lock to the **"safe,"**

[Pg 62]

and carries the hand to the small of the stock.



Each rear rank man moves to the right front, takes a similar position opposite the interval to the right of his front rank man, muzzle of the piece extending beyond the front rank and loads.



A skirmish line may load while moving, the pieces being held as nearly as practicable in the position of **load**.



If kneeling or sitting, the position of the piece is similar; if kneeling, the left forearm rests on the left thigh;



if sitting the elbows are supported by the knees.

[Pg 63]



If lying down, the left hand steadies and supports the piece at the balance, the toe of the butt resting on the ground, the muzzle off the ground.

For reference, these positions (standing, kneeling, and lying down) are designated as that of **load**. (For Krag rifle as prescribed in 701.) (139)

186. For instruction in loading: **1. Simulate, 2. LOAD.**

Executed as above described except that the cut-off remains "off" and the handling of cartridges is simulated.

The recruits are first taught to **simulate** loading and firing; after a few lessons dummy cartridges may be used. Later, blank cartridges may be used. (140)

The rifle may be used as a single loader by turning the magazine "off." The magazine may be filled in whole or in part while "off" or "on" by pressing cartridges singly down and back until they are in the proper place. The use of the rifle as a single loader is, however, to be regarded as exceptional. (Explained for Krag rifle in [par. 702.](#)) (141)

To Unload

187. UNLOAD.

Take the position of load, turn the safety lock up and move bolt alternately back and forward until all the cartridges are ejected. After the last cartridge is ejected the chamber is closed by first thrusting the bolt slightly forward to free it from the stud holding it in place when the chamber is open, pressing the follower down and back to engage it under the bolt and then thrusting the bolt home; the trigger is pulled. The cartridges are then picked up, cleaned, and returned to the belt and the piece is brought to the order. (Explained in [par. 703](#) for Krag rifle.) (142)

To Set the Sight

188. RANGE, ELEVEN HUNDRED (EIGHT-FIFTY, etc.), or BATTLE SIGHT.

The sight is set at the elevation indicated. The instructor explains and verifies sight settings. (143)

To Fire by Volley

[Pg 64]

189. 1. Ready, 2. AIM, 3. Squad, 4. FIRE.

At the command **ready** turn the safety lock to the "ready";



at the command **aim** raise the piece with both hands and support the butt firmly against the hollow of the right shoulder, right thumb clasping the stock, barrel horizontal, left elbow well under the piece, right elbow as high as the shoulder; incline the head slightly forward and a little to the right, cheek against the stock,



left eye closed, right eye looking through the notch of the rear sight so as to perceive the object aimed at, second joint of the forefinger resting lightly against the front of the trigger and taking up the slack; top of front sight is carefully raised into, and held in, the line of sight.



Each rear-rank man aims through the interval to the right of his file leader and leans slightly forward to advance the muzzle of his piece beyond the front rank.

[Pg 65]



In aiming kneeling, the left elbow rests on the left knee, point of elbow in front of kneecap.



In aiming sitting, the elbows are supported by the knees.



In aiming, lying down, raise the piece with both hands; rest on both elbows and press the butt firmly against the right shoulder.



At the command **fire** press the finger against the trigger; fire without deranging the aim and without lowering or turning the piece; lower the piece in the position of **load** and load. (144)

[Pg 66]

To continue the firing: **1. AIM, 2. Squad, 3. FIRE.**

Each command is executed as previously explained. **Load** (from magazine) is executed by drawing back and thrusting home the bolt with the right hand, leaving the safety lock at the "ready." (145)

To Fire at Will

190. FIRE AT WILL.

Each man, independently of the others, comes to the **ready**, aims carefully and deliberately at the aiming point or target, **fires, loads**, and continues the firing until ordered to **suspend** or **cease firing**. (146)

191. To increase (decrease) the rate of fire in progress the instructor shouts: **FASTER (SLOWER).**

Men are trained to fire at the rate of about three shots per minute at effective ranges and five or six at close ranges, devoting the minimum of time to loading and the maximum to deliberate aiming. To illustrate the necessity for deliberation, and to habituate men to combat conditions, small and comparatively indistinct targets are designated. (147)

To Fire by Clip

192. CLIP FIRE.

Executed in the same manner as **fire at will**, except that each man, after having exhausted the cartridges then in the piece, **suspends firing**. (For Krag rifle see [par. 704.](#)) (148)

To Suspend Firing

193. The instructor blows a **long blast** of the whistle and repeats same, if necessary, or commands: **SUSPEND FIRING**.

Firing stops; pieces are held, loaded and locked, in a position of readiness for instant resumption of firing, rear sights unchanged. The men continue to observe the target or aiming point, or the place at which the target disappeared, or at which it is expected to reappear.

This whistle signal may be used as a preliminary to **cease firing**. (149)

To Cease Firing

194. CEASE FIRING.

Firing stops; pieces not already there are brought to the position of load; those not loaded, are loaded; sights are laid, pieces are locked and brought to the order.

Cease firing is used for long pauses, to prepare for changes of position, or to steady the men. (For Krag rifle see [par. 705.](#)) (150)

Commands for suspending or ceasing fire may be given at any time after the preparatory command for firing whether the firing has actually commenced or not. (151)

The Use of Cover

[Pg 67]

195. Individual instruction; things to be impressed upon the recruit. The recruit should be given careful instruction in the individual use of cover. (152)

It should be impressed upon him that, in taking advantage of natural cover, he must be able to fire easily and effectively upon the enemy; if advancing on an enemy, he must do so steadily and as rapidly as possible; he must conceal himself as much as possible while firing and while advancing. While setting his sight he should be under cover or lying prone.

196. Practice in simulated firing from behind hillocks, trees, etc.; firing around right side of concealment. To teach him to fire easily and effectively, at the same time concealing himself from the view of the enemy, he is practiced in simulated firing in the prone, sitting, kneeling, and crouching positions, from behind hillocks, trees, heaps of earth or rocks, from depressions, gullies, ditches, doorways, or windows. He is taught to fire around the right side of his concealment whenever possible, or, when this is not possible, to rise enough to fire over the top of his concealment.

When these details are understood, he is required to select cover with reference to an assumed enemy and to place himself behind it in proper position for firing. (153)

197. Evil of remaining too long in one place; advancing from cover to cover by running, crawling, etc. The evil of remaining too long in one place, however good the concealment, should be explained. He should be taught to advance from cover to cover, selecting cover in advance before leaving his concealment.

It should be impressed upon him that a man running rapidly toward an enemy furnishes a poor target. He should be trained in springing from a prone position behind concealment, running at top speed to cover and throwing himself behind it. He should also be practiced in advancing from cover to cover by crawling, or by lying on the left side, rifle grasped in the right hand, and pushing himself forward with the right leg. (154)

198. Action when fired on while acting independently. He should be taught that, when fired on while acting independently, he should drop to the ground, seek cover, and then endeavor to locate his enemy. (155)

199. Proper advance and effectiveness of fire of greater importance than cover. The instruction of the recruit in the use of cover is continued in the combat exercises of the company, but he must then be taught that the proper advance of the platoon or company and the effectiveness of its fire is of greater importance than the question of cover for individuals. He should also be taught that he may not move about or shift his position in the firing line except the better to see the target. (156)

Observation

200. Importance of observation; training of recruit. The ability to use his eyes accurately is of great importance to the soldier. The recruit should be trained in observing his surroundings from positions and when on the march.

[Pg 68]

He should be practiced in pointing out and naming military features of the ground; in distinguishing between living beings; in counting distant groups of objects or beings; in recognizing colors and forms. (157)

201. Training in mechanism of firing line and estimating distance. In the training of men in the mechanism of the firing line, they should be practiced in repeating to one another target and aiming point designations and in quickly locating and pointing out a designated target. They should be taught to distinguish, from a prone position, distant objects, particularly troops, both with the naked eye and with field glasses. Similarly, they should be trained in estimating distances. (158)

SCHOOL OF THE COMPANY

202. Captain responsible for instruction of officers and noncommissioned officers. The captain is responsible for the theoretical and practical instruction of his officers and noncommissioned officers, not only in the duties of their respective grades, but in those of the next higher grades. (159)

203. Formation of company in double rank, according to height; division into squads. The company in line is formed in double rank with the men arranged, as far as practicable, according to height from right to left, the tallest on the right.

The original division into squads is effected by the command: **COUNT OFF**. The squads, successively, from the right, count off as in the School of the Squad, as explained in [par. 153](#), corporals placing themselves as Nos. 4 of the front rank. If the left squad contains less than six men, it is either increased to that number by transfers from other squads or is broken up and its members assigned to other squads and posted in the line of file closers. These squad organizations are maintained, by transfers if necessary, until the company becomes so reduced in numbers as to necessitate a new division into squads. No squad will contain less than six men. (160)

204. Division of company into platoons. The company is further divided into two, three or four platoons, each consisting of not less than two, nor more than four squads. In garrison or ceremonies the strength of platoons may exceed four squads. (161)

205. Designation of squads and platoons. At the formation of the company the platoons or squads are numbered consecutively from right to left and these designations do not change.

For convenience in giving commands and for reference, the designations, **right, center, left**, when in line, and **leading, center, rear**, when in column, are applied to platoons or squads. These designations apply to the actual right, left, center, head, or rear, in whatever direction the company may be facing. The **center squad** is the middle or right middle squad of the company.

The designation "So-and-so's" squad or platoon may also be used. (162)

206. Assignment of platoons; assignment of guides. Platoons are assigned to the lieutenants and noncommissioned officers, in order of rank, as follows: 1, right; 2, left; 3, center (right center); 4, left center.

[Pg 69]

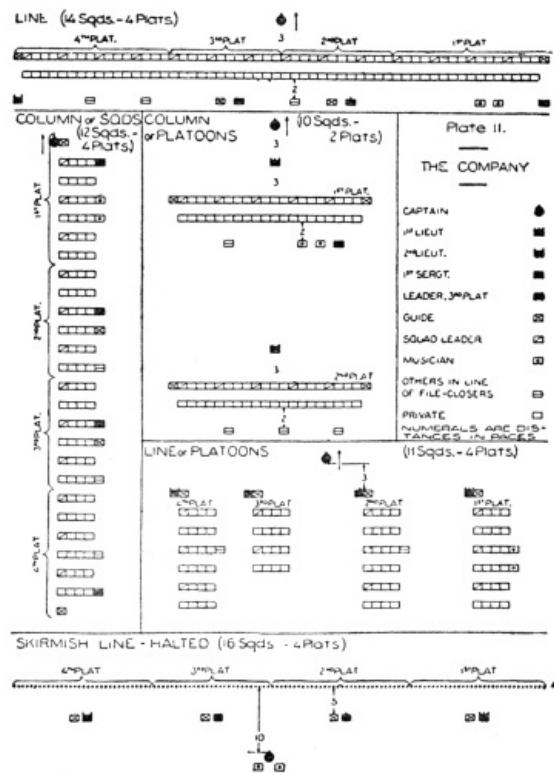

Plate II.

The noncommissioned officers next in rank are assigned as guides, one to each platoon. If sergeants still remain, they are assigned to platoons as additional guides. When the platoon is deployed, its guide, or guides, accompany the platoon leader.

During battle, these assignments are not changed; vacancies are filled by noncommissioned officers of the platoon, or by the nearest available officers or noncommissioned officers arriving with reinforcing troops. (163)

[Pg 70]

207. Post of first sergeant, quartermaster sergeant and musicians. The first sergeant is never assigned as a guide. When not commanding a platoon, he is posted as a file closer opposite the third file from the outer flank of the first platoon; and when the company is deployed he accompanies the captain.

The quartermaster sergeant, when present, is assigned according to his rank as a sergeant.

Enlisted men below the grade of sergeant, armed with the rifle are in ranks unless serving as guides; when not so armed they are posted in the line of file closers.

Musicians, when required to play, are at the head of the column. When the company is deployed, they accompany the captain, and perform the duties laid down in [par. 272](#). (164)

208. Certain movements executed by company and by platoon as prescribed in Schools of the Soldier and the Squad. The company executes the **halt, rests, facings, steps, and marchings, manual of arms, loadings, and firings, takes intervals and distances and assembles, increases and diminishes intervals, resumes attention, obliques, resumes the direct march, preserves alignments, kneels, lies down, rises, stacks, and takes arms**, as explained in the Schools of the Soldier and the Squad, substituting in the commands **company** for **squad**.

The same rule applies to platoons, detachments, details, etc., substituting their designation for **squad** in the commands. In the same manner these execute the movements prescribed for the company, whenever possible, substituting their designation for **company** in the commands. (165)

209. Depleted company led as platoon. A company so depleted as to make division into platoons impracticable is led by the captain as a single platoon, but retains the designation of company. The lieutenants and first sergeant assist in fire control; the other sergeants place themselves in the firing line as skirmishers. (166)

CLOSE ORDER

Rules

210. Platoon guides. The guides of the right and left, or leading and rear, platoons, are the right and left, or leading and rear, guides, respectively, of the company when it is in line or in column of squads. Other guides are in the line of **file closers**.

In platoon movements the post of the platoon guide is at the head of the platoon, if the platoon is in column, and on the guiding flank if in line. When a platoon has two guides their original assignment to flanks of the platoon does not change. (167)

211. Guides of a column of squads; changing guides and file closers to opposite flank. The guides of a column of squads place themselves on the flank opposite the file closers. To change the guides and file closers to the other flank, the captain commands: **1. File closers on left (right) flank; 2. MARCH.** The file closers dart through the column; the captain and guides change. [Pg 71]

In the column of squads, each rank preserves the alignment toward the side of the guide. (168)

212. File closers do not execute loadings or firings; execution of manual of arms and other movements. Men in the line of file closers do not execute the loadings or firings.

Guides and enlisted men in the line of file closers execute the manual of arms during the drill unless specially excused, when they remain at the order. During ceremonies they execute all movements. (169)

213. Action of guides in taking intervals and distances. In taking intervals and distances, unless otherwise directed, the right and left guides, at the first command, place themselves in the line of file closers, and, with them, take a distance of 4 paces from the rear rank. In taking intervals, at the command **march**, the file closers face to the flank and each steps off with the file nearest him. In assembling the guides and file closers resume their position in line. (170)

214. Repetition of commands by platoon leaders in platoon drill. In movements executed simultaneously by platoons (**as platoons right or platoons, column right**), platoon leaders repeat the preparatory command (**platoon right**, etc.), applicable to their respective platoons. The command of execution is given by the captain only. (171)

To Form the Company

215. At the sounding of the assembly the first sergeant takes position 6 paces in front of where the center of the company is to be, faces it, draws saber, and commands: **FALL IN.**

The right guide of the company places himself, facing to the front, where the right of the company is to rest, and at such point that the center of the company will be 6 paces from and opposite the first sergeant; the squads form in their proper places on the left of the right guide, superintended by the other sergeants, who then take their posts.

The first sergeant commands: **REPORT.** Remaining in position at the order, the squad leaders, in succession from right, salute and report: **All present;** or, **Private(s) — absent.** The first sergeant does not return the salutes of the squad leaders; he then commands: **1. Inspection, 2. ARMS, 3. Order, 4. ARMS,** faces about, salutes the captain, reports: **Sir, all present or accounted for,** or the names of the unauthorized absentees, and, without command, takes his post.

If the company can not be formed by squads, the first sergeant commands: **1. Inspection, 2. ARMS, 3. Right shoulder, 4. ARMS,** and calls the roll. Each man, as his name is called, answers here and executes order arms. The sergeant then effects the division into squads and reports the company as prescribed above.

The captain places himself 12 paces in front of the center of, and facing, the company in time to receive the report of the first sergeant, whose salute he returns, and then draws saber.

The lieutenants take their posts when the first sergeant has reported and draw saber with the captain. The company, if not under arms, is formed in like manner omitting reference to arms. (172) [Pg 72]

216. For the instruction of platoon leaders and guides, the company, when small, may be formed in single rank. In this formation close order movements only are executed. The single rank executes all movements as explained for the front rank of a company. (173)

To Dismiss the Company

217. Being in line at a halt, the captain directs the first sergeant: **Dismiss the company.** The officers fall out; the first sergeant places himself faced to the front, 3 paces to the front and 2 paces from the nearest flank of the company, salutes, faces toward opposite flank of the company and commands: **1. Inspection, 2. ARMS, 3. Port, 4. ARMS, 5. DISMISSED.** (174)

Alignments

218. The alignments are executed as prescribed in the School of the Squad, the guide being established instead of the flank file. The rear-rank man of the flank file keeps his head and eyes to the front and covers his file leader.

At each alignment the captain places himself in prolongation of the line, 2 paces from and facing the flank toward which the dress is made, verifies the alignment, and commands: **FRONT**.

Platoon leaders take a like position when required to verify alignments. (175)

Movements on the Fixed Pivot

219. Being in line, to turn the company: **1. Company right (left), 2. MARCH, 3. Company, 4. HALT;** or, **3. Forward, 4. MARCH.**

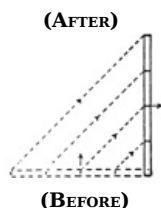

(For detail see diagram on [page 56](#))

At the second command the right-flank man^[1] in the front rank faces to the right in marching and marks time; the other front-rank men oblique to the right, place themselves abreast of the pivot, and mark time; in the rear rank the third man from the right, followed in column by the second and first, moves straight to the front until in rear of his front-rank man, when all face to the right in marching and mark time; the remaining men of the rear rank move straight to the front 4 paces, oblique to the right, place themselves abreast of the third man, cover their file leaders, and mark time, the right guide steps back, takes post on the flank, and marks time.

The fourth command is given when the last man is 1 pace in rear of the new line.

The command **halt** may be given at any time after the movement begins; only those halt who are in the new position. Each of the others halts upon arriving on the line, aligns himself to the right, and executes **front** without command. (176)

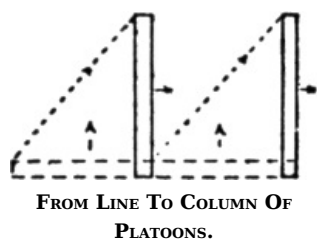

FROM LINE TO COLUMN OF
PLATOONS.

220. Being in line, to form column of platoons, or the reverse: **1. Platoons right (left), 2. MARCH, 3. Company, 4. HALT;** or, **3. Forward, 4. MARCH.**

[Pg 73]

Executed by each platoon as described for the company.

Before forming line the captain sees that the guides on the flank toward which the movement is to be executed are covering. This is effected by previously announcing the guide to that flank. (177)

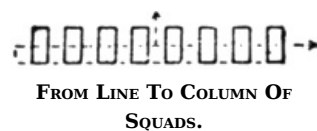

FROM LINE TO COLUMN OF
SQUADS.

221. Being in line, to form column of squads, or the reverse; or, being in line of platoons, to form column of platoons, or the reverse: **1. Squads right (left), 2. MARCH;** or, **1. Squads right (left), 2. MARCH, 3. Company, 4. HALT.**

Executed by each squad as described in the School of the Squad.

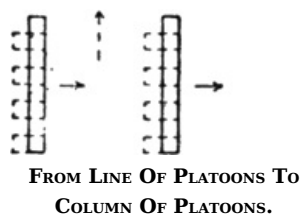

FROM LINE OF PLATOONS TO
COLUMN OF PLATOONS.

If the company or platoons be formed in line toward the side of the file closers, they dart through the column and take posts in rear of the company at the second command. If the column of squads be formed from line, the file closers take posts on the pivot flank, abreast of and 4 inches from the nearest rank. (178)

Movements on the Moving Pivot

(AFTER)

222. Being in line, to change direction: **1. Right (Left) turn, 2. MARCH, 3. Forward, 4. MARCH.**

Executed as described in the School of the Squad, except that the men do not glance toward the marching flank and that all take the full step at the fourth command. The right guide is the pivot of the front rank. Each rear-rank man obliques on the same ground as his file leader.

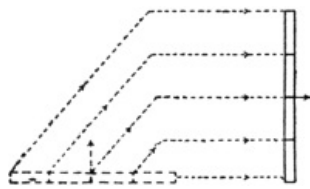

(BEFORE)

OUTLINE

223. Being in column of platoons, to change direction: **1. Column right (left), 2. MARCH.**

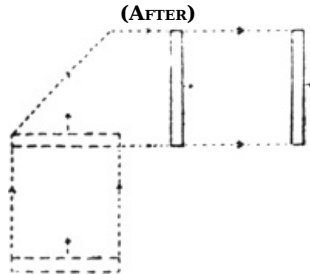

(BEFORE)

At the first command the leader of the leading platoon commands: **Right turn.** At the command **march** the leading platoon turns to the right on moving pivot; its leader commands: **1. Forward, 2. MARCH,** on completion of the turn. Rear **platoons** march squarely up to the turning point of the leading platoons **and turn** at command of their leaders. (180)

224. Being in column of squads, to change direction: **1. Column right (left), 2. MARCH.**

[Pg 74]

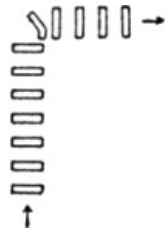

At the second command the front rank of the leading squad turns to the right on moving pivot as in the School of the Squad; the other ranks, without command turn successively on the same ground and in a similar manner. (181)

225. Being in column of squads, to form line of platoons or the reverse: **1. Platoons, column right (left), 2. MARCH.**

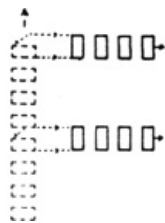

Executed by each platoon as described for the company. (182)

FROM COLUMN OF SQUADS TO LINE OF PLATOONS.

226. Being in line, to form column of squads and change direction: **1. Squads right (left), column right (left), 2. MARCH;** or, **1. Right (Left) by squads, 2. MARCH.**

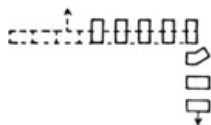

SQUADS RIGHT COLUMN RIGHT.

In the first case the right squad initiates the **column right** as soon as it has completed the **squad right.**

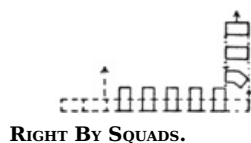

RIGHT BY SQUADS.

In the second case, at the command **march**, the right squad marches **forward**; the remainder of the company executes **squads right, column left**, and follows the right squad. The right guide, when he has posted himself in front of the squad, takes four short steps, then resumes the full step; the right squad conforms. (183)

227. Being in line, to form line of platoons: **1. Squads right (left), platoons, column right (left), 2. MARCH;** or, **1. Platoons, right (left) by squads, 2. MARCH.**

Executed by each platoon as described for the company in the

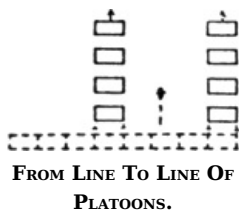

Facing or Marching to the Rear

228. Being in line, line of platoons, or in column of platoons or squads, to face or march to the rear: **1. Squads right (left) about, 2. MARCH;** or, **1. Squad right (left) about, 2. MARCH; 3. Company, 4. HALT.**

Executed by each squad as described in the School of the Squad.

If the company or platoons be in column of squads, the file closers turn about toward the column, and take their posts; if in line, each darts through the nearest interval between squads. (185).

229. To march to the rear for a few paces: **1. About, 2. FACE, 3. Forward, 4. MARCH.**

If in line, the guides place themselves in the rear rank, now the front rank; the file closers, on facing about, maintain their relative positions. No other movement is executed until the line is faced to the original front. (186)

On Right (Left) Into Line

230. Being in column of platoons or squads, to form line on right or left: **1. On right (left) into line, 2. MARCH, 3. Company, 4. HALT, 5. FRONT.**

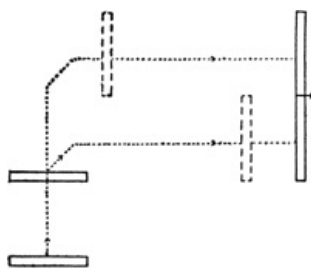

At the first command the leader of the leading unit commands: **Right turn.** The leaders of the other units command: **Forward,** if at a halt. At the second command the leading unit turns to the right on moving pivot. The command halt is given when the leading unit has advanced the desired distance in the new direction; it halts; its leader then commands: **Right dress.**

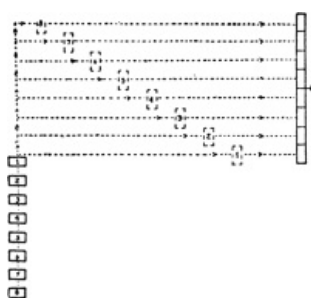

The units in rear continue to march straight to the front; each, when opposite the right of its place in line, executes right turn at the command of its leader; each is halted on the line at the command of its leader, who then commands: **Right dress.** All dress on the first unit in line.

If executed in double time, the leading squad marches in double time until halted. (187)

Front Into Line

231. Being in column of platoons or squads, to form line to the front: **1. Right (Left) front into line, 2. MARCH, 3. Company, 4. HALT, 5. FRONT.**

At the first command the leaders of the units in rear of the leading one command: **Right oblique.** If at a halt, the leader of the leading unit commands: **Forward.** At the second command the leading unit moves straight forward; the rear units oblique as indicated. The command **halt** is given when the leading unit has advanced the desired distance; it halts; its leader then commands: **Left dress.** Each of the rear units, when opposite its place in line, resumes the original direction at the command of its leader; each is halted on the line at the command of its leader, who then commands: **Left dress.** All dress on the first unit in line. (188)

232. Being in column of squads to form column of platoons, or being line of platoons, to form the company in line: **1. Platoons, right (left) front into line, 2. MARCH, 3. Company, 4. HALT, 5. FRONT.**



FROM COLUMN OF SQUADS TO LINE TO THE FRONT.

Executed by each platoon as described for the company. In forming the company in line, the dress is on the left squad of the left platoon. If forming column of platoons, platoon leaders verify the alignment before taking their posts; the captain commands **front** when the alignments have been verified.

When **front into line** is executed in double time the commands for halting and aligning are omitted and the guide is toward the side of the first unit in line. (189)

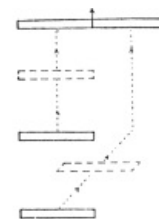

FROM COLUMN OF PLATOONS TO LINE TO THE FRONT.

At Ease and Route Step

233. The column of squads is the habitual column of route, but **route step** and **at ease** are applicable to any marching formation. (190)

To march at route step: **1. Route step, 2. MARCH.**

Sabers are carried at will or in the scabbard; the men carry their pieces at will, keeping the muzzles elevated; they are not required to preserve silence, nor to keep the step. The ranks cover and preserve their distance. If halted from route step, the men stand **at rest**. (191)

To march at ease: **1. At ease, 2. MARCH.**

The company marches as in route step, except that silence is preserved; when halted, the men remain **at ease**. (192)

Marching at route step or at ease: **1. Company, 2. ATTENTION.**

At the command **attention** the pieces are brought to the right shoulder and the cadenced step in quick time is resumed. (193)

To Diminish The Front of A Column of Squads

234. Being in column of squads: **1. Right (left) by twos, 2. MARCH.**



At the command **march** all files except the two right files of the leading squad execute **in place halt**; the two left files of the leading squad oblique to the right when disengaged and follow the right files at the shortest practicable distance. The remaining squads follow successively in like manner. (194)

235. Being in column of squads or twos: **1. Right (Left) by file, 2. MARCH.**

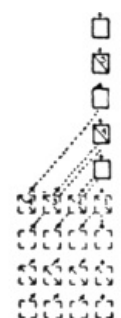

At the command **march**, all files execute **in place halt** except the right file of the leading two or squad. The left file or files of the leading two or squad oblique successively to the right when disengaged and each follows the file on its right at the shortest practicable distance. The remaining twos or squads follow successively in like manner. (195)

Being in column of files or twos, to form column of squads; or, being in column of files, to form column of twos: **1. Squads (Twos), right (left) front into line, 2. MARCH.**

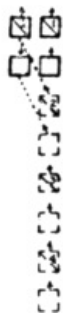
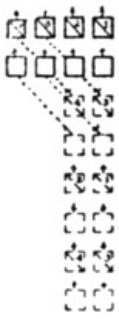

At the command **march**, the leading file or files halt. The remainder of the squad, or two, obliques to the right and halts on line with the leading file or files. The remaining squads or twos close up and successively form in rear of the first in like manner.

This diagram illustrates a squad executing **LEFT** front into line.

The movement described in this paragraph will be ordered **right** or **left**, so as to restore the files to their normal relative positions in the two or squad. (196)

The movements prescribed in the three preceding paragraphs are difficult of execution at attention and have no value as disciplinary exercises. (197)

EXTENDED ORDER

Rules for Deployment

236. Designation of base squads. The command **guide right (left or center)** indicates the base squad for the deployment; if in line it designates the actual **right (left or center)** squad; if in column the command **guide right (left)** designates the **leading** squad, and the command **guide center** designates the **center** squad, as laid down in [par. 205](#). After the deployment is completed, the guide is **center** without command, unless otherwise ordered. (199)

237. Action of squad leaders at preparatory command for forming skirmish line. At the preparatory command for forming skirmish line, from either column of squads or line, each squad leader (except the leader of the base squad, when his squad does not advance) cautions his squad, **follow me** or **by the right (left) flank**, as the case may be; at the command march, he steps in front of his squad and leads it to its place in line, as explained in [par. 169](#). (200)

238. Point on which base squad marches. Having given the command for forming skirmish line, the captain, if necessary, indicates to the corporal of the base squad the point on which the squad is to march; the corporal habitually looks to the captain for such directions. (201)

[Pg 78]

239. Deployment of the squads. The base squad ([par. 199](#)) is deployed as soon as it has sufficient interval. The other squads are deployed as they arrive on the general line; each corporal halts in his place in line and commands or signals, as **skirmishers** (executed as prescribed in [par. 170](#)); the squad deploys and halts abreast of him.

If tactical considerations demand it, the squad is deployed before arriving on the line. (202)

240. Alignment of deployed lines; deployed line faces to front on halting. Deployed lines preserve a general alignment toward the guide, as prescribed in [par. 65](#). Within their respective fronts, individuals or units march so as best to secure cover or to facilitate the advance, but the general and orderly progress of the whole is paramount.

On halting, a deployed line faces to the front (direction of the enemy) in all cases and takes advantage of cover, the men lying down if necessary. (203)

241. Certain movements in extended order executed by same commands as in close order. The company in skirmish line **advances, halts, moves by the flank, or to the rear, obliques, resumes the direct march, passes from quick to double time** and the reverse by the same commands and in a similar manner as in close order; if at a halt, the movement by **the flank or to the rear** is executed by the same commands as when marching. **Company right (left, half right, half left)** is executed as explained for the front rank (in [par. 165](#)) skirmish intervals being maintained. (See [par. 171](#).) (204)

242. Deployment of platoons and detachments. A platoon or other part of the company is deployed and marched in the same manner as the company, substituting in the commands, **platoon (detachments, etc.)**, for **company**. (205)

Deployments (See [pars. 170-172](#).)

243. Being in line, to form skirmish line to the front: **1. As skirmishers, guide right (left or center), 2. MARCH.**

If marching, the corporal of the base squad moves straight to the front; when that squad has advanced the desired distance, the captain commands: **1. Company, 2. HALT.** If the guide be **right (left)**, the other corporals move to the **left (right) front**, and, in

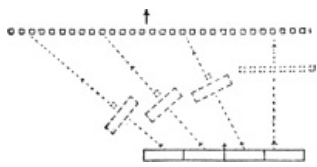

succession from the base, place their squads on the line; if the guide be center, the other corporals move to the right or left front, according as they are on the right or left of the center squad, and in succession from the center squad place their squads on the line.

If at a halt, the base squad is deployed without advancing; the other squads may be conducted to their proper places by the flank; interior squads may be moved when squads more distant from the base have gained comfortable marching distance. (206)

[Pg 79]

244. Being in column of squads, to form skirmish line to the front: 1. As skirmishers, guide right (left or center), 2. MARCH.

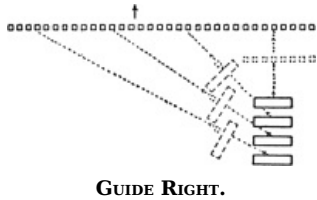

If marching, the corporal of the base squad deploys it and moves straight to the front; if at a halt, he deploys his squad without advancing. If the guide be **right (left)**, the other corporals move to the **left (right) front**, and, in succession from the base, place their squads on the line; if the guide be **center**, the corporals in front of the center squad move to the right (if at a halt, to the right rear), the corporals in rear of the center squad move to the left front, and each, in succession from the base, places his squad on the line.

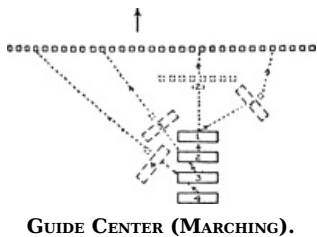

The column of twos or files is deployed by the same commands and in like manner. (207)

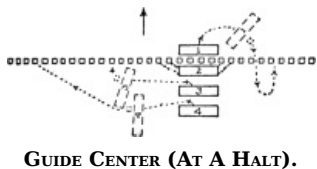

245. Deployment in an oblique direction. The company in line or in column of squads may be deployed in an oblique direction by the same commands. The captain points out the desire direction; the corporal of the base squad moves in the direction indicated; the other corporals conform. (208)

246. Deployment to flank or rear. To form skirmish line to the flank or rear the line or the column of squads is turned by squads to the flank or rear and then deployed as described. (209)

247. Increasing or decreasing intervals. The intervals between men are increased or decreased as described in the School of the Squad, as explained in [par. 172](#), adding to the preparatory command, **guide right (left or center)** if necessary, as explained in [par. 236](#). (210)

[Pg 80]

The Assembly

248. The captain takes his post in front of, or designates, the element on which the company is to assemble and commands: **1. Assemble, 2. MARCH.**

If in skirmish line the men move promptly toward the designated point and the company is reformed in line. If assembled by platoons, these are conducted to the designated point by platoon leaders, and the company is reformed in line.

Platoons may be assembled by the command: **1. Platoons, assemble, 2. MARCH.**

Executed by each platoon as described for the company.

One or more platoons may be assembled by the command: **1. Such platoon (s), assemble, 2. MARCH.**

Executed by the designated platoon or platoons as described for the company. (211)

The Advance

249. Methods of advancing. The advance of a company into an engagement (whether for

attack or defense) is conducted in close order, preferably column of squads, until the probability of encountering hostile fire makes it advisable to deploy. After deployment, and before opening fire, the advance of the company may be continued in skirmish line or other suitable formation, depending upon circumstances. The advance may often be facilitated, or better advantage taken of cover, or losses reduced by the employment of the **platoon** or **squad columns**, as laid down in [pars. 250-251](#), or by the use of a **succession of thin lines**, as explained in [par. 255](#). The selection of the method to be used is made by the captain or major, the choice depending upon conditions arising during the progress of the advance. If the deployment is found to be premature, it will generally be best to assemble the company and proceed in close order.

Patrols are used to provide the necessary security against surprise. (212)

250. Being in skirmish line: 1. Platoon columns, 2 MARCH.

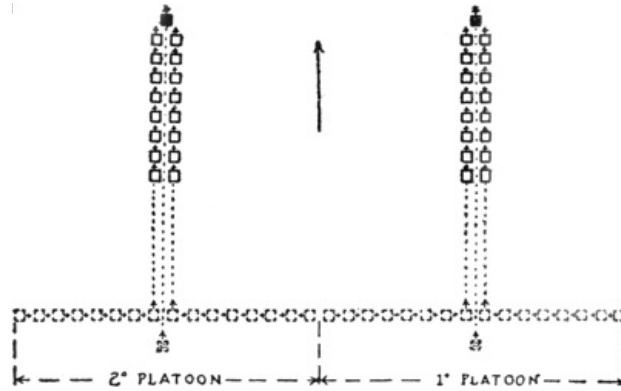

The platoon leaders move forward through the center of their respective platoons; men to the right of the platoon leader march to the left and follow him in file; those to the left march in like manner to the right; each platoon leader thus conducts the march of his platoon in double column of files; platoon guides follow in rear of their respective platoons to insure prompt and orderly execution of the advance. (213)

[Pg 81]

251. Being in skirmish line: 1. Squad columns, 2. MARCH.

Each squad leader moves to the front; the members of each squad oblique toward and follow their squad leader in single file at easy marching distances. (214)

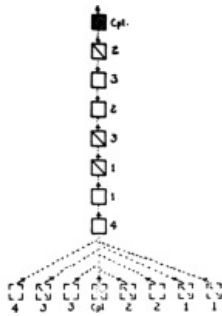

252. Platoon columns are profitably used where the ground is so difficult or cover so limited as to make it desirable to take advantage of the few favorable routes; no two platoons should march within the area of burst of a single shrapnel^[2]. **Squad columns** are of value principally in facilitating the advance over rough or brush-grown ground; they afford no material advantage in securing cover. (215)

253. To deploy platoon or squad columns: 1. As skirmishers, 2. MARCH.

Skirmishers move to the right or left front and successively place themselves in their original positions on the line. (216)

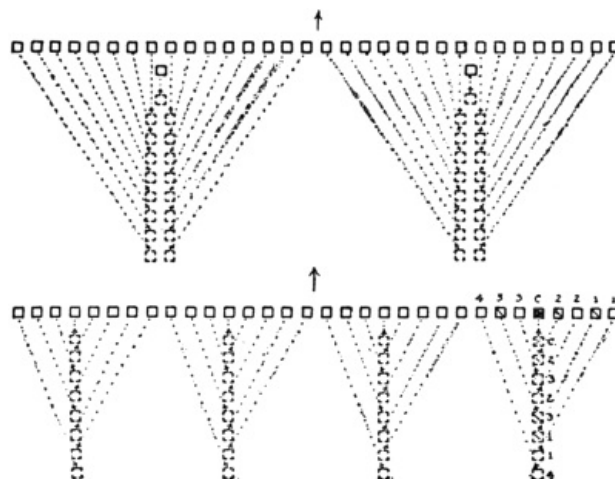

254. Being in platoon or squad columns: 1. Assemble, 2. MARCH.

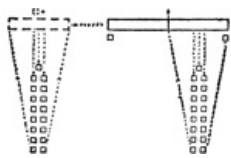

ASSEMBLY MADE ON RIGHT
PLATOON.

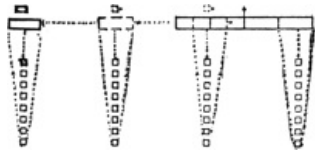

ASSEMBLY MADE ON RIGHT
SQUAD.

The platoon or squad leaders signal **assemble**. The men of each platoon or squad, as the case may be, advance and, moving to the right and left, take their proper places in line, each unit assembling on the leading element of the column and re-forming in line. The platoon or squad leaders conduct their units toward the element or point indicated by the captain, and to their places in line; the company is reformed in line. (217)

255. Being in skirmish line, to advance by a succession of **thin lines: 1. (Such numbers), forward, 2. MARCH.**

The captain points out in advance the selected position in front of the line occupied. The designated number of each squad moves to the front; the line thus formed preserves the original intervals as nearly as practicable; when this line has advanced a suitable distance (generally from 100 to 250 yards, depending upon the terrain and the character of the hostile fire), a second is sent forward by similar commands, and so on at irregular distances until the whole line has advanced. Upon arriving at the indicated position, the first line is halted. Successive lines, upon arriving, halt on line with the first and the men take their proper places in the skirmish line.

Ordinarily each line is made up of one man per squad and the men of a squad are sent forward in order from right to left as deployed. The first line is led by the platoon leader of the right platoon, the second by the guide of the right platoon, and so on in order from right to left.

The advance is conducted in quick time unless conditions demand a faster gait.

The company having arrived at the indicated position, a further advance by the same means may be advisable. (218)

256. Use and purpose of advance in succession of thin lines. The advance in a succession of thin lines is used to cross a wide stretch swept, or likely to be swept, by artillery fire or heavy, long-range rifle fire which cannot profitably be returned. Its purpose is the building up of a strong skirmish line preparatory to engaging in a fire fight. This method of advancing results in serious (though temporary) loss of control over the company. Its advantage lies in the fact that it offers a less definite target, hence is less likely to draw fire. (219)

257. Improvised formations. The above are suggestions. Other and better formations may be devised to fit particular cases. The best formation is the one which advances the line farthest with the least loss of men, time, and control. (220)

The Fire Attack

258. Advance of firing line; advance by rushes. The principles governing the advance of the firing line in attack are considered in the School of the Battalion. (See [par. 342-356.](#))

When it becomes impracticable for the company to advance as whole by ordinary means, it advances by rushes. (221)

259. Advancing by rushes. Being in skirmish line: **1. By platoon (two platoons, squad, four men, etc.), from the right (left), 2. RUSH.**

The platoon leader on the indicated flank carefully arranges the details for a prompt and vigorous execution of the rush and puts it into effect as soon as practicable. If necessary, he designates the leader for the indicated fraction. When about to rush, he causes the men of the fraction to cease firing and to hold themselves flat, but in readiness to spring forward instantly. The leader of the rush (at the signal of the platoon leader, if the latter be not the leader of the rush) commands: Follow me, and running at top speed, leads the fraction to the new line, where he halts it and causes it to open fire. The leader of the rush selects the new line if it has not been previously designated.

The first fraction having established itself on the new line, the next like fraction is sent forward by its platoon leader, without further command of the captain, and so on successively, until the entire company is on the line established by the first rush.

If more than one platoon is to join in one rush, the junior platoon leader conforms to the action of

the senior.

A part of the line having advanced, the captain may increase or decrease the size of the fractions to complete the movement. (222)

260. Rush of company as whole led by captain. When the company forms a part of the firing line, the rush of the company as a whole is conducted by the captain, as described for a platoon in the preceding paragraph. The captain leads the rush; platoon leaders lead their respective platoons; platoon guides follow the line to insure prompt and orderly execution of the advance. (223)

261. Advance by crawling or otherwise. When the foregoing method of rushing, by running, becomes impracticable, any method of advance that **brings the attack closer to the enemy**, such as crawling, should be employed.

For regulations governing the charge, see [paragraphs 355](#) and [356](#). (224)

(All rushes should be made with life and ginger, and all the men should start together. All rushes should be made under covering fire, and when a unit rushes forward the adjoining unit or units make up for the loss of fire thus caused by increasing the rate of their fire.)

A unit commander about to rush forward, will not do so until he sees that the adjoining unit or units have started to give him the protection of their covering fire and, if necessary, he will call to them to do so. Each unit must be careful not to advance until the last unit that rushed forward has had time to take up an effective fire. When sights have to be adjusted at the conclusion of a rush, the men should do so in the prone position even though it be necessary for the men to kneel for firing. The same as the men who rush should start simultaneously from the prone position, so should they stop simultaneously, all men dropping down to the ground together, wherever they may be, at the command "Down," given by the unit commander when the leading men have reached the new position. The slower members who drop down in rear will crawl up to the line after the halt. So that the slower members may not be crowded out of the line, and also to prevent bunching, the faster men should leave room for them on the line.—Author.)

[Pg 84]

The Company in Support

(Being part of a battalion)

262. Formations adopted by support. To enable it to follow or reach the firing line, the support adopts suitable formations, following the principles explained in [paragraphs 249-255](#).

The support should be kept assembled as long as practicable. If after deploying a favorable opportunity arises to hold it for some time in close formation, it should be reassembled. It is redeployed when necessary. (225)

263. Support controlled by major: size of reënforcement; captain on look out for major's signals. The movements of the support as a whole and the dispatch of reënforcements from it to the firing line are controlled by the major.

A reënforcement of less than one platoon has little influence and will be avoided whenever practicable. (See [par. 353](#).)

The captain of a company in support is constantly on the alert for the major's signals or commands. (226)

264. Reënforcement to join firing line deployed as skirmishers and occupy existing intervals. A reënforcement sent to the firing line joins it deployed as skirmishers. The leader of the reënforcement places it in an interval in the line, if one exists, and commands it thereafter as a unit. If no such suitable interval exists, the reënforcement is advanced with increased intervals between skirmishers; each man occupies the nearest interval in the firing line, and each then obeys the orders of the nearest squad leader and platoon leader. (227)

265. Promptness in reënforcing firing line. A reënforcement joins the firing line as quickly as possible without exhausting the men. (228)

266. Original platoon divisions to be maintained; duties of officers and sergeants upon joining firing line. The original platoon division of the companies in the firing line should be maintained and should not be broken up by the mingling of reënforcements.

Upon joining the firing line, officers and sergeants accompanying a reënforcement take over the duties of others of like grade who have been disabled, or distribute themselves so as best to exercise their normal functions. Conditions will vary and no rules can be prescribed. It is

The Company Acting Alone

267. Employed according to principles of battalion acting alone. In general, the company, when acting alone, is employed according to the principles applicable to the battalion acting alone as laid down in [pars. 327-363](#); the captain employs platoons as the major employs companies, making due allowance for the difference in strength.

The support may be smaller in proportion or may be dispensed with. (230)

[Pg 85]

268. Protection against surprise. The company must be well protected against surprise. Combat patrols on the flanks are especially important as explained in [par. 410](#). Each leader of a flank platoon details a man to watch for the signals of the patrol or patrols on his flank. (231)

FIRE

269. Issuing of ammunition and loading of pieces before deployment; firings in close order. Ordinarily pieces are loaded and extra ammunition is issued before the company deploys for combat.

In close order the company executes the firings, as prescribed in [pars. 179-194](#), at the command of the captain, who posts himself in rear of the center of the company.

Usually the firings in close order consist of saluting volleys only. (See [par. 189](#) for volley firing.) (232)

270. Firing controlled by platoon leaders. When the company is deployed, the men execute the firings at the command of their platoon leaders; the latter give such commands as are necessary to carry out the captain's directions, and, from time to time, add such further commands as are necessary to continue, correct, and control, the fire ordered. (233)

271. Use of signals during firing. The voice is generally inadequate for giving commands during fire and must be replaced by signals of such character that proper fire direction and control is assured. (See [par. 92](#) for signals; [pars. 285-286](#) for fire direction and [pars. 287-290](#) for fire control.) To attract attention, signals must usually be preceded by the whistle signal (short blast). A fraction of the firing line about to rush should, if practicable, avoid using the long blast signal as an aid to cease firing. (See [par. 91](#).) Officers and men behind the firing line can not ordinarily move freely along the line, but must depend on mutual watchfulness and the proper use of the prescribed signals. All should post themselves so as to see their immediate superiors and subordinates. (234)

272. Duties of musicians. The musicians assist the captain by observing the enemy, the target, and the fire-effect, by transmitting commands or signals, and by watching for signals. (For posts of musicians see [par. 207](#).) (235)

273. Blank Cartridges. Firing with blank cartridges at an outlined or represented enemy ([par. 7](#)) at distances less than 100 yards is prohibited. (236)

274. Effect of fire and influence of ground. The effect of fire and the influence of the ground in relation thereto, and the individual and collective instruction in marksmanship, are treated in the Small-Arms Firing Manual. (237)

Ranges

275. Classification. For convenience of reference, ranges are classified as follows:

- 0 to 600 yards, close range.
- 600 to 1,200 yards, effective range.
- 1,200 to 2,000 yards, long range.
- 2,000 yards and over, distant range. (238)

[Pg 86]

276. Determination of distance to target. The distance to the target must be determined as accurately as possible and the sights set accordingly. Aside from training and morale, this is the most important single factor in securing effective fire at the longer ranges. (239)

277. Method of determining the range; estimators.

Except in a deliberately prepared defensive position, the most accurate and only practicable method of determining the range will generally be to take the mean of several estimates.

Five or six officers or men, selected from the most accurate estimators in the company, are designated as *range estimators* and are specially trained in estimating distances.

Whenever necessary and practicable, the captain assembles the range estimators, points out the target to them, and adopts the mean of their estimates. The range estimators then take their customary posts. (240)

Classes of Firing

278. Volley firing, as explained in [par. 189](#), has limited application. In defense it may be used in the early stages of the action if the enemy presents a large compact target. It may be used by troops executing **fire of position**, as set forth in [par. 438](#). When the ground near the target is such that the strike of bullets can be seen from the firing line, **ranging volleys** may be used to correct the sight setting.

In combat, volley firing is executed habitually by platoon. (241)

279. Fire at will, as explained in [par. 190](#), is the class of fire normally employed in attack or defense. (242)

280. Clip fire (see [par. 192](#).) has limited application. It is principally used: 1. In the early stages of combat, to steady the men by habituating them to brief pauses in firing. 2. To produce a short burst of fire. (243)

The Target

281. Assignment of target by major; change of target to be avoided; hostile firing line usual target. Ordinarily the major will assign to the company an objective in attack or sector in defense; the company's target will lie within the limits so assigned. In the choice of target, tactical considerations are paramount; the nearest hostile troops within the objective or sector will thus be the usual target. This will ordinarily be the hostile firing line; troops in rear are ordinarily proper targets for artillery, machine guns, or, at times, infantry employing fire of position, as set forth in [par. 438](#).

Change of target should not be made without excellent reasons therefor, such as the sudden appearance of hostile troops under conditions which make them more to be feared than the troops comprising the former target. (244)

282. Distribution of fire; allotment of target to platoon leaders. The distribution of fire over the entire target is of special importance.

The captain allots a part of the target to each platoon, or each platoon leader takes as his target that part which corresponds to his position in the company. Men are so instructed that each fires on that part of the target which is directly opposite him. (245)

[Pg 87]

283. All Parts of target equally important. All parts of the target are equally important. Care must be exercised that the men do not slight its less visible parts. A section of the target not covered by fire represents a number of the enemy permitted to fire coolly and effectively. (246)

284. Use of aiming points in case of invisible targets.

If the target can not be seen with the naked eye, platoon leaders select an object in front of or behind it, designate this as the *aiming target*, and direct a sight setting which will carry the cone of fire into the target. (247)

Fire Direction^[3]

285. Impracticability in combat of commanding company directly. When the company is large enough to be divided into platoons, it is impracticable for the captain to command it directly in combat. His efficiency in managing the firing line is measured by his ability to enforce his will through the platoon leaders. Having indicated clearly what he desires them to do, he avoids interfering except to correct serious errors or omissions. (248)

286. Captain directs the fire. The captain **directs** the fire of the company or of designated platoons. He designates the target, and, when practicable, allots a part of the target to each platoon, as prescribed in [par. 340](#). Before beginning the fire action he determines the range, as explained in [par. 277](#), announces the sight setting, as prescribed in [par. 188](#), and indicates the class of fire to be employed (See [par. 278](#)) and the time to open fire. Thereafter, he observes the fire effect (See [pars. 428-429](#)), corrects material errors in sight setting, prevents exhaustion of the ammunition supply, as explained in [par. 432-433](#), and causes the distribution of such extra

ammunition as may be received from the rear. (249)

Fire Control

287. Platoon the fire unit. In combat, the platoon is the fire unit. From 20 to 35 rifles are as many as one leader can control effectively. (250)

288. Special duties of platoon leaders. Each platoon leader puts into execution the commands or directions of the captain, having first taken such precautions to insure correct sight setting and clear description of the target or aiming target as the situation permits or requires; thereafter, he gives such additional commands or directions as are necessary to exact compliance with the captain's will. He corrects the sight setting when necessary. He designates an aiming target when the target can not be seen with the naked eye. (251)

289. General duties of platoon leaders; duties of platoon guides and squad leaders. In general, **platoon leaders** observe the target and the effect of their fire and are on the alert for the captain's commands or signals; they observe and regulate the rate of fire, as laid down in [par. 191](#). The **platoon guides** watch the firing line and check every breach of fire discipline. (See [pars. 291-294](#).) **Squad leaders** transmit commands and signals when necessary, observe the conduct of their squads and abate excitement, assist in enforcing fire discipline and participate in the firing. (252)

[Pg 88]

290. Importance of fire control. The best troops are those that submit longest to fire control. Loss of control is an evil which robs success of its greatest results. To avoid or delay such loss should be the constant aim of all.

Fire control implies the ability to stop firing, change the sight setting and target, and resume a well directed fire. (253)

Fire Discipline

291. What fire discipline implies. "Fire discipline implies, besides a habit of obedience, a control of the rifle by the soldier, the result of training, which will enable him in action to make hits instead of misses. It embraces taking advantage of the ground; care in setting the sight and delivery of fire; constant attention to the orders of the leaders, and careful observation of the enemy; an increase of fire when the target is favorable, and a cessation of fire when the enemy disappears; economy of ammunition." (See [pars. 432-433](#).) (Small-Arms Firing Manual.)

In combat, shots which graze the enemy's trench or position and thus reduce the effectiveness of his fire have the approximate value of hits; such shots only, or actual hits, contribute toward fire superiority.

Fire discipline implies that, in a firing line without leaders, each man retains his presence of mind and directs effective fire upon the proper target. (254)

292. Rate of fire. To create a correct appreciation of the requirements of fire discipline, men are taught that the rate of fire, as prescribed in [par. 191](#), should be as rapid as is consistent with accurate aiming; that the rate will depend upon the visibility, proximity, and size of the target; and that the proper rate will ordinarily suggest itself to each trained man, usually rendering cautions or commands unnecessary.

In attack the highest rate of fire is employed at the halt preceding the assault, and in pursuing fire. (See [pars. 490-494](#).) (255)

293. Position fire in advance by rushes. In an advance by rushes, as explained in [par. 259](#), leaders of troops in firing positions are responsible for the delivery of heavy fire to cover the advance of each rushing fraction. Troops are trained to change slightly the direction of fire so as not to endanger the flanks of advanced portions of the firing line. (256)

294. Action in defense, when target disappears. In defense, when the target disappears behind cover, platoon leaders suspend fire, as prescribed in [par. 193](#), prepare their platoons to fire upon the point where it is expected to reappear, and greet its reappearance instantly with vigorous fire. (257)

SCHOOL OF THE BATTALION

295. Battalion a tactical unit; duties and responsibilities of major. The battalion being purely a tactical unit, the major's duties are primarily those of an instructor in drill and tactics and of a tactical commander. He is responsible for the theoretical and practical training of the battalion. He supervises the training of the companies of the battalion with a view to insuring the thoroughness and uniformity of their instruction.

[Pg 89]

In the instruction of the battalion as a whole, his efforts will be directed chiefly to the development of tactical efficiency, devoting only such time to the mechanism of drill and to the ceremonies as may be necessary in order to insure precision, smartness, and proper control. (258)

296. Movements explained for battalion of four companies. The movements explained herein are on the basis of a battalion of four companies; they may be executed by a battalion of two or more companies, not exceeding six. (259)

297. Arrangement of companies in formations. The companies are generally arranged from right to left according to the rank of the captains present at the formation. The arrangement of the companies may be varied by the major or higher commander.

After the battalion is formed, no cognizance is taken of the relative order of the companies. (260)

298. Designation of companies. In whatever direction the battalion faces, the companies are designated numerically from right to left in line, and from head to rear in column, **first company, second company**, etc.

The terms **right** and **left** apply to actual right and left as the line faces; if the about by squads be executed when in line, the right company becomes the left company and the right center becomes the left center company.

The designation center company indicates the right center or the actual center company according as the number of companies is even or odd. (261)

299. Post of special units. The band and other special units, when attached to the battalion, take the same post with respect to it as if it were the nearest battalion. (262)

CLOSE ORDER

Rules

300. Repetition of commands by captains. Captains repeat such preparatory commands as are to be immediately executed by their companies, as **forward, squads right**, etc.; the men execute the commands **march, halt**, etc., if applying to their companies, when given by the major. In movements executed in route step or at ease the captains repeat the command of execution, if necessary. Captains do not repeat the major's commands in executing the manual of arms, nor those commands which are not essential to the execution of a movement by their companies, as **column of squads, first company, squads right**, etc.

In giving commands or cautions captains may prefix the proper letter designations of their companies, as **A Company, HALT; B Company, squads right**, etc. (263)

301. Captains repeating command for guide. At the command **guide center (right or left)**, captains command: **Guide right or left**, according to the positions of their companies. **Guide center** designates the left guide of the center company, as explained in 3d Sec. [par. 298](#). (264)

[Pg 90]

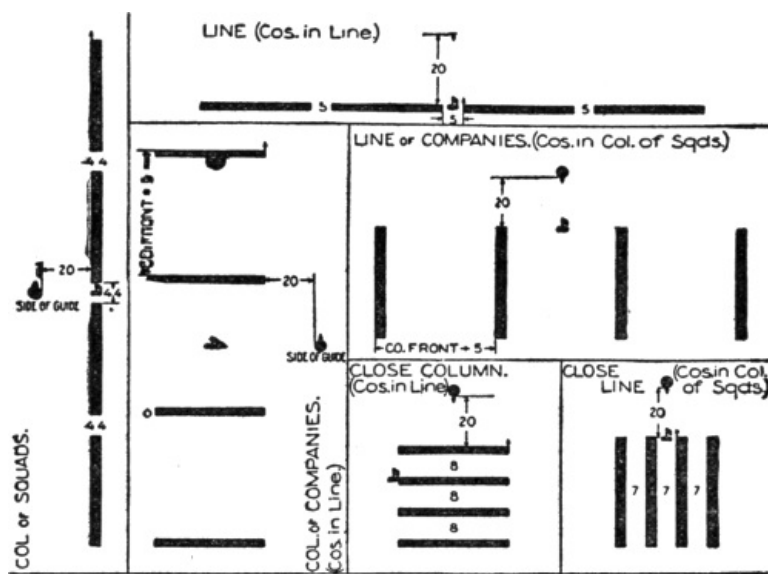

Plate III. MAJOR (WITH STAFF ETC.) - ● GUIDE AND DIRECTION - † THE COLOR - ▽
NUMERALS ARE DISTANCES OR INTERVALS IN PACES.

PLATE III.

302. Position of captains in dressing companies; action of guides in dressing. When the

companies are to be dressed, captains place themselves on that flank toward which the dress is to be made, as follows:

The battalion in line: Besides the guide (or the flank file of the front rank, if the guide is not in line) and facing to the front.

The battalion in column of companies: Two paces from the guide, in prolongation of and facing down the line.

Each captain, after dressing his company, commands: **FRONT**, and takes his post.

The battalion being in line and unless otherwise prescribed, at the captain's command **dress** or at the command **halt**, when it is prescribed that the company shall dress, the guide on the flank away from the point of rest with his piece at right shoulder, dresses promptly on the captain and the companies beyond. During the dress he moves, if necessary, to the right and left only; the captain dresses the company on the line thus established. The guide takes the position of order arms at the command **front**. (265)

303. Certain movements executed as in Schools of the Soldier, Squad and Company. The battalion executes the **halt** (See [par. 116](#)), **rests** (See [pars. 100-101](#)), **facings** (See [par. 104](#)), **steps** and **marchings** (See [pars. 107-109](#)), **manual of arms** (See [pars. 120-147](#)), resumes **attention** (See [par. 102](#)), **kneels** (See [pars. 174-177](#)), **lies down** (See [par. 175](#)), **rises** (See [par. 176](#)), **stacks** and **takes arms** (See [pars. 160-161](#)), as explained in the Schools of the Soldier and Squad, substituting in the commands **battalion** for **squad**.

[Pg 91]

The battalion executes **squads right (left)** (See [par. 221](#)), **squads right (left) about** (See [par. 228](#)), **route step** and **at ease** (See [par. 233](#)), and **obliques** and resumes the **direct march** (See [pars. 162-163](#)), as explained in the School of the Company. (266)

304. Certain movements executed as in School of the Company. The battalion in column of platoons, squads, twos, or files changes direction. (See [pars. 223-224](#)); in column of squads, forms column of twos or files and re-forms columns of twos or squads, as explained in the School of the Company. (See [pars. 234-235](#).) (267)

305. Simultaneous execution by companies or platoons of movements in School of the Company. When the formation admits of the simultaneous execution by companies or platoons of movements in the School of the Company the major may cause such movement to be executed by prefixing, when necessary, **companies (platoons)** to the commands prescribed therein: As **1. Companies, right front into line, 2. MARCH**. To complete such simultaneous movements, the commands **halt** or **march**, if prescribed, are given by the major. The command **front**, when prescribed, is given by the captains. (See [par. 302](#).) (268)

306. Execution of loadings and firings by battalion. The battalion as a unit executes the loadings and firings only in firing saluting volleys. The commands are as for the company, substituting **battalion** for **company**. At the first command for loading, captains take post in rear of the center of their respective companies. At the conclusion of the firing, the captains resume their posts in line.

On other occasions, when firing in close order is necessary, it is executed by company or other subdivision, under instructions from the major, as prescribed in [pars. 179-194](#). (269)

To Form the Battalion

307. For purposes other than ceremonies: The battalion is formed in column of squads. The companies having been formed, the adjutant posts himself so as to be facing the column, when formed, and 6 paces in front of the place to be occupied by the leading guide of the battalion; he draws saber; **adjutant's call** is sounded or the adjutant signals **assemble**.

The companies are formed, at attention, in column of squads in their proper order. Each captain, after halting his company, salutes the adjutant; the adjutant returns the salute and, when the last captain has saluted, faces the major and reports: **Sir, the battalion is formed**. He then joins the major. (270)

308. For ceremonies or when directed: The battalion is formed in line.

The companies having been formed, the adjutant posts himself so as to be 6 paces to the right of the right company when line is formed, and faces in the direction in which the line is to extend. He draws saber; **adjutant's call** is sounded; the band plays if present.

The right company is conducted by its captain so as to arrive from the rear, parallel to the line; its right and left guides precede it on the line by about 20 paces, taking post facing to the right at order arms, so that their elbows will be against the breasts of the right and left files of their company when it is dressed. The guides of the other companies successively prolong the line to

[Pg 92]

the left in like manner and the companies approach their respective places in line as explained for the right company. The adjutant, from his post, causes the guides to cover.

When about 1 pace in rear of the line, each company is halted and dressed to the right against the arms of the guides. (See [par. 302.](#))

The band, arriving from the rear, takes its place in line when the right company is halted; it ceases playing when the left company has halted.

When the guides of the left company have been posted, the adjutant, moving by the shortest route, takes post facing the battalion midway between the post of the major and the center of the battalion.

The major, staff, noncommissioned staff, and orderlies take their posts, as prescribed in [pars. 73; 76-78.](#)

When all parts of the line have been dressed, and officers and others have reached their posts, the adjutant commands: **1. Guides, 2. POSTS, 3. Present, 4. ARMS.** At the second command guides take their places in the line. ([Plate II](#), page 69.) The adjutant then turns about as explained in [par. 74](#), and reports to the major: **Sir, the battalion is formed**, as prescribed in [par. 75](#); the major directs the adjutant: **Take your post, Sir**; draws saber and brings the battalion to the **order**. The adjutant takes his post, passing to the right of the major. (271)

To Dismiss the Battalion

309. Dismiss your companies.

Staff and noncommissioned staff officers fall out; each captain marches his company off and dismisses it, as laid down in [par. 217.](#) (272)

To Rectify the Alignment

310. Being in line at a halt, to align the battalion: **1. Center (right or left), 2. DRESS.**

The captains dress their companies successively toward the center (right or left) guide of the battalion, each as soon as the captain next toward the indicated guide commands: **FRONT.** The captains of the center companies (if the dress is **center**) dress them without waiting for each other. (273)

311. To give the battalion a new alignment: **1. Guides center (right or left) company on the line, 2. Guides on the line, 3. Center (right or left), 4. DRESS, 5. Guides, 6. POSTS.**

At the first command, the designated guides place themselves on the line, as prescribed in [par. 308](#), facing the center (right or left). The major establishes them in the direction he wishes to give the battalion.

At the second command, the guides of the other companies take posts, facing the center (right or left), so as to prolong the line.

At the command **dress**, each captain dresses his company to the flank toward which the guides of his company face, taking the positions prescribed in [par. 302.](#) [Pg 93]

At the command **posts**, given when all companies have completed the dress, the guides return to their posts. ([Plate II](#), page 69.) (274)

To Rectify the Column

312. Being in column of companies, or in close column, at a halt, if the guides do not cover or have not their proper distances, and it is desired to correct them, the major commands: **1. Right (left), 2. DRESS.**

Captains of companies in rear of the first place their right guides so as to cover at the proper distance; each captain aligns his company to the right and commands: **FRONT.** (See [par. 302.](#)) (275)

On Right (Left) Into Line

313. Being in column of squads or companies: **1. On right (left) into line, 2. MARCH, 3.**

Battalion, 4. HALT.

Being in column of squads: At the first command, the captain of the leading company commands: **Squads right**. If at a halt each captain in rear commands: **Forward**. At the second command, the leading company marches in line to the right; the companies in rear continue to march to the front and form successively on the left, each, when opposite its place, being marched in line to the right.

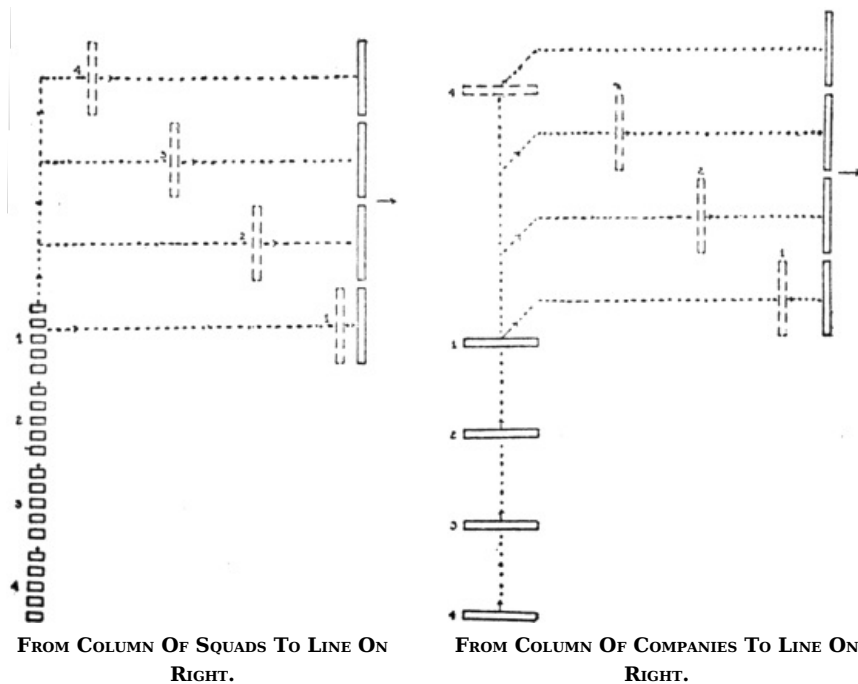

The fourth command is given when the first company has advanced the desired distance in the new direction; it halts and is dressed to the right by its captain ([par. 265](#)); the others complete the movement, each being halted 1 pace in rear of the line established by the first company, and then dressed to the right.

[Pg 94]

Being in column of companies: At the first command, the captain of the first company commands: **Right turn**. If at a halt, each captain in rear commands: **Forward**. Each of the captains in rear of the leading company gives the command: **1. Right turn**, in time to add, **2. MARCH**, when his company arrives opposite the right of its place in line.

The fourth command is given and the movement completed as explained above.

Whether executed from column of squads or column of companies, each captain places himself so as to march beside the right guide after his company forms line or changes direction to the right.

If executed in double time, the leading company marches in double time until halted. (276)

Front into Line

314. Being in column of squads or companies: **1. Right (left) front into line, 2. MARCH.**



Being in column of squads: At the first command, the captain of the leading company commands: **Column right**; the captain of the companies in rear: **column half right**. At the second command the leading company executes **column right**, and, as the last squad completes the change of direction, is formed in line to the left, as prescribed in [par. 221](#), halted and dressed to the left. (See [par. 302](#).) Each of the companies in rear is conducted by the most convenient route to the rear of the right of the preceding company, thence to the right, parallel to and 1 pace in rear of the new line; when opposite its place, it is formed in line to the left, halted, and dressed to the left.

Being in column of companies: If marching, the captain of the leading company gives the necessary commands to halt his company at the second command; if at a halt the leading company stands fast. At the first command, the captain of each

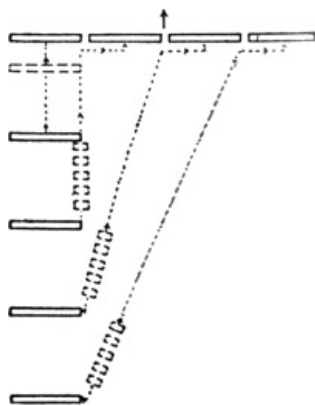

FROM COLUMN OF COMPANIES
TO LINE TO THE FRONT.

company in rear commands: **Squads right**, or **Right by squads**, and after the second command conducts his company by the most convenient route to its place in line, as described above.

Whether executed from column of squads or column of companies, each captain halts when opposite, or at the point, where the left of his company is to rest. (277) [Pg 95]

To Form Column of Companies Successively to the Right or Left

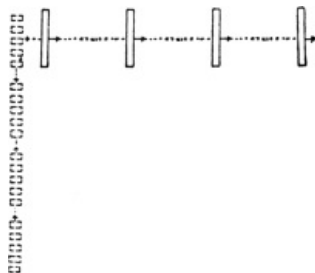

315. Being in column of squads: **1. Column of companies, first company, squads right (left), 2. MARCH.**

The leading company executes **squads right** and moves forward. The other companies move forward in column of squads and successively march in line the right on the same ground as the leading company and in such manner that the guide covers the guide of the preceding company. (278)

To Form Column of Squads Successively to the Right or Left

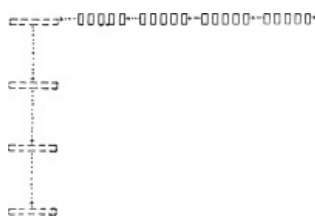

316. Being in column of companies ([Plate III](#), page 90): **1. Column of squads, first company, squads right (left), 2. MARCH.**

The leading company executes **squads right** and moves forward. The other companies move forward in column of companies and successively march in column of squads to the right on the same ground as the leading company. (279)

To Change Direction

317. Being in column of companies or close column. ([Plate III](#), page 90); **1. Column right (left), 2. MARCH.**

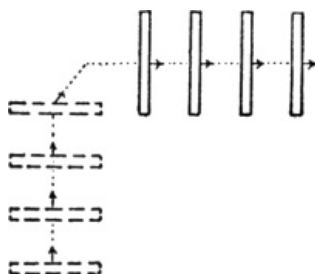

The captain of the first company commands: **Right turn.**

The leading company turns to the right on moving pivot, the captain adding: **1. Forward, 2. MARCH**, upon its completion.

The other companies march squarely up to the turning point; each changes direction by the same commands and means as the first and in such manner that the guide covers the guide of the preceding company. (280)

318. Being in line of companies or close line. ([Plate III](#), page 90): **1. Battalion right (left), 2. MARCH, 3. Battalion, 4. HALT.** [Pg 96]

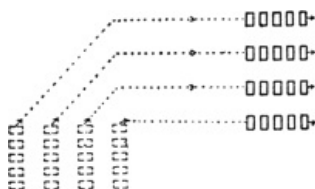

The right company changes direction to the right, as prescribed in [par. 224](#); the other companies are conducted by the shortest line to their places abreast of the first.

The fourth command is given when the right company has advanced the desired distance in the new direction; that company halts; the others halt successively upon arriving on the line. (281)

319. Being in column of squads, the battalion changes direction by the same commands and in the manner prescribed for the company, as explained in [par. 224](#). (282)

Mass Formations

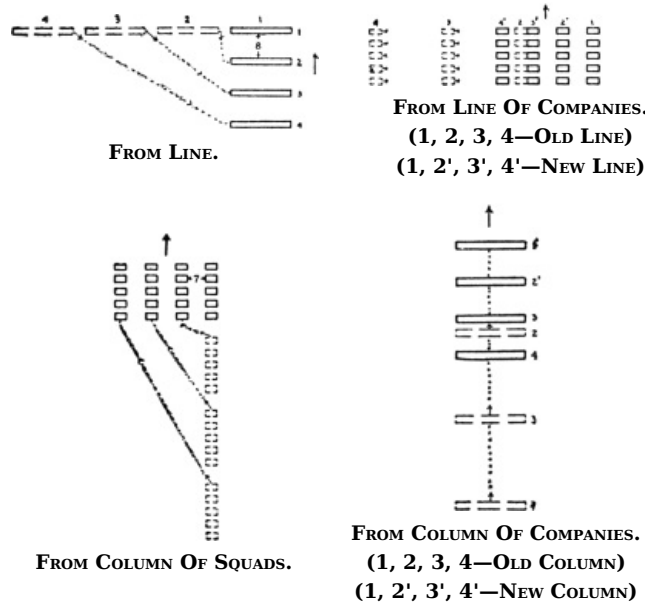

319a. Being in column of squads, to form a line of columns of companies or company subdivisions, facing in any desired direction, at any desired interval, on the right or left of the leading element of the battalion: **1. Line of companies (half companies, platoons), at (so many) paces, guide right (left), 2. MARCH, 3. Battalion, 4. HALT.**

The leading company (or subdivision) marches in the direction previously indicated by the major until the command halt is given and then halts. Each succeeding company (or subdivision) marches by the most direct route to its place at the prescribed intervals on the left (right) of the next preceding company (or subdivision), halting when it is abreast of the leading element of the battalion.

If the battalion be in any formation other than column of squads, the major indicates the desired direction to the leading element. The entire command forms column of squads and executes a movement in conformity with the principles indicated above. (282^{1/2})

320. Being in line, line of companies, or column of companies. ([Plate III](#), page 90): **1. Close on first (fourth) company, 2. MARCH.**

If at a halt, the indicated company stands fast; if marching, it is halted; each of the other companies is conducted toward it and is halted in proper order in close column. [Pg 97]

If the battalion is in line, companies form successively in rear of the indicated company; if in column of squads, companies in rear of the leading company form on the left of it.

In close column formed line on the first company, the left guides cover; formed on the fourth company, right guides cover. If formed on the leading company, the guide remains as before the formation. In close line, the guides are halted abreast of the guide of the leading company.

The battalion in column closes on the leading company only. (283)

(In closing from line of companies and in extending from close line, the companies other than the base one, may be moved either by the commands, (a) **1. Squads, right (left), 2. MARCH;** (b) **1. Right (left) oblique, 2. MARCH;** (c) **1. Forward, 2. MARCH;** (d) **1. Squads left (right) 2. MARCH;** (e) **1. Company, 2. HALT;** or, (a) **1. By the right (left) flank, 2. MARCH;** (b) **1. Company, 2. HALT;** (c) **1. Left (right), 2. FACE;** or if at a halt by the commands, (a) **1. Right (left), 2. FACE;** (b) **1. At Trail, 2. Forward, 3. MARCH;** (c) **1. Company, 2. HALT;** (d) **1. Left (right), 2. FACE.** In some commands it is customary to use one method while in other commands another is used. For the sake of uniformity all companies of a given command should use the same method.—Author.)

To Extend the Mass

321. Being in close column or in close line; **1. Extend on first (fourth) company, 2. MARCH.**

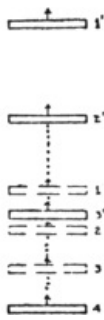

FROM CLOSE COLUMN..
(1, 2, 3, 4—OLD COLUMN)
(1', 2', 3', 4—NEW COLUMN)



FROM CLOSE LINE.

Being in close line: if at a halt, the indicated company stands fast; if marching, it halts; each of the other companies is conducted away from the indicated company and is halted in its proper order in line of companies.

Being in close column, the extension is made on the fourth company only. If marching, the leading company continues to march; companies in rear are halted and successively resume the march in time to follow at full distance. If at halt, the leading company marches; companies in rear successively march in time to follow at full distance.

Close column is not extended in double time. (See author's note, [par. 320.](#)) (284)

322. Being in close column: 1. Right (left) front into line, 2. MARCH. Executed as from column of companies, as explained in [par. 314.](#) (285)

323. Being in close column: 1. Column of squads, first (fourth) company, squads right (left), 2. MARCH.

The designated company marches in column of squads to the right. Each of the other companies executes the same movement in time to follow the preceding company in column. (286)

324. Being in close line: 1. Column of squads, first (fourth) company, forward, 2. MARCH.

The designated company moves forward. The other companies (halting if in march) successively take up the march and follow in column. (287)

Route Step and at Ease

325. The battalion marches in **route step** and **at ease** as prescribed in the School of the Company. (See [par. 233.](#)) When marching in column of companies or platoons, the guides maintain the trace and distance.

In route marches the major marches at the head of the column; when necessary, the file closers may be directed to march at the head and rear of their companies. (288)

Assembly

326. The battalion being wholly or partially deployed, or the companies being separated: **1. Assemble, 2. MARCH.**

The major places himself opposite to or designates the element or point on which the battalion is to assemble. Companies are assembled, as explained in [par. 248,](#) and marched to the indicated point. As the companies arrive the major or adjutant indicates the formation to be taken. (289)

COMBAT PRINCIPLES

Orders

327. The following references to orders are applicable to attack or defense: (290)

328. Use of prescribed commands; "tactical orders," "orders" and "commands." In extended order, the company is the largest unit to execute movements by prescribed commands or means. The major, assembling his captains if practicable, directs the disposition of the battalion by means of **tactical orders.** He controls its subsequent movements by such **orders** or **commands** as are suitable to the occasion. (291)

329. Major's order making disposition of battalion for combat; base company in attack. In every disposition of the battalion for combat the major's order should give subordinates sufficient information of the enemy, of the position of supporting and neighboring troops, and of the object sought to enable them to conform intelligently to the general plan.

The order should then designate the companies which are to constitute the **firing line** and those which are to constitute the **support.** In attack, it should designate the direction or the objective, the order and front of the companies on the firing line, and should designate the right or left

company as base company. In defense, it should describe the front of each company and, if necessary, the sector to be observed by each, as prescribed in [281](#)-284. (292)

330. Reconnaissance and protection of flanks. When the battalion is operating alone, the major provides for the reconnaissance and protection of his flanks; if part of a larger force, the major makes similar provisions, when necessary, without orders from higher authority, unless such authority has specifically directed other suitable reconnaissance and protection. (293)

331. Issue of extra ammunition when battalion is deployed. When the battalion is deployed upon the initiative of the major, he will indicate whether extra ammunition shall be issued; if deployed in pursuance of orders of higher authority, the major will cause the issue of extra ammunition, unless such authority has given directions to the contrary. (For ammunition supply see [pars. 569](#)-575.) (294)

[Pg 99]

Deployment

(See [pars. 456](#)-462; [463](#)-466.)

332. The following principles of deployment are applicable to attack or defense. (295)

333. Avoiding premature deployment. A premature deployment involves a long, disorganizing and fatiguing advance of the skirmish line, and should be avoided. A greater evil is to be caught by heavy fire when in dense column or other close order formation; hence advantage should be taken of cover in order to retain the battalion in close order formation until exposure to heavy hostile fire may reasonably be anticipated. (296)

334. Depth of deployment and density of firing line; companies and detachments conducted to their places by their commanders. The major regulates the depth of the deployment and the extent and density of the firing line, subject to such restrictions as a senior may have imposed.

Companies or designated subdivisions and detachments are conducted by their commanders in such manner as best to accomplish the mission assigned to them under the major's orders. Companies designated for the firing line march independently to the place of deployment, form skirmish line, and take up the advance. They conform, in general, to the base company, as prescribed in [Par. 329](#). (297)

335. Division of battalion into firing line and support. The commander of a battalion, whether it is operating alone or as part of a larger force, should hold a part of his command out of the **firing line**. By the judicious use of this force, the major can exert an influence not otherwise possible over his firing line and can control, within reasonable limits, an action once begun. So, if his battalion be assigned to the **firing line**, the major will cause one, two, or three companies to be deployed on the firing line, retaining the remaining companies or company as a support for that firing line. The division of the battalion into firing line and support will depend upon the front to be covered and the nature and anticipated severity of the action. (298)

336. Size of support. If the battalion be part of a larger command, the number of companies in the firing line will generally be determinable from the regimental commander's order; the remainder constitutes the support, as prescribed in [par. 335](#). If the battalion is acting alone, the support must be strong enough to maintain the original fire power of the firing line, to protect the flanks, and to perform the functions of a reserve, whatever be the issue of the action, as explained in [par. 445](#). (299)

337. Position of support. If the battalion is operating alone, the support may, according to circumstances, be held in one or two bodies and placed behind the center, or one or both flanks of the firing line, or echeloned beyond a flank. If the battalion is part of a larger force, the support is generally held in one body. (300)

[Pg 100]

338. Distance between firing line and support. The distance between the firing line and the supporting group or groups will vary between wide limits; it should be as short as the necessity for protection from heavy losses will permit. When cover is available, the support should be as close as 50 to 100 yards; when such cover is not available, it should not be closer than 300 yards. It may be as far as 500 yards in rear if good cover is there obtainable and is not obtainable at a lesser distance. (301)

339. Placing entire battalion or regiment in firing line at beginning. In exceptional cases, as in a meeting engagement, it may be necessary to place an entire battalion or regiment in the firing line at the initial deployment, the support being furnished by other troops. Such deployment causes the early mingling of the larger units, thus rendering leadership and control extremely difficult. The necessity for such deployment will increase with the inefficiency of the commander and of the service of information. (302)

Fire

340. Major apportionments target. Fire direction and fire control are functions of company and platoon commanders, as laid down in [pars. 285-290](#). The major makes the primary apportionment of the target—in defense, by assigning sectors of fire, in attack, by assigning the objective. In the latter case each company in the firing line takes as its target that part of the general objective which lies in its front. (303)

341. Major indicates where or when fire fight begins. The major should indicate the point or time at which the fire fight is to open. He may do this in his order for deployment or he may follow the firing line close enough to do so at the proper time. If it be impracticable for him to do either, the senior officer with the firing line, in each battalion, selects the time for opening fire. (304)

Attack

(See [pars. 456-502](#).)

342. Battalion the attack unit. The battalion is the **attack unit**, whether operating alone or as part of a larger unit. (305)

343. Advance of battalion acting as one of several in firing line. If his battalion be one of several in the firing line, the major, in executing his part of the attack, pushes his battalion forward as vigorously as possible within the front, or section, assigned to it. The great degree of independence allowed to him as to details demands, in turn, the exercise of good judgment on his part. Better leadership, better troops, and more favorable terrain enable one battalion to advance more rapidly in attack than another less fortunate, and such a battalion will insure the further advance of the others. The leading battalion should not, however, become isolated; isolation may lead to its destruction. (306)

[Pg 101]

344. Close in on enemy as much as possible before opening fire. The deployment having been made, the firing line advances without firing. The predominant idea must be to close with the enemy as soon as possible without ruinous losses. The limited supply of ammunition and the uncertainty of resupply, the necessity for securing fire superiority in order to advance within the shorter ranges, and the impossibility of accomplishing this at ineffective ranges, make it imperative that fire be not opened as long as the advance can be continued without demoralizing losses. The attack which halts to open fire at extreme range (over 1,200 yards) is not likely ever to reach its destination. Every effort should be made, by using cover or inconspicuous formations, or by advancing the firing line as a whole, to arrive within 800 yards of the enemy before opening fire. (For expenditure of ammunition see [pars. 432-433](#); for advancing the attack see [par. 467](#).) (307)

345. Fire to be directed against the hostile infantry. Except when the enemy's artillery is able to effect an unusual concentration of fire, its fire upon deployed infantry causes losses which are unimportant when compared with those inflicted by his infantry; hence the attacking infantry should proceed to a position as described above, and from which an effective fire can be directed against the hostile infantry with a view to obtaining fire superiority. The effectiveness of the enemy's fire must be reduced so as to permit further advance. The more effective the fire to which the enemy is subjected the less effective will be his fire. (308)

346. The further advance of the firing line; size of rushing units. Occasionally the fire of adjacent battalions, or of infantry employing fire of position, as explained in [par. 438](#), or of supporting artillery, as explained in [pars. 434-438](#), will permit the further advance of the entire firing line from this point, but it will generally be necessary to advance by rushes, as laid down in [par. 259](#), of fractions of the line.

The fraction making the rush should be as large as the hostile fire and the necessity for maintaining fire superiority will permit. Depending upon circumstances, the strength of the fraction may vary from a company to a few men.

The advance is made as rapidly as possible without losing fire superiority. The smaller the fraction which rushes, the greater the number of rifles which continue to fire upon the enemy. On the other hand, the smaller the fraction which rushes the slower will be the progress of the attack. (309)

347. Size of rushing units. Enough rifles must continue in action to insure the success of each rush. Frequently the successive advances of the firing line must be effected by rushes of fractions of decreased size; that is, advances by rushes may first be made by company, later by half company or platoon, and finally by squads or files; but no **subsequent opportunity to increase** the rate of advance, such as better cover or a decrease of the hostile fire, should be overlooked. (310)

348. The rush begun by a flank unit. Whenever possible, the rush is begun by a flank fraction of the firing line. In the absence of express directions from the major, each captain of a flank company determines when an advance by rushes ([par. 222](#)) shall be attempted. A flank company which inaugurates an advance by rushes becomes the base company, if not already the base. An

[Pg 102]

advance by rushes having been inaugurated on one flank, the remainder of the firing line conforms; fractions rush successively from that flank and halt on the line established by the initial rush.

The fractions need not be uniform in size; each captain indicates how his company shall rush, having due regard to the ground and the state of the fire fight. (311)

349. Fractions to advance under covering fire. A fraction about to rush is sent forward when the remainder of the line is firing vigorously; otherwise the chief advantage of this method of advancing is lost.

The length of the rush will vary from 30 to 80 yards, depending upon the existence of cover, positions for firing, and the hostile fire. (312)

350. Subsequent advances. When the entire firing line of the battalion has advanced to the new line, fresh opportunities to advance are sought as before. (313)

351. Prearranged methods of advancing by rushes prohibited. Two identical situations will never confront the battalion; hence at drill it is prohibited to arrange the details of an advance before the preceding one has been concluded, or to employ a fixed or prearranged method of advancing by rushes. (314)

352. Post of the major. The major posts himself so as best to direct the reënforcing of the firing line from the support. When all or nearly all of the support has been absorbed by the firing line, he joins, and takes full charge of, the latter. (315)

353. Size of reënforcements. The reënforcing of the firing line by driblets of a squad or a few men has no appreciable effect. The firing line requires either reënforcement or a strong one. Generally one or two platoons will be sent forward under cover of a heavy fire of the firing line. (316)

354. Two methods of reënforcing the firing line. To facilitate control and to provide intervals in which reënforcements may be placed, the companies in the firing line should be kept closed in on their centers as they become depleted by casualties during the advance.

When this is impracticable reënforcements must mingle with and thicken the firing line. In battle the latter method will be the rule rather than the exception, and to familiarize the men with such conditions the combat exercises of the battalion should include both methods of reënforcing. Occasionally, to provide the necessary intervals for reënforcing by either of these methods, the firing line should be thinned by causing men to drop out and simulate losses during the various advances. Under ordinary conditions the depletion of the firing line for this purpose will be from one-fifth to one-half of its strength. (317)

355. Fixing bayonets. The major or senior officer in the firing line determines when bayonets shall be fixed and gives the proper command or signal. It is repeated by all parts of the firing line. Each man who was in the front rank prior to deployment, as soon as he recognizes the command or signal, suspends firing, quickly fixes his bayonet, and immediately resumes firing; after which the other men suspend firing, fix bayonets, and immediately resume firing. The support also fixes bayonets. The concerted fixing of the bayonet by the firing line at drill does not simulate battle conditions and should not be required. It is essential that there be no marked pause in the firing. Bayonets will be fixed generally before or during the last, or second last, advance preceding the charge. (318)

[Pg 103]

356. The charge. Subject to orders from higher authority, the major determines the point from which the charge is to be made. (See [Pars. 478-489](#) regarding the charge.) The firing line having arrived at that point and being in readiness, the major causes the **charge** to be sounded. The signal is repeated by the musicians of all parts of the line. The company officers lead the charge. The skirmishers spring forward shouting, run with bayonets at charge, and close with the enemy.

The further conduct of the charging troops will depend upon circumstances; they may halt and engage in bayonet combat or in pursuing fire, as explained in [par. 486](#); they may advance a short distance to obtain a field of fire or to drive the enemy from the vicinity; they may assemble or reorganize, etc. If the enemy vacates his position every effort should be made to open fire at once on the retreating mass, reorganization of the attacking troops being of secondary importance to the infliction of further losses upon the enemy and to the increase of his confusion, as set forth in [pars. 490-494](#). In combat exercises the major will assume a situation and terminate the assault accordingly. (319)

Defense

357. Tactical unit best suited to defensive action. In defense, as in attack, the battalion is the tactical unit best suited to independent assignment. Defensive positions are usually divided into sections and a battalion assigned to each. (320)

358. Trenches. The major locates such fire, communicating, and cover trenches and obstacles as are to be constructed. He assigns companies to construct them and details the troops to occupy them. (See "Field Fortifications," Chapter XVI, Part III.) (321)

359. Reënforcement of firing line. The major reënforces the firing line in accordance with the principles applicable to and explained in connection with, the attack, in [pars. 352-354](#), maintaining no more rifles in the firing line than are necessary to prevent the enemy's advance. (322)

360. Opening fire. The supply of ammunition being usually ample, fire is opened as soon as it is possible to break up the enemy's formation, stop his advance or inflict material loss, but this rule must be modified to suit the ammunition supply. (323)

361. Fixing bayonets. The major causes the firing line and support to fix bayonets when an assault by the enemy is imminent. Captains direct this to be done if they are not in communication with the major and the measure is deemed advisable.

Fire alone will not stop a determined, skillfully conducted attack. The defender must have equal tenacity; if he can stay in his trench or position and cross bayonets, he will at least have neutralized the hostile first line, and the combat will be decided by reserves. (324)

362. Support to cover withdrawal. If ordered or compelled to withdraw under hostile infantry fire or in the presence of hostile infantry, the support will be posted so as to cover the retirement of the firing line (325)

[Pg 104]

363. Support in case of battalion acting alone. When the battalion is operating alone, the support must be strong and must be fed sparingly into the firing line, especially if a counter-attack is planned. Opportunities for counter-attack should be sought at all times, as explained in [pars. 525-530](#). (326)

COMBAT

INTRODUCTION

364. Scope of subject of combat tactics in this book. Part II of these regulations treats only of the basic principles of combat tactics as applied to infantry and to the special units, such as machine guns and mounted scouts, which form a part of infantry regiments and battalions.

The combat tactics of the arms combined are considered in Field Service Regulations. (350)

365. Demands of modern combat upon infantry; complicated maneuvers impracticable; success dependent upon leadership, etc. Modern combat demands the highest order of training, discipline, leadership, and morale on the part of the infantry. Complicated maneuvers are impracticable; efficient leadership and a determination to win by simple and direct methods must be depended upon for success. (351)

366. Duties and quality of infantry. The duties of infantry are many and difficult. All infantry must be fit to cope with all conditions that may arise. Modern war requires but one kind of infantry—good infantry. (352)

367. Offensive necessary for decisive results; use of ground, fire efficiency, etc.; local success. The infantry must take the offensive to gain decisive results. Both sides are therefore likely to attempt it, though not necessary at the same time or in the same part of a long battle line.

In the local combats which make up the general battle the better endurance, use of ground, fire efficiency, discipline, and training will win. It is the duty of the infantry to win the local successes which enable the commanding general to win the battle. (356)

368. Requisites of infantry; trained to bear heaviest burdens; good infantry can defeat vastly superior infantry of poor quality. The infantry must have the tenacity to hold every advantage gained, the individual and collective discipline and skill needed to master the enemy's fire, the determination to close with the enemy in attack, and to meet him with the bayonet in defense. Infantry must be trained to bear the heaviest burdens and losses, both of combat and march.

Good infantry can defeat an enemy greatly superior in numbers, but lacking in training, discipline, leadership, and morale. (354)

369. Fixed forms and instructions covering all cases impossible; study and practice necessary; purposes of practical and theoretical instruction. It is impossible to establish fixed forms or to give general instructions that will cover all cases. Officers and noncommissioned officers must be so trained that they can apply suitable means and methods to each case as it arises. Study and practice are necessary to acquire proper facility in this respect. Theoretical instruction can not replace practical instruction; the former supplies correct ideas

[Pg 105]

and gives to practical work an interest, purpose, and definiteness not otherwise obtainable. (355)

370. Exercises in extended order to be in nature of combat exercises; all combat exercises to be conducted under assumed tactical situations. After the mechanism of extended order drill has been learned with precision in the company, every exercise should be, as far as practicable, in the nature of a maneuver (combat exercise) against an **imaginary, outlined, or represented** enemy.

Company extended order drill may be conducted without reference to a tactical situation, but a combat exercise, whatever may be the size of the unit employed, should be conducted under an assumed tactical situation. (356)

371. Effective method of conducting combat exercises. An effective method of conducting a combat exercise is to outline the enemy with a few men equipped with flags. The umpire or inspector states the situation, and the commander leads his troops with due regard to the assumptions made.

Changes in situation, the results of reconnaissance, the character of artillery fire, etc., are made known to the commander when necessary by the umpire or inspector, who, in order to observe and influence the conduct of the exercise, remains in rear of the firing line. From this position he indicates, with the aid of prearranged signals, the character of the fire and movements of the hostile infantry. These signals are intended for the men outlining the enemy. These men repeat the signals; all officers and men engaged in the exercise and in sight of the outlined enemy are thus informed of the enemy's action, and the exercise is conducted accordingly.

Assistant umpires, about one for each company in the firing line, may assist in indicating hostile fire and movements and in observing the conduct of the exercise.

An outlined enemy may be made to attack or defend.

Situations should be simple and natural. During or after the exercise the umpire or inspector should call attention to any improper movements or incorrect methods of execution. He will prohibit all movements of troops or individuals that would be impossible if the enemy were real. The slow progress of events to be expected on the battlefield can hardly be simulated, but the umpire or inspector will prevent undue haste and will attempt to enforce a reasonably slow rate of progress.

The same exercise should not be repeated over the same ground and under the same situation. Such repetitions lead to the adoption of a fixed mode of attack or defense and develop mere drill masters. Fixed or prearranged systems are prohibited. (357)

LEADERSHIP

[Pg 106]

General Considerations

372. What constitutes art of leadership. The art of leadership consists of applying sound tactical principles to concrete cases on the battlefield.

Self-reliance, initiative, aggressiveness, and a conception of team-work are the fundamental characteristics of successful leadership. (358)

373. Basis of success; adherence to original plan. A correct grasp of the situation and a definite plan of action form the soundest basis for a successful combat.

A good plan once adopted and put into execution should not be abandoned unless it becomes clear that it can not succeed. Afterthoughts are dangerous, except as they aid in the execution of details in the original plans. (359)

374. Avoid combats offering no chance of valuable results. Combats that do not promise success or some real advantage to the general issue should be avoided; they cause unnecessary losses, impair the morale of one's own troops, and raise that of the enemy. (360)

375. Avoid complicated maneuvers. Complicated maneuvers are not likely to succeed in war. All plans and the methods adopted for carrying them into effect must be simple and direct. (361)

376. Order and cohesion necessary. Order and cohesion must be maintained within the units if success is to be expected. (362)

377. Officers to be true leaders. Officers must show themselves to be true leaders. They must act in accordance with the spirit of their orders and must require of their troops the strictest discipline on the field of battle. (363)

378. Units not to be broken up. The best results are obtained when leaders know the capacity and traits of those whom they command; hence in making detachments units should not be

broken up, and a deployment that would cause an intermingling of the larger units in the firing line should be avoided. (364)

379. Leading deployed troops difficult; necessity for training, discipline and close order. Leading is difficult when troops are deployed. A high degree of training and discipline and the use of close order formations to the fullest extent possible are therefore required. (365)

380. Avoidance of unnecessary hardship; limit of endurance exacted when necessary. In order to lighten the severe physical strain inseparable from infantry service in campaign, constant efforts must be made to spare the troops unnecessary hardship and fatigue; but when necessity arises, the limit of endurance must be exacted. (366)

381. Fighting troops not to carry back wounded. When officers or men belonging to fighting troops leave their proper places to carry back, or to care for, wounded during the progress of the action, they are guilty of skulking. This offense must be repressed with the utmost vigor. (367)

382. Complete equipment usually carried into action. The complete equipment of the soldier is carried into action unless the weather or the physical condition of the men renders such measure a severe hardship. In any event, **only the pack^[4] will be laid aside.** The determination of this question rests with the regimental commander. The complete equipment affords to men lying prone considerable protection against shrapnel. (368)

[Pg 107]

383. Post of commander; use of reserve in case of victory; when firing line is controlled by commander. The post of the commander must be such as will enable him to observe the progress of events and to communicate his orders. Subordinate commanders, in addition, must be in position to transmit the orders of superiors.

Before entering an action, the commander should be as far to the front as possible in order that he personally may see the situation, order the deployment, and begin the action strictly in accordance with his own wishes.

During the action, he must, as a rule, leave to the local leaders the detailed conduct of the firing line, posting himself either with his own reserve or in such a position that he is in constant, direct, and easy communication with it.

A commander takes full and direct charge of his firing line only when the line has absorbed his whole command.

When their troops are victorious, all commanders should press forward in order to clinch the advantage gained and to use their reserves to the best advantage. (369)

384. Latitude allowed subordinates. The latitude allowed to officers is in direct proportion to the size of their commands. Each should see to the general execution of his task, leaving to the proper subordinates the supervision of details, and interfering only when mistakes are made that threaten to seriously prejudice the general plan. (370)

Teamwork

385. Latitude allowed subordinates; success depends on coördination of subordinates. The comparatively wide fronts of deployed units increase the difficulties of control. Subordinates must therefore be given great latitude in the execution of their tasks. The success of the whole depends largely upon how well each subordinate coördinates his work with the general plan.

A great responsibility is necessarily thrown upon subordinates, but responsibility stimulates the right kind of an officer. (371)

386. Initiative of subordinates; general plan to be furthered. In a given situation it is far better **to do any intelligent thing** consistent with the aggressive execution of the general plan, than to search hesitatingly for the ideal. This is the true rule of conduct for subordinates who are required to act upon their own initiative.

A subordinate who is reasonably sure that his intended action is such as would be ordered by the commander, were the latter present and in possession of the facts, has enough encouragement to go ahead confidently. He must possess the loyalty to carry out the plans of his superior and the keenness to recognize and to seize opportunities to further the general plan. (372)

387. But one supreme will in a battle; subordinates to coöperate. Independence must not become license. Regardless of the number of subordinates who are apparently supreme in their own restricted spheres, there is but one battle and but one supreme will to which all must conform.

[Pg 108]

Every subordinate must therefore work for the general result. He does all in his power to insure coöperation between the subdivisions under his command. He transmits important information to adjoining units or to superiors in rear and, with the assistance of information received, keeps

himself and his subordinates duly posted as to the situation. (373)

388. Deviation from orders. When circumstances render it impracticable to consult the authority issuing an order, officers should not hesitate to vary from such order when it is clearly based upon an incorrect view of the situation, is impossible of execution, or has been rendered impracticable on account of changes which have occurred since its promulgation. In the application of this rule the responsibility for mistakes rests upon the subordinate, but unwillingness to assume responsibility on proper occasions is indicative of weakness.

Superiors should be careful not to censure an apparent disobedience where the act was done in the proper spirit and to advance the general plan. (374)

389. Intermingling of units; duties of officers and guides. When the men of two or more units intermingle in the firing line, all officers and men submit at once to the senior. Officers and platoon guides seek to fill vacancies caused by casualties. Each seizes any opportunity to exercise the functions consistent with his grade, and all assist in the maintenance of order and control.

Every lull in the action should be utilized for as complete restoration of order in the firing line as the ground or other conditions permit. (375)

390. Separated officers and noncommissioned officers placing themselves under nearest higher commander. Any officer or noncommissioned officer who becomes separated from his proper unit and can not rejoin must at once place himself and his command at the disposal of the nearest higher commander. (376)

Anyone having completed an assigned task must seek to rejoin his proper command. Failing in this, he should join the nearest troops engaged with the enemy.

391. Duty of separated soldiers. Soldiers are taught the necessity of remaining with their companies, but those who become detached must join the nearest company and serve with it until the battle is over or reorganization is ordered. (377)

Orders

392. Orders for deployment; combat orders of divisions and brigades usually written. Commands are deployed and enter the combat by the orders of the commander to the subordinate commanders.

The initial combat orders of the division are almost invariably written; those of the brigade are generally so. The written order is preferable and is used whenever time permits.

[Pg 109]

If time permits, subsequent orders are likewise written, either as field orders or messages. (378)

393. Combat orders of regiments and smaller units; verbal messages. The initial combat orders of regiments and smaller units are given verbally. For this purpose the subordinates for whom the orders are intended are assembled, if practicable, at a place from which the situation and plan can be explained.

Subsequent orders are verbal or in the form of verbal or written messages. Verbal messages should not be used unless they are short and unmistakable. (379)

394. Initial combat orders; personal reconnaissance. The initial combat order of any commander or subordinate is based upon his definite plan for executing the task confronting him.

Whenever possible the formation of the plan is preceded by a personal reconnaissance of the terrain and a careful consideration of all information of the enemy. (380)

395. Composition of combat orders. The combat order gives such information of the enemy and of neighboring or supporting friendly troops as will enable subordinates to understand the situation.

The general plan of action is stated in brief terms, but enough of the commander's intentions is divulged to guide the subsequent actions of the subordinates.

Clear and concise instructions are given as to the action to be taken in the combat by each part of the command. In this way the commander assigns tasks, fronts, objectives, sectors or areas, etc., in accordance with his plan. If the terms employed convey definite ideas and leave no loopholes, the conduct of subordinates will generally be correspondingly satisfactory.

Such miscellaneous matter relating to special troops, trains, ammunition, and future movements of the commander is added as concerns the combat itself.

Combat orders should prescribe communication, reconnaissance, flank protection, etc., when some special disposition is desired or when an omission on the part of a subordinate may reasonably be feared. (381)

396. Encroaching upon functions of subordinates prohibited; orders to be definite. When issuing orders, a commander should indicate clearly **what** is to be done by each subordinate, but not **how** it is to be done. He should not encroach upon the functions of a subordinate by prescribing details of execution unless he has good reason to doubt the ability or judgment of the subordinate, and cannot substitute another.

Although general in its terms, an order must be definite and must be the expression of a fixed decision. Ambiguity or vagueness indicates either a vacillation or the inability to formulate orders. (382)

397. Orders generally given subordinates through their immediate superiors. Usually the orders of a commander are intended for, and are given to, the commanders of the next lower units, but in an emergency commander should not hesitate to give orders directly to any subordinate. In such case he should promptly inform the intermediate commander concerned. (383)

[Pg 110]

Communication

398. Communication, how maintained. Communication is maintained by means of staff officers, messengers, relay systems, connecting files, visual signals, telegraph, or telephone. (384)

399. Lines of communication established by signal corps. The signal corps troops of the division establish lines of information from division to brigade headquarters. The further extension of lines of information in combat by signal troops is exceptional. (385)

400. Lines of communication established by regiment; orderlies carry signal flags. Each regiment, employing its own personnel, is responsible for the maintenance of communication from the colonel back to the brigade and forward to the battalions. For this purpose the regiment uses the various means which may be furnished it. The staff and orderlies, regimental and battalion, are practiced in the use of these means and in messenger service. Orderlies carry signal flags. (386)

401. Communication between firing line and major or colonel; company musicians carry signal flags. Connection between the firing line and the major or colonel is practically limited to the prescribed flag, arm, and bugle signals. Other means can only be supplemental. Company musicians carry company flags and are practiced in signaling. (387)

402. Communication by artillery with firing line by means of staff officers or through agents. The artillery generally communicates with the firing line by means of its own staff officers or through an agent who accompanies some unit in or near the front. The infantry keeps him informed as to the situation and affords any reasonable assistance. When the infantry is dependent upon the artillery for fire support, perfect coördination through this representative is of great importance. (388)

COMBAT RECONNAISSANCE

403. Importance of combat reconnaissance; avoidance of deployment on wrong lines. Combat reconnaissance is of vital importance and must not be neglected. By proper preliminary reconnaissance, deployments on wrong lines, or in a wrong direction, and surprises may generally be prevented. (389)

404. Protection of troops by proper reconnaissance. Troops deployed and under fire can not change front, and thus they suffer greatly when enfiladed. Troops in close order formation may suffer heavy losses in a short time if subjected to hostile fire. In both formations troops must be protected by proper reconnaissance and warning. (390)

405. Difficulty of reconnaissance depends on extent of enemy's screen; strength of reconnoitering parties. The difficulty of reconnaissance increases in proportion to the measures adopted by the enemy to screen himself.

The strength of the reconnoitering party is determined by the character of the information desired and the nature of the hostile screen. In exceptional cases as much as a battalion may be necessary in order to break through the hostile screen and enable the commander or officer in charge to reconnoiter in person.

[Pg 111]

A large reconnoitering party is conducted so as to open the way for small patrols, to serve as a supporting force or rallying point for them, and to receive and transmit information. Such parties maintain signal communication with the main body if practicable. (391)

406. Each separate column to protect itself by reconnaissance. Each separate column moving forward to deploy must reconnoiter to its front and flank and keep in touch with adjoining columns. The extent of the reconnaissance to the flank depends upon the isolation of the

columns. (392)

407. Reconnaissance before attacking. Before an attack a reconnaissance must be made to determine the enemy's position, the location of his flanks, the character of the terrain, the nature of the hostile field works, etc., in order to prevent premature deployment and the resulting fatigue and loss of time.

It will frequently be necessary to send forward a thin skirmish line in order to induce the enemy to open fire and reveal his position. (393)

408. Extent of reconnaissance. It will frequently be impossible to obtain satisfactory information until after the action has begun. The delay that may be warranted for the purpose of reconnaissance depends upon the nature of the attack and the necessity for promptness. For example, in a meeting engagement, and sometimes in a holding attack, the reconnaissance may have to be hasty and superficial, whereas in an attack against an enemy carefully prepared for defense there will generally be both time and necessity for thorough reconnaissance. (394)

409. Reconnaissance in defense. In defense, reconnaissance must be kept up to determine the enemy's line of advance, to ascertain his dispositions, to prevent his reconnaissance, etc.

Patrols or parties posted to prevent hostile reconnaissance should relieve the main body of the necessity of betraying its position by firing on small bodies of the enemy. (395)

410. Duration of reconnaissance; protection of flanks. Reconnaissance continues throughout the action.

A firing or skirmish line can take care of its front, but its flanks are especially vulnerable to modern firearms. The moral effect of flanking fire is as great as the physical effect. Hence, combat patrols to give warning or covering detachments to give security are indispensable on exposed flanks. This is equally true in attack or defense. (396)

411. Responsibility of infantry commanders for reconnaissance; surprise unpardonable. The fact that cavalry patrols are known to be posted in a certain direction does not relieve infantry commanders of the responsibility for reconnaissance and security.

To be surprised by an enemy at short range is an unpardonable offense. (397)

412. Commander of flank battalion responsible for security of his flank. The commander of a battalion on a flank of a general line invariably provides for the necessary reconnaissance and security on that flank unless higher authority has specifically ordered it. In any event, he sends out combat patrols as needed.

[Pg 112]

Where his battalion is on a flank of one section of the line and a considerable interval lies between his battalion and the next section, he makes similar provision. (398)

413. Patrols established by battalion commanders. Battalion commanders in the first line establish patrols to observe and report the progress or conduct of adjoining troops when these can not be seen. (399)

FIRE SUPERIORITY

PURPOSE AND NATURE

(See [par. 427](#))

414. Success in battle dependent upon fire superiority. In a decisive battle success depends on gaining and maintaining fire superiority. Every effort must be made to gain it early and then to keep it.

Attacking troops must first gain fire superiority in order to reach the hostile position. Over open ground attack is possible only when the attacking force has a decided fire superiority. With such superiority the attack is not only possible, but success is probable and without ruinous losses.

Defending troops can prevent a charge only when they can master the enemy's fire and inflict heavy losses upon him. (400)

415. Volume and accuracy necessary to obtain fire superiority. To obtain fire superiority it is necessary to produce a heavy volume of accurate fire. Every increase in the effectiveness of the fire means a corresponding decrease in the effectiveness of the enemy's fire.

The volume and accuracy of fire will depend upon several considerations:

(a) The number of rifles employed. On a given front the greatest volume of fire is produced by a firing line having only sufficient intervals between men to permit the free use of their rifles. The maximum density of a firing line is therefore about one man per yard of front.

(b) The **rate** of fire affects its volume; an excessive rate reduces its accuracy.

(c) The character of the target influences both volume and accuracy. Larger dimensions, greater visibility, and shorter range increase the rate of fire; greater density increases **the effect**.

(d) Training and discipline have an important bearing on the rate or volume of fire, but their greatest influence is upon accuracy.

The firing efficiency of troops is reduced by fatigue and adverse psychological influences.

(e) Fire direction and control improve collective accuracy. The importance of fire direction increases rapidly with the range. Control exerts a powerful influence at all ranges. (401)

FIRE DIRECTION AND CONTROL

[Pg 113]

Opening Fire

416. Long range fire, when effective. Beyond effective ranges important results can be expected only when the target is large and distinct and much ammunition is used.

Long range fire is permissible in pursuit on account of the moral effect of any fire under the circumstances. At other times such fire is of doubtful value. (402)

417. Opening fire in attack. In attack, the desire to open fire when losses are first felt must be repressed. Considerations of time, target, ammunition, and morale make it imperative that the attack withhold its fire and press forward to a first firing position close to the enemy. The attacker's target will be smaller and fainter than the one he presents to the enemy. (403)

418. Opening fire in defense. In defense, more ammunition is available, ranges are more easily determined, and the enemy usually presents a larger target. The defender may therefore open fire and expect results at longer ranges than the attacker, and particularly if the defenders intend a delaying action only.

If the enemy has a powerful artillery, it will often be best for the defending infantry to withhold its fire until the enemy offers a specially favorable target. Vigorous and well-directed bursts of fire are then employed. The troops should therefore be given as much artificial protection as time and means permit, and at an agreed signal expose themselves as much as necessary and open fire. (404)

419. Opening fire in unexpected, close encounters. In unexpected, close encounters a great advantage accrues to the side which first opens rapid and accurate fire with battle sight. (405)

Use of Ground

420. Requisites of ground for cover. The position of the firers must afford a suitable field of fire.

The ground should permit constant observation of the enemy, and yet enable the men to secure some cover when not actually firing.

Troops whose target is for the moment hidden by unfavorable ground, either move forward to better ground or seek to execute cross fire on another target. (406)

421. Skillful use of ground reduces visibility. The likelihood of a target being hit depends to a great extent upon its visibility. By skillful use of ground, a firing line may reduce its visibility without loss of fire power. Sky lines are particularly to be avoided. (407)

Choice of Target

422. Target to be chosen. The target chosen should be the hostile troops most dangerous to the firers. These will usually be the nearest hostile infantry. When no target is specially dangerous, that one should be chosen which promises the most hits. (408)

423. Target not to be changed except for good reason. Frequent changes of target impair the fire effect. Random changes to small, unimportant targets impair fire discipline and accomplish nothing. Attention should be confined to the main target until substantial reason for change is apparent. (409)

[Pg 114]

424. Flanking fire to be delivered when opportunity offers. An opportunity to deliver

flanking fire, especially against artillery protected in front by shields, is an example warranting change of target and should never be overlooked. Such fire demoralizes the troops subjected to it, even if the losses inflicted are small. In this manner a relatively small number of rifles can produce important results. (410)

The Range

425. Importance of correct sight setting. Beyond close range, the correct setting of the rear sight is of primary importance, provided the troops are trained and well in hand. The necessity for correct sight setting increases rapidly with the range. Its importance decreases as the quality of the troops decrease, for the error in sight setting, except possibly at very long ranges, becomes unimportant when compared with the error in holding and aiming. (411)

426. Determination of ranges. In attack, distances must usually be estimated and corrections made as errors are observed. Mechanical range finders and ranging volleys are practicable at times.

In defense, it is generally practicable to measure more accurately the distances to visible objects and to keep a record of them for future use. (412)

Distribution of Fire and Target

427. Purpose of fire superiority; distribution of fire and target. The purpose of fire superiority is to get hits whenever possible, but at all events to keep down the enemy's fire and render it harmless. To accomplish this the target must be covered with fire throughout its whole extent. Troops who are not fired upon will fire with nearly peacetime accuracy.

The target is roughly divided and a part is assigned to each unit. No part of the target is neglected. In attack, by a system of overlapping in assigning targets to platoons, the entire hostile line can be kept under fire even during a rush. ([Pars. 400-401.](#)) (413)

Observation

428. Observation of target. The correctness of the sight setting and the distribution of fire over the target can be verified only by careful observation of the target, the adjacent ground, and the effect upon the enemy. (414)

429. Observation determines whether fire fight is being properly conducted. Observation only can determine whether the fire fight is being properly conducted. If the enemy's fire is losing in accuracy and effect, the observer realizes that his side is gaining superiority. If the enemy's fire remains or becomes effective and persistent, he realizes that corrective measures are necessary to increase either volume or accuracy, or both. (415)

[Pg 115]

Discipline

430. What discipline accomplishes. Discipline makes good direction and control possible and is the distinguishing mark of trained troops. (416)

431. Communication on firing line by means of signals. The discipline necessary in the firing line will be absent unless officers and noncommissioned officers can make their will known to the men. In the company, therefore, communication must be by simple signals which, in the roar of musketry, will attract the attention and convey the correct meaning. (417)

Expenditure of Ammunition

432. Use of ammunition in attack. In attack the supply is more limited than in defense. Better judgment must be exercised in expenditure. Ordinarily, troops in the firing line of an attack can not expect to have that day more ammunition than they carry into the combat, except such additions as come from the distribution of ammunition of dead and wounded and the surplus brought by reënforcements. (418)

433. True economy in expenditure of ammunition. When a certain fire effect is required, the necessary ammunition must be expended without hesitation. Several hours of firing may be necessary to gain fire superiority. True economy can be practiced only by closing on the enemy, as explained in [par. 344](#), before first opening fire, and thereafter suspending fire when there is

Supporting Artillery

434. Artillery fire principal aid of infantry. Artillery fire is the principal aid to the infantry in gaining and keeping fire superiority, not only by its hits, but by the moral effect it produces on the enemy. (420)

435. Functions of artillery fire in attack and defense. In attack, artillery assists the forward movement of the infantry. It keeps down the fire of the hostile artillery and seeks to neutralize the hostile infantry by inflicting losses upon it, destroying its morale, driving it to cover, and preventing it from using its weapons effectively.

In defense, it ignores the hostile artillery when the enemy's attack reaches a decisive stage and assists in checking the attack, joining its fire power to that of the defending infantry. (421)

436. Fire of artillery over friendly troops. Troops should be accustomed to being fired over by friendly artillery and impressed with the fact that the artillery should continue firing upon the enemy until the last possible moment. The few casualties resulting from shrapnel bursting short are trifling compared with those that would result from the increased effectiveness of the enemy's infantry fire were the friendly artillery to cease firing.

Casualties inflicted by supporting artillery are not probable until the opposing infantry lines are less than 200 yards apart. (422)

437. When no longer safe for artillery to fire over friendly troops. When the distance between the hostile infantry lines becomes so short as to render further use of friendly artillery inadvisable, the commander of the infantry firing line, using a preconcerted signal,^[5] informs the artillery commander. The latter usually increases the range in order to impede the strengthening of the enemy's foremost line, as explained in [pars. 345-346](#). (423)

[Pg 116]

Fire of Position

438. Fire of position, when used. Infantry is said to execute fire of position when it is posted so as to assist an attack by firing over the heads, or off the flank, of the attacking troops and is not itself to engage in the advance; or when, in defense, it is similarly posted to augment the fire of the main firing line.

Machine guns serve a like purpose, as set forth in [par. 555](#).

In a decisive action, fire of position should be employed whenever the terrain permits and reserve infantry is available. (424)

DEPLOYMENT

439. Formation of troops before and during deployment. Troops are massed preparatory to deployment when the nature of their deployment can not be foreseen or it is desirable to shorten the column or to clear the road. Otherwise, in the deployment of large commands, whether in march column, in bivouac, or massed, and whether forming, for attack or for defense, they are ordinarily first formed into a line of columns to facilitate the extension of the front prior to deploying.

The rough line or lines of columns thus formed enable troops to take advantage of the terrain in advancing and shorten the time occupied in forming the firing line. (425)

440. Action of brigade and regimental commanders in deployment of division. In deploying the division, each brigade is assigned a definite task or objective. On receipt of his orders, the brigade commander conducts his brigade in column or in line of regiments, until it is advisable that it be broken into smaller columns. He then issues his order, assigning to each regiment its task, if practicable. In a similar manner the regimental commanders lead their regiments forward in column, or in line of columns, until the time arrives for issuing the regimental order. It is seldom advisable to break up the battalion before issuing orders for its deployment. (426)

441. Personal reconnaissance before deployment. Each subordinate commander, after receiving his order for the action, should precede his command as far as possible, in order to reconnoiter the ground personally, and should prepare to issue his orders promptly. (427)

442. Each commander to guard his command against surprise. Each commander of a column directs the necessary reconnaissance to front and flanks; by this means and by a judicious choice of ground he guards against surprise. (428)

443. Premature formation of firing line to be avoided. The premature formation of the firing line causes unnecessary fatigue and loss of time, and may result in a faulty direction being taken. Troops once deployed make even minor changes of direction with difficulty, and this difficulty increases with the length of the firing line. (429)

444. Rectification of deployment in wrong direction. In the larger units, when the original deployment is found to be in the wrong direction, it will usually be necessary to deploy the reserve on the correct front and withdraw and assemble the first line. (430)

[Pg 117]

445. Number of troops to be deployed in beginning. To gain decisive results, it will generally be necessary to use all the troops at some stage of the combat. But in the beginning, while the situation is uncertain, care should be taken not to engage too large a proportion of the command. On the other hand, there is no greater error than to employ too few and to sacrifice them by dribbles. (For division of the battalion in attack see 335-339.) (431)

446. Dense, well-directed, and controlled line of heavy fire gives fire superiority. When it is intended to fight to a decision, fire superiority is essential. To gain this, two things are necessary: A heavy fire and a fire well-directed and controlled. Both of these are best obtained when the firing line is as dense as practicable, while leaving the men room for the free use of their rifles.

If the men are too widely separated, direction and control are very difficult, often impossible, and the intensity of fire is slight in proportion to the front occupied. (432)

447. Density of 1 man per yard; occupation of only sections of long lines. In an attack or stubborn defense the firing line should have a density of one man per yard of front occupied.

Where the tactical situation demands the holding of a line too long to be occupied throughout at this density, it is generally better to deploy companies or platoons at one man per yard, leaving gaps in the line between them, than to distribute the men uniformly at increased intervals. (433)

448. Use of thin firing line. A relatively thin firing line may be employed when merely covering the movements of other forces; when on the defensive against poor troops; when the final action to be taken has not yet been determined; and, in general, when fire superiority is not necessary. (434)

449. Length of firing line employed by whole force; strength of supports and reserves; density of charging line. The length of the firing line that the whole force may employ depends upon the density of the line and the strength in rear required by the situation.

Supports and reserves constitute the strength in rear.

In a decisive attack they should be at least strong enough to replace a heavy loss in the original firing line and to increase the charging line to a density of at least one and one-half men per yard and still have troops in rear for protection and for the other purposes mentioned above. (435)

450. Strength of reserve; troops deployed varying from 1 to 10 men per yard. In the original deployment the strength of the reserve held out by each commander comprises from one-sixth to two-thirds of his unit, depending upon the nature of the service expected of the reserve.

A small force in a covering or delaying action requires very little strength in rear, while a large force fighting a decisive battle requires much. Therefore, depending upon circumstances, the original deployment, including the strength in rear, may vary from 1 to 10 men per yard. Against an enemy poorly disciplined and trained, or lacking in morale, a thinner deployment is permissible. (436)

[Pg 118]

451. Density of whole deployment varies with size of command. The density of the whole deployment increases with the size of the command, because the larger the command the greater the necessity for reserves. Thus, battalion acting alone may attack two men per yard of front, but a regiment, with three battalions, may only double the front of the one battalion. (437)

452. Division of battle line into battle districts and density of deployment therein. By the assignment of divisions or larger units to parts of a line of battle several miles long, a series of semi-independent battle, or local combat, districts are created.

The general deployment for a long line of battle comprising several battle districts is not directly considered in these regulations. The deployments treated of herein are those of the infantry within such districts.

The density of deployment in these districts may vary greatly, depending upon the activity expected in each. Within these battle districts, as well as in smaller forces acting alone, parts of the line temporarily of less importance may be held weakly, in order to economize troops and to have more at the decisive point. (438)

453. Extent of front occupied by a unit depends upon security of flanks. The front that a unit may occupy when deployed depends also upon whether its flanks are secured. If both flanks are secured by other troops, the unit may increase its front materially by reducing its reserve or

supports. If only one flank is so secured, the front may still be somewhat increased, but the exposed flank must be guarded by posting the supports or reserve toward that flank.

Natural obstacles that secure the flanks have practically the same effect upon deployment. (439)

454. Regiments, battalions, and companies deployed side by side. Except when assigned as supports or reserve, regiments in the brigade, battalions in the regiment, and companies in the battalion are, when practicable, deployed side by side. (440)

455. Battalions furnish firing line and supports; larger units furnish reserves; employment of reserve. In the deployment, battalions establish the firing line, each furnishing its own support.

In each unit larger than the battalion a reserve is held out, its strength depending upon circumstances. In general, the reserve is employed by the commander to meet or improve conditions brought about by the action of the firing line. It must not be too weak or too split up. It must be posted where the commander believes it will be needed for decisive action, or where he desires to bring about such action. When necessary, parts of it reënforce or prolong the firing line. (441)

ATTACK

[Pg 119]

(For the battalion in Attack, see [pars. 342-346](#))

456. Fire superiority means success; how to obtain fire superiority. An attack is bound to succeed if fire superiority is gained and properly used.

To gain this superiority generally requires that the attack employ more rifles than the defense; this in turn means a longer line, as both sides will probably hold a strong firing line. (442)

457. When frontal attack may be successful. With large forces, a direct frontal attack gives the attacker little opportunity to bring more rifles to bear. However, if the enemy is unduly extended, a frontal attack may give very decisive results. (443)

458. When turning movements are allowable. Owing to the difficulty of control and the danger of the parts being defeated in detail, wide turning movements are seldom allowable except in large forces. (444)

459. Advantages of enveloping attack. If the attack can be so directed that, while the front is covered, another fraction of the command strikes a flank more or less obliquely (an enveloping attack), the advantages gained are a longer line and more rifles in action; also a converging fire opposed to the enemy's diverging fire. (445)

460. Envelopment of both flanks. An envelopment of both flanks should never be attempted without a very decided superiority in numbers. (446)

461. Enveloping attacks result in local frontal attacks; advantage of envelopment. The enveloping attack will nearly always result locally in a frontal attack, for it will be met by the enemy's reserve. The advantage of envelopment lies in the longer concentric line, with its preponderance of rifles and its converging fire. (447)

462. Coöperation between frontal and enveloping attacks; the two attacks to be deployed considerable distance from hostile positions. Coöperation between the frontal and enveloping attacks is essential to success. Both should be pushed vigorously and simultaneously, and ordinarily both should move simultaneously to the charge; but at the final stage of the attack conditions may sometimes warrant one in charging while the other supports it with fire.

The envelopment of a flank is brought about with difficulty when made by troops already deployed in another direction or by their reserves. The two attacks should be deployed at a suitable distance apart, with the lines of attack converging in rear of the hostile position. The troops that are to make the enveloping attack should deploy in the proper direction at the start and should be given orders which enable them to gain their point of deployment in the most direct and practical manner.

The enveloping attack is generally made the stronger, especially in small forces. (448)

[Pg 120]

DEPLOYMENT FOR ATTACK

463. Distance from hostile position at which deployment is made; foreground to be cleared of hostile detachments before deployment. Where open terrain exposes troops to hostile artillery fire it may be necessary to make the deployment 2 miles or more from the hostile position.

The foreground should be temporarily occupied by covering troops. If the enemy occupies the foreground with detachments, the covering troops must drive them back. (449)

464. Moving well forward and deploying at night. To enable large forces to gain ground toward the enemy, it may sometimes be cheaper and quicker in the end to move well forward and to deploy at night. In such case the area in which the deployment is to be made should, if practicable, be occupied by covering troops before dark.

The deployment will be made with great difficulty unless the ground has been studied by daylight. The deployment gains little unless it establishes the firing line well within effective range of the enemy's main position. (See Night Operations, [par. 580-590.](#)) (450)

465. Each unit deploys on its direction line; intervals between battalions on firing line. Each unit assigned a task deploys when on its direction line, or opposite its objective, and when it has no longer sufficient cover for advancing in close order. In the firing line, intervals of 25 to 50 yards should be maintained as long as possible between battalions. In the larger units it may be necessary to indicate on the map the direction or objective, but to battalion commanders it should be pointed out on the ground. (451)

466. Post of reserve; reserve charged with flank protection. The reserve is kept near enough to the firing line to be on hand at the decisive stage. It is posted with reference to the attack, or to that part of the attacking line, from which the greater results are expected; it is also charged with flank protection, but should be kept intact.

Supports are considered in [paragraphs 262](#) to 265, inclusive, and [335](#) to 339, inclusive. (452)

ADVANCING THE ATTACK

467. Firing line to advance as far as possible before opening fire. The firing line must ordinarily advance a long distance before it is justified in opening fire. It can not combat the enemy's artillery, and it is at a disadvantage if it combats the defender's long-range rifle fire. Hence it ignores both and, by taking full advantage of cover and of the discipline of the troops, advances to a first firing position at the shortest range possible, as explained in [par. 344.](#)

Formations for crossing this zone with the minimum loss are considered in [paragraphs 249](#) to 257, inclusive. These and other methods of crossing such zones should be studied and practiced. (453)

468. Invisibility best protection while advancing. The best protection against loss while advancing is to escape the enemy's view. (454)

469. Advance of battalions. Each battalion finds its own firing position, conforming to the general advance as long as practicable and taking advantage of the more advanced position of an adjacent battalion in order to gain ground. [Pg 121]

The position from which the attack opens fire is further considered in [paragraphs 343-345,](#) inclusive. (455)

470. Infantry moving to the attack passing through deployed artillery. It will frequently become necessary for infantry moving to the attack to pass through deployed artillery. This should be done so as to interfere as little as possible with the latter's fire, and never so as to cause that fire to cease entirely. As far as practicable, advantage should be taken of intervals in the line, if any. An understanding between artillery and infantry commanders should be had, so as to effect the movement to the best advantage. (456)

471. Advanced elements of firing line not to open fire on main hostile position. In advancing the attack, advanced elements of the firing line or detachments in front of it should not open fire except in defense or to clear the foreground of the enemy. Fire on the hostile main position should not be opened until all or nearly all of the firing line can join in the fire. (457)

THE FIRE ATTACK

(See [pars. 414-438.](#))

472. Fire superiority sought at first firing position, and to be maintained until charging point is reached; size of rushing units. At the first firing position the attack seeks to gain fire superiority. This may necessitate a steady, accurate fire a long time. The object is to subdue the enemy's fire and keep it subdued so that the attacking troops may advance from this point to a favorable place near the enemy from which the charge may be made. Hence, in the advance by rushes, sufficient rifles must be kept constantly in action to keep down the enemy's fire; this determines the size of the fraction rushing. (458)

473. Futility of advancing without fire superiority. To advance without fire superiority against a determined defense would result in such losses as to bring the attack to a standstill or to make the apparent success barren of results. (459)

474. Signs that fire superiority has been gained. Diminution of the enemy's fire and a pronounced loss in effectiveness are the surest signs that fire superiority has been gained and that a part of the firing line can advance. (460)

475. Retiring under fire in daylight suicidal; intrenching. The men must be impressed with the fact that, having made a considerable advance under fire and having been checked, it is suicidal to turn back in daylight.

If they can advance no farther, they must intrench and hold on until the fall of darkness or a favorable turn in the situation develops.

Intrenching is resorted to only when necessary. Troops who have intrenched themselves under fire are moved forward again with difficulty. (461)

476. Supports and reserves occupying trenches vacated by firing line, to improve same. Supports and reserves occupying intrenchments vacated by the firing line should improve them, but they must not be held back or diverted from their true missions on this account. (462)

[Pg 122]

477. Greater detail of conduct of fire attack. [Paragraphs 346](#) to 354, inclusive, deal more in detail with the conduct of the fire attack. (463)

THE CHARGE

(See [pars. 355](#)-356)

478. What fire superiority accomplishes; psychological moment for charge determined by tactical instinct. Fire superiority beats down the enemy's fire, destroys his resistance and morale, and enables the attacking troops to close on him, but an actual or threatened occupation of his position is needed to drive him out and defeat him.

The psychological moment for the charge can not be determined far in advance. The tactical instinct of the responsible officer must decide. (464)

479. When, and distance over which charge should be made.

The defenders, if subjugated by the fire attack, will frequently leave before the charge begins. On the other hand, it may be necessary to carry the fire attack close to the position and follow it up with a short dash and a bayonet combat. Hence the distance over which the charge may be made will vary between wide limits. It may be from 25 to 400 yards.

The charge should be made at the earliest moment that promises success; otherwise the full advance of victory will be lost. (465)

480. Charge to be made with approval of commander of attacking line; battalion commanders signal commander of line when ready to charge; charge to be made simultaneously. The commander of the attacking line should indicate his approval, or give the order, before the charge is made. Subordinate commanders, usually battalion commanders, whose troops are ready to charge, signal that fact to the commander. It may be necessary for them to wait until other battalions or other parts of the line are ready or until the necessary reserves arrive.

At the signal for the charge the firing line and nearby supports and reserves rush forward. (See [pars. 355](#) and [356](#).)

The charge is made simultaneously, if possible, by all the units participating therein, but once committed to the assault, battalions should be pushed with the utmost vigor and no restraint placed on the ardor of charging troops by an attempt to maintain alignment. (466)

481. Charge not to be made without sufficient troops; reserves give impetus; avoiding too dense a mass. Before ordering the charge the commander should see that enough troops are on hand to make it a success. Local reserves joining the firing line in time to participate in the charge give it a strong impetus. Too dense a mass should be avoided. (467)

482. Line to be strengthened by prolongation. The line should be strengthened by prolongation, if practicable, and remaining troops kept in formation for future use; but rather than that the attack should fail, the last formed body will be sent in, unless it is very apparent that it can do no good. (468)

483. Additional force for pursuit. To arrive in the hostile position with a very compact firing line and a few formed supports is sufficient for a victory, but an additional force kept well in hand

[Pg 123]

for pursuit is of inestimable value. (469)

484. Premature charge to be avoided; charging without authority from the rear. A premature charge by a part of the line should be avoided, but if begun, the other parts of the line should join at once if there is any prospect of success. Under exceptional conditions a part of the line may be compelled to charge without authority from the rear. The intention to do so should be signaled to the rear. (470)

485. Confidence in ability to use bayonet. Confidence in their ability to use the bayonet gives the assaulting troops the promise of success. (471)

486. Pursuing fire; disordered units not to pursue. If the enemy has left the position when the charging troops reach it, the latter should open a rapid fire upon the retreating enemy, if he is in sight. It is not advisable for the mixed and disordered units to follow him, except to advance to a favorable firing position or to cover the reorganization of others. (472)

487. Pursuing troops; reorganization of charging line; preparations to meet counter-attack. The nearest formed bodies accompanying or following the charge are sent instantly in pursuit. Under cover of these troops order is restored in the charging line. If the captured position is a part of a general line or is an advanced post, it should be intrenched and occupied at once.

The exhaustion of officers and men must not cause the neglect of measures to meet a counter-attack. (473)

488. Steps to be taken when attack receives temporary setback. If the attack receives a temporary setback and it is intended to strengthen and continue it, officers will make every effort to stop the rearward movement and will reestablish the firing line in a covered position as close as possible to the enemy. (474)

489. Steps to be taken if attack is abandoned. If the attack must be abandoned, the rearward movement should continue with promptness until the troops reach a feature of the terrain that facilitates the task of checking and reorganizing them. The point selected should be so far to the rear as to prevent interference by the enemy before the troops are ready to resist. The withdrawal of the attacking troops should be covered by the artillery and by reserves, if any are available.

(See Night Operations, [pars. 580-590.](#)) (475)

PURSUIT

490. Full fruits of victory reaped by pursuit. To reap the full fruits of victory a vigorous pursuit must be made. The natural inclination to be satisfied with a successful charge must be overcome. The enemy must be allowed no more time to reorganize than is positively unavoidable. (476)

491. Parts played in pursuit by reserve, artillery, and charging troops. The part of the reserve that is still formed or is best under control is sent forward in pursuit and vigorously attacks the enemy's main body or covering detachments wherever found. [Pg 124]

The artillery delivers a heavy fire upon the retreating enemy; the disordered attacking troops secure the position, promptly reform and become a new reserve. (477)

492. Strengthening of position captured, if section of general line. If the captured position is a section of the general line, the breach should be heavily occupied, made wider, and strongly secured by drawing on all reserves in the vicinity. (478)

493. Pursuit by parallel roads. After the pursuit from the immediate battlefield, pursuit by parallel roads is especially effective where large commands are concerned. (479)

494. Artillery and cavalry in pursuit. Artillery and cavalry are very effective in pursuit. (480)

ATTACK OF FORTIFICATIONS

495. Modifications of attack in case of fortifications. Few modifications enter into the problem of attacking fortifications. Such as are to be considered relate chiefly to the greater time and labor of advancing, the more frequent use of darkness and the use of hand grenades to augment the fire. (481)

496. Approaching charging point under cover of darkness. If the enemy is strongly fortified and time permits, it may be advisable to wait and approach the charging point under cover of darkness. The necessary reconnaissance and arrangements should be made before dark. If the

charge is not to be made at once, the troops intrench the advanced position, using sand bags if necessary. Before daylight the foreground should be cleared of obstacles. (482)

497. Charging without fire preparation. If the distance is short and other conditions are favorable, the charge may be made without fire preparation. If made, it should be launched with spirit and suddenness at the break of day. (See Night Operations [pars. 580–590.](#)) (483)

498. Advancing to charging point by sapping. In siege operations troops are usually advanced to the charging point by sapping. This method, however, presupposes that an early victory is not necessary, or that it is clearly inadvisable to attempt more direct methods. (484)

HOLDING ATTACK

499. Requisites of the holding attack. The holding attack must be vigorous enough to hold the enemy in position and must present a front strong enough to conceal the secondary nature of the attack.

The holding attack need have comparatively little strength in rear, but conceals the fact by a firing line not distinguishable from that of a decisive attack. (485)

500. Post and strength of supports and reserves. Supports and reserves are kept at short distances. Their strength is less if the object is merely to hold the enemy fast than if the object is, in addition, to compel him to use up reserves. (486)

501. Holding attacks developing into decisive attacks. Holding attacks which may later develop into decisive attacks should be correspondingly strong in rear. (487)

[Pg 125]

502. Feint attacks. All feint attacks should employ dense firing lines. Their weakness is in rear and is concealed. (488)

DEFENSE

POSITIONS AND INTRENCHMENTS

503. Requirements of a good defensive position. The first requirement of a good position is a clear field of fire and view to the front and exposed flanks to a distance of 600 to 800 yards or more. The length of front should be suitable to the size of the command and the flanks should be secure. The position should have lateral communication and cover for supports and reserves. It should be one which the enemy can not avoid, but must attack or give up his mission.

A position having all these advantages will rarely, if ever, be found. The one should be taken which conforms closest to the description. (489)

504. Utilization of natural cover; construction of fieldworks and obstacles. The natural cover of the position should be fully utilized. In addition, it should be strengthened by fieldworks and obstacles.

The best protection is afforded by deep, narrow, inconspicuous trenches. If little time is available, as much as practicable must be done. That the fieldworks may not be needed should not cause their construction to be omitted, and the fact that they have been constructed should not influence the action of a commander, if conditions are found to be other than expected. (490)

505. Construction of communicating and cover trenches, head cover, etc. When time and troops are available the preparations include the necessary communicating and cover trenches, head cover, bombproofs, etc. The fire trenches should be well supplied with ammunition.

The supports are placed close at hand in cover trenches when natural cover is not available. (491)

506. Dummy trenches. Dummy trenches frequently cause the hostile artillery to waste time and ammunition and to divert its fire. (492)

507. Location, extent, garrison, etc., of fieldworks. The location, extent, profile, garrison, etc., of fieldworks are matters to be decided by the infantry commanders. Officers must be able to choose ground and properly intrench it. (See "Field Fortifications," Chapter XVI, Part III.) (493)

508. Outlining trace of trenches in combat exercises. In combat exercises, when it is impracticable to construct the trenches appropriate to the exercise, their trace may be outlined by bayonets, sticks, or other markers, and the responsible officers required to indicate the profile selected, method and time of construction, garrisons, etc. (494)

509. Density of whole deployment. The density of the whole deployment depends upon the expected severity of the action, the character of the enemy, the condition of the flanks, the field of fire, the terrain, and the available artificial or natural protection for the troops. (495)

[Pg 126]

510. Density of firing line. If exposed, the firing line should be as dense in defense as in attack. If the firing line is well intrenched and has a good field of fire, it may be made thinner.

Weaker supports are permissible. For the same number of troops the front occupied on the defensive may therefore be longer than on the offensive, the battalions placing more companies in the firing line. (496)

511. Strength in rear to be increased when change from defensive to offensive is contemplated. If it is intended only to delay the enemy, a fairly strong deployment is sufficient, but if decisive results are desired, a change to the offensive must be contemplated and the corresponding strength in rear provided. This strength is in the reserve, which should be as large as the demands of the firing line and supports permit. Even in a passive defense the reserve should be as strong as in the attack; unless the flanks are protected by other means. (497)

512. Post of supports; cover for supports. Supports are posted as close to the firing line as practicable and reinforce the latter according to the principles explained in the attack. When natural cover is not sufficient for the purpose, communicating and cover trenches are constructed. If time does not permit their construction, it is better to begin the action with a very dense firing line and no immediate supports than to have supports greatly exposed in rear. (498)

513. Post of reserve. The reserve should be posted so as to be entirely free to act as a whole, according to the developments. The distance from firing line to reserve is generally greater than in the attack. By reason of such a location the reserve is best able to meet a hostile enveloping attack; it has a better position from which to make a counter attack; it is in a better position to cover a withdrawal and permit an orderly retreat.

The distance from firing line to reserve increases with the size of the reserve. (499)

514. Post of reserve when situation is no longer in doubt. When the situation is no longer in doubt, the reserve should be held in rear of the flank which is most in danger or offers the best opportunity for counter attack. Usually the same flank best suits both purposes. (500)

515. Detaching part of reserve to protect opposite flank. In exceptional cases, on broad fronts, it may be necessary to detach a part of the reserve to protect the opposite flank. This detachment should be the smallest consistent with its purely protective mission. (501)

516. Assignment of front to units. The commander assigns to subordinates the front to be occupied by them. These, in turn, subdivide the front among their next lower units in the firing line. (502)

517. Division of extended position into sections. An extended position is so divided into sections that each has, if practicable, a field of fire naturally made distinct by the terrain.

Unfavorable and unimportant ground will ordinarily cause gaps to exist in the line. (503)

518. Size of units occupying sections; battalions to be kept intact. The size of the unit occupying each section depends upon the latter's natural strength, front, and importance. If practicable, battalions should be kept intact and assigned as units to sections or parts of sections. (504)

[Pg 127]

519. Adjoining sections or machine guns to cover dead space. Where important dead space lies in front of one section, an adjoining section should be instructed to cover it with fire when necessary, or machine guns should be concealed for the like purpose. (505)

520. Advanced posts and other dispersion to be avoided. Advanced posts, or any other form of unnecessary dispersion, should be avoided. (506)

521. Position itself not fully occupied until infantry attack begins. Unless the difficulty of moving the troops into the position be great, most of the troops of the firing line are held in rear of it until the infantry attack begins. The position itself is occupied by a small garrison only, with the necessary outguards or patrols in front. (507)

522. Fire alone unable to stop attack. Fire alone can not be depended upon to stop the attack. The troops must be determined to resort to the bayonet, if necessary. (508)

523. Steps to be taken if night attack is expected. If a night attack or close approach by the enemy is expected, troops in a prepared position should strengthen the outguards and firing line and construct as numerous and effective obstacles as possible. Supports and local reserves should move close to the firing line and should, with the firing line, keep bayonets fixed. If

practicable, the front should be illuminated, preferably from the flanks of the section. (509)

524. Short range fire and bayonet in night attack. Only short range fire is of any value in resisting night attacks. The bayonet is the chief reliance. (See Night Operations [pars. 580-590.](#)) (510)

COUNTER ATTACK

525. Passive defense; only offensive wins. The passive defense should be assumed only when circumstances force it. Only the offensive wins. (511)

526. Active defense seeks favorable decision; counter attack necessary. An active defense seeks a favorable decision. A favorable decision can not be expected without counter attack. (512)

527. Protection of flanks by natural obstacles necessary in passive defense position. A passive defense in a position whose flanks are not protected by natural obstacles is generally out of the question. (513)

528. Post of troops for counter attack. Where the defense is assumed with a view to making a counter attack, the troops for the counter attack should be held in reserve until the time arrives for such attack. The defensive line should be held by as few troops as possible in order that the force for the offensive may be as large as possible.

The force for the counter attack should be held echeloned in rear of the flank which offers it the greatest advantage for the proposed attack. (514)

529. Manner of making counter attack. The counter attack should be made vigorously and at the proper time. It will usually be made:

[Pg 128]

By launching the reserve against the enemy's flank when his attack is in full progress. This is the most effective form of counter attack.

Straight to the front by the firing line and supports after repulsing the enemy's attack and demoralizing him with pursuing fire.

Or, by the troops in rear of the firing line when the enemy has reached the defensive position and is in disorder. (515)

530. Minor counter attacks. Minor counter attacks are sometimes necessary in order to drive the enemy from important positions gained by him. (516)

DELAYING ACTION

531. The important considerations in a delaying action. When a position is taken merely to delay the enemy and to withdraw before becoming closely engaged, the important considerations are:

The enemy should be forced to deploy early. The field of fire should therefore be good at distances from 500 to 1,200 yards or more; a good field of fire at close range is not necessary.

The ground in rear of the position should favor the withdrawal of the firing line by screening the troops from the enemy's view and fire as soon as the position is vacated. (517)

532. Thin firing line answers purpose; purposes of supports and reserve. A thin firing line using much ammunition will generally answer the purpose. Supports are needed chiefly to protect the flanks.

The reserve should be posted well in rear to assist in the withdrawal of the firing line. (518)

533. Value of artillery. Artillery is especially valuable to a delaying force. (519)

MEETING ENGAGEMENTS

534. Characteristics of meeting engagements. Meeting engagements are characterized by the necessity for hasty reconnaissance, or the almost total absence of reconnaissance; by the necessity for rapid deployment, frequently under fire; and usually by the absence of trenches or other artificial cover. These conditions give further advantages to the offensive. (520)

535. General action on meeting enemy. The whole situation will usually indicate beforehand the proper general action to be taken on meeting the enemy. (521)

536. Meagerness of information; qualities of commander to be relied upon. Little fresh information can be expected. The boldness, initiative, and determination of the commander must be relied upon. (522)

537. Meeting engagement affords ideal opportunity to certain commanders. A meeting engagement affords an ideal opportunity to the commander who has intuition and quick decision and who is willing to take long chances. His opponent is likely to be overcautious. (523)

538. The mission determines method of attack. The amount of information that the commander is warranted in awaiting before taking final action depends entirely upon his mission. One situation may demand a blind attack; another may demand rapid, partial deployment for attack, but careful and time-consuming reconnaissance before the attack is launched. (524)

[Pg 129]

539. Advantage accrues to side deploying the faster. A great advantage accrues to the side which can deploy the faster. The advantage of a close-order formation, favoring rapid deployment, becomes more pronounced with the size of the force. (525)

540. Advantages of first troops to deploy. The first troops to deploy will be able to attack with longer firing lines and weaker supports than are required in the ordinary case. But if the enemy succeeds in deploying a strong defensive line, the attack must be strengthened accordingly before it is wasted. (526)

541. Things to be done by the leading troops. If the situation warrants the advance, the leading troops seek to deploy faster than the enemy, to reach his flanks, check his deployment, and get information. In any event, they seek to cover the deployment of their own troops in rear—especially the artillery—and to seize important ground. (527)

542. Post of commander of long column meeting enemy; function of advance guard; action of column. The commander of a long column which meets the enemy should be with the advance guard to receive information promptly and to reconnoiter. If he decides to fight, the advance guard must hold the enemy while the commander formulates a plan of action, issues the necessary orders, and deploys the main body. Meantime, the column should be closing up, either in mass or to form line of columns, so that the deployment, when determined upon, may be made more promptly. (528)

543. Action of advance guard prior to receipt of orders. The action of the advance guard, prior to the receipt of orders, depends upon the situation. Whether to attack determinedly or only as a feint, or to assume the defensive, depends upon the strength of the advance guard, the terrain, the character of the hostile force encountered, and the mission and intentions of the commander of the whole. (529)

544. Main body should be used as a whole and not put into action piecemeal. If the enemy is beforehand or more aggressive, or if the advance guard is too weak, it may be necessary to put elements of the main body into action as fast as they arrive, in order to check him. This method should be avoided; it prevents the formation and execution of a definite plan and compels piecemeal action. The best results are obtained when the main body is used as a whole. (530)

WITHDRAWAL FROM ACTION

545. Withdrawal generally effected at heavy cost; rear guard and distance to be placed between enemy and defeated troops. The withdrawal of a defeated force can generally be effected only at a heavy cost. When it is no longer possible to give the action a favorable turn and the necessity for withdrawal arises, every effort must be made to place distance and a rear guard between the enemy and the defeated troops. (531)

546. Use of artillery, machine guns, and cavalry. Artillery gives especially valuable assistance in the withdrawal. The long-range fire of machine guns should also be employed. Cavalry assists the withdrawal by charging the pursuing troops or by taking flank positions and using fire action. (532)

[Pg 130]

547. Use of reserve to check the pursuit. If an intact reserve remains, it should be placed in a covering position, preferably on a flank, to check the pursuit and thus enable the defeated troops to withdraw beyond reach of hostile fire.

The covering position of the reserve should be at some distance from the main action, but close enough to bring the withdrawing troops quickly under the protection of its fire. It should have a good field of fire at effective and long ranges and should facilitate its own safe and timely withdrawal. (533)

548. Part of line to be withdrawn first; retreating troops to be gotten under control as soon as possible. If the general line is divided, by terrain or by organization, into two or more parts, the firing line of the part in the least danger from pursuit should be withdrawn first. A continuous firing line, whose parts are dependent upon one another for fire support, should be

withdrawn as a whole, retiring by echelon at the beginning of the withdrawal. Every effort must be made to restore the organizations, regain control, and form column of march as soon as the troops are beyond the reach of hostile fire.

As fast as possible without delaying the march, companies, and the larger units should be reformed, so that the command will again be well in hand. (534)

549. Action taken by commander; selection of rendezvous point. The commander of the whole, having given orders for withdrawal, should go to the rear, select a rendezvous point, and devote himself to the reorganization of his command.

The rendezvous point is selected with regard to the natural channels of movement approximately straight to the rear. It should be distant from the battlefield and should facilitate the gathering and protection of the command. (535)

SUMMARY

550. 1. Avoid combats that offer no chance of victory or other valuable results.

2. Make every effort for the success of the general plan and avoid spectacular plays that have no bearing on the general result.

3. Have a definite plan and carry it out vigorously. Do not vacillate.

4. Do not attempt complicated maneuvers.

5. Keep the command in hand; avoid undue extension and dispersion.

6. Study the ground and direct the advance in such a way as to take advantage of all available cover and thereby diminish losses.

7. Never deploy until the purpose and the proper direction are known.

8. Deploy enough men for the immediate task in hand; hold out the rest and avoid undue haste in committing them to the action. [Pg 131]

9. Flanks must be protected either by reserves, fortifications, or the terrain.

10. In a decisive action, gain and keep fire superiority.

11. Keep up reconnaissance.

12. Use the reserve, but not until needed or a very favorable opportunity for its use presents itself. Keep some reserve as long as practicable.

13. Do not hesitate to sacrifice the command if the result is worth the cost.

14. Spare the command all unnecessary hardship and exertion. (536)

MACHINE GUNS

551. Machine guns are weapons of emergency. Machine guns must be considered as weapons of emergency. Their effectiveness combined with their mobility renders them of great value at critical, though infrequent, periods of an engagement. (537)

552. Machine guns to be used for short periods, when opportunities present themselves. When operating against infantry only, they can be used to a great extent throughout the combat as circumstances may indicate, but they are quickly rendered powerless by efficient field artillery and will promptly draw artillery fire whenever they open. Hence their use in engagements between large commands must be for short periods and at times when their great effectiveness will be most valuable. (538)

553. Machine guns attached to advance guard; use in meeting engagements. Machine guns should be attached to the advance guard. In meeting engagements they will be of great value in assisting their own advance, or in checking the advance of the enemy, and will have considerable time to operate before hostile artillery fire can silence them.

Care must be taken not to leave them too long in action. (539)

554. Use of machine guns with rear guard. They are valuable to a rear guard which seeks to check a vigorous pursuit or to gain time. (540)

555. Machine guns in attack; fire of position. In attack, if fire of position is practicable, they are of great value. In this case fire should not be opened by the machine guns until the attack is well advanced. At a critical period in the attack, such fire, if suddenly and unexpectedly opened, will greatly assist the advancing line. The fire must be as heavy as possible and must be

continued until masked by friendly troops or until the hostile artillery finds the machine guns. (541)

556. Machine guns in defense. In the defense, machine guns should be used in the same general manner as described above for the attack. Concealment and patient waiting for critical moments and exceptional opportunities are the special characteristics of the machine-gun service in decisive actions. (542)

557. Machine guns as part of reserve; use in covering withdrawal. As part of the reserve, machine guns have special importance. If they are with the troops told off to protect the flanks, and if they are well placed, they will often produce decisive results against a hostile turning movement. They are especially qualified to cover a withdrawal or make a captured position secure. (543)

[Pg 132]

558. Machine guns not to form part of firing line of attack. Machine guns should not be assigned to the firing line of an attack. They should be so placed that fire directed upon them is not likely to fall upon the firing line. (544)

559. Effectiveness of machine guns against skirmish line, except when lying down or crawling. A skirmish line can not advance by walking or running when hostile machine guns have the correct range and are ready to fire. Machine-gun fire is not specially effective against troops lying on the ground or crawling. (545)

560. Silencing of machine guns by infantry. When opposed by machine guns without artillery to destroy them, infantry itself must silence them before it can advance.

An infantry command that must depend upon itself for protection against machine guns should concentrate a large number of rifles on each gun in turn and until it has silenced it. (546)

In addition to the above, which the Infantry Drill Regulations gives on the subject of machine guns, the following, based on the use of machine guns in the European War, is given:

561. Machine guns essentially automatic rifles. They are essentially automatic rifles, designed to fire the ordinary rifle cartridge and capable of delivering a stream of small bullets at a rate of as high as 600 per minute. Experience in the European war has determined that the rate of 400 shots per minute is the desirable maximum. Their ranges are the same as for the rifle. The fire of a machine gun has been estimated as equal to that of 30 men.

562. Mounts. Machine guns are usually mounted on tripods or wheels. The weight of certain types is such that they can readily be carried by the soldier from one point to another.

563. Methods of transportation. While machine guns are usually designed to be carried or packed, they are easily adapted to various methods of transportation. In the European war we find them mounted on sleds during the winter campaign; on specially designed motor cycles with side cars and accompanied by other motor cycles carrying ammunition; on wheels; on wagons; on armored automobiles; aeroplanes; and finally in the powerful "tanks" of the English.

564. Concealment. Machine guns while usually considered as *weapons of emergency* have been used in attack and defense in the European war in all stages. Their mobility and deadly effect have made them of great value. Once their position is discovered they are quickly put out of action by artillery. Owing to this fact the armies in Europe have used alternative positions and have used every means to conceal the guns. Hedges, walls, and pits are used and every effort is used to conceal the flame of discharge. This is usually accomplished by keeping the muzzle well in rear of its cover or loop hole. Machine guns almost invariably betray their positions as soon as they enter into action. The present tendency seems to be to hold them concealed and place them into position in the trenches or emplacements at the moment of combat.

Extraordinary means have been resorted to in hiding the guns until they are needed. In the German line, dugouts underground were constructed to conceal the machine guns and crews. Often they permitted the first line of the attack to pass over them and then appeared in rear and opened a deadly fire on the backs of the troops.

[Pg 133]

565. Use in villages. In villages, machine guns were used with terrible effect, firing from cellars or windows. The only successful method of destroying them was with hand grenades and even this was costly.

566. Location on the defense. On the *defense* machine guns should be mounted in salients and at points where cross fire can be obtained. This makes it more difficult for the enemy to locate the guns. Frontal fire is not so often successful.

567. Location in attack. In the *attack* it is accepted that machine guns must cover the Infantry at short and long ranges while other machine guns must accompany the attacking troops to hold the positions or trenches gained.

The second or third line would seem to be the best position for machine guns when accompanying troops.

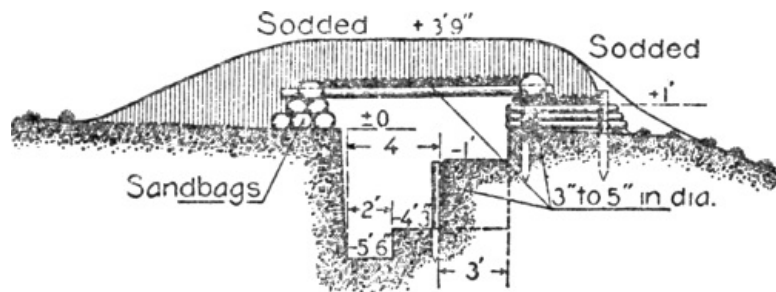

Machine Gun Emplacement: Section aa

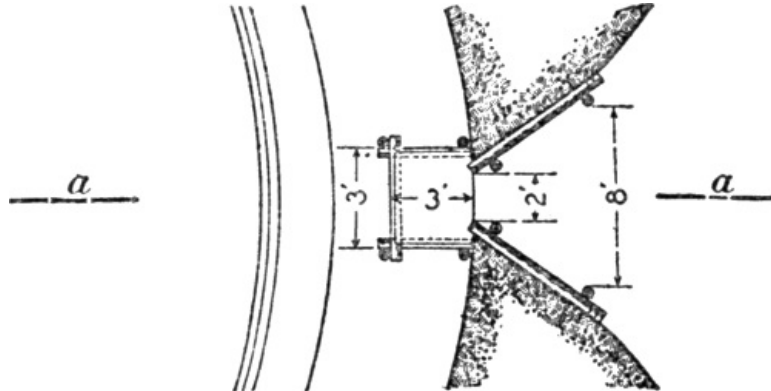

Machine Gun Emplacement: Plan with Cover Removed

568. Economy of men. Owing to its rapid and effective fire, and the comparative ease with which it can be concealed, the machine gun permits a great economy of men on a front and the concentrating of the forces thus freed for use in other parts of the field. This was done on a large scale on the Russian front by the Germans in 1915. They constructed miles of wire entanglements in front of positions occupied with an enormous number of machine guns and comparatively few men. The main forces were thus free to be transported wherever danger threatened. In this manner the Germans replaced men by machine guns and wire and were able to cope successfully with the immense Russian Armies. The above plate shows a typical machine gun emplacement, constructed in the field. Many elaborate emplacements have been constructed in the European war, using steel and concrete, but for a hasty cover in the field the simple emplacement shown in the figure is recommended.

[Pg 134]

(NOTE.—For a more detailed study of machine guns, see Subject XI, Machine Guns in Action, School of Musketry, Fort Sill, Oklahoma, and Combined Cavalry and Infantry Drill Regulations for Automatic Machine Rifle, cal. 30, 1909, War Department, 1915.)

AMMUNITION SUPPLY

569. Method of supplying ammunition to combat train. The method of supply of ammunition to the combat trains is explained in Field Service Regulations. (547)

570. Combat train and the major's responsibility for its proper use; a rendezvous for each brigade. The combat train is the immediate reserve supply of the battalion, and the major is responsible for its proper use. He will take measures to insure the maintenance of the prescribed allowance at all times.

In the absence of instructions, he will cause the train to march immediately in rear of his battalion, and, upon separating from it to enter an engagement, will cause the ammunition therein to be issued. When emptied, he will direct that the wagons proceed to the proper rendezvous to be refilled. Ordinarily a rendezvous is appointed for each brigade and the necessary number of wagons sent forward to it from the ammunition column. (548)

571. Destination of combat wagons when refilled. When refilled, the combat wagons will rejoin their battalions, or, if the latter be engaged, will join or establish communication with the regimental reserve. (549)

572. Company commanders' responsibility for ammunition in belts; ammunition of dead and wounded. Company commanders are responsible that the belts of the men in their companies are kept filled at all times, except when the ammunition is being expended in action. In the firing line the ammunition of the dead and wounded should be secured whenever practicable. (550)

573. Ammunition in bandoleers and 30 rounds in right pocket section. Ammunition in the bandoleers will ordinarily be expended first. Thirty rounds in the right pocket section of the belt will be held as a reserve, to be expended only when ordered by an officer. (551)

574. Ammunition sent forward with reënforcements; men not to be sent back from firing line for ammunition. When necessary to resupply the firing line, ammunition will be sent forward with reënforcements, generally from the regimental reserve. (552)

Men will never be sent back from the firing line for ammunition. Men sent forward with ammunition remain with the firing line.

575. Replenishment of ammunition after engagement. As soon as possible after an engagement the belts of the men and the combat wagons are resupplied to their normal capacities. Ammunition which can not be reloaded on combat wagons will be piled up in a convenient place and left under guard. (553)

MOUNTED SCOUTS

576. Scouts to be trained in patrolling and reconnaissance; their use. The mounted scouts should be thoroughly trained in patrolling and reconnaissance. They are used for communication with neighboring troops, for patrolling off the route of march, for march outposts, outpost patrols, combat patrols, reconnaissance ahead of columns, etc. Their further use is, in general, confined to escort and messenger duty. They should be freely used for all these purposes, but for these purposes only. (554)

577. Use of mounted scouts for reconnoitering. When infantry is acting alone, or when the cavalry of a mixed command has been sent to a distance, the mounted scouts are of special importance to covering detachments and should be used to make the reconnaissance which would otherwise fall to cavalry. (555)

578. Scouts to be used in reconnaissance in preference to other troops; use for dismounted patrolling. In reconnaissance, scouts should be used in preference to other troops as much as possible. When not needed for mounted duty, they should be employed for necessary dismounted patrolling. (556)

579. Training of battalion staff officers in patrolling. Battalion staff officers should be specially trained in patrolling and reconnaissance work in order that they may be available when a mounted officer's patrol is required. (557)

NIGHT OPERATIONS

580. Purposes of night operations. By employing night operations troops make use of the cover of darkness to minimize losses from hostile fire or to escape observation. Night operations may also be necessary for the purpose of gaining time. Control is difficult and confusion is frequently unavoidable.

It may be necessary to take advantage of darkness in order to assault from a point gained during the day, or to approach a point from which a daylight assault is to be made, or to effect both the approach and the assault. (558)

581. Practice in offensive and defensive operations; simple formations. Offensive and defensive night operations should be practiced frequently in order that troops may learn to cover ground in the dark and arrive at a destination quietly and in good order, and in order to train officers in the necessary preparation and reconnaissance.

[Pg 136]

Only simple and well-appointed formations should be employed.

Troops should be thoroughly trained in the necessary details—e. g., night patrolling, night marching, and communication at night. (559)

582. Ground to be studied by day and night, cleared of hostile detachments, etc.; preparation of orders; distinctive badges. The ground to be traversed should be studied by daylight and, if practicable, at night. It should be cleared of hostile detachments before dark, and, if practicable, should be occupied by covering troops.

Orders must be formulated with great care and clearness. Each unit must be given a definite objective and direction, and care must be exercised to avoid collision between units.

Whenever contact with the enemy is anticipated, a distinctive badge should be worn by all. (560)

583. Secrecy of preparations; unfriendly guides; fire action to be avoided, relying upon bayonet. Preparations must be made with secrecy. When the movement is started, and not until then, the officers and men should be acquainted with the general design, the composition of the whole force, and should be given such additional information as will insure coöperation and eliminate mistakes.

During the movement every precaution must be taken to keep secret the fact that troops are abroad.

Unfriendly guides must frequently be impressed. These should be secured against escape, outcry, or deception.

Fire action should be avoided in offensive operations. In general, pieces should not be loaded. Men must be trained to rely upon the bayonet and to use it aggressively. (561)

584. Night marches; advance and rear guards. Long night marches should be made only over well-defined routes. March discipline must be rigidly enforced. The troops should be marched in as compact a formation as practicable, with the usual covering detachments. Advance and rear guard distances should be greatly reduced. They are shortest when the mission is an offensive one. The connecting files are numerous. (562)

585. Night advance followed by attack by day. A night advance made with a view to making an attack by day usually terminates with the hasty construction of intrenchments in the dark. Such an advance should be timed so as to allow an hour or more of darkness for intrenching.

An advance that is to terminate in an assault at the break of day should be timed so that the troops will not arrive long before the assault is to be made; otherwise, the advantage of partial surprise will be lost, and the enemy will be allowed to reënforce the threatened point. (563)

586. Night attacks, when employed; they require trained troops; compact formations; value of bayonet. The night attack is ordinarily confined to small forces, or to minor engagements in a general battle, or to seizure of positions occupied by covering or advanced detachments. Decisive results are not often obtained.

Poorly disciplined and untrained troops are unfit for night attacks or for night operations demanding the exercise of skill and care. [Pg 137]

Troops attacking at night can advance close to the enemy in compact formations and without suffering loss from hostile artillery or infantry fire. The defender is ignorant of the strength or direction of the attack.

A force which makes a vigorous bayonet charge in the dark will often throw a much larger force into disorder. (564)

587. Reconnaissance; attack to be a surprise. Reconnaissance should be made to ascertain the position and strength of the enemy and to study the terrain to be traversed. Officers who are to participate in the attack should conduct this reconnaissance. Reconnaissance at night is especially valuable. Features that are distinguishable at night should be carefully noted, and their distances from the enemy, from the starting point of the troops, and from other important points should be made known.

Preparations should have in view as complete a surprise as possible. An attack once begun must be carried to its conclusion, even if the surprise is not as complete as was planned or anticipated. (565)

588. Time of making attack depends upon object sought. The time of night at which the attack should be made depends upon the object sought. If a decisive attack is intended, it will generally yield the best results if made just before daylight. If the object is merely to gain an intrenched position for further operations, an earlier hour is necessary in order that the position gained may be intrenched under cover of darkness. (566)

589. Formation; use of bayonet; preparations to repel counter attack. The formation for attack must be simple. It should be carefully effected and the troops verified at a safe distance from the enemy. The attacking troops should be formed in compact lines and with strong supports at short distances. The reserve should be far enough in rear to avoid being drawn into the action until the commander so desires. Bayonets are fixed, pieces are not loaded.

Darkness causes fire to be wild and ineffective. The attacking troops should march steadily on the enemy without firing, but should be prepared and determined to fight vigorously with the bayonet.

In advancing to the attack the aim should be to get as close as possible to the enemy before being discovered, then trust to the bayonet.

If the assault is successful, preparations must be made at once to repel a counter attack. (567)

590. Measures taken by defense to resist night attacks. On the defense, preparations to resist night attacks should be made by daylight whenever such attacks are to be feared.

Obstacles placed in front of a defensive position are especially valuable to the defense at night. Many forms of obstacles which would give an attacker little concern in the daytime become serious hindrances at night.

After dark the foreground should be illuminated whenever practicable and strong patrols should be pushed to the front.

When it is learned that the enemy is approaching, the trenches are filled and the supports moved close to the firing line.

Supports fix bayonets, but do not load. Whenever practicable and necessary, they should be used for counter attacks, preferably against a hostile flank. [Pg 138]

The defender should open fire as soon as results may be expected. This fire may avert or postpone the bayonet combat, and it warns all supporting troops. It is not likely that fire alone can stop the attack. The defender must be resolved to fight with the bayonet.

Ordinarily fire will not be effective at ranges exceeding 50 yards.

A white rag around the muzzle of the rifle will assist in sighting the piece when the front sight is not visible.

See [pars. 464, 496, 497, 523, 524](#). (568)

INFANTRY AGAINST CAVALRY

591. Cavalry charge against infantry usually futile. A cavalry charge can accomplish little against infantry, even in inferior numbers, unless the latter are surprised, become panic-stricken, run away, or can not use their rifles. (569)

592. Measures to check charges from front and flank. A charge from the front is easily checked by a well directed and sustained fire.

If the charge is directed against the flank of the firing line, the supports, reserves, or machine guns should stop it. If this disposition is impracticable, part of the line must meet the charge by a timely change of front. If the flank company, or companies, in the firing line execute **platoons right**, the successive firing lines can ordinarily break a charge against the flank. If the cavalry line passes through the firing line, the latter will be little damaged if the men retain their presence of mind. They should be on the watch for succeeding cavalry lines and leave those that have passed through to friendly troops in rear. (570)

593. Standing position best to meet charge. Men standing are in the best position to meet a charge, but other considerations may compel them to meet it lying prone. (571)

594. Rifle fire main dependence of infantry. In a *mêlée*, the infantryman with his bayonet has at least an even chance with the cavalryman, but the main dependence of infantry is rifle fire. Any formation is suitable that permits the free use of the necessary number of rifles.

Ordinarily there will be no time to change or set sights. Fire at will at battle sight should be used, whatever the range may be. It will usually be unwise to open fire at long ranges. (572)

595. Meeting of cavalry charge by infantry in column. An infantry column that encounters cavalry should deploy at once. If attacked from the head or rear of the column, and if time is pressing, it may form a succession of skirmish lines. Infantry, by deploying 50 or 100 yards in rear of an obstacle, may check cavalry and hold it under fire beyond effective pistol range.

In any situation, to try to escape the issue by running is the worst and most dangerous course the infantry can adopt. (573)

596. Infantry attacking dismounted cavalry. In attacking dismounted cavalry, infantry should close rapidly and endeavor to prevent remounting. Infantry which adopts this course will not be seriously checked by delaying cavalry.

Every effort should be made to locate and open fire on the led horses. (574)

[Pg 139]

INFANTRY AGAINST ARTILLERY

597. Frontal attack against artillery usually futile; use of machine guns. A frontal attack against artillery has little chance of succeeding unless it can be started from cover at comparatively short range. Beyond short range, the frontal fire of infantry has little effect against the artillery personnel because of their protective shields.

Machine guns, because their cone of fire is more compact, will have greater effect, but on the other hand they will have fewer opportunities, and they are limited to fire attack only.

As a rule, one's own artillery is the best weapon against hostile artillery. (575)

598. Flank attack against artillery effective. Artillery attacked in flank by infantry can be severely damaged. Oblique or flank fire will begin to have decisive effect when delivered at effective range from a point to one side of the artillery's line of fire and distant from it by about half the range. Artillery is better protected on the side of the caisson. (576)

599. Action against guns out of ammunition. Guns out of ammunition, but otherwise secure against infantry attack, may be immobilized by fire which will prevent their withdrawal, or by locating and driving off their limbers. Or they may be kept out of action by fire which will prevent the receipt of ammunition. (577)

600. Action against artillery limbering or coming into action; wheel horses best targets. Artillery when limbered is helpless against infantry fire. If caught at effective range while coming into action or while limbering, artillery can be severely punished by infantry fire.

In attacking artillery that is trying to escape, the wheel horses are the best targets. (578)

ARTILLERY SUPPORTS

601. Purpose of artillery support, usually consisting of infantry. The purpose of the artillery support is to guard the artillery against surprise or attack.

Artillery on the march or in action is ordinarily so placed as to be amply protected by the infantry. Infantry always protects artillery in its neighborhood. (579)

602. Detailing of supports. The detail of a support is not necessary except when the artillery is separated from the main body or occupies a position in which its flanks are not protected.

The detail of a special support will be avoided whenever possible. (580.)

603. Formation of support on march. The formation of an artillery support depends upon circumstances. On the march it may often be necessary to provide advance, flank, and rear protection. The country must be thoroughly reconnoitered by patrols within long rifle range. (581)

604. Formation and location of support in action. In action, the formation and location of the support must be such as to gain and give timely information of the enemy's approach and to offer actual resistance to the enemy beyond effective rifle range of the artillery's flanks. It should not be close enough to the artillery to suffer from fire directed at the artillery. In most cases a position somewhat to the flank and rear best fulfills these conditions. (582)

[Pg 140]

605. Support charged only with protection of artillery. The support commander is charged only with the protection of the artillery. The tactical employment of each arm rests with its commander. The two should cooperate. (583)

MINOR WARFARE

606. What minor warfare embraces; regular operations. Minor warfare embraces both regular and irregular operations.

Regular operations consist of minor actions involving small bodies of trained and organized troops on both sides.

The tactics employed are in general those prescribed for the smaller units. (596)

607. Irregular operations. Irregular operations consist of actions against unorganized or partially organized forces, acting independent or semi independent bodies. Such bodies have little or only crude training and are under nominal and loose leadership and control. They assemble, roam about, and disperse at will. They endeavor to win by stealth or by force of superior numbers, employing ambushes, sudden dashes or rushes, and hand-to-hand fighting. (597)

Troops operating against such an enemy usually do so in small units, such as platoons, detachments, or companies, and the tactics employed must be adapted to meet the requirements of the situation. Frequently the enemy's own methods may be employed to advantage.

In general, such operations should not be undertaken hastily; every preparation should be made to strike suddenly and to inflict the maximum punishment.

608. March and bivouac formations to admit of rapid action in any direction. In general, the service of information will be insufficient; adequate reconnaissance will rarely be practicable. March and bivouac formations must be such as to admit of rapid deployment and fire action in any direction. (598)

609. Formation in open country. In the open country, where surprise is not probable, troops may be marched in column of squads preceded, within sight, by a squad as an advance party. (599)

610. Formation in close country. In close country, where surprise is possible, the troops must be held in a close formation. The use of flank patrols becomes difficult. Occasionally, an advance party—never less than a squad—may be sent out. In general, however, such a party accomplishes

little, since an enemy intent on surprise will permit it to pass unmolested and will fall upon the main body.

Under such conditions, especially when the road or trail is narrow, the column of twos or files is a convenient formation, the officers placing themselves in the column so as to divide it into nearly equal parts. If rushed from a flank, such a column will be in readiness to face and fire toward either or both flanks, the ranks being back to back; if rushed from the front, the head of the column may be deployed, the rest of the column closing up to support it and to protect its flanks and rear. In any event, the men should be taught to take some form of a closed back to back formation. (600)

[Pg 141]

611. Dividing column on march into two or more separate detachments. The column may often be broken into two or more approximately equal detachments separated on the march by distances of 50 to 100 yards. As a rule the detachments should not consist of less than 25 men each. With this arrangement of the column, it will rarely be possible for an enemy to close simultaneously with all of the detachments, one or more being left unengaged and under control to support those engaged or to inflict severe punishment upon the enemy when he is repulsed. (601)

612. Selection of site for camp or bivouac; protection. The site for camp or bivouac should be selected with special reference to economical and effective protection against surprise. Double sentinels are posted on the avenues of approach, and the troops sleep in readiness for instant action. When practicable, troops should be instructed in advance as to what they are to do in case of attack at night. (602)

613. Night operations frequently advisable. Night operations are frequently advisable. With the small forces employed, control is not difficult. Irregular troops rarely provide proper camp protection, and they may frequently be surprised and severely punished by a properly conducted night march and attack. (603)

CEREMONIES

General Rules for Ceremonies

614. Order in which troops are arranged for ceremonies; commander faces command; subordinates face to front. The order in which the troops of the various arms are arranged for ceremonies is prescribed by Army Regulations.

When forming for ceremonies the companies of the battalion and the battalions of the regiment are posted from right to left in line and from head to rear in column, in the order of rank of their respective commanders present in the formation, the senior on the right or at the head.

The commander faces the command; subordinate commanders face to the front. (708)

615. Saluting by lieutenant colonel and staffs. At the command present arms, given by the colonel, the lieutenant colonel, and the colonel's staff salute; the major's staff salute at the major's command. Each staff returns to the carry or order when the command **order arms** is given by its chief. (709)

616. Formation of companies, battalion and regiment. At the **assembly** for a ceremony companies are formed on their own parades and informally inspected, as prescribed in [par. 646](#).

At **adjutant's call**, except for ceremonies involving a single battalion, each battalion is formed on its own parade, reports are received, and the battalion presented to the major, as laid down in [par. 308](#). At the second sounding of adjutant's call the regiment is formed. (710)

[Pg 142]

REVIEWS

General Rules

617. Indication of points where column changes direction; flank to pass 12 paces from reviewing officer; post of reviewing officer and others. The adjutant posts men or otherwise marks the points where the column changes direction in such manner that its flank in passing will be about 12 paces from the reviewing officer.

The post of the reviewing officer, usually opposite the center of the line, is indicated by a marker.

Officers of the same or higher grade, and distinguished personages invited to accompany the reviewing officer, place themselves on his left; their staffs and orderlies place themselves respectively on the left of the staff and orderlies of the reviewing officer; all others who accompany the reviewing officer place themselves on the left of his staff, their orderlies in rear. A staff officer is designated to escort distinguished personages and to indicate to them their proper

positions, as prescribed in [par. 73](#). (711)

618. Riding around the troops; saluting the color; reviewing officer returns only salute of commanding officer of troops. While riding around the troops, the reviewing officer may direct his staff, flag and orderlies to remain at the post of the reviewing officer, or that only his personal staff and flag shall accompany him; in either case the commanding officer alone accompanies the reviewing officer. If the reviewing officer is accompanied by his entire staff, the staff officers of the commander place themselves on the right of the staff of the reviewing officer.

The reviewing officer and others at the reviewing stand salute the color as it passes; when passing around the troops, the reviewing officer and those accompanying him salute the color when passing in front of it.

The reviewing officer returns the salute of the commanding officer of the troops only. Those who accompany the reviewing officer do not salute. (712)

619. Saluting by staffs. In passing in review, each staff salutes with its commander. (713)

620. Turning out of column by commanding officer of troops and staff. After saluting the reviewing officer, the commanding officer of the troops turns out of the column, takes post on the right of the reviewing officer, and returns saber; the members of his staff accompanying him take post on the right of the reviewing officer's staff and return saber. When the rear element of his command has passed, without changing his position, the commanding officer of the troops salutes the reviewing officer; he and the members of his staff accompanying him then draw saber and rejoin his command. The commanding officer of the troops and the members of his staff are the only ones who turn out of the column. (714)

621. Turning out of column by commanding officer of troops and staff. If the person reviewing the command is not mounted, the commanding officer and his staff on turning out of the column after passing the reviewing officer dismount preparatory to taking post. In such case, the salute of the commanding officer, prior to rejoining his command, is made with the hand before remounting. (715)

[Pg 143]

622. Salute by regimental color. When the rank of the reviewing officer entitles him to the honor, each regimental color salutes at the command **present arms**, given or repeated by the major of the battalion with which it is posted; and again in passing in review. (716)

623. The band. The band of an organization plays while the reviewing officer is passing in front of and in rear of the organization.

Each band, immediately after passing the reviewing officer, turns out of the column, takes post in front of and facing him, continues to play until its regiment has passed, then ceases playing and follows in rear of its regiment; the band of the following regiment commences to play as soon as the preceding band has ceased.

While marching in review but one band in each brigade plays at a time, and but one band at a time when within 100 paces of the reviewing officer. (717)

624. The national air, to the color, march, flourishes or ruffles,—when played. If the rank of the reviewing officer entitles him to the honor, the band plays the prescribed **national air**, or the field music sounds **to the color, march, flourishes** or **ruffles** when arms are presented. When passing in review at the moment the regimental color salutes, the musicians halted in front of the reviewing officer, sound **to the color, march, flourishes** or **ruffles**. (718)

625. Modifications of the review. The formation for review may be modified to suit the ground, and the **present arms** and the ride around the line by the reviewing officer may be dispensed with. (719)

626. When post of reviewing officer is on left of column. If the post of the reviewing officer is on the left of the column, the troops march in review with the guide left; the commanding officer and his staff turn out of the column to the left, taking post as prescribed above, but to the left of the reviewing officer; in saluting, the captains give the command: **1. Eyes, 2. LEFT**. (720)

627. Cadence at which troops pass in review. Except in the review of a single battalion, the troops pass in review in quick time only. (721)

628. Reviews of brigades or larger commands; action of battalions after passing reviewing officer. In reviews of brigades or larger commands, each battalion, after the rear has passed the reviewing officer 50 paces, takes the double time for 100 yards in order not to interfere with the march of the column in rear; if necessary, it then turns out of the column and returns to camp by the most practicable route; the leading battalion of each regiment is followed by the other units of the regiment. (722)

629. Standing "at ease," "rest," etc., in review of brigade or larger command. In a brigade or larger review a regimental commander may cause his regiment to stand **at ease, rest,** or **stack arms** and **fall out** and **resume attention**, so as not to interfere with the ceremony. (723)

630. Review by inspector junior to commanding officer. When an organization is to be reviewed before an inspector junior in rank to the commanding officer, the commanding officer receives the review and is accompanied by the inspector, who takes post on his left. (724)

[Pg 144]

Battalion Review

631. Presenting battalion to reviewing officer; passing around battalion; battalion passing in review at quick time. The battalion having been formed in line, the major faces to the front; the reviewing officer moves a few paces toward the major and halts; the major turns about and commands: **1. Present, 2. ARMS**, and again turns about and salutes.

The reviewing officer returns the salute; the major turns about, brings the battalion to order arms, and again turns to the front.

The reviewing officer approaches to about 6 paces from the major, the latter salutes, takes post on his right, and accompanies him around, the battalion. The band plays. The reviewing officer proceeds to the right of the band, passes in front of the captain to the left of the line and returns to the right, passing in rear of the file closers and the band. (See [par. 625.](#))

On arriving again at the right of the line, the major salutes, halts, and when the reviewing officer and staff have passed, moves directly to his post in front of the battalion, faces it, and commands: **1. Pass in review, 2. Squads right, 3. MARCH.**

At the first command the band changes direction if necessary, and halts.

At the third command, given when the band has changed direction, the battalion moves off, the band playing; without command from the major the column changes direction at the points indicated, and column of companies at full distance is formed successively to the left at the second change of direction; the major takes his post 20 paces in front of the band immediately after the second change; the band having passed the reviewing officer, turns to the left of the column, takes post in front of and facing the reviewing officer, and remains there until the review terminates.

The major and staff salute, turn the head as in **eyes right**, and look toward the reviewing officer when the major is 6 paces from him; they return to the carry and turn the head and eyes to the front when the major has passed 6 paces beyond him.

Without facing about, each captain or special unit commander, except the drum major, commands: **1. Eyes**, in time to add, **2. RIGHT**, when at 6 paces from the reviewing officer, and commands **front** when at 6 paces beyond him. At the command **eyes** the company officers armed with the saber execute the first motion of present saber; at the command **right** all turn head and eyes to the right, the company officers complete **present saber**, and the noncommissioned officers armed with the saber execute the first motion of present saber; at the command **front** all turn head and eyes to the front, and officers and noncommissioned officers armed with the saber resume the carry saber; without arms in hand, the first motion of the hand salute is made at the command **right**, and the second motion not made until the command **front**.

Noncommissioned staff officers, noncommissioned officers in command of subdivisions, and the drum major salute, turn the head and eyes, return to the front, resume the carry or drop the hand, at the points prescribed for the major. Officers and dismounted noncommissioned officers in command of subdivisions, with arms in hand, render the rifle or saber salute. Guides charged with the step, trace, and direction do not execute **eyes right**.

[Pg 145]

If the reviewing officer is entitled to a salute from the color the regimental color salutes when at 6 paces from him, and is raised when at 6 paces beyond him.

The major, having saluted, takes post on the right of the reviewing officer, returns saber and remains there until the rear of the battalion has passed, then salutes and rejoins his battalion. The band ceases to play when the column has completed its second change of direction after passing the reviewing officer. (725)

632. Passing in review at double time. When the battalion arrives at its original position in column, the major commands: **1. Double time, 2. MARCH.**

The band plays in double time.

The battalion passes in review as before, except that in double time the command **eyes right** is omitted and there is no saluting except by the major when he leaves the reviewing officer.

The review terminates when the rear company has passed the reviewing officer: the band then ceases to play, and, unless otherwise directed by the major, returns to the position it occupied before marching in review, or is dismissed; the major rejoins the battalion and brings it to **quick time**. The battalion then executes such movements as the reviewing officer may have directed, or is marched to its parade ground and dismissed.

Marching past in double time may, in the discretion of the reviewing officer, be omitted; the review terminates when the major rejoins his battalion. (726)

633. Major and staff may be dismounted. At battalion review the major and his staff may be dismounted in the discretion of the commanding officer. (727)

PARADES

General Rules

634. Position assumed by reviewing officer and staff while band is sounding off. If dismounted, the officer reviewing the parade, and his staff, stand at parade rest, with arms folded, while the band is sounding off; they resume attention with the adjutant. If mounted, they remain at attention. (732)

635. Reports by captains and majors. At the command **report**, given by a battalion adjutant, the captains in succession from the right salute and report: **A (or other) company, present or accounted for;** or **A (or other) company, (so many) officers or enlisted men absent**, and resume the order saber; at the same command given by the regimental adjutant, the majors similarly **report** their battalions. (733)

[Pg 146]

Battalion Parade

636. At adjutant's call the battalion is formed in line, as explained in [par. 308](#), but not presented. Lieutenants take their posts in front of the center of their respective platoons at the captain's command for dressing his company on the line, as explained in [par. 302](#). The major takes post at a convenient distance in front of the center and facing the battalion.

The adjutant from his post in front of the center of the battalion, after commanding: **1. Guides, 2. POSTS**, adds: **1. Parade, 2. REST**; the battalion executes parade rest. The adjutant directs the band: **SOUND OFF**.

The band, playing in quick time, passes in front of the line of officers to the left of the line and back to its post on the right, when it ceases playing. At evening parade, when the band ceases playing, **retreat** is sounded by the field music and, following the last note and while the flag is being lowered, the band plays the **Star Spangled Banner**.

Just before the last note of retreat, the adjutant comes to attention and, as the last note ends commands: **1. Battalion, 2. Attention, 3. Present, 4. Arms**, and salutes retaining that position until the last note of the National Anthem. He then turns about and reports: **Sir, the parade is formed**. The major directs the adjutant: **Take your post, Sir**. The adjutant moves at a trot (if dismounted, in quick time), passes by the major's right, and takes his post.

The major draws saber and commands: **1. Order, 2. ARMS**, and adds such exercises in the manual of arms as he may desire. Officers, noncommissioned officers commanding companies or armed with the saber, and the color guard, having once executed order arms, remain in that position during the exercises in the manual.

The major then directs the adjutant: **Receive the reports, Sir**. The adjutant, passing by the major's right, advances at a trot (if dismounted, in quick time) toward the center of the line, halts midway between it and the major, and commands: **REPORT**. (See [par. 635](#).)

The reports received, the adjutant turns about, and reports: **Sir, all are present or accounted for;** or **Sir, (so many) officers or enlisted men are absent**, including in the list of absentees those from the band and field music reported to him by the drum major prior to the parade.

The major directs: **Publish the orders, Sir**.

The adjutant turns about and commands: **Attention to orders**; he then reads the orders, and commands: **1. Officers, 2. CENTER, 3. MARCH**.

At the command **center**, the company officers carry saber and face to the center. At the command **march**, they close to the center and face to the front; the adjutant turns about and takes his post.

The officers having closed and faced to the front, the senior commands: **1. Forward, 2. MARCH**. The officers advance, the band playing; the left officer of the center or right center company is the guide, and marches on the major; the officers are halted at 6 paces from the major by the senior, who commands: **1. Officers, 2. HALT**. They halt and salute, returning to the carry saber with the major. The major then gives such instructions as he deems necessary, and commands: **1. Officers, 2. POSTS, 3. MARCH**.

At the command **march**, they step off with guide as before, and the senior commands: **1. Officers, 2. HALT**, so as to halt 3 paces from the line; he then adds: **1. POSTS, 2. MARCH**.

At the command **posts**, officers face outward and, at the command **march**, step off in succession at 4 paces distance, resume their posts and order saber; the lieutenants march directly to their posts in rear of their companies.

The music ceases when all officers have resumed their posts.

The major then commands: **1. Pass in review, 2. Squads right, 3. MARCH**, and returns saber.

The battalion marches according to the principles of review; when the last company has passed, the ceremony is concluded, as explained in [pars. 617; 631](#).

The band continues to play while the companies are in march upon the parade ground. Companies are formed in column of squads, without halting, and are marched to their respective parades by their captains.

When the company officers have saluted the major, he may direct them to form line with the staff, in which case they individually move to the front, passing to the right and left of the major and staff, halt on the line established by the staff, face about, and stand at attention. The music ceases when the officers join the staff. The major causes the companies to pass in review under the command of their first sergeants by the same commands as before. The company officers return saber with the major and remain at attention. (734)

ESCORTS

Escort of the Color

637. By a company. The regiment being in line or line of masses, the colonel details a company, other than the color company, to receive and escort the national color to its place. During the ceremony the regimental color remains with the color guard at its post with the regiment.

The band moves straight to its front until clear of the line of field officers, changes direction to the right, and is halted; the designated company forms column of platoons in rear of the band, the color bearer or bearers between the platoons.

The escort then marches without music to the colonel's office or quarters and is formed in line facing the entrance, the band on the right, the color bearer in the line of file closers.

The color bearer, preceded by the first lieutenant and followed by a sergeant of the escort, then goes to obtain the color.

When the color bearer comes out, followed by the lieutenant and sergeant, he halts before the entrance, facing the escort; the lieutenant places himself on the right, the sergeant on the left of the color bearer; the escort presents arms, and the field music sounds **to the color**; the first lieutenant and sergeant salute.

Arms are brought to the order; the lieutenant and sergeant return to their posts; the company is formed in column of platoons, the band taking post in front of the column; the color bearer places himself between the platoons; the escort marches in quick time, with guide left, back to the regiment, the band playing; the march is so conducted that when the escort arrives at 50 paces in front of the right of the regiment, the direction of the march shall be parallel to its front; when the color arrives opposite its place in line, the escort is formed in line to the left; the color bearer, passing between the platoons, advances and halts 12 paces in front of the colonel.

The color bearer having halted, the colonel, who has taken post 30 paces in front of the center of the regiment, faces about, commands: **1. Present, 2. ARMS**, resumes his front, and salutes; the field music sounds to the color; and the regimental color bearer executes the color salute at the command **present arms**.

The colonel then faces about, brings the regiment to the order, at which the color bearer resumes the carry and takes his post with the color company.

The escort presents arms and comes to the order with the regiment, at the command of the colonel, after which the captain forms it again in column of platoons, and, preceded by the band, marches it to its place, passing around the left flank of the regiment.

The band plays until the escort passes the left of the line, when it ceases playing and returns to its post on the right, passing in rear of the regiment.

The regiment may be brought to a rest when the escort passes the left of the line. (736)

638. By a battalion. Escort of the color is executed by a battalion according to the same principles. (737)

Escorts of Honor

639. Escorts of honor are detailed for the purpose of receiving and escorting personages of high rank, civil or military. The troops for this purpose are selected for their soldierly appearance and superior discipline.

The escort forms in line, opposite the place where the personage presents himself, the band on the flank of the escort toward which it will march. On the appearance of the personage, he is received with the honors due to his rank. The escort is formed into column of companies, platoons or squads, and takes up the march, the personage and his staff or retinue taking positions in rear of the column; when he leaves the escort, line is formed and the same honors are paid as before.

When the position of the escort is at a considerable distance from the point where the personage is to be received, as for instance, where a courtyard or wharf intervenes, a double line of sentinels is posted from that point to the escort, facing inward; the sentinels successively salute as he passes and are then relieved and join the escort.

An officer is appointed to attend him and bear such communication as he may have to make to the commander of the escort. (738)

[Pg 149]

Funeral Escort

640. Composition and strength, formation, presenting arms, marching, etc. The composition and strength of the escort are prescribed in Army Regulations.

The escort is formed opposite the quarters of the deceased; the band on that flank of the escort toward which it is to march.

Upon the appearance of the coffin, the commander commands: **1. Present, 2. ARMS**, and the band plays an appropriate air; arms are then brought to the order.

The escort is next formed into column of companies, platoons, or squads. If the escort be small, it may be marched in line. The procession is formed in the following order: **1. Music, 2. Escort, 3. Clergy, 4. Coffin and pallbearers, 5. Mourners, 6. Members of the former command of the deceased, 7. Other officers and enlisted men, 8. Distinguished persons, 9. Delegations, 10. Societies, 11. Civilians.** Officers and enlisted men (Nos. 6 and 7), with side arms, are in the order of rank, seniors in front.

The procession being formed, the commander of the escort puts it in march.

The escort marches slowly to solemn music; the column having arrived opposite the grave, line is formed facing it.

The coffin is then carried along the front of the escort to the grave; arms are presented, the music plays an appropriate air; the coffin having been placed over the grave, the music ceases and arms are brought to the order.

The commander next commands: **1. Parade, 2. REST.** The escort executes **parade rest**, officers and men inclining the head.

When the funeral services are completed and the coffin lowered into the grave, the commander causes the escort to resume attention and fire three rounds of blank cartridges, the muzzles of the pieces being elevated. When the escort is greater than a battalion, one battalion is designated to fire the volley.

A musician then sounds **taps**.

The escort is then formed into column, marched in quick time to the point where it was assembled, and dismissed.

The band does not play until it has left the inclosure.

When the distance to the place of interment is considerable, the escort, after having left the camp or garrison, may march **at ease** in quick time until it approaches the burial ground, when it is brought to attention. The music does not play while marching **at ease**.

In marching at attention, the field music may alternate with the band in playing. (739)

641. Funeral of general officer; playing national air, sounding ruffles, etc., as honor.

When arms are presented at the funeral of a person entitled to any of the following honors, the band plays the prescribed **national air**, or the field music sounds to the **color, march, flourishes**, or **ruffles**, according to the rank of the deceased, after which the band plays an appropriate air. The commander of the escort, in forming column, gives the appropriate commands for the different arms. (740)

642. Funeral of mounted officer or soldier. At the funeral of a mounted officer or enlisted man, his horse, in mourning caparison, follows the hearse. (741)

[Pg 150]

643. When hearse, cavalry, and artillery are unable to enter cemetery. Should the entrance of the cemetery prevent the hearse accompanying the escort till the latter halts at the grave, the column is halted at the entrance long enough to take the coffin from the hearse, when the column is again put in march. The Cavalry and Artillery, when unable to enter the inclosure, turn out of the column, face the column, and salute the remains as they pass. (742)

644. Escorting remains from quarters to church before funeral services. When necessary to escort the remains from the quarters of the deceased to the church before the funeral service, arms are presented upon receiving the remains at the quarters and also as they are borne into the church. (743)

645. Instructions to clergyman and pallbearers. The commander of the escort, previous to the funeral, gives the clergyman and pallbearers all needful directions. (744)

Company Inspection

646. Being in line at a halt: **1. Open ranks, 2. MARCH.**

At the command **march** the front rank executes **right dress**; the rear rank and the file closers march backward 4 steps, halt, and execute right dress; the lieutenants pass around their respective flanks and take post, facing to the front, 3 paces in front of the center of their respective platoons. The captain aligns the front rank, rear rank, and file closers, takes post 3 paces in front of the right guide, facing to the left, and commands: **1. FRONT, 2. PREPARE FOR INSPECTION.**

At the second command the lieutenants carry saber; the captain returns saber and inspects them, after which they face about, order saber, and stand at ease; upon the completion of the inspection they carry saber, face about, and order saber. The captain may direct the lieutenants to accompany or assist him, in which case they return saber and, at the close of the inspection, resume their posts in front of the company, draw and carry saber.

Having inspected the lieutenants, the captain proceeds to the right of the company. Each man, as the captain approaches him, executes **inspection arms**.

The captain takes the piece, grasping it with his right hand just above the rear sight, the man dropping his hands. The captain inspects the piece, and, with the hand and piece in the same position as in receiving it, hands it back to the man, who takes it with the left hand at the balance and executes **order arms**.

As the captain returns the piece, the next man executes **inspection arms**, and so on through the company.

Should the piece be inspected without handling, each man executes **order arms** as soon as the captain passes to the next man.

[Pg 151]

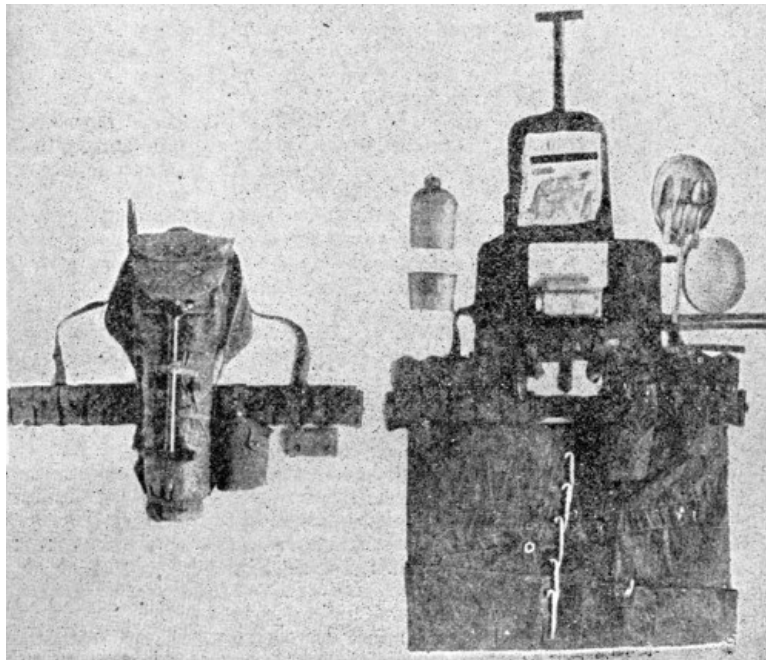

Plate VI.

The inspection is from right to left in front, and from left to right in the rear, of each rank and of the line of file closers.

When approached by the captain, the first sergeant executes **inspection saber**. Enlisted men armed with the pistol execute **inspection pistol** by drawing the pistol from the holster and holding it diagonally across the body, barrel up, and 6 inches in front of the neck, muzzle pointing up and to the left. The pistol is returned to the holster as soon as the captain passes.

Upon completion of the inspection, the captain takes post facing to the left in front of the right guide and on line with the lieutenants and commands: **1. Close ranks, 2. MARCH.**

At the command **march** the lieutenants resume their posts in line; the rear rank closes to 40 inches, each man covering his file leader; the file closers close to 2 paces from the rear rank. (745)

647. Inspection of quarters or camp. If the company is dismissed, rifles are put away. In quarters, headdress and accouterments are removed, and the men stand near their respective bunks; in camp, they stand covered, but without accouterments, in front of their tents.

[Pg 152]

If the personal field equipment has not been inspected in ranks and its inspection in quarters or camp is ordered, each man will arrange the prescribed articles on his bunk, if in quarters or permanent camp, or in front of his half of the tent, if in shelter tent camp, in the same relative order as directed in [paragraph 648](#).

The captain, accompanied by the lieutenants, then inspects the quarters or camp. The first sergeant precedes the captain and calls the men to attention on entering each squad room or on approaching the tents; the men stand at attention, but do not salute. (746)

648. When inspection includes examination of equipment. If the inspection is to include an examination of the equipment while in ranks, the captain, after closing ranks, causes the company to stack arms, to march backward until 4 paces in rear of the stacks and to take intervals. He then commands:

1. UNSLING EQUIPMENT, 2. OPEN PACKS.

At the first command each man unslings his equipment and places it on the ground at his feet, haversack to the front, end of the pack 1 foot in front of toes.

At the second command, pack carriers are unstrapped, packs removed and unrolled, the longer edge of the pack along the lower edge of the cartridge belt. Each man exposes shelter-tent pins; removes meat can, knife, fork, and spoon from the meat-can pouch, and places them on the right of the haversack, knife, fork, and spoon in the open meat can; removes the canteen and cup from the cover and places them on the left side of the haversack; unstraps and spreads out haversack so as to expose its contents; folds up the carrier to uncover the cartridge pockets; opens same; unrolls toilet articles and places them on the outer flap of the haversack; places underwear carried in pack on the left half of the open pack, with round fold parallel with front edge of pack; opens first-aid pouch and exposes contents to view. Special articles carried by individual men, such as flag kit, field glasses, compass, steel tape, notebook, etc., will be arranged on the right half of the open pack. Each man then resumes the attention. [Plate VI](#) (Page 151) shows the relative position of all articles except underwear and special articles.

The captain then passes along the ranks and file closers, as before, inspects the equipment,

returns to the right, and commands: **CLOSE PACKS**.

Each man rolls up his toilet articles and underwear, straps up his haversack and its contents, replaces the meat can, knife, fork, and spoon, and the canteen and cup; closes cartridge pockets and first-aid pouch; restores special articles to their proper receptacles; rolls up and replaces pack in carrier, and, leaving the equipment in its position on the ground, resumes the attention.

All equipments being packed, the captain commands: **SLING EQUIPMENT**.

The equipments are slung and belts fastened.

The captain then causes the company to assemble and take arms. The inspection is completed as already explained. (747)

649. When the inspector is other than the captain. Should the inspector be other than the captain, the latter, after commanding **front**, adds **REST**, and faces to the front. When the inspector approaches, the captain faces to the left, brings the company to attention, faces to the front, and salutes. The salute acknowledged, the captain carries saber, faces to the left, commands: **PREPARE FOR INSPECTION**, and again faces to the front.

[Pg 153]

The inspection proceeds as before; the captain returns saber and accompanies the inspector as soon as the latter passes him. (748)

Battalion Inspection

650. Inspection may precede or follow review; the inspection up to time the companies are inspected. If there be both inspection and review, the inspection may either precede or follow the review.

The battalion being in column of companies at full distance, all officers dismounted, the major commands: **1. Prepare for inspection, 2. MARCH**.

At the first command each captain commands: **Open ranks**.

At the command **march** the ranks are opened in each company, as in the inspection of the company, as prescribed in [par. 646](#).

The field musicians join their companies.

The drum major conducts the band to a position 30 paces in rear of the column, if not already there, and opens ranks.

The major takes post facing to the front and 20 paces in front of the center of the leading company. The staff takes post as if mounted. The color takes post 5 paces in rear of the staff.

Field and staff officers senior in rank to the inspector do not take post in front of the column, but accompany him.

The inspector inspects the major, and, accompanied by the latter, inspects the staff officers.

The major then commands: **REST**, returns saber, and, with his staff, accompanies the inspector.

If the major is the inspector he commands: **REST**, returns saber, and inspects his staff, which then accompanies him.

The inspector, commencing at the head of the column, then makes a minute inspection of the color guard, the noncommissioned staff, and the arms, accouterments, dress and ammunition of each soldier of the several companies in succession, and inspects the band.

The adjutant gives the necessary commands for the inspection of the color guard, noncommissioned staff, and band.

The color guard and noncommissioned staff may be dismissed as soon as inspected. (749)

651. Inspection of the companies. As the inspector approaches each company, its captain commands: **1. Company, 2. ATTENTION, 3. PREPARE FOR INSPECTION**, and faces to the front; as soon as inspected he returns saber and accompanies the inspector. The inspection proceeds as in company inspection, as explained in [pars. 646-649](#). At its completion the captain closes ranks and commands: **REST**. Unless otherwise directed by the inspector, the major directs that the company be marched to its parade and dismissed. (750)

652. When inspection lasts long time. If the inspection will probably last a long time the rear companies may be permitted to stack arms and fall out; before the inspector approaches, they fall in and take arms. (751)

[Pg 154]

653. The band. The band plays during the inspection of the companies.

When the inspector approaches the band the adjutant commands: **PREPARE FOR INSPECTION.**

As the inspector approaches him each man raises his instrument in front of the body, reverses it so as to show both sides, and then returns it.

Company musicians execute inspection similarly. (752)

654. Inspection of quarters or camp. At the inspection of quarters or camp the inspector is accompanied by the captain, followed by the other officers or by such of them as he may designate. The inspection is conducted as described in the company inspection, as laid down in [pars. 646-649](#).

MUSTER

Regimental, Battalion, or Company Muster

655. Inspection and review; muster rolls; lists of absentees. Muster is preceded by an inspection, and, when practicable, by a review.

The adjutant is provided with the muster roll of the field, staff, and band, the surgeon with the hospital roll; each captain with the roll of his company. A list of absentees, alphabetically arranged, showing cause and place of absence, accompanies each roll. (755)

656. Calling the names; verifying presence of absentees. Being in column of companies at open ranks, each captain, as the mustering officer approaches, brings his company to right shoulder arms, and commands: **ATTENTION TO MUSTER.**

The mustering officer or captain then calls the names on the roll; each man, as his name is called, answers **Here** and brings his piece to order arms.

After muster, the mustering officer, accompanied by the company commanders and such other officers as he may designate, verifies the presence of the men reported in hospital, on guard, etc. (756)

657. Muster of company on company parade. A company may be mustered in the same manner on its own parade ground, the muster to follow the company inspection. (757)

THE COLOR

658. Meaning of "Color;" Army Regulations. The word "color" implies the national color; it includes the regimental color when both are present.

The rules prescribing the colors to be carried by regiments and battalions on all occasions are contained in Army Regulations. (766)

659. Where the colors are kept; "cased" defined. In garrison the colors, when not in use, are kept in the office or quarters of the colonel, and are escorted thereto and therefrom by the color guard. In camp the colors, when not in use, are in front of the colonel's tent. From reveille to retreat, when the weather permits, they are displayed uncased; from retreat to reveille and during inclement weather they are cased.

[Pg 155]

Colors are said to be cased when furled and protected by the oil cloth covering. (767)

660. Regimental and national colors—salutes by. The regimental color salutes in the ceremony of escort of the color, and when saluting an officer entitled to the honor, but in no other case.

If marching, the salute is executed when at 6 paces from the officer entitled to the salute; the carry is resumed when 6 paces beyond him.

The national color renders no salute. (768)

The Color Guard

661. Composition of color guard; carrying of regimental and national colors. The color guard consists of two color sergeants, who are the color bearers, and two experienced privates selected by the colonel. The senior color sergeant carries the national color; the junior color sergeant carries the regimental color. The regimental color, when carried, is always on the left of

the national color, in whatever direction they may face. (769)

662. Formation and marching of color guard. The color guard is formed and marched in one rank, the color bearers in the center. It is marched in the same manner and by the same commands as a squad, substituting, when necessary, guard for squad. (770)

663. Color company defined; color guard remains with it. The color company is the center or right center company of the center or right center battalion. The color guard remains with that company unless otherwise directed. (771)

664. Post of color guard in various formations. In line, the color guard is in the interval between the inner guides of the right and left center companies.

In line of columns or in close line, the color guard is midway between the right and left center companies and on line with the captains.

In column of companies or platoons, the color guard is midway between the color company and the company in rear of the color company and equidistant from the flanks of the column.

In close column, the color guard is on the flank of the color company.

In column of squads, the color guard is in the column between the color company and the company originally on its left.

When the regiment is formed in line of masses for ceremonies, the color guard forms on the left of the leading company of the center (right center) battalion. It rejoins the color company when the regiment changes from line of masses. (772)

665. In battle color guard joins reserve. The color guard, when with a battalion that takes the battle formation, joins the regimental reserve, whose commander directs the color guard to join a certain company of the reserve. (773)

666. Loadings, firings, manual of arms, and movements by color guard. The color guard executes neither loadings nor firings; in rendering honors, it executes all movements in the manual; in drill, all movements unless specially excused. (774)

[Pg 156]

To Receive the Color

667. Receiving the color by color guard. The color guard, by command of the senior color sergeant, presents arms on receiving and parting with the color. After parting with the color, the color guard is brought to order arms by command of the senior member, who is placed as the right man of the guard. (775)

668. Receiving the color by color company. At drills and ceremonies, excepting escort of the color, the color, if present, is received by the color company after its formation.

The formation of the color company completed, the captain faces to the front; the color guard, conducted by the senior sergeant, approaches from the front and halts at a distance of 10 paces from the captain, who then faces about, brings the company to the **present**, faces to the front, salutes, again faces about and brings the company to the **order**. The color guard comes to the **present** and **order** at the command of the captain, and is then marched by the color sergeant directly to its post on the left of the color company. (776)

669. Escorting color to office or quarters of colonel. When the battalion is dismissed the color guard escorts the color to the office or quarters of the colonel. (777)

Manual of the Color

670. At the **carry**, the heel of the pike rests in the socket of the sling; the right hand grasps the pike at the height of the shoulder.

At the **order**, the heel of the pike rests on the ground near the right toe, the right hand holding the pike in a vertical position.

At **parade rest**, the heel of the pike is on the ground, as at the **order**; the pike is held with both hands in front of the center of the body, left hand uppermost.

The **order** is resumed at the command **attention**.

The left hand assists the right when necessary.

The **carry** is the habitual position when the troops are at a shoulder, port, or trail.

The **order** and **parade rest** are executed with the troops.

The color salute: Being at a carry, slip the right hand up the pike to the height of the eye, then lower the pike by straightening the arm to the front. (778)

Manual of the Saber

671. Drawing saber; position of carry saber dismounted; unhooking scabbard before mounting; on foot carrying scabbard hooked up.

1. Draw, 2. SABER.

At the command **draw**, unhook the saber with the thumb and first two fingers of the left hand, thumb on the end of the hook, fingers lifting the upper ring; grasp the scabbard with the left hand at the upper band, bring the hilt a little forward, seize the grip with the right hand, and draw the blade 6 inches out of the scabbard, pressing the scabbard against the thigh with the left hand.

[Pg 157]

At the command **saber**, draw the saber quickly, raising the arm to its full extent, to the right front, at an angle of about 45° with the horizontal, the saber, edge down, in a straight line with the arm; make a slight pause and bring the back of the blade against the shoulder, edge to the front, arm nearly extended, hand by the side, elbow back, third and fourth fingers back of the grip; at the same time hook up the scabbard with the thumb and first two fingers of the left hand, thumb through the upper ring, fingers supporting it; drop the left hand by the side.

This is the position of carry saber dismounted.

Officers and noncommissioned officers armed with the saber unhook the scabbard before mounting; when mounted, in the first motion of **draw saber** they reach with the right hand over the bridle hand and without the aid of the bridle hand draw the saber as before; the right hand at the carry rests on the right thigh.

On foot the scabbard is carried hooked up. (782)

672. Holding of saber in publishing orders, etc.; use of saber knot. When publishing orders, calling the roll, etc., the saber is held suspended from the right wrist by the saber knot; when the saber knot is used it is placed on the wrist before drawing saber and taken off after returning saber. (783)

673. Presenting saber from carry or order; execution of the salute in rendering honors.

Being at the order or carry: **1. Present, 2. SABER** (or **ARMS**).

At the command **present**, raise and carry the saber to the front, base of the hilt as high as the chin and 6 inches in front of the neck, edge to the left, point 6 inches farther to the front than the hilt, thumb extended on the left of the grip, all fingers grasping the grip.

At the command **saber**, or **arms**, lower the saber, point in prolongation of the right foot and near the ground, edge to the left, hand by the side, thumb on left of grip, arm extended. If mounted, the hand is held behind the thigh, point a little to the right and front of the stirrup.

In rendering honors with troops, officers execute the first motion of the salute at the command **present**, the second motion at the command **arms**; enlisted men with the saber execute the first motion at the command **arms** and omit the second motion. (784)

674. Coming to order from carry; executing order or carry from present, depending upon command; coming to order saber when arms are brought to order.

Being at a carry: **1. Order, 2. SABER** (or **ARMS**).

Drop the point of the saber directly to the front, point on or near the ground, edge down, thumb on back of grip.

Being at the **present saber**, should the next command be **order arms**, officers and noncommissioned officers armed with the saber **order saber**; if the command be other than **order arms**, they execute **carry saber**.

When arms are brought to the order, the officers or enlisted men with saber drawn **order saber**. (785)

[Pg 158]

675. Position of saber in giving commands, etc.; bringing saber to carry from order. The saber is held at the carry while giving commands, marching at attention, or changing position in quick time.

When at the order, sabers are brought to the carry when arms are brought to any position except the **present** or **parade rest**. (786)

676. Parade rest from order. Being at the order: **1. Parade, 2. REST.**

Take the position of parade rest except that the left hand is uppermost and rests on the right hand, point of saber on or near the ground in front of the center of the body, edge to the right.

At the command **attention**, resume the order saber and the position of the soldier. (787)

677. Position of saber at double time. In marching in double time the saber is carried diagonally across the breast, edge to the front; the left hand steadies the scabbard. (788)

678. On duty under arms sabers to be drawn and returned without command; commands given with saber drawn. Officers and noncommissioned officers armed with the saber, on all duties under arms draw and return saber without waiting for command. All commands to soldiers under arms are given with the saber drawn. (789)

679. Returning saber from carry. Being at a carry: **1. Return, 2. SABER.**

At the command **return**, carry the right hand opposite to and 6 inches from the left shoulder, saber vertical, edge to the left; at the same time unhook and lower the scabbard with the left hand and grasp it at the upper band.

At the command **saber** drop the point to the rear and pass the blade across and along the left arm; turn the head slightly to the left, fixing the eyes on the opening of the scabbard, raise the right hand, insert and return the blade; free the wrist from the saber knot (if inserted in it), turn the head to the front, drop the right hand by the side; hook up the scabbard with the left hand, drop the left hand by the side.

Officers and noncommissioned officers armed with the saber, when mounted, return saber without using the left hand; the scabbard is hooked up on dismounting. (790)

680. Enlisted men with saber drawn at inspection. At inspection enlisted men with the saber drawn execute the first motion of **present saber** and turn the wrist to show both sides of the blade, resuming the carry when the inspector has passed. (791)

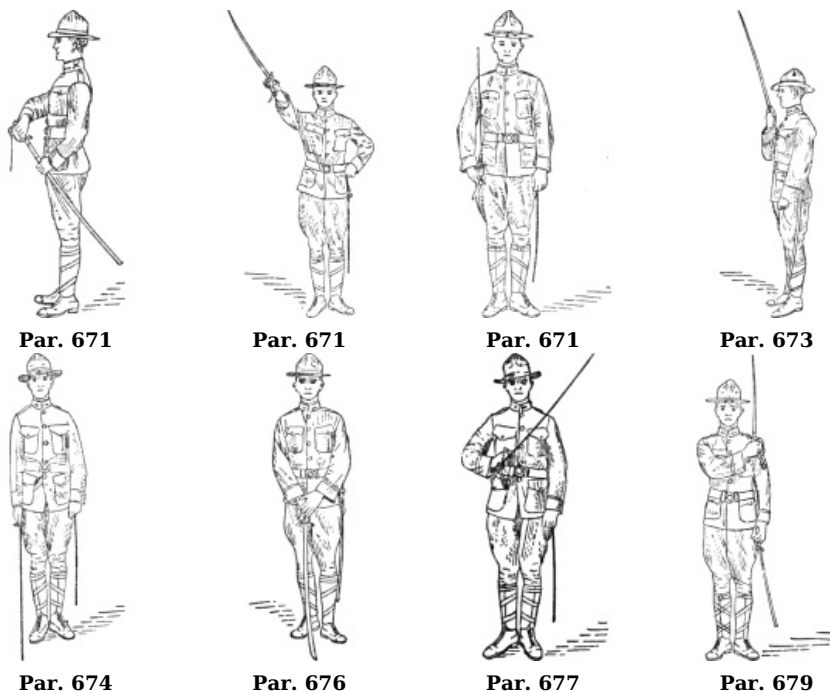

[Pg 159]

Shelter Tents

681. Being in line or in column of platoons, the captain commands: **FORM FOR SHELTER TENTS.**

The officers, first sergeant, and guides fall out; the cooks form a file on the flank of the company nearest the kitchen, the first sergeant and right guide fall in, forming the right file of the company; blank files are filled by the file closers, or by men taken from the front rank; the remaining guide, or guides, and file closers form on a convenient flank.

Before forming column or platoons, preparatory to pitching tents, the company may be redivided into two or more platoons, regardless of the size of each. (792)

682. The captain then causes the company to take intervals as described in the School of the Squad (See [par. 156.](#)), and commands: **PITCH TENTS.**

At the command **pitch tents**, each man steps off obliquely to the right with the right foot and

[Pg 160]

lays his rifle on the ground, the butt of the rifle near the toe of the right foot, muzzle to the front, barrel to the left, and steps back into his place; each front-rank man then draws his bayonet and sticks it in the ground by the outside of the right heel.

Equipments are unslung, packs opened, shelter half and pins removed; each man then spreads his shelter half, small triangle to the rear, flat upon the ground the tent is to occupy, the rear-rank man's half on the right. The halves are then buttoned together; the guy loops at both ends of the lower half are passed through the buttonholes provided in the lower and upper halves; the whipped end of the guy rope is then passed through both guy loops and secured, this at both ends of the tent. Each front-rank man inserts the muzzle of his rifle under the front end of the ridge and holds the rifle upright, sling to the front, heel of butt on the ground, beside the bayonet. His rear-rank man pins down the front corners of the tent on the line of bayonets, stretching the tent taut; he then inserts a pin in the eye of the front guy rope and drives the pin at such a distance in front of the rifle as to hold the rope taut; both men go to the rear of the tent, each pins down a corner, stretching the sides and rear of the tent before securing; the rear-rank man then inserts an intrenching tool, or a bayonet in its scabbard, under the rear end of the ridge inside the tent, the front-rank man pegging down the end of the rear guy ropes; the rest of the pins are then driven by both men, the rear-rank man working on the right.

The front flaps of the tent are not fastened down, but thrown back on the tent.

As soon as the tent is pitched each man arranges his equipment and the contents of his pack in the tent and stands at attention in front of his own half on line with the front guy-rope pin.

To have a uniform slope when the tents are pitched, the guy ropes should all be of the same length.

In shelter-tent camps, in localities where suitable material is procurable, tent poles may be improvised and used in lieu of the rifle and bayonet or intrenching tool as supports for the shelter tent. (793)

683. When the pack is not carried, the company is formed for shelter tents, as prescribed in [par. 681](#), intervals are taken, arms are laid aside or on the ground, the men are dismissed and proceed to the wagon, secure their packs, return to their places, and pitch tents as heretofore described, in [par. 682](#). (794)

[Pg 161]

684. Double shelter tents may be pitched by first pitching one tent as heretofore described, then pitching a second tent against the opening of the first, using one rifle to support both tents, and passing the front guy ropes over and down the sides of the opposite tents. The front corner of one tent is not pegged down, but is thrown back to permit an opening into the tent. (795)

Single Sleeping Bag

685. Spread the poncho on the ground, buttoned end at the feet, buttoned side to the left; fold the blanket once across its short dimension and lay it on the poncho, folded side along the right side of the poncho; tie the blanket together along the left side by means of the tapes provided; fold the left half of the poncho over the blanket and button it together along the side and bottom. (For the position, number, and length of tapes with which blankets should be provided, see Par. II, G. O. 11; W. D. '12—Author.) (796)

Double Sleeping Bag

686. Spread one poncho on the ground, buttoned end at the feet, buttoned side to the left; spread the blankets on top of the poncho; tie the edges of the blankets together with the tapes provided; spread a second poncho on top of the blankets, buttoned end at the feet, buttoned side to the right; button the two ponchos together along both sides and across the end. (797)

To Strike Shelter Tents

687. The men standing in front of their tents: **STRIKE TENTS.**

Equipments and rifles are removed from the tent; the tents are lowered, packs made up, and equipments slung, and the men stand at attention in the places originally occupied after taking intervals. (798)

To Pitch All Types of Tents, Except Shelter and Conical Wall

688. To pitch all types of Army tents, except shelter and conical wall tents: Mark line of tents by driving a wall pin on the spot to be occupied by the right (or left) corner of each tent. For pyramidal tents the interval between adjacent pins should be about 30 feet, which will give a passage of two feet between tents. Spread tripod on the ground where the center of tent is to be, if tripod is used. Spread the tent on the ground to be occupied, door to the front, and place the

right (or left) front wall loop over the pin. The door (or doors, if more than one) being fastened and held together at the bottom, the left (or right) corner wall loop is carried to the left (or right) as far as it will go and a wall pin driven through it, the pin being placed in line with the right (or left) corner pins already driven. At the same time the rear corner wall loops are pulled to the rear and outward so that the rear wall of the tent is stretched to complete the rectangle. Wall pins are then driven through these loops. Each corner pin should be directly in rear of the corresponding front corner pin, making a rectangle. Unless the canvas be wet, a small amount of slack should be allowed before the corner pins are driven. According to the size of the tent one or two men, crawling under the tent if necessary, fit each pole or ridge or upright into the ring or ridge pole holes, and such accessories as hood, fly, and brace ropes are adjusted. If a tripod be used an additional man will go under the tent to adjust it. The tent steadied by the remaining men, one at each corner guy rope, will then be raised. If the tent is a ward or storage type, corner poles will now be placed at the four corners. The four corner guy ropes are then placed over the lower notches of the large pins driven in prolongation of the diagonals at such distance as to hold the walls and ends of the tent vertical and smooth when the guy ropes are drawn taut. A wall pin is then driven through each remaining wall loop and a large pin for each guy rope is driven in line with the corner guy pins already driven. The guy ropes of the tent are placed over the lower notches, while the guy ropes of the fly are placed over the upper notches, and are then drawn taut. Brace ropes when used, are then secured to stakes or pins suitably placed. (709)

[Pg 162]

Conical Wall Tent

689. Drive the door pin and center pin 8 feet 3 inches apart. Using the hood lines, with center pin as center, describe two concentric circles with radii 8 feet 3 inches and 11 feet 3 inches. In the outer circle drive two door guy pins 3 feet apart. At intervals of about 3 feet drive the other guy pins.

In other respects conical tents are erected practically as in the case of pyramidal tents, as explained in [par. 688](#). (801)

To Strike Common, Wall, Pyramidal, and Conical Wall Tents

690. STRIKE TENTS.

The men first remove all pins except those of the four corner guy ropes, or the four quadrant guy ropes in the case of the conical wall tent. The pins are neatly piled or placed in their receptacle.

One man holds each guy, and when the ground is clear the tent is lowered, folded, or rolled and tied, the poles or tripod and pole fastened together, and the remaining pins collected. (802)

To Fold Tents

691. For folding common, wall, hospital, and storage tents: Spread the tent flat on the ground, folded at the ridge so that bottoms of side walls are even, ends of tents forming triangles to the right and left; fold the triangular ends of the tent in toward the middle, making it rectangular in shape; fold the top over about 9 inches; fold the tent in two by carrying the top fold over clear to the foot; fold again in two from the top to the foot; throw all guys on tent except the second from each end; fold the ends in so as to cover about two-thirds of the second cloths; fold the left end over to meet the turned-in edge of the right end, then fold the right end over the top, completing the bundle; tie with two exposed guys.

[Pg 163]

For folding pyramidal tents: The tent is thrown toward the rear and the back wall and roof canvas pulled out smooth. This may be most easily accomplished by leaving the rear corner wall pins in the ground with the wall loops attached, one man at each rear-corner guy, and one holding the square iron in a perpendicular position and pulling the canvas to its limit away from the former front of the tent. This leaves the three remaining sides of the tent on top of the rear side, with the door side in the middle.

Now carry the right-front corner over and lay it on the left-rear corner. Pull all canvas smooth, throw guys toward square iron, and pull bottom edges even. Then take the right-front corner and return to the right, covering the right-rear corner. This folds the right side of the tent on itself, with the crease in the middle and under the front side of the tent.

Next carry the left-front corner to the right and back as described above; this, when completed, will leave the front and rear sides of the tent lying smooth and flat and the two side walls folded inward, each on itself.

Place the hood in the square iron which has been folded downward toward the bottom of tent, and continue to fold around the square iron as a core, pressing all folds down flat and smooth, and parallel with the bottom of the tent. If each fold is compactly made and the canvas kept smooth, the last fold will exactly cover the lower edge of the canvas. Lay all exposed guys along the folded canvas except the two on the center-width, which should be pulled out and away from bottom edge to their extreme length for tying. Now, beginning at one end, fold toward the center

on the first seam (that joining the first and second widths) and fold again toward the center so that the already folded canvas will come to within about three inches of the middle width. Then fold over to the opposite edge of middle width of canvas. Then begin folding from opposite end, folding the first width in half, then making a second fold to come within about 4 or 5 inches of that already folded, turn this fold entirely over that already folded. Take the exposed guys and draw them taut across each other, turn bundle over on the under guy, cross guys on top of bundle drawing tight. Turn bundle over on the crossed guys and tie lengthwise.

When properly tied and pressed together this will make a package 11 by 23 by 34 inches, requiring about 8,855 cubic inches to store or pack.

Stencil the organization designation on the lower half of the middle width of canvas in the back wall. (803)

Warning Calls

692. First call, guard mounting, full dress, overcoats, drill, stable, water, and boots and saddles precede the **assembly** by such interval as may be prescribed by the commanding officer.

Mess, church, and fatigue, classed as service calls, may also be used as warning calls.

[Pg 164]

First call is the first signal for formation for roll call and for all ceremonies except guard mounting.

Guard mounting is the first signal for guard mounting.

The field music assembles at **first call** and **guard mounting**.

In a mixed command, **boots and saddles** is the signal to mounted troops that their formation is to be mounted; for mounted guard mounting or mounted drill, it immediately follows the signal **guard mounting** or drill.

When full dress or overcoats are to be worn, the **full dress** or **overcoat** call immediately follows **first call, guard mounting, or boots and saddles**. (804)

Formation Calls

693. Assembly: The signal for companies or details to fall in.

Adjutant's call: The signal for companies to form battalion; also for the guard details to form for guard mounting on the camp or garrison parade ground; it follows the **assembly** at such interval as may be prescribed by the commanding officer.

It is also used as a signal for the battalions to form regiment, following the first **adjutant's call** at such interval as the commanding officer may prescribe.

To the color: Is sounded when the color salutes. (805)

Alarm Calls

694. Fire call: The signal for the men to fall in, without arms, to extinguish fire.

To arms: The signal for the men to fall in, under arms, on their company's parade grounds as quickly as possible.

To horse: The signal for mounted men to proceed under arms to their horses, saddle, mount and assemble at a designated place as quickly as possible. In extended order this signal is used to remount troops. (806)

Service Calls

695. Tattoo, taps, mess, sick, church, recall, issue, officers', captains', first sergeants', fatigue, school, and the general.

The general is the signal for striking tents and loading wagons preparatory to marching.

Reveille precedes the **assembly** for roll call; **retreat** follows the **assembly**, the interval between being only that required for formation and roll call, except when there is parade.

Taps is the signal for extinguishing lights; it is usually preceded by **call to quarters** by such interval as prescribed by Army Regulations.

Assembly, reveille, retreat, adjutant's call, to the color, the flourishes, ruffles, and the

marches are sounded by all the field music united; the other calls, as a rule, are sounded by the musician of the guard or orderly musician; he may also sound the **assembly** when the musicians are not united.

The morning gun is fired at the first note of **reveille**, or, if marches be played before **reveille**, it is fired at the commencement of the first march.

[Pg 165]

The evening gun is fired at the last note of **retreat**. (807)

APPENDIX A

War Department,
Office of the Chief of Staff,
Washington, December 2, 1911.

The Infantry Drill Regulations, 1911, have been prepared for the use of troops armed with the United States magazine rifle, model 1903. For the guidance of organizations armed with the United States magazine rifle, model 1898, the following alternative paragraphs are published and will be considered as substitute paragraphs for the corresponding paragraphs in the text: [75](#) (in part), [96](#), [98](#), [99](#), [134](#), [139](#), [141](#), [142](#), [148](#) and [150](#).

By order of the Secretary of War:

LEONARD WOOD,
Major General, Chief of Staff.

Note. The paragraph numbers 75, 96, 98, etc., given above, follow the paragraphs below.

696. * * * Third.

The cut-off is kept turned down, except when using the magazine. (75)

* * * * *

697. Being at order arms: **1. Unfix, BAYONET.**

If the bayonet scabbard is carried on the belt: Take the position of parade rest, grasp the handle on the bayonet firmly with the right hand, press the spring with the forefinger of the left hand, raise the bayonet until the handle is about 6 inches above the muzzle of the piece, drop the point to the left, back of hand toward the body, and glancing at the scabbard, return the bayonet, the blade passing between the left arm and body; regrasp the piece with the right hand and resume the order.

If the bayonet scabbard is carried on the haversack: Take the bayonet from the rifle with the left hand and return it to the scabbard in the most convenient manner.

If marching or lying down, the bayonet is fixed and unfix in the most expeditious and convenient manner and the piece returned to the original position.

Fix and unfix bayonet are executed with promptness and regularity, but not in cadence. (96)

698. Being at order arms: **1. Inspection, 2. ARMS.**

At the second command, take the position of port arms. (**TWO.**) With the right hand open the magazine gate, turn the bolt handle up, draw the bolt back and glance at the magazine and chamber. Having found them empty, or having emptied them, raise the head and eyes to the front. (98)

699. Being at inspection arms: **1. Order (Right shoulder, port), 2. ARMS.**

[Pg 166]

At the preparatory command, push the bolt forward, turn the handle down, close the magazine gate, pull the trigger, and resume port arms. At the command **arms**, complete the movement ordered. (99)

700. Pieces being loaded and in the position of load, to execute other movements with the pieces loaded: **1. Lock, 2. PIECES.**

At the command **pieces** turn the safety lock fully to the right.

The safety lock is said to be at the "ready" when turned to the left, and at the "safe" when turned to the right.

The cut-off is said to be "on" when turned up and "off" when turned down. (134)

701. Being in line or skirmish line at halt: **1. With dummy (blank or ball) cartridges, 2. LOAD.**

At the command **load** each front-rank man or skirmisher faces half right and carries the right foot to the right, about one foot, to such position as will insure the greatest firmness and steadiness of the body; raises or lowers the piece and drops it into the left hand at the balance, left thumb extended along the stock, muzzle at the height of the breast. With the right hand he turns and draws the bolt back, takes a cartridge between the thumb and first two fingers and places it in the receiver; places palm of the hand against the back of the bolt handle; thrusts the bolt home with a quick motion, turning down the handle, and carries the hand to the small of the stock. Each rear-rank man moves to the right front, takes a similar position opposite the interval to the right of his front-rank man, muzzle of the piece extending beyond the front rank, and loads.

A skirmish line may load while moving, the pieces being held as nearly as practicable in the position of load.

If kneeling or sitting, the position of the piece is similar; if kneeling, the left forearm rests on the left thigh; if sitting, the elbows are supported by the knees. If lying down, the left hand steadies and supports the piece at the balance, the toe of the butt resting on the ground, the muzzle off the ground.

For reference, these positions (standing, kneeling, and lying down) are designated as that of **load**. (139)

702. FILL MAGAZINE.

Take the position of load, if not already there, open the gate of the magazine with the right thumb, take five cartridges from the box or belt, and place them, with the bullets to the front, in the magazine, turning the barrel slightly to the left to facilitate the insertion of the cartridges; close the gate and carry the right hand to the small of the stock.

To load from the magazine the command **from magazine** will be given preceding that of **load**; the **cut-off** will be turned up on coming to the position of **load**.

To resume loading from the belt the command from belt will be given preceding the command **load**; the **cut-off** will be turned down on coming to the position of **load**.

The commands **from magazine** and **from belt**, indicating the change in the manner of loading, will not be repeated in subsequent commands.

[Pg 167]

The words **from belt** apply to cartridge box as well as belt.

In loading from the magazine care should be taken to push the bolt fully forward and turn the handle down before drawing the bolt back, as otherwise the extractor will not catch the cartridge in the chamber, and jamming will occur with the cartridge following.

To fire from the magazine, the command **magazine fire** may be given at any time. The cut-off is turned up and an increased rate of fire is executed. After the magazine is exhausted the cut-off is turned down and the firing continued, loading from the belt.

Magazine fire is employed only when, in the opinion of the platoon leader or company commander, the maximum rate of fire becomes necessary. (141)

703. UNLOAD.

All take the position of load, turn the **cut-off** up, if not already there, turn the safety lock to the left, and alternately open and close the chamber until all the cartridges are ejected. After the last cartridge is ejected the chamber is closed and the trigger pulled. The cartridges are then picked up, cleaned, and returned to the box or belt, and the piece brought to the order. (142)

704. CLIP FIRE.

Turn the cut-off up; **fire at will** (reloading from the magazine) until the cartridges in the piece are exhausted; turn the cut-off down; fill magazine; reload and take the position of **suspend firing**. (148)

705. CEASE FIRING.

Firing stops; pieces not already there are brought to the position of load, the cut-off turned down if firing from magazine, the cartridge is drawn or the empty shell is ejected, the trigger is pulled, sights are laid down, and the piece is brought to the order.

Cease firing is used for long pauses to prepare for changes of position or to steady the men. (150)

APPENDIX B

[Paragraphs 747, 792, 793, 794, 795, 796, 797](#), and [798](#), Infantry Drill Regulations, 1911, apply only to troops equipped with the Infantry Equipment, model 1910. For troops equipped under General Orders, No. 23, War Department, 1906, and orders amendatory thereof, the alternative paragraphs published herewith will govern.

By order of the Secretary of War:

LEONARD WOOD,
Major General, Chief of Staff.

Note. The paragraph numbers 747, 792, etc., given above, follow the paragraphs below.

706. If the inspection is to include an examination of the blanket rolls, the captain, before dismissing the company and after inspecting the file closers, directs the lieutenants to remain in place, closes ranks, stacks arms, dresses the company back to four paces from the stacks, takes intervals, and commands: **1. Unslung, 2. PACKS, 3. Open, 4. PACKS.**

[Pg 168]

At the second command, each man unslings his roll and places it on the ground at his feet, rounded end to the front, square end of shelter half to the right.

At the fourth command, the rolls are untied, laid perpendicular to the front with the triangular end of the shelter half to the front, opened, and unrolled to the left; each man prepares the contents of his roll for inspection and resumes the attention.

The captain then returns saber, passes along the ranks and file closers as before, inspects the rolls, returns to the right, draws saber and commands: **1. Close, 2. PACKS.**

At the second command each man, with his shelter half smoothly spread on the ground with buttons up and triangular end to the front, folds his blanket once across its length and places it upon the shelter half, fold toward the bottom edge one-half inch from the square end, the same amount of canvas uncovered at the top and bottom. He then places the parts of the pole on the side of the blanket next the square end of shelter half, near and parallel to the fold, end of pole about 6 inches from the edge of the blanket; nests the pins similarly near the opposite edge of the blanket and distributes the other articles carried in the roll; folds the triangular end and then the exposed portion of the bottom of the shelter half over the blanket.

The two men in each file roll and fasten first the roll of the front and then of the rear rank man. The file closers work similarly two and two, or with the front rank man of a blank file. Each pair stands on the folded side, rolls the blanket roll closely and buckles the straps, passing the end of the strap through both keeper and buckle, back over the buckle and under the keeper. With the roll so lying on the ground that the edge of the shelter half can just be seen when looking vertically downward, one end is bent upward and over to meet the other, a clove hitch is taken with the guy rope first around the end to which it is attached and then around the other end, adjusting the length of rope between hitches to suit the wearer.

As soon as a file completes its two rolls each man places his roll in the position it was in after being unslung and stands at attention.

All the rolls being completed, the captain commands: **1. Sling, 2. PACKS.**

At the second command the rolls are slung, the end containing the pole to the rear.

The company is assembled, takes arms, and the captain completes the inspection as before. (747)

707. Being in line or in column of platoons, the captain commands: **FORM FOR SHELTER TENTS.**

The officers, first sergeant, and guides fall out; the cooks form a file on the flank of the company nearest the kitchen, the first sergeant and right guide fall in, forming the right file of the company; blank files are filled by the file closers or by men taken from the front rank; the remaining guide or guides, and file closers form on a convenient flank.

[Pg 169]

Before forming column of platoons, preparatory to pitching tents, the company may be redivided into two or more platoons, regardless of the size of each. (792)

708. The captain then causes the company to take intervals as described in the School of the Squad, and commands: **PITCH TENTS.**

At the command **pitch tents**, each man steps off obliquely to the right with the right foot and lays his rifle on the ground, the butt of the rifle near the toe of the right foot, muzzle to the front, barrel to the left, and steps back into his place; each front-rank man then draws his bayonet and sticks it in the ground by the outside of the right heel. All unslung and open the blanket rolls and take out the shelter half, poles, and pins. Each then spreads his shelter half, triangle to the rear, flat upon the ground the tent is to occupy, rear-rank man's half on the right. The halves are then buttoned together. Each front-rank man joins his pole, inserts the top in the eyes of the halves,

and holds the pole upright beside the bayonet placed in the ground; his rear-rank man, using the pins in front, pins down the front corners of the tent on the line of bayonets, stretching the canvas taut; he then inserts a pin in the eye of the rope and drives the pin at such distance in front of the pole as to hold the rope taut. Both then go to the rear of the tent; the rear-rank man adjusts the pole and the front-rank man drives the pins. The rest of the pins are then driven by both men, the rear-rank man working on the right.

As soon as the tent is pitched each man arranges the contents of the blanket roll in the tent and stands at attention in front of his own half on line with the front guy rope pin.

The guy ropes, to have a uniform slope when the shelter tents are pitched, should all be of the same length. (793)

709. When the blanket roll is not carried, intervals are taken as described above; the position of the front pole is marked with a bayonet and equipments are laid aside. The men then proceed to the wagon, secure their rolls, return to their places, and pitch tents as heretofore described. (794)

710. To pitch double shelter tent, the captain gives the same commands as before, except **Take half interval** is given instead of **Take interval**. In taking interval, each man follows the preceding man at 2 paces. The captain then commands: **PITCH DOUBLE TENTS**.

The first sergeant places himself on the right of the right guide and with him pitches a single shelter tent.

Only the odd numbers of the front rank mark the line with the bayonet.

The tent is formed by buttoning together the square ends of two single tents. Two complete tents, except one pole, are used. Two guy ropes are used at each end, the guy pins being placed in front of the corner pins.

The tents are pitched by numbers 1 and 2, front and rear rank; and by numbers 3 and 4, front and rear rank; the men falling in on the left are numbered, counting off if necessary.

All the men spread their shelter halves on the ground the tent is to occupy. Those of the front rank are placed with the triangular ends to the front. All four halves are then buttoned together, first the ridges and then the square ends. The front corners of the tent are pinned by the front-rank men, the odd number holding the poles, the even number driving the pins. The rear-rank men similarly pin the rear corners. [Pg 170]

While the odd numbers steady the poles, each even number of the front rank takes his pole and enters the tent, where, assisted by the even number of the rear rank, he adjusts the pole to the center eyes of the shelter halves in the following order: (1) The lower half of the front tent; (2) the lower half of the rear tent; (3) the upper half of the front tent; (4) the upper half of the rear tent. The guy ropes are then adjusted.

The tents having been pitched, the triangular ends are turned back, contents of the rolls arranged, and the men stand at **attention**, each opposite his own shelter half and facing out from the tent. (795)

FOOTNOTES:

- [1] No. 1 of the first squad.
- [2] Ordinarily about 20 yards wide.
- [3] By Fire Direction is meant prescribing and generally directing the firing.—Author.
- [4] The "pack" includes blanket, poncho, and shelter tent.
- [5] With a 4-foot white and red regimental signal flag.

CHAPTER II

MANUAL OF THE BAYONET

(The numbers following the paragraphs are those of the Manual of the Bayonet, U. S. Army.)

711. The infantry soldier relies mainly on fire action to disable the enemy, but he should know that personal combat is often necessary to obtain success. Therefore, he must be instructed in the use of the rifle and bayonet in hand-to-hand encounters. (1)

712. The object of this instruction is to teach the soldier how to make effective use of the rifle and bayonet in personal combat; to make him quick and proficient in handling his rifle; to give him an accurate eye and a steady hand; and to give him confidence in the bayonet in offense and defense. When skill in these exercises has been acquired, the rifle will still remain a most formidable weapon at close quarters should the bayonet be lost or disabled. (2)

713. Efficiency of organizations in bayonet fighting will be judged by the skill shown by individuals in personal combat. For this purpose pairs or groups of opponents, selected at random from among recruits and trained soldiers, should engage in assaults, using the fencing equipment provided for the purpose. (3)

714. Officers and specially selected and thoroughly instructed noncommissioned officers will act as instructors. (4)

715. Instruction in bayonet combat should begin as soon as the soldier is familiar with the handling of his rifle and will progress, as far as practicable, in the order followed in the text. (5)

716. Instruction is ordinarily given on even ground, but practice should also be had on uneven ground, especially in the attack and defense of intrenchments. (6)

717. These exercises will not be used as a calisthenic drill. (7)

718. The principles of the commands are the same as those given in [paragraphs 58, 64, and 87](#). Intervals and distances will be taken as in [paragraphs 156 and 158](#), except that, in formations for bayonet exercises, the men should be at least four paces apart in every direction. (8)

719. Before requiring soldiers to take a position or execute a movement for the first time, the instructor executes the same for the purpose of illustration, after which he requires the soldiers to execute the movement individually. Movements prescribed in this manual will not be executed in cadence as the attempt to do so results in incomplete execution and lack of vigor. Each movement will be executed correctly as quickly as possible by every man. As soon as the movements are executed accurately, the commands are given rapidly, as expertness with the bayonet depends chiefly upon quickness of motion. (9)

720. The exercises will be interrupted at first by short and frequent rests. The rests will be less frequent as proficiency is attained. Fatigue and exhaustion will be specially guarded against as they prevent proper interest being taken in the exercises and delay the progress of the instruction. Rests will be given from the position of order arms in the manner prescribed in Infantry Drill Regulations. (10)

[Pg 172]

THE BAYONET

NOMENCLATURE AND DESCRIPTION

721. The bayonet is a cutting and thrusting weapon consisting of three principal parts, viz, the blade, guard, and grip. (11)

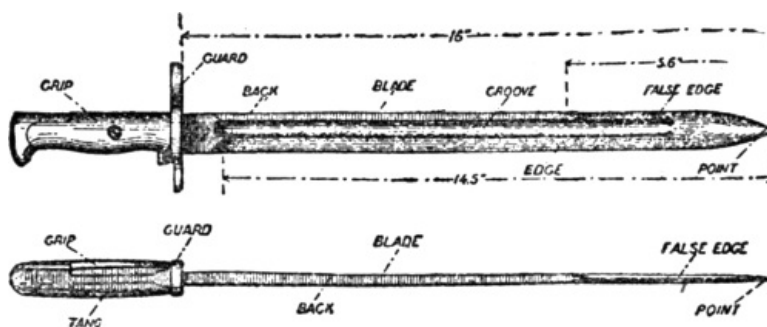

Fig. 1

722. The blade has the following parts: Edge, false edge, back, grooves, point, and tang. The length of the blade from guard to point is 16 inches, the edge 14.5 inches, and the false edge 5.6 inches. Length of the rifle, bayonet fixed, is 59.4 inches. The weight of the bayonet is 1 pound; weight of rifle without bayonet is 8.69 pounds. The center of gravity of the rifle, with bayonet fixed, is just in front of the rear sight. (12)

I. INSTRUCTION WITHOUT THE RIFLE

723. The instructor explains the importance of good footwork and impresses on the men the fact that quickness of foot and suppleness of body are as important for attack and defense as is the ability to parry and deliver a strong point or cut. (13)

724. All foot movements should be made from the position of *guard*. As far as practicable, they will be made on the balls of the feet to insure quickness and agility. No hard and fast rule can be

laid down as to the length of the various foot movements; this depends entirely on the situations occurring in combat. (14)

725. The men having taken intervals or distances, the instructor commands:

1. Bayonet exercise, 2. GUARD.

At the command **guard**, half face to the right, carry back and place the right foot about once and a half its length to the rear and about 3 inches to the right, the feet forming with each other an angle of about 60°, weight of the body balanced equally on the balls of the feet, knees slightly bent, palms of hands on hips, fingers to the front, thumbs to the rear, head erect, head and eyes straight to the front. (15)

726. To resume the attention, **1. Squad, 2. ATTENTION.** The men take the position of the soldier and fix their attention. (16)

[Pg 173]

727. **ADVANCE.** Advance the left foot quickly about once its length follow immediately with the right foot the same distance. (17)

728. **RETIRE.** Move the right foot quickly to the rear about once its length, follow immediately with the left foot the same distance. (18)

729. **1. Front, 2. PASS.** Place the right foot quickly about once its length in front of the left, advance the left foot to its proper position in front of the right. (19)

730. **1. Rear, 2. PASS.** Place the left foot quickly about once its length in rear of the right, retire the right foot to its proper position in rear of the left.

The passes are used to get quickly within striking distance or to withdraw quickly therefrom. (20)

731. **1. Right, 2. STEP.** Step to the right with the right foot about once its length and place the left foot in its proper relative position. (21)

732. **1. Left, 2. STEP.** Step to the left with the left foot about once its length and place the right foot in its proper relative position.

These steps are used to circle around an enemy, to secure a more favorable line of attack, or to avoid the opponent's attack. Better ground or more favorable light may be gained in this way. In bayonet fencing and in actual combat the foot first moved in stepping to the right or left is the one which at the moment bears the least weight. (22)

II. INSTRUCTION WITH THE RIFLE

733. The commands for and the execution of the foot movements are the same as already given for movements without the rifle. (23)

734. The men having taken intervals or distances, the instructor commands:

1. Bayonet exercise, 2. GUARD.

At the second command take the position of guard (see [par. 15](#)); at the same time throw the rifle smartly to the front, grasp the rifle with the left hand just below the lower band, fingers between the stock and gun sling, barrel turned slightly to the left, the right hand grasping the small of the stock about 6 inches in front of the right hip, elbows free from the body, bayonet point at the height of the chin. (24) (See [Fig. 2](#))

735. 1. Order, 2. ARMS.

Bring the right foot up to the left and the rifle to the position of order arms, at the same time resuming the position of attention. (25)

736. During the preliminary instruction, attacks and defenses will be executed from guard until proficiency is attained, after which they may be executed from any position in which the rifle is held. (26)

ATTACKS

737. 1. THRUST.

Thrust the rifle quickly forward to the full length of the left arm, turning the barrel to the left, and direct the point of the bayonet at the point to be attacked, butt covering the right forearm. At the same time straighten the right leg vigorously and throw the weight of the body forward and on the left leg, the ball of the right foot always on the ground. Guard is resumed immediately without command.

[Pg 174]



Fig. 2



Fig. 3

The force of the thrust is delivered principally with the right arm, the left being used to direct the bayonet. The points at which the attack should be directed are, in order of their importance, stomach, chest, head, neck, and limbs. (27)

738. 1. LUNGE.

Executed in the same manner as the thrust, except that the left foot is carried forward about twice its length. The left heel must always be in rear of the left knee. Guard is resumed immediately without command. Guard may also be resumed by advancing the right foot if, for any reason, it is desired to hold the ground gained in lunging. In the latter case, the preparatory command **forward** will be given. Each method should be practiced. (28)

739. 1. Butt, 2. STRIKE.

[Pg 175]

Straighten right arm and right leg vigorously and swing butt of rifle against point of attack, pivoting the rifle in the left hand at about the height of the left shoulder, allowing the bayonet to pass to the rear on the left side of the head. Guard is resumed without command.

The points of attack in their order of importance are, head, neck, stomach, and crotch. (29)



Fig. 4



Fig. 5

740. 1. Cut, 2. DOWN.

[Pg 176]

Execute a quick downward stroke, edge of bayonet directed at point of attack. Guard is resumed without command. (30)

741. 1. Cut, 2. RIGHT (LEFT).

With a quick extension of the arms execute a cut to the right (left), directing the edge toward the point attacked. Guard is resumed without command.

The cuts are especially useful against the head, neck, and hands of an enemy. In executing left cut it should be remembered that the false, or back edge, is only 5.6 inches long. The cuts can be executed in continuation of strokes, thrusts, lunges, and parries. (31)

742. To direct an attack to the right, left, or rear the soldier will change front as quickly as possible in the most convenient manner, for example: **1. To the right rear, 2. Cut, 3. DOWN; 1. To the right, 2. LUNGE; 1. To the left, 2. THRUST**, etc.

Whenever possible the impetus gained by the turning movement of the body should be thrown into the attack. In general this will be best accomplished by turning on the ball of the right foot.

These movements constitute a change of front in which the position of guard is resumed at the completion of the movement. (32)

743. Good judgment of distance is essential. Accuracy in thrusting and lunging is best attained by practicing these attacks against rings or other convenient openings, about 3 inches in diameter, suitably suspended at desired heights. (33)



Fig. 6.

744. The thrust and lunges at rings should first be practiced by endeavoring to hit the opening looked at. This should be followed by directing the attack against one opening while looking at another. (34)

[Pg 177]

745. The soldier should also experience the effect of actual resistance offered to the bayonet and the butt of the rifle in attacks. This will be taught by practicing attacks against a dummy. (35)



Fig. 7.

746. Dummies should be constructed in such a manner as to permit the execution of attacks without injury to the point or edge of the bayonet or to the barrel or stock of the rifle. A suitable dummy can be made from pieces of rope about 5 feet in length plaited closely together into a cable between 6 and 12 inches in diameter. Old rope is preferable. Bags weighted and stuffed with hay, straw, shavings, etc., are also suitable. (36)

DEFENSES

747. In the preliminary drills in the defenses the position of guard is resumed, by command, after each parry. When the men have become proficient, the instructor will cause them to resume the position of guard instantly without command after the execution of each parry. (37)

748. 1. Parry, 2. RIGHT.

Keeping the right hand in the guard position, move the rifle sharply to the right with the left arm, so that the bayonet point is about 6 inches to the right. (38)

749. 1. Parry, 2. LEFT.

Move the rifle sharply to the left front with both hands so as to cover the point attacked. (39)

750. 1. Parry, 2. HIGH.

Raise the rifle with both hands high enough to clear the line of vision, barrel downward, point of the bayonet to the left front.

When necessary to raise the rifle well above the head, it may be supported between the thumb and forefinger of the left hand. This position will be necessary against attacks from higher elevations, such, as men mounted or on top of parapets. (40)



Fig. 8



Fig. 9

[Pg 178]

751. 1. Low parry, 2. RIGHT (LEFT).

Carry the point of the bayonet down until it is at the height of the knee, moving the point of the bayonet sufficiently to the right (left) to keep the opponent's attacks clear of the point threatened.

752. These parries are rarely used, as an attack below the waist leaves the head and body exposed. (41)



Fig. 10

Fig. 11

[Pg 179]

753. Parries must not be too wide or sweeping, but sharp, short motions, finished with a jerk or quick catch. The hands should, as far as possible, be kept in the line of attack. Parries against **butt strike** are made by quickly moving the guard so as to cover the point attacked. (42)

754. To provide against attack from the right, left, or rear the soldier will change front as quickly as possible in the most convenient manner, for example, **1. To the left rear, 2. Parry, 3. HIGH; 1. To the right, 2. Parry, 3. RIGHT**, etc.

These movements constitute a change of front in which the position of guard is resumed at the completion of the movement.

In changing front for the purpose of attack or defense, if there is danger of wounding a comrade, the rifle should first be brought to a vertical position. (43)

III. INSTRUCTION WITHOUT THE BAYONET

755. 1. Club rifle, 2 SWING.

Being at order arms at the preparatory command quickly raise and turn the rifle, regripping it with both hands between the rear sight and muzzle, barrel down, thumbs around the stock and toward the butt; at the same time raise the rifle above shoulder farthest from the opponent, butt elevated and to the rear, elbows slightly bent and knees straight. Each individual takes such position of the feet, shoulders, and hands as best accords with his natural dexterity. **SWING.** Tighten the grasp of the hands and swing the rifle to the front and downward, directing it at the head of the opponent and immediately return to the position of **club rifle** by completing the swing of the rifle downward and to the rear. Repeat by the command. **SWING.**

[Pg 180]

The rifle should be swung with sufficient force to break through any guard or parry that may be interposed.

Being at **club rifle**, order arms is resumed by command.

The use of this attack against dummies or in fencing is prohibited. (44)



Fig. 12

756. The position of club rifle may be taken from any position of the rifle prescribed in the Manual of Arms. It will not be taken in personal combat unless the emergency is such as to preclude the use of the bayonet. (45)

[Pg 181]

IV. COMBINED MOVEMENTS

757. The purpose of combined movements is to develop more vigorous attacks and more effective defenses than are obtained by the single movements; to develop skill in passing from attack to defense and the reverse. Every movement to the front should be accompanied by an attack, which is increased in effectiveness by the forward movement of the body. Every movement to the rear should ordinarily be accompanied by a parry and should always be followed by an attack. Movements to the right or left may be accompanied by **attacks** or **defenses**. (46)

758. Not more than three movements will be used in any combination. The instructor should first indicate the number of movements that are to be combined as **two movements** or **three movements**. The execution is determined by one command of execution, and the position of guard is taken upon the completion of the last movement only.

EXAMPLES

Front pass and LUNGE.

Right step and THRUST.

Left step and low parry RIGHT.

Rear pass, parry left and LUNGE.

Lunge and cut RIGHT.

Parry right and parry HIGH.

Butt strike and cut DOWN.

Thrust and parry HIGH.

Parry high and LUNGE.

Advance, thrust and cut RIGHT.

Right step, parry left and cut DOWN.

To the left, butt strike and cut DOWN.

To the right rear, cut down and butt STRIKE. (47)

759. Attacks against dummies will be practiced. The approach will be made against the dummies both in quick time and double time. (48)

V. PRACTICAL BAYONET COMBAT

760. The principles of practical bayonet combat should be taught as far as possible during the progress of instruction in bayonet exercises. (49)

761. The soldier must be continually impressed with the extreme importance of the offensive due to its moral effect. Should an attack fail, it should be followed immediately by another attack before the opponent has an opportunity to assume the offensive. Keep the opponent on the defensive. If, due to circumstances, it is necessary to take the defensive, constantly watch for an opportunity to assume the offensive and take immediate advantage of it. (50)

762. Observe the ground with a view to obtaining the best footing. Time for this will generally be too limited to permit more than a single hasty glance. (51)

763. In personal combat watch the opponent's eyes if they can be plainly seen, and do not fix the eyes on his weapon nor upon the point of your attack. If his eyes can not be plainly seen, as in night attacks, watch the movements of his weapon and of his body. (52)

[Pg 182]

764. Keep the body well covered and deliver attacks vigorously. The point of the bayonet should always be kept as nearly as possible in the line of attack. The less the rifle is moved upward, downward, to the right, or to the left, the better prepared the soldier is for attack or defense. (53)

765. Constantly watch for a chance to attack the opponent's left hand. His position of guard will not differ materially from that described in [paragraph 24](#). If his bayonet is without a cutting edge, he will be at a great disadvantage. (34)

766. The butt is used for close and sudden attacks. It is particularly useful in riot duty. From the position of port arms a sentry can strike a severe blow with the butt of the rifle. (55)

767. Against a man on foot, armed with a sword, be careful that the muzzle of the rifle is not grasped. All the swordsman's energies will be directed toward getting past the bayonet. Attack him with short stabbing thrusts, and keep him beyond striking distance of his weapon. (56)

768. The adversary may attempt a greater extension in the thrust and lunge by quitting the grasp of his piece with the left hand and advancing the right as far as possible. When this is done, a sharp parry may cause him to lose control of his rifle, leaving him exposed to a counter-attack, which should follow promptly. (57)

769. Against odds a small number of men can fight to best advantage by grouping themselves so as to prevent their being attacked from behind. (58)

770. In fighting a mounted man armed with a saber every effort must be made to get on his near or left side, because here his reach is much shorter and his parries much weaker. If not possible to disable such an enemy, attack his horse and then renew the attack on the horseman. (59)

771. In receiving night attacks the assailant's movements can be best observed from the kneeling or prone position, as his approach generally brings him against the sky line. When he arrives within attacking distance rise quickly and lunge well forward at the middle of his body. (60)

VI. FENCING EXERCISES

772. Fencing exercises in two lines consist of combinations of thrusts, parries, and foot movements executed at command or at will, the opponent replying with suitable parries and returns. (61)

773. The instructor will inspect the entire fencing equipment before the exercise begins and assure himself that everything is in such condition as will prevent accidents. (62)

774. The men equip themselves and form in two lines at the order, facing each other, with intervals of about 4 paces between files and a distance of about 2 paces between lines. One line is designated as number 1; the other, number 2. Also as attack and defense. (63)

775. The opponents being at the order facing each other, the instructor commands: **SALUTE.**

Each man, with eyes on his opponent, carries the left hand smartly to the right side, palm of the hand down, thumb and fingers extended and joined, forearm horizontal, forefinger touching the bayonet. (Two) Drop the arm smartly by the side.

[Pg 183]

This salute is the fencing salute.

All fencing exercises and all fencing at will between individuals will begin and terminate with the formal courtesy of the fencing salute. (64)

776. After the fencing salute has been rendered the instructor commands: **1. Fencing exercise, 2. GUARD.**

At the command **guard** each man comes to the position of **guard**, heretofore defined, bayonets crossed, each man's bayonet bearing lightly to the right against the corresponding portion of the opponent's bayonet. The position is known as the engage or engage right. (65)

777. Being at the **engage right: ENGAGE LEFT.**

The attack drops the point of his bayonet quickly until clear of his opponent's rifle and describes a semicircle with it upward and to the right; bayonets are crossed similarly as in the engaged position, each man's bayonet bearing lightly to the left against the corresponding portion of the opponent's bayonet. (66)

778. Being at **engage left: ENGAGE RIGHT.**

The attack quickly drops the point of his bayonet until clear of his opponent's rifle and describes a semicircle with it upward and to the left and **engages**. (67)

779. Being **engaged: ENGAGE LEFT AND RIGHT.**

The attack **engages left** and then immediately **engages right**. (68)

780. Being **engaged left: ENGAGE RIGHT AND LEFT.**

The attack **engages right** and then immediately **engages left**. (69)

781. 1. Number one, ENGAGE RIGHT (LEFT); 2. Number two, COUNTER.

Number one executes the movement ordered, as above; number two quickly drops the point of his bayonet and circles it upward to the original position. (70)

782. In all fencing while maintaining the pressure in the engage, a certain freedom of motion of the rifle is allowable, consisting of the play, or up-and-down motion, of one bayonet against the other. This is necessary to prevent the opponent from divining the intended attack. It also prevents his using the point of contact as a pivot for his assaults. In changing from one engage to the other the movement is controlled by the left hand, the right remaining stationary. (71)

783. After some exercise in **engage, engage left, and counter**, exercises will be given in the **assaults**. (72)

784. The part of the body to be attacked will be designated by name as head, neck, chest, stomach, legs. No attacks will be made below the knees. The commands are given and the movements for each line are first explained thoroughly by the instructor; the execution begins at the command **assault**. Number one executes the attack, and number two parries; conversely, at command, number two attacks and number one parries. (73)

785. For convenience in instruction assaults are divided into **simple attacks, counter-attacks, attack on the rifle, and feints**. (74)

SIMPLE ATTACKS

786. Success in these attacks depends on quickness of movement. There are three simple attacks—the **straight**, the **disengagement**, and the **counter disengagement**. They are not preceded by a feint. (75)

787. In the **straight** the bayonet is directed straight at an opening from the engaged position. Contact with the opponent's rifle may, or may not, be abandoned while making it. If the opening be high or low, contact with the rifle will usually be abandoned on commencing the attack. If the opening be near his guard, the light pressure used in the engage may be continued in the attack.

Example: Being at the **engage right, 1. Number one**, at neck (head, chest, right leg, etc.), **thrust; 2. Number two, parry right; 3. ASSAULT**. (76)

788. In the **disengagement** contact with the opponent's rifle is abandoned and the point of the bayonet is **circled under** or **over** his bayonet or rifle and directed into the opening attacked. This attack is delivered by one continuous spiral movement of the bayonet from the moment contact is abandoned.

Example: Being at the **engage right, 1. Number one**, at stomach (left chest, left leg, etc.), **thrust, 2. Number two, parry left** (etc.); **3. ASSAULT**. (77)

789. In the **counter disengagement** a swift attack is made into the opening disclosed while the opponent is attempting to change the engagement of his rifle. It is delivered by one continuous spiral movement of the bayonet into the opening.

Example: Being at the **engage right, 1. Number two, engage left; 2. Number one**, at chest, **thrust; 3. Number two, parry left; 4. ASSAULT**.

Number two initiates the movement, number one thrusts as soon as the opening is made, and number two then attempts to parry. (78)

790. A **counter-attack** or **return** is one made instantly after or in continuation of a parry. The parry should be as narrow as possible. This makes it more difficult for the opponent to recover and counter parry. The counter-attack should also be made at, or just before, the full extension of the opponent's attack, as when it is so made, a simple extension of the arms will generally be sufficient to reach the opponent's body.

Example: Being at **engage, 1. Number two**, at chest, **lunge; 2. Number one, parry right**, and at stomach (chest, head, etc.), **thrust; 3. ASSAULT**. (79)

ATTACKS ON THE RIFLE

791. These movements are made for the purpose of forcing or disclosing an opening into which an attack can be made. They are the **press**, the **beat**, and the **twist**. (80)

792. In the **press** the attack quickly presses against the opponent's bayonet or rifle with his own and continues the pressure as the attack is delivered.

[Pg 185]

Example: Being at the **engage, 1. Number one, press**, and at chest, **thrust; 2. Number two, parry right; 3. ASSAULT**. (81)

793. The attack by **disengagement** is particularly effective following **the press**.

Example: Being at the **engage, 1. Number one, press**, and at stomach, **thrust; 2. Number two, low parry left; 3. ASSAULT**. (82)

794. The **beat** is an attack in which a sharp blow struck against the opponent's rifle for the purpose of forcing him to expose an opening into which an attack immediately follows. It is used when there is but slight opposition or no contact of rifles.

Example: Being at the **engage, 1. Number one, beat** and at stomach (chest, etc.), **thrust; 2. Number two, parry left; 3. ASSAULT**. (83)

795. In the **twist** the rifle is crossed over the opponent's rifle or bayonet and his bayonet forced downward with a circular motion and a straight attack made into the opening. It requires superior strength on the part of the attack.

Example: Being at the **engage, 1. Number one, twist**, and at stomach, **thrust; 2. Number two, low parry, left; 3. ASSAULT.** (84)

FEINTS

796. Feints are movements which threaten or simulate attacks and are made with a view to inducing an opening or parry that exposes the desired point of attack. They are either single or double, according to the number of such movements made by the attack. (85)

797. In order that the attack may be changed quickly, as little force as possible is put into a feint.

Example: Being at the **engage, 1. Number one, feint head thrust** at stomach, **lunge; 2. Number two, parry right and low parry right; 3. ASSAULT.**

Number one executes the feint and then the attack. Number two executes both parries. (86)

798. In double feints first one part of the body and then another is threatened and a third attacked.

Example: Being at the **engage, 1. Number one, feint straight thrust** at chest; **disengagement** at chest; at stomach, **lunge; 2. Number two, parry right, parry left, and low parry left; 3. ASSAULT.** (87)

799. An opening may be offered or procured by opposition, as in the **press** or **beat.** (88)

800. In fencing exercises every feint should at first be parried. When the defense is able to judge or divine the character of the attack the feint is not necessarily parried, but may be nullified by a counter feint. (89)

801. A **counter feint** is a feint following the opponent's feint or following a parry of his attack and generally occurs in combined movements. (90)

[Pg 186]

COMBINED MOVEMENTS

802. When the men have become thoroughly familiar with the various foot movements, parries, guards, attacks, feints, etc., the instructor combines several of them and gives the commands in quick succession, increasing the rapidity and number of movements as the men become more skillful. Opponents will be changed frequently.

1. Example: Being at the **engage, 1. Number one, by disengagement** at chest, **thrust; 2. Number two, parry left, right step** (left foot first), and **lunge; 3. ASSAULT.**

2. Example: Being at **engage left, 1. Number one, press and lunge; 2. Number two, parry right, left step**, and **thrust; 3. ASSAULT.**

3. Example: Being at the **engage, 1. Number one, by disengagement** at chest, **thrust; 2. Number two, parry left, front pass**, and at head **butt strike; 3. Number one, right step; 4. ASSAULT.** (91)

803. Examples 1 and 2 are typical of movements known as **cross counters**, and example No. 3 of movements known as **close counters.** (92)

804. A **chancery** is an attack by means of which the opponent is disarmed, which causes him to lose control of his rifle, or which disables his weapon. (93)

805. When the different combinations are executed with sufficient skill the instructor will devise series of movements to be memorized and executed at the command assault. The accuracy and celerity of the movements will be carefully watched by the instructor, with a view to the correction of faulty execution. (94)

806. It is not intended to restrict the number of movements, but to leave to the discretion of company commanders and the ingenuity of instructors the selection of such other exercises as accord with the object of the drill. (95)

VII. FENCING AT WILL

807. As satisfactory progress is made the instructor will proceed to the exercises at will, by

which is meant assaults between two men, each endeavoring to hit the other and to avoid being hit himself. Fencing at will should not be allowed to degenerate into random attacks and defenses. (96)

808. The instructor can supervise but one pair of combatants at a time. Frequent changes should be made so that the men may learn different methods of attack and defense from each other. (97)

809. The contest should begin with simple, careful movements, with a view to forming a correct opinion of the adversary; afterwards everything will depend on coolness, rapid and correct execution of the movements and quick perception of the adversary's intentions. (98)

810. Continual retreat from the adversary's attack and frequent dodging to escape attacks should be avoided. The offensive should be continually encouraged. (99)

811. In fencing at will, when no commands are given, opponents facing each other at the position of order arms, salute. They then immediately and simultaneously assume the position of guard, rifles engaged. Neither man may take the position of guard before his opponent has completed his salute. The choice of position is decided before the salute. (100)

[Pg 187]

812. The opponents being about two paces apart and the fencing salute having been rendered, the instructor commands, **1. At will, 2. ASSAULT**, after which either party has the right to attack. To interrupt the contest the instructor will command **HALT**, at which the combatants will immediately come to the order. To terminate the contest the instructor will command, **1. Halt, 2. SALUTE**, at which the combatants will immediately come to the order, salute, and remove their masks. (101)

813. When men have acquired confidence in fencing at will, one opponent should be required to advance upon the other in quick time at **charge bayonet**, from a distance not to exceed 10 yards, and deliver an attack. As soon as a hit is made by either opponent the instructor commands, **HALT**, and the assault terminates. Opponents alternate in assaulting. The assailant is likewise required to advance at double time from a distance not exceeding 20 yards and at a run from a distance not exceeding 30 yards. (102)

814. The instructor will closely observe the contest and decide doubtful points. He will at once stop the contest upon the slightest indication of temper. After conclusion of the combat he will comment on the action of both parties, point out errors and deficiencies and explain how they may be avoided in the future. (103)

815. As additional instruction, the men may be permitted to wield the rifle left handed, that is on the left side of the body, left hand at the small of the stock. Many men will be able to use this method to advantage. It is also of value in case the left hand is wounded. (104)

[Pg 188]



Fig. 13

816. After men have fenced in pairs, practice should be given in fencing between groups, equally and unequally divided. When practicable, intrenchments will be used in fencing of this character.

In group fencing it will be necessary to have a sufficient number of umpires to decide hits. An individual receiving a hit is withdrawn at once from the bout, which is decided in favor of the group having the numerical superiority at the end. The fencing salute is not required in group fencing. (105)

RULES FOR FENCING AT WILL

817. 1. Hits on the legs below the knees will not be counted. No hit counts unless, in the opinion of the instructor, it has sufficient force to disable.

2. Upon receiving a hit, call out "hit."

3. After receiving a fair hit a counter-attack is not permitted. A position of engage is taken.

4. A second or third hit in a combined attack will be counted only when the first hit was not called.

5. When it is necessary to stop the contest—for example, because of breaking of weapons or displacement of means of protection—take the position of the order.
6. When it is necessary to suspend the assault for any cause, it will not be resumed until the adversary is ready and in condition to defend himself.
7. Attacks directed at the crotch are prohibited in fencing.
8. Stepping out of bounds, when established, counts as a hit. (106)

SUGGESTIONS FOR FENCING AT WILL

818. When engaging in an assault, first study the adversary's position and proceed by false attacks, executed with speed, to discover, if possible, his instinctive parries. In order to draw the adversary out and induce him to expose that part of the body at which the attack is to be made, it is advisable to simulate an attack by a feint and then make the real attack. (107)

819. Return attacks should be frequently practiced, as they are difficult to parry, and the opponent is within easier reach and more exposed. The return can be made a continuation of the parry, as there is no previous warning of its delivery, although it should always be expected. Returns are made without lunging if the adversary can be reached by thrusts or cuts. (108)

820. Endeavor to overcome the tendency to make a return without knowing where it will hit. Making returns blindly is a bad habit and leads to instinctive returns—that is, habitual returns with certain attacks from certain parries—a fault which the skilled opponent will soon discover. (109)

821. Do not draw the rifle back preparatory to thrusting and lunging (110)

822. The purpose of fencing at will is to teach the soldier as many forms of simple, effective attacks and defenses as possible. Complicated and intricate movements should not be attempted. (111)

[Pg 189]

HINTS FOR INSTRUCTORS

823. The influence of the instructor is great. He must be master of his weapon, not only to show the various movements, but also to lead in the exercises at will. He should stimulate the zeal of the men and arouse pleasure in the work. Officers should qualify themselves as instructors by fencing with each other. (112)

LESSONS OF THE EUROPEAN WAR

824. Modification of our system of bayonet combat suggested. The above gives, in toto, the system of bayonet exercises and combat at present prescribed by the War Department in the **Manual of the Bayonet**. However, the use of the bayonet in the present European war, which has given that weapon an importance and prominence heretofore unheard of, suggests, as indicated below, certain modifications of our system.

(a) *Attack not to be directed against chest.* The attack should be directed at the adversary's neck or stomach, and not against his chest; for, if the bayonet is driven into the chest, there will probably be difficulty in withdrawing it, and while your bayonet is being so held, imbedded in your adversary's chest, you are at the mercy of any other enemy soldier free to strike you.

(b) *Mêlée on parapet.* When the first wave of an attacking line reaches the enemy's trench, it is usually met outside the trench, the mêlée taking place on the parapet, and fortunate is the man who is skilled in handling his bayonet. Such a man has a much greater chance to live through the mêlée than the one who is not skillful in using his bayonet. In the excitement and confusion of this mêlée the greatest possible care must be taken not to stab some of your own men in the back.

(c) *Position of feet.* The British have been teaching their men to keep both feet pointing toward the enemy instead of having the right foot turned to the right, as in our system. Note the position of the feet in [Figs. 15-18](#).

(d) *The "Short point" (or "Short thrust") and the "Jab."* There are two attacks used by European troops which we might learn with profit. They are the "Short point" (or "Short thrust") and the "Jab."

[Pg 190]

POSITION OF GUARD



Fig. 14

(e) *The short point (or short thrust).* The *short point* (or *short thrust*) is taken from the position of guard (Fig. 14), by slipping the left hand up to the grip of the bayonet, grasping it and the barrel, as shown in this figure:



Fig. 15

The rifle is then drawn back to the fullest extent of the right arm, thus:



Fig. 16

and a vigorous thrust is made at the objective (Fig. 15), immediately after which the bayonet is withdrawn vigorously, the left hand relaxed and the position of guard (Fig. 14) is resumed by pushing the rifle smartly forward until the left hand is in its proper place.

It should be practiced on sand bags or other targets in positions at the height of the rifle, above it and below it.

(f) *The jab.* The jab is taken from the first position of the "Short point" (Fig. 15), by slipping the right hand up to the left as the rifle is drawn back to make the "Short thrust" (Fig. 17). [Pg 191]



Fig. 17

Then make a vigorous *upward* thrust (Fig. 18) which should be aimed at the adversary's throat.



Fig. 18

This may be practiced combined with the short thrust or the ordinary thrust. It may also be practiced with a run toward the target. It is a useful attack at close quarters.

(g) *The butt.* The rifle butt is used with great effect at close quarters, the blows being directed against an adversary's jaw or in the region of the heart.

(h) *Tripping adversary.* The men are taught how to trip up an enemy and how to use their knees in throwing their opponents off their balance. [Pg 192]

(i) *Withdrawing the bayonet.* After driving the bayonet into an opponent, then the first consideration is to get it out of his body. This may be done by slipping the left hand up to the bayonet grip and exerting a *vigorous* pull, which is immediately followed by a return to the position of guard.

(j) *Points in training.* In the first stages of training, special attention is paid to a firm grip and proper handling of arms; then the greatest attention is given to "direction" when thrusting, lunging, and parrying.

Until these essentials have been thoroughly mastered, quickness should not be insisted upon.

Confidence comes after continued practice, and quickness and vigor will come with confidence.

After the men are taught to make all the attacks as individuals they should be given practice in them as groups.

Sandbags with discs marked on them to provide targets are used in instructing the British armies.

These bags are suspended from trees or trestles, or are put into trenches or pits, and are also placed on the ground.

An excellent scheme is used in teaching the men what the shock of a charge is like. The men are divided into two or more groups and are equipped with fencing outfits. One group is designated as the defense and is placed in trenches. The other groups are the attackers. They may be sent forward in waves or in one line. To make their advance more realistic they have to get over or around obstacles. To take in all phases the attackers are made stronger than the defense and the defense retires—whereupon the attackers endeavor to disable them by thrusting at the kidneys. Likewise the defense is made strong enough to drive off the offense.

In the charge the men are taught to run at the "High Port" (the rifle is held as in "Port arms," but is carried well above the head). The rifle is brought down to guard just before the enemy is met.

APPENDIX D

[Pg 192a]

SEPTEMBER 15, 1917

INFANTRY DRILL REGULATIONS, 1911.

[Paragraphs 120, 143, 146, 185, 187, 189, 194, 646](#), Infantry Drill Regulations, 1911, apply only to troops armed with the United States rifle, Model 1903. For troops armed with the United States rifle, Model 1917 (Enfield), the alternative paragraphs published herewith will govern.

By order of the Secretary of War:

120. The following rules govern the carrying of the piece:

First. The piece is not carried with cartridges in either the chamber or the magazine except when especially ordered. When so loaded, or supposed to be loaded, it is habitually carried locked; that is, with safety lock turned to the "**Safe.**" At all other times it is carried unlocked, with the trigger

pulled.

Second. Whenever troops are formed under arms, pieces are immediately inspected at the commands: **1. INSPECTION, 2. ARMS, 3. ORDER (Right shoulder port), 4. ARMS.**

A similar inspection is made immediately before dismissal.

If cartridges are found in the chamber or magazine they are removed and placed in the belt.

Third. The bayonet is not fixed except in bayonet exercise, on guard, or for combat.

Fourth. **Fall in** is executed with the piece at the order arms. **Fall out, rest, and at ease** are executed as without arms. On resuming attention the position of order arms is taken.

Fifth. If at the order, unless otherwise prescribed, the piece is brought to the right shoulder, at the command **MARCH**, the three motions corresponding with the first three steps. Movements may be executed at the trail by prefacing the preparatory command with the words **at trail**; as **1. AT TRAIL, FORWARD, 2. MARCH.** The trail is taken at the command **MARCH.**

When the facings, alignments, open and close ranks, taking interval or distance, and assemblings are executed from the order, raise the piece to the trail while in motion and resume the order on halting.

Sixth. The piece is brought to the order on halting. The execution of the order begins when the halt is completed.

Seventh. A disengaged hand in double time is held as when without arms.

143. Being at order arms: 1. UNFIX, 2. BAYONET.

If the bayonet scabbard is carried on the belt: Execute parade rest; grasp the handle of the bayonet firmly with the right hand, pressing the spring with the forefinger of the left hand; raise the bayonet until the handle is about 12 inches above the muzzle of the piece; the point to the left, back of the hand toward the body, and glancing at the scabbard, return the bayonet, the blade passing between the left arm and the body; regrasp the piece with the right hand and resume the order.

[Pg 192b]

If the bayonet scabbard is carried on the haversack: Take the bayonet from the rifle with the left hand and return it to the scabbard in the most convenient manner.

If marching or lying down, the bayonet is fixed and unfixed in the most expeditious and convenient manner and the piece returned to the original position.

Fix and unfix bayonet are executed with promptness and regularity, but not in cadence.

146. Being at inspection arms: 1. ORDER (Right shoulder, port), 2. ARMS.

At the preparatory command press the follower down with the fingers of the left hand, then push the bolt forward just enough to engage the follower, raise the fingers of the left hand, push the bolt forward, turn the handle down, pull the trigger, and resume **port arms.** At the command **ARMS,** complete the movement ordered.

To Load

185. Being in line or skirmish line at halt: 1. WITH DUMMY (Blank or ball) CARTRIDGES, 2. LOAD.

At the command **load** each front rank man or skirmisher faces half right and carries the right foot to the right, about 1 foot, to such a position as will insure the greatest firmness and steadiness of the body; raises or lowers the piece and drops it into the left hand at the balance, left thumb extended along the stock and muzzle at the height of the breast. With the right hand he turns and draws the bolt back, takes a loaded clip and inserts the end in the clip slots, places the thumb on the powder space at the top cartridge, the fingers extending around the piece and tips resting on the magazine floor plate; forces the cartridges into the magazine by pressing down with the thumb; without removing the clip, thrusts the bolt home, turning down the handle; turns the safety lock to the "Safe" and carries the hand to the small of the stock. Each rear rank man moves to the right front, takes a similar position opposite the interval to the right of his front rank man, muzzle of the piece extending beyond the front rank, and loads.

A skirmish line may load while moving, the pieces being held as nearly as practicable in the position of load.

If kneeling or sitting, the position of the piece is similar; if kneeling, the left forearm rests on the left thigh; if sitting, the elbows are supported by the knees. If lying down, the left hand steadies and supports the piece at the balance, the toe of the butt resting on the ground, the muzzle off the ground.

For reference, these positions (standing, kneeling, and lying down) are designated as that of **load**.

186. For purposes of simulating firing, **1. SIMULATE, 2. LOAD**, raise the bolt handle as in the preceding paragraph, draw the bolt back until the cocking piece engages, then close the bolt, and turn the bolt handle down.

The recruits are first taught to simulate loading and firing; after a few lessons dummy cartridges are used. Later, blank cartridges may be used. [Pg 192c]

Omit last paragraph.

187. Unload: Take the position of load, turn the safety lock up and move the bolt alternately backward and forward until all the cartridges are ejected. After the last cartridge is ejected the chamber is closed by pressing the follower down with the fingers of the left hand, to engage it under the bolt, and then thrusting the bolt home. The trigger is pulled. The cartridges are then picked up, cleaned, and returned to the belt and the piece is brought to the order.

189. [Last paragraph]. To continue the firing: **1. AIM, 2. SQUAD, 3. FIRE.**

Each command is executed as previously explained. **Load** is executed by drawing back and thrusting home the bolt with the right hand, leaving the safety lock at the "Ready."

194. Cease firing: Firing stops; pieces are loaded and locked; the sights are laid down and the piece is brought to the order. Cease firing is used for long pauses to prepare for changes of position or to steady the men.

Company Inspection

646. Being in line at halt: **1. OPEN RANKS, 2. MARCH.**

At the command **march** the front rank executes right dress; the rear rank and the file closers march backward 4 steps, halt, and execute right dress; the lieutenants pass around their respective flanks and take post, facing to the front, 3 paces in front of the center of their respective platoons. The captain aligns the front rank, rear rank, and file closers, takes post 3 paces in front of the right guide, facing to the left and commands: **1. FRONT, 2. PREPARE FOR INSPECTION.**

At the second command the lieutenants carry saber; the captain returns saber and inspects them, after which they face about, order saber, and stand at ease; upon the completion of the inspection they carry saber, face about, and order saber. The captain may direct the lieutenants to accompany or assist him, in which case they return saber and, at the close of the inspection, resume their posts in front of the company, draw and carry saber.

Having inspected the lieutenants, the captain proceeds to the right of the company. Each man, as the captain approaches him executes **inspection arms**.

The captain takes the piece, grasping it with his right hand just below the lower band, the man dropping his hands; the captain inspects the piece, and, with the hand and piece in the same position as in receiving it, hands it back to the man, who takes it with the left hand at the balance and executes **order arms**.

As the captain returns the piece the next man executes **inspection arms**, and so on through the company.

Should the piece be inspected without handling, each man executes **order arms** as soon as the captain passes to the next man.

The inspection is from right to left in front, and from left to right in rear of each rank and of the line of file closers.

When approached by the captain the first sergeant executes **inspection saber**. Enlisted men armed with the pistol execute **inspection pistol** by drawing the pistol from the holster and holding it diagonally across the body, barrel up, and 6 inches in front of the neck, muzzle pointing up and to the left. The pistol is returned to the holster as soon as the captain passes. [Pg 192d]

Upon completion of the inspection the captain takes post facing to the left in front of the right guide and on line with the lieutenants and commands: **1. CLOSE RANKS, 2. MARCH.**

At the command march the lieutenants resume their posts in line; the rear rank closes to 40 inches, each man covering his file leader; the file closers close to 2 paces from the rear rank.

MANUAL OF PHYSICAL TRAINING

(EXTRACTS)

METHODS

825. In the employment of the various forms of physical training it is necessary that well-defined methods should be introduced in order that the object of this training may be attained in the most thorough and systematic manner. Whenever it is possible this work should be conducted out of doors. In planning these methods the following factors must be considered:

- (a) The condition and physical aptitude of the men.
- (b) The facilities.
- (c) The time.

The question of the *physical aptitude* and *general condition*, etc., of the men is a very important one, and it should always determine the nature and extent of the task expected of them; never should the work be made the determining factor. In general, it is advisable to divide the men into three classes, viz., the recruit class, the intermediate class, and the advanced class. The work for each class should fit the capabilities of the members of that class and in every class it should be arranged progressively.

Facilities are necessarily to be considered in any plan of instruction, but as most posts are now equipped with better than average facilities the plan laid down in this Manual will answer all purposes.

Time is a decidedly important factor, and no plan can be made unless those in charge of this work know exactly how much time they have at their disposal. During the suspension of drills five periods a week, each of 45 minutes duration, should be devoted to physical training; during the drill period a 15-minute drill in setting-up exercises should be ordered on drill days. The time of day, too, is important. *When possible, these drills should be held in the morning about two hours after breakfast, and at no time should they be held immediately before or after a meal.*

Insist upon accurate and precise execution of every movement. By doing so those other essential qualities, besides strength and endurance—activity, agility, gracefulness, and accuracy—will also be developed.

Exercises which require activity and agility, rather than those that require strength only, should be selected.

It should be constantly borne in mind that these exercises are the means and not the end; and if there be a doubt in the mind of the instructor as to the effect of an exercise, it is always well to err upon the side of safety. *Underdoing is rectifiable; overdoing is often not.* The object of this work is not the development of expert gymnasts, but the development of physically sound men by means of a system in which the chances of bodily injury are reduced to a minimum. When individuals show a special aptitude for gymnastics they may be encouraged, within limits, to improve this ability, but never at the expense of their fellows.

[Pg 194]

The drill should be made as attractive as possible, and this can best be accomplished by employing the mind as well as the body. The movements should be as varied as possible, thus constantly offering the men something new to make them keep their minds on their work. A movement many times repeated presents no attraction and is executed in a purely mechanical manner, which should always be discountenanced.

Short and frequent drills should be given in preference to long ones, which are liable to exhaust all concerned, and exhaustion means lack of interest and benefit. All movements should be carefully explained, and, if necessary, illustrated by the instructor.

The lesson should begin with the less violent exercises, gradually working up to those that are more so, then gradually working back to the simpler ones, so that the men at the close of the drill will be in as nearly a normal condition as possible.

When one portion of the body is being exercised, care should be taken that the other parts remain quiet as far as the conformation of the body will allow. The men must learn to exercise any one part of the body independent of the other part.

Everything in connection with physical training should be such that the men look forward to it with pleasure, not with dread, for the mind exerts more influence over the human body than all the gymnastic paraphernalia that was ever invented.

Exercise should be carried on as much as possible in the open air; at all times in pure, dry air.

Never exercise the men to the point of exhaustion. If there is evidence of panting, faintness, fatigue, or pain, the exercise should be stopped at once, for it is nature's way of saying "too much."

By constant practice the men should learn to breathe slowly through the nostrils during all

exercises, especially running.

A fundamental condition of exercise is unimpeded respiration. Proper breathing should always be insisted upon; "holding the breath" and breathing only when it can no longer be held is injurious. Every exercise should be accompanied by an unimpeded and, if possible, by an uninterrupted act of respiration, the inspiration and respiration of which depends to a great extent upon the nature of the exercise. Inhalation should always accompany that part of an exercise which tends to elevate and distend the thorax—as raising arms over head laterally, for instance; while that part of an exercise which exerts a pressure against the walls of the chest should be accompanied by exhalation, as for example, lowering arms laterally from shoulders or overhead.

If after exercising, the breathing becomes labored and distressed, it is an unmistakable sign that the work has been excessive. Such excessiveness is not infrequently the cause of serious injury to the heart and lungs or to both. In cases where exercise produces palpitation, labored respiration, etc., it is advisable to recommend absolute rest, or to order the execution of such exercises as will relieve the oppressed and overtaxed organ. Leg exercises slowly executed will afford great relief. By drawing the blood from the upper to the lower extremities they equalize the circulation, thereby lessening the heart's action and quieting the respiration.

[Pg 195]

Never exercise immediately after a meal; digestion is more important at this time than extraneous exercise.

Never eat or drink immediately after exercise; allow the body to recover its normal condition first, and the most beneficial results will follow. If necessary, pure water, not too cold, may be taken in small quantities, but the exercise should be continued, especially if in a state of perspiration.

Never, if at all possible, allow the underclothing to dry on the body. Muscular action produces an unusual amount of bodily heat; this should be lost gradually, otherwise the body will be chilled; hence, after exercise, never remove clothing to cool off, but, on the contrary, wear some wrap in addition. In like manner, be well wrapped on leaving the gymnasium.

Cold baths, especially when the body is heated, as in the case after exercising violently, should be discouraged. In individual instances such baths may appear apparently beneficial, or at least not injurious; in a majority of cases, however, they can not be used with impunity. Tepid baths are recommended. When impossible to bathe, the flannels worn while exercising should be stripped off; the body sponged with tepid water, and then rubbed thoroughly with coarse towels. After such a sponge the body should be clothed in clean, warm clothing.

Flannel is the best material to wear next to the body during physical drill, as it absorbs the perspiration, protects the body against drafts and, in a mild manner, excites the skin. When the conditions permit it the men may be exercised in the ordinary athletic costume, sleeveless shirt, flappers, socks, and gymnasium shoes.

COMMANDS—SETTING-UP EXERCISES

COMMANDS

826. There are two kinds of commands:

The preparatory indicates the movement to be executed.

The command of execution causes the execution.

In the command: **1. Arms forward, 2. RAISE**, the words **Arms forward** constitute the preparatory command, and **RAISE** the command of execution. Preparatory commands are printed in **bold face**, and those of execution in **CAPITALS**.

The tone of command is animated, distinct, and of a loudness proportioned to the number of men for whom it is intended.

The various movements comprising an exercise are executed by commands and, unless otherwise indicated, the continuation of an exercise is carried out by repeating the command, which usually takes the form of numerals the numbers depending upon the number of movements, that an exercise comprises. Thus, if an exercise consists of two movements, the counts will be one, two; or if it consists of eight movements, the counts will be correspondingly increased; thus every movement is designated by a separate command.

Occasionally, especially in exercises that are to be executed slowly, words rather than numerals are used, and these must be indicative of the nature of the various movements.

[Pg 196]

In the continuation of an exercise the preparatory command is explanatory, the command of execution causes the execution and the *continuation is caused by a repetition of numerals* denoting the number of movements required, or of words describing the movements if words are used. The numerals or words preceding the command **halt** should always be given with a rising inflection on the first numeral or word of command of the last repetition of the exercise in order

to prepare the men for the command **halt**.

For example:

1. Arms to thrust, 2. RAISE, 3. Thrust arms upward, 4. EXERCISE, ONE, TWO, ONE, TWO, ONE, HALT; the rising inflection preparatory to the command halt being placed on the "one" preceding the "**halt**."

Each command must indicate, by its tone, how that particular movement is to be executed; thus, if an exercise consists of two movements, one of which is to be energized, the command corresponding to that movement must be emphasized.

Judgment must be used in giving commands, for rarely is the cadence of two movements alike; and a command should not only indicate the cadence of an exercise, but also the nature of its execution.

Thus, many of the arm exercises are short and snappy; hence the command should be given in a smart tone of voice, and the interval between the commands should be short.

The leg exercises can not be executed as quickly as those of the arms; therefore, the commands should be slightly drawn out and follow one another in slow succession.

The trunk exercises, owing to the deliberateness of execution, should be considerably drawn out and follow one another in slow succession.

The antagonistic exercises, where one group of muscles is made to antagonize another, tensing exercises, the commands are drawn still more. In these exercises words are preferable to numerals. In fact it should be the object of the instructor to convey to the men, by the manner of his command, exactly the nature of the exercise.

All commands should be given in a clear and distinct tone of voice, articulation should be distinct, and an effort should be made to cultivate a voice which will inspire the men with enthusiasm and tend to make them execute the exercises with willingness, snap, and precision. It is not the volume, but the quality, of the voice which is necessary to successful instruction.

THE POSITION OF ATTENTION

827. This is the position an unarmed dismounted soldier assumes when in ranks. During the setting-up exercises, it is assumed whenever the command attention is given by the instructor.

Having allowed his men to rest, the instructor commands: **1. Squad, 2. ATTENTION.** [Figs. A and B.](#)

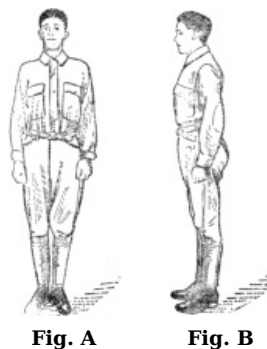

[Pg 197]

The words **class, section, or company** may be substituted for the word "squad."

At the command **attention**, the men will quickly assume and retain the following position:

Heels on same line and as near each other as the conformation of the man permits.

Feet turned out equally and forming an angle of about 45 degrees.

Knees straight without stiffness.

The body erect on the hips, the spine extended throughout its entire length.

The shoulders falling naturally, are forced back until they are square.

Chest arched and slightly raised.

The arms hang naturally; thumbs along seams of trousers; back of hands out and elbows turned back.

Head erect, chin drawn in so that the axis of the head and neck is vertical; eyes straight to the front and, when the nature of the terrain permits it, fixed on an object at their own height.

Too much attention can not be given to this position, and instructors are cautioned to insist that the men accustom themselves to it. As a rule, it is so exaggerated that it not only becomes ridiculous, but positively harmful. The men must be taught to assume a natural and graceful position, one from which all rigidity is eliminated and from which action is possible without first relaxing muscles that have been constrained in an effort to maintain the position of attention. In other words, coordination rather than strength should be depended upon.

In the position described the weight rests principally upon the balls of the feet, the heels resting lightly upon the ground.

The knees are extended easily, but never locked.

The body is now inclined forward until the front of the thighs is directly over the point of the toes; the hips are square and the waist is extended by the erection of the entire spine, but never to such a degree that mobility of the waist is lost.

In extending the spine, the chest is naturally arched and the abdomen is drawn in, but never to the extent where it interferes with respiration.

In extending the spinal column, the shoulders must not be raised, but held loosely in normal position and forced back until the points of the shoulders are at right angles with an anterior-posterior plane running through the shoulders.

The chin should be square; i. e., horizontal and forced back enough to bring the neck in a vertical plane; the eyes fixed to the front and the object on which they are fixed must be at their own height whenever the nature of the terrain permits it.

When properly assumed, a vertical line drawn from the top of the head should pass in front of the ear, just in front of the shoulder and of the thigh, and find its base at the balls of the feet.

[Pg 198]

All muscles should be contracted only enough to maintain this position, which at all times should be a lithesome one, that can be maintained for a long period without fatigue—one that makes for activity and that is based upon a correct anatomical and physiological basis.

Instructors will correct the position of attention of every man individually and they will ascertain, when the position has been properly assumed, whether the men are "on their toes," i. e., carrying the weight on the balls of the feet, whether they are able to respire properly, and whether they find a strain across the small of the back, which should be as flat as possible. This should be repeated until the men are able to assume the position correctly without restraint or rigidity.

At the command **rest** or **at ease** the men, while carrying out the provisions of the drill regulations, should be cautioned to avoid assuming any position that has a tendency to nullify the object of the position of attention; standing on leg for instance; allowing the shoulders to slope forward; drooping the head; folding arms across chest, etc. The weight should always be distributed equally upon both legs; the head, trunk, and shoulders remain erect and the arms held in a position that does not restrict the chest or derange the shoulders. The positions illustrated here have been found most efficacious. [Figs. C.](#) and [D.](#)



Fig. C

Fig. D

FORMATIONS

828. The men form in a single or double rank, the tallest men on the right.

The instructor commands: **1. Count off.**

At this command, all except the right file execute "**eyes right**" and, beginning on the right, the men in each rank count 1, 2, 3, 4; each man turns his head and eyes to the front as he counts.

The instructor then commands: **1. Take distance, 2. MARCH, 3. Squad, 4. HALT.**

At the command **march**, No. 1 of the front rank moves straight to the front; Nos. 2, 3, and 4 of the front and Nos. 1, 2, 3, and 4 of the rear rank in the order named move straight to the front, each stepping off, so as to follow the preceding man at four paces; the command halt is given when all have their distances.

If it is desired that a less distance than four paces be taken, the distance desired should be indicated in the preparatory command. The men of the squad may be caused to cover No. 1 front rank by command cover.

The instructor then commands: **1. Right (left), 2. FACE, 3. COVER.**

At these commands the men face in the direction indicated and cover in file.

To assemble the squad the instructor commands: **1. Right (left), 2. FACE, 3. Assemble, 4. MARCH.**

After facing and at command march, No. 1 of the front rank stands fast, the other members of both ranks resuming their original positions, or for convenience in the gymnasium they may be assembled to the rear, in which case the assemblage is made on No. 4 of the rear rank.

Unless otherwise indicated, the guide is **always right**.

SPECIAL TRAINING

829. In addition to the regular squad or class work instructors should, when they notice a physical defect in any man, recommend some exercise which will tend to correct it.

The most common physical defects and corresponding corrective exercises are noted here.

DROOPING HEAD

830. Exercise the muscles of the neck by bending, turning, and circling the head, muscles tense.

ROUND AND STOOPED SHOULDERS

831. Stretch arms sideward from front horizontal, turning palms upward, muscles tense.

Swing arms forward and backward, muscles relaxed.

Circle arms forward and backward slowly, energize backward motion, muscles tense; forward motion with muscles relaxed.

Circle shoulders backward, move them forward first, then raise them, then move them backward as far as possible in the raised position, muscles tense, and then lower to normal position, muscles relaxed.

WEAK BACK

832. Bend trunk forward as far as possible and erect it slowly.

Bend trunk forward, back arched and head thrown back.

Bend trunk sideward, without moving hips out of normal position, right and left.

Lie on floor, face down, and raise head and shoulders.

WEAK ABDOMEN

833. Circle trunk right or left.

Bend trunk backward or obliquely backward.

Bend head and trunk backward without moving hips out of normal plane.

Lie on floor, face up, and raise head and shoulders slightly; or to sitting position or raise legs slightly; or to a vertical position.

To increase depth and width of chest

Arm stretchings, sideward and upward, muscles tense.

Same, with deep inhalations.

Arm swings and arm circles outward, away from the body.

Raise extended arms over head laterally and cross them behind the head.

Breathing exercises in connection with arm and shoulder exercises.

STARTING POSITIONS

834. In nearly all the arm exercises it is necessary to hold the arms in some fixed position from which the exercises can be most advantageously executed, and to which position the arms are again returned upon completing the exercise. These positions are termed **starting positions**; and though it may not be absolutely necessary to assume one of them before or during the employment of any other portion of the body, it is advisable to do so, since they give to the exercise a finished, uniform, and graceful appearance.

In the following positions, at the command **down**, resume the **attention**. Practice in assuming the starting position may be had by repeating the commands of execution, such as **raise, down**.

835. While the exercises given below have been grouped for convenient reference, into arm exercises, trunk exercises, leg exercises, etc., one entire group *must not* be given and then the next and so on.

Always bear in mind that the best results are obtained when those exercises which affect the extensor muscles chiefly are followed by those affecting the flexors; i. e., flexion should always be followed by extension, or vice versa. It is also advisable that a movement requiring a considerable amount of muscular exertion should be followed by one in which this exertion is reduced to a minimum. As a rule, especially in the setting-up exercises, one portion of the body should not be exercised successively; thus, arm exercises should be followed by a trunk exercise, and that in turn by a leg, shoulder, and neck exercise.

ARM EXERCISES

836. Intervals having been taken and attention assumed, the instructor commands:

1. Arms forward, 2. RAISE, 3. Arms, 4. DOWN. [Fig. 1.](#)



Fig. 1

At the command **raise**, raise the arms to the front smartly, extended to their full length, till the hands are in front of and at the height of the shoulders, palms down, fingers extended and joined, thumbs under forefingers. At **Arms, DOWN**, resume position of attention.

1. Arms upward 2. RAISE, 3. Arms, 4. DOWN. [Fig. 2.](#)



Fig. 2

At the command **raise**, raise the arms from the sides, extended to their full length, with the forward movement, until they are vertically overhead, backs of hands turned outward, fingers as in 1.

This position may also be assumed by raising the arms laterally until vertical. The instructor cautions which way he desires it done.

1. Arms backward, 2. CROSS, 3. Arms, 4. DOWN. [Fig. 3.](#)



Fig. 3

At the command **cross**, the arms are folded across the back; hands grasping forearms.

1. Arms to thrust, 2. RAISE, 3. Arms, 4. DOWN. [Fig. 4.](#)



Fig. 4

At the command **raise**, raise the forearms to the front until horizontal, elbow forced back, upper arms against the chest, hands tightly closed, knuckles down.

1. Hands on hips, 2. PLACE, 3. Arms, 4. DOWN. [Fig. 5.](#)



Fig. 5

At the command **place**, place the hands on the hips, the finger tips in line with trouser seams; fingers extended and joined, thumbs to the rear, elbows pressed back.

Combination of arm exercises

1. Arms to thrust, 2. RAISE, 3. THRUST ARMS FORWARD; SWING THEM SIDWARD, FORWARD, AND BACK TO POSITION.

Four counts; repeat 8 to 10 times.

The arms are thrust forward, then relaxed and swung sideward, then forward and finally brought back to position, pressing elbows well to the rear; execute moderately fast; exhale on the first and third and inhale on the second and fourth counts.

SETTING-UP EXERCISES

[Pg 202]

837. As has been stated previously, the setting-up exercises form the basis upon which the entire system of physical training in the service is founded. Therefore too much importance can not be attached to them. Through the number and variety of movements they offer it is possible to develop the body harmoniously with little if any danger of injurious results. They develop the muscles and impart vigor and tone to the vital organs and assist them in their functions; they develop endurance and are important factors in the development of smartness, grace, and precision. They should be assiduously practiced. The fact that they require no apparatus of any description makes it possible to do this out of doors or even in the most restricted room, proper sanitary conditions being the only adjunct upon which their success is dependent. No physical training drill is complete without them. They should always precede the more strenuous forms of training, as they prepare the body for the greater exertion these forms demand.

At the discretion of instructors these exercises may be substituted by others of a similar

character. Instructors are cautioned, however, to employ all the parts of the body in every lesson and to suit the exercise as far as practicable to the natural function of the particular part of the body which they employ.

In these lessons only the preparatory command is given here; the command of execution, which is invariably **Exercise**, and the commands of continuance, as well as the command to discontinue, having been explained are omitted.

Every preparatory command should convey a definite description of the exercise required; by doing so long explanations are avoided and the men will not be compelled to memorize the various movements.

RECRUIT INSTRUCTION

First Series

Position of attention, from **at ease** and **rest**.

Starting position, [Figs. 1](#) to 5.

TRUNK EXERCISES

838. 1. Hands on hips, 2. PLACE, 3. QUARTER BEND TRUNK FORWARD.

Two counts; repeat 8 to 10 times, [Fig. 6](#).



Fig. 6

The trunk is inclined forward at the waist about 45° and then extended again; the hips are as perpendicular as possible; execute slowly; exhale on first and inhale and raise chest on second count.

By substituting the words *half* or *full* for the word *quarter* in the command, the half bend, [Fig. 7](#), and full bend exercise can be given.

[Pg 203]



Fig. 7

1. Hands on hips, 2. PLACE, 3. BEND TRUNK BACKWARD.

Two counts; repeat 6 to 8 times, [Fig. 8](#).



Fig. 8

The trunk is bent backward as far as possible; head and shoulders fixed; knees extended; feet firmly on the ground; hips as nearly perpendicular as possible; in recovering care should be taken not to sway forward; execute slowly; inhale on first and exhale on second count.

1. Hands on hips, 2. PLACE, 3. BEND TRUNK SIDWARD, RIGHT OR LEFT.

Two counts; repeat 6 to 8 times, [Fig. 9](#).



Fig. 9

The trunk, stretched at the waist, is inclined sideward as far as possible; head and shoulders fixed; knees extended and feet firmly on the ground; execute slowly; inhale on first and exhale on second count.

If an additional exercise is desired, by commanding: **CIRCLE TRUNK RIGHT or LEFT** a combination of the above trunk exercises is obtained.

LEG EXERCISES

839. 1. Hands on hips, 2. PLACE, 3. QUARTER BEND KNEES.

Two counts; repeat 8 to 10 times, [Fig. 10](#).



Fig. 10

The knees are flexed until the point of the knee is directly over the toes; whole foot remains on ground; heels closed; head and body erect; execute moderately fast, emphasizing the extension; breathe naturally.

By substituting the words *half* or *full* for the word quarter in the command the half bend and full bend, [Fig. 11](#), exercises can be given.



Fig. 11

1. Hands on hips, 2. PLACE, 3. RAISE KNEE.

Two counts; repeat 10 to 12 times. [Fig. 12](#).



Fig. 12

The thigh and knee are flexed until they are at right angles, thigh horizontal: toes depressed; the right knee is raised at **one** and the left at **two**; trunk and head erect; execute in cadence of quick time; breathe naturally.

SHOULDER EXERCISE

840. 1. Arms to thrust, 2. RAISE, 3. MOVE SHOULDERS FORWARD, UP, BACK, AND DOWN.

Four counts; repeat 8 to 10 times.

The shoulders are relaxed and brought forward; in that position they are raised: then they are forced back without lowering them; and then they are dropped back to position; execute slowly; exhale on the first; inhale on the second and third and exhale on the last count.

NECK EXERCISE

841. 1. Arms to thrust, 2. RAISE, 3. TURN HEAD RIGHT, OR LEFT.

Two counts; repeat 6 to 10 times, [Fig. 13](#).



Fig. 13

The head, chin square, is turned to the right, or left as far as possible, muscles of the neck being stretched; shoulders remain square; execute slowly; breathe naturally.

To vary this exercise the head may be *bent forward and to the rear* by substituting the proper commands.

[Pg 205]

BREATHING EXERCISE

842. 1. Breathing exercise, 2. INHALE, 3. EXHALE.

At **inhale** the arms are stretched forward overhead and the lungs are inflated; at **exhale** the arms are lowered laterally and the lungs deflated; execute slowly; repeat four times.

TOE EXERCISE

843. 1. Arms backward, 2. CROSS, 3. RISE ON TOES.

Two counts; repeat 8 to 10 times, [Fig. 14](#).



Fig. 14

The body is raised smartly until the toes and ankles are extended as much as possible; heels closed; head and trunk erect; in recovering position heels are lowered gently; breathe naturally.

COMBINATION EXERCISE

844. This exercise brings into play practically all of the muscles that have been used in the preceding exercises.

1. LEANING REST IN FOUR COUNTS.

Repeat 6 to 8 times, [Figs. 15, 16](#).



Fig. 15

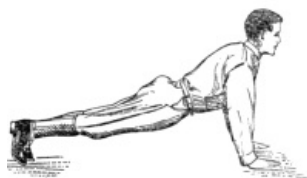

Fig. 16

At **one** knees are bent to squatting position, hands on the ground between knees; at **two** the legs are extended backward to the leaning rest; at **three** the first position is resumed, and at **four** the position of attention; hands should be directly under shoulders; back arched; knees straight; head fixed; execute moderately fast; breathe naturally.

WALKING AND MARCHING

[Pg 206]

845. The length of the full step in quick time is 30 inches, measured from heel to heel, and the cadence is at the rate of 120 steps per minute.

Proper posture and carriage have ever been considered very important in the training of soldiers. In marching, the head and trunk should remain immobile, but without stiffness; as the left foot is carried forward the right forearm is swung forward and inward obliquely across the body until the thumb, knuckles being turned out, reaches a point about the height of the belt plate. The upper arm does not move beyond the perpendicular plane while the forearm is swung forward, though the arm hangs loosely from the shoulder joint. The forearm swing ends precisely at the moment the left heel strikes the ground; the arm is then relaxed and allowed to swing down and backward by its own weight until it reaches a point where the thumb is about the breadth of a hand to the rear of the buttocks. As the right arm swings back, the left arm is swung forward with the right leg. The forward motion of the arm assists the body in marching by throwing the weight forward and inward upon the opposite foot as it is planted. The head is held erect; body well stretched from the waist; chest arched; and there should be no rotary motion of the body about the spine.

As the leg is thrown forward the knee is smartly extended, the heel striking the ground first.

The instructor having explained the principles and illustrated the step and arm swing, commands: **1. Forward, 2. MARCH**—and to halt the squad he commands: **1. Squad, 2. HALT.**

In executing the setting-up exercises on the march the cadence should at first be given slowly and gradually increased as the men become more expert; some exercises require a slow and others a faster pace; it is best in these cases to allow the cadence of the exercise to determine the cadence of the step.

The men should march in a single file at proved intervals. The command that causes and discontinues the execution should be given as the left foot strikes the ground.

On the march, to discontinue the exercise, command: **1. Quick time, 2. MARCH**, instead of **HALT**, as when at rest.

All of the arm, wrist, finger, and shoulder exercises, and some of the trunk and neck, may be executed on the march by the same commands and means as when at rest.

The following leg and foot exercises are executed at the command march; the execution always beginning with the left leg or foot.

1. **1. On toes, 2. MARCH.**
2. **1. On heels, 2. MARCH.**
3. **1. On right heel and left toe, 2. MARCH.**
4. **1. On left heel and right toe, 2. MARCH.**
5. **1. On toes with knees stiff, 2. MARCH.**
6. **1. Swing extended leg forward, ankle high, 2. MARCH.**
7. **1. Swing extended leg forward, knee high, 2. MARCH.**
8. **1. Swing extended leg forward, waist high, 2. MARCH.**
9. **1. Swing extended leg forward, shoulder high, 2. MARCH.**
10. **1. Raise heels, 2. MARCH.**
11. **1. Raise knees, thigh horizontal, 2. MARCH.**
12. **1. Raise knees, chest high, 2. MARCH.**
13. **1. Circle extended leg forward, ankle high, 2. MARCH.**
14. **1. Circle extended leg forward, knee high, 2. MARCH.**
15. **1. Circle extended leg forward, waist high, 2. MARCH.**
16. **1. Swing extended leg backward, 2. MARCH.**
17. **1. Swing extended leg sideward, 2. MARCH.**
18. **1. Raise knee and extend leg forward, 2. MARCH.**
19. **1. Raise heels and extend leg forward, 2. MARCH.**

[Pg 207]

DOUBLE TIMING

846. The length of the step in double time is 36 inches; the cadence is at the rate of 180 steps per minute. To march in double time the instructor commands: **1. Double time, 2. MARCH.**

If at a halt, at the first command shift the weight of the body to the right leg. At the command **march** raise the forearms, fingers closed; to a horizontal position along the waist line; take up an easy run with the step and cadence of double time, allowing a natural swinging motion to the arms inward and upward in the direction of the opposite shoulder.

In marching in quick time, at the command **march**, given as either foot strikes the ground, take one step in quick time, and then step off in double time.

When marching in double time and in running the men breathe as much as possible through the nose, keeping the mouth closed.

A few minutes at the beginning of the setting-up exercises should be devoted to double timing. From lasting only a few minutes at the start it may be gradually increased, so that daily drills should enable the men at the end of five or six months to double time 15 or 20 minutes without becoming fatigued or distressed.

After the double time the men should be marched for several minutes at quick time; after this the instructor should command:

1. Route step, 2. MARCH.

In marching at route step, the men are not required to preserve silence nor keep the step; if marching at proved intervals, the latter is preserved.

To resume the cadence step in quick time, the instructor commands: **1. Squad, 2. ATTENTION.**

Great care must be exercised concerning the duration of the double time and the speed and duration of the run. The demands made Upon the men should be increased gradually.

When exercise rather than distance is desired, the running should be done on the balls of the feet, heels raised from the ground.

DOUBLE TIMING EXERCISES

[Pg 208]

While the men are double timing the instructor may vary the position of the arms by commanding:

1. **1. Arms forward, 2. RAISE.**
2. **1. Arms sideward, 2. RAISE.**
3. **1. Arms upward, 2. RAISE.**
4. **1. Hands on hips, 2. PLACE.**
5. **1. Hands on shoulders, 2. PLACE.**
6. **1. Arms forward, 2. CROSS.**
7. **1. Arms backward, 2. CROSS.**

At the command **down**, the double-time position for the arms and hands is resumed.

RIFLE EXERCISES

847. The object of these exercises, which may also be performed with wands or bar bells, is to develop the muscles of the arms, shoulders, and back so that the men will become accustomed to the weight of the piece and learn to wield it with that "handiness" so essential to its successful use. When these exercises are combined with movements of the various other parts of the body, they serve as a splendid, though rather strenuous, method for the all-round development of the men. As the weight of the piece is considerable, instructors are cautioned to be reasonable in their demands. Far better results are obtained if these exercises are performed at commands than when they are grouped and performed for spectacular purposes.

All the exercises start from the starting position, which is the low extended arm horizontal position in front of the body, arms straight; the right hand grasping the small of the stock and the left hand the barrel; the knuckles turned to the front and the distance between the hands slightly greater than the width of the shoulders. [Fig. 17](#).



Fig. 17

This position is assumed at the command: **1. Starting, 2. POSITION**; at the command **position** the piece is brought to the port and lowered to the front horizontal snappily.

To recover the position of order, command: **1. Order, 2. Arms**; the piece is first brought to the port and then to the order.

RIFLE DRILL COMBINATION

The following exercises consist of four movements, the third position always corresponding to the first position and the fourth to the starting position. When performed as a musical drill, the instructions laid down in that lesson are applicable here.

All exercises begin and end with the first or starting position. [Fig. 17](#).

[Pg 209]

The form of command is, for example:

(Being at the starting position)

1. First group, 2. FIRST, EXERCISE;

1. Second group, 2. THIRD, EXERCISE;

Etc.,

Etc.

FIRST GROUP

848. *First Exercise*



Fig. 18



**Fig.
19**

Counts

1-2.

Raise piece to bent arm front horizontal, shoulder high, and stride forward right, [Fig. 18](#);

- 3-4. Face to the left on both heels and extend piece upward, [Fig. 19](#);
- 5-6. Resume first position;
- 7-8. Resume starting position.
Repeat left, right, left.

849. Second Exercise



Fig. 20



Fig. 21

- 1-2. Raise piece to extended high horizontal, and stride sideward right, [Fig. 20](#);
- 3-4. Bend right knee and lower piece to left horizontal, [Fig. 21](#);
- 5-6. Resume first position;
- 7-8. Resume starting position.
Repeat left, right, left.

850. Third Exercise

[Pg 210]



Fig. 22



Fig. 23

- 1-2. Raise piece to high side perpendicular on the left, left hand up, and stride backward right, [Fig. 22](#);
- 3-4. Face about on heels and swing piece down and up to high side perpendicular on the right, [Fig. 23](#);
- 5-6. Resume first position;
- 7-8. Resume starting position.
Repeat left, right, left.

851. Fourth Exercise



Fig. 24



Fig. 25

- 1-2. Raise piece to extended high horizontal, and stride obliquely forward right, [Fig. 24](#);
- 3-4. Face about on heels and lower piece to horizontal on shoulders; [Fig. 25](#);
- 5-6. Resume first position;
- 7-8. Resume starting position.
Repeat left, right, left.

852. First Exercise



Fig. 26



Fig. 27

- 1- Lower piece to front extended horizontal and bend trunk forward, [Fig. 26](#);
- 2.
- 3- Lunge obliquely forward right and raise piece to right oblique, left hand at shoulder, [Fig. 27](#);
- 4.
- 5- Resume first position;
- 6.
- 7- Resume starting position.
8. Repeat left, right, left.

853. Second Exercise



Fig. 28



Fig. 29

- 1- Raise piece to high perpendicular on the left, left hand up, and bend trunk sideward right, [Fig. 28](#);
- 2.
- 3- Lunge sideward right and swing piece down and up to right high perpendicular, right hand up, [Fig. 29](#);
- 4.
- 5- Resume first position;
- 6.
- 7- Resume starting position.
8. Repeat left, right, left.

854. Third Exercise

[Pg 212]

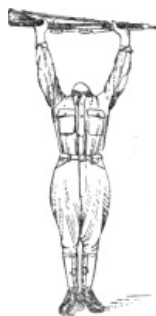

Fig. 30



Fig. 31

- 1-2. Raise piece to high extended arm horizontal and bend trunk backward, [Fig. 30](#);
- 3-4. Lunge forward right, and swing piece to side horizontal, left hand to the rear, [Fig. 31](#);
- 5-6. Resume first position;
- 7-8. Resume starting position.
Repeat left, right, left.

855. Fourth Exercise



Fig. 32



Fig. 33

- 1-2. Raise piece to right high perpendicular and side step position left, [Fig. 32](#);
- 3-4. Lunge sideward left and swing piece to left high perpendicular, [Fig. 33](#);
- 5-6. Resume first position;
- 7-8. Resume starting position.
Repeat left, right, left.

THIRD GROUP

856. First Exercise



Fig. 34



Fig. 35

- 1- 2. Raise piece to front bent horizontal, arms crossed, left over right; lunge sideward right and bend trunk sideward right, [Fig. 34](#);
- 3- 4. Extend right knee and bend trunk to the left, bending left knee and recrossing arms, left over right, [Fig. 35](#);
- 5- 6. Resume first position;
- 7- 8. Resume starting position.
Repeat left, right, left.

[Pg 213]

857. Second Exercise



Fig. 36



Fig. 37

- 1- 2. Raise piece to bent arm horizontal; face right and lunge forward right and bend trunk forward, [Fig. 36](#);
- 3- 4. Raise trunk and turn to the left on both heels and extend piece overhead, [Fig. 37](#);
- 5- 6. Resume first position;
- 7- 8. Resume starting position.
Repeat left, right, left.

858. Third Exercise

[Pg 214]



Fig. 38



Fig. 39

- 1-2. Raise piece to left high horizontal; lunge forward right, [Fig. 38](#);
- 3-4. Bend trunk forward and swing piece to extended low horizontal, [Fig. 39](#);
- 5-6. Resume first position;
- 7-8. Resume starting position.
Repeat left, right, left.

859. Fourth Exercise



Fig. 40



Fig. 41

- 1-2. Raise piece to high extended horizontal and hop to side straddle position, [Fig. 40](#);
- 3-4. Bend trunk forward and swing piece to extended low horizontal, left hand between legs, right hand forward, [Fig. 41](#);
- 5-6. Resume first position;
- 7-8. Resume starting position.
Repeat left, right, left.

GYMNASTIC CONTESTS

860. These exercises are those in which the benefits are lost sight of in the pleasure their attainment provides, which in the case of these contests is the vanquishing of an opponent. The men are pitted against each other in pairs; age, height, weight, and general physical aptitude being the determining factors in the selection.

In the contests in which superiority is dependent upon skill and agility no restrictions need be placed upon the efforts of the contestants; but in those that are a test of strength and endurance it is well to call a contest a "draw," when the men are equally matched and the contest is likely to be drawn out to the point of exhaustion of one or both contestants.

It is recommended that these contests be indulged in once or twice a month and then at the conclusion of the regular drill.

Contests that require skill and agility should alternate with those that depend upon force and endurance. In order to facilitate the instruction a number of pairs should be engaged at the same time.

1. Cane wrestling: The cane to be about an inch in diameter and a yard long, ends rounded. It is grasped with the right hand at the end, knuckles down, and with the left hand, knuckles up, inside of and close to the opponent's right hand. Endeavor is then made to wrest the cane from the opponent. Loss of grip with either hand loses the bout.

2. Cane twisting. Same cane as in 1. Contestants grasp it as in 1, only the knuckles of both hands are up, and the arms are extended overhead. Object: The contestants endeavor to make the cane revolve in their opponent's hand without allowing it to do so in their own. The cane must be forced down.

3. Cane pulling: Contestants sit on the ground, facing each other, legs straight and the soles of

the feet in contact. The cane is grasped as in 2 but close to the feet. Object: To pull the opponent to his feet. The legs throughout the contest must be kept rigid.

4. "Bucked" contest: Contestants sit on the ground "bucked"; i. e., the cane is passed under the knees, which are drawn up, and the arms passed under the cane with the fingers laced in front of the ankles. Object: To get the toes under those of the opponent and roll him over.

5. Single pole pushing: Contestants grasp end of pole, 6 feet long and 2 inches thick, and brace themselves. Object: To push the opponent out of position.

6. Double pole pushing: The poles are placed under the arms close to the arm pits, ends projecting. Object: Same as in 5.

7. Double pole pulling: Position as in 6 but standing back to back. Object: To pull the opponent out of position.

8. "Cock fight": Contestants hop on one leg with the arms folded closely over the chest. Object: by butting with the fleshy part of the shoulder without raising the arms, or by dodging to make the opponent change his feet or touch the floor with his hand or other part of his body.

9. One-legged tug of war: Contestants hop on one leg and grasp hands firmly. Object: To pull the opponent forward or make him place the raised foot on the floor.

10. The "siege": One contestant stands with one foot in a circle 14 inches in diameter, the other foot outside, and the arms folded as in 8. Two other contestants, each hopping on one leg, endeavor to dislodge the one in the circle by butting him with the shoulder. The besieged one is defeated in case he raises the foot in the circle, or removes it entirely from the circle. The besiegers are defeated in case they change feet or touch the floor as in 8. As soon as either of the latter is defeated his place is immediately filled, so that there are always two of them. The besieged should resort to volting, ducking, etc., rather than to depend upon his strength.

[Pg 216]

11. One-armed tug: Contestants stand facing each other; right hands grasped, feet apart. Object: Without moving feet, to pull the opponent forward. Shifting the feet loses the bout.

12. "Tug royal": Three contestants stand facing inward and grasp each other's wrists securely with their feet outside a circle about three feet in diameter. Object: by pulling or pushing to make one of the contestants step inside of the circle.

13. Indian wrestling: Contestants lie upon the ground face up, right shoulders in close contact, right elbows locked; at one the right leg is raised overhead and lowered, this is repeated at two, and at three the leg is raised quickly and locked with the opponent's right leg. Object: to roll him over by forcing his leg down.

14. Medicine ball race. Teams of five or six men are organized and a track for each team is marked out. This track consists of marks on the floor or ground at distances of 4 yards. On each of these marks stands a man with legs apart, the team forming a column of files. At "ready," "get set," the contestants prepare for the race, and at "go," the first man in the column rolls a medicine ball, which he has on the floor in front of him, through his legs to No. 2, he in turn rolls it to 3, etc., when it reaches the last man he picks it up and runs to the starting place with it and, the others all having shifted back one mark, the rolling is repeated. This continues until the first man brings the ball back to the starting place and every man is in his original position. The ball should be kept rolling: each man, as it comes to him, pushing it on quickly. Any ball about 9 inches in diameter will answer; it may be made of strong cloth and stuffed with cotton waste.

CHAPTER IV

[Pg 217]

SIGNALING

Signals and Codes

General Service Code. (International Morse Code.)

861. Used for all visual and sound signaling, radiotelegraphy, and on cables using siphon recorders, used in communicating with Navy.

A	•	—		
B	—	•	•	•
C	—	•	—	•
D	—	•	•	
E	•			

F	•	•	-	•
G	-	-	•	
H	•	•	•	•
I	•	•		
J	•	-	-	-
K	-	•	-	
L	•	-	•	•
M	-	-		
N	-	•		
O	-	-	-	
P	•	-	-	•
Q	-	-	•	-
R	•	-	•	
S	•	•	•	
T	-			
U	•	•	-	
V	•	•	•	-
W	•	-	-	
X	-	•	•	-
Y	-	•	-	-
Z	-	-	•	•

NUMERALS

1	•	-	-	-	-
2	•	•	-	-	-
3	•	•	•	-	-
4	•	•	•	•	-
5	•	•	•	•	•
6	-	•	•	•	•
7	-	-	•	•	•
8	-	-	-	•	•
9	-	-	-	-	•
0	-	-	-	-	-

PUNCTUATION

Period	•	•	•	•	•	•	
Comma	•	-	•	-	•	-	•
Interrogation	•	•	-	-	•	•	

THE MORE IMPORTANT CONVENTIONAL FLAG SIGNALS

For communication between the firing line and the reserve or commander in rear. In transmission, their concealment from the enemy's view should be insured. In the absence of signal flags the headdress or other substitute may be used.

(See [par. 96](#) for the signals.)

Wigwag

Signaling by flag, torch, hand lantern, or beam of searchlight (without shutter)^[6]

862. 1. There is one position and there are three motions. The position is with flag or other appliance held vertically, the signalman facing directly toward the station with which it is desired to communicate. The first motion (the dot) is to the right of the sender, and will embrace an arc of 90°, starting with the vertical and returning to it, and will be made in a plane at right angles to the line connecting the two stations. The second motion (the dash) is a similar motion to the left

of the sender. The third motion (front) is downward directly in front of the sender and instantly returned upward to the first position. This is used to indicate a pause or conclusion.

2. The beam of the searchlight, though ordinarily used with the shutter like the heliograph, may be used for long-distance signaling, when no shutter is suitable or available, in a similar manner to the flag or torch, the first position being a vertical one. A movement of the beam 90° to the right of the sender indicates a dot, a similar movement to the left indicates a dash; the beam is lowered vertically for front.

3. To use the torch or hand lantern, a footlight must be employed as a point of reference to the motion. The lantern is more conveniently swung out upward to the right of the footlight for a dot, to the left for a dash, and raised vertically for front.

4. To call a station, make the call letter until acknowledged, at intervals giving the call or signal of the calling station. If the call letter of a station is unknown, wave flag until acknowledged. In using the searchlight without shutter throw the beam in a vertical position and move it through an arc of 180° in a plane at right angles to the line connecting the two stations until acknowledged. To acknowledge a call, signal "Acknowledgment (or) I understand (—front)" followed by the call letter of the acknowledging station.

Notes on Wig-wagging

5. In order to avoid the flag wrapping itself about the staff, stand facing the receiving station, with feet apart. Hold the staff with the left hand at butt and right hand 24 inches from end. In moving flag to the right, bring it down with an outward and inward sweep, and then return it to the vertical. When the tip is farthest down the staff inclines to the right front and as the flag is brought upward it is swept inward and upwards and as it approaches the vertical position it sweeps forward slightly. In moving to the left the motion is similar,—at the lowest point the staff inclines to the left front. A combination of right and left is made with a figure-of-eight motion.

In making "front" the flag is lowered and moved very slightly to the left front and then swept slightly to the right front, making a figure-of-eight.

The body should be twisted and bent at the waist in making the light and left motions.

Care should be exercised in keeping the flag in front of the body in making "front," the figure-of-eight is necessarily very flat.

Do not make letters in a careless slipshod manner.

The Two-arm Semaphore Code

(See [Plates I](#) and [II](#))

863. Semaphore signaling may be done with or without flags. Without flags it is rarely dependable beyond 600 yards.

In sending stand with feet apart, squarely facing the receiver.

In making letters which require the use of both arms on the same side of body, twist the body to that side and bend at waist, so as to throw both arms well away from body. But be careful to keep arms in plane of original position of body.

[Pg 219]

When a letter repeats—bring both hands (if a two-armed letter) to chest after first, then make second.

Do not try to send rapidly so as to exhibit your ability. Remember that the receiver's ability determines the speed to be used. Anyone can send faster than he himself can receive. If you want to display your skill have some one send rapidly to you.

In receiving, if you miss a letter—let it go and get the others. If you miss a word signal—"O" (waving flags or arms) and signal the last word you have received.

Rapidity is secondary to *accuracy*.

Take the positions for the various letters *accurately*. The horizontal position should not incline upward nor downward. In making an "L," for example, if the left arm is midway between its proper position and the horizontal it is difficult to tell whether it is L or M.

In making D, J, K, P, T, and V, the arm in the vertical position should be brought exactly in front of the body by carrying the shoulder in almost under the chin, twisting the elbow in until it is directly before the eyes, and the forearm held in the vertical position with the palm to the rear. When so done there is no possibility of this position being mistaken for any other.

"Manila Milkman" may be sent without changing the position of the right hand. In making I, be sure to twist body well to the right in order that the left arm may be seen in the upper slanting

position to the right. City and similar words may be so made.

D may be made with either hand.

Be sure how next letter is made before moving hands. Make no false motions.

Acquire accuracy; then try for speed.

"CHOP-CHOP." The "chop-chop" signal is made by placing *both* arms at the right horizontal (that is, by bringing the *left* arm up to the position of the *right* arm as in the figure for letter "B"), and then moving each up and down, several times, in opposite direction, making a cutting motion.

END OF WORD. After each word the "Interval" signal is made.

END OF SENTENCE. After each sentence the chop signal is made twice.

END OF MESSAGE. At the end of a message the chop signal is made three times.

ERROR. Signal "A" several times quickly, followed by interval; then repeat the word.

TO BREAK IN. Signal "Attention."

NUMERALS. Numbers are always preceded by the signal, "Numerals." After "Numerals" has been signaled, everything that follows will be numbers until "Interval" is signaled, after which what follows will be letters.

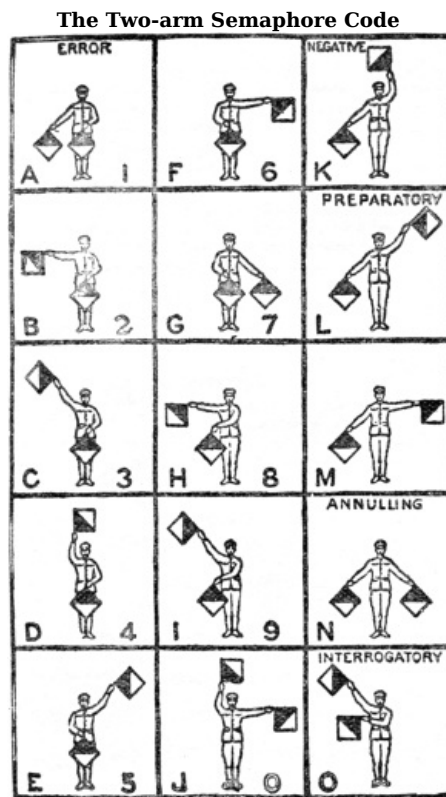

Plate I

The Two-arm Semaphore Code

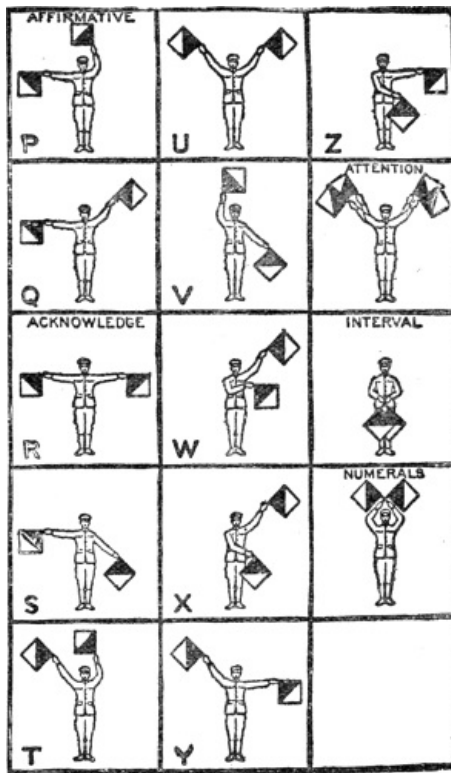

Plate II

Signaling with heliograph, flash lantern, and searchlight (with shutter)^[7]

- 864.** 1. The first position is to turn a steady flash on the receiving station. The signals are made by short and long flashes. Use a short flash for dot and a long steady flash for dash. The elements of a letter should be slightly longer than in sound signals.
2. To call a station, make the call letter until acknowledged, at intervals the call or signal of the calling station.
3. If the call letter of a station be unknown, signal a series of dots rapidly made until acknowledged. Each station will then turn on a steady flash and adjust. When the adjustment is satisfactory to the called station, it will cut off its flash, and the calling station will proceed with its message.
4. If the receiver sees that the sender's mirror needs adjustment, he will turn on a steady flash until answered by a steady flash. When the adjustment is satisfactory, the receiver will cut off his flash and the sender will resume his message.
5. To break the sending station for other purposes, turn on a steady flash.

Sound Signals^[7]

- 865.** 1. Sound signals made by the whistle, foghorn, bugle, trumpet, and drum may be used in a fog, mist, falling snow, or at night. They may be used with the dot and dash code.
2. In applying the code to whistle, foghorn, bugle, or trumpet, one short blast indicates a dot and one long blast a dash. With the drum, one tap indicates a dot and two taps in rapid succession a dash. Although these signals can be used with a dot and dash code, they should be so used in connection with a preconcerted or conventional code.

Morse Code. (American Morse Code)^[7]

866. Used only by the army on telegraph lines, on short cables, and on field lines, and on all commercial lines in the United States.

A	•	-		
B	-	•	•	•
C	•	•		•
D	-	•	•	
E	•			
F	•	-	•	

G	-	-	.		
H	
I	.	.			
J	-	.	-	.	
K	-	.	-		
L	—				
M	-	-			
N	-	.			
O	.		.		
P
Q	.	.	-	.	
R	.		.	.	
S	.	.	.		
T	-				
U	.	.	-		
V	.	.	.	-	
W	.	-	-		
X	.	-	.	.	
Y
Z
&

NUMERALS

1	.	-	-	.	
2	.	.	-	.	.
3	.	.	.	-	.
4	-
5	-	-	-		
6
7	-	-	.	.	
8	-
9	-	.	.	-	
0	—	—			

PUNCTUATION

Period	.	.	-	-	.	.
Comma	.	-	.	-		
Interrogation	-	.	.	-	.	

FOOTNOTES:

[6] Extracts from Signal Book, United States Army.

[7] Extracts from Signal Book, United States Army.

PART II

COMPANY COMMAND

CHAPTER I

867. The proper performance of the duty of COMPANY COMMANDER, like the proper performance of any other duty, requires work and attention to business.

The command of a company divides itself into two kinds of duty: government and administration.

The government includes the instruction, discipline, contentment, and harmony of the organization, involving, as it does, esprit de corps, rewards, privileges, and punishments.

The administration includes the providing of clothing, arms, ammunition, equipage, and subsistence; the keeping of records, including the rendition of reports and returns; and the care and accountability of Government and company property, and the disbursement of the company fund.

System and care are prerequisites of good administration.

The efficient administration of a company greatly facilitates its government.

THE CAPTAIN

868. With regard to his company the captain stands in the same light as a father to a large family of children. It is his duty to provide for their comfort, sustenance, and pleasure; enforce strict rules of obedience, punish the refractory and reward the deserving.

He should be considerate and just to his officers and men and should know every soldier personally and make him feel that he so knows him.

He should by word and act make every man in the company feel that the captain is his protector.

The captain should not be indifferent to the personal welfare of his men, and when solicited, being a man of greater experience, education, and information, he should aid and counsel them in such a way as to show he takes an interest in their joys and sorrows.

When any men are sick he should do everything possible for them until they can be taken care of by the surgeon. He can add much to the comfort and pleasure of men in the hospital by visiting them from time to time and otherwise showing an interest in their condition.

In fact, one of the officer's most important duties is to look after the welfare of his men—to see that they are well fed, well clothed and properly cared for in every other way—to see that they are happy and contented. The officer who does not look after the welfare of his men to the best of his ability, giving the matter his earnest personal attention, neglects one of the principal things that the Government pays him to do.

[Pg 225]

The soldier usually has a decided feeling for his captain, even though it be one of hatred. With regard to the higher grade of officers, he has respect for them according to regulations; otherwise, for the most part, he is indifferent. At the very most, he knows whether his post or regimental commander keeps him long at drill, and particularly whether he has any peculiar habits. The average soldier looks upon his captain as by far the most important personage in the command.

There is no other position in the Army that will give as much satisfaction in return for an honest, capable and conscientious discharge of duty, as that of captain. There is a reward in having done his full duty to his company that no disappointment of distinction, no failure, can deprive him of; his seniors may overlook him in giving credits, unfortunate circumstances may defeat his fondest hopes, and the crown of laurel may never rest upon his brow, but the reward that follows upon the faithful discharge of his duty to his company he can not be deprived of by any disaster, neglect or injustice.

He is a small sovereign, powerful and great, within his little domain.

869. Devolution of Work and Responsibility. The company commander should not attempt to do all the work—to look after all the details in person—he should not try to command directly every squad and every platoon. The successful company commander is the one who distributes work among his subordinates and organizes the help they are supposed to give him. By War Department orders, Army Regulations and customs of the service, the lieutenants and noncommissioned officers are charged with certain duties and responsibilities. Let every one of them carry the full load of their responsibility. The company commander should not usurp the functions of his subordinates—he should not relieve them of any of their prescribed or logical work and responsibility. On the contrary, he should give them more, and he should see that they "deliver the goods." Skill in distributing work among subordinates is one of the first essentials of leadership, as is the ability to get work out of them so that they will fill their functions to the full within the limits of their responsibility. Not only does devolution of work and responsibility cause subordinates to take more interest in their work (it makes them feel less like mere figure-heads), but it also teaches them initiative and gives them valuable experience in the art of training and handling men. Furthermore, it enables the company commander to devote more time to the

larger and more important matters connected with the discipline, welfare, training, instruction and administration of the company.

The captain who allows his lieutenants to do practically nothing makes a mistake—he is doing something that will rob his lieutenants of all initiative, cause them to lose interest in the company, and make them feel like nonentities—like a kind of "fifth wheel"—it will make them feel they are not, in reality, a part of the company—it will prevent them from getting a practical, working knowledge of the government and administration of a company.

By allowing his lieutenants to participate to the greatest extent possible in the government and administration of the company, and by not hampering and pestering them with unnecessary instructions about details, the captain will get out of his lieutenants the very best that there is in them.

[Pg 226]

The captain should require RESULTS from his lieutenants, and the mere fact that a lieutenant is considered inefficient and unable to do things properly, is no reason why he should not be required to do them. The captain is by Army Regulations responsible for the efficiency and instruction of his lieutenants regarding all matters pertaining to the company, and he should require them to perform all their duties properly, resorting to such disciplinary measures as may be considered necessary. The lieutenant who can not, or who will not, perform his duties properly is a drag on the company, and such a man has no business in the Army, or in the Organized Militia.

THE LIEUTENANT

870. To be able to perform well the duties of captain when the responsibility falls upon him, should be the constant study and ambition of the lieutenant.

He is the assistant of the captain and should be required by the captain to assist in the performance of all company duties, including the keeping of records and the preparation of the necessary reports, returns, estimates and requisitions. The captain should give him lots to do, and should throw him on his own responsibility just as much as possible. He should be required to drill the company, attend the daily inspection of the company quarters, instruct the noncommissioned officers, brief communications, enter letters in the Correspondence Book, make out ration returns, reports, muster and pay rolls, etc., until he shows perfect familiarity therewith.

Whenever told to do a thing by your captain, do it yourself or see personally that it is done. Do not turn it over to some noncommissioned officer and let it go at that. If your captain wants some noncommissioned officer to do the thing, he himself will tell him to do it—he will not ask you to do it.

It is customary in the Army to regard the company as the property of the captain. Should the lieutenant, therefore, be in temporary command of the company he should not make any changes, especially in the reduction or promotion of noncommissioned officers without first having consulted the captain's wishes in the matter.

It is somewhat difficult to explain definitely the authority a lieutenant exercises over the men in the company when the captain is present. In general terms, however, it may be stated the lieutenant can not make any changes around the barracks, inflict any punishment or put men on, or relieve them from, any duty without the consent of the captain. It is always better if there be a definite understanding between the captain and his lieutenants as to what he expects of them, how he wishes to have certain things done and to what extent he will sustain them.

If the lieutenant wants anything from the company in the way of working parties, the services of the company artificer or company clerk, the use of ordnance stores or quartermaster articles, he should always speak to the captain about the matter.

[Pg 227]

THE CAPTAIN AND THE LIEUTENANTS

871. The company officers should set an example to their men in dress, military bearing, system, punctuality and other soldierly qualities. It should be remembered that the negligence of superiors is the cue for juniors to be negligent.

If the men of a company are careless and indifferent about saluting and if they are shabby and lax in their dress, the company commander is to blame for it—company officers can always correct defects of this kind, if they will only try.

The character and efficiency of officers and the manner in which they perform their duties are reflected in the conduct and deportment of their men.

Of course, courage is a prerequisite quality for a good officer, and every officer should seek to impress his men that he would direct them to do nothing involving danger that he would not himself be willing to do under similar circumstances.

If a company officer be ignorant of his duties, his men will soon find it out, and when they do they will have neither respect for, nor confidence in, him.

Company officers should take an active interest in everything that affects the amusement, recreation, happiness and welfare of their men.

An officer just joining a company should learn without delay the names of all the men. A roll of the organization should be gotten and studied.

While an officer can gruffly order a soldier to do a thing and have his orders obeyed, it should be remembered that, as a rule, human nature, especially American human nature, responds best to an appeal to pride, fairness, justice, reason, and the other nobler instincts of man. It is only in rare instances that the average man will give the best there is in him under coercion or pressure of authority.

There are but few men who have not some good in them, and this good can generally be gotten at, if one only goes about it in the right way. Study your men and try to arouse in them pride and interest in their work.

The soldier first learns to respect, then to honor and finally to love the officer who is strict but just; firm but kind—and this is the officer who will draw out of his men the very best there is in them.

872. Treat your men like men, and remember there is nothing that will so completely take the spirit out of a man as to find fault with him when he is doing his best.

Young officers sometimes run to one of two extremes in the treatment of their men—they either, by undue familiarity, or otherwise, cultivate popularity with the men; or they do not treat them with sufficient consideration—the former course will forfeit their esteem; the latter, ensure their dislike, neither of which result is conducive to commanding their respect.

[Pg 228]

Treat your soldiers with proper consideration, dignity, and justice—remember they are members of your profession, the difference being one of education, rank, command, and pay—but they are men, like yourself, and should be treated as such.

Under no circumstances should you ever swear at a soldier—not only is this taking a mean, unfair advantage of your position, but it is also undignified, ungentlemanly, and unmilitary. It is even more improper for you to swear at a soldier than it is for a superior to swear at you—in the latter case the insult can be properly resented; in the former, it must be borne in humiliating silence.

Remember, that if by harsh or unfair treatment you destroy a man's self-respect, you at the same time destroy his usefulness.

Familiarity is, of course, most subversive of discipline, but you can treat your men with sympathetic consideration without being familiar with them.

In dealing with enlisted men, do not use the same standard of intellect and morals that apply in the case of officers. And remember, too, that a thing that may appear small and trivial to an officer may mean a great deal to an enlisted man—study your men, learn their desires, their habits, their way of thinking, and then in your dealings with them try to look at things from their standpoint also. In other words in your treatment of your men be just as human as possible.

The treatment of soldiers should be uniform and just, and under no circumstances should a man be humiliated unnecessarily or abused. Reproof and punishment must be administered with discretion and judgment, and without passion; for the officer who loses his temper and flies into a tantrum has failed to obtain his first triumph in discipline. He who can not control himself can not control others.

Every officer should study himself carefully, he should analyze himself, he should place himself under a microscopic glass, so as to discover his weak points—and he should then try with his whole might and soul to make these weak points strong points. If, for instance, you realize that you are weak in applied minor tactics, or that you have no "bump of locality," or that you have a poor memory, or that you have a weak will, do what you can to correct these defects in your make-up. Remember "Stonewall" Jackson's motto: "A man can do anything he makes up his mind to do."

The Progress Company, Chicago, Ill., publishes "Mind Power," "Memory," "The Will," "The Art of Logical Thinking" (all by W. W. Atkinson), and several other books of a similar nature, that are both interesting and instructive. "The Power of the Will," by Haddock, for sale by Albert Lewis Pelton, Meriden, Conn., is an excellent book of its kind.

THE FIRST SERGEANT

873. It has been said the captain is the proprietor of the company and the first sergeant is the foreman.

Under supervision of the captain, he has immediate charge of all routine matters pertaining to the company.

In some companies in the Regular Army, it is customary for soldiers, except in cases of emergency, to get permission from the first sergeant to speak to the company commander at any time. In other organizations soldiers who wish to speak to the company commander away from the company quarters must first obtain the first sergeant's permission, but it is not necessary to get this permission to speak to the company commander when he is at the barracks.

[Pg 229]

The first sergeant is sometimes authorized to place noncommissioned officers in arrest in quarters and privates in confinement in the guardhouse, assuming such action to be by order of the captain, to whom he at once reports the facts. However, with regard to the confinement of soldiers by noncommissioned officers, attention is invited to the Army Regulations on the subject.

THE NONCOMMISSIONED OFFICERS

(The status, duties, etc., of noncommissioned officers are covered in greater detail in Noncommissioned Officers' Manual, by the author. General agents: George Banta Publishing Co., Menasha, Wis.)

874. The efficiency and discipline of a company depend to such an extent on the noncommissioned officers that the greatest care and judgment should be exercised in their selection. They should be men possessing such soldierly qualities as a high sense of duty, cheerful obedience to orders, force of character, honesty, sobriety and steadiness, together with an intelligent knowledge of drills, regulations, and orders.

They should exact prompt obedience from those to whom they give orders, and should see that all soldiers under them perform their military duties properly. They must not hesitate to reprove them when necessary, but such reproof must not be any more severe than the occasion demands.

The company officers must sustain the noncommissioned officers in the exercise of their authority, except, of course, when such authority is improperly or unjustly exercised. If they do wrong, they should be punished the same as the privates, but if it be simply an error of judgment they should merely be admonished. A noncommissioned officer should never be admonished in the presence of privates.

Judicious praising of noncommissioned officers in the presence of privates is not only gratifying to the noncommissioned officer, but it also tends to enhance the respect and esteem of the privates for him.

In addition to dividing the company into squads, each squad being under a noncommissioned officer as required by the Army Regulations, the company should also be divided into sections, each section being in charge of a sergeant. The squads and sections should, as far as possible, be quartered together in barracks, and the chiefs of squads and the chiefs of sections should be held strictly responsible for the conduct, dress, cleanliness, and the care of arms of the members of their respective squads and sections. Not only does this throw the corporals and the sergeants upon their own responsibility to a certain extent, but it also impresses upon them the importance of their position, and gets the privates in the habit of realizing and appreciating the authority exercised by noncommissioned officers.

When practicable, the noncommissioned officers should have separate rooms or tents, and should mess together at tables separate from the privates; for, everything that conduces to familiarity with inferiors tends to lower the dignity of the noncommissioned officers' position.

[Pg 230]

Throw your noncommissioned officers upon their own responsibility—throw them into deep water, so to speak, where they will either have to swim or sink. You can never tell what a man can really do until you have given him a chance to show you—until you have put him on his mettle—until you have tried him out. And very often men who seem to have nothing in them, men who have never before been thrown upon their own responsibility, will surprise you.

Do all you can to make your noncommissioned officers realize and appreciate the importance of their position. Consult them about different matters—get their opinions about various things. When going through the barracks at Saturday morning inspection, for instance, as you come to the different squads, have the squad leaders step to the front and follow you while you are inspecting their respective squads. If you find anything wrong with a man's bunk, speak to the squad leader about it. Also ask the squad leaders various questions about their squads.

Not only does such treatment of noncommissioned officers make them appreciate the importance, responsibility and dignity of their position, but it also gives them more confidence in themselves and raises them in the eyes of the privates.

Noncommissioned officers should always be addressed by their titles, by both officers and soldiers.

Noncommissioned officers are forbidden by regulations to act as barbers, or as agents for laundries, or in any other position of a similar character.

Everything possible should be done by the company officers to instruct the noncommissioned officers properly in their duties.^[8]

So far as the company is concerned, the noncommissioned officers are expected to assist the company commander in carrying out his own orders and those of his superiors—they should see that all company orders are obeyed and that the known wishes of the captain are carried out. If, for instance, the captain should tell the first sergeant that the men in the company may play cards among themselves, but that noncommissioned officers are not to play with privates and that men from other companies are not allowed to take part in, or to be present at the games, then it is the duty of the first sergeant to see that these instructions are carried out—it is his duty to make frequent inspections of the tables at which the men may be playing to see that no noncommissioned officers are playing and that no outsiders are present. The first sergeant who confined himself to publishing the order to the company and then doing nothing more, would be neglectful of his proper duty.

Noncommissioned officers clothed in the proper uniform of their grade are on duty at all times and places for the suppression of disorderly conduct on the part of members of the company in public places. Men creating disorder will be sent to their quarters in arrest and the facts reported to the company commander without delay.

[Pg 231]

Noncommissioned officers can do much to prevent the commission of offenses by members of their commands, both when on and when off duty, and such prevention is as much their duty as reporting offenses after they are committed; in fact, it is much better to prevent the offense than to bring the offender to trial.

Company commanders should drill their noncommissioned officers thoroughly in the principles of discipline.

875. Noncommissioned Officers Authorized to Confine Enlisted Men. A company or detachment commander may delegate to his noncommissioned officers the authority to confine enlisted men in the guardhouse and to place them in arrest in quarters, provided the case is immediately reported to the company or detachment commander, who confirms the act of the noncommissioned officer and adopts it as his own.—W. D. decision, December, 1905.

876. Reduction and Resignation. A noncommissioned officer should never be reduced to ranks, except for grave and sufficient reasons. Nothing demoralizes the noncommissioned officers of a company so much and upsets discipline to such an extent as the feeling that upon the slightest pretext or fancy one is to be sent back to the ranks, to associate with the privates he has been required to discipline.

In some regiments noncommissioned officers are permitted to send in formal resignations, while in other regiments they are not, but, with the approval of the company commander, they may ask for reduction, giving proper, satisfactory and specific reasons. Of course, resignations submitted in a spirit of accepted insubordination or pique should not be considered, nor should they ever be in substitution for deserved disciplinary punishment. If a noncommissioned officer has good reasons for requesting reduction and the granting of the request would not result in detriment to the company, there is no reason why his application should not be favorably considered. However, in such a case, the noncommissioned officer should consult his company commander before submitting his request in writing. It is thought the preponderance of custom is against considering formal resignations.

Contentment and Harmony

877. The officers of the company should do everything possible to make the organization contented and harmonious. Contentment and harmony are not only conducive to good discipline and efficiency, but they also make the government of the company easy and reduce desertions to a minimum.

The showing of favoritism on the part of the captain is always a cause of great dissatisfaction amongst the soldiers in the company. Soldiers do not care how strict the captain is, just so he is fair and impartial, treating all men alike.

878. The Mess. The captain should give the mess his constant personal attention, making frequent visits to the kitchen and dining-room while the soldiers are at meals so as to see for himself what they are getting, how it is served, etc.

[Pg 232]

It is not saying too much to state that, in time of peace, a good mess is the real basis of the contentment of a company.

Ascertain what the soldiers like to eat and then gratify their appetites as far as practicable.

Be careful that the cook or the mess sergeant doesn't fall into a rut and satiate the soldiers day after day with the same dishes.

Give the ration your personal attention—know yourself what the company is entitled to, how

much it is actually getting, what the savings amount to, etc.

879. Library and Amusement Room. A library and an amusement room, supplied with good books, magazines, papers, a billiard or pool table, and a phonograph, are a source of much pleasure and contentment.

880. Athletic Apparatus. A judicious investment of the company fund in baseballs, bats, dumb bells, Indian clubs, boxing gloves and other athletic goods, and the encouragement of baseball, basketball, quoits, etc., are in the interest of harmony and happiness.

Rewards and Privileges

881. 1. Deny all passes and requests for privileges of men whose conduct is not good, and on the other hand grant to men whose conduct is good, as many indulgences as is consistent with discipline.

2. Judicious praise in the presence of the first sergeant, a few noncommissioned officers, or the entire company, depending upon circumstances, very often accomplishes a great deal. After the according of such praise, let your action toward the man show that his good conduct is appreciated and that it has raised him in your estimation, and make him feel you are keeping your eye on him to see whether he will continue in his well doing.

3. Publication of commendatory orders, desirable special duty details, etc.

4. Promotion, and extra duty details which carry extra pay.

5. Meritorious conduct of importance should be noted in the soldier's military record and also on his discharge.

6. At the weekly company inspection, each chief of squad picks out the neatest and cleanest man in his squad—the captain then inspects the men so selected, the neatest and cleanest one being excused from one or two tours of kitchen police, or some other disagreeable duty; or given a two days' pass.

NOTE: Some officers do not think that good conduct should be especially rewarded, but that if all soldiers be held strictly accountable for their actions by a system of strict discipline, good conduct attains its own reward in the immunities it enjoys.

882. Company punishment. It is neither necessary nor desirable to bring every dereliction of duty before a court-martial for trial. In fact, the invariable preferring of charges for minor^[9] offenses will, as a rule, injure rather than help the discipline of a command. The 104th Article of War states, "The commanding officer of any detachment, company, or higher command may, for minor offenses not denied by the accused, impose disciplinary punishments upon persons of his command without the intervention of a court-martial, unless the accused demands trial by court-martial." The disciplinary punishments authorized may include admonition, reprimand, withholding of privileges, extra fatigue, and restriction to certain specified limits, but shall not include forfeiture of pay or confinement under guard. (Par. 333, Manual for Courts-Martial.)

[Pg 233]

Some Efficacious Forms of Company Punishment

883. 1. Extra fatigue under the Company Supply Sergeant or the noncommissioned officer in charge of quarters, cleaning up around and in the company quarters, scrubbing pots, scouring tin pans, polishing stoves, cutting wood, policing the rears, cutting grass, pulling weeds, polishing the brass and nickel parts in the water closets and bath rooms, washing and greasing leather, cleaning guns, boiling greasy haversacks, and in camp, digging drains and working around slop holes.

If the work be done well the offender may be let off sooner—if the work be not done well, he may be tried for it.

2. Men may not be allowed to leave the immediate vicinity of the barracks for periods ranging from one to ten days, during which time they are subject to all kinds of disagreeable fatigue, and required to report to the N. C. O. in charge of quarters at stated hours.

3. Breaking rocks for a given number of days. For every man so punished, a private of the same company is detailed as a sentinel and for every four men a corporal is detailed in addition—the idea being to cause every man in each organization to take an interest in preventing his own comrades from violating rules and regulations.

4. When two soldiers get into a row that is not of a serious nature, a good plan is to set them at work scrubbing the barrack windows—one on the outside and one on the inside, making them clean the same pane at the same time. They are thus constantly looking in each other's faces and before the second window is cleaned they will probably be laughing at each other and part friends rather than nursing their wrath.

5. Confinement to barracks, reporting to the noncommissioned officer in charge of quarters once every hour, from reveille to, say, 9 P. M.

NOTE: Some company commanders follow, for moral effect, the practice of publishing to their companies all summary court convictions of soldiers belonging to the organization.

Withholding of Privileges

1. Withholding of passes and of credit at the post exchange.
2. Withholding of furloughs.

884. Control of Drunken and Obscene Men. In order to control drunken and obscene men, they have been bucked and gagged until sufficiently sober to regain self-control and quiet down. The use of a cold water hose in such cases has been known to accomplish good results. Great care and judgment, however, should be exercised and no more force used than is absolutely necessary.

It may also be said that persistently filthy men have been washed and scrubbed.

885. Saturday morning and other company inspections are intended to show the condition of the organization regarding its equipment, military appearance and general fitness for service, and the condition of the quarters as regards cleanliness, order, etc. Usually everyone except the guard, one cook, and others whose presence elsewhere can not be spared, are required to attend inspections, appearing in their best clothes, their arms and accouterments being shipshape and spick and span in every respect.

[Pg 234]

A man appearing at inspection with arms and equipments not in proper shape, especially if he be a recruit or if it be his first offense, may be turned out again several hours later, fully armed and equipped, for another inspection, instead of being tried by summary court.

Property Responsibility

886. Special attention should be given to the care and accountability of all company property.

1. All property (tents, axes, spades, chairs, hatchets, etc.) should be plainly marked with the letter of the company.
2. Keep a duplicate copy of every memorandum receipt given for property, and when such property is turned in or another officer's memorandum receipt is given covering the property, don't fail to get your original memorandum from the quartermaster.
3. See that the quartermaster gives you credit for all articles turned in, or property accounted for on statement of charges, proceedings of a surveying officer or otherwise.
4. Have a settlement with the quartermaster at the end of every quarter as required by Army Regulations, taking an inventory of all property held on memorandum receipt and submitting to the quartermaster a statement of charges and a certified list of the china and glassware unavoidably broken during the quarter.
5. Keep an account of all articles issued to the men, turned in to the quartermaster, condemned, expended, lost, stolen or destroyed.
6. Worn out and unserviceable, property that is beyond repair in the company should be submitted to the action of a surveying officer, the Survey Reports (Form No. 196, A. G. O.) being prepared in triplicate, and submitted to the commanding officer, who will appoint a surveying officer. No property that can be repaired in the company should ever be submitted to the action of a surveying officer or inspector. In this connection company commanders and supply sergeants should be thoroughly familiar with Ordnance Department pamphlet No. 1965 and G. O. 26, 1917, the two covering the care, repair and disposition of unserviceable Ordnance equipment.
7. Property that is to be submitted to the action of a surveying officer or an inspector should always first be carefully examined by the responsible officer in person, who should be prepared to give all necessary information in regard to it.

The property should be arranged in the order of enumeration in the survey or the inventory report, and should be arranged in rows of five, ten, or some other number, so that the numbers of the various articles can be counted at a glance.

The Army Regulations require that the responsible officer shall be present at the inspection of property by a regular inspector. He should also be present when property is acted on by a surveying officer.

8. All company property (Ordnance, Quartermaster, Signal and Engineer) except the litter

[Pg 235]

COMPANY OFFICER'S REPORT.					MEDICAL OFFICER'S REPORT.		
DATE	SURNAME.	CHRISTIAN NAME.	RANK.	WHEN TAKEN SICK.	IN LINE OF DUTY. (Yes or No.)	IN LINE OF DUTY. (Yes or No.)	DISPOSITION.
Aug 30	Smith, Paul		Pvt.	8-14-16	No	No	Hosp.
	Edwards, Samuel		Pvt.	8-19-16	Yes	Yes	Hosp.
	Edwards Moore, Capt.		37 th	Inf. Comd. Co.			Harrison, Maj. M. C.
Aug 21	Smith, Paul		Pvt.	8-14-16	No	No	Hosp.
	Edwards, Samuel		Pvt.	8-19-16	Yes	Yes	Qrs.
	Edwards Moore, Capt.		37 th	Inf. Comd. Co.			Harrison, Maj. M. C.
Aug 22	Smith, Paul		Pvt.	8-14-16	No	No	Hosp.
	Edwards, Samuel		Pvt.	8-19-16	Yes	Yes	Duty
	Smart, Edward		Corp.	5-22-16	Yes	Yes	Duty
	Edward Moore, Capt.		37 th	Inf. Comd. Co.			Harrison, Maj. M. C.

Fig. 3 (click to enlarge)

890. Duty Roster. On which is kept a record of all details for guard duty, kitchen police, and other details for service in garrison and in the field, except the authorized special and extra duty details. For instructions regarding the keeping of roster, see, "Details and Rosters," Manual of Interior Guard Duty and the Model and instructions on the form itself.

[Pg 237]

891. Files of Orders. A file will be kept of all orders issued by the company commander. Files will also be kept of all orders and instructions received from higher authority.

892. Company Fund Book. In which are entered all receipts to, and expenditures from, the company fund, together with the monthly proceeding of the Company Council of Administration, and a list of property, with cost thereof, purchased from the company fund. The model in the front of the book shows how the account is to be kept.

893. Correspondence Book, with index. In which is entered a brief of each item of correspondence in respect to which a record is necessary, and a notation of the action taken thereon.

894. Document File, being the original documents or communications when these are retained, and carbon, letter press, or other copies of letters, indorsements, or telegrams sent in regard to the same, all of which are filed according to serial numbers.

895. Delinquency Record, in which are noted the disciplinary punishments awarded by the company commander in compliance with the provisions of Army Regulations.

896. Property Responsibility. Two loose-leaf books in which are listed, in one all articles of quartermaster property, and in the other, all articles of ordnance property, issued each soldier for his personal use.

897. Service Record. (Formerly known as "Descriptive List.") One for each member of the company, in which is kept a full description of him, including date of enlistment, personnel description, record of deposits, trial by court-martial, record of vaccination, clothing account, etc.

898. Descriptive Card of Public Animals. To be kept in organizations supplied with public animals.

899. Retained Copies of Rolls, Returns, etc. Retained copies of the various rolls, reports, and returns (property and other) that are required by orders and regulations.

900. Memorandum Receipts, showing all articles of ordnance quartermaster, and other property that may be held on memorandum receipt, with date of receipt, from whom received, etc. The company commander has a quarterly settlement with the staff officers concerned.

901. Abstract Record of Memorandum Receipts. For keeping a record of property issued on memorandum receipt, in connection with the unit accountability equipment.

902. Record of Rifles, showing the number of the rifle, the Arsenal where made, date of receipt, to whom issued, and number of shots fired each target season. (Note. Geo. Banta Publishing Co., Menasha, Wis., print an excellent card for this purpose.)

903. Summary Court Records. Commanding officers are required to furnish organization commanders with true copies of all summary court records relating to men of their organizations, which papers form a part of the records of the organization.

904. Statement of Clothing Charged to Enlisted Men. When clothing is drawn individually from the quartermaster, the Individual Clothing Slips are entered on the Statement of Clothing Charged to Enlisted Men, which is filed with the requisition to which it pertains.

[Pg 238]

905. Abstract of Clothing. All individual clothing slips are entered on this abstract as the issues are made, the total quantities and money values being determined and the abstract completed at the end of month or when the organization leaves the vicinity of the issuing quartermaster for an extended period. At the close of period covered, the organization commander compares his copy of the abstract with the quartermaster's copy, and it is then filed with the Individual Clothing Slips and Statement of Clothing Charged to Enlisted men.

(b) Deduct from the above the number of men absent according to the morning report of Feb. 29/16, and for whom rations will not, therefore, be drawn for any part or for the whole of the month of March, the number of men absent being (assumed) as follows:

On furlough	3	
On detached service	2	
Absent sick	2	
Absent in confinement	1	
Present sick in hospital	4	
Attached to and rationed with the band	2	14
Balance		83

(c) Add the number of men attached to the company for rations, which (it is assumed) consists of two general prisoners

		2
		85

TOTAL

That is to say, we have 85 men for whom one ration per day must be drawn for the month of March, that is to say, 31 days.

Hence, the total number of rations will be, $85 \times 31 = 2635$ rations.

(d) Additions and deductions must be made as follows:

Additions

For the men who were attached to the company for rations and who joined during the month of February, from absent sick, furlough, detached service, etc., and which (let us assume) the "Plus" column of "Rations" on the company morning report for February shows to be

150

Deductions

For the men who left the company during the month of February, on account of being sent to the hospital sick, going on furlough, etc., and which (let us assume) the "Minus" column of "Rations" on the company morning report for February shows to be

200

Leaving us (a "Net correction") to be *added* of

50

And making the total number due the company for the month of March

2585

EXTRA ISSUES

The Army Regulations fixes the maximum allowance of soap, toilet paper, matches, etc., the commanding officer being authorized, if he so desires, to determine the allowances, with the prescribed maximum. The allowances are based either on so much per ration, per so many rations, or per organization. In the case of candles and matches the allowance is left entirely to the commanding officer.

"Model" Ration Return

Attached: General Prisoners Hart and Young. No. _____
Q. M. C. Form No. 22R. Authorized April 27, 1913. (QUARTERMASTER'S NUMBER)

Ration Return of Co. "H", 50th Infantry,
 At Fort Porter, N. Y., from March 1, 1916, to March 31, 1916.
 No. of days 31, persons present 83 plus 2 attached, No. of rations 2635
 Additions 150, deductions 200, net corrections 50

NUMBER RATIONS REQUIRED	GARRISON.	FIELD.	RESERVE.	TRAVEL.	FILIPINO.	TOTAL
	2585	-----	-----	-----	-----	2585

No. emergency rations required _____

Other issues required, quantities actually required within regulation allowance: (No. of animals _____)

SOAP.	CANDLES, ISSUE.	CANDLES, LANTERN.	MATCHES.	TOILET PAPER.	SALT, ROCK.	VINEGAR FOR ANIMALS.	FLOUR FOR PASTE.	TOWELS, FLUX.	ICE.
LBS.	LBS.	LBS.	BOXES	PKGS.	LBS.	GALES.	LBS.	NO.	LBS.
103	-----	-----	24	43	-----	-----	-----	-----	-----

Fig. 6 (click to enlarge)

Example

(See "model" ration return above)

Soap. Allowance is 0.64 for each ration or 4 lbs. to 100 rations. $25.85 \times 4 = 103.40$, i. e., the company is entitled to 103 lbs. of soap for the month of March.

Toilet paper. Allowance is 1000 sheets for every 60 rations, $2585 \div 60 = 43+$, that is, the company is entitled to 43 packages of toilet paper.

Matches. Allowance of matches for lighting fires and lights, for which fuel and the illumination supplies are issued, is such as the commanding officer may order as necessary.

Flour. Allowance of flour for paste used in target practice is 50 lbs. for each troop or company for the practice season.

FOOTNOTES:

[8] Silicate Roll Blackboards, which are perfectly flexible and can be rolled tightly, like a map, without injury, may be obtained from the New York Silicate Book Slate Co., 20 Vesey St., New York. They are made in various sizes, about the most convenient for use

in noncommissioned officers' schools is No. 3, three by four feet—price \$2.

- [9] For example, noisy or disorderly conduct in quarters, failure to salute officers, slovenly dressed at formations, rifle equipments not properly cleaned at inspection or other formations, overstaying pass, short absences without leave and absences from formations (especially for first offense).

CHAPTER II

[Pg 243]

DISCIPLINE

910. Definition. Discipline is not merely preservation of order, faithful performance of duty, and prevention of offenses—in other words, discipline is not merely compliance with a set of rules and regulations drawn up for the purpose of preserving order in an organization. This is only one phase of discipline. In its deeper and more important sense discipline may be defined as the habit of instantaneous and instinctive obedience under any and all circumstances—it is the habit whereby the very muscles of the soldier instinctively obey the word of command, so that under whatever circumstances of danger or death the soldier may hear that word of command, even though his mind be too confused to work, his muscles will obey. It is toward this ultimate object that all rules of discipline tend. In war, the value of this habit of instantaneous and instinctive obedience is invaluable, and during the time of peace everything possible should be done to ingrain into the very blood of the soldier this spirit, this habit, of instantaneous, instinctive obedience to the word of command.

911. Methods of Attaining Good Discipline. Experience shows that drill, routine, military courtesy, attention to details, proper rewards for good conduct, and invariable admonition or punishment of all derelictions of duty, are the best methods of attaining good discipline—that they are the most effective means to that end.

912. Importance. History shows that the chief factor of success in war is discipline, and that without discipline no body of troops can hold their own against a well-directed, well-disciplined force.

913. Sound System. We must bear in mind that what may be considered a sound system of discipline at one epoch or for one nation, may be inapplicable at another epoch or for another nation. In other words, sound discipline depends upon the existing state of civilization and education, the political institutions of the country, the national trait and the national military system. For example, the system of discipline that existed in the days of Frederick the Great, and which, in modified form, exists today in certain European armies, whereby the soldier was so inured to a habit of subjection that he became a sort of machine—a kind of automaton. Such a system of discipline, while answering admirably well its purpose at that time and for those nations, would not do at all in this day and generation, and with a people like ours, in whom the spirit of personal freedom and individual initiative are born. Of course, the discipline that will insure obedience under any and all conditions—the discipline that will insure prompt and unhesitating obedience to march, to attack, to charge—is just as important today as it was a thousand years ago, but we can not attain it by the machine-making methods of former times. The system we use must be in keeping with the national characteristics of our people and the tactical necessities of the day, the latter requiring individual initiative. According to the old system, the company commander imposed his will upon a body of submissive units; under the new system the company commander, backed by authority and greater knowledge, leads obedient, willing units, exacting ready obedience and loyal coöperation. The company commander used to drive; now he leads.

[Pg 244]

914. Means of attaining and maintaining such discipline.

1. Explain to the men the importance of discipline and its value on the field of battle, and give the reasons that makes it necessary to subject soldiers to restrictions that they were not subjected to in civil life.
2. Do not impose unnecessary restrictions or hardships on your men, nor issue orders that have no bearing on their efficiency, health, cleanliness, orderliness, etc.
3. Demand a high standard of excellence in the performance of all duties whatsoever, and exact the utmost display of energy.

A system of discipline based on the above principles develops habits of self-control, self-reliance, neatness, order, and punctuality, and creates respect for authority and confidence in superiors.

915. Punishment. In maintaining discipline, it must be remembered the object of punishment should be two-fold: (a) To prevent the commission of offenses, and (b) to reform the offender. Punishment should, therefore, in degree and character depend upon the nature of the offense. Punishment should not be debasing or illegal, and the penalty should be proportionate to the nature of the offense. If too great, it tends to arouse sympathy, and foster friends for the

offender, thus encouraging a repetition of the offense. A distinction, therefore, should be made between the deliberate disregard of orders and regulations, and offenses which are the result of ignorance or thoughtlessness. In the latter case the punishment should be for the purpose of instruction and should not go to the extent of inflicting unnecessary humiliation and discouragement upon the offender.

General Principles

916. In the administration of discipline the following principles should be observed.

1. Everyone, officers and soldiers, should be required and made to perform their full duty. If the post commander, for instance, requires the company commanders to do their full duty, they will require their noncommissioned officers to do their full duty, and the noncommissioned officers will in turn require the men to do the same.
2. Subordinates should be held strictly responsible for the proper government and administration of their respective commands, and all changes or corrections should be made through them.
3. Subordinates should have exclusive control of their respective commands, and all orders, instructions and directions affecting their commands should be given through them.
4. If, in case of emergency, it be not practicable to make certain changes or corrections, or to give certain orders, instructions or directions, through the subordinates, they should be notified at once of what has been done.
5. After a subordinate has been placed in charge of a certain duty, all instructions pertaining thereto should be given through him, and all meddling and interfering should be avoided. Interference by superiors relieves the subordinate of responsibility, and causes him to lose interest, become indifferent, and do no more than he is obliged to do. [Pg 245]
6. The certainty of reward for, and appreciation of, meritorious conduct, should equal the certainty of punishment for dereliction of duty.
7. It is the duty of an officer or noncommissioned officer who gives an order to see that it is obeyed; carrying out orders received by him does not end with their perfunctory transmission to subordinates—this is only a small part of his duty. He must personally see that the orders so transmitted are made effective.
8. The treatment of soldiers should be uniform and just, and under no circumstances should a man be humiliated unnecessarily or abused. Reproof and punishment must be administered with discretion and judgment, and without passion; for an officer or noncommissioned officer who loses his temper and flies into a tantrum has failed to obtain his first triumph in discipline. He who can not control himself can not control others.
9. Punishment should invariably follow dereliction of duty, for the frequency of offenses depends, as a general rule, on the degree of certainty with which their commission is attended with punishment. When men know that their derelictions and neglects will be observed and reproved, they will be much more careful than they would be otherwise—that's human nature.

A strict adherence to the above general principles will instill into the minds of those concerned, respect for authority and a spirit of obedience.

PART III

[Pg 246]

MISCELLANEOUS SUBJECTS PERTAINING TO COMPANY TRAINING AND INSTRUCTION

CHAPTER I

[Pg 247]

GENERAL PRINCIPLES OF COMPANY TRAINING AND INSTRUCTION^[10]

917. Object of Training and Instruction. The object of training and instructing a company is to thoroughly knit together its different parts, its various elements (individuals, squads and platoons), into a complete, homogeneous mass, a cohesive unit, that will under any and all conditions and circumstances respond to the will of the captain—a cohesive unit that knows how to march, that knows how to live properly in camp, that knows how to fight and that can be readily handled tactically on the field of battle. In short, the object of training and instruction is to make out of the company an efficient, wieldy fighting weapon, to be manipulated by the captain. There is but one way this object can be obtained, and that is by work, work, work—and then more work—by constant care, attention and pains—by coöperation, by team work, among

the officers, the noncommissioned officers and the privates.

918. Method and Progression. Arrangement is an essential of sound teaching. Training and instruction in order to be easily understood and readily assimilated—in order to give the greatest results in the shortest time—must be carried on according to a methodical and progressive plan. Each subject or subjects upon a knowledge of which depend the proper understanding and mastering of another, should be studied and mastered before taking up the other subject, and the elementary and simpler aspects of a given subject must be mastered before taking up the higher and more difficult phases of the subject, which means that individual training and instruction must precede, and provide a sound foundation for, collective training and instruction—that is to say, for the higher tactical training and instruction of the company as a unit. These basic, fundamental principles of successful training and instruction apply to practical as well as theoretical training. For instance, in the subject of entrenchments we would first instruct the men individually in the use of the tools and in the construction and use of the trenches, after which we would pass on to the tactical use of entrenchments by the company. Also, in training and instructing the company in fire discipline, we would first explain to the men the power and tactical value of the rifle, and instruct them in their duties on the firing line as regards adjustment of sights, attention to commands, economy of ammunition, etc.; we would explain to the platoon commanders and guides their duties as regards control of fire, enforcement of fire discipline, etc., after which we would practice the company as a unit in fire action, and fire control, ending up with an exercise showing the tactical application of the rules and principles explained. And again, in the training and instruction of the company in the attack, we would first train and instruct the company in all the formations and operations that naturally precede an attack (patrolling, outposts, advance guard, rear guard), and also in those that form an inherent part of an attack (extended order, field firing, use of cover, etc.).

[Pg 248]

919. Program. The training and instruction of a company, whether practical or theoretical, should be carried on in accordance with a fixed, definite program, in which the subjects are arranged in a natural, progressive order.

920. Simultaneous Instruction and Training. The next question that presents itself is: Should instruction and training in each branch be completed before proceeding to the next, or should instruction and training be carried on simultaneously in two or more different subjects, as one, for example, are taught mathematics, French and history at the same time, a different hour of the day being devoted to each subject? In other words, should we, for instance, devote one hour of the day to attack, one hour to defense, and one hour to the service of security, thus preventing the soldier from getting weary of doing the same thing that whole day? Our answer is:

1st. If the instruction and training is being given on the ground where the application of the principles of any given subject is varied so much by the type of the ground and the nature of the situation, each type of ground affording a different solution of the problem, it is thought the best results can be obtained by finishing each subject before proceeding to the next, thus not losing the "atmosphere" of one subject by switching to the next, and also confusing the minds of the men with different principles.

2nd. However, if the instruction and training be theoretical and the time available each day be several hours, better results can be obtained by studying two or more subjects simultaneously. This would also be the case if the work be practical, but if it be such that the type of the ground and the nature of the situation will not of themselves afford variety in the application of the same principles.

921. Responsibility. The Army Regulations and War Department orders hold the company commander responsible for the training and instruction of the company. The subject is a most important one and should receive serious thought and study. Before admonishing one of your men for not knowing a subject, always ask yourself, "Have I made an effort to teach it to him?"

922. Interest. Special effort should be made to make the training and instruction of the company interesting, so that the work will not become monotonous and irksome, and thus cause the men to lose interest and get stale. To accomplish this, these points should be borne in mind:

Variety. Inject variety into the work. Do not keep the men too long at one thing.

Clearness. Every exercise, lesson or lecture should have in view a well-defined object, the meaning and importance of which must be explained to, and understood by, the men at the beginning of the exercise, lesson or lecture. In other words, at the beginning, explain the main, governing idea of the subject, and then take pains to explain in a simple, conversational way each phase as you come to it. Give the reasons for everything. You can not expect men to take an interest in things the meaning of which they do not understand and the reason for which they do not see. Make sure by asking questions of different ones as you go along that your explanations are understood.

[Pg 249]

Thoroughness. Every lecture, talk, drill or exercise should be carefully planned and arranged beforehand. Remember, that the men who are going to listen to your talk—the men who are going to go through the exercise—have the right to expect this of you, and you have no right to compel them to listen to lots of disconnected, half-baked statements, or make them go through a disjointed exercise or drill. In the case of tactical exercises always, if practicable, visit and

examine the terrain beforehand. Of course, all this will mean work—additional work—but remember the government pays you to work.

Reality. Make all practical work as real as possible—do not permit the commission of absurdities—do not let men do things which manifestly they would not be able to do in actual practice—and you yourself be sure to make your exercises and tactical scheme as like real conditions of warfare as possible.

923. Individual Initiative. The effective range and great power of modern firearms cause troops in battle to be spread out over large areas, thus decentralizing control over men and operations, and consequently increasing the value and importance of individual initiative. The company commander should, therefore, practice, accustom and encourage the privates, noncommissioned officers and lieutenants in the development and exercise of individual initiative and responsibility. This should be borne in mind in all training and instruction.

Officers, noncommissioned officers and privates must not "lay down" just because they have no specific orders. Remember, the one thing above all others that counts in war, is **action, initiative**. Indeed, 'tis better to have acted and lost than never to have acted at all. Listen to what the Chief of Staff of the Army has to say about this in the preface to the Field Service Regulations: "Officers and men of all ranks and grades are given a certain independence in the execution of the tasks to which they are assigned and are expected to show initiative in meeting the different situations as they arise. Every individual, from the highest commander to the lowest private, must always remember that inaction and neglect of opportunities will warrant more severe censure than an error in the choice of means."

924. Determination and Individual Intelligence. While the value of discipline can hardly be overestimated, there are two other factors in battle that are fully as important, if not more so, and they are, **determination** to win, and **individual intelligence**, which, in war, as in all other human undertakings, almost invariably spell success. Therefore, make these two factors one of the basic principles of the instruction and training of the company, and do all you can to instill into your men a spirit of determination, and to develop in them individual intelligence. Every human being has in his soul a certain amount of determination, even though it be only enough to determine upon the small things of life. Some people are born with more determination than others, but it is a mistake to suppose that a man must remain through life with the same amount of determination that he brought into it. The attributes of the human mind, such as determination, bravery, ambition, energy, etc., are all capable of improvement and also of deterioration. It is essential therefore, for us to endeavor by all means in our power to improve our strength of character—our determination. It is, of course, useless for us to learn the art of war if we have not sufficient determination, when we meet the enemy, to apply the principles we have studied. There is no reason, however, why every officer, noncommissioned officer and private should not improve his determination of character by careful training in peace. It can only be done by facing the difficulties, thoroughly understanding the dangers, and asking ourselves repeatedly whether we are prepared to face the ordeal in war. Let us not think, in a vague sort of a way, that in war we shall be all right and do as well as most people. We know that we are not gifted with tremendous personal courage, and we know that, whatever happens, we shall not run away. But that is not enough. We must train ourselves to understand that in the hour of trial we can harden our hearts, that we can assume the initiative, and retain it by constant advance and constant attack; unless we can fill our hearts with the determination to win, we can not hope to do our full duty on the field of battle and acquit ourselves with credit.

[Pg 250]

925. The Human Element. No system of training and instruction that does not take into account human nature, can be thoroughly effective. The human element probably enters into war more than it does into any other pursuit. The old idea of turning a human being into a machine, by means of discipline, and making him dread his captain more than the enemy, died long ago, especially with the American people. In modern war success depends to a great extent upon the initiative, the individual action of the soldier and this action is greatly influenced by the soldier's state of mind at the moment, by the power that can be exercised over his mind by his comrades and those leading him. The company commander should, therefore, study the characteristics of the human mind with the object of ascertaining how he can influence the men under his command, so that in battle those human attributes which are favorable to success, may be strengthened and those which are favorable to defeat may be weakened. Of the former, courage, determination, initiative, respect, cheerfulness, comradeship, emulation and esprit de corps, are the principal ones; of the latter, fear, surprise, disrespect, and dejection, are the leading ones. By means of good, sound discipline, we can create, improve and foster the qualities mentioned that are favorable to success, and we can eliminate to a considerable extent, if not entirely, those that are detrimental to success.

926. Fear. The emotion of fear acts more powerfully upon the feelings of the individual soldier than any other emotion, and it is also probably the most infectious. Fear in a mild form is present in every human being. Nature wisely put it there, and society could not very well get along without it. For example, we stop and look up and down a crowded street before starting to cross, for fear of being run over; in going out in the cold we put on our overcoats, for fear of catching cold. In fact, we hardly do anything in life without taking a precaution of some kind. These are all examples of reasonable fear, which, within bounds is a perfectly legitimate attribute of a soldier in common with other human beings. For example, we teach the men to take advantage of cover

[Pg 251]

when attacking, and we dig trenches when on the defense, in both cases for fear of being shot by the enemy. It is the unreasoning type of fear that plays havoc in war, and the most deadly and common form of it is a vague, indefinite, nameless dread of the enemy. If the average man was to analyze his feelings in war and was to ask himself if he were actually afraid of being killed, he would probably find that he was not. The ordinary soldier is prepared to take his chance, with a comfortable feeling inside him, that, although no doubt a number of people will be killed and wounded, he will escape. If, then, a man is not unreasonably afraid of being killed or wounded, is it not possible by proper training and instruction to overcome this vague fear of the enemy? Experience shows that it is. If a soldier is suffering from this vague fear of the enemy, it will at least be a consolation to him to know that a great many other soldiers, including those belonging to the enemy, are suffering in a similar manner, and that they are simply experiencing one of the ordinary characteristics of the human mind. If the soldier in battle will only realize that the enemy is just as much afraid of him as he is of the enemy, reason is likely to assert itself and to a great extent overcome the unpleasant feelings inside him. General Grant, in his Memoirs, relates a story to the effect that in one of his early campaigns he was seized with an unreasonable fear of his enemy, and was very much worried as to what the enemy was doing, when, all at once, it dawned upon him that his enemy was probably worrying equally as much about what he, Grant, was doing, and was probably as afraid as he was, if not even more so, and the realization of this promptly dispelled all of his, Grant's, fear. Confidence in one's ability to fight well will also do much to neutralize fear, and if a soldier knows that he can shoot better, march better, and attack better, than his opponent, the confidence of success that he will, as a result, feel will do much to dispel physical fear. By sound and careful training and instruction make your men efficient and this efficiency will give them confidence in themselves, confidence in their rifles, confidence in their bayonets, confidence in their comrades and confidence in their officers.

The physical methods of overcoming fear in battle are simply to direct the men's minds to other thoughts by giving them something for their bodies and limbs to do. It is a well-known saying that a man in battle frequently regains his lost courage by repeatedly firing off his rifle, which simply means that his thoughts are diverted by physical movements. This is no doubt one of the reasons why the attack is so much more successful in war than the defense, because in the attack the men are generally moving forward and having their minds diverted by physical motion from this vague dread of the enemy.

927. Courage. Courage, like all other human characteristics, is very infectious, and a brave leader who has no fear of the enemy will always get more out of his men than one who is not so well equipped in that respect. However, it is a well-known fact that a man may be brave far above his fellows in one calling or occupation, and extremely nervous in another. For example, a man may have greatly distinguished himself in the capture of a fort, who would not get on a horse for fear of being kicked off. Courage of this kind is induced chiefly by habit or experience—the man knows the dangers and how to overcome them, he has been through similar experiences before and he has come out of them with a whole skin. This type of courage can be developed by careful training during peace, and it can be increased by self-confidence—by so training the soldier that he knows and feels he will know what to do in any emergency which may arise, and how to do it; he will not be surprised by the unexpected event, which invariably occurs, and he will understand others besides himself are being troubled by unpleasant feelings, which it is his duty as a man and a soldier to overcome.

[Pg 252]

928. Surprise. Surprise may be said to be the mother of a panic, which is the worst form of fear. In such a case unreasoning fear sometimes turns into temporary insanity. Panic is most infectious, but, on the other hand, a panic can often be averted or stayed by the courageous action of one or more individuals, who can thus impose their will on the mass and bring the people to a reasonable state of mind. **Teach every man in the company that when surprised the only hope of success is to obey at once and implicitly the orders of his immediate commander.**

Surprises in war are not limited to the ordinary acceptance of the term, such as a sudden attack from an unexpected direction. The soldier who goes into battle, for instance, and hears the whiz of a bullet, or sees a shell burst in front of him, is surprised if he has not been taught in peace that these things have to be faced, and that for one bullet that hurts anyone thousands have to be fired. Similarly, a man sees a comrade knocked over; the horrors of war are immediately brought to him, and his courage begins to ebb—he has been surprised, because he has not realized in peace that men are bound to be killed in war. The whole atmosphere of the battlefield is a surprise to the average soldier with no previous experience—the enemy is everywhere, behind every bush, and lurking in every bit of cover, the air is full of bullets, and any advance towards the formidable-looking position held by the enemy is suicidal. However, if the soldier is properly trained and instructed in peace, he will not be greatly surprised at his novel surroundings; he will know that the enemy is not everywhere, and that one bullet sounds much more dangerous than it really is. A bullet sounds quite close when it is fifty yards away, and there is a popular saying that a man's weight in lead is fired for every man that is killed in war.

929. Respect. It is a mistake to imagine that all that is required from a soldier is respect to his officers and noncommissioned officers. Self-respect is fully as important. A soldier is a human being; if he possesses self-respect he will respect all that is good in his comrades, and they will respect all that is good in him. A man who respects himself knows how to respect other people. These are the men that form the backbone of the company, and are the best material on which to

work in order to raise the general standard of courage in Battle. From a purely military point of view, it is absolutely necessary for an officer, noncommissioned officer, or private to possess some marked military qualifications in order to gain respect from others.

[Pg 253]

This respect engenders confidence in others. Self-respect in the individual can be encouraged, not by fulsome praise, but by a quiet appreciation of the good military qualities displayed by him, and by making use of those qualities whenever an opportunity occurs. For example, if a soldier is seen to do a good piece of scouting or patrolling, the first opportunity should be taken to give him a similar task, if possible in a more responsible position or on a more important occasion. Knowledge is a powerful factor in creating respect, and is probably second only to determination of character. It is essential, therefore, that all officers and noncommissioned officers should have a thorough knowledge of their duties—that they should be "on to their jobs."

930. Cheerfulness. Cheerfulness is a valuable military asset in war, and like all other characteristics of the human being, is very infectious, and in times of depression, such as during a long siege, or after the failure of an attack, it does more than anything else to restore the fighting power of the men.

931. Contentment. Contentment amongst troops in war is dependent upon these main factors: good leading, good food, and sufficient shelter and sleep. Of these, good leading is by far the most important, because it has been proved time and again that badly fed and badly quartered troops, who have suffered great hardships, will still be content and will fight in the most gallant and vigorous manner, provided they are well led. Although good leading emanates in the first instance from the highest military authorities, a great deal depends upon the company officers and noncommissioned officers. A good leader as a rule is careful of the comforts of his men; he obtains the best food and best shelter available, he does not wear out the men by unnecessary movements or unnecessary work, either in the field or in camp, and consequently when he does order them to do anything they know at once that it is necessary and they do it cheerfully.

932. Comradeship. Comradeship is a very valuable military characteristic. What a world of meaning there is in the words, "Me and my bunkie." A soldier may have many acquaintances and a number of friends, but he has but one "bunkie." In times of great danger two men who are "bunkies" will not shirk so easily as two independent men. The best in one man comes out to the surface and dominates any bad military points in the other. They can help each other in countless ways in war, and if one is unfortunately killed or wounded, the other will probably do his best to get even with the enemy at the earliest possible opportunity. This spirit may not be very Christianlike, but it is very human and practical, and helps to win battles, and to win battles is the only reason why soldiers go to war.

ART OF INSTRUCTION ON THE GROUND

933. Advantages. Whenever practicable, training and instruction should, in whole or in part, be imparted on the ground, as this gives the instruction a practical aspect that is most valuable, and enables the soldier to grasp and apply principles that he would not otherwise understand. Knowledge that a man can not apply has no value.

[Pg 254]

934. Different Methods. Instruction on the ground may be given according to one of these three methods:

1st Method. By means of a talk or lecture prepare the minds of the men for the reception and retention of the subject to be explained later on the ground. In other words, first explain the principles of the subject and then put a "clincher" on the information thus imparted by taking the men to some suitable ground, assuming certain situations and then by quizzing different men see how they would apply the principles just explained in the talk or lecture. For example, after a lecture on the selection of fire-positions take the men to some suitable nearby place and explain to them that the company is attacking toward that house and is being fired upon from that direction. Then continue:

Captain: Remember what I told you about the selection of good fire-positions during the advance. We want to use our rifles with effect, so we must be able to see the position of the enemy. On the other hand, we want to avoid being hit ourselves, if possible; so, we would like to get as much cover as possible. Now, Smith, do you think where we are at present standing is a good place for a fire-position?

Smith: No, sir.

Captain: Why not?

Smith: We can see the enemy from here, but he can see us better than we can see him, and can hit us easier than we can hit him.

Captain: Jones, can you choose a better place, either to the front or rear of where we are now standing?

Jones: I would choose a position along that row of bushes, about fifty yards to the front.

Captain: Why?

Jones: Because, etc., etc.

Twenty minutes' instruction in this manner, after a lecture, will firmly fix in the brains of the men the principles explained in the lecture.

It is a good plan to repeat the salient points of the lecture in the questions, as was done in the first question asked above, or to do so in some other way.

If a man can not give an answer, or choose a suitable place, explain the requirements again and help him to use his common sense.

2d Method. By practicing the men on the ground in the subject about which the talk or lecture was delivered.

3d Method. This may be called the ocular demonstration method, which consists in having a part of the company go through the exercise or drill, while the rest of the company observes what is being done. This method is illustrated by the following example:

935. Attack. The company commander has just delivered a talk to the company on the second stage of the attack, and has marched the company to a piece of ground suitable for practicing this particular operation, and which the company commander has himself visited beforehand (The ground should always be visited beforehand by the company commander, who should be thoroughly familiar with it. If possible, ground suitable for practicing the operation in question should always be selected.) The operation should begin about 1200 yards from the enemy's position. After pointing out the enemy's position to the company, the particular part of his line it is intended to assault and the direction the company is to advance, the company commander would then proceed something like this: "We are part of a battalion taking part in a battle, and there are companies to our right and left, with a support and reserve in our rear. So far we have been advancing over ground that is exposed to hostile artillery fire (or not exposed to hostile artillery fire, according to the actual country). We have just come under the enemy's infantry fire also, and consequently we must change our method of advancing. Our immediate object is to get forward, without expending more ammunition than is absolutely necessary, to a position close enough to the enemy to enable us to use our rifles with such deadly effect that we will be able to gain a superiority of fire. Now, is this place sufficiently close for the purpose? No, it is not—it's entirely too far away. Is that next ridge just in front of us close enough? No, it is not; it is at least 1,000 yards from the enemy's position. As a rule, we must get from eight to six hundred yards from the enemy's position before the real struggle for superiority of fire begins.

[Pg 255]

"The following are the main points to which attention must be paid during this part of the advance:

"1. We must halt in good fire position from which we can see and fire at the enemy, and from which we can not be seen very clearly.

"2. We must advance very rapidly over any open ground that is exposed to the enemy's artillery or rifle fire.

"3. We must find halting places, if possible under cover, or under the best cover available, so as to avoid making our forward rushes so long that the men will get worn out, and begin to straggle long before they get close enough to the enemy to use their rifles with deadly effect.

"4. Whenever possible, company scouts should be sent on ahead to select fire-positions."

Of course, the above points will have been explained already in the lecture, but this short summary is given in order to focus the minds of the men upon the action that must be taken by the privates, and squad leaders and the platoon commanders.

We now take one platoon and the remainder of the company looks on. The platoon commander is reminded that he is under artillery and infantry fire, and is then directed to advance, in proper formation, to the first fire-position available.

We will suppose there is a gentle slope up to the next ridge or undulation of the ground, and that there are no obstructions to the view except those afforded by the ground itself. The platoon now advances, the captain remaining with the rest of the company, pointing out mistakes as well as good points, and asking the men questions, such as:

Captain: Corporal Smith, should the whole platoon have gone forward together, or would it have been better to advance by squads?

Corporal Smith: I think it should have advanced by squads.

Captain: No, it was all right to advance as they did. At this distance the enemy's infantry fire would not be very deadly, the platoon is well extended as skirmishers, it would take considerably longer to go forward to the next position by successive squads and we want to advance at this stage as rapidly as possible; for, the longer we took, the longer would the men be exposed to fire,

[Pg 256]

and consequently the greater would be the number of casualties.

Captain: Sergeant Jones, why did the platoon advance at a run when moving down the slope, and begin to walk just before reaching the foot of the slope?

Sergeant Jones: Because the slope is exposed and it was necessary to get over it as quickly as possible. They began to walk just before reaching the foot of the slope, because they struck dead ground and were covered from the enemy's fire by the ridge in front.

Captain: Corporal Adams, shouldn't the platoon have halted when it reached cover, so as to give the men a rest?

Corporal Adams: No, sir; the men had not run very far and walking gave them sufficient rest. It would have been an unnecessary loss of time to halt.

Captain: Harris, why did that man run on ahead as soon as the platoon halted?

Pvt. Harris: So he could creep up the crest of the ridge and lie down in exactly the spot that is the best fire-position—that is, where he can just see to fire over the crest and where the enemy can not see him.

Captain: Yes, that's right. All the men in the platoon might not stop at the best fire-position and in the hurry and excitement of the moment the platoon commander might also fail to do so, but if a man goes forward and lies down, the whole platoon knows that they must not go beyond him. Individual men who, owing to slight undulations of ground, may not be able to fire when they halt in line with this man, can creep up until they can see. Others who, for the same reason as regards the ground, find that if they get up on a line with the man they will be unduly exposed, will halt before that time.

Captain: Sergeant Roberts, is it necessary for another platoon to provide covering fire during the advance of the platoon?

Sergeant Roberts: No sir. At this range the enemy's infantry fire would not be very effective, and it is important to husband our ammunition for the later stages of the attack.

Having asked any other questions suggested by the situation or the ground, the captain will then take the rest of the company forward over the ground covered by the platoon, halting at the place where the platoon changed its pace from a rush to a walk, so that the men can see for themselves that cover from fire has been reached. He will then move the rest of the company forward and tell them to halt and lie down in what each man considers to be the best fire-position, not necessarily adopting the same position as that chosen by the leading platoon. The platoon commanders will then go along their platoons and point out any mistakes.

The leading platoon will now join the company and another platoon will be deployed in the fire position, the platoon commander being directed to advance to the next fire-position.

As we are now about 1,000 yards from the enemy's position the question will again arise as to whether covering fire is necessary.

If the enemy's rifle fire were heavy and accurate it might be necessary, but it should be avoided if possible, on account of the expenditure of ammunition.

[Pg 257]

We will suppose that the ground falls gently towards the enemy and is very exposed to view for about 300 yards, and half this distance away there is a low bank running parallel to the front of the attack and with a small clump of three or four trees on the bank directly in front of the platoon. Four hundred yards away is the bottom of the valley covered with bushes and shrubs. On the far side the ground rises with small undulations and low foot hills to the high ground occupied by the enemy.

There appears to be no marked fire-position which will afford any cover except the bank 150 yards away. The second platoon advances in the same manner as did the first and the captain with the commanders of the remaining platoons will continue to ask questions and point out what has been done right or wrong by the leading platoon. The first question which will arise is whether the platoon can reach the fire position offered by the bank in one rush, and secondly, whether the bank is a good fire-position. A former question will again crop up as to whether the whole platoon should go forward at once or whether the advance should be made by squads.

A hundred and fifty yards is a long way to advance without a halt, and if a halt is made on such exposed ground fire must be opened. Probably three advances, each of about fifty yards, would be made, covering fire being provided by the other platoons, which will be occupying the fire-position which the leading platoon has just left. This covering fire would not endanger the leading platoon as it would be delivered from just behind the crest and the leading platoon would be over the crest and out of sight and therefore out of fire from the platoon in rear.

The selection of a fire-position during this advance would depend upon very minute folds of the ground, or very low bushes, grass, etc., which might give a certain amount of cover from view, and therefore make it difficult for the enemy to aim or range accurately. We will suppose that the

leading platoon has halted to fire about fifty yards in front, the remaining platoons, in turn, should then be taken forward, examining the ground very carefully as they go, and each platoon commander asked to halt his platoon in what he considers to be the best place.

The possibility of using a scout to select a fire-position would be considered, and a fire-position selected by one platoon would be compared with that selected by another.

The third platoon would then lead during the advance to the next fire-position, and so on with the fourth platoon, if necessary, until the bank was reached. The bank will afford a good deal of material for discussion. Is it a good fire-position or is it not, should it be occupied as such or should it be avoided altogether?

If we ask an artillery officer his opinion about the matter, he will tell us that by means of the clump of trees the defenders' artillery will be able to range with absolute accuracy on that bank. The direction of the bank is parallel to their front, and therefore they can fire at any part of it for some distance right and left of the clump without materially altering their range, and if any infantry occupy the bank they can bring a very deadly fire to bear against them.

[Pg 258]

There appears to be no doubt, from an artillery point of view, that our platoon should avoid occupying it and get out of its neighborhood as rapidly as possible.

There is another drawback as regards the bank: it is some 850 yards from the enemy's position and may be expected to be under an effective rifle fire. It is no doubt a good mark for the enemy, and, now we come to the crux of the whole matter; his artillery and infantry fire might not do us much damage so long as we remain behind the bank, but they might make it very unpleasant for us directly we try to leave this cover and advance further.

Before finally deciding what to do we must consider human nature, which is entirely in favor of halting behind the bank, and if allowed to remain there long, will be opposed to leaving it. We cannot hope to gain superiority of fire over the enemy at a range of 850 yards, so that a long halt at the bank is out of the question. But it appears to be an extraordinary thing, when we are searching everywhere for cover, that we should be doubtful about occupying such good cover when we find it.

If we decide not to occupy it, the logical conclusion is that, when preparing a position for defense, we should construct a good fire-position for the attack some 850 yards away, which is the last thing we should think of doing.

There is no doubt about it, that with badly-trained troops such a fire-position would be liable to become a snare, and that if they once occupied it, there would be great difficulty in getting them forward again, and probably the attack would be brought to a standstill at a critical time.

The answer appears to be found in the simple solution of good training. We must teach our men that when they get into such positions they must use the cover afforded, but for no longer than any other fire-position, and that they must get into the habit in peace of looking upon such localities with suspicion, and with the knowledge that they are not suitable for lengthy occupation in war, if the battle is to be won.

We now come to a still more difficult question of training, namely, how far can the company get forward from the bank without being compelled to stop in order to gain superiority of fire over the defense? In war we want to get as close as possible; the moral effect on the defense is greater, our fire is more effective, and we are likely to gain our object more rapidly. In peace there is no fire to stop us, and we move forward to ridiculous positions which we could not possibly reach in war without first gaining superiority of fire. The result of this is that we try to do the same thing when first we go to war, and we are stopped, probably much further back than we should have been if we had studied the question in peace.

Even on the most open ground we must get to within 600 yards of the enemy, and if the ground affords any cover in front, the exposed space must be rushed and the more forward position gained. Having pointed out this difficulty to the company during the previous lecture, and reminded them of it on the ground, we can now extend the whole company and move forward from the bank, using covering fire and letting each platoon commander decide how far he can get to the front after a series of rushes, the company acting as a whole.

[Pg 259]

The captain can then go down the line and discuss with each platoon the position it has reached. Whilst he is doing this, the remaining platoons can be trained in fire direction and control, which should be carefully watched and criticized by the platoon commanders. One platoon, owing to the nature of the ground in front of it, can get forward further than other platoons, and this should be brought home to each platoon, so as to avoid the possibility of playing the game of follow your leader, and one platoon halting merely because another has halted.

If there is still time available, and the ground is suitable, the company can be moved to a flank to choose a similar fire-position where the ground is more favorable to an advance, and where the company could get within 300 yards of the enemy, or even less, before it would be absolutely necessary to stop in order to gain superiority of fire.

If there is still time available, and the ground is suitable, the whole operation can be carried out

in the opposite direction or in some other direction, and the platoons can thus be trained to appreciate that fire-positions which are good in one place are bad in another.

936. Defense. Demonstrations in defense can be carried out in a similar manner, the captain explaining to the company the general line of defense to be taken up, the portion allotted to the company, and the probable direction of the enemy's attack.

The coöperation of the artillery and infantry will have been pointed out in the previous lecture: how some part of the enemy's advance will be dealt with by artillery alone, some part by both artillery and infantry, and some part by infantry alone.

This can now be pointed out to the men on the ground. Having considered the assistance provided by the artillery, the next point to decide upon is the exact position of the fire trench. The best way to proceed is to allot a certain portion of the front occupied by the company to each platoon and to let the platoon commanders take charge of the operations. The platoon commander can direct one of his squads to select a position for the trench, and that squad can lie down there. The remaining squads will then select a position in turn. If two squads select the same they can lie down together. The platoon commander will then fall in his platoon, and make them lie down in the most retired position chosen; he will ask the squad leader why the squad chose that locality in preference to any other, why they did not go ten yards further forward or ten yards further back; and he will explain to the whole platoon the advantages and disadvantages of selecting this locality. He will then move the whole platoon forward to the next position chosen by another squad and deal with that locality. Finally, he will select the position he thinks the best, giving his reasons why he has decided upon it, and place the whole platoon on it. When all the platoons have decided upon their line of defense, the captain will move the whole company in turn from the ground occupied by one platoon to that occupied by another, asking the platoon commander in each case to explain why the position was chosen in preference to any other.

He will give his decision as regards each platoon, and he will finally arrange for the position to be occupied by the whole company. One platoon, for some good reason, may have chosen a place which it would not be safe to occupy, owing to the fire of another platoon on the flank. Another platoon may have chosen a place which was very good as regards the field of fire in a direction which was already adequately defended by another platoon, but which had a bad field of fire over ground which no other platoon could fire upon. The company commander would adjust all these matters, and in the end one or more platoons might not be placed in the best position as regards their own particular front, but in the best as regards the whole company.

[Pg 260]

Having decided upon the exact site of the trenches and the general distribution of fire, the next matter to consider is the amount of clearing that is necessary, and the position and nature of any obstacles which may be required. Each platoon commander having been allotted a definite fire zone, can point out to his platoon what clearance is necessary; he can then ask each squad, as before, to choose the position for the obstacle. The company commander can then take the whole company to the position occupied by each platoon and tell the platoon commander to explain what ground they propose to clear, where they propose to place their obstacle, the material available for its construction, and in every case the reason why the decision has been arrived at. If digging is permitted, the trenches will now be constructed, and care will be taken that they are actually finished. It is far better to work overtime than to construct trenches which would be of little use in war and could not be properly defended. It is the exception rather than the rule to see trenches properly finished, fit for occupation, and capable of resisting a heavy attack. If the trenches cannot be dug the company can be taken to another part of the same position, where the ground in front is totally different, and the exercise can be repeated, the platoon and company commanders pointing out why a fire trench which was well sited in the first case would be badly sited if a similar position was selected in the second case.

937. Outpost. We can now turn to the method of training the company in outpost duty, making use of the same system of demonstration. Having pointed out to the company the locality where the main body is bivouacked, the fighting position which the main body will occupy in case a heavy attack is made against the outposts, and the general line of the outposts, the company commander will indicate on the ground the extent of front which is to be guarded by his company, stating whether imaginary companies continue the position on one or both flanks. He will point out the possible avenues of approach from the direction of the enemy to that portion of the position to be occupied by the company, and state from which direction the enemy is most likely to advance and why.

The first point to decide is the number of outguards and their exact position. In war this would always be done by the company commander, but if it is desired to give the junior officers of the company some instruction in this important detail, they should be sent out before the company arrives on the ground to reconnoiter the position and make their decisions. The exact siting of the trenches for the outguards, the construction of obstacles, and the clearance of the foreground having been decided upon and the positions selected for each outguard discussed, and a definite site selected, the next question to decide is the number and position of the sentries.

[Pg 261]

The platoon commander would then take each scheme in turn, visit with the whole platoon each position selected for the sentry, and decide finally what it would be best to do, giving, as usual, his reasons.

Having decided upon the positions of the sentries, and their line of retreat, so as not to mask the fire of the outguard, the next matter to consider would be the number of patrols that are required, and the particular areas of ground that must be examined by them periodically. The necessary trenches, obstacles, etc., would then be constructed.

Finally, the whole company should be assembled, marched to the position chosen for each outguard and the reasons for selecting the position explained by the company commander. The company should then be told off as an outpost company, and divided into outguards, supports, if any, and the necessary sentries over arms, patrols, etc., and marched to their respective posts.

If there is still time available each platoon commander can reconnoiter the ground for suitable positions for his outguards by night, take the outguards there, explain why the change of position is desirable, and direct the outguard commanders with their outguards to select positions for the sentries, following the same procedure as by day.

Although it is quite correct to select positions for night outposts during daylight, when possible, they should never be definitely occupied by the company before dark, when the forward movement could not be observed by the enemy. To practice night outposts by day is bad instruction, outguards and sentries are placed in positions which appear ridiculous to the ordinary mind, and the men get confused ideas on the subject. When it is desired to practice day and night outposts as an advanced exercise it is advisable to commence work in the afternoon, establish the day outposts, reconnoiter for the night outposts, make the change after dark and construct the necessary trenches, obstacles, etc., after dark.

It is, however, extremely important that the patrols should get to know their way about the country in front during the daylight, when possible, so that they will have some practice in recognizing land marks by night.

It frequently occurs, when training the company in outpost duties, that periods elapse during which the outguards are doing nothing. These opportunities should be taken to instruct the men in their duties when ordered to patrol to the front, the same system of demonstration being employed. For instance, the officer or noncommissioned officer commanding a picket can select three men, point out certain ground in front which the sentries cannot see and which must be examined by a patrol, and proceed to instruct the whole picket in the best manner of carrying out this work. We will suppose that the patrol is working by day and that the ground to be visited is behind a small hill some 500 yards in front of the sentry. The commander of the picket will then explain to the men that the first object of the patrol is to reach the ground to be examined without being seen by any hostile patrols which may be moving about in front. Before proceeding further it is necessary for the patrol to decide upon the best line of advance. The various lines of advance will be discussed and the patrol asked to decide which they would select. Three other men can then be asked to give their opinion, and so on until all the men of the picket have expressed their views. The commander of the picket will then state which he considers the best line and give his reasons.

[Pg 262]

The next matter to decide is the method of advance to be adopted by the patrol. Are the three men to march past the sentry in one body and walk straight over the hill in front? If they do this there may be a hostile patrol hiding just behind the crest, watching the movements of our patrol, and directly the latter reach the hill they will be covered by the rifles of the hostile patrol at a few yards' range and will be captured or shot.

If the patrol is not to advance in one body how is it to act? There is plenty of time available, so that there are no objections to deliberate methods. The patrol should advance from cover to cover with one man always going forward protected by the rifles of the remaining two men who have halted in a good position to fire on any enemy that can fire on the leading man. The leading man having readied the cover in front will signal back all clear, and the two men in the rear will join him. They will then make their next advance in a similar manner.

By looking at the hill the patrol can make a good guess at the locality which a hostile patrol would select if it was on the hill. It would be a place where it could get a good view towards our outpost line, and where the patrol could not be seen itself from the outpost line. If the hill was quite bare with nothing but grass on it and flat round top, the best place for the enemy's patrol would be exactly on the top just behind the crest. In such a position he could not be seen by any sentry to the right or left of our picket. For example, if the hostile patrol chose a place on the side of the bare slope of the hill and looked over the crest line it would not be seen by our sentry, but it might be seen by another one on the flank.

The object of our patrol would be to approach the hill, not direct from the outguard, but either from the left or right of the hill and thus come on the flank of the enemy's patrol if he was there.

The whole picket can then be taken out to the front and follow the movements of the patrol from cover to cover until the hill is reached.

The next step will be to ascertain if there is any one on the top of the hill. If the hill is perfectly bare with a somewhat convex slope, it would be best for the three men to extend to about twenty yards interval and move forward together, prepared to drop on the first sign of the enemy, so that they can creep up and open fire on him without exposing themselves. Three men with

magazine rifles extended in this manner, opposed to a hostile patrol collected in one party, should be able to deal with the latter without much difficulty. Their fire would be converging, and coming from different directions would confuse the hostile patrol, especially if the advance was made from a flank. The men of the patrol when creeping up the hill should avoid exposing themselves in the direction of the ground behind the hill, if possible, because they want to examine that ground later on, and if seen by the enemy they might fall into an ambushade. If it is impossible to avoid being seen from the ground beyond, it would be best for the patrol to retire as though they were going back to the outposts, and then move round the flank of the hill and advance to the ground beyond from an unexpected direction. All this would be considered by the officer or noncommissioned officer commanding the picket, together with many other points.

[Pg 263]

Sufficient has been said to explain how this system of demonstration can be worked in connection with any class of operation in the field. It is certainly slow, and takes a long time, but no one is ever idle and every one is constantly learning something fresh, for the simple reason that, although one may know every detail of the subject, the ground constantly differs and requires to be dealt with in a common sense and skillful manner. The men are interested throughout, and one morning spent on this kind of work is worth several days of practice in the ordinary manner.

It should be remembered that this system of demonstration is only required to teach the men their work; when they have once learned it and thoroughly understand the necessary details they must be practiced in it, the company or platoon commander indicating what has been well done, what has been badly done, and what requires improvement. (See "Outposts," [Par. 1051](#).)

OTHER EXAMPLES OF THE OCULAR DEMONSTRATION METHOD

938. The following illustrations will suggest other examples of the employment of the ocular demonstration method of instruction:

The advantages and disadvantages of close and extended order. Send a lieutenant or a noncommissioned officer with two or three squads of the older soldiers some distance to the front of the company, and have them advance toward the company, first in close order and then in extended order.

By **ocular demonstration** show the men who are watching the approach of the company how easy it would be even for the poorest shots to land bullets in the thick of a closed body, but how much of a less distinct target the extended order offers and how many spaces there are in the skirmish line for the bullets to pass through; also, how much more easily cover can be employed and the rifle used in the extended order. Let them see also how much more difficult it is for the officers and noncommissioned officers to maintain control over the movements of troops in extended order, and the consequent necessity and duty of every soldier, when in extended order, doing all he can, by attention and exertion, to keep order and help his officers and noncommissioned officers to gain success.

939. The Use of Cover. Send a lieutenant or noncommissioned officer with a couple of squads of old soldiers a few hundred yards to the front and have them advance on the company as if attacking, first without taking advantage of cover and then taking advantage of all available cover, the part of the company that is supposed to be attacked lying down and aiming and snapping at the approaching soldiers. Then reverse the operation—send the defenders out and have them advance on the former attackers. Explain that the requisites of good cover are: Ability to see the enemy; concealment of your own body; ability to use the rifle readily. Then have a number of men take cover and snap at an enemy in position, represented by a few old soldiers. Point out the defects and the good points in each case.

[Pg 264]

940. Practice in Commanding Mixed Squads. In order to practice noncommissioned officers in commanding mixed firing squads, and in order to drill the privates in banding themselves together and obeying the orders of anyone who may assume command, it is good training for two or more companies to practice reënforcing each other by one company assuming a given fire-position and the other sending up reënforcements by squads, the men being instructed to take positions anywhere on the firing line where they may find an opening. However, explain to the men that whenever possible units should take their positions on the firing line as a whole, but that in practice it is very often impossible to do this, and that the drill is being given so as to practice the noncommissioned officers in commanding mixed units on the firing line and also to give the privates practice in banding themselves into groups and obeying the command of any noncommissioned officer who may be over them.

941. Operating Against Other Troops. There is no better way of arousing interest, enthusiasm, and pride in training troops than by creating a feeling of friendly rivalry and competition amongst the men, and the best way to do this is to have one part of the company operate against the other in all such practical work as scouting, patrolling, attacking, etc. Whenever practicable, blank ammunition should be used. One of the sides should wear a white handkerchief around the hat or some other distinguishing mark. **The troops that are sent out must be given full and explicit instructions as to just exactly what they are to do, so that the principles it is intended to illustrate may be properly brought out.**

FOOTNOTES:

- [10] This chapter is based on "Company Training," by General Haking, British Army, which is the best book the author has ever seen on the subject of company training. "Field Training of a Company of Infantry," by Major Craufurd, British Army, an excellent little book, was also consulted.

CHAPTER II

[Pg 265]

GENERAL COMMON SENSE PRINCIPLES OF APPLIED MINOR TACTICS^[11]

942. To begin with, you want to bear in mind that there is nothing difficult, complicated or mysterious about applied minor tactics—it is just simply the application of plain, every-day, common horse sense—the whole thing consists in familiarizing yourself with certain general principles based on common sense and then applying them with common sense. Whatever you do, don't make the mistake of following blindly rules that you have read in books.

943. One of the ablest officers in the Army has recently given this definition of the Art of War:

One-fifth is learned from books;
One-fifth is common sense;
Three-fifths is knowing men and how to lead them.

The man who would be successful in business must understand men and apply certain general business principles with common sense; the man who would be a successful hunter must understand game and apply certain general hunting principles with common sense, and even the man who would be a successful fisherman must understand fish and apply certain general fishing principles with common sense. And so likewise the man who would lead other men successfully in battle must understand men and apply certain general tactical principles with common sense.

Of course, the only reason for the existence of an army is the possibility of war some day, and everything the soldier does—his drills, parades, target practice, guard duty, schools of instruction, etc.—has in view only one end: The preparation of the soldier for the field of battle.

944. While the responsibilities of officers and noncommissioned officers in time of peace are important, in time of battle they are much more so: for then their mistakes are paid for in human blood.

What would you think of a pilot who was not capable of piloting a boat trying to pilot a boat loaded with passengers; or, of an engineer who was not capable of running a locomotive trying to run a passenger train? You would, of course, think him a criminal—but do you think he would be more criminal than the noncommissioned officer who is not capable of leading a squad in battle but who tries to do so, thereby sacrificing the lives of those under him?

You can, therefore, appreciate the importance, the necessity, of every officer and noncommissioned officer doing everything that he possibly can during times of peace to qualify himself for his duties and responsibilities during times of war.

[Pg 266]

If we are going to have a good army we must have good regiments; to have good regiments we must have good battalions; to have good battalions we must have good companies—but to have good companies we must have efficient company officers and noncommissioned officers.

As stated before, everything in the life of the soldier leads to the field of battle. And so it is that in the subject of minor tactics all instruction leads to the battle. First we have map problems; then terrain exercises; next the war game; after that maneuvers, and finally the battle.

945. Map Problems and Terrain Exercises. In the case of map problems you are given tactical problems to solve on a map; in the case of terrain exercises you are given problems to solve on the ground. (The word "Terrain," means earth, ground.) These are the simplest forms of tactical problems, as you have only one phase of the action, your information is always reliable and your imaginary soldiers always do just exactly what you want them to do.

946. War Game. Next comes the war game, which consists of problems solved on maps, but you have an opponent who commands the enemy—the phases follow one another rapidly and the conditions change—your information is not so complete and reliable. However, your men being slips of cardboard or beads, they will, as in the case of your imaginary soldiers in the map problems and terrain exercises, go where you wish them to and do what you tell them to do—they can't misunderstand your instructions and go wrong—they don't straggle and get careless as real soldiers sometimes do.

Map problems, terrain exercises and war games are but aids to maneuvers—their practice makes the maneuvers better; for you thus learn the principles of tactics and in the simplest and quickest

way.

947. Maneuvers. In the case of the maneuver the problem is the same as in the war game, except that you are dealing with real, live men whom you can not control perfectly, and there is, therefore, much greater chance for mistakes.

948. The battle. A battle is only a maneuver to which is added great physical danger and excitement.

General rules and principles that must be applied in map problems, terrain exercises, the war game and maneuvers

949. Everything that is done must conform in principle to what should be done in battle—otherwise your work is wasted—your time is thrown away.

In solving map problems and in the war game, always form in your mind a picture of the ground where the action is supposed to be taking place—imagine that you see the enemy, the various hills, streams, roads, etc., that he is firing at you, etc.—and don't do anything that you would not be able to do if you were really on the ground and really in a fight.

[Pg 267]

Whether it be a corporal in command of a squad or a general in command of an army, in the solution of a tactical problem, whether it be a map problem, a terrain exercise, a war game, maneuver or battle, he will have to go through the same operation:

- 1st. Estimate the situation;
- 2d. Decide what he will do;
- 3d. Give the necessary orders to carry out his decision.

At first these three steps of the operation may appear difficult and laborious, but after a little practice the mind, which always works with rapidity in accustomed channels, performs them with astonishing quickness.

The child beginning the study of arithmetic, for example, is very slow in determining the sum of 7 and 8, but later the answer is announced almost at sight. The same is true in tactical problems—the process may be slow at first, but with a little practice it becomes quick and easy.

950. Estimating the Situation. This is simply "sizing up the situation," finding out what you're "up against," and is always the first thing to be done. It is most important, and in doing it the first step is to determine your MISSION—what you are to do, what you are to accomplish—the most important consideration in any military situation.

Consider next your own forces and that of the enemy—that is, his probable strength and how it compares with yours.

Consider the enemy's probable MISSION^[12] and what he will probably do to accomplish it.

Consider the geography of the country so far as it affects the problem—the valleys to cross, defiles to pass through, shortest road to follow, etc.

Now, consider the different courses open to you with the advantages and disadvantages of each.

You must, of course, in every case know what you're up against before you can decide intelligently what you're going to do.

In making your plan always bear in mind not only your own MISSION, but also the general mission of the command of which you form a part, and this is what nine men out of ten forget to do.

951. The Decision. It is important that you should come to a clear and correct decision—that you do so promptly and then execute it vigorously.

The new Japanese Field Service Regulations tell us that there are two things above all that should be avoided—inaction and hesitation. "To act resolutely even in an erroneous manner is better than to remain inactive and irresolute"—that is to say do something.

You are now ready to come to a decision, which is nothing more or less than a clear, concise determination of what you're going to do and how you're going to do it. Frederick the Great, expressed the same idea in fewer words: "Don't haggle."

[Pg 268]

Having settled on a plan, push it through—don't vacillate, don't waver. Make your plan simple. No other has much show. Complicated plans look well on paper, but in war they seldom work out. They require several people to do the right thing at the right time and this under conditions of excitement, danger and confusion, and, as a result, they generally fail.

952. The Order. Having completed your estimate of the situation and formed your plan, you are now ready to give the orders necessary to carry it out.

You must first give your subordinates sufficient information of the situation and your plan, so that they may clearly understand their mission.

The better everyone understands the whole situation the better he can play his part. Unexpected things are always happening in war—a subordinate can act intelligently only if he knows and understands what his superior wants to do.

Always make your instructions definite and positive—vague instructions are sometimes worse than none.

Your order, your instructions, must be clear, concise and definite—everyone should know just exactly what he is to do.

A Few General Principles

953. The man who hunts deer, moose, tigers and lions, is hunting big game, but the soldier operating in the enemy's territory is hunting bigger game—he's hunting for human beings—but you want to remember that the other fellow is out hunting for you, too; he's out "gunning" for you. So, don't fail to be on the alert, on the lookout, all the time, if you do he'll "get the drop" on you. Remember what Frederick the Great said: "It is pardonable to be defeated, but never to be taken by surprise."

Do not separate your force too much; if you do, you weaken yourself—you take the chance of being "defeated in detail"—that is, of one part being defeated after another. Remember the old saying: "In union there is strength." Undue extension of your line (a mistake, by the way, very often made) is only a form of separation and is equally as bad.

While too much importance can not be attached to the proper use of cover, you must not forget that sometimes there are other considerations that outweigh the advantages of cover. Good sense alone can determine. A certain direction of attack, for instance, may afford excellent cover but it may be so situated as to mean ruin if defeated, as where it puts an impassable obstacle directly in your rear. And don't forget that you should always think in advance of what you would do in case of defeat.

What is it, after all, that gives victory, whether it be armies or only squads engaged? It's just simply inflicting on the enemy a loss which he will not stand before he can do the same to you. Now, what is this loss that he will not stand? What is the loss that will cause him to break? Well, it varies; it is subject to many conditions—different bodies of troops, like different timbers, have different breaking points. However, whatever it may be in any particular case it would soon come if we could shoot on the battlefield as we do on the target range, but we can not approximate it.

[Pg 269]

There are many causes tending to drag down our score on the battlefield, one of the most potent being the effect of the enemy's fire. It is cited as a physiological fact that fear and great excitement cause the pupil of the eye to dilate and impair accuracy in vision and hence of shooting. It is well established that the effectiveness of the fire of one side reduced proportionately to the effectiveness of that of the other.

Bear in mind then these two points—we must get the enemy's breaking point before he gets ours, and the more effective we make our fire the less effective will be his.

Expressed in another way—to win you must gain and keep a fire superiority.

This generally means more rifles in action, yet a fire badly controlled and directed, though great in volume, may be less effective than a smaller volume better handled.

The firing line barring a few exceptional cases, then, should be as heavy as practicable consistent with the men's free use of their rifles.

This has been found to be about one man to the yard. In this way you get volume of fire and the companies do not cover so much ground that their commanders lose their power to direct and control.

If it becomes necessary to hold a line too long for the force available, it is then better to keep the men close together and leave gaps in the line. The men are so much better controlled, the fire better directed, the volume the same, and the gaps are closed by the cross fire of parties adjacent.

FOOTNOTES:

[11] In the preparation of the first part of this chapter, extracts of words and of ideas, were made from a paper on Applied Minor Tactics read before the St. Louis convention of the National Guard of the United States in 1910, by Major J. F. Morrison, General Staff, U. S. Army.

[12] The word "*mission*" is used a great deal in this text. By your "*mission*" is meant your business, what you have been told to do, what you are trying to accomplish.

GENERAL PLAN OF INSTRUCTION IN MAP PROBLEMS FOR NONCOMMISSIONED OFFICERS AND PRIVATES—INSTRUCTION IN DELIVERING MESSAGES

(The large wall map to be used for this instruction can be obtained from the George Banta Publishing Co., Menasha, Wis., at a cost of \$1.50.)

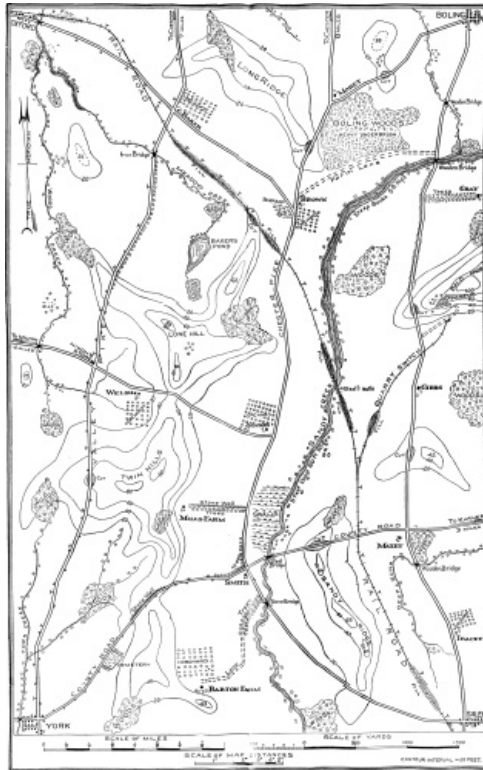

Elementary Map ([click to enlarge](#))

954. The noncommissioned officers and the privates of the squad, section, platoon or company are seated in front of the instructor, who, with pointer in hand, is standing near the map on the wall.

The instructor assumes certain situations and designates various noncommissioned officers to take charge of squads for the purpose of accomplishing certain missions; he places them in different situations, and then asks them what they would do. He, or the noncommissioned officer designated to perform certain missions, designates certain privates to carry messages, watch for signals, take the place of wounded noncommissioned officers, etc. For example, the instructor says: "The battalion is marching to Watertown (see [Elementary Map](#) in pocket at back of book) along this road (indicating road): our company forms the advance guard; we are now at this point (indicating point). Corporal Smith, take your squad and reconnoiter the woods on the right to see if you can find any trace of the enemy there, and rejoin the company as soon as you can. Corporal Jones, be on the lookout for any signals that Corporal Smith may make."

Corporal Smith then gives the command, "**1. Forward, 2. March,**" and such other commands as may be necessary.

Instructor: Now, when you reach this point (indicating point), what do you see?

(Corporal Smith holds his rifle horizontally above his head.)

Corporal Jones: Captain, Corporal Smith signals that he sees a small body of the enemy.

Corporal Smith: Lie down. Range, 700. **1. Ready; 2. AIM; 3. Squad; 4. FIRE. 1. Forward; Double time; 2. MARCH,** etc.

The noncommissioned officers and the privates who are thus designated to do certain things must use their imagination as much as possible. They must look at the map and imagine that they are right on the ground, in the hostile territory; they must imagine that they see the streams, hills, woods, roads, etc., represented on the map, and they must not do anything that they could not do if in the hostile territory, with the assumed conditions actually existing.

955. The general idea of this system of instruction is to make the noncommissioned officers and the privates think, to make them use common sense and initiative in handling men in various

situations, in getting out of difficulties. By thus putting men on their mettle in the presence of their comrades and making them bring into play their common sense and their powers of resourcefulness, it is comparatively easy to hold the attention of a whole squad, section, platoon or company, for those who are not actually taking part in the solution of a particular problem are curious to see how those who are taking part will answer different questions and do different things—how they will "pan out."

956. Everything that is said, everything that is done, should, as far as practicable, be said and done just as it would be said and done in the field. The commands should be actually given, the messages actually delivered, the reports actually made, the orders and instructions actually given, the signals actually made, etc., just the same as they would be if the operations were real. Of course, sometimes it is not practicable to do this, and again at other times it would be advisable not to do so. If, for instance, in the solution of a problem there were a great many opportunities to give commands to fire, to make signals, to deliver messages, etc., and if these things were actually done every time, it would not only become tiresome but it would also delay the real work and instruction. Common sense must be used. Just bear this in mind: In the solution of map problems the noncommissioned officers and the privates are to be given proper and sufficient instruction in giving commands, making signals, sending and delivering messages, making reports, etc., the instructor using his common sense in deciding what is proper and sufficient instruction. In carrying out this feature of the instruction it would be done thus, for instance:

Instead of a platoon leader saying, "I would give the order for the platoon (two, three or four squads) to fire on them," he would say, for instance, "I would then give the command, '**AT LINE OF MEN. RANGE, 600. FIRE AT WILL,**' and would continue the firing as long as necessary." Should the instructor then say, for instance, "Very well; the enemy's fire has slackened; what will you do now?" The platoon leader would answer, for instance, "I would signal: **1. By squads from the right; 2. RUSH.**"

Instead of saying, for instance, "I would advance my squad to the top of this hill at double time," the squad leader should say, "I would give the command: '**1. Forward, double time; 2. MARCH,**' and upon reaching the top of this hill, I would command, '**1. Squad; 2. HALT,**' cautioning the men to take advantage of cover."

Instead of saying, "I would signal back that we see the enemy in force," the squad leader should take a rifle and make the signal, and if a man has been designated to watch for signals, the man would say to the captain (or other person for whom he was watching for signals): "Captain, Corporal Smith has signaled that he sees the enemy in force."

Instead of saying, "I would send a message back that there are about twenty mounted men just in rear of the Jones' house; they are dismounted and their horses are being held by horseholders," say, "Smith, go back and tell the captain (or other person) there are about twenty mounted men just in rear of the Jones' house. They are dismounted and their horses are being held by horseholders." Private Smith would then say to the captain (or other person), "Captain, Corporal Harris sends word there are about twenty men just in the rear of the Jones' house. They are dismounted and their horses are being held by horse holders."

[Pg 272]

957. For problems exemplifying this system of instruction, see [Par. 1017](#).

The instruction may be varied a little by testing the squad leaders in their knowledge of map reading by asking, from time to time during the solution of the problem, such questions as these:

Captain: Corporal Smith, you are standing on Lone Hill (See [Elementary Map](#)), facing north. Tell me what you see?

Corporal: The hill slopes off steeply in front of me, about eighty feet down to the bottom land. A spur of the hill runs off on my right three-fourths of a mile to the north. Another runs off on my left the same distance to the west. Between these two spurs, down in front of me, is an almost level valley, extending about a mile to my right front, where a hill cuts off my view. To my left front it is level as far as I can see. A quarter of a mile in front of me is a big pond, down in the valley, and I can trace the course of a stream that drains the pond off to the northwest, by the trees along its bank. Just beyond the stream a railroad runs northwest along a fill and crosses the stream a mile and a half to the northwest, where I can see the roofs of a group of houses. A wagon road runs north across the valley, crossing the western spur of this hill 600 yards from Lone Hill. It is bordered by trees as far as the creek. Another road parallels the railroad, the two roads crossing near a large orchard a mile straight to my front.

Captain: Can you see the Chester Pike where the railroad crosses it?

Corporal: No, sir.

Captain: Why?

Corporal: Because the hill "62," about 800 yards from Lone Hill, is so high that it cuts off my view in that direction of everything closer to the spur "62" than the point in the Salem-Boling road, where the private lane runs off east to the Gray house.

Captain: Sergeant Jones, in which direction does the stream run that you see just south of the Twin Hills?

Sergeant: It runs south through York, because I can see that the northern end starts near the head of a valley and goes down into the open plain. Also it is indicated by a very narrow line near the Twin Hills which becomes gradually wider or heavier the further south it goes. Furthermore, the fact that three short branch streams are shown joining together and forming one, must naturally mean that the direction of flow is towards the one formed by the three.

Captain: Sergeant Harris, does the road from the Mason farm to the Welsh farm run up or down hill?

Sergeant: It does both, sir. It is almost level for the first half mile west of the Mason farm; then, as it crosses the contour marked 20 and a second marked 40, it runs up hill, rising to forty feet above the valley, 900 yards east of the Mason farm. Then, as it again crosses a contour marked 40 and a second marked 20, it goes down hill to the Welsh farm. That portion of the road between the points where it crosses the two contours marked 40, is the highest part of the road. It crosses this hill in a "saddle," for both north and south of this summit on the road are contours marked 60 and even higher.

[Pg 273]

Captain: Corporal Wallace, you are in Salem with a patrol with orders to go to Oxford. There is no one to tell you anything about this section of the country and you have never been there before. You have this map and a compass. What would you do?

Corporal: I would see from my map and by looking around me that Salem is situated at the crossing of two main roads. From the map I would see that one leads to Boling and the other was the one to take for Oxford. Also, I would see that the one to Boling started due north out of Salem and the other, the one I must follow, started due west out of Salem. Taking out my compass, I would see in what direction the north end of the needle pointed; the road running off in that direction would be the one to Boling, so I would start off west on the other.

Captain: Suppose you had no compass?

Corporal: I would look and see on which side of the base of the trees the moss grew. That side would be north. Or, in this case, I would probably not use a compass even if I had it; for, from the map, I know that the road I wish to start off on crosses a railroad track within sight of the crossroads and on the opposite side of the crossroads from the church shown on the map; also, that the Boling road is level as far as I could see on the ground, while the Chester Pike crosses the spur of Sandy Ridge, about a half mile out of the village.

Captain: Go ahead, corporal, and explain how you would follow the proper route to Oxford.

Corporal: I would proceed west on the Chester Pike, knowing I would cross a good sized stream, on a stone bridge, about a mile and a half out of Salem; then I would pass a crossroad and find a swamp on my right, between the road and the stream. About a mile and a half from the crossroad I just mentioned, I would cross a railroad track and then I would know that at the fork of the roads one-quarter of a mile further on I must take the left fork. This road would take me straight into Oxford, about a mile and three-quarters beyond the fork.

Captain: Sergeant Washington, do the contours about a half mile north of the Maxey farm, on the Salem-Boling road, represent a hill or a depression?

Sergeant: They represent a hill, because the inner contour has a higher number 42, than the outer, marked 20. They represent sort of a leg-of-mutton shaped hill about 42 feet higher than the surrounding low ground.

Variety and interest may be added to the instruction by assuming that the squad leader has been killed or wounded and then designate some private to command the squad; or that a man has been wounded in a certain part of the body and have a soldier actually apply his first aid packet; or that a soldier has fainted or been bitten by a rattlesnake and have a man actually render him first aid.

[Pg 274]

958. The privates may be given practical instruction in delivering messages by giving them messages in one room and having them deliver them to someone else in another room. It is a good plan to write out a number of messages in advance on slips of paper or on cards, placing them in unsealed envelopes. An officer or a noncommissioned officer in one room reads one of the messages to a soldier, then seals it in an envelope and gives it to the soldier to hand to the person in another room to whom he is to deliver the message. The latter checks the accuracy of the message by means of the written message. Of course, this form of instruction should not be given during the solution of map problems by the men. (For model messages, see [par. 980.](#))

The same slips or cards may be used any number of times with different soldiers. A soldier should never start on his way to deliver a message unless he understands thoroughly the message he is to deliver.

THE SERVICE OF INFORMATION

(Based on the Field Service Regulations.)

PATROLLING

959. Patrols are small bodies of infantry or cavalry, from two men up to a company or troop, sent out from a command at any time to gain information of the enemy and of the country, to drive off small hostile bodies, to prevent them from observing the command or for other stated objects, such as to blow up a bridge, destroy a railroad track, communicate or keep in touch with friendly troops, etc. Patrols are named according to their objects, reconnoitering, visiting, connecting, exploring, flanking patrols, etc. These names are of no importance, however, because the patrol's orders in each case determine its duties.

960. The size of a patrol depends upon the mission it is to accomplish; if it is to gain information only, it should be as small as possible, allowing two men for each probable message to be sent (this permits you to send messages and still have a working patrol remaining); if it is to fight, it should be strong enough to defeat the probable enemy against it. For instance, a patrol of two men might be ordered to examine some high ground a few hundred yards off the road. On the other hand, during the recent war in Manchuria a Japanese patrol of 50 mounted men, to accomplish its mission marched 1,160 miles in the enemy's country and was out for 62 days.

961. Patrol Leaders. (a) Patrol leaders, usually noncommissioned officers, are selected for their endurance, keen eyesight, ability to think quickly and good military judgment. They should be able to read a map, make a sketch and send messages that are easily understood. Very important patrols are sometimes lead by officers. The leader should have a map, watch, field glass, compass, message blank and pencils.

(b) The ability to lead a patrol correctly without a number of detailed orders or instructions, is one of the highest and most valuable qualifications of a noncommissioned officer. Since a commander ordering out a patrol can only give general instructions as to what he desires, because he cannot possibly foresee just what situations may arise, the patrol leader will be forced to use his own judgment to decide on the proper course to pursue when something of importance suddenly occurs. He is in sole command on the spot and must make his decisions entirely on his own judgment and make them instantly. He has to bear in mind first of all his mission—what his commander wants him to do.

Possibly something may occur that should cause the patrol leader to undertake an entirely new mission and he must view the new situation from the standpoint of a higher commander.

(c) More battles are lost through lack of information about the enemy than from any other cause, and it is the patrols led by noncommissioned officers who must gather almost all of this information. A battalion or squadron stands a very good chance for defeating a regiment if the battalion commander knows all about the size, position and movements of the regiment and the regimental commander knows but a little about the battalion; and this will all depend on how efficiently the patrols of the two forces are led by the noncommissioned officers.

[Pg 276]

962. Patrols are usually sent out from the advance party of an advance guard, the rear party of a rear guard, the outguards of an outpost, and the flank (extreme right or left) sections, companies or troops of a force in a fight, but they may be sent out from any part of a command.

The commander usually states how strong a patrol shall be.

963. Orders or Instructions—(a) The orders or instructions for a patrol must state clearly whenever possible:

1. Where the enemy is or is supposed to be.
2. Where friendly patrols or detachments are apt to be seen or encountered and what the plans are for the body from which the patrol is sent out.
3. What object the patrol is sent out to accomplish; what information is desired; what features are of special importance; the general direction to be followed and how long to stay out in case the enemy is not met.
4. Where reports are to be sent.

(b) It often happens that, in the hurry and excitement of a sudden encounter or other situation, there is no time or opportunity to give a patrol leader anything but the briefest instructions, such as "Take three men, corporal, and locate their (the enemy's) right flank." In such a case the patrol leader through his knowledge of the general principles of patrolling, combined with the exercise of his common sense, must determine for himself just what his commander wishes him to do.

964. Inspection of a Patrol Before Departure. Whenever there is time and conditions permit, which most frequently is not the case, a patrol leader carefully inspects his men to see that they are in good physical condition; that they have the proper equipment, ammunition and ration; that their canteens are full, their horses (if mounted) are in good condition, not of a conspicuous color and not given to neighing, and that there is nothing about the equipment to rattle or glisten. The patrol leader should also see that the men have nothing with them (maps, orders, letters, newspapers, etc.) that, if captured, would give the enemy valuable information. This is a more important inspection than that regarding the condition of the equipment.

Whenever possible the men for a patrol should be selected for their trustworthiness, experience and knack of finding their way in a strange country.

965. Preparing a Patrol for the Start. The patrol leader having received his orders and having asked questions about anything he does not fully understand, makes his estimate of the situation (See [Par. 950](#).) He then selects the number of men he needs, if this has been left to him, inspects them and carefully explains to them the orders he has received and how he intends to carry out these orders, making sure the men understand the mission of the patrol. He names some prominent place along the route they are going to follow where every one will hasten if the patrol should become scattered.

[Pg 277]

For example: An infantry company has arrived at the town of York (See [Elementary Map](#)). Captain A, at 2 P. M., calls up Corporal B and three men of his squad.

Captain A: Corporal, hostile infantry is reported to be at Oxford. Nothing else has been heard of the enemy. The company remains here tonight. You will take these three men and reconnoiter about two miles north along this road (indicates the Valley Pike) for signs of a hostile advance in this direction.

Stay out until dusk.

Corporal C has been sent out that road (points east along the county road).

Send messages here. Do you understand?

Corporal B: Yes, sir; I am to—(here he practically repeats Captain A's orders, the three men listening). Is Corporal C to cover that hill (points toward Twin Hills)?

Captain A: No; you must cover that ground. Move out at once, corporal. (Corporal B quickly glances at the men and sees that they have their proper equipment.)

Corporal B (to his men): You heard the captain's orders. We will make for that hill (points to Twin Hills). Jones, I want you to go 150 yards in advance of me; Williams, follow me at 100 yards; Smith, you'll stay with me. Jones, you'll leave this road after crossing the creek and march on that clump of trees. I want both you and Williams to be on the alert and watch me every minute for signals. In case we become scattered, make for that hill (points to Twin Hills).

Private Jones: Corporal, shall I keep 150 yards from you or will you keep the correct distance?

Corporal B: You keep the correct distance from me. Forward, Jones.

Of course, the patrol leader makes all these preparations if he has time; but, as we have said before, there will be a great many occasions when he is required to start out so promptly that he will not have any time for the inspection described and he will have to make an estimate of the situation and give his detailed orders to the members of his patrol as they start off.

966. Co-ordination Before Departure. Every member of a patrol should notice for himself the direction taken and all landmarks that are passed, and every man should keep his eyes and ears open all the time. Before leaving an outpost position or other place to which it is to return, the patrol commander should "co-ordinate" himself—he should see where he is with respect to certain mountains, high buildings and other prominent objects, and after the patrol has left, he should frequently turn his head around and see what the starting point looks like from where he is. This will help him to find his way back without difficulty.

[Pg 278]

THE PRINCIPLES OF PATROLLING

967. Paragraphs 967 to 1015 describe the methods of leading a patrol—the points a patrol leader should fully understand. In other words, they state the principles of patrolling. When you first study this chapter, simply read over these principles without trying to memorize any of them. Whenever one of the principles is applied in the solution of any of the problems on patrolling given in this book you will generally find the number of the paragraph which states that principle enclosed in brackets. Turn back and study the paragraph referred to until you thoroughly understand its meaning and you feel sure that you know how to apply that principle whenever the occasion might arise in actual patrolling. Try to impress its common sense meaning (never the mere words) on your mind, so that when a situation arises requiring the sort of action indicated in the principle, YOU WILL NOT FAIL TO RECOGNIZE IT.

968. Formation of Patrols.

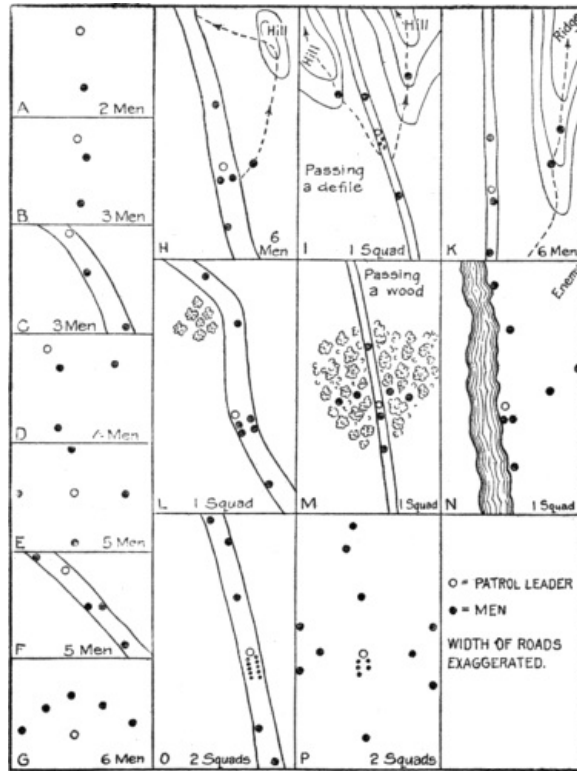

Figure 1

(a) [Figure 1](#) gives some examples of various ways of forming patrols. These are merely examples for the purpose of giving a general idea of the arrangement of the men. In practice common sense must dictate to the patrol leader the best formation in each case.

(b) In very small patrols the leader is usually in advance where he can easily lead the patrol, though not always (See E, [Figure 1](#).) The distance between men depends upon the character of the country and the situation. In L, [Figure 1](#), it might be anywhere from 150 to 400 yards from the leading man to the last, the distance being greater in level or open country. Some such formation as G, [Figure 1](#), could be used in going through high brush, woods, or over very open country.

[Pg 279]

(c) The men must be so arranged that each man will be within signaling distance of some member of the patrol and the escape of at least one man, in case of surprise, is certain.

It must be remembered that the patrol may have to march a long distance before it is expected that the enemy will be encountered, or it may have a mission that requires it to hurry to some distant point through very dangerous country. In such cases the patrol will probably have to follow the road in order to make the necessary speed, and it will not be possible for flankers to keep up this rate marching off the road. The formation in such cases would be something like those shown in F, II and O.

Marching off the road is always slow work, so when rapidity is essential, some safe formation for road travel is necessary, as in F, L and O.

If, from the road the country for, say one-half mile on each side, can be seen, there is absolutely no use in sending out flankers a few hundred yards from the road. Use common sense.

969. Rate of March. (a) Patrols should advance quickly and quietly; be vigilant and make all practicable use of cover. If rapid marching is necessary to accomplish the mission, then little attention can be paid to cover.

(b) Returning patrols, near their own lines, march at a walk, unless pressed by the enemy. A patrol should not, if possible, return over its outgoing route, as the enemy may have observed it and be watching for its return.

970. Halts. A patrol should be halted once every hour for about ten minutes, to allow the men to rest and relieve themselves. Whenever a halt is made one or two members of the patrol must advance a short distance ahead and keep a sharp lookout to the front and flanks.

971. Action Upon Meeting Hostile Patrol. If a patrol should see a hostile patrol, it is generally best to hide and let it go by, and afterwards look out for and capture any messenger that may be sent back from it with messages for the main body. And when sent back yourself with a message, be careful that the enemy does not play this trick on you—always keep your ears and eyes open.

972. Scattered Patrols. A scattered patrol reassembles at some point previously selected; if checked in one direction, it takes another; if cut off, it returns by a detour or forces its way

through. As a last resort it scatters, so that at least one man may return with information.

Occasionally it is advisable for the leader to conceal his patrol and continue the reconnaissance with one or two men; in case of cavalry the leader and men thus detached should be well mounted. If no point of assembly was previously agreed upon, it is a good general rule to reassemble, if possible, at the last resting place.

[Pg 280]

973. Return by Different Route. A patrol should always make it a rule to return by a different route, as this may avoid its being captured by some of the enemy who saw it going out and are lying in wait for it.

974. Guard Against Being Cut off. When out patrolling always guard against being cut off. Always assume that any place that affords good cover is held by the enemy until you know that it is not, and be careful not to advance beyond it without first reconnoitering it; for, if you do, you may find yourself cut off when you try to return.

975. Night Work. Patrols far from their commands or in contact with the enemy, often remain out over night. In such cases they seek a place of concealment unknown to the inhabitants, proceeding thereto after nightfall or under cover. Opportunities for watering, feeding and rest must not be neglected, for there is no assurance that further opportunities will present themselves. When necessary the leader provides for subsistence by demand or purchase.

976. Civilians: In questioning civilians care must be taken not to disclose information that may be of value to the enemy. Strangers must not be allowed to go ahead of the patrol, as they might give the enemy notice of its approach. Patrol leaders are authorized to seize telegrams and mail matter, and to arrest individuals, reporting the facts as soon as possible.

977. Patrol Fighting. (a) A patrol sent out for information never fights unless it can only get its information by fighting or is forced to fight in order to escape. This principle is the one most frequently violated by patrol leaders, particularly in peace maneuvers. They forget their mission—the thing their commander sent them out to do—and begin fighting, thus doing harm and accomplishing no important results.

(b) A patrol sent out to drive off hostile detachments has to fight to accomplish its mission. Sometimes a patrol has orders both to gain information and to drive back hostile patrols. In this case it may be proper to avoid a fight at one moment and to seek a fight at another. The patrol leader must always think of his mission when deciding on the proper course to follow, and then use common sense.

978. Signals. The following should be clearly understood by members of a patrol:

Enemy in sight in small numbers: Hold the rifle above the head horizontally.

Enemy in force: Same as preceding, raising and lowering the rifle several times.

Take cover: A downward motion of the hand.

Other signals may be agreed upon before starting, but they must be simple and familiar to the men; complicated signals must be avoided. Signals must be used cautiously, so as not to convey information to the enemy.

The patrol leader should see that all his men thoroughly understand that whenever they are away from the center of the patrol they must look to the nearest man for signals at least once every minute. It should never be necessary for the patrol leader to call to a man in order to get his attention. All movements of men at a distance should be regulated by signals and the men should constantly be on the lookout for these signals.

[Pg 281]

979. Messages. (a) The most skillful patrol leading is useless unless the leader fully understands when to send a message and how to write it.

(b) A message, whether written or verbal, should be short and clear, resembling a telegram. If it is a long account it will take too much time to write, be easily misunderstood, and if verbal, the messenger will usually forget parts of it and confuse the remainder.

(c) Always state when and where things are seen or reported. If haste is required, do not use up valuable moments writing down the day of the month, etc. These data are essential as a matter of future record for formal telegrams and should be put in patrol messages only when time is abundant, but never slight the essential points of information that will give valuable help to your chief. Always try to put yourself in his place—not seeing what you see and read your message—and then ask yourself, What will he want to know?

(d) The exact location of the enemy should be stated; whether deployed, marching or in camp, his strength, arm of the service (cavalry, infantry or artillery), and any other detail that you think would be valuable information for your chief. In giving your location do not refer to houses, streets, etc., that your chief in the rear has no knowledge of. Give your direction and distance from some point he knows of or, if you have a map like his, you can give your map location.

(e) Be sure your message is accurate. This does not mean that something told you should not be reported, but it should be reported, not as a fact, but as it is—a statement by somebody else. It is well to add any information about your informant, such as his apparent honesty, the probability of his having correct information, etc.—this may help your chief.

(f) A message should always end with a short statement of what you are going to do next. For example: "Will remain in observation," "Will continue north," "Will work around to their rear," etc. Time permitting, the bearer of a verbal message should always be required to repeat it before leaving.

(g) The following is a reproduction of a message blank used in field service. The instructions on the envelope are also given. A patrol leader will usually be furnished with a pad of these blanks:

[Pg 282]

U. S. ARMY FIELD MESSAGE		No.	Sent by	Time	Rec'd by	Time	Check
(These spaces for Signal Operators only)							
Communicated by		(Name of sending detachment)					
Buzzer, Phone, Telegraph, Wireless, Lantern, Heliograph, Flag, Cyclist, Foot Messenger, Mounted Messenger. Underscore means used		From _____					
		(Location of sending detachment)					
		At _____					
		Date	Hour	No.			
To _____							

Received _____							

The heading "From" is filled in with the *name* of the detachment sending the information, as "Officer's Patrol, 7th Cav". Messages sent on the same day from the same source to the same person are numbered consecutively. The address is written briefly, thus, "Commanding Officer, Outpost, 1st Brigade". In the signature the writer's surname only and rank are given.

This blank is four and a half by eight inches, including the margin on the left for binding. The back is ruled in squares and provided with scales for use in making simple sketches explanatory of the message. It is issued by the Signal Corps in blocks of forty with duplicating sheets. The regulation envelope is three by five and one fourth inches and is printed as follows:

U. S. ARMY FIELD MESSAGE

To..... No.....
(For Signal operators only)

When sent No.

Rate of speed

Name of Messenger

When and by whom rec'd

THIS ENVELOPE WILL BE RETURNED TO BEARER

MODEL MESSAGES

980. 1. Verbal. "Four hostile infantrymen one mile north of our camp, moving south. I will continue north."

2. Verbal. "About one hundred hostile infantrymen two miles north of our camp at two o'clock, marching south. Will observe them."

[Pg 283]

3. Verbal. "Long column of troops marching west in Sandy Creek Valley at two o'clock. Will report details later."

4. Verbal. "Just fired on by cavalry patrol near Baker's Pond. Will work to their rear."

5. Written.

Patrol from Support No 2.
Lone Hill,
26 Mch. 11, 8-15 A. M., No. 1.

C. O.,
Support No. 2.

See hostile troop of cavalry halted at x-roads, one mile S. of our outguards. Nothing else in sight. Will remain here in observation.

James,
Corporal.

6. Written (very hurriedly).

Lone Hill, 8-30, No 2.

C. O.,
Support No. 2.

Column of about 300 hostile cavalry trotting north towards hostile troop of cavalry now halted at x-roads one mile south of our outguards. Will remain here.

James,
Cpl.

7. Written.

Patrol from 5th Inf.,
S. E. corner Boling Woods,
3 Apl. 11, 2-10 P. M., No. 2.

Adjutant,
5th Inf., near Baker House.

Extreme right of hostile line ends at R. R. cut N. E. of BAKER'S POND. Entrenchments run S. from cut along crest of ridge. Line appears to be strongly held. Can see no troops in rear of line. Will reconnoiter their rear.

Smith,
Sergeant.

8. Written (from cavalry patrol far to front).

Patrol from Tr. B, 7th Cav.,
Boling,
14 June, 12, 10 A. M., No. 3.

To C. O.,
Tr. B, 7th Cav.,
S. on Chester Pike.

No traces of enemy up to this point. Telegraph operator here reports wires running north from Boling were cut somewhere at 8-30 A. M. Inhabitants appear friendly. Will proceed north.

Jones,
Sergeant.

9. Written (from cavalry patrol far to front).

Patrol from Tr B, 7th Cav.,
Oxford,
8 July, 12, 10-15 A. M., No. 2.

To C. O.,
1st Sq. 7th Cav.,
On Valley Pike, S. of York.

[Pg 284]

Bearer has canteen found in road here, marked "85 CAV.—III CORPS." Inhabitants say no enemy seen here. They appear hostile and unreliable. No telegraph operator or records remain here. Roads good macadam. Water and haystacks plentiful. Will move rapidly on towards CHESTER.

Lewis,
Sergeant.

Patrol from Support No. 3,
On Ry. $\frac{3}{4}$ mi. N. of County Road,
2 Aug. 12, 9-15 P. M., No. 1.

C. O.,
Support No. 2,
Near Maxey House.

R. R. crosses creek here on 80-foot steel trestle. Hostile detachment is posted at N. end. Strength unknown. Creek 5 ft. deep by 60 ft. wide, with steep banks, 5 ft. high. Flows through meadow land. Scattered trees along banks. R. R. approaches each end of trestle on 10-foot fill. R. R. switch to N. E. 700 yds. S. of bridge. (See sketch on back.) I will cross creek to N. of bridge.

981. A message should be sent as soon as the enemy is first seen or reported. Of course, if the enemy is actually known to be in the vicinity and his patrols have been seen, etc., you must by all means avoid wasting your men by sending them back with information about small hostile patrols or other things you know your chief is already aware of and did not specifically tell you to hunt for.

If you have properly determined in your own mind what your mission is then you will have no trouble in deciding when to send messages. For example, suppose your orders are "To reconnoiter along that ridge and determine if the enemy is present in strength," and you sight a patrol of eight men. You would waste no time or men sending back any message about the patrol, for your mission is to find out if strong bodies of the enemy are about. But suppose that while working under the above orders you located a hostile battalion of infantry—a large body of troops. In this case you would surely send a detailed message, as your mission is to determine if the enemy was present in strength.

Again, suppose that while moving towards the ridge indicated by your chief in his orders, you saw his force suddenly and heavily fired on from a new and apparently unexpected quarter, not a great distance from you, but not on the ridge referred to. You know or believe none of your patrols are out in that neighborhood. In this case you should realize instantly, without any order, that your mission had changed and you should hasten to discover the size and position of this new enemy and send the information back to your chief, first notifying him of your intended change of direction.

Never forget your mission in the excitement of leading your own little force.

[Pg 285]

982. Absence of the Enemy. It is frequently just as important to send a message to your chief that the enemy is not in a certain locality as it is to report his actual whereabouts. You must determine from your mission when this is the case. For example, if you were ordered "To patrol beyond that woods and see if any hostile columns are moving in that direction," and on reaching the far side of the woods you had a good view of the country for some distance beyond, it would be very important to send a message back telling your chief that you could see, say, one-half mile beyond the woods and there was no enemy in sight. This information would be of the greatest importance to him. He might feel free to move troops immediately from that vicinity to some more dangerous place. You would then continue your reconnaissance further to the front.

Suggestions for Gaining Information About the Enemy

983. Enemy on the March. (a) The patrol should observe the march of the column from a concealed position that hostile patrols or flankers are not apt to search (avoid conspicuous places). Always try to discover if one hostile detachment is followed by another—if what can be seen appears to be an advance guard of a larger body not yet in view. The distance between the detachments, their relative size, etc., is always important.

(b) **Estimating Strength of Column.** The strength of a column may be estimated from the length of time it takes to pass a selected point. As infantry in column of squads occupies half a yard per man, cavalry one yard per horse and artillery in single file twenty yards per gun or caisson (ammunition wagon), a selected point would be passed in one minute by 175 infantry; 110 cavalry (at a walk); 200 cavalry at a trot and 5 guns or caissons. If marching in columns of twos, take one-half of the above figures.

(c) **Dust.** The direction of march, strength and composition (infantry, cavalry or artillery) of a column can be closely estimated from the length and character of the cloud of dust that it makes. Dust from infantry hangs low; from cavalry it is higher, disperses more quickly, and, if the cavalry moves rapidly, the upper part of the cloud is thinner; from artillery and wagons, it is of unequal height and disconnected. The effect of the wind blowing the dust must be considered.

(d) **Trail of Column.** Evenly trodden ground indicates infantry; prints of horseshoes mean cavalry and deep and wide wheel tracks indicate artillery. If the trail is fresh, the column passed recently; if narrow, the troops felt secure and were marching in column of route; if broad they expected an action and were prepared to deploy. A retreating army makes a broad trail across fields, especially at the start.

Always remember that the smallest or most insignificant things, such as the number of a regiment or a discarded canteen or collar ornament, may give the most valuable information to a higher commander. For example, the markings on a discarded canteen or knapsack might prove to a general commanding an army that a certain hostile division, corps, or other force was in front of him when he thought it had not been sent into the field. The markings on the canteen would convey little or no meaning to the patrol leader, but if he realized his duty he would take care to report the facts. Cavalry patrols working far ahead of the foot troops should be most careful to observe and report on such details.

[Pg 286]

(e) **Reflection of Weapons.** If brilliant, the troops are marching toward you, otherwise they are

probably marching away from you.

Enemy in Position. (a) If an outpost line, the patrol locates the line of sentinels, their positions, the location and strength of the outguards and, as far as possible, all troops in rear. The location of the flanks of the line, whether in a strong or weak position, is of the utmost importance. Places where the line may be most easily penetrated should be searched for and the strength and routes of the hostile patrols observed.

As outposts are usually changed at dawn this is the best time to reconnoiter their positions.

(b) A hostile line of battle is usually hard to approach, but its extent, where the flanks rest and whether or not other troops are in rear of these flanks, should be most carefully determined.

Information as to the flanks of any force, the character of the country on each flank, etc., is always of the greatest importance, because the flanks are the weakest portions of a line. In attacking an enemy an effort is almost always made to bring the heaviest fire or blow to bear on one of his flanks. Naturally all information about this most vulnerable part of an enemy is of great importance.

984. Prisoners. When a patrol is ordered to secure prisoners they should be questioned as soon as captured, while still excited and their replies can in a way be verified. Their answers should be written down (unknown to them) and sent back with them as a check on what they may say on second thought.

Prisoners should always be questioned as to the following points: What regiment, brigade, division, etc., they belong to; how long they have been in position, on the march, etc.; how much sickness in their organization; whether their rations are satisfactory; who commands their troops, etc. Always try to make the prisoners think the questions are asked out of mere curiosity.

985. Camp Noises. The rumble of vehicles, cracking of whips, neighing of horses, braying of mules and barking of dogs often indicate the arrival or departure of troops. If the noise remains in the same place and new fires are lighted, it is probable that reënforcements have arrived. If the noise grows more indistinct, the troops are probably withdrawing. If, added to this, the fires appear to be dying out, and the enemy seems to redouble the vigilance of the outposts, the indications of retreat are strong.

986. Abandoned Camps. (a) Indications are found in the remains of camp fires. They will show, by their degree of freshness, whether much or little time elapsed since the enemy left the place, and the quantity of cinders will give an indication of the length of time he occupied it. They will also furnish a means of estimating his force approximately, ten men being allowed to each fire.

[Pg 287]

(b) Other valuable indications in regard to the length of time the position was occupied and the time when it was abandoned may be found in the evidence of care or haste in the construction of huts or shelters, and in the freshness of straw, grain, dung or the entrails of slaughtered animals. Abandoned clothing, equipments or harness will give a clue to the arms and regiments composing a retreating force. Dead horses lying about, broken weapons, discarded knapsacks, abandoned and broken-down wagons, etc., are indications of the fatigue and demoralization of the command. Bloody bandages lying about, and many fresh graves, are evidences that the enemy is heavily burdened with wounded or sick.

987. Flames or Smoke. If at night the flames of an enemy's camp fires disappear and reappear, something is moving between the observer and the fires. If smoke as well as flame is visible, the fires are very near. If the fires are very numerous and lighted successively, and if soon after being lighted they go out it is probable the enemy is preparing a retreat and trying to deceive us. If the fires burn brightly and clearly at a late hour, the enemy has probably gone, and has left a detachment to keep the fires burning. If, at an unusual time, much smoke is seen ascending from an enemy's camp, it is probable that he is engaged in cooking preparatory to moving off.

If lines of smoke are seen rising at several points along a railway line in the enemy's rear, it may be surmised that the railroad is being destroyed by burning the crossties, and that a retreat is planned.

988. Limits of vision. (a) On a clear day a man with good vision can see:

- At a distance of 9 to 12 miles, church spires and towers;
- At a distance of 5 to 7 miles, windmills;
- At a distance of 2¹/₂ miles, chimneys of light color;
- At a distance of 2,000 yards, trunks of large trees;
- At a distance of 1,000 yards, single posts;
- At 500 yards the panes of glass may be distinguished in a window.

(b) Troops are visible at 2,000 yards, at which distance a mounted man looks like a mere speck; at 1,200 yards infantry can be distinguished from cavalry; at 1,000 yards a line of men looks like a broad belt; at 600 yards the files of a squad can be counted, and at 400 yards the movements of the arms and legs can be plainly seen.

(c) The larger, brighter or better lighted an object is, the nearer it seems. An object seems nearer when it has a dark background than when it has a light one, and closer to the observer when the air is clear than when it is raining, snowing, foggy or the atmosphere is filled with smoke. An object looks farther off when the observer is facing the sun than when he has his back to it. A smooth expanse of snow, grain fields or water makes distances seem shorter than they really are.

Suggestions for the Reconnaissance of Various Positions and Localities

[Pg 288]

989. Cross roads should be reconnoitered in each direction for a distance depending on how rapidly the patrol must continue on, how far from the main road the first turn or high point is, etc. The main body of the patrol usually remains halted near the crossroads, while flankers do the reconnoitering.

990. Heights. In reconnoitering a height, if the patrol is large enough to admit of detaching them, one or two men climb the slope on either flank, keeping in sight of the patrol, if possible. In any case, one man moves cautiously up the hill, followed by the others in the file at such distance that each keeps his predecessor in view.

991. Defiles. On approaching a defile, if time permits, the heights on either side are reconnoitered by flankers before the patrol enters. If the heights are inaccessible or time is urgent, the patrol passes through, in single file at double time. The same method is adopted in reconnoitering a railroad cut or sunken road.

992. Bridges and Fords. At a bridge or ford, the front of the patrol is contracted so as to bring all the men to the passage. The leading patrolers cross first and reconnoiter the far side to prevent the possibility of the enemy surprising the main body of the patrol as it is crossing the bridge. The patrol then crosses rapidly, and takes up a proper formation. A bridge is first examined to see that it is safe and has not been tampered with by the enemy.

993. Woods. The patrol enters a wood in skirmishing order, the intervals being as great as may be consistent with mutual observation and support on the part of the members of the patrol. On arriving at the farther edge of the wood, the patrol remains concealed and carefully looks about before passing out to open ground. When there is such a growth of underbrush as to make this method impracticable, and it is necessary to enter a wood by a road, the road is reconnoitered as in case of defile, though not usually at double time.

994. Enclosures. In reconnoitering an enclosure, such as a garden, park or cemetery, the leading patrolers first examine the exterior, to make sure that the enemy is not concealed behind one of the faces of the enclosure. They then proceed to examine the interior. Great care is taken in reconnoitering and entering an enclosure to avoid being caught in a confined or restricted space by the enemy.

995. Positions. In approaching a position, but one man advances (one is less liable to be detected than two or more), and he crawls cautiously toward the crest of the hill or edge of the wood or opening of the defile, while the others remain concealed in the rear until he signals them to advance.

996. Houses. When a house is approached by a patrol, it is first reconnoitered from a distance, and if nothing suspicious is seen, it is then approached by one or two men, the rest of the party remaining concealed in observation. If the patrol is large enough to admit of it, four men approach the house, so as to examine the front and back entrances at the same time. Only one man enters the door, the others remaining outside to give the alarm, should a party of the enemy be concealed in the house. The patrol does not remain in the vicinity of the house any longer than necessary, as information relative to its numbers and movements might be given to the enemy, if a hostile party should subsequently visit the place. Farmhouses are searched for newspapers and the inhabitants questioned. If necessary to go up to a building, wood or hill, where an enemy is likely to be concealed, run for the last couple of hundred yards, having your rifle ready for instant use, and make for some point that will afford you cover when you get close up. In the case of a building, for instance, you would make for one of the corners. Such a maneuver would probably be disconcerting to anyone who might be lying in wait for you, and would be quite likely to cause them to show themselves sooner than they intended, and thus give you a chance to turn around and get away. If they fired on you while you were approaching at a run, they would not be very likely to hit you.

[Pg 289]

997. Villages. (a) In approaching a small village one or two men are sent in to reconnoiter and one around each flank, but the main body does not enter until the scouts have reported. In small patrols of three to six men so much dispersion is not safe and only one section of the village can be reconnoitered at a time.

(b) If the presence of the enemy is not apparent, the patrol enters the village. A suitable formation would be in single file at proper distance, each man being on the opposite side of the street from his predecessor, thus presenting a more difficult target for hostile fire and enabling the men to watch all windows.

(c) If the patrol is strong enough, it seizes the postoffice, telegraph office and railroad stations,

and secures all important papers, such as files of telegrams sent and received, instructions to postmasters, orders of town mayor, etc., that may be there. If the patrol is part of the advance guard, it seizes the mayor and postmaster of the place and turns them over to the commander of the vanguard with the papers seized.

(d) While searching a village sentinels are placed at points of departure to prevent any of the inhabitants from leaving. Tall buildings and steeples are ascended and an extensive view of the surrounding country obtained.

(e) At night a village is more cautiously approached by a small party than by day. The patrol glides through back alleys, across gardens, etc., rather than along the main street. If there are no signs of the enemy, it makes inquiry. If no light is seen, and it seems imprudent to rouse any of the people, the patrol watches and captures one of the inhabitants, and gets from him such information as he may possess.

(f) The best time for the patrol to approach a village is at early dawn, when it is light enough to see, but before the inhabitants are up. It is dangerous in the extreme for a small patrol to enter a village unless it is certain that it is not occupied by the enemy, for the men could be shot down by fire from the windows, cellarways, etc., or entrapped and captured. As a rule large towns and cities are not entered by small patrols, but are watched from the outside, as a small force can not effectively reconnoiter and protect itself in such a place.

Facts Which Should Be Obtained by Patrols Regarding Certain Objects

[Pg 290]

998. Roads. Their direction, their nature (macadamized, corduroy plank, dirt, etc.), their condition of repair, their grade, the nature of crossroads, and the points where they leave the main roads; their borders (woods, hedges, fences or ditches), the places at which they pass through defiles, cross heights or rivers, and where they intersect railroads, their breadth (whether suitable for column of fours or platoons, etc.).

999. Railroads. Their direction, gauge, the number of tracks, stations and junctions, their grade, the length and height of the cuts, embankments and tunnels.

1000. Bridges. Their position, their width and length, their construction (trestle, girder, etc.), material (wood, brick, stone or iron), the roads and approaches on each bank.

1001. Rivers and Other Streams. Their direction, width and depth, the rapidity of the current, liability to sudden rises and the highest and lowest points reached by the water, as indicated by drift wood, etc., fords, the nature of the banks, kinds, position and number of islands at suitable points of passage, heights in the vicinity and their command over the banks.

1002. Woods. Their situation, extent and shape; whether clear or containing underbrush; the number and extent of "clearings" (open spaces); whether cut up by ravines or containing marshes, etc.; nature of roads passing through them.

1003. Canals. Their direction, width and depth; condition of tow-paths; locks and means of protecting or destroying them.

1004. Telegraphs. Whether they follow railroads or common roads; stations, number of wires.

1005. Villages. Their situation (on a height, in a valley or on a plain); nature of the surrounding country; construction of the houses, nature (straight or crooked) and width of streets; means of defense.

1006. Defiles. Their direction; whether straight or crooked; whether heights on either side are accessible or inaccessible; nature of ground at each extremity; width (frontage of column that can pass through).

1007. Ponds and Marshes. Means of crossing; defensive use that might be made of them as obstacles against enemy; whether the marshy grounds are practicable for any or all arms.

1008. Springs and Rivulets. Nature of approaches; whether water is drinkable and abundant.

1009. Valleys. Extent and nature; towns, villages, hamlets, streams, roads and paths therein; obstacles offered by or in the valley, to the movement of troops.

1010. Heights. Whether slopes are easy or steep; whether good defensive positions are offered; whether plateau is wide or narrow; whether passages are easy or difficult; whether the ground is broken or smooth, wooded or clear.

Suggestions for Patrols Employed in Executing Demolition

[Pg 291]

(Destruction or blocking of bridges, railroads, etc.)

1011. Patrols never execute any demolition unless specifically ordered to do so. Demolition may be of two different characters: Temporary demolition, such as cutting telegraph

wires in but a few places or merely burning the flooring of bridges, removing a few rails from a track, etc., and permanent demolition, such as cutting down an entire telegraph line, completely destroying bridges, blowing in tunnels, etc. Only temporary demolition will be dealt with in this book.

1012. Telegraph Line. To temporarily disable telegraph lines, connect up different wires close to the glass insulators, wrap a wire around all the wires and bury its ends in the ground (this grounds or short circuits the wire), or cut all the wires in one or two places.

1013. Railroads. To temporarily disable railroads remove the fish plates (the plates that join the rails together at the ends) at each end of a short section of track, preferably upon an embankment, then have as many men as available raise the track on one side until the ties stand on end and turn the section of track so that it will fall down the embankment; or, cut out rails by a charge of dynamite or gun cotton placed against the web and covered up with mud or damp clay. Eight to twelve ounces of explosive is sufficient. Or blow in the sides of deep cuts or blow down embankments. Bridges, culverts, tunnels, etc., are never destroyed except on a written order of the commander-in-chief.

1014. Wagon Road. (a) Bridges can be rendered temporarily useless by removing the flooring, or, in the case of steel bridges, by burning the flooring (if obtainable, pour tar or kerosene on flooring), particularly if there is not time to remove it.

Short culverts may sometimes be blown in.

A hastily constructed barricade across a bridge or in a cut of trees, wagons, etc, may be sufficient in some cases where only the temporary check of hostile cavalry or artillery is desired.

(b) The road bed may be blocked by digging trenches not less than thirty feet wide and six feet deep, but as this would take a great deal of time patrols would rarely be charged with such work.

1015. Report on Return of Patrol. On returning the patrol leaders should make a short verbal or written report, almost always the former, briefly recounting the movements of the patrol, the information obtained of the enemy, a description of the country passed over and of friendly troops encountered. Of course, this is not practicable when the situation is changing rapidly and a returning patrol is immediately engaged in some new and pressing duty.

Model Reports of Patrol Leaders

1016. 1. Verbal.

Patrol Leader (Corporal B): Sir, Corporal B reports back with his patrol.

Captain A: I received two messages from you, corporal. What else did you discover?

Corporal B: That was a regiment of infantry, sir, with one battalion thrown out as advance guard. The main body of two battalions went into bivouac at the crossroads and the advance guard formed an outpost line along the big creek two miles south of here.

[Pg 292]

Captain A: Give me an account of your movements.

Corporal B: We followed this main road south to the creek, where we avoided a mounted patrol moving north on the road at 1-45 P. M., and then reconnoitered the valley from a ridge west of the road. We followed the ridge south for half a mile to a point where we could see a road crossing the valley and the main road at right angles, three miles south of here. There we halted, and at 2:20 what seemed to be the point and advance party (about forty men) of an infantry advance guard appeared, marching north up this road, the head at the crossroad. I then sent you message No. 1 by Private Brown.

In fifteen minutes three companies had appeared 600 yards in rear of the advance party, and I could see a heavy, low column of dust about one-half mile further to the rear. Message No. 2 was then sent in by Privates Baker and Johnson, and to avoid several hostile patrols, I drew off further to the northwest.

The advance guard then halted and established an outpost line along the south of the creek, two miles from here. The cloud of dust proved to be two more battalions and a wagon train. These two battalions went into bivouac on opposite sides of this road at the crossroads and sent out strong patrols east and west on the crossroad. Five wagons went forward to the outpost battalion and the reserve built cook fires.

As Private Rush, here, was the only man I had left, we started back, sketching the valley, ridge and positions of the main body and outpost. Here is the sketch, sir. The fields are all cut crops or meadow.

We sighted two foot patrols from the outpost, moving north about a mile from here, one following the road and one further east.

I did not see any of our patrols.

That is all, sir.

2. Written.

Report of Sergeant Wm. James' Patrol of Five Men

Support No. 1,
Outpost of 6th Inf., Near Dixon,
22 Aug. 12, 2-30 to 5 P. M.

The patrol followed the timber along the creek for one mile S. from our outguards and leaving the creek bottom moved $\frac{1}{2}$ mile S. E. to the wooded hill (about 800 ft. high), visible from our lines.

From this hill top the valley to the east (about one mile wide) could be fairly well observed. No signs of the enemy were seen and a message, No. 1, was sent back by Private Russel.

A wagon road runs N. and S. through the valley, bordered by four or five farms with numerous orchards and cleared fields. Both slopes of the valley are heavily wooded.

The patrol then moved S. W., until it struck the macadam pike which runs N. and S., through our lines. Proceeding S. 400 yds. on this pike to a low hill a farmer, on foot, was met. Said he lived one mile further S.; was looking for some loose horses; that four hostile cavalymen, from the east, stopped at his farm at noon, drank some milk, took oats for their horses, inquired the way to Dixon and rode off in that direction within fifteen minutes. He said they were the first hostiles he had seen; that they told nothing about themselves, and they and their horses looked in good condition. Farmer appeared friendly and honest.

[Pg 293]

The patrol then returned to our lines following the pike about two miles. Road is in good condition, low hedges and barbed wire fences, stone culverts and no bridges in the two miles. Bordering country is open and gently rolling farming country and all crops are in. A sketch is attached to this report. None of our patrols was seen.

Respectfully submitted,

Wm. James,
Sergeant, Co. A, 6th Infy.

Problem in Patrol Leading and Patrolling

1017. In studying or solving tactical problems on a map you must remember that unless you carefully work out your own solution to the problem before looking at the given solution, you will practically make no progress.

It is best, if your time permits, to write out your solutions, and when you read over the given solutions, compare the solution of each point with what you thought of that same point when you were solving the problem, and consider why you did just what you did. Without this comparison much of the lasting benefit of the work is lost.

In some of these problems both the problem and solutions are presented in dialogue form so as to give company officers examples of the best method of conducting the indoor instruction of their men in minor tactics. It also gives an example of how to conduct a tactical walk out in the country, simply looking at the ground itself, instead of a map hanging on the wall. The enlarged [Elementary Map](#) referred to in [Par. 954](#), is supposed to be used in this instruction as well as in the war games.

Problem No. 1. (Infantry)

1018. The [Elementary Map](#) (scale 12 inches to the mile) being hung on the wall, about two sergeants and two squads of the company are seated in a semicircle facing it, and the captain is standing beside the map with a pointer (a barrack cleaning rod makes an excellent pointer).

Captain: We will suppose that our company has just reached the village of York. The enemy is reported to be in the vicinity of Boling and Oxford (he points out on the map all places as they are mentioned). We are in the enemy's country.

Corporal James, I call you up at 3 P. M. and give you these orders: "Nothing has been seen of the enemy yet. Our nearest troops are three miles south of here. Take four men from your squad and reconnoiter along this road (County Road) into the valley on the other side of that ridge over there (points to the ridge just beyond the cemetery), and see if you can discover anything about the enemy. Report back here by 5 o'clock. I am sending a patrol out the Valley Pike." Now, Corporal, state just what you would do.

[Pg 294]

Corporal James: I would go to my squad, fall in Privates Amos, Barlow, Sharp and Brown; see that they had full canteens; that their arms were all right; that they were not lame or sick and I

would have them leave their blanket rolls, haversacks and entrenching tools with the company. ([Par. 964.](#))

I would then give these orders ([Par. 963](#)); "We are ordered out on patrol duty. Nothing has been seen of the enemy yet. Our nearest troops are three miles south of here. We are ordered to reconnoiter along this road into the valley on the other side of that ridge, and see if we can discover anything about the enemy. Another patrol is going up the Valley Pike. Reports are to be sent here. In case we are scattered we will meet at the woods on the hill over there (indicates the clump of trees just west of Mills' farm).

"I will go ahead. Amos, follow about fifty yards behind me. Barlow, you and Sharp keep about 100 yards behind Amos, and Brown will follow you at half that distance. All keep on the opposite side of the road from the man ahead of you." ([Par. 968.](#))

Captain: All right, Corporal, now describe what route you will follow.

Corporal James: The patrol will keep to the County Road until the crest of the ridge near the stone wall is reached, when what I see in the valley beyond will decide my route for me.

Captain: How about the woods west of the stone walls?

Corporal James: If I did not see anyone from our patrol on the Valley Pike reconnoitering there, I would give Barlow these orders just after we have examined the cemetery, when the patrol would have temporarily closed up somewhat: "Barlow, take Sharp and examine that little woods over there. Join us at the top of this hill." I would then wave to Brown to close up and would proceed to the hill top.

Captain: Barlow what do you do?

Private Barlow: I would say, "Sharp, out straight across for that woods. I will follow you." I would follow about 100 yards behind him. When he reached the edge of the woods I would signal him to halt by holding up my left hand. After I had closed up to about fifty yards I would say to him, "Go into the woods and keep me in sight." I would walk along the edge of the woods where I could see Sharp and the corporal's patrol on the road at the same time.

Captain: That is all right, Barlow. Corporal, you should have instructed Amos or Brown to keep close watch on Barlow for signals.

Corporal James: I intended to watch him myself.

Captain: No, you would have enough to do keeping on the alert for what was ahead of you. Now describe how you lead the patrol to the top of the hill, by the stone wall.

Corporal James: When I reached the crest I would hold up my hand for the patrol to halt and would cautiously advance and look ahead into the valley. If I saw nothing suspicious I would wave to the men to close up and say, "Amos, go to that high ground about 250 yards over there (indicates the end of the nose made by the 60-foot contour just north of the east end of the stone wall), and look around the country." I would keep Brown behind the crest, watching Barlow's movements.

[Pg 295]

Captain: Now, Corporal, Amos reaches the point you indicated and Barlow and Sharp join you. What do you do?

Corporal James: Can I see the Steel Bridge over Sandy Creek?

Captain: No, it is three-fourths of a mile away and the trees along the road by Smith's hide it. You can see the cut in the road east of the bridge and the Smith house, but the crossroads are hidden by the trees bordering the roads. You see nothing suspicious. It is a clear, sunny afternoon. The roads are dusty and the trees in full foliage. The valley is principally made up of fields of cut hay, corn stubble and meadow land.

Corporal James: Does Private Amos give me any information?

Captain: No, he makes you no signals. You see him sitting behind a bush looking northwest, down the valley.

Corporal James: I would say, "Barlow, head straight across to where that line of trees meets the road (indicates the point where the lane from Mills' farm joins the Chester Pike). Sharp, keep about fifty yards to my right rear." I would follow Barlow at 150 yards and when I had reached the bottom land I would wave to Amos to follow us.

Captain: How about Brown?

Corporal James: I had already given him his orders to follow as rear guard and he should do so without my telling him.

Captain: Amos, what do you do when you see the corporal wave to you?

Private Amos: I would go down the hill and join him.

Captain: No, you could do better than that. You are too far from the corporal for him to signal you to do much of anything except stay there or join him. You should join him, but you should not go straight down to him. You should head so as to strike the Mills' Lane about 100 yards east of the house and then go down the lane, first looking along the stone wall. In this way you save time in reconnoitering the ground near the Mills' farm and protect the patrol against being surprised by an enemy hidden by the line of trees, or the wall along the lane. You are not disobeying your orders but just using common sense in following them out and thinking about what the corporal is trying to do.

Now, Corporal, why didn't you go to the Smith house and find out if the people there had seen anything of the enemy?

Corporal James: You said we were in the enemy's country, sir, so I thought it best to avoid the inhabitants until I found I could not get information in any other way. I intended first to see if I could locate any enemy around here, and if not, to stop at houses on my return. In this way I would be gone before the people could send any information to the enemy about my patrol.

Captain: Barlow reaches the Chester Pike where the Mills' lane leaves it. You are about 150 yards in his rear. Sharp is 50 yards off to your right rear, Amos 100 yards to your left rear and Brown 50 yards behind you. Just as Barlow starts to climb over the barbed wire fence into the Chester Pike you see him drop down on the ground. He signals, "Enemy in sight." Tell me quickly what would you do? [Pg 296]

Corporal James: I would wave my hand for all to lie down, and I would hasten forward, stooping over as I ran, until I was about twenty yards from him, when I would crawl forward to the fence, close by him. Just before I reached him I would ask him what he saw.

Captain: He replies, "There are some hostile foot soldiers coming up this road."

Corporal James: I would crawl forward and look.

Captain: You see three or four men, about 500 yards north of you, coming up the Chester Pike. They are scattered out.

Corporal James: I would say, "Crawl into the lane, keep behind the stone wall, watch those fellows, and work your way to that farm" (indicates the Mills' farm). I would start towards the Mills' farm myself, under cover of the trees along the lane and would wave to the other men to move rapidly west, towards the hills.

Captain: Why didn't you try to hide near where you were and allow the hostile men to pass?

Corporal James: There does not seem to be any place to hide near there that a patrol would not probably examine.

Captain: What is your plan now?

Corporal James: I want to get my patrol up to that small woods near the Mills' farm, but I hardly expect to be able to get them up to that point without their being seen. In any event, I want them well back from the road where they can lie down and not be seen by the enemy when he passes.

Captain: You succeed in collecting your patrol in the woods without their being seen, and you see four foot soldiers in the road at the entrance to the land. One man starts up the lane, the others remaining on the road.

Corporal James: I say, "Brown, go through these woods and hurry straight across to York. You should be able to see the village from the other side of the woods. Report to the captain that a hostile patrol of four foot men is working south up the valley, two miles northeast of York. We will go further north. Repeat what I have told you." ([Par. 979.](#))

Captain: Why didn't you send this message before?

Corporal James: Because we were moving in the same direction that the messenger would have had to go, and, by waiting a very few minutes, I was able to tell whether it was a mere patrol or the point of an advance guard.

Captain: Do you think it correct to send a messenger back with news about a small patrol?

Corporal James: Ordinarily it would be wrong, but as nothing has been seen of the enemy until now, this first news is important because it proves to the Captain that the enemy really is in this neighborhood, which it seems to me is a very important thing for him to know and what my mission required me to do. ([Par. 981.](#)) [Pg 297]

Captain: What are you going to do now, Corporal?

Corporal James: We have traveled about two miles and stopped frequently, so it must be about

4 o'clock. It is one and one-third miles back to York, where I should arrive about 5 o'clock. It would take me twenty-five minutes to go from here to York, so I have about thirty-five minutes left before 5 o'clock. This will permit me to go forward another mile and still be able to reach York on time. It is two-thirds of a mile to the Mason farm, and if the hostile patrol appears to be going on, I will start for that point. Did anyone at the Mills' farm see us?

Captain: No, but tell me first why you do not go along this high ground that overlooks the valley?

Corporal James: Because our patrol that started out the Valley Pike is probably near Twin Hills and I want to cover other country. The orchard at Mason's would obstruct my view from the hills.

Captain: The hostile patrol goes on south. Describe briefly your next movements.

Corporal James: I lead my patrol over to Mason's and, concealing two of the men so that both roads and the house can be watched, I take one man and reconnoiter around the farm yard and go up to the house to question the inhabitants. ([Par. 996.](#))

Captain: You find one woman there who says some other soldiers, on foot, passed there a few minutes ago, marching south. She gives you no other information about the enemy or country.

Corporal James: I would send Amos over to see how deep and wide Sandy Creek is ([Par. 1001.](#)) When he returned I would take the patrol over to Twin Hills, follow the ridge south to the stone wall on the County Road, watching the valley for signs of the hostile patrol, and follow the road back to York; then make my report to the Captain, telling him where I had gone, all I had seen, including a description of the country. If I had not been hurried, I would have made a sketch of the valley. I can make a rough one after I get in. ([Par. 1015.](#))

Captain: Suppose on your way back you saw hostile troops appearing on the County Road, marching west over Sandy Ridge. Would you stay out longer or would you consider that you should reach Oxford by 5 o'clock?

Corporal James: I would send a message back at once, and remain out long enough to find out the strength and probable intention of the new enemy.

Captain (to one platoon of his troop of cavalry): We will suppose that this troop has just (9 A. M.) arrived in Boling ([Elementary Map](#)) on a clear, dry, summer day. The enemy is supposed to be near Salem and we have seen several of his patrols this morning on our march south to Boling. Sergeant Allen, I call you up and give you these instructions: "Take Corporal Burt's squad (eight men) and reconnoiter south by this road (indicates the Boling-Morey house road) to Salem. I will take the troop straight south to Salem and you will join it there about 10:15. It is four and one-half miles to Salem. Start at once." (You have no map.)

[Pg 298]

Sergeant Allen: I would like to know just what the Captain wishes my patrol to do. ([Par. 965.](#))

Captain: We will suppose that this is one of the many occasions in actual campaign where things must be done quickly. Where there is no time for detailed orders. You know that the troop has been marching south towards Salem where the enemy is supposed to be. You also know we have seen several of his patrols. I have told you what the troop is going to do, and from all this you should be able to decide what your mission is in this case. We will, therefore, consider that there is no time to give you more detailed orders, and you have to decide for yourself. Of course, if you had failed to hear just what I said, then, in spite of the necessity for haste, I would repeat my instructions to you. ([Par. 963.](#))

Sergeant Allen: I would ride over to Corporal Burt's squad and lead it out of the column to the road leading to the Morey house, and say, "The troop is going on straight south to Salem, four and one-half miles away. This squad will reconnoiter south to Salem by this road, joining the troop there about 10:15. In case we become separated, make for Salem. Corporal, take Brown and form the point. I will follow with the squad about 300 yards in rear. Regulate your gait on me after you get your distance. Move out now at a trot." ([Par. 963.](#))

After Corporal Burt had gotten 150 yards out I would say, "Carter, move out as connecting file." I would then say, "Downs, you will follow about 150 yards behind us as rear guard." When Carter had gone 150 yards down the road I would order, "**1. Forward; 2. Trot; 3. March,**" and ride off at the head of the four remaining men (in column of twos.) ([Par. 968.](#))

Captain: Sergeant, tell me briefly what is your estimate of the situation—that is, what sort of a proposition you have before you and how you have decided to handle it.

Sergeant Allen: As the enemy is supposed to be near Salem and we have already seen his patrols, I expect to encounter more patrols and may meet a strong body of the enemy, on my way to Salem. As I have no map, I cannot tell anything about the road, except that it is about four and one-half miles by the direct road the troop will follow, therefore my route will be somewhat longer. I have been given an hour and fifteen minutes in which to make the trip, so, if I move at a trot along the safer portions of the road. I will have time to proceed very slowly and cautiously along the dangerous portions. My patrol will be stretched out about 500 yards on the road, which should make it difficult for the enemy to surprise us and yet should permit my controlling the

movements of the men. ([Par. 968.](#))

I consider that my mission is to start out on this road and find my way around to Salem in about an hour and, particularly, to get word across to the Captain on the other road of anything of importance about the enemy that I may learn.

Captain: Very well. When you reach the cut in the road across the south nose of Hill 38, your point has almost reached the Morey house. Do you make any change in your patrol? [Pg 299]

Sergeant Allen: I order, "**1. Walk, 2. MARCH,**" and watch to see if the connecting file observes the change in gait and comes to a walk.

Captain: Suppose he does not come to a walk?

Sergeant Allen: I would say, "Smith, gallop ahead and tell Carter to walk and to keep more on the alert."

Captain: Corporal Burt, you reach the road fork at Morey's. What do you do?

Corporal Burt: I say, "Brown, wait here until Carter is close enough to see which way you go and then trot up to me." I would walk on down the road.

Captain: Wouldn't you make any inspection of the Morey house?

Corporal Burt: Not unless I saw something suspicious from the road. I would expect the main body of the patrol to do that.

Captain: Don't you make any change on account of the woods you are passing?

Corporal Burt: No, sir. It has very heavy underbrush and we would lose valuable time trying to search through it. A large force of the enemy would hardly hide in such a place.

Captain: Sergeant Allen, you reach the road fork. What do you do?

Sergeant Allen: I would have two men go into the Morey house to question anyone they found there. I would order one of the other two men to trot up (north) that road 200 yards and wait until I signaled to him to return. With the other man I would await the result of the inspection of the Morey house. Corporal Burt should have gone ahead without orders to the cut in the road across Long Ridge, leaving Brown half way between us. ([Pars. 987](#) to 996.)

Captain: You find no one at the Morey house.

Sergeant Allen: I would signal the man to the north to come in. I would then order two men to "find a gate in the fence and trot up on that hill (indicating Long Ridge), and look around the country and join me down this road." ([Par. 968.](#)) I would then start south at a walk, halting at the cut to await the result of the inspection on the country from the hill.

Captain: Foster, you and Lacey are the two men sent up on Long Ridge. When you reach the hilltop you see four hostile cavalymen trotting north on the Valley Pike, across the railroad track.

Private Foster: I signal like this (enemy in sight), and wait to see if they go on north. ([Par. 978.](#)) Do I see anything else behind or ahead of them?

Captain: You see no other signs of the enemy on any road. Everything looks quiet. The hostile cavalymen pass the Baker house and continue north.

Private Foster: I would then take Lacey, trot down the ridge to Sergeant Allen, keeping below the crest and report, "Sergeant, We saw four hostile mounted men trotting north on the road about three-quarters of a mile over there (pointing), and they kept on north, across that road (pointing to the Brown-Baker-Oxford road). There was nothing else in sight." I would then tell him what the country to the south looked like, if he wanted to know. [Pg 300]

Captain: Sergeant Allen, what do you do now?

Sergeant Allen: I would continue toward the Brown house at a trot. I would send no message to you as you already know there are hostile patrols about and therefore this information would be of little or no importance to you. ([Par. 981.](#))

Captain: You arrive at Brown's house.

Sergeant Allen: I would send two men in to question the people and I would continue on at a walk. I would not send any one up the road towards Oxford as Foster has already seen that road.

Captain: You should have sent a man several hundred yards out the Farm Lane. ([Par. 989.](#)) If he moved at a trot it would only have taken a very short time. Continue to describe your movements.

Sergeant Allen: I would halt at the railroad track until I saw my two men coming on from the Brown house. I would then direct the other two men who were with me to go through the first opening in the fence to the west and ride south along that ridge (62—Lone Hill—Twin Hills' ridge) until I signaled them to rejoin. I would tell them to look out for our troop over to the east. If there were a great many fences I would not send them out until we were opposite the southern edge of that woods ahead of us. There I would send them to the high ground to look over the country, and return at once.

Captain: There are a great many fences west of the road and practically none east of the road to Sandy Creek. Just as you arrive opposite the southern edge of those woods and are giving orders for the two men to ride up the hill, you hear firing in the direction of Bald Knob. In the road at the foot of the south slope of Bald Knob, where the trail to the quarry starts off, you can see quite a clump of horses. You see nothing to the west of your position or towards Mason's. What do you do?

Sergeant Allen: I signal "RALLY" to Carter and Downs. If there is a gate nearby I lead my men through it. If not, I have them cut or break an opening in the fence and ride towards the railroad fill at a fast trot, having one man gallop ahead as point.

When we reach the fill, the point having first looked beyond it, I order, "**DISMOUNT**. Lacey, hold the horses. **1. As skirmishers along that fill, 2. MARCH.**" When Corporal Burt, Brown, Carter and Downs come up Lacey takes their horses and they join the line of skirmishers. Captain, what do I see from the fill?

Captain: There appear to be about twenty or thirty horses in the group. The firing seems to come from the cut in the road just north of the horses and from the clump of trees by the Quarry. You can also hear firing from a point further north on the road, apparently your troop replying to the fire from Bald Knob. You see nothing in the road south of the horses as far as Hill 42, which obstructs your view. What action do you take?

Sergeant Allen: I order, "**AT THE FEET OF THOSE HORSES. RANGE, 850. CLIP FIRE.**"

[Pg 301]

Captain: What is your object in doing as you have done?

Sergeant Allen: I know the captain intended to go to Salem with the troop. From the fact that he is replying to the hostile fire I judge he still wishes to push south. I was ordered to reconnoiter along this road, but now a situation has arisen where the troop is being prevented or delayed in doing what was desired and I am in what appears to be a very favorable position from which to give assistance to the troop and enable them to push ahead. I am practically in rear of the enemy and within effective range of their lead horses. I therefore think my mission has at least temporarily changed and I should try and cause the twenty or thirty hostile troopers to draw off ([Par. 1011](#)). Besides, I think it is my business to find out what the strength of this enemy is and whether or not he has reinforcements coming up from Salem, and send this information to the captain. From my position I can still watch the Chester Pike.

Captain: After you have emptied your clips you see the enemy running down out of the cut and from among the trees mount their horses and gallop south. What do you do?

Sergeant Allen: I would send Foster across the creek above the trestle (south of trestle), to ride across to that road (pointing towards the cut on Bald Hill) and tell the captain, who is near there, that about thirty men were on the hill and they have galloped south, and that I am continuing towards Salem. I would have Foster repeat the message that I gave him. I would then trot back to the Chester Pike and south to Mason's, taking up our old formation.

Captain: You see nothing unusual at Mason's and continue south until you reach the cross roads by the Smith farm. Corporal Burt and Private Brown are near the stone bridge south of Smith's; Private Carter is half way between you and Corporal Burt; and Private Downs is 100 yards north of Smith's. You have three men with you. What do you do?

Sergeant Allen: What time is it now?

Captain: It is now 9:45 A. M.

Sergeant Allen: I would say, "Lacey, take Jackson and gallop as far as that cut in the road (points east) and see if you can locate the enemy or our troop in the valley beyond. I will wave my hat over my head when I want you to return." I would then say to Private Moore, "Gallop down to Corporal Burt and tell him to fall back in this direction 100 yards, and then you return here bringing the other two men with you." I would then await the result of Private Lacey's reconnaissance, sending Carter to the turn in the road 200 yards west of the cross roads.

Captain: Lacey, what do you do?

Private Lacey: I order Jackson, "Follow 75 yards behind me and watch for signals from Sergeant Allen," and I then gallop across the steel bridge and half way up the hill. I then move cautiously up to the cut and, if the fences permit, I ride up on the side of the cut, dismounting just before reaching the crest of the ridge, and walk forward until I can see into the valley beyond.

[Pg 302]

Captain: You see no signs of the enemy in the valley, but you see your own troop on the road by the Gibbs farm with a squad in advance in the road on Hill 42.

Private Lacey: I look towards Sergeant Allen to see if he is signaling. I make no signals.

Captain: What do you do, Sergeant?

Sergeant Allen: I wave my hat for Private Lacey to return. I wave to Private Downs to join me and when Private Lacey arrives I signal "ASSEMBLE" to Corporal Burt and then say, "Lacey, join Corporal Burt and tell him to follow me as rear guard. Martin, join Carter and tell him to trot west. We will follow. You stay with him." After he got started I would order, "Follow me. **1. Trot; 2. MARCH.**"

Captain: When Private Carter reaches the crest of the ridge about one-half mile west of Smith's he signals, "Enemy in sight in large numbers," and he remains in the road with Martin fifty yards in rear. ([Par. 978.](#))

Sergeant Allen: I order, "**1. Walk; 2. MARCH. 1. Squad; 2. HALT,**" and gallop up to Private Carter, dismount just before reaching the crest, give my horse up to Private Martin, and run forward.

Captain: Carter points out what appears to be a troop of cavalry standing in the road leading north out of York, just on the edge of the town. You see about four mounted men 200 yards out of York on your road, halted, and about the same number on the Valley Pike near where it crosses the first stream north of York. What do you do?

Sergeant Allen: I wait about three minutes to see if they are going to move.

Captain: They remain halted, the men at York appear to be dismounted.

Sergeant Allen: I write the following message:

Hill $\frac{1}{2}$ mile N. E. of York,
10 A. M.

Captain X:

A hostile troop of cavalry is standing in road at YORK (west of SALEM) with squads halted on N. and N. E. roads from YORK. Nothing else seen. Will remain in observation for the present.

Allen,
Sgt.

I would give the message to Martin, who had previously brought my horse up close in rear of the crest, and would say to him, "Take this message to the captain, straight across to the road the troop is on, and turn south towards Salem if you do not see them at first. Take Lacey with you. Tell him what you have seen. He knows where the troop is." I would have Carter hold my horse, and watch the remainder of the patrol for signals, while I observed the enemy.

Captain: At the end of five minutes the hostile troop trots north on the Valley Pike, the patrol on your road rides across to the Valley Pike and follows the troop.

Sergeant Allen: I would wait until the troops had crossed the creek north of York and would then face my patrol east and trot to the cross roads at Smith's, turn south and continue to Salem, sending one man to ride up on Sandy Ridge, keeping the patrol in sight.

[Pg 303]

Captain: We have carried out the problem far enough. It furnishes a good example of the varying situations a patrol leader has to meet. Good judgment or common sense must be used in deciding on the proper course to follow. You must always think of what your chief is trying to do and then act in the way you think will best help him to accomplish his object. If you have carefully decided just what mission you have been given to accomplish, you cannot easily go wrong. In handling a mounted patrol you must remember that if the men become widely separated in strange country, or even in country they are fairly familiar with, they are most apt to lose all contact with each other or become lost themselves.

Problem No. 2. (Infantry)

1019. Captain (to one platoon of his company): We will suppose it is about half an hour before dawn. One platoon of the company is deployed as skirmishers, facing north, in the cut where the County Road crosses Sandy Ridge. It is the extreme right of a line of battle extending west along the line of the County Road. The fight was not commenced. This platoon is resting in a wheat field between the railroad and the foot of the slope of Sandy Ridge, 200 yards south of the County Road. Sergeant Allen, I call you up and give you these instructions: "The enemy's line is off in that direction (pointing northwest). Take six men and work north along the railroad until it is light enough to see; then locate the hostile line and keep me informed of their movements. I will be in this vicinity. You have a compass. Start at once." Describe briefly the formation of your

patrol while it is moving in the dark.

Sergeant Allen: One man will lead. A second man will follow about fifteen yards in rear of him. I will follow the second man at the same distance with three more men, and the last man will be about twenty yards in rear of me. All will have bayonets fixed, loaded and pieces locked. One short, low whistle will mean, **Halt**, two short whistles will mean, **Forward**, and the word "Sandy" will be the countersign by which we can identify each other.

Captain: Very well. We will suppose that you reach the steel trestle over Sandy Creek just at dawn and have met no opposition and heard nothing of the enemy. On either side of Sandy Creek are fields of standing corn about six feet tall. In the present dim light you can only see a few hundred yards off.

Sergeant Allen: The patrol being halted I would walk forward to the leading man (Brown) and say, "Brown, take Carter and form the point for the patrol, continuing along this railroad. We will follow about 150 yards in rear." I would then rejoin the main body of the patrol and order the man in rear to follow about 75 yards in rear of us. When the point had gained its distance I would move forward with the main body, ordering one man to move along the creek bank (west bank), keeping abreast of us until I signaled to him to come in.

Captain: Just as you reach the northern end of the railroad fill your point halts and you detect some movement in the road to the west of you. It is rapidly growing lighter. [Pg 304]

Sergeant Allen: I would move the main body by the left flank into the corn, signaling to the man following the creek to rejoin, and for the rear guard to move off the track also. I would expect Brown to do the same, even before he saw what we had done. I would then close up on the point until I could see it and, halting all the patrol, I would order Foster to take Lacey and work over towards the road to see what is there and to report back to me immediately.

Captain: In a few minutes Foster returns and reports, "The enemy is moving south in the road and in the field beyond, in line of squads or sections. A hostile patrol is moving southeast across the field behind us. We were not seen."

(Note: This situation could well have been led up to by requiring Private Foster to explain how he conducted his reconnaissance and having him formulate his report on the situation as given.)

Sergeant Allen: I would then work my patrol closer to the road, keeping Foster out on that flank, and prepare to follow south in rear of the hostile movement.

Captain: The information you have gained is so important that you should have sent a man back to me with a verbal message, particularly as you are in a very dangerous position, and may not be able to send a message later. While you have not definitely located the left of the enemy's line, you have apparently discovered what appears to be a movement of troops forward to form the left of the attacking line. Your action in turning south to follow the troops just reported, is proper, as you now know you are partly in rear of the hostile movement and must go south to locate the hostile flank that your mission requires you to report on.

You men must picture in your minds the appearance of the country the sergeant is operating through. His patrol is now in a field of high standing corn. Unless you are looking down between the regular rows of corn you can only see a few yards ahead of you. The road has a wire fence and is bordered by a fairly heavy growth of high weeds and bushes. The ground is dry and dusty. Sergeant, how do you conduct your movement south?

Sergeant Allen: As my patrol is now in a very dangerous neighborhood and very liable to be caught between two hostile lines, with a deep creek between our present position and our platoon, I think it best to move cautiously southeast until I reach the creek bank (I cannot see it from where I now am), and then follow the creek south. I think I am very apt to find the enemy's left resting on this creek. Besides, if I do not soon locate the enemy, I can hold the main body of my patrol close to the creek and send scouts in towards the road to search for the enemy. It will also be much easier to send information back to the platoon from the creek bank, as a messenger can ford it and head southeast until he strikes the railroad and then follow that straight back to our starting point. It would thus be very difficult for him to get lost.

Captain: You move southeast and strike the creek bank just south of the railroad trestle. You now hear artillery fire off to the west and a rifle fire to the southwest which gradually increases in volume. You see a high cloud of dust hanging over the road on the hill west of Mason's and south of this road on the north slope of the northern-most knoll of the Twin Hills, you can occasionally see the flash of a gun, artillery being discharged. There seems to be no rifle firing directly in your front. [Pg 305]

Sergeant Allen: I hurriedly write the following message:

At Ry. trestle 1 mi. N. of Platoon,
5:15 A. M.

Captain X:

Can see arty. firing from position on N. slope of knoll on high ridge to W. of me, and $\frac{1}{4}$ mi. S. of E. and W. road. Hostile line is S. of me. Have not located it. Will move S.

Allen,
Sgt. ([Par. 974.](#))

I hand this to Private Smith and say to him. "Carry this quickly to the captain. Follow the railroad back until you cross a wagon road. Our platoon should be to the west of the track just beyond the road." I also read the message to Smith and point out the hostile artillery. I have considered that I sent a message before telling about the hostile advance.

I then continue south, moving slowly and with great caution. I instruct the remaining four men that in case we are surprised to try to cross the creek and follow the railroad back to the platoon.

Captain: Your information about the hostile artillery position was important and should have been sent in, provided you think your description of the hostile position was sufficiently clear to be understood by an observer within your own lines.

There is some question as to the advisability of your remaining on the west bank of the creek. Still you would not be able to tell from where you were what direction the creek took, so you probably would remain on the west bank for the present.

You continue south for about 150 yards and your leading man halts, comes back to you, and reports that the corn ahead is broken and trampled, showing it has been passed over by foot troops. About the same time you hear rifle fire to your immediate front. It sounds very close.

Sergeant Allen: I say, "Cross this creek at once," and when we reach the other bank and the patrol forms again, we move slowly south, all the men keeping away from the creek bank, except myself, and I march opposite the two men constituting the main body.

Captain: About this time you detect a movement in the corn across the creek in rear of the place you have just left. You think it is a body of troops moving south. The firing in front seems to be delivered from a point about two or three hundred yards south of you and you can hear heavy firing from off in the direction of your company, a few bullets passing overhead. There are scattered trees along the creek and some bushes close to the edge.

Sergeant Allen: I would conceal myself close to the bank, the patrol being back, out of sight from the opposite bank, and await developments.

[Pg 306]

Captain: Sergeant, your patrol is in a dangerous position. The enemy will very likely have a patrol or detachment in rear and beyond his flank. This patrol would probably cross the railroad trestle and take you in rear. You should have given the last men in your patrol particular instructions to watch the railroad to the north. It would have been better if you had sent one man over to the railroad, which is only a short distance away, and had him look up and down the track and also make a hurried survey of the country from an elevated position on the hill.

I also think it would be better not to await developments where you now are, but to push south and make sure of the position of the left of the enemy's firing line, later you can devote more time to the movements in rear of the first line. You are taking too many chances in remaining where you are. I do not mean that you should leave merely because you might have some of your men killed or captured, but because if this did occur you would probably not be able to accomplish your mission. Later you may have to run a big chance of sacrificing several of your men, in order to get the desired information, which would be entirely justifiable. Tell me how your men are arranged and what your next movement would be.

Sergeant Allen: I have four men left, I am close to the stream's bank, under cover; two men are about 25 yards further away from the stream; Private Brown is up stream as far off as he can get and still see the other two men, and Private Foster is down stream the same distance. Both Brown and Foster are well back from the stream. The two men in the middle, the main body of the patrol, make their movements conform to mine, and Brown and Foster regulate their movements on the main body. I will move south until I can locate the enemy's advance line.

Captain: When you are opposite the Mason house, Brown comes back to you, having signaled halt, and reports he can see the enemy's firing line about 100 yards ahead on the other side of the stream, and that a small detachment is crossing the stream just beyond where he was. What do you do?

Sergeant Allen: I creep forward with Brown to verify his report. The remainder of the patrol remains in place.

Captain: You find everything as Brown reported. You see that the firing line extends along the southern edge of the cornfield, facing an uncultivated field covered with grass and frequent patches of weeds two or three feet high. You cannot determine how strong the line is, but a heavy fire is being delivered. You cannot see the detachment that crossed the creek south of you because of the standing corn.

$\frac{5}{6}$ mi. N. of Platoon,
5:32 A. M.

Captain X:

Enemy's left rests on creek $\frac{3}{4}$ mile to your front, along S. edge of cornfield. Creek is 5 ft. deep by 60 ft. wide. Hostile patrols have crossed the creek. Will watch their rear.

Allen,
Sgt.

I give this to Private James and say, "Go over to the railroad (pointing), then turn to your right and follow the track until you cross a wagon road. Our platoon is just beyond that, on this side of the track. Give this message to the captain. Hurry."

Captain: You should have either read the message to James or had him read it. You should also have cautioned him to watch out for that hostile detachment. It might be better to send another man off with a duplicate of the message, as there is quite a chance that James may not get through and the message is all-important. James, you get back to the wagon road here (pointing) and find yourself in the right of your battle line, but cannot locate me or the company right away.

Private James: I would show the note to the first officer I saw in any event, and in this case, I would turn it over to the officer who appeared to be in command of the battalion or regiment on the right of the line, telling him what company the patrol belonged to, when we went out, etc.

Captain: What do you do, sergeant?

Sergeant Allen: I start to move north a short distance in order to find out what reënforcements are in rear of the hostile line.

Captain: After you have moved about 75 yards you are suddenly fired into from across the creek, and at the same time from the direction of the railroad trestle. Your men break and run east through the corn and you follow, but lose sight of them. When you cross the railroad fill you are fired on from the direction of the bridge. You finally stop behind the railroad fill on the quarry switch, where two of your men join you.

Sergeant Allen: I would start south to rejoin the company and report.

Captain: That would be a mistake. It would require a long time for a second patrol to make its way out over unknown ground, filled with hostile patrols, to a point where they could observe anything in rear of the hostile flank. You are now fairly familiar with the ground, you also know about where the hostile patrols are and you have two men remaining. After a brief rest in some concealed place nearby, you should start out again to make an effort to determine the strength of the troops in rear of the hostile flank near you, or at least remain out where you could keep a sharp lookout for any attempted turning movement by the enemy. Should anything important be observed you can send back a message and two of you remain to observe the next developments before returning. The information you might send back and the additional information you might carry back, would possibly enable your own force to avoid a serious reverse or obtain a decided victory.

[Pg 308]

Your work would be very hazardous, but it is necessary, and while possibly resulting in loss of one or two of your men, it might prevent the loss of hundreds in your main force.

CHAPTER V

[Pg 309]

THE SERVICE OF SECURITY

(Based on the Field Service Regulations.)

General Principles

1020. The Service of Security embraces all those measures taken by a military force to protect itself against surprise, annoyance or observation by the enemy. On the march, that portion of a command thrown out to provide this security is called an advance, flank or rear guard, depending on whether it is in front, to the flank or in rear of the main command; in camp or bivouac, it is called the outpost.

The principal duties of these bodies being much the same, their general formations are also very similar. There is (1) the cavalry covering the front; next (2) a group (4 men to a platoon) or line of groups in observation; then (3) the support, or line of supports, whose duty is to furnish the men for the observation groups and check an enemy's attempt to advance until reinforcements can

arrive; still farther in rear is (4) the reserve.

In small commands of an infantry regiment or less there usually will not be any cavalry to cover the front, and the reserve is generally omitted. Even the support may be omitted and the observation group or line of groups be charged with checking the enemy, in addition to its regular duties of observation. But whatever the technical designation of these subdivisions, the rearmost one is always in fact a reserve. For example, if the command is so small that the subdivision formally designated as the reserve is omitted, the rear element (squad or platoon or company, etc.) is used as a reserve. As this text deals principally with small commands and only those larger than a regiment usually have the subdivision termed the reserve, this distinction between the element in the Field Service Regulations called the reserve and the actual reserve, must be thoroughly understood.

The arrangements or formations of all detachments thrown out from the main force to provide security against the enemy, are very flexible, varying with every military situation and every different kind of country. The commander of such a detachment must, therefore, avoid blindly arranging his men according to some fixed plan and at certain fixed distances. Acquire a general understanding of the principles of the service of security and then with these principles as a foundation use common sense in disposing troops for this duty.

ADVANCE GUARD

1021. Definition and Duties. An advance guard is a detachment of a marching column thrown out in advance to protect the main column from being surprised and to prevent its march from being delayed or interrupted. (The latter duty is generally forgotten and many irritating, short halts result, which wear out or greatly fatigue the main body, the strength of which the advance guard is supposed to conserve.)

[Pg 310]

In detail the duties of the advance guard are:

1. To guard against surprise and furnish information by reconnoitering to the front and flanks.
2. To push back small parties of the enemy and prevent their observing, firing upon or delaying the main body.
3. To check the enemy's advance in force long enough to permit the main body to prepare for action.
4. When the enemy is met on the defenses, seize a good position and locate his lines, care being taken not to bring on a general engagement unless the advance guard commander is authorized to do so.
5. To remove obstacles, repair the road, and favor in every way possible the steady march of the column.

1022. Strength: The strength of the advance guard varies from one-ninth to one-third of the total command. The larger the force the larger in proportion is the advance guard, for a larger command takes relatively longer to prepare for action than a small one. For example, a company of 100 men would ordinarily have an advance guard of from one to two squads, as the company could deploy as skirmishers in a few seconds. On the other hand, a division of 20,000 men would ordinarily have an advance guard of about 4,500 men, all told, as it would require several hours for a division to deploy and the advance guard must be strong enough to make a stubborn fight.

1023. Composition. The advance guard is principally composed of infantry, preceded if possible, by cavalry well to the front. When there is only infantry, much more patrolling is required of the front troops than when cavalry (called "Advance cavalry") is out in advance. This book does not deal with large advance guards containing artillery and engineers. Machine guns, however, will be frequently used in small advance guards to hold bridges, defiles, etc.

1024. Distance From Main Body. The distance at which the advance guard precedes the main body or the main body follows the advance guard depends on the military situation and the ground. It should always be great enough to allow the main body time to deploy before it can be seriously engaged. For instance the advance guard of a company, say 1 squad, should be 350 to 500 yards in advance of the company. The distance from the leading man back to the principal group of the squad should generally be at least 150 yards. This, added to the distance back to the main body or company, makes a distance of from 500 to 650 yards from the leading man to the head of the main body.

Examples:

Command.	Advance Guard.	Distance (yds.).
Patrol of 1 squad	2 men	100 to 300
Section of 3 squads	4 men	200 to 400
Inf. platoon of 50 men	1 squad	300 to 450
Cav. platoon of 20 men	4 men	300 to 450
Inf. company of 108 men	1 to 2 squads	350 to 500

Cav. troop of 86 men	1/2 platoon	450 to 600
Inf. battalion	1/2 to 1 company	500 to 700
Cav. squadron	1/2 to 1 troop	600 to 800

These are not furnished as fixed numbers and distances, but are merely to give the student an approximate, concrete idea.

1025. Connecting Files. It should be remembered that between the advance guard and the main body, and between the several groups into which the advance guard is subdivided, connecting files are placed so as to furnish a means of communicating, generally by signals, between the elements (groups) of the column. There should be a connecting file for at least ever, 300 yards. For example, suppose the advance guard of a platoon is 300 yards in front of the main body. In ordinary rolling country, not heavily wooded, a connecting file would be placed half way between the two elements—150 yards from each one.

It is generally wiser to use two men together instead of one, because this leaves one man free to watch for signals from the front while the other watches the main body. However, in very small commands like a company, this is not practicable, as the extra man could not be spared.

FORMATION OF ADVANCE GUARDS.

1026. Subdivisions. The advance guard of a large force like a brigade or division is subdivided into a number of groups or elements, gradually increasing in size from front to rear. The reason for this is that, as has already been explained, a larger group or force requires longer to deploy or prepare to fight than a smaller one, therefore the small subdivisions are placed in front where they can quickly deploy and hold the enemy temporarily in check while the larger elements in rear are deploying. The number of these subdivisions decreases as the strength of the advance guard decreases, until we find the advance guard of a company consists of one or two squads, which naturally cannot be subdivided into more than two groups; and the advance guard of a squad composed of two men, which admits of no subdivision.

		Distance to next element in rear.
Advance Cavalry		1 to 5 miles
Support	Advance party (furnishes patrols) Support proper	Point 150 to 300 yds.
		Advance party proper 300 to 600 yds.
		400 to 800 yds.
Reserve (usually omitted in small commands)		500 yds. to 1 mile

The distances vary principally with the size of the command—slightly with the character of the country.

The advance cavalry is that part of the advance guard going in front of all the foot troops. It is generally one to five miles in advance of the infantry of the advance guard, reconnoitering at least far enough to the front and flanks to guard the column against surprise by artillery fire—4,500 yards.

1027. Support. (a) The support constitutes the principal element or group of all advance guards. It follows the advance cavalry, when there is any, and leads the advance guard when there is no cavalry. The support of a large command is subdivided within itself in much the same manner as the advance guard as a whole is subdivided. It varies in strength from one-fourth to one-half of the advance guard.

1028. (b) Advance Party. As the support moves out it sends forward an advance party several hundred yards, the distance varying with the nature of the country and size of the command. For example, the advance party of a support of one company of 108 men, would ordinarily be composed of one section of three squads, and would march about 300 yards in advance of the company in open country, and about 200 yards in wooded country.

The advance party sends out the patrols to the front and flanks to guard the main body of the support from surprise by effective rifle fire. Patrols are only sent out to the flanks to examine points that cannot be observed from the road. As a rule they will have to rejoin some portion of the column in rear of the advance party. As the advance party becomes depleted in strength in this manner, fresh men are sent forward from the main body of the support to replace those who have fallen behind while patrolling. When there is advance cavalry, much less patrolling is required of the infantry.

(c) The point is a patrol sent forward by the advance party 150 to 300 yards. When the advance party is large enough the point should ordinarily consist of a complete squad, commanded by an officer or experienced noncommissioned officer. It is merely a patrol in front of the column and takes the formation described for patrols.

(d) The commander of the support ordinarily marches with the advance party. He should have a

map and control of the guide, if any is present. He sees that the proper road is followed; that guides are left in towns and at crossroads; that bridges, roads, etc., are repaired promptly so as not to delay the march of the column and that information of the enemy is promptly sent back to the advance guard commander; he verifies the correctness of this information, if possible.

1029. (a) A thorough understanding of the arrangement of the support and the duties of the leaders of its subdivisions—point, flank patrols, advance party and main body (of the support)—is of the greatest importance to a noncommissioned officer. For example, the ignorance of one noncommissioned officer leading the advance party of a column of troops six miles long can cause the entire column to be delayed. If he halts because a few shots are fired at his men, and conducts a careful reconnaissance before attacking (instead of pushing right in on the enemy, forcing him to fall back quickly, if a weak detachment; or, to disclose his strength, if strong), the entire column, six miles long, is halted, the march interrupted, valuable time lost, and what is more important, the men irritated and tired out.

(b) The leader of the point must understand that as the principal duty of an advance guard is to secure the safe and uninterrupted march of the main body, he is the first man to discharge this duty. If, for example, his squad receives a volley of shots from some point to the front, he cannot take the time and precautions the commander of a large body would take to reconnoiter the enemy's position, determine something about his strength, etc., before risking an attack. If he did he would not be securing the uninterrupted march of the main body. He has to deploy instantly and press the enemy hard until the hostile opposition disappears or the advance party comes up and its commander takes charge. The point will lose men in this way, but it is necessary, for otherwise one small combat patrol could delay the march time after time.

[Pg 313]

(c) The same problem must be met in much the same manner by the leader of the advance party. In this case there is more time to think, as the point, being in advance, will have begun the fight before the advance party arrives; but the leader of the advance party must use his men freely and quickly to force the enemy to "show his hand," thus preventing small harassing or combat detachments from delaying the march.

(d) As the subdivisions of the advance guard become larger their leaders act with increasing caution, for as soon as it develops that the enemy in front is really present in some strength, then a halt becomes obligatory and a careful reconnaissance necessary.

(e) The leader of every subdivision must always start a reconnaissance the instant the enemy develops. He may, as in the case of the point, only send one man around to discover the enemy's strength; or, if the leader of the main body of the support, he may send an entire squad. In almost every case the instant he has given his orders for deploying and firing at or rushing the enemy, he sends out his man or men to work around to a position permitting a view of the hostile force. Every noncommissioned officer should impress this on his memory so that he will not forget it in the excitement of a sudden engagement.

(f) No attempt should be made to subdivide the advance guard of a small force into all the elements previously described. For example, the advance guard of a squad is simply a point of one or two men; the advance guard of a company is usually no more than a squad acting as a point, the squad actually having several men from 100 to 150 yards in advance, who really constitute a point for the squad; the advance guard of a battalion would usually consist of a company or less distributed as an advance party proper and a point. The advance guard of a regiment would have no reserve—if, for example, a battalion were used as the advance guard of a regiment, there would be only a support, which would be distributed about as follows: A support proper of about three companies and an advance party (point included) of about one company.

[Pg 314]

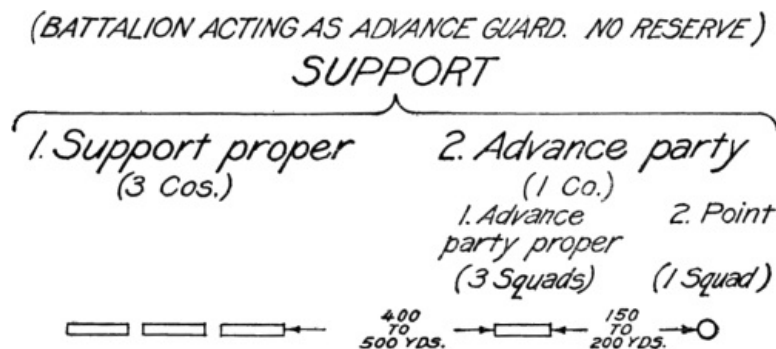

Fig. 1

1030. Reserve. An advance guard large enough to have a reserve would be distributed as follows:

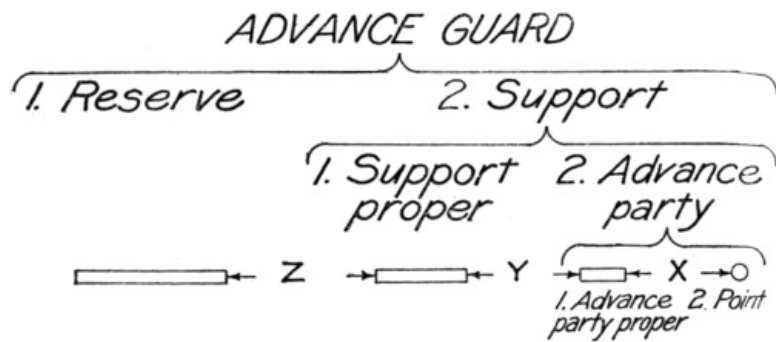

Fig. 2

The distance Z would be greater than Y and Y would be greater than X. For example, a regiment acting as the advance guard of a brigade would, under ordinary conditions, be distributed about as follows:

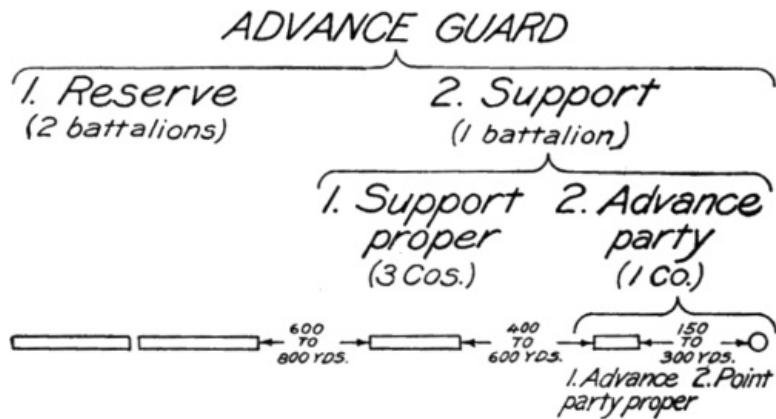

Fig. 3

As only large commands have a reserve, which would always be commanded by an officer, noncommissioned officers need not give this much consideration, but it must be understood that while this fourth subdivision of the advance guard is the only one officially termed reserve, the last subdivision of any advance guard actually is a reserve, no matter what its official designation.

The advance guard of a cavalry command adopts formations similar to those described above, except that the distances are increased because of the rapidity with which the command can close up or deploy. An advance party with a few patrols is usually enough for a squadron, and precedes it from 600 to 1,000 yards.

[Pg 315]

1031. Reconnaissance. In reconnaissance the patrols are, as a rule, small (from two to six men).

The flanking patrols, whether of the advance cavalry or of the advance party, are sent out to examine the country wherever the enemy might be concealed. If the nature of the ground permits, these patrols march across country or along roads and trails parallel to the march of the column. For cavalry patrols this is often possible; but with infantry patrols and even with those that are mounted, reconnaissance is best done by sending the patrols to high places along the line of march to overlook the country and examine the danger points. These patrols signal the results of their observations and, unless they have other instructions, join the columns by the nearest routes, other patrols being sent out as the march proceeds and as the nature of the country requires.

Deserters, suspicious characters and bearers of flags of truce (the latter blindfolded), are taken to the advance guard commander.

1032. Advance Guard Order. On receipt of the order for a march designating the troops for the advance guard, the commander of the latter makes his estimate of the situation; that is, he looks at the map or makes inquiries to determine what sort of a country he must march through and the nature of the roads; he considers what the chances are of encountering the enemy, etc., and then how he should best arrange his advance guard to meet these conditions, and what time the different elements of his advance guard must start in order to take their proper place in the column. He then issues his order at the proper time—the evening before if possible and he deems it best, or the morning of the march.

The order for a large advance guard would ordinarily be written; for a small command it would almost invariably be verbal, except that the commander or leader of each element should always make written notes of the principal points, such as the road to be followed, time to start, distances, etc.

Problem No. 1. (Infantry)

1033. Captain (to one platoon of his company): We will assume that our battalion camped last night at Oxford ([Elementary Map](#)) in the enemy's country. It is now sunrise, 5:30 A. M.; camp has been broken and we are ready to march. The officers have returned from reporting to the major for orders and I fall in the company and give the following orders:

"A regiment of the enemy's cavalry is thought to be marching towards Salem from the south. Our battalion will march at once towards Salem to guard the railroad trestle over Sandy Creek, following this road (pointing southeast along the road out of Oxford) and the Chester Pike Which is one and three-quarters miles from here.

"This company will form the advance guard.

[Pg 316]

"Sergeant Adams, you will take Corporal Baker's squad and form the point, followed by the remainder of the company at about 400 yards. Patrols and connecting files will be furnished by the company.

"The company wagon will join the wagons of the battalion.

"I will be with the company.

"Move out at once."

The weather is fine and the roads are good and free from dust. It is August and nearly all the crops are harvested. Bushes and weeds form a considerable growth along the fences bordering the road.

Sergeant, give your orders.

Sergeant Adams: 1st squad, **1. Right, 2. FACE, 1. Forward, 2. MARCH.** Corporal Baker, take Carter (Baker's rear rank man) and go ahead of the squad about 200 yards. Move out rapidly until you get your distance and then keep us in sight.

I would then have the two leading men of the rest of the squad follow on opposite sides of the road, as close to the fence as possible for good walking. This would put the squad in two columns of files of three men each, leaving the main roadway clear and making the squad as inconspicuous as possible, without interfering with ease of marching or separating the men. [[Par. 1028 \(c\).](#)] What sort of crops are in the fields on either side of the road?

Captain: The field on the right (south) is meadow land; that on the left, as far as the railroad, is cut hay; beyond the railroad there is more meadow land.

Sergeant Adams: I would have told Corporal Baker to wait at the cross roads by the Baker house for orders and—

Captain: If you were actually on the ground you probably could not see the cross roads from Oxford. In solving map problems like these do not take advantage of seeing on the map all the country that you are supposed to go over, and then give orders about doing things at places concerning which you would not probably have any knowledge if actually on the ground without the map.

Besides, in this particular case, it was a mistake to have your point wait at the cross roads. If there was any danger of their taking the wrong road it would be a different matter, but here your mission requires you to push ahead. ([Par. 1029.](#)) The major is trying to get south of the trestle towards Salem before the cavalry can arrive and destroy it.

Sergeant Adams: I would march steadily along the road, ordering the last man to keep a lookout to the rear for signals from the connecting file ([Par. 511a](#)), and I would direct one of the leading men to watch for signals from Corporal Baker.

Captain: You should have given the direction about watching for signals earlier, as this is very important. You also should have ordered two men to follow along the timber by the creek to your south until you signaled for them to come in. The trees along the creek would obstruct your view over the country beyond the creek.

Sergeant Adams: But I thought, Captain, that the patrolling was to be done by the company.

Captain: Yes, the patrolling is to be done by the company, but the creek is only a quarter of a mile, about 400 yards, from the road you are following and the men sent there are merely flankers, not a patrol. You have eight men under your command and you are responsible for the ground within several hundred yards on either side of your route of march. Long Ridge is almost too far for you to send your men, because they would fall far behind in climbing and descending its slopes, but it would not be a great mistake if you sent two men there. As Long Ridge affords an extended view of the valley through which the Chester Pike runs, a patrol should go up on it and remain there until the battalion passes, and this would be more than the leading squad could

[Pg 317]

be expected to attend to. The creek is almost too far from the road in places, but as it is open meadow land you can keep the men within easy touch of you and recall them by signal at any moment you desire. In this work you can see how much depends on good judgment and a proper understanding of one's mission.

Corporal Baker, explain how you would move out with Carter.

Corporal Baker: We would alternate the walk and double time until we had gotten about 200 yards ahead of the squad. I would then say, "Carter, walk along this side of the road (indicates side), keeping on the lookout for signals from the squad. I will go about fifty yards ahead of you." I would keep to the opposite side of the road from Carter, trying to march steadily at the regular marching gait, and keeping a keen watch on everything in front and to the flanks.

Captain: Very good. When you arrive at the cross roads you see a man standing in the yard of the Baker house.

Corporal Baker: I would not stop, but would continue on by the cross roads, as I have no time to question the man and the Sergeant will want to do that. I would call to him and ask him if he had seen any of the enemy about and how far it was to the Chester Pike. If anything looked suspicious around the house or barnyard, I would investigate.

Captain: Sergeant, you arrive at the cross roads, and see the Corporal and Carter going on ahead of you.

Sergeant Adams: I would have already signaled to the two men following the creek to come in and would send a man to meet them with the following order: "Tell Davis to move along the railroad fill with Evans, keeping abreast of us. Then you return to me." I would then say, "Fiske, look in that house and around the barn and orchard and then rejoin me down this road (pointing east)." I would have the civilian join me and walk down the road with me while I questioned him.

Captain: Do you think you have made careful arrangements for searching the house, etc., by leaving only one man to do the work?

Sergeant Adams: I have not sufficient men nor time enough to do much more. I simply want to make sure things are reasonably safe and I thought that a couple of men from the main body of the advance guard would do any careful searching, questioning, etc., that might be deemed necessary. I must not delay the march.

Captain: That is right. You learn nothing from the civilian and he does not arouse any suspicion on your part. You continue along the road. The fields to the north of the road are in wheat stubble; the ground to the south, between your road and the railroad, is rough, rocky grass land with frequent clumps of bushes. Davis and Evans, your right flankers on the railroad fill, are just approaching the cut; Fiske has rejoined; Corporal Baker and his men are about 200 yards from the road forks at Brown's, and you and your four men are 200 yards in their rear, at the turn of the road. At this moment a half dozen shots are fired down the road in your direction from behind the wall along the edge of the orchard on the Brown farm. This firing continues and your two leading men are lying down at the roadside returning the fire. Tell me quickly just what you are going to do?

[Pg 318]

Sergeant Adams: I order my four men to deploy as skirmishers in that field (pointing to the rough ground south of the road); I go under the fence with the men and lead them forward at a fast run, unless the fire is very heavy.

Captain (interrupting the Sergeant): Davis, you had just reached the cut on the railroad when this happened. What do you do?

Private Davis: I take Evans forward with me at a run through the cut. What do I see along the Chester Pike or Sandy Creek?

Captain: You see no sign of the enemy any place, except the firing over the wall.

Private Davis: I run down the south side of the fill and along towards the road with Evans to open fire on the enemy from their flank, and also to see what is in the orchard. I will probably cross the road so that I can see behind the stone wall.

Captain: That's fine and shows how you should go ahead at such a time without any orders. There is usually no time or opportunity at such a moment for sending instructions and you must use common sense and do something. Generally it would have been better to have tried to signal or send word back that there was nothing in sight along the road or in the valley, but in this particular case you could probably do more good by going quickly around in rear as you did, to discover what was there and assist in quickly dislodging whatever it was. If there had been no nose of the ridge to hide you as you came up and a convenient railroad fill to hurry along behind as you made for the road, your solution might have been quite different.

Sergeant, continue with your movements.

Sergeant Adams: I would attempt to rush the wall. If the fire were too heavy, I would open fire (at will) with all my men, and, if I seemed to get a little heavier fire than the enemy's, I would start half of my men forward on a rush while the others fired. I would try to rush in on the enemy with as little delay as possible, until it developed that he had more than a small detachment there. I assumed it was a delaying patrol in front of me, and as my mission requires me to secure the uninterrupted march of the main body, I must not permit any small detachment to delay me. If, however, it proves to be a larger force, for instance, the head of an advance guard, I will lose some men by plunging in, but as I understand it, that is the duty of the point. Then again, if it be the head of a hostile advance guard, I will want to rush them out of their favorable position under cover of the stone wall, buildings and orchard, before any more of their force can come up. This would give the favorable position to our force; by acting too cautiously we would lose the valuable moments in which the enemy's reënforcements (next elements of the advance guard) were coming up, with this desirable position being weakly held by a small part of the enemy.

[Pg 319]

Captain: That is all correct. What messages would you have sent?

Sergeant Adams: Up to the present time I would not have sent any. I could not have sent any. I could not afford to take the time to send a man back, nor could I spare the man. Besides, all I could say was that we were fired on, and you should be able to see and hear that from where the company is.

Captain: About the time you reached the position of Corporal Baker the firing ceases, and when you reach the wall you see five mounted men galloping northeast up Farm Lane. The Brown farm appears to be deserted.

Sergeant Adams: I would turn to one of the men and say, "Run back to the Captain and tell him we were fired on from this orchard by a mounted patrol of five men who are galloping off up a lane to the northeast. I am going south." When he had repeated the message I would start south down the Chester Pike, directing Corporal Baker to follow this road south and to tell Davis to follow the high ridge west of the road, going through the clump of woods just ahead. I would send one man as a left flanker to follow the west bank of Sandy Creek. This would leave me with two men, one watching for signals from the front and along Sandy Creek, the other from Davis and from the rear. I would expect to see a patrol from the company moving across towards Boling Woods. Had I not been mixed up in a fight as I approached the Brown farm I would have sent two men as left flankers across country to the cut on the Chester Pike on the western edge of the Boling Woods.

Captain: Very good. That is sufficient for this problem. All of you should have caught the idea of the principal duties of the point and flankers of an advance guard. You must watch the country to prevent being surprised and you must at the same time manage to push ahead with the least possible delay. The point cannot be very cautious so far as concerns its own safety, for this would mean frequent halts which would delay the troops in rear, but it must be cautious about reconnoitering all parts of the ground near the road which might conceal large bodies of the enemy.

The leader of the point must be careful in using his men or he will get them so scattered that they will become entirely separated and he will lose all control of them. As soon as the necessity for flankers on one side of the line of march no longer exists, signal for them to rejoin and do not send them out again so long as you can see from the road all the country you should cover.

Problem No. 2. (Infantry)

1034. Captain (to one platoon of his company): Let us assume that this platoon is the advance party of an advance guard, marching through Salem along the Chester Pike [[Par. 1028 \(b\)](#)]. One squad is 350 yards in front, acting as the point. The enemy is thought to be very near, but only two mounted patrols have been seen during the day. The command is marching for Chester. The day is hot, the roads are good but dusty, and the crops are about to be harvested.

[Pg 320]

Sergeant Adams, explain how you would conduct the march of the advance party, beginning with your arrival at the cross roads in Salem.

Sergeant Adams: The platoon would be marching in column of squads and I would be at the head. Two pairs of connecting files would keep me in touch with the point. ([Par. 1025.](#)) I would now give this order: "Corporal Smith, take two men from your squad and patrol north along this road (pointing up the Tracy-Maxey road) for a mile and then rejoin the column on this road (Chester Pike), to the west of you." I would then say to Private Barker, "Take Carter and cut across to that railroad fill and go along the top of that (Sandy) ridge, rejoining the column beyond the ridge. Corporal Smith with a patrol is going up this road. Keep a lookout for him." When we reached the point where the road crosses the south nose of Sandy Ridge and I saw the valley in front of me with the long high ridge west of Sandy Creek, running parallel to the Chester Pike and about 800 yards west of it, I would give this order: "Corporal Davis, take the three remaining men in Corporal Smith's squad, cross the creek there (pointing in the direction of the Barton farm) go by that orchard, and move north along that high ridge, keeping the column in sight.

Make an effort to keep abreast of the advance guard, which will continue along this road."

I gave Corporal Davis the remaining men out of Corporal Smith's squad because I did not want to break up another squad and as this is, in my opinion, a very important patrol, I wanted a noncommissioned officer in charge of it. Unless something else occurs this will be all the patrols I intend sending out until we pass the steel railroad trestle over Sandy Creek.

Captain: Your point about not breaking up a squad when you could avoid it by using the men remaining in an already broken squad, is a very important one. Take this particular case. You first sent out two pairs of connecting files between the advance party and your point—four men. This leaves a corporal and three men in that squad. If we assume that no patrols were out when we passed through Salem, this corporal and two of his men could have been sent up the Tracy-Maxey road, leaving one man to be temporarily attached to some squad. From the last mentioned squad you would pick your two men for the Sandy Ridge patrol and also the corporal and three men for the Barton farm, etc., patrol. This would leave three men in this squad and you would have under your immediate command two complete squads and three men. As the patrols return, organize new squads immediately and constantly endeavor to have every man attached to a squad. This is one of your most important duties, as it prevents disorder when some serious situation suddenly arises. Also it is one of the duties of the detachment commander that is generally overlooked until too late.

The direction you sent your three patrols was good and their orders clear, covering the essential points, but as you have in a very short space of time, detached nine men, almost a third of your advance party, don't you think you should have economized more on men?

Sergeant Adams: The Sandy Ridge patrol is as small as you can make it—two men. I thought the other two patrols were going to be detached so far from the column that they should be large enough to send a message or two and still remain out. I suppose it would be better to send but two men with Corporal Davis, but I think Corporal Smith should have two with him.

[Pg 321]

Captain: Yes, I agree with you, for you are entering a valley which is, in effect, a defile, and the Tracy-Maxey road is a very dangerous avenue of approach to your main body. But you must always bear in mind that it is a mistake to use one more man than is needed to accomplish the object in view. The more you send away from your advance party, the more scattered and weaker your command becomes, and this is dispersion, which constitutes one of the gravest, and at the same time, most frequent tactical errors.

To continue the problem, we will suppose you have reached the stone bridge over Sandy Creek; the point is at the cross roads by the Smith house; you can see the two men moving along Sandy Ridge; and Corporal Davis' patrol is just entering the orchard by the Barton farm. Firing suddenly commences well to the front and you hear your point reply to it.

Sergeant Adams: I halt to await information from the point.

Captain: That is absolutely wrong. You command the advance party of an advance guard; your mission requires you to secure the uninterrupted march of the main body; and at the first contact you halt, thus interrupting the march ([Par. 1021](#)). The sooner you reach the point, the better are your chances for driving off the enemy if he is not too strong, or the quicker you find out his strength and give your commander in the rear the much desired information.

Sergeant Adams: Then I push ahead with the advance party, sending back the following message—

Captain (interrupting): It is not time to send a message. You know too little and in a few minutes you will be up with the point where you can hear what has happened and see the situation for yourself. Then you can send back a valuable message. When but a few moments delay will probably permit you to secure much more detailed information, it is generally best to wait for that short time and thus avoid using two messengers. When you reach the cross roads you find six men of the point deployed behind the fence, under cover of the trees along the County Road, just west of the Chester Pike, firing at the stone wall along the Mills' farm lane. The enemy appears to be deployed behind this stone wall, from the Chester Pike west for a distance of fifty yards, and his fire is much heavier than that of your point. You think he has at least twenty rifles there. You cannot see down the Chester Pike beyond the enemy's position. Your patrol on Sandy Ridge is midway between the 68 and 66 knolls, moving north. The ground in your front, west of the road, is a potato field; that east of the road as far as the swamp, is rough grass land.

Sergeant Adams: I give order, "Corporal Gibbs, deploy your squad to the right of the Pike and push forward between the Pike and the swamp. Corporal Hall (commands the point), continue a heavy fire. Here are six more men for your squad." I give him the four connecting files and two of the three men in the advance party whose squad is on patrol duty. "Corporal Jackson, get your squad under cover here. Lacey, run back to the major and tell him the point has been stopped by what appears to be twenty of the enemy deployed behind a stone wall across the valley 500 yards in our front. I am attacking with advance party."

[Pg 322]

Captain: Corporal Davis (commands patrol near Barton farm), you can hear the firing and see that the advance is stopped. What do you do?

Corporal Davis: I would head straight across for the clump of woods on the ridge just above the Mills' farm, moving as rapidly as possible.

Captain: That is all right. Sergeant, Corporal Hall's squad keeps up a heavy fire; Corporal Gibb's squad deploys to the right of the pike, rushes forward about 75 yards, but is forced to lie down by the enemy's fire, and opens fire. Corporal Gibbs, what would your command for firing be?

Corporal Gibbs: AT THE BOTTOM OF THAT WALL. BATTLE SIGHT. CLIP FIRE.

Captain: Why at the bottom of the wall?

Corporal Gibbs: The men are winded and excited and will probably fire high, so I gave them the bottom of the wall as an objective.

Captain: The enemy's fire seems as heavy as yours. Sergeant, what do you do?

Sergeant Adams: I give this order. "Corporal Jackson, deploy your squad as skirmishers on the left of Corporal Hall's squad and open fire." What effect does this additional fire have on the enemy?

Captain: His bullets seem to go higher and wider. You appear to be getting fire superiority over him.

Sergeant Adams: If I do not see any signs of the enemy being reënforced, dust in the road behind his position, etc., I take immediate command of the squads of Corporals Hall and Jackson, and lead them forward on a rush across the potato field.

Captain: Corporal Gibbs, what do you do when you see the other two squads rush?

Corporal Gibbs: I order, **FIRE AT WILL**, and urge the men to shoot rapidly in order to cover the advance.

Captain: Sergeant Adams' squads are forced to halt after advancing about 150 yards.

Corporal Gibbs: I keep up a hot fire until they can resume their firing, when I lead my squad forward in a rush.

Captain: What do you do, Sergeant?

Sergeant Adams: I would have the Corporals keep up a heavy fire. By this time I should think the support would be up to the cross roads.

Captain: It is, but have you given up your attack?

Sergeant Adams: If it looks as if I could drive the enemy out on my next rush, I do so, but otherwise I remain where I am, as I have no reserve under my control and the action has gotten too serious for me to risk anything more when my chief is practically on the ground to make the next decision. He should have heard something about what is on the Pike behind the enemy, from the patrol on Sandy Ridge.

[Pg 323]

Captain: Your solution seems correct to me. Why did you send Corporal Gibbs' squad up between the pike and the swamp?

Sergeant Adams: It looked as if he would strike the enemy from a better quarter; there appeared to be better cover that way, afforded by the turn in the road, which must have some weeds, etc., along it, and the swamp would prevent him from getting too far separated from the remainder of the advance party.

Captain: The Sergeant's orders for the attack were very good. He gave his squad leaders some authority and attached his extra men to a squad. He did not attempt to assume direct control of individual men, but managed the three squads and made the squad leaders manage the individual men. This is the secret of successful troop leading. His orders were short, plain and given in proper sequence.

Problem No. 3 (Infantry)

(See [Fort Leavenworth map](#) in pocket at back of book.)

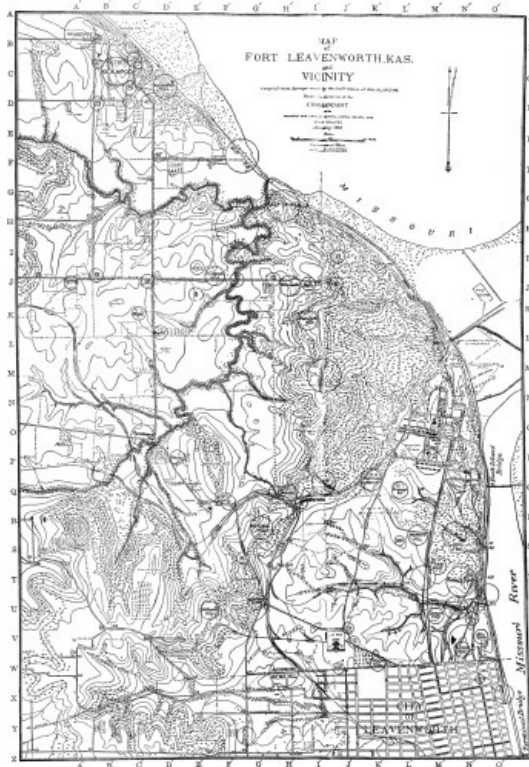

MAP of FORT LEAVENWORTH, KAS. and VICINITY ([click to enlarge](#))

1035. Situation.

A Blue battalion, in hostile country, is in camp for the night, August 5-6, at Sprong (ja'). At 9:00 P. M., August 5th, Lieutenant A, Adjutant gives a copy of the following order to Sergeant B:

1st Battalion, 1st Infantry,
Sprong, Kansas,
5 Aug., '09.

Field Orders No. 5.

1. The enemy's infantry is six miles east of FORT LEAVENWORTH. His cavalry patrols were seen at F (qg') today.

Our regiment will reach FRENCHMAN'S (oc') at noon tomorrow.

2. The battalion will march tomorrow to seize the ROCK ISLAND BRIDGE (q) at FORT LEAVENWORTH.

3. (a) The advance guard, consisting of 1st platoon Co. A and mounted orderlies B, C, and D, under Sergeant B, will precede the main body at 400 yards.

(b) The head of the main body will march at 6:30 A. M., from 19 via the 17 (jc')—15 (jg') 1—5 (lm') —FORT LEAVENWORTH (om') road.

4. The baggage will follow close behind the main body under escort of Corporal D and one squad, Co. B.

5. Send reports to head of main body.

C,
Major, Comdg.

Copies to the company commanders, to Sergeant B and Corporal D.

A. Required, 1. Give Sergeant B's estimate of the situation. (The estimate of the military situation includes the following points:

1. His orders or mission and how much discretion he is allowed.
2. The ground as it influences his duty.
3. The position, strength and probable intentions of the enemy.
4. Sergeant B's decision.)

Answer. 1. The size of the advance guard, its route and the distance it is to move in front of the main body are prescribed by Major C. Sergeant B is free to divide up the advance as he sees fit, to use the various parts so as to best keep open the way of the main body, maintain the distance of 400 yards in front of it, and protect it from surprise by the enemy.

2. The ground may be such as to make easy or to hinder reconnaissance, such as hills or woods; to impede or hasten the march, such as roads, streams, defiles; to offer good or poor defensive positions; to offer good or poor opportunities for an attack. Sergeant B sees from his map that the ground is rolling and open as far as Kern (ji') with good positions for reconnaissance and for defense or attack. There is a bridge over Salt Creek (ig') which has steep banks and will be a considerable obstacle if the bridge has been destroyed. From this creek to Kern the advance would be under effective fire from Hancock Hill (ki'), so that these heights must be seized before the main body reaches 15 (jg').

Beyond Kern the heavy woods make reconnaissance difficult and must be treated somewhat like a defile by the point. ([Par. 991.](#))

3. There is little to fear from the main body of the enemy which is 1¹/₂ miles farther from the Rock Island bridge than we are, but we know the enemy has cavalry. The size of the cavalry force is not known, and may be sufficient to cause us considerable delay, especially in the woods. The enemy's evident intention is to keep us from seizing the bridge.

4. Having considered all these points, Sergeant B comes to the following decision: ... (Before reading the decision as contained in the following paragraph, make one of your own.)

Answer: To have only an advance party with which to throw forward a point of 5 men 200 yards to the front and send out flankers, as needed ([Par. 983](#)); to send the three mounted orderlies well to the front of the point to gain early information of the enemy, especially on Hancock Hill (ji') and the ridge to the north of 11 (jj').

Required, 2. Sergeant B's order. ([Par. 963.](#))

Answer. Given verbally to the platoon and mounted orderlies, at 9:30 P. M.

"The enemy's cavalry patrols were seen at F (qh') today; no hostile infantry is on this side of the Missouri river. The battalion will move tomorrow to Fort Leavenworth, leaving 19 (ja') at 6:30 A. M.

"This platoon and orderlies B, C, and D will form the advance guard, and will start from the hedge 400 yards east of 19 at 6:30 A. M. via the 17 (jc')—15 (jg')—5 (lm') road.

"The point, Corporal Smith and 4 men of his squad, will precede the remainder of the advance guard at 200 yards.

"I will be with the advance party. Privates X and Y will act as connecting files with the main body."

The flankers will be sent out from time to time by Sergeant B as necessary.

Required, 3. The flankers sent out by Sergeant B between 19 (ja') and 15 (jg').

Answer. A patrol of 3 men is sent to Hill 900 southeast of 19 (ja'), thence by Moss (kc') and Taylor (lc') houses to Hill 840 east of Taylor, thence to join at 15 (jg').

[Pg 325]

Two men are sent from the advance party as it passes Hill 875.5 (ie') to the top of this hill to reconnoiter to the front and northeast. These men return to the road and join after the advance party has reached Salt Creek. Two men are sent ahead of the advance party at a double time take position on "Hill 875 northeast of J. E. Daniels" place (jf') and reconnoiter to the northeast and east.

Reasons. The patrol sent out on the south moves out far enough to get a good view from the hills which an enemy could observe or fire into the column. There is no necessity of sending out flankers north of the road at first, because from the road itself a good view is obtained. Hills 875.5 and 875 give splendid points for observing all the ground to the north and east. (Don't send flankers out unless they are necessary.)

Required, 4. When the advance party reaches J. E. Daniels' house (je') a civilian leaves the house and starts toward 15. What action does Sergeant B take?

Required, 5. When the advance party reaches Salt Creek bridge (jg') the point signals "enemy in sight," and Private H reports that he saw about 6 or 8 mounted men ride up to the edge of the woods at Kern, halt a moment, and disappear. What action does Sergeant B take?

Answer. He at once sends a message back by Private H stating the facts. He then orders the advance party to move forward, hastens up to the point and directs it to continue the march, seeking cover of fences and ravines and hill top.

Required, 6. When the point reaches Schroeder (jh') it receives fire from the orchard at Kern. What action is taken?

Answer. The men in the point are moved rapidly down the hill and gain shelter in the ravines leading toward Kern. Two squads are rapidly placed in line along the ridge west of Schroeder and

under cover of their fire the remainder of the advance party run down the hill at 10 yards distance to join the point. A squad of this force is then hurried forward to the Kern house. Here the squad is stopped by fire and Sergeant B deploys two more squads which advance by rushes and drive out the enemy, found to be 10 cavalymen. The squads left at Schroeder now join at double time and the advance party moves forward, without having delayed the march of the main body.

Problem No. 4 (Infantry)

1036. Situation:

A Blue force of one regiment of infantry has outposts facing south on the line Pope Hill (sm')—National cemetery (pk')—E (qh'). A Red force is reported to have reached Soldiers' Home (3 miles south of Leavenworth) from the south at 7:00 o'clock this morning. Corporal A is directed by Sergeant B, in command of the left support at Rabbit Point (tn'), to take out a patrol toward the waterworks and south along the Esplanade (xo') to the Terminal bridge.

Required, 1. Give Sergeant B's orders to Corporal A.

Answer. "The enemy, strength unknown, was at Soldiers' Home at 7:00 o'clock this morning. Another patrol will advance along Grant avenue (tm')." [Pg 326]

"Our outposts will remain here for the day.

"Select from the first section a patrol and reconnoiter this road (Farragut avenue) as far as the waterworks (vn'), thence by Esplanade to the Terminal bridge, and report on the ground in our front. When you reach the Terminal bridge return if no enemy is seen.

"Send reports here."

Required, 2. How many men does Corporal A select, and why? ([Par. 456.](#))

Answer. Five men are taken because the patrol is to reconnoiter, not to fight, and on account of the distance to go and lack of information of the enemy, 2 or 3 messages may have to be sent.

Required, 3. What equipment should Corporal A have? ([Par. 457.](#))

Required, 4. State the points to be noted by Corporal A in selecting his patrol and what inspection does he make? ([Par. 964.](#))

Answer. He selects Privates C, D, E, F and G, on account of their bravery, attention to duty and discretion. He directs them to carry one meal in their haversacks, full canteen and fifty rounds of ammunition. He then inspects them as to their physical condition, sees that they have proper equipment and that nothing to rattle or glisten is carried.

Required, 5. What does Corporal A next do? ([Par. 965.](#))

Answer. He gives them their instructions as follows: "The enemy, strength unknown, was at Soldiers' Home (about three miles south of Leavenworth) at 7 o'clock this morning. There will be a friendly patrol along that road (pointing to Grant avenue). We are to reconnoiter along this road and down toward that bridge (pointing). Be very careful not to be seen, take advantage of all cover, and keep in touch with C and myself on this road at the point of the patrol. In case we get separated meet at the waterworks (vn')." "

He then explains the signals to be used, and moves the patrol in, close order out along the road until it passes the sentinel at the bridge XV (un'), to whom he gives the direction to be taken by the patrol.

Required, 6. Upon leaving XV, what formation would the patrol take, and reasons for same. ([Par. 968.](#))

Answer. Corporal A and Private C form the point on the road leading southwest of the waterworks; Private D moves on the left overlooking the railroad; Private E moves promptly up Corral creek (um') to the top of Grant Hill (um') to observe the country toward the southwest; Private F moves about 50 yards in rear of the point, followed at 50 yards by Private G.

Corporal A forms his patrol as stated because of the necessity of getting a view from the hill on each side. Only one man is sent out on each side because they can be plainly seen by the patrol on the road, and no connecting file is necessary. The distances taken along the road assure at least one man's escape, and Corporal A is in front to get a good view and to signal the flankers.

Problem No. 5 (Infantry)

1037. Situation:

The head of the patrol is now at the bridge, XVI (un') northwest of the waterworks.

Private E has reached the top of Grant Hill and signals the enemy in sight; the patrol halts and Corporal A moves out to meet Private E who is coming down toward the patrol. He says he saw three mounted men ride up to Grant and Metropolitan avenues (wm') from the south and after looking north a moment move west.

Required, 1. Corporal A's action. ([Pars. 979](#) and [981](#).)

Answer. Corporal A at once writes the following message and sends it back by Private E:

"No. 1 Patrol, Company B,
Farragut Avenue,
Northwest of Waterworks,
10 May, '09, 8:30 A. M.

To Commander Blue Left Support,
Rabbit Point.

Three mounted Reds, seen by Private E, just now reconnoitered at Grant and Metropolitan avenues; they are moving west on Metropolitan avenue; the patrol will continue toward the Terminal bridge.

A,
Corporal."

Reasons. The message is sent because this is the first time the enemy has been seen, and they have not been reported north of Soldiers' Home before. The message should state who saw the enemy, and the man seeing them should always carry the message telling of the facts. The patrol would not allow this small hostile patrol to stop its advance, but would proceed on its route cautiously to avoid being seen, and to see if the Red cavalymen are followed by others of the enemy.

Required, 2. Give the method of reconnoitering the buildings at the waterworks and coal mine. ([Par. 996](#).)

Answer. Private D carefully examines the east side of the enclosures and buildings, while Private C examines the west side. The remainder of the patrol halts concealed in the cut west of the north enclosure, until C and D signal no enemy in sight, whereupon the patrol moves forward along the road (XV—3rd St.), C and D advancing rapidly between the buildings to the town where they join the patrol.

Required, 3. Give the route followed by E from Grant Hill to edge of Leavenworth.

Answer. He moves down the east slope of Grant Hill to the ravine just east of the old R. R. bed (um'), being careful to keep concealed from the direction of Leavenworth. He moves up the ravine, keeping a sharp lookout to the front, and moving rapidly until abreast, if he has fallen behind. He takes the branch ravine lying just west of Circus Hill (vm'), and moves up to its end. Here he halts and makes careful inspection of Metropolitan avenue and the street south into the city. Being sure the coast is clear, he darts across the narrow ridge south of Circus Hill to the ravine to the east and then joins the patrol. He reports to Corporal A any indication of the enemy he may have seen.

[Pg 328]

Problem No. 6 (Infantry)

1038. Situation:

A Blue force holds Fort Leavenworth (om') in hostile country. Outposts occupy the line Salt Creek Hill (gh')—13 (ij')—Sheridan's Drive, (mi') against the Reds advancing from the northwest.

At 4:30 P. M., June 25th, Sergeant A is given the following orders by Captain B, commanding the support:

"The enemy will probably reach Kickapoo late today. Our outposts extend as far north as Salt Creek Hill. There were six of our men prisoners at 45 (de') this afternoon at 1 o'clock, being held by 15 home guards at Kickapoo. Take —— men from the company and move to Kickapoo, recapture the prisoners and gain all the information you can of the enemy north of there."

Required, 1. How many men does Captain B name, and why? ([Par. 960](#).)

Answer. Thirty men are assigned.

Reason. This is twice as many as the enemy holding the prisoners, and to secure secrecy no

larger force than is absolutely necessary should be taken. This force will allow men to surround the enemy while the remainder rush them.

Required, 2. Give the order of Sergeant A to his patrol. (See [6th requirement, Problem 4.](#))

Required, 3. What route will the patrol take?

Answer, 11 (jj')—13 (ij')—Salt Creek Hill (gh')—and along the edge of the woods east of the M. P. R. R. (fg') as far as the bridge opposite Kickapoo Hill—thence up Kickapoo Hill toward 45 (de').

Reasons. Since the patrol's orders do not require any reconnaissance before reaching Kickapoo the shortest and most practical route is chosen. The route as far as Salt Creek Hill lies behind our outpost line and is thus protected. The main roads are avoided because they will be carefully watched by the enemy. The edge of the woods east of the M. P. Ry. (beginning about ff') gives good cover and by moving to the bridge the patrol can probably sneak close in on the enemy and capture them by surprise.

Problem No. 7 (Infantry)

1039. Situation:

The patrol reaches the top of Kickapoo Hill (cd'). Sergeant A and Private C move cautiously to the top and see the six prisoners in the cemetery (cd') just west of Kickapoo Hill, and a Red sentinel at each corner. Just west of the cemetery are about 10 more Reds. No others are visible.

Required, 1. What decision does Sergeant A make and what does he do?

Answer. He decides to capture the enemy by surprise. He leaves Private C to watch and, moving cautiously back to his patrol, makes the following dispositions: Corporal D with 10 men to move up to Private C and cover the enemy, remaining concealed. He takes the remainder of the patrol with fixed bayonets around the northeast slope of Kickapoo Hill in the woods and moves up the ravine toward 29. When his detachment arrives within about 100 yards of the enemy, they charge bayonet and rush them. Corporal D's party at the same time rush in from the opposite side. (Note: The enemy are demoralized by the surprise and are captured without a shot being fired.)

[Pg 329]

Required, 2. What action does Sergeant A now take?

Answer. He causes the enemy to be kept apart while he and his noncommissioned officers question them separately. He then questions the Blue prisoners, and furnishing them the guns taken from the Reds, sends them and the captured Reds back to our line under Corporal D, with a written message giving the information secured from his questions. ([Par. 984.](#))

Required, 3. What does he then do?

Answer. Places his main body in concealment at the Cemetery (cd') and sends a patrol under Corporal H via 35-41-43 and one under Corporal F via 29-27-23 west to learn further of the enemy in execution of the second part of his orders.

The patrol under Corporal H sends back the following message:

"No 1. Patrol, Company A, 1st Infantry,
21 June, '09; 5:30 P. M.

Commander Expeditionary Patrol at 45:

A column of infantry is moving east about 1 mile west of Schweizer (aa'); about 800 yards in front of this body is another small body with 8 to 10 men 300 yards still farther east. It took the main body 2 min., 45 sec. to pass a point on the road. I remain in observation.

H,
Corporal."

Required, 3. The size of the command reported by Corporal H and its formation. ([Par. 983.](#))

Answer. One battalion infantry (512 men), preceded by 1 section at advance guard. The advance guard having only advance party and point, $2\frac{3}{4}$ minutes \times 175 = 481 men in the main body, leaving about 32 men for the advance men for the advance guard.

Problem No. 8 (Infantry)

1040. General Situation:

A Blue force of one regiment of infantry has outposts facing south on the line Pope Hill (sm'),

National Cemetery (qk')—E (qi'). A Red force moving north reached Soldiers' Home at 7 o'clock this morning.

Special Situation:

Corporal B is chosen by Sergeant A, commander of the right support at the National Cemetery, to take a patrol south as far as 20th street (yf') and Metropolitan avenue (wh'), to report on the ground along the route, and to reconnoiter the enemy. A friendly patrol moves along Sheridan's Drive (i)—Atchison Hill (rg')—Southwest Hill (ue'), and one on Prison Lane (rk').

Required, 1. Sergeant A's orders, verbatim (that is, word for word).

2. Give the various details attended to by Corporal B before he moves out with his patrol.

3. What is the formation of the patrol when its point is at E (qh')?

[Pg 330]

4. When the patrol reaches 14 (ug'), how are the intersecting roads reconnoitered?

5. Four mounted men are seen riding west at a walk at 64 (wb'). What action does Corporal A take?

6. Describe the ground passed over by the patrol.

Problem No. 9 (Infantry)

1041. Situation:

The enemy is moving east toward Frenchman (oc') and is expected to reach there early tomorrow. A company at 72 (uj') forms the left support of an outpost in hostile country, on the line 70 (vj')—National Cemetery (qj'). At 4 P. M. Sergeant A is ordered to take a patrol of 12 men and go to Frenchman and destroy the bridge there, and remain in observation in that vicinity all night.

Required, 1. His orders to the patrol.

2. The route the patrol will follow, and its formation crossing the Atchison Hill—Government Hill ridge.

3. Give the conduct of the patrol from Atchison Hill (rg')—Government Hill (tf') to its position at the bridge at Frenchman.

General Situation:

A Blue squadron is camped for the night at Waterworks (vn'), Fort Leavenworth, and has outposts on the line XIV (un')—Grant Hill (um')—Prison Hill (wk'). A Red force is reported to be advancing from the north on Kickapoo (cb').

Problem No. 10 (Cavalry)

1042. Special Situation:

Lieutenant A, commanding the left support on Prison Hill, at 5 P. M., directs Sergeant Jones to take a patrol of 5 men from his platoon and move via Atchison Cross (ug') to the vicinity of Kickapoo and secure information of any enemy that may be in that locality. Another patrol is to go via Fort Leavenworth (ol').

Required, 1. The order given by Lieutenant A, verbatim. ([Pars. 963](#) and [965](#).)

Answer. "Sergeant Jones, the enemy is north of Kickapoo, moving on that place. This squadron will remain here tonight; Sergeant B will take a patrol through Fort Leavenworth.

"Select a patrol of 5 men from your platoon and move out via Frenchman's (oc') toward Kickapoo.

"Secure any information you can of the enemy in that locality.

"Report on the condition of the bridges between here and 47 (fd').

"You may have to stay out over night.

"Send messages here."

Sergeant Jones selects five good men, directs them to take one cooked ration each and canteen full of water. He inspects the men and horses carefully; sees that no horse of conspicuous color

[Pg 331]

or that neighs is taken. Explains the orders to his men, etc., as was done in the infantry patrol.

Required, 2. What route does the patrol take, and why?

Answer. Metropolitan avenue (w)—70 (vj')—72 (vj')—14 (ug')—Frenchman (oc')—17 (jc')—47 (ec').

Reasons. The enemy is distant and Kickapoo, the objective of the patrol, is seen from the map, which Sergeant Jones has, to be over an hour's ride at a walk and trot. It is not at all probable that the enemy will be met until the patrol reaches the vicinity of Kickapoo and Sergeant Jones decides to take the shortest and best road though it is a main highway, instead of Sheridan's Drive (j) of the F (qg')—15 (jg') lane.

It is always well for a patrol to avoid main highways when the enemy is near, especially in hostile country, but here the time saved more than justifies the use of the direct route.

Problem No. 11 (Cavalry)

1043. Same situation as Problem 1.

Required, 1. The formation and conduct of the patrol as far as Frenchman's.

Answer. Sergeant Jones determines to move at a walk and trot (5 miles per hour) in order to reach the vicinity of Kickapoo and take up a position of observation before night. Sergeant Jones and Private B are in the lead, 2 men about 100 yards to the rear, the remaining 2 men about 75 yards in the rear of these. They move out at a trot along the road until Atchison Cross is reached. The two cross roads are reconnoitered without halting the patrol, inasmuch as from the cross roads a good view is had north and south.

From Atchison Cross to 16 (sf') the patrol moves at a walk, being up a slope from 4 to 6 degrees. Usually such a place would be rushed through, but the distance of the enemy makes this unnecessary. No scouting is done off the road through the woods, because of the distance of the enemy. On reaching the top of the hill the patrol is halted while Sergeant Jones moves up to the high ground south of the road at the crest, and in concealment searches with his glasses the road as far as Frenchman's, especially the village beyond G (qf'). Seeing no signs of the enemy he moves the patrol down the hill at a walk until the cut is passed and there takes a fast trot, so as to avoid being long in a position where they could be seen from the direction of Kickapoo. The same formation and gait are maintained as far as Gauss' (pd'), where a walk is taken to rest the horses and to gain opportunity to see if any enemy are holding the bridge at Frenchman's.

Situation:

Just as the patrol comes to a walk Sergeant Jones sees what appears to be a dismounted patrol moving south over the ridge about 650 yards north of Frenchman's. He can see three men.

Required, 2. Action taken by Sergeant Jones.

Answer. The patrol is moved into the orchard just off the road, while Sergeant Jones moves quickly to the top of the hill and, concealed by the trees, examines the road north to see if the 3 men are followed by others forming a part of a larger patrol or column. He finds the three men are not followed.

[Pg 332]

Required, 3. What does he do next?

Answer. He determines to capture the patrol by surprise. He has the horses led over south of the orchard hill so as not to be visible to the enemy. He then distributes his men along the north edge of the orchard, himself nearest the bridge, 2 men 75 yards back along the road toward G (qf'), then 2 men 75 yards farther along toward G. As the third man comes opposite him, Sergeant Jones cries "Halt," which is the signal for the other parties to similarly hold up their men.

Reasons. Sergeant Jones might either capture the hostile patrol or let it pass, and then proceed on his road. Since they are the first enemy seen and there is such a good chance to capture them, and as they may furnish definite information of the enemy's main force, he decides as stated. There is an objection in capturing them that he will have to send one or two men to take them to camp. The patrol is placed as described above so as to have the two men opposite each of the enemy, except for Sergeant Jones, who is alone. By thus covering each man of the hostile patrol by two of our men, they will at once see the folly of an effort to escape and no shot need be fired. One man is holding the horses.

Problem No. 12 (Cavalry)

1044. Same situation as Problem 10.

Required:

1. What action does Sergeant Jones take before leaving the vicinity of Frenchman's?
2. Give the formation and conduct of the patrol after leaving here.
3. Give the report submitted by Sergeant Jones under his instructions in regard to bridges. ([Par. 1000.](#))

At 6:30 P. M. (it is dark at 7:30) the patrol reaches 17 (jc').

4. Give the route followed from here and the disposition of the patrol made for the night.

Problem No. 13 (Cavalry)**1045. Situation:**

The Missouri river is the boundary between hostile countries.

A Blue separate brigade (3 regiments infantry, 1 squadron cavalry, 1 battery field artillery) is moving from Winchester (19 miles west of Leavenworth) to seize the Rock Island bridge (q) across the Missouri river at Fort Leavenworth. The cavalry squadron is camped at Lowmont, 8 miles west of Leavenworth, for night June 4-5. At 3 P. M. Sergeant Jones is directed to take a patrol of six men and move via the Rock Island bridge into Missouri and gain information of the enemy reported to be now just east of the river.

Required, 1. Give the formation of the patrol when it first comes on the map.

Required, 2. Give the conduct of the patrol from Mottin's (oa') to G (qf').

At Frenchman's, Sergeant Jones met a farmer coming from Fort Leavenworth, who said about 200 hostile cavalry were seen just east of the Missouri about 2 P. M., moving towards the Terminal Bridge (z). [Pg 333]

Required, 3. Action of Sergeant Jones. (Does he hold the man? Does he send a message? Does he change his plans or direction of march?)

The patrol reaches the top of the hill, Sheridan's Drive—Government Hill (tf').

Required, 4. What action does Sergeant Jones take before proceeding east?

FLANK GUARDS

1046. The flanks of a column are ordinarily protected by the advance guard, which sends out patrols to carefully examine the country on both sides of the line of march. In some cases, however, the direction of march of the column is such that there is a great danger of the enemy's striking it in flank and some special provision is necessary to furnish additional security on the threatened flank. This is done by having a detachment, called a flank guard, march off the exposed flank. The flank guard usually follows a road, parallel to the one on which the column is marching and at least 1,000 yards (effective rifle range) beyond it. If hostile artillery is feared this distance is much greater.

The flank guard regulates its march so as to continue abreast of the advance guard of the main column. It takes a formation similar to an advance guard, does most of its patrolling to the front and on the exposed flank, and keeps in constant touch with the main column by means of mounted or dismounted messengers.

In case the enemy is encountered the flank guard drives him off if practicable or takes up a defensive position, protecting the march of the main column, and preventing the enemy from disturbing the latter's march.

REAR GUARD

1047. Definition and Duties. A rear guard is a detachment of a marching column following in rear to protect the main column from being surprised and to prevent the march from being delayed or interrupted.

When the main column is marching toward the enemy the rear guard is very small and its duties relatively unimportant. It is principally occupied in gathering up stragglers.

When the main column is marching away from the enemy (retreating) the rear guard is all important. It covers the retreat of the main body, preventing the enemy from harassing or delaying its march.

1048. Strength. The strength of a rear guard is slightly greater than that of an advance guard, as it cannot expect, like the latter, to be reinforced in case it is attacked, as the main column is marching away from it and avoiding a fight.

1049. Form of Order. The rear guard commander, on the receipt of the retreat order, issues a rear guard order, according to the form given in the Field Service Regulations.

The distance of a rear guard from the main body and its formation are similar to those of an advance guard. The elements corresponding to the advance cavalry, the point, and the advance party of an advance guard are termed the rear cavalry, rear point and rear party, respectively. The support and reserve retain the same designations.

[Pg 334]

A rear guard formed during an engagement to cover the withdrawal or retreat of the main body, may first be compelled to take up a defensive position behind which the main body forms up and moves off. It may be forced to withdraw from this position by successive skirmish lines, gradually forming up in column on the road as it clears itself from fighting contact with the enemy.

The rate of march of the rear guard depends upon that of the main body. The main body may be much disorganized and fatigued, necessitating long halts and a slow marching rate.

1050. Action of the Rear Guard. The withdrawal of defeated troops is delayed, if possible, until night. If it becomes necessary to begin a retreat while an engagement is in progress, the rear guard is organized and takes up a defensive position generally behind the fighting line; the latter then falls back and assembles under cover of the rear guard.

The rear cavalry gives away before the enemy's pursuit only when absolutely necessary, maintains communication with and sends information to the rear guard commander, and pays special attention to the weak points in the retreat, namely, the flanks. It makes use of every kind of action of which it is capable, according to the situation, and unless greatly outnumbered by hostile cavalry, it causes considerable delay to the enemy.

When the enemy is conducting an energetic pursuit the rear guard effects its withdrawal by taking up a succession of defensive positions (that is, where the nature of the ground enables the rear guard to defend itself well) and compelling the enemy to attack or turn them. (It should be understood that these successive defensive positions must, in the case of a large force, be from two to four miles apart and in the case of a small force at least one-half mile apart—not a few hundred yards as is frequently attempted in peace maneuvers.)

When the enemy's dispositions for attack are nearly completed, the rear guard begins to fall back, the cavalry on the flanks being usually the last to leave. The commander designates a part of the rear guard to cover the withdrawal of the remainder; the latter then falls back to a new position in rear, and in turn covers the withdrawal of the troops in front. These operations compel the enemy continually to deploy or make turning movements, and constantly retard his advance.

The pursuit may be further delayed by obstacles placed in the enemy's path; bridges are burned or blown up; boats removed or destroyed; fords and roads obstructed; tracks torn up; telegraph lines cut, and houses, villages, woods and fields fired. Demolitions and obstructions are prepared by engineers, assisted, if necessary, by other troops detailed from the reserve, and are completed by the mounted engineers of the rear party at the last moment.

The instructions of the supreme commander govern in the demolition of important structures.

OUTPOSTS

[Pg 335]

(See "Outpost," Par. 887)

1051. Definition and Duties. Outposts are detachments thrown out to the front and flanks of a force that is in camp or bivouac, to protect the main body from being surprised and to insure its undisturbed rest. In fact, an outpost is merely a stationary advance guard. Its duties, in general, are to *observe* and *resist*—to observe the enemy, and to resist him in case of attack. Specifically its duties are:

(a) To observe toward the front and flanks by means of stationary sentinels and patrols, in order to locate the enemy's whereabouts and learn promptly of his movements, thus making it impossible for him to surprise us.

(b) To prevent the main body from being observed or disturbed.

(c) In case of attack, to check the enemy long enough to enable the main body to prepare for action and make the necessary dispositions.

1052. Size. The size of the outpost will depend upon many circumstances, such as the size of the whole command, the nearness of the enemy, the nature of the ground, etc. A suitable strength for an outpost may vary from a very small fraction to one-third of the whole force. However, in practice it seldom exceeds one-sixth of the whole force—as a rule, if it be greater, the efficiency

of the troops will be impaired. For a single company in bivouac a few sentinels and patrols will suffice; for a large command, a more elaborate outpost system must be provided. The most economical form of outpost is furnished by keeping close contact with the enemy by means of outpost patrols, in conjunction with resisting detachments on the avenues of approach.

Troops at a halt are supposed to be resting, night or day, and the fewer on outpost the more troops will there be resting, and thus husbanding their strength for approaching marches and encounters with the enemy. Outpost duty is about the most exhausting and fatiguing work a soldier performs. It is, therefore, evident that not a man or horse more than is absolutely necessary should be employed, and that the commander should use careful judgment in determining the strength of the outpost, and the chiefs of the various outpost subdivisions should be equally careful in disposing their men so as to permit the greatest possible number to rest and sleep undisturbed, *but at the same time always considering the safety of the main body as the chief duty.*

1053. Composition. The composition of the outpost will, as a rule, depend upon the size and composition of the command, but a mixed outpost is composed principally of infantry, which is charged with the duty of local observation, especially at night, and with resisting the enemy, in case of attack, long enough for the main body to prepare for action.

The cavalry is charged with the duty of reconnaissance, and is very useful in open country during the day.

Artillery is useful to outposts when its fire can sweep defiles or large open spaces and when it commands positions that might be occupied by hostile artillery.

Machine guns are useful to command approaches and check sudden advances of the enemy.

Engineers are attached to an outpost to assist in constructing entrenchments, clearing the field of fire, opening communication laterally and to the rear. The outpost should be composed of complete organizations. For example, if the outpost is to consist of one company, do not have some of the platoons from one company and the others from another, and if it is to consist of one battalion, do not have some of the companies from one battalion and others from another, etc.

[Pg 336]

FORMATION OF OUTPOSTS

1054. Subdivisions. As in the case of an advance guard, the outpost of a large force is divided into elements or parts, that gradually increase in size from front to rear. These, in order from the main body, are the reserve, the line of supports, the line of outguards, and the advance cavalry, and their formation, as shown by the drawing on the preceding page, may be likened to an open hand, with the fingers apart and extended, the wrist representing the main body, the knuckles the line of supports, the first joints the line of outguards, the second joints the line of sentinels and the finger tips the advance cavalry.

[Pg 337]

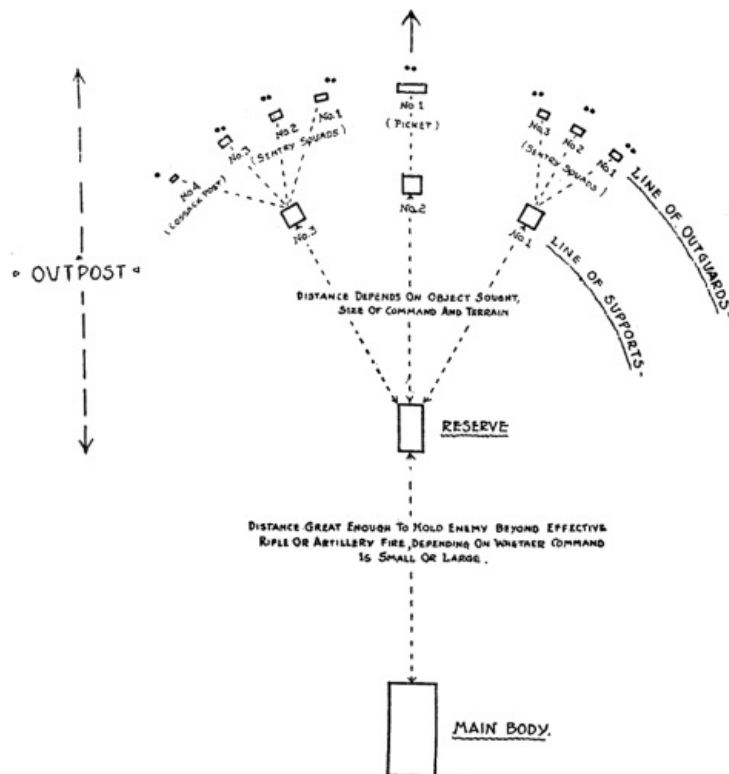

Fig. 4

In case of attack each part is charged with holding the enemy in check until the larger element, next in rear, has time to deploy and prepare for action.

1055. Distances Between the Subdivisions. The distances separating the main body, the line of supports, the line of outguards, the line of sentries and the advance cavalry, will depend upon circumstances. There can be no uniformity in the distance between supports and reserves, nor between outguards and supports, even in the same outpost. The avenues of approach and the important features of the ground will largely control the exact positions of the different parts of the outposts. The basic principle upon which the distances are based, is: *The distance between any two parts of the outpost must be great enough to give the one in rear time to deploy and prepare for action in case of attack, and the distance of the whole outpost from the main body must, in the case of small commands, be sufficiently great to hold the enemy beyond effective rifle range until the main body can deploy, and, in case of large commands, it must be sufficiently great to hold the enemy beyond effective artillery range until the main body can deploy.*

It is, therefore, evident that the distances will be materially affected not only by the size of the main body, but also by the nature of the cover afforded by the ground.

The following is given merely as a very general guide, subject to many changes:

		Distance to next element in rear.
Advance cavalry		2 to 6 miles
Supports (Generally two or more)	{	Sentinels (furnished by outguard) 20 to 40 yds. Outguards (furnished by support) 200 to 500 yds. Support proper furnishes majority of patrols. 400 to 800 yds.
Reserve (usually omitted in small commands)		$\frac{1}{2}$ to 2 miles

1056. Advance Cavalry. The advance cavalry is that part of the outpost sent out in front of all foot troops. It generally operates two to six miles beyond the outpost infantry, reconnoitering far to the front and flanks in order to guard the camp against surprise by artillery fire and to give early information of the enemy's movements.

After dusk the bulk of the cavalry usually withdraws to a camp in rear of the outpost reserve, where it can rest securely after the day's hard work and the horses can be fresh for the next day. Several mounted patrols are usually left for the night at junctions or forks on the principal roads to the front, from one to four miles beyond the infantry line of observation.

1057. Supports. The *supports* constitute a line of *supporting* and *resisting* detachments, varying in size from a half a company to a battalion. In outposts consisting of a battalion or more the supports usually comprise about one-half of the infantry. Supports are numbered numerically consecutively from right to left and are placed at the more important points on the outpost line, on or near the line on which resistance is to be made in case of attack.

[Pg 338]

As a rule, roads exercise the greatest influence on the location of supports, and a support will generally be placed on or near a road.

Each support has assigned to it a definite, clearly-defined section of front that it is to cover, and the support should be located as centrally as possible thereto.

1058. Outguards. The outguards constitute the line of small detachments farthest to the front and nearest to the enemy, and their duty is to maintain uninterrupted observation of the ground in front and on the flanks; to report promptly hostile movements and other information relating to the enemy; to prevent unauthorized persons from crossing the line of observation; to drive off small parties of the enemy, and to make temporary resistance to larger bodies. For convenience outguards are classified as pickets, sentry squads, and cossack posts. They are numbered consecutively from right to left in each support.

1059. A *picket* is a group consisting of two or more squads, ordinarily not exceeding half a company, posted in the line of outguards to cover a given sector. It furnishes patrols and one or more sentinels, double sentinels, sentry squads, or cossack posts for observation.

Pickets are placed at the more important points in the line of outguards, such as road forks. The strength of each depends upon the number of small groups required to observe properly its sector.

1060. A *sentry squad* is a squad posted in observation at an indicated point. It posts a double sentinel in observation, the remaining men resting near by and furnishing the reliefs of sentinels. In some cases it may be required to furnish a patrol.

1061. A *cossack post* consists of four men. It is an observation group similar to a sentry squad; but employs a single sentinel.

At night, it will sometimes be advisable to place some of the outguards or their sentinels in a position different from that which they occupy in the daytime. In such case the ground should be carefully studied before dark and the change made at dusk. However, a change in the position of

the outguard will be exceptional.

1062. Sentinels are generally used singly in daytime, but at night double sentinels will be required in most cases. Sentinels furnished by cossack posts or sentry squads are kept near their group. Those furnished by pickets may be as far as 100 yards away.

Every sentinel should be able to communicate readily with the body to which he belongs.

Sentinel posts are numbered consecutively from right to left in each outguard. Sentry squads and cossack posts furnished by pickets are counted as sentinel posts.

If practicable, troops on outpost duty are concealed and all movements made so as to avoid observation by the enemy; sentinels are posted so as to have a clear view to the front and, if practicable (though it is rarely possible), so as to be able, by day, to see the sentinels of the adjoining outguards. Double sentinels are posted near enough to each other to be able to communicate easily in ordinary voice.

[Pg 339]

Sentinels are generally on duty two hours out of six. For every sentinel and for every patrol there should be at least three reliefs; therefore, one-third the strength of the outguards gives the greatest number of men that should be on duty as sentinels and patrols at one time.

Skillful selection of the posts of sentinels increases their field of observation. High points, under cover, are advantageous by night as well as by day; they increase the range of vision and afford greater facilities for seeing lights and hearing noises. Observers with good field glasses may be placed on high buildings, on church steeples or in high trees.

Glittering objects on uniform or equipment should be concealed. It is seldom necessary to fix bayonets, except at night, in dense fog, or in very close country.

Reliefs, visiting patrols, and inspecting officers, approach sentinels from the rear, remaining under cover if possible.

1063. Reserve. The reserve forms a general support for the line of resistance. It is, therefore, centrally located near the junction of roads coming from the direction of the enemy, and in concealment if practicable.

Of the troops detailed for outpost duty, about one-half of the infantry, generally all of the artillery, and the cavalry not otherwise employed, are assigned to the reserve. If the outpost consists of less than two companies the reserve may be omitted altogether.

The arms are stacked and the equipments (except cartridge belts) may be removed. Roads communicating with the supports are opened.

When necessary, the outpost order states what is to be done in case of attack, designates places of assembly and provides for interior guards. Interior guards are posted in the camp of the reserve or main body to maintain order, and furnish additional security. Additional instructions may be given for messing, feeding, watering, etc. In the vicinity of the enemy or at night a portion of the infantry may be required to remain under arms, the cavalry to hold their horses (cinches loosened), and the artillery to remain in harness, or take up a combat position.

In case of alarm, the reserve prepares for action without delay, and word is sent to the main body. In combat, the reserve reinforces the line of resistance, and if unable to check the enemy until the arrival of the main body, delays him as much as possible.

The distance of the reserve from the line of resistance varies, but is generally about half a mile; in outposts of four companies or less this distance may be as small as 400 yards.

1064. Patrols. Instead of using outguards along the entire front of observation, part of this front may be covered by patrols only. These should be used to cover such sections of the front as can be crossed by the enemy only with difficulty and over which he is not likely to attempt a crossing after dark.

In daylight much of the local patrolling may be dispensed with if the country can be seen from the posts of the sentinels. However, patrols should frequently be pushed well to the front unless the ground in that direction is exceptionally open.

[Pg 340]

Patrols must be used to keep up connection between the parts of the outpost except when, during daylight, certain fractions or groups are mutually visible. After dark this connection must be maintained throughout the outpost except where the larger subdivisions are provided with wire communication.

The following patrols are usually sent out from the main bodies of the supports:

(a) Patrols of from three men to a squad are sent along the roads and trails in the direction of the enemy, for a distance of from one to five miles, depending on how close the enemy is supposed to be, whether or not there is any advance cavalry out, and how long the outpost has been in position. The extreme right and left supports send patrols well out on the roads to the flanks.

These patrols generally operate continuously as soon as one returns from the front, or possibly even before it returns, another goes out in the same general direction to cover the same country. Frequently a patrol is sent out along a road to the front for two or three miles with orders to remain out until some stated time—for example, 4 P. M., dusk or dawn. It sends in important information, and remains out near the extremity of its route, keeping a close watch on the surrounding country.

An effort should always be made to secure and maintain contact with the enemy, if within a reasonable distance, in order that his movements or lack of movement may be constantly watched and reported on. The usual tendency is towards a failure to send these patrols far enough to the front and for the patrol leader to overestimate the distance he has traveled. A mile through strange country with the ever-present possibility of encountering the enemy seems three miles to the novice.

At night the patrols generally confine their movements to the roads, usually remaining quietly on the alert near the most advanced point of their route to the front.

The majority of such patrols are sent out to secure information of the enemy—reconnoitering patrols—and they avoid fighting and hostile patrols, endeavoring to get in touch with the enemy's main force. Other patrols are sometimes sent out to prevent hostile detachments from approaching the outposts; they endeavor to locate the hostile patrols, drive them back, preventing them from gaining any vantage point from which they can observe the outpost line. These are called combat patrols and have an entirely different mission from reconnoitering patrols.

(b) Patrols of from two men to a squad, usually two men, are sent from the support around the line of its outguards, connecting with the outguards of the adjacent supports, if practicable. These are "visiting patrols," and they serve to keep the outguards of a support in touch with it and with each other; to keep the commander of a support in touch with his outguards and the adjacent supports; and to reconnoiter the ground between the outguards. Since a hostile force of any size is practically forced to keep to the roads, there are rarely ever any supports and very few outguards posted off the roads, the intervals being covered by patrols, as just described.

When going out a patrol will always inform the nearest sentinel of the direction it will take and its probable route and hour of return.

[Pg 341]

1065. Detail for Patrols. Since for every patrol of four men, twelve are required (3 reliefs of 4 men each), the importance of sending out just enough men and not one more than is actually needed, can readily be understood. As fast as one visiting patrol completes its round, another should usually be sent out, possibly going the rounds by a slightly different route or in the reverse direction. The same generally applies to the reconnoitering and combat patrols, though frequently they are sent out for the entire day, afternoon or night, and no 2d and 3d relief is required. Three reliefs are required for the sentinel or sentinels at the post of the supports, so care should be taken to establish but one post, if it can do all that is required. It should not be considered that every man in the support should be on duty or on a relief for an outguard, a patrol or sentinel post. There should be as many men as possible in the main body of a support (this term is used to distinguish this body from the support proper, which includes the outguards and their sentinels) who only have no duty other than being instantly available in case of attack.

1066. Flags of Truce. Upon the approach of a flag of truce, the sentry will at once notify the commander of the outguard, who will in turn send word to the commander of the outpost and ask for instructions. One or more men will advance to the front and halt the party at such distance as to prevent any of them from overlooking the outposts. As soon as halted, the party will be ordered to face in the opposite direction. If permission is given to pass the party through the outpost line, they will be blindfolded and led under escort to the commander of the outpost. No conversation, except by permission of the outpost commander, is to be allowed on any subject, under any pretext, with the persons bearing the flag of truce.

1067. Entrenchments and Obstacles. The positions held by the subdivisions of an outpost should generally be strengthened by the construction of entrenchments and obstacles, but conditions may render this unnecessary.

1068. Concealment. Troops on outpost must keep concealed as much as is consistent with the proper performance of their duties; especially should they avoid the sky line.

1069. Detached Posts. In addition to ordinary outguards, the outpost commander may detail from the reserve one or more detached posts to cover roads or areas not in general line assigned to the supports.

In like manner the commander of the whole force may order detached posts to be sent from the main body to cover important roads or localities not included in the outpost line.

Detached posts may be sent out to hold points which are of importance to the outpost cavalry, such as a ford or a junction of roads; or to occupy positions especially favorable for observation, but too far to the front to be included in the line of observation; or to protect flanks of the outpost position. Such posts are generally established by the outpost commander, but a support

commander might find it necessary to establish a post practically detached from the rest of his command. They usually vary in strength from a squad to a platoon. The number and strength of detached posts are reduced to the absolute needs of the situation.

1070. Examining Posts. An examining post is a small detachment, under the command of an officer or a noncommissioned officer, stationed at some convenient point to examine strangers and to receive bearers Of flags of truce brought in by the outguards or patrols.

Though the employment of examining posts is not general in field operations, there are many occasions when their use is important; for example: When the outguards do not speak the language of the country or of the enemy; when preparations are being made for a movement and strict scrutiny at the outguards is ordered: at sieges, whether in attack or defense. When such posts, are used, strangers approaching the line of observation are passed along the line to an examining post.

No one except the commander is allowed to speak to persons brought to an examining post. Prisoners and deserters are at once sent under guard to the rear.

1071. Cavalry Outpost. Independent cavalry covering a command or on special missions, and occasionally the advance cavalry of a mixed command, bivouac when night overtakes them, and in such cases furnish their own outposts. The outposts are established, in the main, in accordance with the foregoing principles, care being taken to confine outpost work to the lowest limits consistent with safety. No precaution, however, should be omitted, as the cavalry is generally in close proximity to the enemy, and often in territory where the inhabitants are hostile.

The line of resistance is occupied by the supports, the latter sending out the necessary outguards and patrols. Each outguard furnishes its own vedettes (mounted sentinels), or sentinels. Due to the mobility of cavalry, the distances are generally greater than in an outpost for a mixed command. An outguard of four troopers is convenient for the day time, but should be doubled at night, and at important points made even stronger. The sentinels are generally dismounted, their horses being left with those of the outguards.

Mounted cavalry at night can offer little resistance; the supports and outguards are therefore generally dismounted, the horses being under cover in rear, and the positions are strengthened by intrenchments and obstacles. By holding villages, bridges, defiles, etc., with dismounted rifle fire, cavalry can greatly delay a superior force.

There should always be easy communication along the line of resistance to enable the cavalry to concentrate at a threatened point.

A support of one squadron covers with its outposts a section rarely longer than two miles.

As such a line is of necessity weak, the principal reliance is placed on distant patrolling. If threatened by infantry, timely information enables the threatened point to be reinforced, or the cavalry to withdraw to a place of safety. If there is danger from hostile cavalry, the roads in front are blocked at suitable points, such as bridges, fords, defiles, etc., by a succession of obstacles and are defended by a few dismounted men. When compelled to fall back these men mount and ride rapidly to the next obstacle in rear and there take up a new position. As the march of cavalry at night is, as a rule, confined to roads, such tactics seriously delay its advance.

In accordance with the situation and the orders they have received, the support commanders arrange for feeding, watering, cooking, resting and patrolling. During the night the horses of the outguards remain saddled and bridled. During the day time cinches may be loosened, one-third of the horses at a time. Feeding and watering are done by reliefs. Horses being fed are removed a short distance from the others.

Independent cavalry generally remains in outpost position for the night only, its advance being resumed on the following day; if stopped by the enemy, it is drawn off to the flanks upon the approach of its own infantry.

ESTABLISHING THE OUTPOST

1072. The outpost is posted as quickly as possible, so that the troops can the sooner obtain rest. Until the leading outpost troops are able to assume their duties, temporary protection, known as the *march outpost*, is furnished by the nearest available troops.

Upon receipt of the *halt order* from the commander of the main column, the outpost commander issues the *outpost order* with the least practicable delay.

The *halt order*, besides giving the necessary information and assigning camp sites to the parts of the command, details the troops to constitute the outpost, assigns a commander therefor, designates the general line to be occupied, and, when practicable, points out the position to be held in case of attack.

The *outpost order* gives such available information of the situation as is necessary to the complete and proper guidance of subordinates; designates the troops to constitute the supports;

assigns their location and the sector each is to cover; provides for the necessary detached posts; indicates any special reconnaissance that is to be made; orders the location and disposition of the reserve; disposes of the train if the same is ordered to join the outpost; and informs subordinates where information will be sent. In large commands it may often be necessary to give the order from the map, but usually the outpost commander will have to make some preliminary reconnaissance, unless he has an accurate and detailed map.

Generally it is preferable for the outpost commander to give verbal orders to his support commanders from some locality which overlooks the terrain. The time and locality should be so selected that the support commanders may join their commands and conduct them to their positions without causing unnecessary delay to their troops. The reserve commander should, if possible, receive his orders at the same time as the support commanders. Subordinates to whom he gives orders separately should be informed of the location of other parts of the outpost.

1073. After issuing the initial orders, the outpost commander inspects the outpost, orders the necessary changes or additions, and sends his superior a report of his dispositions.

The reserve is marched to its post by its commander, who then sends out such detachments as have been ordered and places the rest in camp or bivouac, over which at least one sentinel should be posted. Connection must be maintained with the main body, the supports, and nearby detached posts.

[Pg 344]

The supports march to their posts, using the necessary covering detachments when in advance of the march outpost. A support commander's order should fully explain the situation to subordinates, or to the entire command, if it be small. It should detail the troops for the different outguards and, when necessary, define the sector each is to cover. It should provide the necessary sentinels at the post of the support, the patrols to be sent therefrom, and should arrange for the necessary intrenching.

In posting his command the support commander must seek to cover his sector (the front that he is to look after) in such manner that the enemy can not reach, in dangerous numbers and unobserved, the position of the support or pass by it within the sector intrusted to the support. On the other hand, he must economize men on observation and patrol duty, for these duties are unusually fatiguing. He must practice the greatest economy of men consistent with the requirements of practical security.

As soon as the posting of the support is completed, its commander carefully inspects the dispositions and corrects defects, if any, and reports the disposition of his support, including the patrolling ordered, to the outpost commander. This report is preferably made by means of a sketch.

By day the outpost will stack arms and the articles of equipment, except the cartridge belt and canteen, will be placed by the arms. At night the men will invariably sleep with their arms and equipment near them.

In addition to the sentinel posted over the support, a part of the support, say one-third or one-fourth, should always be awake at night.

Each outguard is marched by its commander to its assigned station, and especially in the case of a picket, is covered by the necessary patrolling to prevent surprise.

Having reached the position, the commander explains the situation to his men and establishes reliefs for each sentinel, and, if possible, for each patrol to be furnished. Besides these sentinels and patrols, a picket must have a sentinel at its post.

The commander then posts the sentinels and points out to them the principal features, such as towns, roads, and streams, and gives their names. He gives the direction and location of the enemy, if known, and of adjoining parts of the outpost.

He gives to patrols the same information and the necessary orders as to their routes and the frequency with which the same shall be covered. Each patrol should go over its route once before dark.

Each picket should maintain connection by patrols with the outguards on its right and left.

1074. Intercommunication. It is most important that communication should be maintained at all times between all parts of the outpost, and between the outpost and the main body. This may be done by patrols, messengers, wire or signal.

[Pg 345]

The commander of the outpost is responsible that proper communication be maintained with the main body, and the support commanders keep up communication with the outguards, with the adjoining supports and with the reserve. The commander of a detached post will maintain communication with the nearest outguard.

1075. Changes for the Night. In civilized warfare, it is seldom necessary to draw the outpost closer to the main body at night in order to diminish the front; nor is it necessary to strengthen the line of observation, as the enemy's advance in force must be confined to the roads. The latter

are therefore strongly occupied, the intervening ground being diligently patrolled.

In very open country or in war with savage or semi-civilized people familiar with the terrain, special precautions are necessary.

1076. Relieving the Outpost. Ordinarily outposts are not kept on duty longer than twenty-four hours. In temporary camps or bivouac they are generally relieved every morning. After a day's advance the outpost for the night is usually relieved, the following morning when the support of the new advance guard passes the line of resistance. In retreat the outpost for the night usually forms the rear guard for the following day, and is relieved when it passes the line of observation of the new outpost.

Outguards that have become familiar with the country during the day time should remain on duty that night. Sentinels are relieved once in two hours, or oftener, depending on the weather. The work of patrols is regulated by the support commander.

Commanders of the various fractions of an outpost turn over their instructions and special orders, written and verbal, to their successors, together with the latest information of the enemy, and a description of the important features of the country. When practicable the first patrols sent out by the new outposts are accompanied by members of the old outpost who are familiar with the terrain. When relieved the old outguards return to their supports, the supports to the reserve and the latter to the main body; or, if more convenient, the supports and reserves return to the main body independently, each by the shortest route.

When relieved by an advance guard, the outpost troops ordinarily join their units as the column passes.

Evening and shortly before dawn are hours of special danger. The enemy may attack late in the day in order to establish himself on captured ground by intrenching during the night; or he may send forward troops under cover of darkness in order to make a strong attack at early dawn. Special precaution is therefore taken at those hours by holding the outpost in readiness, and by sending patrols in advance of the line of observation. If a new outpost is to be established in the morning it should arrive at the outpost position at daybreak, thus doubling the outpost strength at that hour.

OUTPOST PROBLEMS

[Pg 346]

Problem No. 1 (Infantry)

1077. Lieutenant (to two squads of his company): Two battalions of our regiment have camped by Baker's Pond ([Elementary Map](#)) for the night. It is now 3 P. M. on a rainy day in August. The enemy is thought to be about five miles to the south of us. Our platoon is the left support of the outpost and is stationed at the road fork on the Chester Pike, by the Mason house. The Twin Hills-Lone Hill ridge is taken care of by other troops. Corporal Baker, where do you think I should place outguards?

Corporal Baker: One at the junction of the Mills farm lane and the Chester Pike, and one at the steel railroad trestle over Sandy Creek.

Lieutenant: Those positions are both too far from the support, almost a half mile, but they cover the two main avenues of approach and there is no good place for a position nearer the support. A position farther north of the Mill's farm lane would have its view obstructed by the wall and trees along the lane and the wall would be a bad thing to leave unoccupied such a short distance to your front. So in this case, in spite of the excessive distances from the support, I think the two positions are well chosen. Each should be an outguard of a squad, for in the day time, in addition to furnishing a sentinel to observe to the front, they should have some power of resistance, particularly at the trestle. At night they should each have one double sentinel post. This requires three reliefs of two men each, which, with the corporal, only leaves one extra man, who can be used as a messenger.

Corporal Baker, I order you to take your squad and post it as Outguard No. 1, at the junction of this (Chester) pike and that farm lane (Mills farm) in front. Corporal Davis' squad will be Outguard No. 2, at the railroad trestle over there (pointing). Friendly troops will be on the ridge to the east of your position. Your meals will be cooked here and sent to you.

Explain how you post your squad.

Corporal Baker: I order Smith to double time 150 yards to the front and act as point for the squad. I then march the squad down to its position, keeping Smith about 200 yards in front until I have arranged everything. I then post Brown under cover of the trees along the lane where he can look down the road as far as possible and I tell him, "Brown, you are to take post here, keeping a sharp lookout to the front and flanks. The enemy is thought to be about five miles south (pointing) of us. This is the Chester Pike. That creek over there is Sandy Creek. Salem is about a mile and three-quarters down this pike in that (S. E.) direction. York is a mile and a half

in that (S. W.) direction. Our troops are on that ridge (Twin Hills) and a squad is at the trestle over there. It is Outguard No. 2. You are in Outguard No. 1. You know where we left our platoon. It is our support. Signal Smith to come in." I then have the squad pitch their shelter tents along the northern side of the wall, where they will be hidden to view from the front by the trees along the lane and the wall. I want the men to get shelter from the rain as soon as possible. I then instruct the men of the squad, in the same manner that I did Brown; I notice the time, and detail Davis as second relief and Carter as third relief for Brown's post.

[Pg 347]

I then direct two men to take all the canteens and go over to that farm (Mills) and fill them, first questioning the people about the enemy and about the country around here. I also direct these two men to get some straw or hay for bedding in the shelter tents, and instruct them to return with as little delay as possible.

I wait until they return and order two other men to go down to the cross roads, question the people there, look the ground over and return here. I caution them not to give any information about our force or the outguard. I would see that the sentinel's position was the best available and that the men had as comfortable quarters as possible, without being unduly exposed to view and without interfering with their movements in case of attack. They would keep their rifles at their sides at all times and not remove their equipments. After dark I put two men on post at the same time. To do this I arrange three reliefs of two men each. They are posted in pairs for two hours at a time.

If no patrol from the support appeared within a half hour after I first took position I would send a messenger back to you to see if everything was all right and tell you what I had done.

Lieutenant: I think the two men sent to the crossroads should have been started out before sending anyone to the Mills house as this was a more important point. The Field Service Regulations state that outguards do not patrol to the front, but what you did was entirely correct. You were securing yourself in your position and should be familiar with your immediate surroundings. You should have told the crossroads patrol to determine how much of an obstacle Sandy Creek was. I suppose you assumed the swamp was impassable.

The sentinel in this case is, I suppose, across the lane from the outguard about ten or fifteen yards in advance. After dark the double sentinel post should be posted on the pike about thirty yards in advance of the outguard.

Very frequently it would not be wise to put up your shelter tents on outguard. But here, considering the rain and the protection the trees and wall furnish, it was wise to do so.

The noncommissioned officer in charge of an outguard should be very precise in giving his orders and in making his arrangements, details, etc. The discipline must be strict; that is, the men must be kept under absolute control, so that in case of sudden attack there will be no chance of confusion and the outguard commander will have his men absolutely in hand and not permit any independent action on their part. This is often not the case, owing to the familiar relations that usually exist in our army between a corporal and the members of his squad.

We will not have time to go into the arrangements for Outguard No. 2 other than to say that the conditions there are somewhat different from those Corporal Baker has had to deal with. The outguard should be posted on the west bank of Sandy Creek and the sentinel at the southeastern end of the trestle. A skirmish trench should be dug down the western slope of the fill west of the creek, and extended across the track by throwing up a parapet about two and one-half feet high, slightly bent back towards the northeast so as to furnish cover from fire from the east bank of the creek, north of the trestle. The shelter tents could be pitched as "lean tos" against the western slope of the fill, and hidden by bushes and branches of trees.

[Pg 348]

(Note: The details of commanding this outguard, its action in case of attack, what should be done with a passing countryman, etc., can be profitably worked out in great detail.)

Problem No. 2

1078. Lieutenant (to six squads): We will take the same situation as we had in Problem 1, with squad outguards as before.

Sergeant Adams, you have command of the platoon and have sent out the two outguards. Explain your arrangements for the support.

Sergeant Adams: I have the men fall out by squads and rest on the side of the road while I look the ground over. I then tell Sergeant Barnes, "You will have immediate charge of the guard, cooking, visiting patrols, etc., here at the support. Detail three men from Corporal Evan's squad as first, second and third relief for the sentinel over the support Post your sentinel at the road fork and give him the necessary instructions as to the outguards, the adjacent support which is on this road (pointing west) on top of that ridge, etc. I will give you further instructions later." I then fall in the remainder of the support (one sergeant, one cook, four corporals and twenty-seven privates, three squads being intact and one man on duty as sentinel) and have shelter tents

pitched under cover of the orchard and Mason house. While this is being completed I select a line for a trench, about thirty-five yards long, behind the fence on the east and west road and extending east of the Chester Pike about fifteen yards, slightly bent back towards the northeast. No trench in the road. I then say to Sergeant Foss, "Take Graves' squad and construct a shelter trench along this line (indicating) having the parapet concealed. Cut the fences so as to furnish easy access."

I then say to Corporal Evans, "Take three men from your squad and, as a reconnoitering patrol, cross the trestle there (pointing), and follow that road (pointing to the Boling-Salem road) into Salem, reconnoitering that village. Then take up a position on that ridge (pointing to Sandy Ridge) and remain out until dusk. Send me a message from Sandy Ridge with a sketch and description of the country."

I assume that Corporal Evans is familiar with the information about the enemy, the location of our outguards, etc.

Selecting five men from Corporal Geary's squad and the remaining man of Corporal Evans' squad (three having been detailed for sentinel duty, and three sent out on patrol duty with Corporal Evans), I turn them over to Sergeant Barnes, saying, "Here are six men to furnish three reliefs for a visiting patrol of two men. Have this patrol visit Outguard No. 2 and cross the trestle, going south down the east bank of the creek; thence recross the creek at the road bridge, visiting Outguard No. 1; thence across to the adjacent outguard of the support on our left, which is somewhere on that ridge (pointing to the Twin Hills-Lone Hill Ridge); and thence to the starting point. Have them locate that support on their first trip. You can reverse the route and make such minor changes from time to time as you think best. Report to me after they have completed the first round. Make arrangements for sending supper to the outguards. Take two men from Corporal Jackson's squad to carry it out. Be careful that the cook fire is not visible. I am going out to visit Outguard No. 1 and then No. 2. You will have charge until I return."

[Pg 349]

The men have stacked arms in front of the tents and have removed all equipment but their belts.

I would now visit the outguards, taking a man with me, and see if they are properly located. I would instruct the outguard commanders as to what to do in case of attack, in case strangers approach, point out their line of retreat in case of necessity, etc. I would make a sketch of the position and send it, with a description of my dispositions, to the commander of the outpost.

Lieutenant: Your arrangements and dispositions appear satisfactory. You should have been more prompt in sending Corporal Evans out with his patrol. Why didn't you send a patrol towards York, or south along the Chester Pike?

Sergeant Adams: I considered that the support on my right would cover that ridge (Twin Hills-Lone Hill), and that the route I laid out for Corporal Evans would cover the Chester Pike and the country east of Sandy Creek at the same time, thus avoiding the necessity for two patrols.

Lieutenant: That seems reasonable, but you should have given some specific orders about reporting on the width, depth, etc., of Sandy Creek, which might prove a very valuable or dangerous obstacle. You can readily see how quickly a command becomes broken up and depleted in strength, and how important it is to make only such detachments as are necessary. It looks as if your outguards might have been made smaller considering the size of your platoon (6 squads), but I think the squad outpost is so much better than one not composed of a complete unit, that it is correct in this case. With Corporal Evans' patrol of three men, the visiting patrol requiring six men, the sentinel post requiring three men, Sergeant Barnes, and the two outguards, you have thirty men actually on duty or detailed for duty, out of fifty-one. Of course, the men constituting the outguards, the man detailed for the visiting patrol and support sentinel, have approximately two hours on duty and four hours off duty, so they get some rest. Furthermore, you should have a three-man patrol watching the crossroads at Salem during the night, Corporal Evans' patrol having returned. This patrol should be relieved once during the night, at a previously stated hour, which means six more men who do not get a complete night's rest.

Sergeant Adams: Isn't Salem rather far to the front to send a patrol at night?

Lieutenant: Yes, it is, but unless you touch the crossroads there you would have to have two patrols out, one near Maxey's farm and one on the Chester Pike. As it is you are leaving the road from York to the crossroads in front of Outguard No. 1 uncovered, but you should find that this is covered by a patrol from the adjacent support. The cross roads in front of Outguard No. 1 is the natural place for a stationary, night patrol, but it is so close to the outguard that the benefit derived from a patrol there would be too small to justify the effort.

[Pg 350]

(Note: Further details of the duties of this support can be gone into. The messages should be written, and patrols carried through their tour of duty with the resulting situations to be dealt with; the sentinels tested as to their knowledge of their duties, etc. Also note carefully the manner in which the support commander uses his noncommissioned officers for carrying out his intentions, and thus avoids the most objectionable and inefficient practice of dealing directly with the privates.)

Problem No. 3 (Infantry)

1079. (See [Fort Leavenworth map](#) in pocket at back of book.)

Situation:

A Blue force, Companies A and B, 1st Infantry, under Captain A, in hostile country, is covering the Rock Island Bridge and camped for the night, April 20-21, on the south slope of Devin ridge (rm'). The enemy is moving northward from Kansas City (30 miles south of Leavenworth). At 3:30 P. M. Captain A receives a message from Colonel X at Beverly (2 miles east of Rock Island Bridge, (qo')), stating that two or three companies of hostile infantry are reported five miles south of Leavenworth at 2:30 P. M. No enemy is west of Leavenworth. Captain A decides to place one platoon on outpost.

Required, 1. Captain A's order.

Answer. Verbally: "Two or three Red companies were five miles south of Leavenworth at 2:30 P. M. today. No enemy is west of Leavenworth. We will camp here. 1st Platoon, 'A' company, under Sergeant A, will form the outpost, relieving the advance guard (2d Platoon Co. A). The line, Pope Hill (sm')—Rabbit Point (tn') will be held. Detached posts will be placed on Hill 880, west of Merritt Hill (rl'), and on Engineer Hill (ql'). In case of attack the outpost line will be held.

"The baggage will be at the main camp.

"Messages will reach me on Devin Ridge (rm')."

Issued verbally to officers and Sergeant A.

Required, 2. Give verbatim (word for word) the order issued by Sergeant A.

Answer. "Two companies of the enemy were five miles south of Leavenworth at 2:30 P. M. today. Our camp is to be here. This platoon will be the outpost on the line, Rabbit Point (im')—Pope Hill (sm').

"The right support, 1st section, less 1 squad, under Sergeant B, will take position north of Pope Hill and cover the following front: the ravine (XIX—Merritt Hill) west of Grant avenue to the ravine about midway between Grant Avenue and Rabbit Point (tn').

"The left support, 2d section, less 1 squad under Sergeant H, will take position on north slope of Rabbit Point and will cover the following front: The ravine midway between Grant Avenue and Rabbit Point to Missouri River.

"Corporal D, you will take the eight men of your squad and form a detached post on Engineer Hill (qk').

"Corporal E, take your squad and form a detached post on Hill 880 west of Merritt Hill (rl').

[Pg 351]

"If attacked hold your front. Each support and detached post will entrench.

"Send messages to me at right support."

The outpost moves out, each support and detached post separately, without throwing out covering patrols, because the advance guard is now holding the front. There is no reserve.

Required, 3. What does Sergeant A do now?

Required, 4. What does Sergeant B do as soon as he reaches Pope Hill?

(Note: During the remainder of the afternoon one man up in a tree on Grant Avenue will be the only observing post necessary for this support. At night an outguard would be placed on Grant Avenue with continuous patrols along the front, because the open ground furnishes easy approach to the enemy. A post of four men might also be placed on the bridge over Corral Creek (um').)

Required, 5. The location of supports and the main body of detached post on Engineer Hill.

Required, 6. What patrolling would be done from the left support?

CHAPTER VI

[Pg 352]

THE COMPANY ON OUTPOST

(Establishing the Outpost)

1080. We will now apply some of the general principles of outposts (see [Par. 1051](#)) to a company taking up its position on the line of outposts.

Let us suppose that our battalion has been detailed for outpost duty.

In order to understand more fully the duties and functions of the company commander, we will first consider what the major does. To begin with, he and the battalion will have been detailed for outpost duty before the march was completed, and he will have been told, amongst other things, what is known of the enemy and also what is known of other bodies of our own troops, where the main body will halt, the general position to be occupied by the outpost, and what the commander intends doing in case of attack.

The major verbally designates, say, two companies, as the reserve, and the other two companies, including our own, as the support. He places the senior officer of the reserve companies in command of the reserve and tells him where he is to go, and he indicates the general line the outpost is to occupy and assigns the amount of front each of the other companies is to cover. The limits of the sector so assigned should be marked by some distinctive features, such as trees, buildings, woods, streams, etc., as it is important that each company should know the exact limits of its frontage. He tells the company commanders what he knows of the enemy and of our own troops so far as they affect the outposts, he indicates the line of resistance and how much resistance is to be afforded in case of attack, states whether intrenchments and obstacles are to be constructed, gives instructions about lighting fires and cooking, and states where he can be found.

Upon receiving his orders from the major, the company commander, *with a proper covering detachment*, moves to the locality allotted him and as he arrives upon the ground he is to occupy, he sends out, as temporary security, patrols or skirmishers, or both, a short distance in front of the general position the outguards will occupy, holding the rest of the company back under cover. If practicable, the company commander should precede the company and make a rapid examination of the ground. He then sends out *observation groups*, varying in size from four men to a platoon, generally a squad, to watch the country in the direction of the enemy. These groups constitute the *outguards*, and are just sufficient in number to cover the front of the supports, and to connect where necessary with the outguards of adjoining supports.

The company commander next selects a defensive position on the general line of resistance, from which not only can he command the approaches, but where he can also give assistance to the adjoining supports; he then gives instructions in regard to the intrenchments and obstacles, after which he makes a more careful reconnaissance of the section assigned him; corrects the position, of the outguards, if necessary; gives them instructions as to their duties in case of attack or when strangers approach their posts; tells them the number (if any) of their post, the number of the outguard and support and the numbers of the adjoining outguards and supports; points out lines of retreat in case they are compelled to fall back to the support, cautioning the men not to mask the fire of the support; he tells them the names of all villages, rivers, etc., in view, and the places to which the wagon roads and the railroads lead; selects, if necessary, places for additional posts to be occupied at night and during fog; sees that suitable connections are made between him and the adjoining outguards, and between his support and the adjoining supports; and questions subordinate commanders to test their grasp of the situation and knowledge of their duties, and on returning to the support he sends a report with a *sketch* to the outpost commander, showing the dispositions made.

[Pg 353]

After the line of observation has been established, the support stacks arms and the men are permitted to remove their equipments, except cartridge belts. One or more sentinels are posted over these supports, and they guard the property and watch for signals from the outguards. Fires are concealed as much as possible and the messing is done by reliefs. Mounted messengers ordinarily do not unsaddle; they rest, water and feed as directed.

After the major has received reports from both company commanders, he will himself visit the outguards and supports and make such changes as he may deem necessary, immediately after which he will submit to the commander of the troops a written report, accompanied by a combined sketch showing the positions of the different parts of the outpost. The major might begin his inspection of the line of outguards before receiving the reports of the company commanders.

In training and instructing the company in outpost work, it is always best to send out a few patrols and scouts an hour or two in advance, with definite instructions as to what they are to do, and have them operate against the company as hostile scouts and patrols. If the rest of the company know that patrols and scouts are operating in their front, and will try to work their way through the outpost line, they will naturally take a keener interest in their work. Exercises of this kind create a feeling of rivalry between the scouts and patrols, who, on the one hand, are trying to work their way through the line of outposts, and the outguards and patrols, who, on the other hand, are trying to prevent them from so doing. It makes the work much more *human*.

1081. The general principles of patrolling are explained in [Par. 959](#); so we need not repeat them here.

Many of the principles of scouting are, in reality, nothing but the fundamentals of patrolling, and the main function of scouting, *reconnoitering*, is also the function of a certain class of patrols. So, we see that scouting and patrolling are inseparably connected, and the importance of training the members of the company in the principles of scouting is, therefore, evident.

1082. Requisites of a good Scout. A man, to make a good scout, should possess the following qualifications:—

- Have good eyesight and hearing;
- Be active, intelligent and resourceful;
- Be confident and plucky;
- Be healthy and strong;
- Be able to swim, signal, read a map, make a rough sketch, and, of course, read and write.

1083. Eyesight and Hearing. To be able to use the eye and the ear quickly and accurately is one of the first principles of successful scouting. Quickness and accuracy of sight and hearing are to a great extent a matter of training and practice. The savage, for instance, almost invariably has quick eyesight and good hearing, simply from continual practice.

Get into the habit of seeing, *observing*, things—your eyesight must never be resting, but must be continually glancing around, in every direction, and *seeing* different objects. As you walk along through the country get into the habit of noticing hoof-prints, wheel-ruts, etc., and observing the trees, houses, streams, animals, men, etc., that you pass.

Practice looking at distant objects and discovering objects in the distance. On seeing distant signs, do not jump at a conclusion as to what they are, but watch and study them carefully first.

Get into the habit of listening for sounds and of distinguishing by what different sounds are made.

1084. Finding your Way in a strange Country. The principal means of finding one's way in a strange country are by map reading, asking the way, the points of the compass and landmarks.

Map Reading. This, of course, presupposes the possession of a map. The subject of map reading is explained in [Pars. 1859](#) to 1877.

Asking the Way. In civilized countries one has no trouble in finding his way by asking, provided, of course, he speaks the language. If in a foreign country, learn as soon as you can the equivalent of such expressions as "What is the way to —?" "Where is —?" "What is the name of this place?" and a few other phrases of a similar nature. Remember, however, that the natives may sometimes deceive you in their answers.

[Pg 355]

Points of the Compass. A compass is, of course, the best, quickest and simplest way of determining the directions, except in localities where there is much iron, in which case it becomes very unreliable.



For determining the points of the compass by means of the North Star and the face of a watch, see [Par. 1096](#).

The points of the compass can also be ascertained by facing the sun in the morning and spreading out your arms straight from the body. Before you is east; behind you, west; to your right, south; to your left, north.

The points of the compass can be determined by noting the limbs and bark of trees. The bark on the north side of trees is thicker and rougher than that on the south side, and moss is most generally found near the roots on the north side. The limbs and branches are generally longer on the south side of the trees, while the branches on the north are usually knotty, twisted and drooped. The tops of pine trees dip or trend to the north.

1085. Lost. In connection with finding your way through strange country, it may be said, should you find you have lost your way, do not lose your head. Keep cool—try not to let your brains get into your feet. By this we mean don't run around and make things worse, and play yourself out. First of all, sit down and think; cool off. Then climb a tree, or hill, and endeavor to locate some familiar object you passed, so as to retrace your steps. If it gets dark and you are not in hostile territory, build a good big fire. The chances are you have been missed by your comrades and if they see the fire, they will conclude you are there and will send out for you. Also, if not in hostile territory, distress signals may be given by firing your rifle, but don't waste all your ammunition.

If you find a stream, follow it; it will generally lead somewhere—where civilization exists.

The tendency of people who are lost is to travel in a circle uselessly.

Remember this important rule: *Always notice the direction of the compass when you start out, and what changes of direction you make afterwards.*

1086. Landmarks. Landmarks or prominent features of any kind are a great assistance in finding one's way in a strange country. In starting out, always notice the hills, conspicuous trees, high buildings, towers, rivers, etc. For example, if starting out on a reconnaissance you see directly to the north of you a mountain, it will act as a guide without your having to refer to your compass or the sun. If you should start from near a church, the steeple will serve as a guide or landmark when you start to make your way back.

When you pass a conspicuous object, like a broken gate, a strangely shaped rock, etc., try to remember it, so that should you desire to return that way, you can do so by following the chain of landmarks. On passing such landmarks always see what they look like from the other side; for, that will be the side from which you will first see them upon the return, trip.

[Pg 356]

The secret of never getting lost is to note carefully the original direction in which you start, and after that to note carefully all landmarks. Get in the habit of doing this in time of peace—it will then become second nature for you to do it in time of war.

It may sometimes be necessary, especially in difficult country, such as when traveling through a forest, and over broken mountains and ravines, for you to make your own landmarks for finding your way back by "blazing" (cutting pieces of bark from the trees), breaking small branches off bushes, piling up stones, making a line across a crossroad or path you did not follow, etc.

1087. Concealment and Dodging. Both in scouting and patrolling it must be remembered not only that it is important you should get information, but it is also fully as important that the enemy should not know you have the information—hence, the necessity of hiding yourself. And remember, too, if you keep yourself hidden, not only will you probably be able to see twice as much of what the enemy is doing, but it may also save you from being captured, wounded or killed.

Should you find the enemy has seen you, it is often advisable to pretend that you have not seen him, or that you have other men with you by signaling to imaginary comrades.

As far as possible, keep under cover by traveling along hedges, banks, low ground, etc. If moving over open country, make your way as quickly as possible from one clump of trees or bushes to another; or, from rocks, hollows or such other cover as may exist, to other cover. As soon as you reach new cover, look around and examine your surroundings carefully.

Do not have about you anything that glistens, and at night be careful not to wear anything that jingles or rattles. And remember that at night a lighted match can be seen as far as 900 yards and a lighted cigarette nearly 300 yards. In looking through a bush or over the top of a hill, break off a leafy branch and hold it in front of your face.

In selecting a tree, tower or top of a house or other lookout place from which to observe the enemy from concealment, always plan beforehand how you would make your escape, if discovered and pursued. A place with more than one avenue of escape should be selected, so that if cut off in one direction you can escape from the other. For example, should the enemy reach the foot of a tower in which you are, you would be completely cut off, while if he reached a house on whose roof you happened to be, you would have several avenues of escape.

Although trees make excellent lookout places, they must, for the same reasons as towers, be used with caution. In this connection it may be remarked unless one sees foot marks leading to a tree, men are apt not to look up in trees for the enemy—hence, be careful not to leave foot marks. When in a tree, either stand close against the trunk, or lie along a large branch, so that your body will look like a part of the trunk or branch.

[Pg 357]

In using a hill as a lookout place, do not make the common mistake of showing yourself on the skyline. Reach the top of the hill slowly and gradually by crouching down and crawling, and raise your head above the crest by inches. In leaving, lower your head gradually and crawl away by degrees, as any quick or sudden movement on the skyline is likely to attract attention. And, remember, just because you don't happen to see the enemy that is no sign that he is not about. At maneuvers and in exercises soldiers continually make the mistake of exposing themselves on the skyline.

At night confine yourself as much as possible to low ground, ditches, etc. This will keep you down in the dark and will enable you, in turn, to see outlined against the higher ground any enemy that may approach you.

At night especially, but also during the day, the enemy will expect you along roads and paths, as it is easier to travel along roads and paths than across country and they also serve as good guides in finding your way. As a rule, it is best to use the road until it brings you near the enemy and then leave it and travel across country. You will thus be able better to avoid the outposts and patrols that will surely be watching the roads.

Practice in time of peace the art of concealing yourself and observing passers-by. Conceal yourself near some frequented road and imagine the people traveling over it are enemies whose

numbers you wish to count and whose conversation you wish to overhear. Select a spot where they are not likely to look for you, and which has one or more avenues of escape; choose a position with a background that matches your clothes in color; keep quiet, skin your eyes; stretch your ears.

A mounted scout should always have wire cutters when operating in a country where there are wire fences.

1088. Tracking. By "tracking" we mean following up footmarks. The same as the huntsman tracks his game so should we learn how to track the enemy. One of the first things to learn in tracking is the pace at which the man or horse was traveling when the track was made.

A horse walking makes pairs of footmarks, each hind foot being close to the impression of the forefoot. At a trot the tracks are similar, but the pairs of footmarks are farther apart and deeper, the toe especially being more deeply indented than at the walk. At a canter there are two single footmarks and then a pair. At a gallop the footmarks are single and deeply indented. As a rule, the hind feet are longer and narrower than the forefeet.

In case of a man walking, the whole flat of the foot comes equally on the ground, the footmarks usually about 30 inches apart. If running, the toes are more deeply indented in the ground, and the footmarks are considerably farther apart than when walking. Note the difference between footmarks made by soldier's shoes and civilian's shoes, and those made by men and those made by women and children.

Study the difference between the tracks by a gun, a carriage, an escort wagon, an automobile, a bicycle, etc., and the direction in which they were going.

[Pg 358]

In addition to being able to determine the pace of tracks, it is most important that you should be able to tell how old they are. However, ability to do this with any degree of accuracy, requires a vast amount of practice. A great deal depends on the kind and the state of the ground and the weather. For example, if on a dry, windy day you follow a certain track over varying ground, you will find that on light sandy soil, for instance, it will look old in a very short time, because any damp earth that may have been kicked up from under the surface will dry very quickly to the same color as the rest of the surface, and the edge of the footmark will soon be rounded off by the breeze blowing over the dry dust. The same track in damp ground will look much fresher, and in damp clay, in the shade of trees, a track which may be a day old will look quite fresh.

The following are clues to the age of tracks: Spots of rain having fallen on them since they were made, if, of course, you know when the rain fell; the crossing of other tracks over the original ones; the freshness or coldness of the droppings of horses and other animals (due allowance being made for the effect of the sun, rain, etc.), and, in the case of grass that has been trodden down, the extent to which it has since dried or withered.

Having learned to distinguish the pace and age of tracks, the next think to do is to learn how to follow them over all kinds of ground. This is a most difficult accomplishment and one that requires a vast amount of practice to attain even fair proficiency.

In tracking where it is difficult to see the track, such as on hard ground, or in the grass, note the direction of the last foot-print that you can see, then look on ahead of you a few yards, say, 20 or 30, in the same direction, and, in grass, you will probably see the blades bent or trodden, and, on ground, you will probably see stones displaced or scratched—or some other small sign which otherwise would not be noticed. These indistinct signs, seen one behind the other, give a track that can be followed with comparative ease.

If you should lose the track, try to find it again by placing your handkerchief, hat, or other object on the last footmark you noticed, and then work around it in a wide circle, with a radius of, say, 30, 50, or 100 yards, choosing the most favorable ground, soft ground, if possible. If with a patrol, only one or two men should try to find the onward track; for, if everyone starts in to find it, the chances are the track will be obliterated with their footmarks. In trying to find the continuation of a track this way, always place yourself in the enemy's position, look around the country, imagine what you would have done, and then move out in that direction and look for his tracks in soft ground.

PRACTICE

In order to learn the appearance of tracks, get a suitable piece of soft ground, and across this have a man walk and then run, and have a horse walk, trot, canter and gallop. The next day make similar tracks alongside the first ones and then notice the difference between the two. Also, make tracks on ordinary ground, grass, sand, etc., and practice following them up. Finally, practice tracking men sent out for the purpose. The work will probably be very difficult, even disheartening at first, but you will gradually improve, if you persevere.

[Pg 359]

Above all things, get into the habit of seeing any tracks that may be on the ground. When out walking, when going through exercises at maneuvers, and at other times, always notice what tracks are on the ground before you, and study them.

The following exercises in scouting and patrolling afford excellent practice and training:

1089. The Mouse and Cat Contest. 1. A section of country three or four miles square, with well-defined limits, is selected. The boundaries are made known to all contestants and anyone going outside of them will be disqualified.

2. Two patrols of eight men each are sent out as "mice." They occupy any positions they may wish within the boundaries named, and conceal themselves to watch for hostile patrols.

3. Half an hour later two other squads, wearing white bands around their hats, or having other distinguishing marks, are sent out as "cats" to locate, if possible, and report upon the position of the "mice."

4. An hour is fixed when the exercise shall end, and if within the given time the "cats" have not discovered the "mice," the "mice" win.

5. The "cats" will write reports of any "mice" patrols they may see.

Rules

1. An umpire (officer or noncommissioned officer) goes with each patrol and his decisions as to capture and other matters are the orders of the company commander. The umpires must take every possible precaution to conceal themselves so as not to reveal the position of the patrols with which they are.

Each umpire will carry a watch, all watches being set with that of the company commander before the exercise commences.

2. Any "cat" patrol coming within 50 yards of a "mouse" patrol, without seeing the "mice," is considered captured.

3. When the time is up, the umpires will bring in the patrols and report to the company commander.

1090. Flag-Stealing Contest. 1. A section of country of suitable size, with well-defined limits, is selected, the boundaries being made known to the contestants.

2. The contestants are divided into two forces of about 20 men each, and each side will establish three Cossack posts along a general line designated by the company commander, the two positions being selected facing each other and being a suitable distance apart. The men not forming part of the Cossack posts will be used as reconnoitering patrols.

3. About three quarters of a mile in rear of the center of each line of outposts four flags will be planted, in line, about 30 yards apart.

4. The scouts and patrols of each force will try to locate the outposts of the other force, and then to work their way around or between them, steal the flags and bring them back to their own side. They will endeavor to prevent the enemy from doing the same.

[Pg 360]

5. One scout or patrol will not carry away more than one flag at a time, and will have to return to their side safely with the flag before they can come back and capture another.

6. Scouts may work singly or in pairs. Any scout or patrol coming within 80 yards of a stronger hostile party, or Cossack post, will be considered as captured, if seen by the enemy, and if carrying a captured flag at the time, the flag will not count as having been captured. Of course, if a scout or patrol can pass within 80 yards of the enemy without being discovered, it may do so.

7. An umpire (officer or noncommissioned officer) will be with each Cossack post, each patrol, and at the position of the flags.

8. The hour when the exercise ends will be designated in advance and at that hour the umpires will bring in the Cossack posts and patrols. The same requirements regarding watches obtains as in the Mouse and Cat Contest.

9. At the conclusion of the contest the commander of each side will hand in to the company commander all sketches and reports made by his men.

10. Points will be awarded as follows:

Each flag captured, 5.

For each sketch and hostile report of the position of a Cossack post, 3.

For each report of movements of a hostile patrol, 2.

The side getting the greatest number of points will win.

11. Umpires may penalize the contestants for a violation of the rules.

The same contest may be carried out at night, substituting lighted Japanese lanterns for the

FOOTNOTES:

[13] The best book on scouting that the author has ever seen, is Baden-Powell's "Aids to Scouting," which was consulted in the preparation of this chapter.

CHAPTER VIII

[Pg 361]

NIGHT OPERATIONS

1091. Importance. Because of the long range and great accuracy of modern fire arms, there has been in recent years a marked increase in the practice of night operations, such operations being of common occurrence not only for massing troops under cover of darkness in favorable positions for further action, but also for actually assaulting positions.

Read carefully [pars. 464, 496, 498, 523, 524, 580-590](#).

TRAINING OF THE COMPANY

1092. Night movements are amongst the most difficult operations of war, and, therefore require the most careful, painstaking and thorough training and instruction of troops in all matters pertaining thereto. The history of night fighting shows that in most cases defeat is due to disorganization through panic. It is said that in daylight the moral is to the physical as three is to one. That being the case, it is hard to say what the ratio is at night, when a general atmosphere of mystery, uncertainty and fear of surprise envelops the operations, and, of necessity affects the nerves of the men. The vital importance, therefore, of accustoming troops as much as we can in peace to the conditions that will obtain in night fighting, cannot be overestimated. The following outline shows the subjects in which individual and collective instruction and training should be given:

INDIVIDUAL TRAINING

1093. General. The first thing to be done is to accustom the soldier to darkness and to teach him to overcome the nervousness which is natural to the average man in darkness.

The best way to do this is to begin by training him in the use of his powers of vision and hearing under conditions of darkness, which are strange to him. The company should be divided into squads for this instruction.

1094. Vision. Take several men to ground with which they are familiar. Have them notice the different appearance which objects present at night; when viewed in different degrees of light and shade; the comparative visibility of men under different conditions of dress, background, etc.; the ease with which bright objects are seen; the difference between the visibility of men standing on a skyline and those standing on a slope. Post the men in pairs at intervals along a line which the instructors will endeavor to cross without being seen. The instructors should cross from both sides, so as to compel observation in both directions. Have a man (later, several) walk away from the rest of the men and when he is about to disappear from view, halt him, and estimate the distance. Send a man (later, several) outside the field of vision, to advance on the rest of the men. Halt him when he enters the field of vision and estimate the distance. Send a number of men outside the limit of vision and then let them advance on the rest of the men, using cover and seeing how near they can approach unobserved.

[Pg 362]

1095. Hearing. Place a number of men a few yards apart and make them guess what a noise is caused by, and its approximate position. The rattle of a meat can, the movement of a patrol, the working of the bolt of a rifle, the throwing down of accouterments, low talking, etc., may be utilized. Take special pains to impress upon the men the penetrating power of the human voice, and the necessity of preserving absolute silence in night operations. Have blank cartridges fired and teach the men to judge their direction and approximate distance away.

1096. Finding Bearings. Show the men how to determine the points of the compass from the North Star. The Big Dipper constellation looks like this:

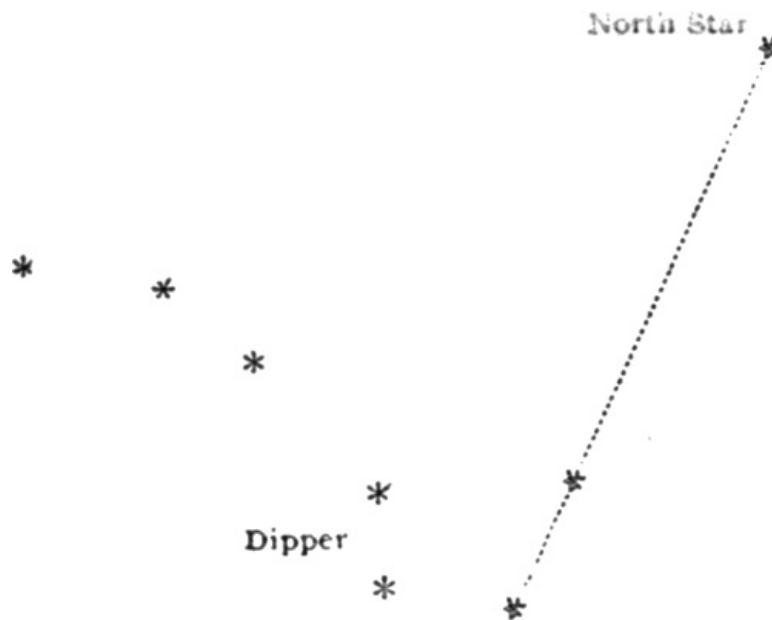

Fig. 1

The North Star is on the prolongation of a line joining the two "pointing" stars, and at above five times the distance between the two stars. At another time have those same men individually locate the North Star. Using this star as a guide, practice the men moving in different directions, by such commands as, "Smith, move southeast." "Jones, move northwest," etc.

To test a man's ability to keep a given direction when moving in the darkness, choose a spot from which no prominent landmarks are visible, advance toward it accompanied by a man, from a distance not less than 200 paces. While advancing the soldier must take his bearings. On arriving at the spot chosen the instructor will turn the soldier around rapidly two or three times and then have him continue to advance in the same direction as before. No prominent landmarks should be visible from the starting point.

1097. Moving in the Dark. Form four or five men in line with about one pace interval, the instructor being on one of the flanks. Place some clearly visible mark, such as a lantern, for the instructor to march on. Impress upon the men the importance of lifting their feet up high and bringing them to the ground quietly and firmly, and of keeping in touch with the guide and conforming to his movements without sound or signal. The pace should be slow and frequent halts should be made to test the promptness of the men in halting and advancing together. As the line advances, each man will in turn take his place on the flank and act as guide. The light on which the men are marching should be hidden from view at intervals, in order to test the ability of the men to maintain the original direction. Later on, the number of men in a line may be increased considerably. The rougher the ground, the darker the night and the longer the line, the slower must the pace be and the more frequent the halts. After passing an obstacle men instinctively line up parallel to it, and consequently if the obstacle does not lie at right angles to the line of advance, the direction will be lost; so, be sure to guard against this.

[Pg 363]

1098. Night Fencing. Practice the men in charging in the dark against a white cloth or the dummy figure of a man. In the beginning have the figure in a fixed place, but later have the soldier charge seeking the figure, and not knowing just exactly where it is beforehand.

1099. Night Entrenching. It is frequently necessary in time of war to dig trenches at night in front of the enemy, and while this work is easy in the moonlight, it is very difficult in the dark. Bear in mind the following points:

1. The tendency is to make the trench too narrow; hence, guard against this.
2. Be careful not to throw the earth too far or too near.
3. Do not strike your neighbor's tools in working.
4. Do not use the pick unless necessary, because it makes considerable noise.
5. Do not scrape the tools together in order to get off the dirt; use a chip of wood or the toe of the shoe.
6. Make as little noise as possible in digging and handling your tools.
7. If discovered by the enemy's searchlights, do not become excited or confused; simply lie down.
8. If attacked by the enemy, do not get rattled and throw your tools away—put them in some fixed place where they can be found again.

1100. Equipment. At first the men should be taken out without arms, but later on they should be trained to work in full equipment. Teach every man what parts of his equipment are likely to

make a noise under special circumstances, such as lying down, rising, crossing obstacles, etc., and instruct him how to guard against it. Bayonets should always be fixed, but in order to avoid accidents the scabbard should be left on them.

From the beginning of the training continually impress upon the men that it is absolutely criminal to fire without orders during a night operation and that the bayonet is the only weapon he can use with advantage to himself and safety to his comrades.

1101. Night Firing. As a rule men fire too high in the dark. They must, therefore, be cautioned not to raise the rifle above the horizontal, or incline the upper part of the body to the rear. When the firing is stopped be sure to turn on the safety-lock. Experience during the Russo-Japanese War taught the Japanese the kneeling position is the most suitable for horizontal firing. The following method, to be conducted in daytime, may be employed in training the soldier to hold his rifle parallel to the ground while firing in the dark:—Have each soldier, kneeling, close his eyes and bring his rifle to the position of aim, barrel parallel to the ground. With the rifle in this position, let him open his eyes and examine it. Then have this done by squad, by command. When they become proficient in this movement, have them close their eyes and while the eyes are closed, put up a target and have them practice horizontal firing, opening their eyes each time after pulling the trigger and then examining the position of the piece.

[Pg 364]

COLLECTIVE TRAINING

At first practice squads, then the platoons and later the company in simple movements, such as squads right and left, right and left oblique, etc., gradually leading up to more complicated ones in close and extended order, such as right and left front into line, advancing in platoon and squad columns, charging the enemy, etc. As far as possible the movements should be executed by simple prearranged signals from the unit commanders. The signals, which must not be visible to the enemy, may be made with a white handkerchief or a white flag, if the night be not too dark; with an electric flashlight, a dark lantern or luminous disk. The light of the flashlight or lantern must be screened, so it cannot be seen by the enemy. The following signals are suggested:

To advance: Raise vertically the lantern or other object with which the signal is made.

To halt: Lower and raise the object several times.

To lie down: Bring the object down near the ground.

To form squad columns: Move the object several times to the right and left.

To form platoon columns: Describe several circles.

As skirmishers: Move the object front to rear several times.

1102. Night Marches. In acting as an advance guard to a column, the company would send out a point a few yards ahead, which would be followed by the rest of the company. Three or four scouts should be sent out a hundred yards or so ahead of the point. They should advance at a quick pace, keeping in the shadow on the side of the road, being constantly on the alert, using their ears even more than their eyes. They will halt to listen at crossroads and suspicious places, and move on again when they hear the company approaching. Should the enemy be discovered, one of the scouts will return to warn the advance guard—the others will conceal themselves and watch. Under no circumstances must the scouts ever fire, unless it be for the purpose of warning the company and there is no other way of doing so. The diagram on the opposite page is suggested as a good formation for a company acting as advance guard at night. A company marching alone would move in the same formation as when acting as advance guard, except that it would protect its rear with a few scouts. Of course, the nature of the country and proximity and activity of the enemy, will determine the best formation to be used, but whatever the formation may be, always remember to cover well your front, rear and flanks, with scouts, whose distance away will vary with the light and nature of the country. *Don't forget that protection in rear is very important.*

[Pg 365]

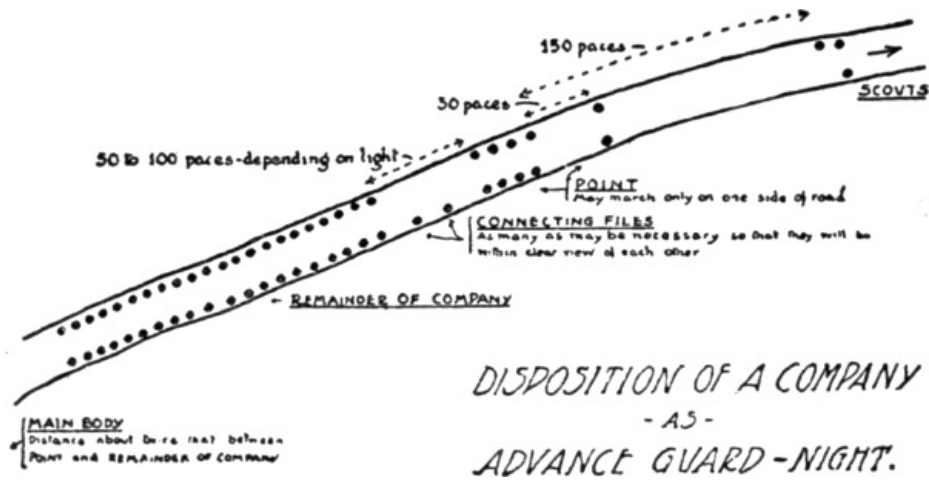

Fig. 2

The men must be warned against firing, smoking, talking, striking matches, making noise, etc. They should also be informed of the object in view, direction of the enemy, etc.

In night marches the rests should not exceed five minutes; otherwise, many men will fall asleep.

OUTPOSTS

Careful training in outpost duty at night is very harassing, but, in view of its importance, should not be neglected. This instruction should be given with the greatest thoroughness, strictness and attention to detail.

1103. Sentries Challenging. In challenging sentries must be careful to avoid any noise that would disclose their position. In fact, challenging by voice should be reduced to a minimum by arranging a system of signals by which the officers of the day, patrols, etc., can be recognized. The following signals, any one of which may be decided upon, which would be made first by the sentry and then answered by the approaching party, are suggested: Clap the hands together twice; strike the ground twice with the butt of the rifle; strike the butt of the rifle twice with the hand; whistle softly twice. The replying signal would be the same as the sentry's signal, except that in case of the use of the butt of the rifle, an officer would reply by striking twice on his revolver holster. After repeating the signal once, if it is not answered, the sentry will challenge with the voice, but no louder than is necessary. In case of a patrol only one man will advance to be recognized after the signal has been answered. The sentry must always allow persons to approach fairly near before challenging.

1104. Sentries Firing. Anyone who has been through a campaign knows how nervous green sentries are, and how quick they are about firing. During the beginning of the Philippine Campaign the author heard of several cases where sentries fired on fire-flies several hundred yards away. Never fire unless it be absolutely necessary to give an alarm, or unless you can clearly distinguish the enemy and are fairly certain of hitting him. In the French Army in Algeria, there is a rule that any sentry who fires at night must produce a corpse, or be able to show by blood marks that he hit the person fired at. If he can do neither, he is punished for giving a false alarm.

[Pg 366]

1105. Marking of Route from Outguards to Supports. The route from the support to the outguards, and from pickets to their sentries, should, if necessary, be clearly marked with scraps of paper, green sticks with the bark peeled off, or in any other suitable way.

1106. Readiness for Action. The supports should always be ready for action. The men must sleep with their rifles beside them and in such places that they will be able to fall in promptly in case of attack. Some men have a way of sleeping with their blankets over their heads. This should not be allowed—the ears must always be uncovered. The commander, or the second in command, with several men, should remain awake. When the commander lies down he should do so near the sentry, which is always posted over the support.

GENERAL

1107. Connections. It is of the greatest importance that proper connection be maintained between the different parts of a command engaged in night operations. It is astonishing with what facility units go astray and how difficult it is for them to find their way back where they belong.

1108. Preparation. It matters not what the nature of the night operation may be, the most careful preparation is necessary. Success often depends upon the care and thoroughness with which the plans are made.

All possible eventualities should be thought of and provided for as far as practicable. The first thing to do is to get as much information as possible about the ground to be covered and the

position of the enemy, and care must be taken to see that the information is accurate. Reconnaissance must be made by night as well as by day; for, ground looks very different at night from what it does during the day.

CHAPTER IX

[Pg 367]

FIELD ENGINEERING

1109. The following, from the **Engineer Field Manual**, together with the elements of field engineering covered in [Chapter XI](#), on **Obstacles**, will give the company officer a good, working knowledge of those parts of field engineering for which he is most likely to have need.

Bridges

1111. Dimensions and guard rail. A roadway 9 ft. wide in the clear should be provided to pass infantry in fours, cavalry two abreast, and military wagons in one direction; a width of 6 ft. will suffice for infantry in column of twos, cavalry in single file, and field guns passed over by hand.

The *clear width* of roadway of an ordinary highway bridge should not be less than 12 ft. for single track, or 20 ft. for double track.

The *clear head room* in ordinary military bridges should not be less than 9 ft. for wagons and cavalry; for highway bridges not less than 14 ft.

Ramps at the ends of a bridge, if intended for artillery, should not be steeper than 1 on 7. For animals, slopes steeper than 1 on 10 are inconvenient.

If the bridges are high, hand rails should be provided. A single rope may suffice, or it may have brush placed upon it to form a screen.

A guard rail should be provided along each side of the roadway, near the ends of the flooring planks. In hasty bridges it may be secured by a lashing or lashings through the planking to the stringer underneath. Otherwise it may be fastened with spikes or bolts.

1112. Spar bridges.—This name is applied to bridges built of round timbers lashed together. Intermediate points of support are provided by inclined frames acting as struts to transmit weight from the middle of the bridge to the banks. The single-lock and double-lock bridges with two and three spans of 15 ft., respectively, are the ones of most utility.

The first step in constructing a spar bridge is to measure the gap to be bridged and select the position of the footings on either bank. Determine the distance from each footing to the middle point of the roadway if a single-lock, or the two corresponding points of a double-lock bridge. Next determine and mark on each spar except the diagonals the places where other spars cross it. The marking may be done with chalk, or with an ax. If possible a convenient notation should be adopted. As, for example, in marking with chalk, a ring around the spar where the edge of the crossing spar will come, and a diagonal cross on the part which will be hidden by the crossing spar.

A simple way to determine the length of spars is the following: Take two small lines somewhat longer than the width of the gap, double each and lash the bights together. Stretch them tightly across the gap so that the lashing comes at the middle as at *A*, [Fig. 8](#). Release one end of each and stretch it to the footing on the same side as indicated by the dotted lines. Mark each line at the footing *C* or *C'*, and at the position chosen for the abutment sill, *B* or *B'*. Cut the lashing and take each piece of rope to its own side. The distances *AB* and *AB'* are the lengths between the transoms, and with 2 ft. added give the length of road bearers required. The distances *AC* and *AC'* are the lengths of struts from butt to top of transom, and with 3 ft added, give the total length of spars required.

[Pg 368]

For a double lock bridge, a piece of rope of a length equal to the length of the middle bay replaces the lashing. If the banks are not parallel, a measurement should be taken on each side of the bridge.

If desired, a section of the gap may be laid down on the ground in full size and the lengths of spars determined by laying them in place. This method, though given as standard by all authorities, requires more time and more handling of material than the other and gives no better results.

The construction of a frame is shown in [Fig. 1](#), and the system of marking in [Fig. 2](#). The arrangement of frames to form a single lock bridge is shown in [Figs. 3](#) and [4](#), and a double lock bridge in [Fig 6](#).

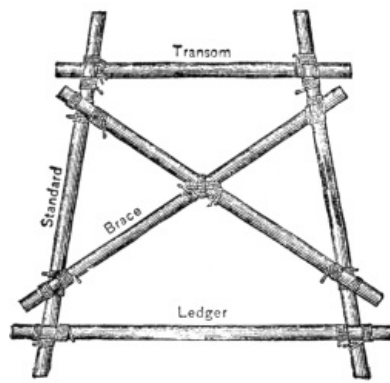

Fig. 1

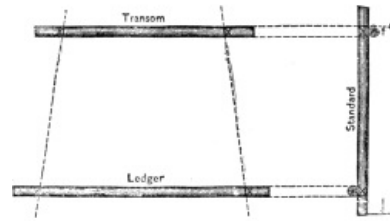

Fig. 2

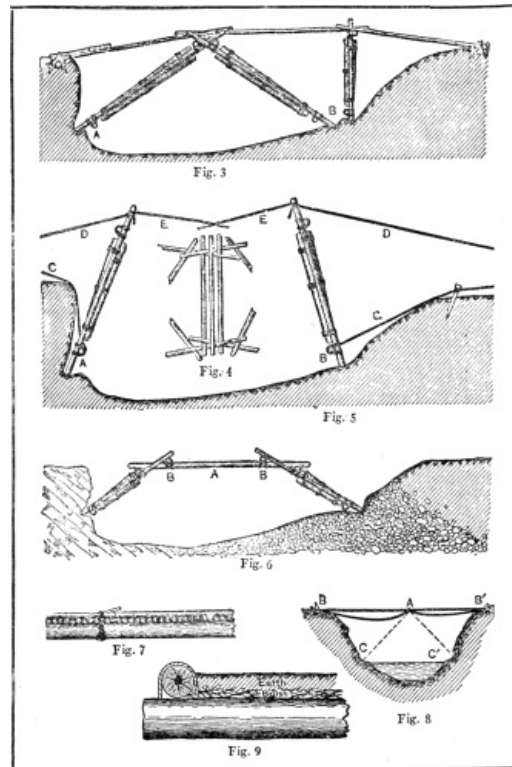

Plate I

1113. Construction of single-lock bridges, Figs. 3, 4, and 5.—Suitable for spans of 30 ft. or less. The two frames lock together at the center of the span; their slope must not be more than 4 on 7. The bridge can be erected by two or three noncommissioned officers and 20 men, one-half on each side of the gap. Heavy spars require more men.

[Pg 369]

[Pg 370]

The footings at *A* and *B* must be firm, horizontal if possible, and at right angles to the axis of the bridge. In a masonry pier they may be cut out. In firm soil a simple trench will suffice. In yielding soil a plank or sill must be laid in the trench. The frames are made of such length as to give a slight camber to the bridge, which may be increased to allow for probable settlement of the footings. The inside dimension of one frame is made slightly greater than the outside dimension of the other, so that one frame may fall inside of the other when hauled into position. For a 9 ft. roadway the standards of the narrow (inside) frame should be 9 ft. 6 ins. apart at the transom and 10 ft. 6 ins. at the ledger, in the clear, and the other (outside) frame 1 ft. 6 ins. wider throughout.

A frame is constructed on each bank. The standards are laid on the ground in prolongation of the bridge, butts toward the bank. The ledgers are lashed on *above* and the transoms *beneath* the standards at the positions marked. The diagonal braces are lashed to the standards, two butts and one tip above the latter, and to each other. Before the braces are lashed the frame must be square by checking the measurements of the diagonals.

If necessary, pickets for the foot and guy ropes are driven, the former about 2 paces from the bank and 4 paces on each side of the axis of the bridge; the latter about 20 paces from the bank and 10 paces on each side of the axis. The foot ropes, *CC*, Fig. 5, are secured by timber hitches to the butts of the standards and the back and fore guys, *DD* and *EE*, to the tips the fore guys are passed across to the opposite bank. The guys of the *narrow* frame should be *inside* the guys and standards of the wide frame.

The frames are put into position one after the other, or simultaneously if there are enough men. A man is told off to each foot rope and one to each back guy to slack off as required, two turns

being taken with each of these ropes around their respective pickets. The other men raise the frame and launch it forward, assisted by the men at the fore guys, until the frame is balanced on the edge of the bank. The frame is then tilted until the butts rest on the footing, by slacking off the foot ropes and hauling on the fore guys, [Fig. 5](#). After the head of the frame has been hauled over beyond the perpendicular, it is lowered nearly into its final position by slacking off the back guys. When the two frames are in this position opposite each other, the narrow frame is further lowered until its standards rest upon the transom of the other. The wider (outer) frame is then lowered until the two lock into each other, the standards of each resting upon the transom of the other.

The center or fork transom, [Figs. 3](#) and [4](#), is then passed from shore and placed in the fork between the two frames. This forms the central support to receive a floor system of two bays, built as already described.

The estimated time for construction of such a bridge is about one hour if the material is available and in position on both sides of the stream. The construction of the roadway requires about twenty minutes; forming footings in masonry about one hour.

1114. Construction of double-lock bridge, [Fig. 6](#).—Suitable for spans not exceeding 45 ft., and consisting of two inclined frames which lock into a connecting horizontal frame of two or more distance pieces, with cross transoms, dividing the gap to be bridged into three equal bays of about 15 ft. The force required is two or three noncommissioned officers and 25 to 50 men; the time for construction, except roadway, about two and one-half hours; extra time to be allowed for difficult footings.

[Pg 371]

The width of gap is measured, the position of footings determined, and the length of standards from butt to transom determined and marked as before.

The inclined frames in this case are built of equal widths, launched as before, and held by guys just above their final position. Two stringers are launched out from each bank to the main transom. The distance pieces, [Fig. 6](#), are put into position inside the standards, using tackle if necessary, and the road transoms are placed and lashed to the distance pieces at the places marked. Both frames are now lowered until they jam.

1115. Roadway of spar bridge.—For infantry in fours crowded the transoms should have a diam. of not less than 9 ins. for a span of 15 ft. Five stringers 2 ft. 3 ins. c. to c., and 6 ins. diam. at the tip will suffice. If the sticks vary in size, the larger ones should be notched down on the transom so as to bring the tops in the same plane. The stringers should be long enough to overlap the transoms, and should be lashed together at each tip. The floor is held down by side rails over the outside stringers and lashed to them. If lumber can not be obtained, a floor may be made, of small spars, the interstices filled with brush, and the whole covered with loam or clay; [Figs. 7](#) and [9](#).

Corduroy Roads

1116. Corduroying is done by laying logs crosswise of the road and touching each other. The result will be better if the logs are nearly of the same size. The butts and tips should alternate. If the logs are large the spaces may be filled with smaller poles. The bottom tier of logs should be evenly bedded and should have a firm bearing at the ends and not ride on the middle. The filling poles, if used, should be cut and trimmed to lie close, packing them about the ends if necessary. If the soil is only moderately soft the logs need be no longer than the width of the road. In soft marsh it may be necessary to make them longer.

The logs may be utilized as the wearing surface. In fact this is usually the case. They make a rough surface, uncomfortable for passengers and hard on wagons and loads, but the resistance to traction is much less than would be expected, and the roughness and slightly yielding surface make excellent footing for animals. Surface corduroy is perishable and can last but a short time. In marshes, where the logs can be placed below the ground-water level, they are preserved from decay, and if any suitable material can be found, to put a thin embankment over them, a good permanent road may be made.

Any tough, fibrous material may be used to temporarily harden the surface of a road. Hay or straw, tall weeds, corn and cane stalks have been used to good advantage. Such materials should be laid with the fibers crosswise of the road, and covered with a thin layer of earth, thrown on from the sides; except in sand, when it is better to dig a shallow trench across the road, fill it with the material and then dig another trench just in front of and in contact with the first and throw the sand from it back onto the material in the first trench, etc.

[Pg 372]

Brush work

1117. A fascine is a cylindrical bundle of brush, closely bound. The usual length is 18 ft. and the diam. 9 ins. when compressed. Lengths of 9 and 6 ft., which are sometimes used, are most conveniently obtained by sawing a standard fascine into 2 or 3 pieces. The weight of a fascine of partially seasoned material will average 140 lbs.

Fascines are made in a **cradle** which consists of five trestles. A **trestle** is made of two sticks about 6¹/₂ ft. long and 3 ins. in diam, driven into the ground and lashed at the intersection as shown in [Fig. 10](#). In making a cradle, plant the end trestles 16 ft. apart and parallel. Stretch a line from one to the other over the intersection, place the others 4 ft. apart and lash them so that each intersection comes fairly to the line.

To build a fascine, straight pieces of brush, 1 or 2 ins. at the butt, are laid on, the butts projecting at the end 1 ft. beyond the trestle. Leaves should be stripped and unruly branches cut off, or partially cut through, so that they will lie close. The larger straighter brush should be laid on the outside, butts alternating in direction, and smaller stuff in the center. The general object is to so dispose the brush as to make the fascine of uniform size, strength, and stiffness from end to end.

When the cradle is nearly filled, the fascine is compressed or **choked** by the **fascine choker**, [Fig. 11](#), which consists of 2 bars 4 ft. long, joined at 18 ins. from the ends by a chain 4 ft. long. The chain is marked at 14 ins. each way from the middle by inserting a ring or special link. To use, two men standing on opposite sides pass the chain under the brush, place the short ends of the handles on top and pass the bars, short end first, across to each other. They then bear down on the long ends until the marks on the chain come together. Chokers may be improvised from sticks and rope or wire.

Binding will be done with a double turn of wire or tarred rope. It should be done in 12 places, 18 ins. apart, the end binders 3 ins. outside the end trestles. To bind a fascine will require 66 ft. of wire.

Improvised binders may be made from rods of live brush, hickory or hazel is the best. Place the butt under the foot and twist the rod to partially separate the fibers and make it flexible. A rod so prepared is called a **withe**. To use a withe, make a half turn and twist at the smaller end, [Fig. 12](#); pass the withe around the brush and the large end through the eye. Draw taut and double the large end back, taking 2 half-hitches over its own standing part, [Fig. 13](#).

When the fascine is choked and bound, saw the ends off square, 9 ins. outside the end binders. After a cradle is made, 4 men can make 1 fascine per hour, with wire binding. Withes require 1 man more.

A **fascine revetment** is made by placing the fascines as shown in [Fig. 14](#). The use of headers and anchors is absolutely necessary in loose soils only, but they greatly strengthen the revetment in any case. A fascine revetment **must always be crowned** with sods or bags.

[Pg 373]

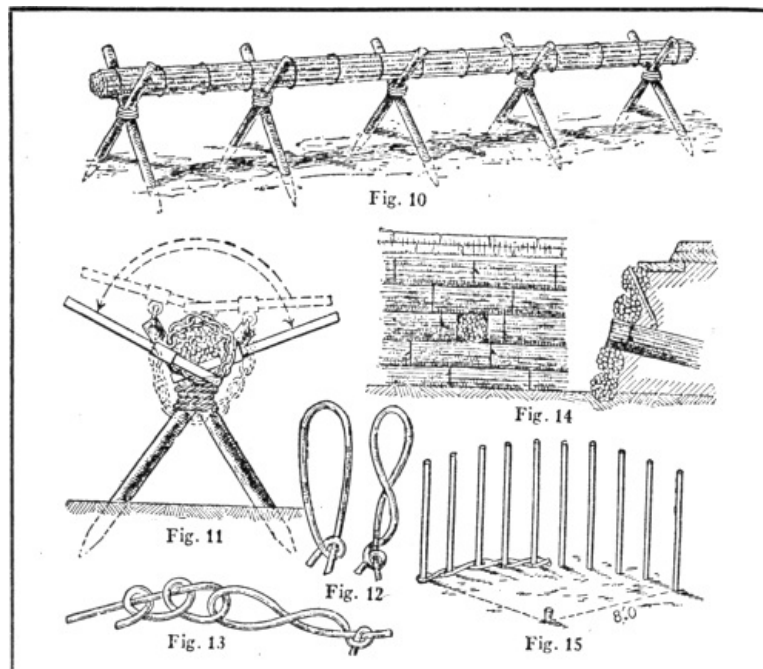

Plate II

1118. In all brush weaving the following terms have been adopted and are convenient to use:

Randing.—Weaving a single rod in and out between pickets.

Slewing.—Weaving two or more rods together in the same way.

Pairing.—Carrying two rods together, crossing each other in and out at each picket.

Wattling.—A general term applied to the woven part of brush construction.

1119. A **hurdle** is a basket work made of brushwood. If made in pieces, the usual size is 2 ft. 9 ins. by 6 ft., though the width may be varied so that it will cover the desired height of slope.

A hurdle is made by describing on the ground an arc of a circle of 8 ft. radius and on the arc driving 10 pickets, 8 ins. apart, covering 6 ft. out to out, [Fig. 15](#). Brush is then woven in and out and well compacted. The concave side of a hurdle should be placed next the earth. It wraps less than if made flat.

In weaving the hurdle, begin randing at the middle space at the bottom. Reaching the end, twist the rod as described for a withe, but at one point only, bend it around the end picket and work back. Start a second rod before the first one is quite out, slewing the two for a short distance. Hammer the wattling down snug on the pickets with a block of wood and continue until the top is reached. It improves the hurdle to finish the edges with two selected rods paired, [Fig. 16](#). A pairing may be introduced in the middle, if desired, to give the hurdle extra endurance if it is to be used as a pavement or floor. If the hurdle is not to be used at once, or if it is to be transported, it must be sewed. The sewing is done with wire, twine, or withes at each end and in the middle, with stitches about 6 ins. long, as shown in [Fig. 16](#). About 40 ft. of wire is required to sew one hurdle. No. 14 is about the right size, and a coil of 100 lbs. will sew 40 hurdles. Three men should make a hurdle in 2 hours, 2 wattling and the third preparing the rods.

1120. Continuous hurdle.—If conditions permit the revetment to be built in place, the hurdle is made continuous for considerable lengths. The pickets may be larger; they are driven farther apart, 12 or 18 ins., and the brush may be heavier. The construction is more rapid. The pickets are driven with a little more slant than is intended and must be anchored to the parapet. A line of poles with wire attached at intervals of 2 or 3 pickets will answer. The wires should be made fast to the pickets after the wattling is done. They will interfere with the wearing if fastened sooner. Two men should make 4 yds. of continuous hurdle of ordinary height in one hour.

1121. Brush revetment.—Pickets may be set as above described and the brush laid inside of them without weaving, being held in place by bringing the earth up with it. In this case the anchors must be fastened before the brush laying begins. The wires are not much in the way in this operation.

1122. Gabion making.—A **gabion** is a cylindrical basket with open ends, made of brush woven on pickets or stakes as described for hurdles. The usual size is 2 ft. outside diam. and 2 ft. 9 ins. height of wattling. On account of the sharp curvature somewhat better brush is required for gabions than will do for hurdles.

The gabion form, [Fig. 17](#), is of wood, 21 ins. diam., with equidistant notches around the circumference, equal in number to the number of pickets to be used, usually 8 to 14, less if the brush is large and stiff, more if it is small and pliable. The notches should be of such depth that the pickets will project to 1 in. outside the circle. The pickets should be $1\frac{1}{4}$ to $1\frac{3}{4}$ ins. diam., 3 ft. 6 ins. long and sharpened, half at the small and half at the large end.

To make a gabion, the form is placed on the ground, level or nearly so, and the pickets are driven vertically in the notches, large and small ends down, alternately. The form is then raised a foot and held by placing a lashing around outside the pickets, tightened with a rack stick, [Fig. 18](#). The wattling is randed or slewed from the form up. The form is then dropped down, the gabion inverted and the wattling completed. If the brush is small, uniform, and pliable, pairing will make a better wattling than randing. If not for immediate use, the gabion must be sewed as described for hurdles, the same quantity of wire being required.

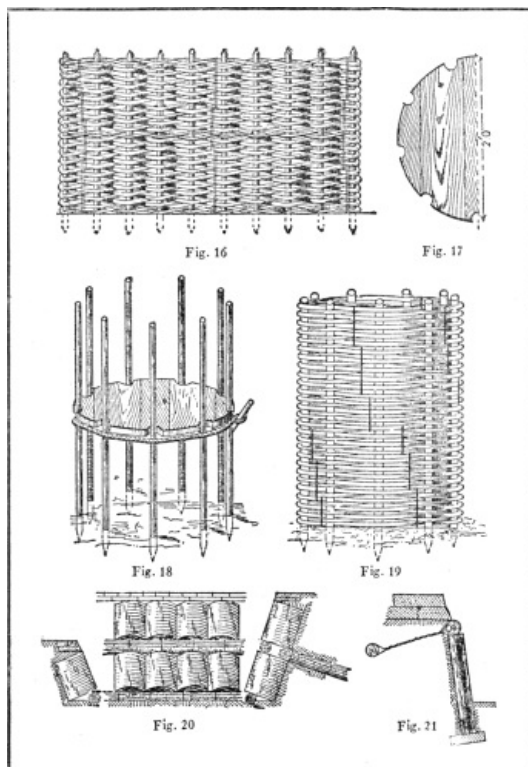

The gabion, when wattled and sewed, is completed by cutting off the tops of the pickets 1 in. from the web, the bottom 3 ins., the latter sharpened after cutting, and driving a carrying picket through the middle of its length and a little on side of the axis. See that the middle of this picket is smooth. Three men should make a gabion in an hour.

Gabions may be made without the forms, but the work is slower and not so good. The circle is struck on the ground and the pickets driven at the proper points. The weaving is done from the ground up and the entire time of one man is required to keep the pickets in proper position.

If brush is scarce, gabions may be made with 6 ins. of wattling at each end, the middle left open. In filling, the open part may be lined with straw, grass, brush cuttings, or grain sacks, to keep the earth from running out.

1123. Gabion revetment.—The use of gabions in revetments is illustrated in [Fig. 20](#). If more than two tiers are used, the separating fascines should be anchored back. Gabion revetments should be crowned with sods or bags.

The advantages of the gabion revetment are very great. It can be put in place without extra labor and faster and with less exposure than any other. It is self-supporting and gives cover from view and partial cover from fire quicker than any other form.

Several forms of gabions of other material than brush have been used. Sheet iron and iron and paper hoops are some of them. The iron splinters badly, is heavy, and has not given satisfaction. If any special materials are supplied the method of using them will, in view of the foregoing explanation, be obvious.

1124. Timber or pole revetment.—Poles too large for use in any other way may be cut to length and stood on end to form a revetment. The lower ends should be in a small trench and have a waling piece in front of them. There must also be a waling piece or cap at or near the top, anchored back. [Fig. 21](#) shows this form.

1125. Miscellaneous revetments.—Any receptacles for earth which will make a stable, compact pile, as **boxes, baskets, oil or other cans**, may be used for a revetment. **Barrels** may be used for gabions. **Canvas** stretched behind pickets is well thought of in a foreign service. If the soil will make **adobe**, or sun-dried bricks, an excellent revetment may be made of them, but it will not stand wet weather.

Knots

[Pg 377]



Fig. 22
Square or
Reef

1126. Square or reef knot, [Fig. 22](#), commonly used for joining two ropes of the same size. The standing and running parts of each rope must pass through the loop of the other in the same direction, i. e., from above down ward or vice versa; otherwise a *granny*, is made, which is a useless knot that will not hold. The reef knot can be upset by taking one end of the rope and its standing part and pulling them in opposite directions. With dry rope a reef knot is as strong as the rope; with wet rope it slips before the rope breaks, while a double sheet bend is found to hold.



Fig. 23
Two half
hitches

1127. Two half hitches, [Fig. 23](#), especially useful for belaying, or making fast the end of a rope round its own standing part. The end may be lashed down or seized to the standing part with a piece of spun yarn; this adds to its security and prevents slipping.

This knot should never be used for hoisting a spar.

1128. Clove hitch, [Fig. 24](#), generally used for fastening a rope at right angles to a spar or at the commencement of a lashing. If the end of the spar is free, the hitch is made by first forming two

loops, as in [Fig. 26](#), placing the right-hand loop over the other one and slipping the double loop ([Fig. 27](#)) over the end of the spar. If this can not be done, pass the end of the rope round the spar, bring it up to the right of the standing part, cross over the latter, make another turn round the spar, and bring up the end between the spar, the last turn, and the standing part, [Fig. 25](#). When used for securing guys to sheer legs, etc., the knot should be made with a long end, which is formed into two half hitches round the standing part and secured to it with spun yarn.

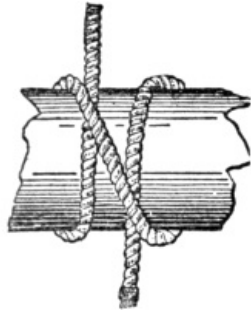

Fig. 24

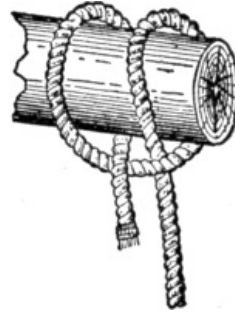

Fig. 25



Fig. 26



Fig. 27

Clove hitch

1129. Timber hitch, [Fig. 28](#), used for hauling and lifting spars. It can easily be loosed when the strain is taken off, but will not slip under a pull. When used for hauling spars, a half hitch is added near the end of the spar, [Fig. 29](#).

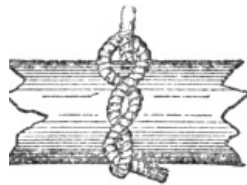

Fig. 28
Timber hitch

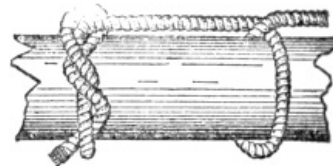

Fig. 29
Timber hitch and half hitch

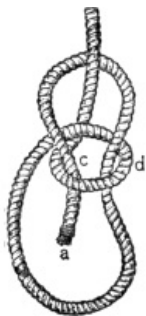

Fig. 30
Bowline

1130. Bowline, [Fig. 30](#), forms a loop that will not slip. Make loop with the standing part of the rope underneath, pass the end from below through the loop, over the part round the standing part of the rope, and then down through the loop *c*. The length of bight depends upon the purpose for which the knot is required.

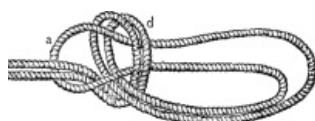

Fig. 31
Bowline on a Bight

1131. Bowline on a bight, [Fig. 31](#). The first part is made like the above, with the double part of a rope; then the bight *a* is pulled through sufficiently to allow it to be bent past *d* and come up in the position shown. It makes a more comfortable sling for a man than a single bight.

1132. Sheep shank, [Fig. 32](#), used for shortening a rope or to pass by a weak spot; a half hitch is taken with the standing parts around the bights.



Fig. 32
Sheep shank

1133. Short splice. To make a *short splice*, [Figs. 33, 34, 35](#), unlay the strands of each rope for a convenient length. Bring the rope ends together so that each strand of one rope lies between the two consecutive strands of the other rope. Draw the strands of the first rope along the second and grasp with one hand. Then work a free strand of the second rope over the nearest strand of the first rope and under the second strand, working in a direction opposite to the twist of the rope. The same operation applied to all the strands will give the result shown by [Fig. 34](#). The splicing may be continued in the same manner to any extent ([Fig. 35](#)) and the free ends of the strands may be cut off when desired. The splice may be neatly tapered by cutting out a few fibers from each strand each time it is passed through the rope. Rolling under a board or the foot will make the splice compact.

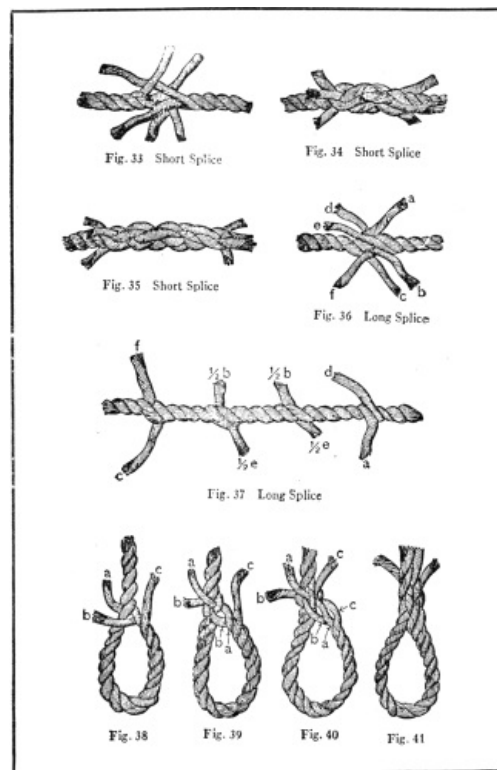

Plate IV

1134. Long splice ([Figs. 36, 37](#)).—Unlay the strands of each rope for a convenient length and bring together as for a short splice. Unlay to any desired length a strand, *d*, of one rope, laying in its place the nearest strand, *a*, of the other rope. Repeat the operation in the opposite direction with two other strands, *c* and *f*. [Fig. 37](#) shows strands *c* and *f* secured by tying together. Strands *b* and *e* are shown secured by unlaying half of each for a suitable length and laying half of the other in place of the unlayed portions, the loose ends being passed through the rope. This splice is used when the rope is to run through a block. The diameter of the rope is not enlarged at the splice. The ends of the strands should not be trimmed off close until the splice has been thoroughly stretched by work.

1135. Eye splice ([Figs. 38, 39, 40, 41](#)).—Unlay a convenient length of rope. Pass one loose strand, *a*, under one strand of the rope, as shown in [fig. 38](#), forming an eye of the proper size. Pass a second loose strand, *b*, under the strand of the rope next to the strand which secures *a*, [Fig. 39](#). Pass the third strand, *c*, under the strand next to that which secures *b*, [fig. 40](#). Draw all taut and continue and complete as for a short splice.

Lashings

1136. To lash a transom to an upright spar, [Fig. 42](#), transom in front of upright.—A clove hitch is made round the upright a few inches below the transom. The lashing is brought under the transom, up in front of it, horizontally behind the upright, down in front of the transom, and back behind the upright at the level of the bottom of the transom and above the clove hitch. The

following turns are kept outside the previous ones on one spar and inside on the other, not riding over the turns already made. Four turns or more are required. A couple of frapping turns are then taken between the spars, around the lashing, and the lashing is finished off either round one of the spars or any part of the lashing through which the rope can be passed. The final clove hitch should never be made around the spar on the side toward which the stress is to come, as it may jam and be difficult to remove. The lashing must be well beaten with handspike or pick handle to tighten it up. This is called a square shears are laid alongside of each other with their butts on the ground, lashing.

1137. Lashing for a pair of shears, Fig. 43.—The two spars for the points below where the lashing is to be resting on a skid. A clove hitch is made round one spar and the lashing taken loosely eight or nine times about the two spars above it without riding. A couple of frapping turns are then taken between the spars and the lashing is finished off with a clove hitch above the turns on one of the spars. The butts of the spars are then opened out and a sling passed over the fork, to which the block is hooked or lashed, and fore and back guys are made fast with clove hitches to the bottom and top spars, respectively, just above the distance from the butt to the center of the lashing. Lay two of the spars parallel to each other with an interval a little greater fork, Fig. 44.

1138. To lash three spars together as for a gin or tripod.—Mark on than the diameter. Rest their tips on a skid and lay the third spar between them with its butt in the opposite direction so that the marks on the three spars will be in line. Make a clove hitch on one of the outer spars below the lashing and take eight or nine loose turns around the three, as shown in Fig. 45. Take a couple of frapping turns between each pair of spars in succession and finish with a clove hitch on the central spar above the lashing. Pass a sling over the lashing and the tripod is ready for raising.

1139. Holdfasts.—To prepare a fastening in the ground for the attachment of guys or purchases, stout pickets are driven into the ground one behind the other, in the line of pull. The head of each picket except the last is secured by a lashing to the foot of the picket next behind, Fig. 46. The lashings are tightened by rack sticks, the points of which are driven into the ground to hold them in position. The distance between the stakes should be several times the height of the stake above the ground.

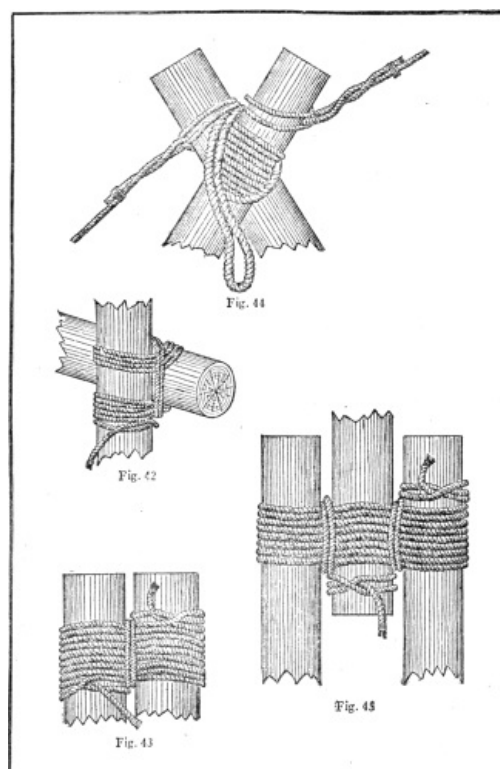

Plate V

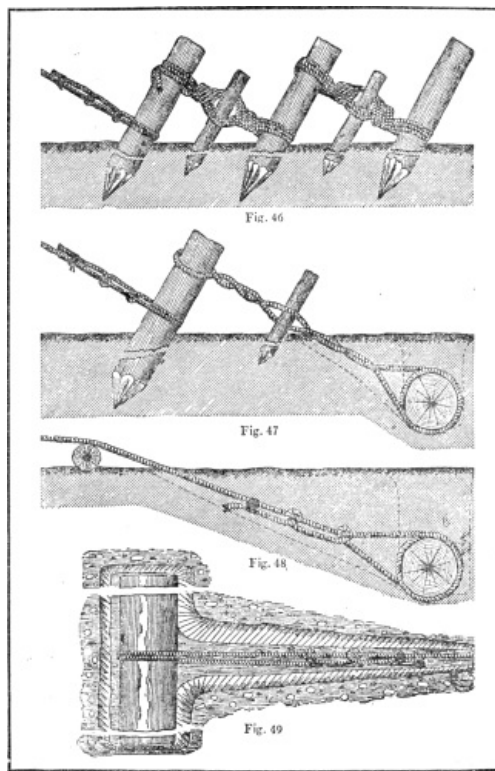

Plate VI

Another form requiring more labor but having much greater strength is called a "deadman," and consists of a log laid in a transverse trench with an inclined trench intersecting it at its middle point. The cable is passed down the inclined trench, takes several round turns on the log, and is fastened to it by half hitches and marlin stopping, [Figs. 47, 48, 49](#). If the cable is to lead horizontally or inclined downward, it should pass over a log at the outlet of the inclined trench, [Fig. 48](#). If the cable is to lead upward, this log is not necessary, but the anchor log must be buried deeper.

[Pg 384]

CHAPTER X

[Pg 385]

FIELD FORTIFICATIONS

1140. Object. The object of field fortifications is two-fold.

1. To increase the fighting power of troops by enabling the soldier to use his weapons with the greatest possible effect.
2. To protect the soldier against the enemy's fire.

1141. How these objects are accomplished.

These objects are accomplished:

1. By means of shelters—trenches, redoubts, splinterproofs, etc., which protect the soldier from the enemy's fire.
2. By means of obstacles—wire entanglements, abatis, pits, etc., which delay the advance of the enemy.

1142. Classification. Field fortifications are usually divided into three classes, **hasty intrenchments, deliberate intrenchments** and **siege works**.

Nomenclature of the Trench. The following illustration shows the names of the various parts of the trench.

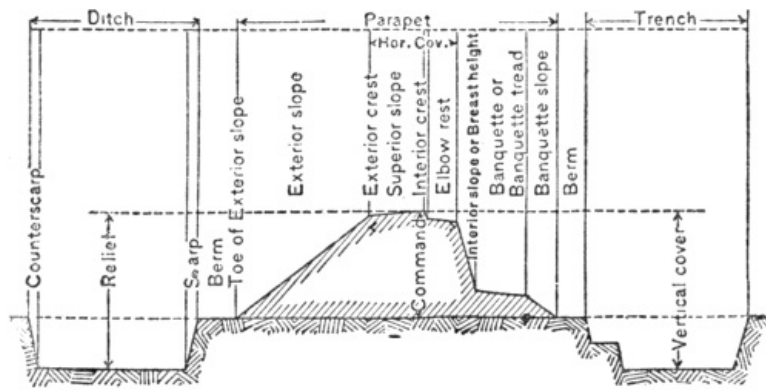

Fig. 1

1143. Hasty intrenchments include trenches dug by troops upon the battlefield to increase their fighting power. They are usually constructed in the presence of the enemy and in haste and embrace three forms viz:—the **lying trench**, the **kneeling trench**, and the **standing trench**.

1144. Lying trench. (Fig. 2.) This trench gives cover to a man lying down. When intrenching under fire the rifle trench can be constructed by a man lying down. He can mask himself from view in about 10 to 12 minutes and can complete the trench in 40 to 45 minutes. A good method is to dig a trench 18 inches wide back to his knees, roll into it and dig 12 inches wide alongside of it and down to the feet, then roll into the second cut and extend the first one back. Conditions may require men to work in pairs, one firing while the other uses his intrenching tool. Duties are exchanged from time to time until the trench is completed.

[Pg 386]

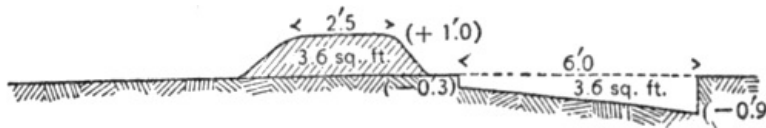

Fig. 2



Fig. 2a
Intrenching under fire

The height of the parapet should not exceed 1 foot. This trench affords limited protection against rifle fire and less against shrapnel.

1145. Kneeling trench. (Fig. 3.) Time permitting the lying trench may be enlarged and deepened until the kneeling trench has been constructed. The width of the bottom should be 2½ feet—preferably 3 feet—and the relief (distance from bottom of trench to top of parapet) is 3 feet—the proper height for firing over in a kneeling position.

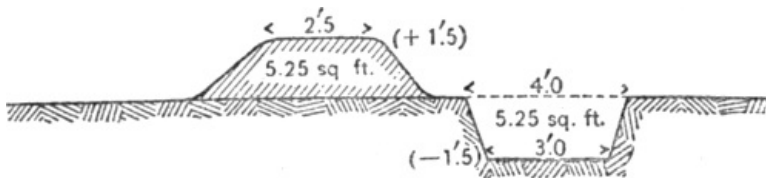

Fig. 3

1146. Standing trench (Fig. 4) has a bottom width of 3 to 3½ feet and a relief of 4½ feet which is the proper firing height for men of average stature. As this trench does not give complete cover to men standing in it a passage way should be constructed in rear of it not less than 6 feet below the interior crest. This forms the complete trench (Fig. 5). Figures 6-7-8 show simple standing trenches used in the European War.

[Pg 387]

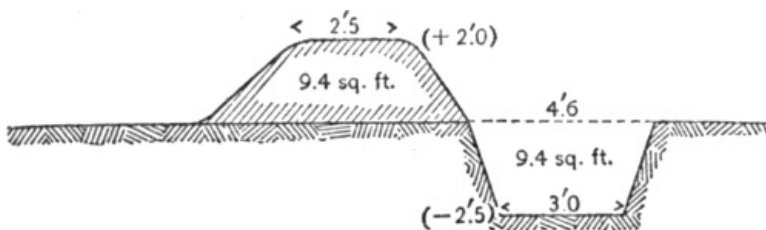

Fig. 4

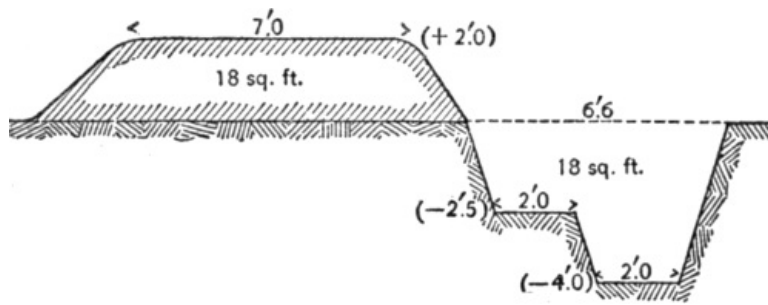

Fig. 5

Simple Standing Trench, Parapet Suppressed

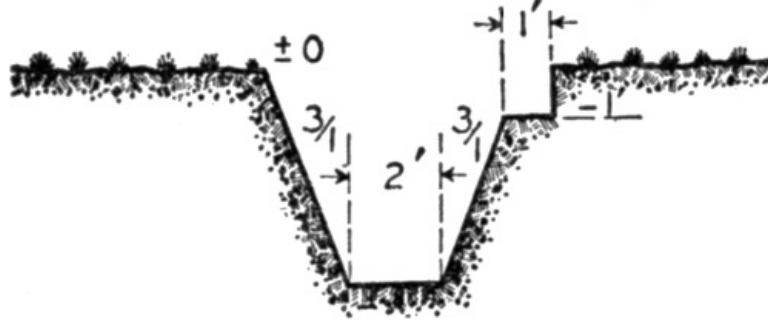

Fig. 6

Simple Standing Trench, Rocky Ground

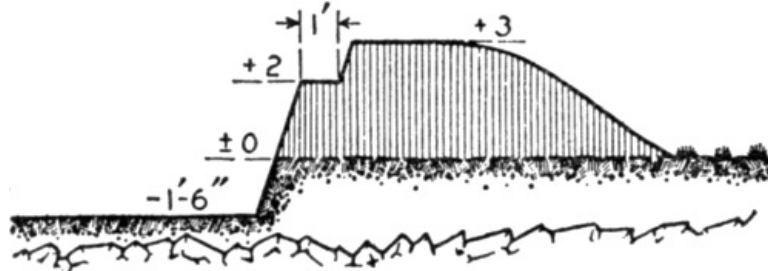

Fig. 7

Narrow Firing Trench with Parados

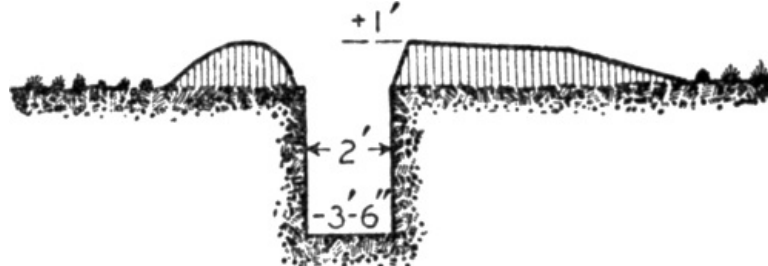

Fig. 8

1147. Deliberate intrenchments comprise trenches and works constructed by troops not in line of battle and are usually intended to enable a small force to resist a much larger one. It frequently happens that hasty intrenchments are developed into deliberate intrenchments and from this stage pass into the domain of siege works.

1148. Fire trenches,—the trenches which shelter the firing line,—are of different types. No fixed type can be prescribed. The type must be selected with due regard to the terrain, enemy, time, tools, soil, etc., but all should conform to the requirements of a good field of fire, and protection for the troops behind a vertical wall, preferably with some head or over head cover.

The simplest form of fire trench is deep and narrow and has a flat concealed parapet (Fig. 9). When time will permit the simple trench should be planned with a view to developing it into a more complete form (Figs. 10 and 11). In all trenches as soon as practicable a passage way—2 feet wide at the bottom—should be provided, in rear of the firing step, for the men carrying supplies, ammunition, etc., and for the removal of the wounded.

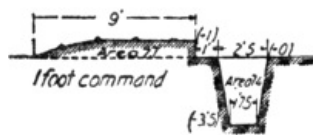

Fig. 9

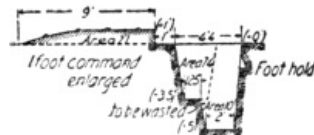

Fig. 10

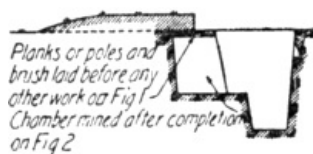

Fig. 11

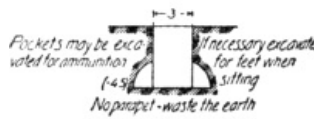

Fig. 12

When the excavated earth is easily removed a fire trench without parapet may be the one best suited to the soil and other conditions affecting the conditions of profile (Fig. 12). The enemy's infantry as well as artillery will generally have great difficulty in seeing this trench. Fig. 13 shows a squad trench. Fig. 14 shows a fire trench provided with protection against shrapnel. This trench is used in the European War.

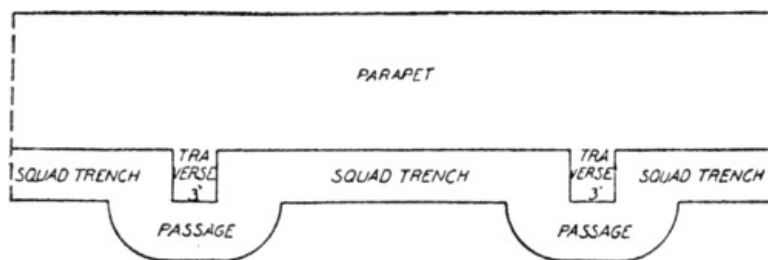

Fig. 13

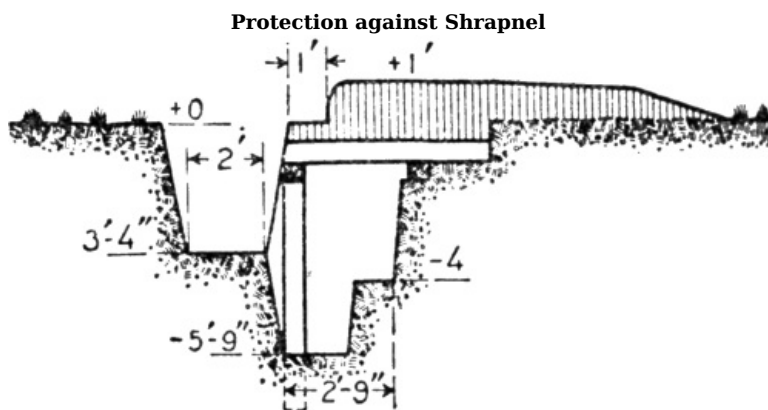

Fig. 14

In the European War the aim in constructing fire trenches seems to be to minimize and localize artillery effect as far as possible. The main excavation along the front is a continuous, very deep, communication, not in itself prepared for active defense. The actual firing is done from banquettes or firing steps just to the front of the passage or from trenches dug as far as 5 or 10 feet in front of the main excavation and reached by short passages. Figs 15 and 16 show the type of this construction. Fig. 17 shows a fire trench with parapets and shelter.

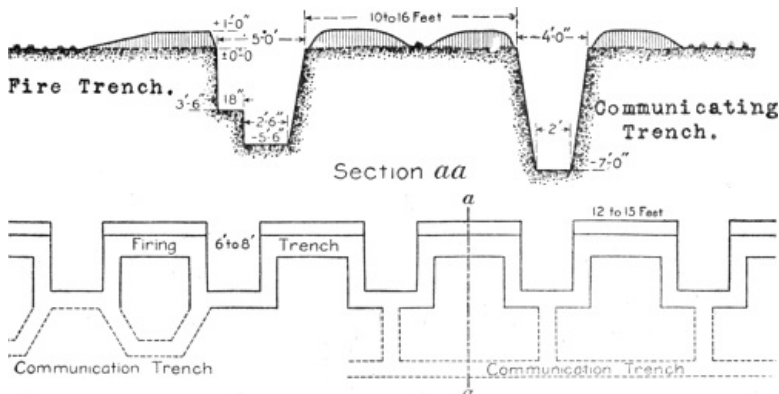
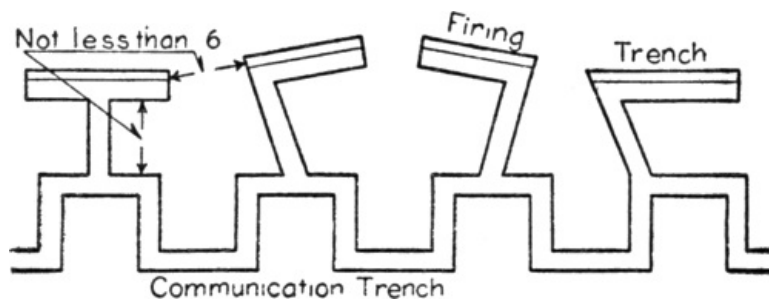
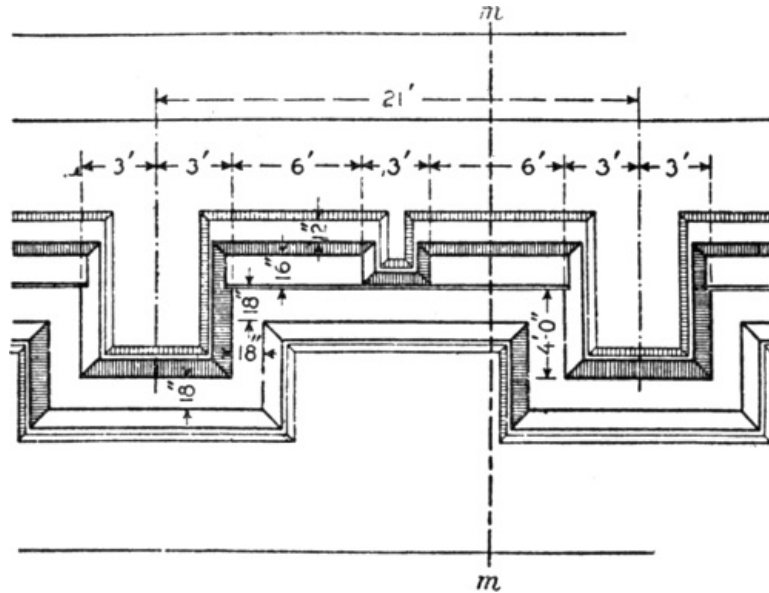

Fig. 15

Two Methods for Communication Trenches in rear of Firing Trenches



Communication Trenches in rear of Firing Trenches



Plan

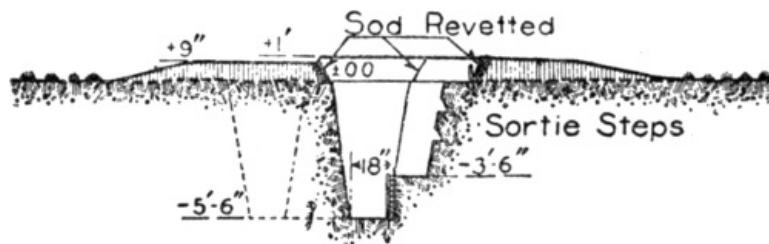

Section *m m*

Recessed and Traversed Firing Trench

Fig. 16

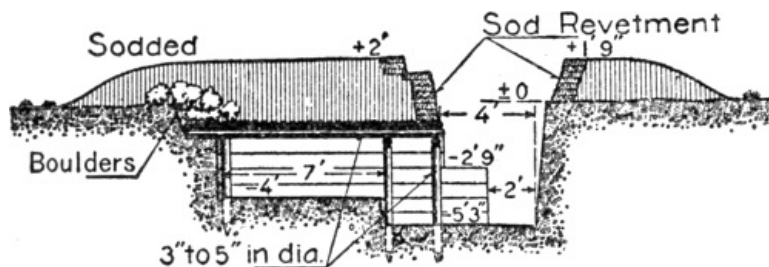

Fig. 17

Trench Shelter

1149. Traverses. Fire trenches are divided into sections or bays by means of traverses which intercept side or enfilade fire and limit the effect of shells, bombs or grenades, which burst inside of the trench. The traverses should be wide enough to screen the full width of the trench with a little to spare. The thickness of the traverse varies from 3 to 6 feet or more. Six feet is the dimension generally found in the traverses in the trenches on the European battle fronts.

1150. Trench recesses; sortie steps. It will be noted that in some of the diagrams of the trenches now being used in the European War the berm has been eliminated entirely. The object being to bring the firer closer to the vertical wall thus giving him better protection from shrapnel fire. There have also been added to the trench, recesses for hand grenades. These recesses are similar to recesses dug in the front wall of the trench for ammunition. One form of recess is shown in (Fig. 18). In order to provide facilities for rapidly mounting from the trench to charge,

sortie steps and stakes have been provided in some trenches as shown in (Fig. 16).

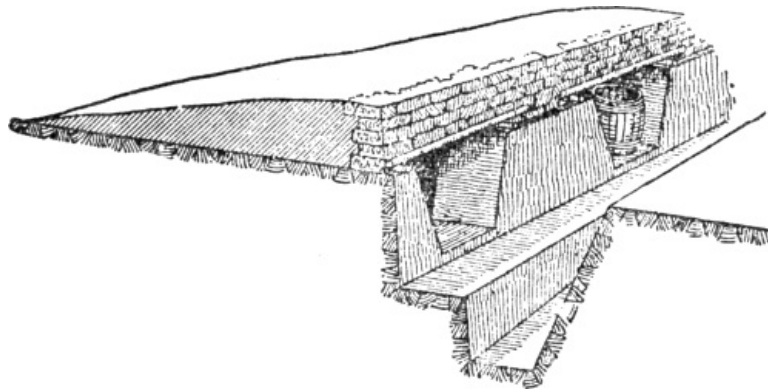

Fig. 18
Store Recesses for Water, Hand-Grenades, Reserve Ammunition, Machine Guns, Range Finders, Blankets, etc. (From Field Entrenchments—Solano.)

1151. Parados. Instead of shrapnel, explosive shell is most frequently used in the European War. This necessitates the addition of a parados to the fire trench to protect against the back blast of high explosives. This is shown in (Figs. 8 and 17).

[Pg 392]

An interesting development in cover for the firing line is shown in dugouts constructed in the fire trenches in the European war. These dugouts are deep underground and shelter from 3 to 8 men each (Fig. 19). These dugouts will be discussed more in length under cover trenches.

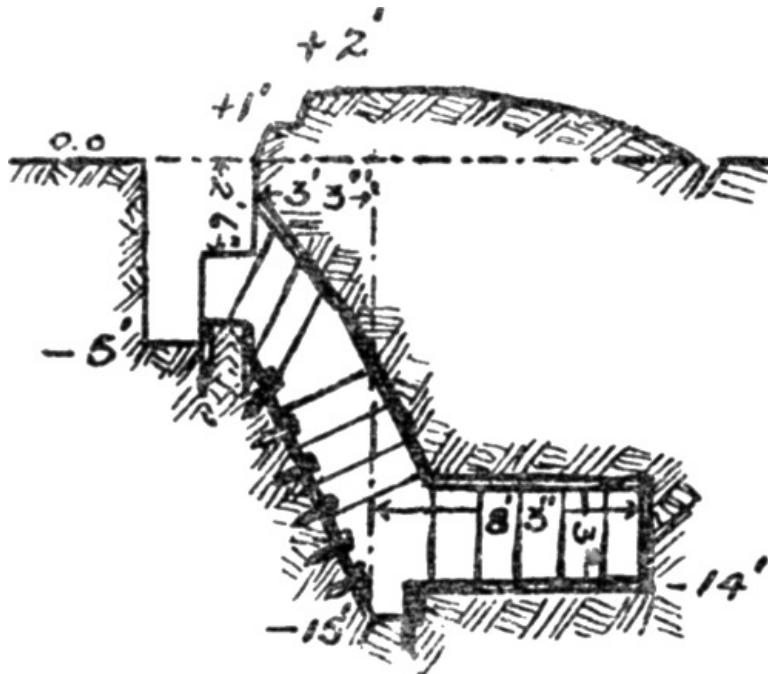

Fig. 19

1152. Head cover is the term applied to any horizontal cover which may be provided above the plane of fire. It is obtained by notching or loop-holing the top of the parapet so that the bottoms of the notches or loopholes are in the desired plane of fire. The extra height of parapet may be 12 to 18 inches and the loopholes may be 3 to 3½ feet center to center.

Head cover is of limited utility. It increases the visibility of the parapet and restricts the field of fire. At close range the loopholes serve as aiming points to steady the enemy's fire and may do more harm than good at longer ranges. This is especially the case if the enemy can see any light through the loophole. He waits for the light to be obscured, when he fires, knowing there is a man's head behind the loophole. A background must be provided or a removable screen arranged so that there will be no difference in the appearance of the loophole whether a man is looking through it or not. Head cover is advantageous only when the conditions of the foreground are such that the enemy can not get close up.

1153. Notches and loopholes, Figs. 20-22, are alike in all respects, except that the latter have a roof or top and the former have not. The bottom, also called **floor** or **sole**, is a part of the original superior slope. The sides, sometimes called **cheeks**, are vertical or nearly so. The plan depends upon local conditions. There is always a narrow part, called the **throat**, which is just large enough to take the rifle and permit sighting. From the throat the sides diverge at an angle, called the **splay**, which depends upon the field of fire necessary.

[Pg 393]

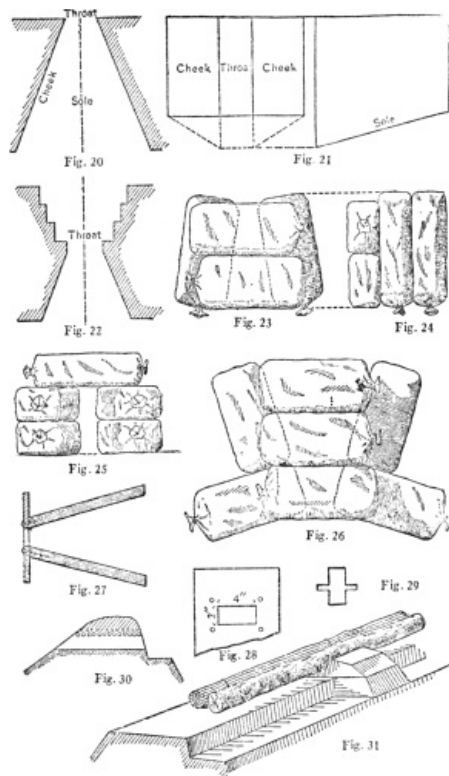

The position of the throat may vary. If on the outside, it is less conspicuous but more easily obstructed by injury to the parapet and more difficult to use, since in changing aim laterally the man must move around a pivot in the plane of the throat. If the material of which the loophole is constructed presents hard surfaces, the throat should be outside, notwithstanding the disadvantages of that position, or else the sides must be stepped as in [Fig. 22](#). In some cases it may be best to adopt a compromise position and put the throat in the middle, [Fig. 22](#). [Figs. 23](#) to [26](#) show details and dimensions of a loophole of sand bags.

[Pg 394]

A serviceable form of loophole consists of a pyramidal box of plank with a steel plate spiked across the small end and pierced for fire. [Fig. 27](#) shows a section of such a construction. It is commonly known as the **hopper loophole**. The plate should be $\frac{3}{8}$ in. thick, if of special steel; or $\frac{1}{2}$ in., if ordinary metal. [Fig. 28](#) shows the opening used by the Japanese in Manchuria and [Fig. 29](#) that used by the Russians.

The construction of a notch requires only the introduction of some available rigid material to form the sides; by adding a cover the notch becomes a loophole. Where the fire involves a wide lateral and small vertical angle, loopholes may take the form of a long slit. Such a form will result from laying logs or fascines lengthwise on the parapet, supported at intervals by sods or other material, [Fig. 31](#), or small poles covered with earth may be used, [Fig. 30](#).

1154. Overhead cover. This usually consists of a raised platform of some kind covered with earth. It is frequently combined with horizontal cover in a single structure, which protects the top and exposed side. The supporting platform will almost always be of wood and may vary from brushwood or light poles to heavy timbers and plank. It is better, especially with brush or poles, to place a layer of sods, grass down, or straw, or grain sacks over the platform before putting on the earth, to prevent the latter from sifting through.

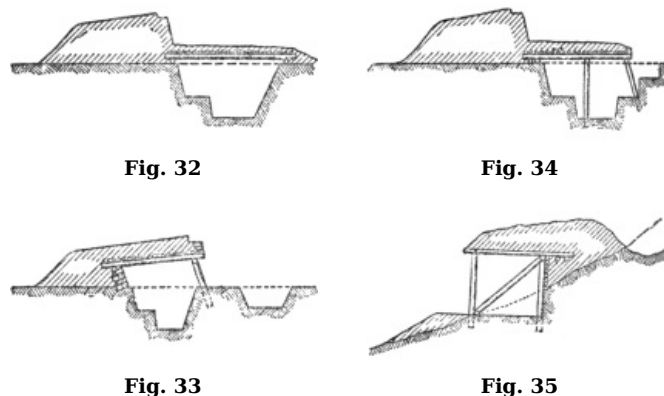

Types of overhead cover.

The thickness of overhead cover depends upon the class of fire against which protection is desired, and is sometimes limited by the vertical space available, since it must afford headroom beneath, and generally should not project above the nearest natural or artificial horizontal cover. For splinter proofs a layer of earth 6 to 8 ins. thick on a support of brush or poles strong enough to hold it up will suffice if the structure is horizontal. If the front is higher than the rear, less

thickness is necessary; if the rear is higher than the front, more is required. For bombproofs a minimum thickness of 6 ins. of timber and 3 ft. of earth is necessary against field and siege guns, or 12 ins. timber and 6 ft. of earth against the howitzers and mortars of a heavy siege train, not exceeding 6 inches in caliber.

In determining the area of overhead cover to be provided, allow 6 sq. ft. per man for occupancy while on duty only, or 12 sq. ft. per man for continuous occupancy not of long duration. For long occupation 18 to 20 sq. ft. per man should be provided.

It is not practicable to give complete cover to rifle positions that will successfully withstand the heavy artillery of today. The use of overhead cover is usually limited to that sufficient for protection against rifle fire, machine gun fire, and shrapnel.

1155. Cover trenches are constructed to provide safe cover for the supports or reinforcements of the fire trenches or to provide cooking and resting facilities for the garrison of the neighboring fire trenches. The important point in cover trenches is safety. They vary in design from the simple rectangular trenches to elaborately constructed trenches having overhead cover, kitchens, shelters, latrines, dressing stations, etc. Cover trenches must not be mistaken for a secondary position, they are cover for the firing line, supports and reserves until they are required in the fire trenches. The cover trench requires a depth of at least 6 feet to protect men standing. Greater depths may be used when necessary. [Fig. 36](#) is a section of an open cover trench and [Fig. 37](#) of a closed one. This section may be used for a communicating trench. [Fig. 38](#) shows a cover trench close to a fire trench. The character of overhead cover for trenches is shown in the diagrams under overhead cover. The distance of the cover trenches varies with the situation. The experience of the European war places the cover trenches from 15 to 50 yards in rear of the fire trenches. These trenches furnish shelter for at least $\frac{2}{3}$ of the firing line and supports.

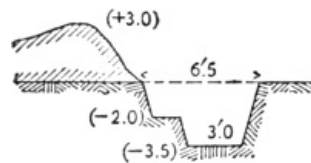

Fig. 36

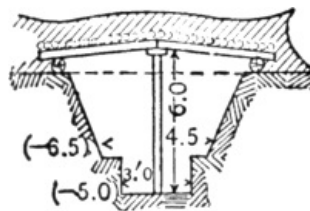

Fig. 37



Fig. 38

The reserves are furnished yet more elaborate shelter, with plenty of room for the men to lie down and rest and when practicable, bathing facilities are provided.

1156. Dugouts. An elaborate system of dugouts has developed along the lines occupied by the troops in the European war. These dugouts are located from 14 to 40 feet below the ground and are reached by stairs in timbered passage ways. At the foot of the stairs a tunnel or corridor runs forward and on either side or at the end, rooms have been dug out varying in size. Most of these rooms have been timbered and lined. Many are electrically lighted. In some of these underground shelters, accommodations for several hundred men have been prepared with all of the necessary facilities for making them comfortable. It must be understood that such elaborate preparations can only be made when troops face each other in trenches where operations have developed into practically a siege.

1157. Communicating trenches. These trenches as the name implies are for the purpose of providing safe communication between the cover and fire trenches. They may be also constructed just in rear of a series of fire trenches to provide a means of communication from one to the other. Communicating trenches also extend to the rear of the cover trenches and provide safe passage to fresh troops or supplies. These trenches are usually laid out in zig zag or curved lines ([Fig. 39](#)), to prevent enfilade fire from sweeping them. As a general rule excavated earth is placed on both sides of the trench to afford protection, the depth is usually from 6 to 7 feet. ([Fig. 15](#)) shows a typical communicating trench.

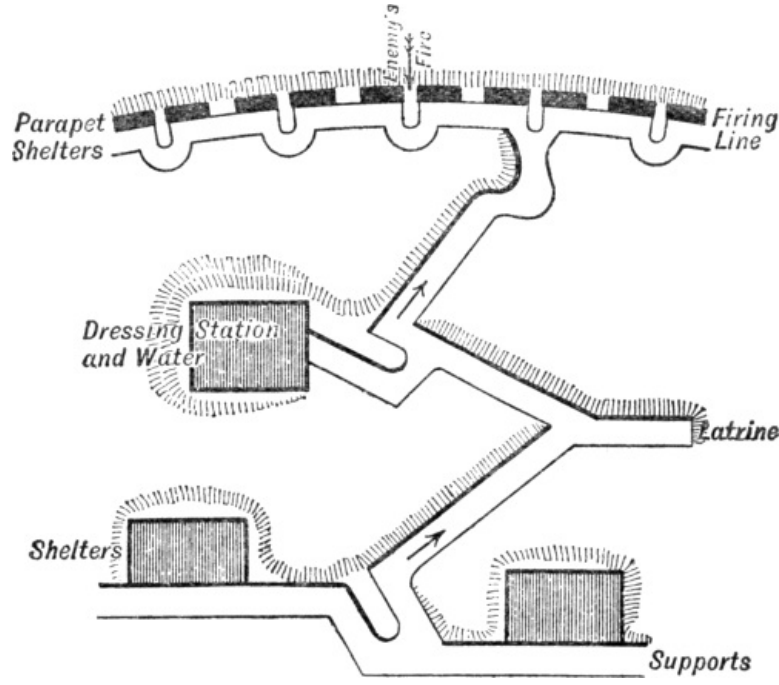

Fig. 39
Typical Passage Trench from Supports to Firing Line.
(From *Field Entrenchments*—Solano)

1158. Lookouts. To enable the garrison of a trench to get the greatest amount of comfort and rest, a *lookout* should be constructed and a sentinel stationed therein.

The simplest form would consist of two sandbags placed on the parapet and splayed so as to give the required view, and carefully concealed.

Better forms may be constructed, with one side resting on the berm by using short uprights with overhead cover, a slit on all sides being provided for observation.

[Pg 397]

At night, lookouts are usually posted at listening points located in or beyond the line of obstacles. These will be discussed under obstacles.

1159. Supporting Points. In some cases small supporting points may have to be established close behind the general line of trenches for the purpose of breaking up a successful attack on the trenches and to aid in delivering a counter attack. These points are strongly entrenched and have all around wire entanglements and are garrisoned by from 20 to 40 picked men or by larger forces if the situation demand it. In some cases machine guns are added to the force in the supporting point.

1160. Example of trench system. Having discussed trenches and obstacles somewhat in detail, let us take a combination of the whole showing a complete system such as is used today. (Fig. 40) is a good example.

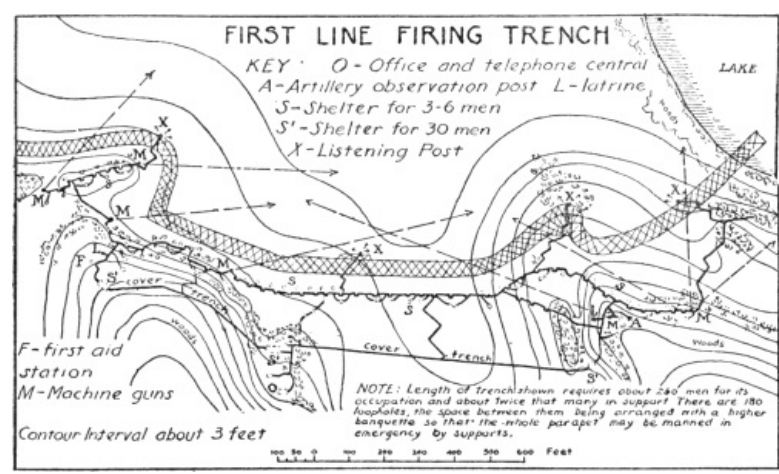

Fig. 40 (click to enlarge)

Beginning at the front we have the line of wire entanglements or obstacles with their listening posts X, for guarding them. Connecting the listening posts to the fire trenches are the communicating trenches. The fire trenches are shown by the heavy black line running about 60 feet in rear of the obstacles. Note the many traverses shown by the indentations in the line. Points marked M with arrows projecting to the flanks are machine guns, so located as to sweep the front of the position with a cross fire. Points marked S are underground shelters for from 3 to 6 men. Points marked S' are shelters for 30 men. In rear of the firing trenches at a distance varying from 100 to 200 feet is the line of cover trenches. This line is connected with the fire

[Pg 398]

trenches by the zig zagged line of communicating trenches. Note that the latrines (L) and first aid stations (F) are just off from the communicating trenches, while the larger shelter for men (S') are near the cover trenches. As the note on the diagram shows, the trench requires 250 men to occupy it with double that number in support. The trench has 108 loopholes with spaces between provided with a higher banquette so that the whole parapet may be manned for firing.

On the battlefields of Europe today there are generally three lines of fire trenches. This permits the defender to fall back to a 2nd or 3rd prepared position in case he is driven out of his first trench. On a hill we find a fire trench near the foot of the slope, one just forward of the military crest, and the third on the reverse slope of the hill.

In many instances the first line trenches consist of as many as four or five lines of trenches running in a general lateral direction and connected by deep narrow communicating trenches. The depth between the first and last of these trenches is, in some instances, not over a hundred yards. Sign boards are necessary at short intervals to prevent the soldiers from getting lost. The effect of having so many alternative firing trenches is to make it extremely difficult for an enemy to advance from, or even to hold one of them, even when he gains a footing, as he would be swept by fire from the supporting trenches in rear and also by flanking fire from the adjacent trenches.

1161. Location. There are two things to be considered in locating trenches: (1) The tactical situation, and (2) the nature of the ground. The first consideration requires that the trenches be so located as to give the best field of fire. Locating near the base of hills possesses the advantage of horizontal fire, but, as a rule, it is difficult to support trenches so located and to retreat therefrom in case of necessity. While location near the crest of hills—on the "military crest"—does not possess the advantage of horizontal fire, it is easier to support trenches so located and to retreat therefrom. Depending upon circumstances, there are times when it will be better to intrench near the base of hills and there are other times when it will be better to intrench on the "military crest," which is always in front of the natural crest. The construction of trenches along the "military crest" does not give any "dead space"—that is, any space to the front that can not be reached by the fire of the men in the trenches.

Whether we should construct our trenches on high or low ground is a matter that should always be carefully considered under the particular conditions that happen to exist at that particular time, and the matter may be summarized as follows:

The advantages of the high ground are:—

1. We can generally see better what is going on to our front and flanks; and the men have a feeling of security that they do not enjoy on low ground.
2. We can usually reënforce the firing line better and the dead and wounded can be removed more easily.
3. The line of retreat is better.

The disadvantages are:—

1. The plunging fire of a high position is not as effective as a sweeping fire of a low one.
2. It is not as easy to conceal our position.

The advantages of low ground, are:—

1. The low, sweeping fire that we get, especially when the ground in front is fairly flat and the view over the greater part of it is uninterrupted, is the most effective kind of fire.
2. As a rule it is easier to conceal trenches on low ground, especially from artillery fire.
3. If our trenches are on low ground, our artillery will be able to find good positions on the hill behind us without interfering with the infantry defense.

The disadvantages are:—

1. As a rule it will be more difficult to reënforce the firing line and to remove the dead and wounded from the trenches.
2. On a low position there will usually be an increase of dead space in our front.
3. The average soldier acting on the defensive dreads that the enemy may turn his flank, and this feeling is much more pronounced on low ground than on high ground. Should the enemy succeed in getting a footing on our flank with our trenches on top of the hill, it would be bad enough, but it would certainly be far worse if he got a footing on top of the hill, on the flank and rear, with our company on low ground in front. We, therefore, see there are things to be said for and against both high and low ground, and the most that can be said without examining a particular piece of ground is: Our natural inclination is to select high ground, but, as a rule, this choice will reduce our fire effect, and if there is a covered approach to our fire trenches and very little dead ground in front of it, with an extensive field of fire, there is no doubt the lower ground is better. However, if these conditions do not exist to a considerable degree, the moral advantage of the

higher ground must be given great weight, especially in a close country.

The experience of the European war emphasizes the fact that the location of rifle trenches is today, just as much as ever, a matter of compromise to be determined by sound judgment on the part of the responsible officers. The siting of trenches so that they are not under artillery observation is a matter of great importance, but, it has yet to be proven that this requirement is more important than an extensive field of fire. There are many instances where to escape observation and fire from the artillery, trenches were located on the reverse slopes, giving only a limited field of fire. This restricted field of fire permitted the enemy to approach within a few hundred yards of the trench and robbed them of the concealment they had hoped to gain. The choice between a site in front, and one in rear of a crest, is influenced by local conditions which govern the effectiveness of our own and the enemy's fire. In general, the best location for effective fire trenches, lies between the military crest of rising ground and the lowest line from which the foreground is visible. If the position on the military crest is conspicuous, it is inadvisable.

With regard to the nature of the ground, trenches should, if practicable, be so located as to avoid stony ground, because of the difficult work entailed and of the danger of flying fragments, should the parapet be struck by an artillery projectile.

[Pg 400]

To locate the trace of the trenches, lie on the ground at intervals and select the best field of fire consistent with the requirements of the situation.

Trenches should be laid out in company lengths, if possible, and adjoining trenches should afford each other mutual support. The flanks and important gaps in the line should be protected by fire trenches echeloned in rear.

1162. Concealment of trenches. Owing to the facilities for observation that the aeroplanes and other air craft afford, and to the accuracy and effect of modern artillery fire, every possible means should be taken to conceal trenches, gun placements, and other works. The aim should be to alter the natural surface of the ground as little as possible and to present a target of the smallest possible dimensions. Covering the parapet with brush or grass will afford temporary concealment. If the new earth can be sodded it aids greatly in concealing the trench. In some cases troops have gone to the extent of painting canvas to resemble the ground and have placed it over trenches, guns, etc. Straw and grass placed in the bottom of trenches make them less conspicuous to air scouts. When trenches are dug on a fairly steep slope care must be used to conceal the back of the trench, which, being higher than the parapet, will stand out as a scar on the hillside. Grass or brush may be used to conceal the back of the trench.

1163. Dummy trenches. May be constructed which attract the enemy's attention and draw his fire, or at least a part of it. The extent to which this method may be used may include the construction of dummy obstacles and guns, and even hats may be placed on the parapets.

1164. Length of trench. The usual minimum allowance of trench space is one yard per man, although in some tests, two feet was found sufficient for men to fire satisfactorily. Ordinarily one squad will occupy the space between two traverses which experience has shown should be about 15 feet apart.

1165. Preparation of the foreground. One of the first principles in improving the foreground is that an enemy attacking the trenches shall be continually exposed to fire especially in the last 400 or 500 yards. This requires a clearing of the foreground and a filling in of depressions or leveling of cover. Dead space may be swept by fire of trenches specially located for that purpose. Those features of the ground which obstruct the field of fire, restrict the view, or favor or the enemy's approach, should be removed as far as possible. On the other hand, features which favor the concealment of the trenches or increase the difficulty of the attack would better be left standing, especially when it is possible to fire through or over them.

1166. Revetments. By a revetment we mean a facing placed against the front or back wall of a trench to keep the earth in place.

When trenches are to be occupied for any length of time, they must be revetted. There are many forms of revetments. Sod revetments, stakes with brush behind them, stakes with planks, boards, or poles behind them and a common form seen in the trenches in Europe chicken wire with brush or canvas behind it.

[Pg 401]

1167. Drainage. All trenches should be dug so as to drain in case of rain. In favorable locations the trench may be constructed to drain automatically, by constructing it with an incline to one end. Under ordinary circumstances dry standing has to be provided in trenches by raising the foot level by the use of brush, boards, poles, etc. Bailing will have to be resorted to in most cases to drain the trench.

1168. Water Supply. At least $\frac{1}{2}$ a gallon of water per man per day should be supplied. The supply is almost invariably liable to be contaminated, therefore, it should be sterilized by boiling or by treating. These are usually located just off from the communicating trenches. Some form of receptacle should be used and all deposits covered with chemicals.

1169. Latrines. Numerous latrines must be constructed in the trenches' earth. These receptacles are removed from time to time and emptied in pits dug for that purpose. Urinal cans must also be provided and cared for in a similar manner.

1170. Illumination of the Foreground. Battlefield illumination is a necessity where night attacks may be expected, and also as a protection to the line of obstacles. Portable searchlights have become an accepted part of every army. In addition to these, trenches must be supplied with reflector lights, star bombs, rockets and flares, arranged so that they can be put into action instantaneously when the enemy approaches.

The foreground should be entirely illuminated, leaving the defenders in the shadow. If the light is too close to the defenders parapet, they are illuminated and become a good target. Some flares will burn for 20 minutes and may be thrown to the front as grenades, fired as rockets, shot from small mortars, or placed well to the front to be set off by trip wires close to the ground. The best light devised is one that can be fired well to the front from a small mortar and then hung suspended from an open parachute above the enemy. Bonfires can be laid ready for lighting when no other means is at hand. Whatever form of illumination is adopted, it should withstand bad weather conditions and prolonged bombardment.

1171. Telephones. When armies have been forced to trench warfare and time has permitted an elaborate system of trenches to be constructed, telephone communication is established as soon as possible. The central station, with the switch-board is located in a shelter in rear of the cover trenches and lines are run to all trenches, lookout stations and listening points.

1172. Siege works. Comprise devices used by besiegers and besieged in attack and defense of strong fortifications and especially those devices enable troops to advance under continuous cover.

CHAPTER XI

[Pg 402]

OBSTACLES

1173. Object. The main objects in placing obstacles in front of the trenches are, to protect them from surprise, and to stop the enemy's advance or to delay him while under the defender's fire.

1174. Necessity for obstacles. It is evident that the present tendency is to reduce the number of men assigned to constant occupancy of the first line trenches. This is due to the effectiveness of rifle fire at close range, the destructive effect of shell and shrapnel, the infrequency of daylight attack on intrenched positions, and the severe strain on the men. The aim seems to be the placing here and there of a lookout or trench guards, who, when necessity demands can call help from the near by splinterproofs, dugouts, etc., before the enemy can make his way through the obstacles. It has been found from experience in the European war that as long as shells are directed at the trenches no danger of attack is feared but, when the shells are concentrated against the obstacles the trenches are manned and preparations are made to resist an assault.

1175. Location. Obstacles must be so located that they will be exposed to the defenders' fire, and should be sheltered as far as possible from the enemy's artillery fire. They should be difficult to remove or destroy, should afford no cover for the enemy, and should not obstruct counter attacks. No obstacle should be more than 100 yards from the defender's trench. Care must be taken not to place them so close to the trench that hand grenades can be thrown into the trench from beyond the obstacle. Obstacles may be placed in one, two or three lines. As far as possible they should be concealed so that they will not betray the location of the trench.

1176. Kinds of Obstacles. The following are the most common kinds of obstacles:—

Abatis consisting of trees lying parallel to each other with the branches pointing in the general direction of approach and interlaced. All leaves and small twigs should be removed and the stiff ends of branches pointed.

Abatis on open ground is most conveniently made of branches about 15 feet long. The branches are staked or tied down and the butts anchored by covering them with earth. Barbed wire may be interlaced among the branches. Successive rows are placed, the branches of one extending over the trunks of the one in front, so as to make the abatis 5 feet high and as wide as desired. It is better to place the abatis in a natural depression or a ditch, for concealment and protection from fire. If exposed to artillery, an abatis must be protected either as above or else by raising a glacis in front of it. [Fig. 1](#) shows a typical form of abatis with a glacis in front. An abatis formed by felling trees toward the enemy, leaving the butt hanging to the stump, the branches prepared as before, is called a **slashing**, [Fig. 2](#). It gives cover, and should be well flanked.

[Pg 403]

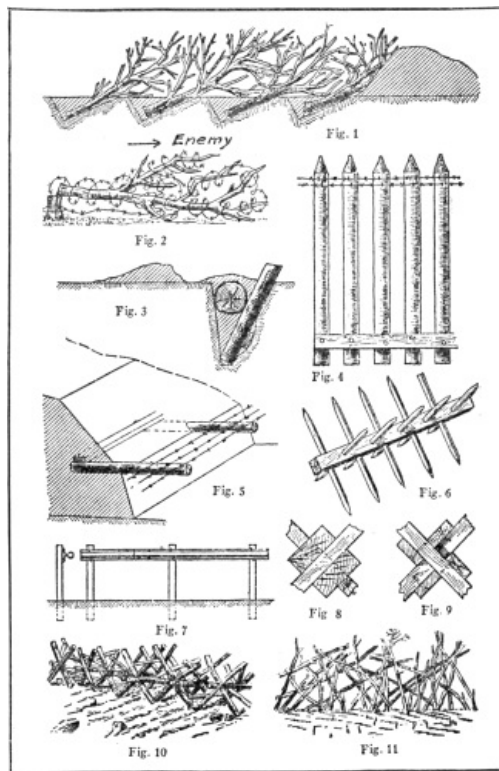

Plate I

1177. A palisade is a man-tight fence of posts. Round poles 4 to 6 inches in diameter at the large end are best. If the sticks run 5 to 8 inches, they may be split. If defended from the rear, palisades give some shelter from fire and the openings should be made as large as possible without letting men through. If defended from the flank, they may be closer, say 3 to 4 inches apart. The top should be pointed. A strand or two of barbed wire run along the top and stapled to each post is a valuable addition.

Palisading is best made up in panels of 6 or 8 feet length, connected by a waling piece, preferably of plank, otherwise of split stuff. If the tops are free, two wales should be used, both underground. If the tops are connected by wires, one will do.

Palisades should be planted to incline slightly to the front. As little earth should be disturbed in digging as possible, and one side of the trench should be kept in the desired plane of the palisade. If stones can be had to fit between the posts and the top of the trench, they will increase the stiffness of the structure and save time in ramming, or a small log may be laid in the trench along the outside of the posts. [Figs. 3](#) and [4](#) show the construction and placing of palisades.

1178. A fraise is a palisade horizontal, or nearly so, projecting from the scarp or counterscarp. A modern and better form consists of supports at 3 or 4 feet interval, connected by barbed wire, forming a horizontal wire fence. [Fig. 5](#).

1179. Cheveaux de frise are obstacles of the form shown in [Fig. 6](#). They are usually made in sections of manageable length chained together at the ends. They are most useful in closing roads or other narrow passages, as they can be quickly opened for friendly troops. The lances may be of iron instead of wood and rectangular instead of round; the axial beam may be solid or composite. [Figs. 8](#) and [9](#) show methods of constructing cheveaux de frise with dimension stuff.

1180. A formidable obstacle against cavalry consists of railroad ties planted at intervals of 10 feet with the tops $4\frac{1}{2}$ feet above the ground, and connected by a line of rails spiked securely to each, [Fig. 7](#). The rail ends should be connected by fish plates and bolted, with the ends of the bolts riveted down on the ends.

[Figs. 10](#) and [11](#) show forms of heavy obstacles employed in Manchuria by the Russians and Japanese, respectively. The former is composed of timber trestles, made in rear and carried out at night. The latter appears to have been planted in place.

1181. A wire entanglement is composed of stakes driven in the ground and connected by wire, barbed is the best, passing horizontally or diagonally, or both. The stakes are roughly in rectangular or quincunx order, but slight irregularities, both of position and height should be introduced.

[Pg 404]

In the **high entanglement** the stakes average 4 feet from the ground, and the wiring is horizontal and diagonal, [Fig. 12](#).

[Pg 405]

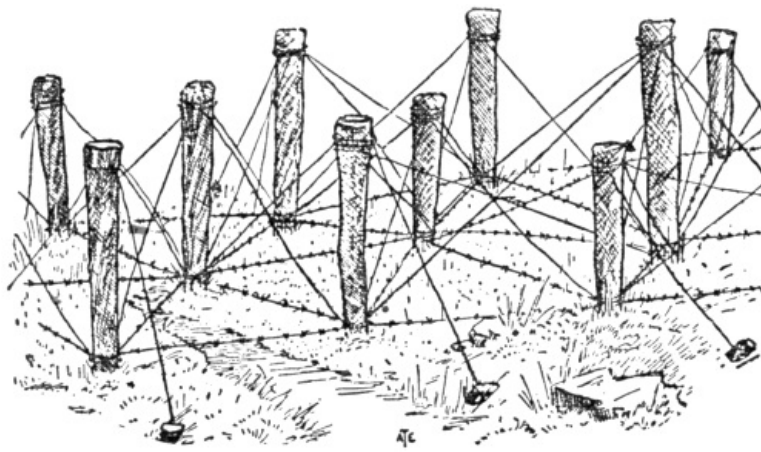

Stage II

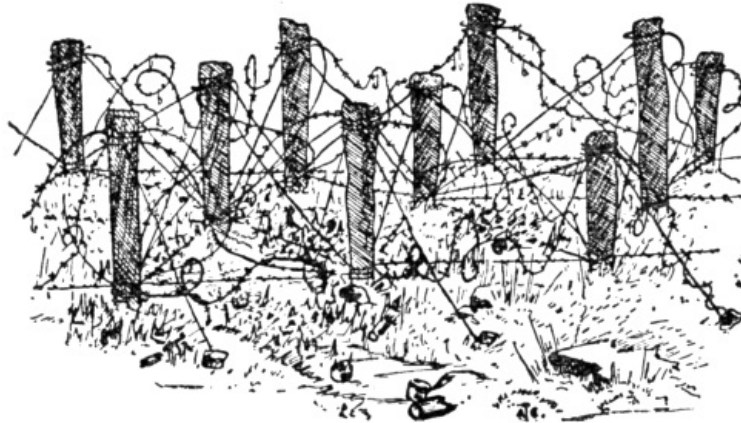

Fig. 12

High wire entanglement showing method of linking posts head to foot and foot to head. Wire, plain or barbed, then festooned with barbed wire. Bind wires where they cross. Use broken bottles, crows feet, planks with spikes or fishhooks in conjunction with this entanglement. (From Knowledge of War—Lake.)

The low wire entanglement has stakes averaging 18 inches above the ground and the wire is horizontal only. This form is especially effective if concealed in high grass. In both kinds the wires should be wound around the stakes and stapled and passed loosely from one stake to the next. When two or more wires cross they should be tied together. Barbed wire is more difficult to string but better when done. The most practicable form results from the use of barbed wire for the horizontal strands and smooth wire for the rest.

This is the most generally, useful of all obstacles because of the rapidity of construction, the difficulty of removal, the comparatively slight injury from artillery fire, and its independence of local material supplies.

1182. Time and materials. One man can make 10 sq. yds. of low and 3 sq. yds. of high entanglement per hour. The low form requires 10 feet of wire per sq. yd. and the high 30 feet. No. 14 is a suitable size. The smooth wire runs 58.9 ft. to the lb. A 100-lb. coil will make 600 sq. yds. of low or 200 sq. yds. of high entanglement. If barbed wire is used, the weight will be about 2½ times as much.

[Pg 406]

1183. Wire fence. An ordinary barbed-wire fence is a considerable obstacle if well swept by fire. It becomes more formidable if a ditch is dug on one or both sides to obstruct the passage of wheels after the fence has been cut. The fence is much more difficult to get through if provided with an apron on one or both sides, inclined at an angle of about 45°, as indicated in [Figs. 13](#) and [14](#). This form was much used in South Africa for connecting lines between blockhouses. When used in this way the lines of fence may be 300 to 600 yds. long, in plan like a worm fence, with the blockhouse at the reëntrant angles. Fixed rests for rifles, giving them the proper aim to enfilade the fence, were prepared at the blockhouses for use at night.

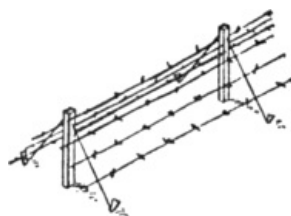

Fig. 13



Fig. 14

Such a fence may be arranged in many ways to give an automatic alarm either mechanically or electrically. The mechanical forms mostly depend on one or more single wires which are smooth, and are tightly stretched through staples on the posts which hold them loosely, permitting them to slip when cut and drop a counterweight at the blockhouse, which in falling explodes a cap or pulls the trigger of a rifle.

1184. Military pits or trous de loup are excavations in the shape of an inverted cone or pyramid, with a pointed stake in the bottom. They should not be so deep as to afford cover to the skirmisher. Two and one-half feet or less is a suitable depth. [Fig. 15](#) shows a plan and section of such pits.

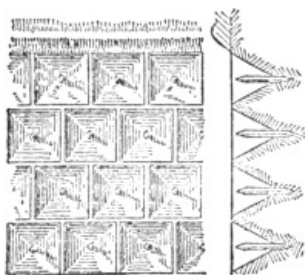

Fig. 15

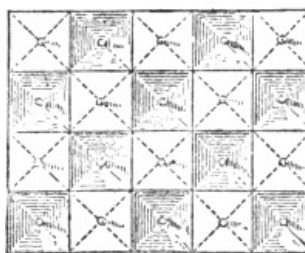

Fig. 16

They are usually dug in 3 or 5 rows and the earth thrown to the front to form a glacis. The rear row is dug first and then the next in front, and so on, so that no earth is cast over the finished pits.

An excellent arrangement is to dig the pits in a checkerboard plan, leaving alternate squares and placing a stake in each of them to form a wire entanglement, [Fig. 16](#). One man can make 5 pits on a 2-hour relief.

1185. Miscellaneous barricades. Anything rigid in form and movable may be used to give cover from view and fire and to obstruct the advance of an assailant. Boxes, bales and sacks of goods, furniture, books, etc., have been so used. The principles above stated for other obstacles should be followed, so far as the character of the materials will permit. The rest ingenuity must supply. Such devices are usually called barricades and are useful in blocking the streets of towns and cities.

[Pg 407]

1186. Inundations. Backing up the water of a stream so that it overflows a considerable area forms a good obstacle even though of fordable depth. If shallow, the difficulty of fording may be increased by irregular holes or ditches dug before the water comes up or by driving stakes or making entanglements. Fords have frequently been obstructed by ordinary harrows laid on the bottom with the teeth up.

The unusual natural conditions necessary to a successful inundation and the extent and character of the work required to construct the dams make this defense of exceptional use. It may be attempted with advantage when the drainage of a considerable flat area passes through a restricted opening, as a natural gorge, a culvert, or a bridge.

Open cribs filled with stones, or tighter ones with gravel or earth may form the basis of the obstruction to the flow of water. The usual method of tightening cracks or spaces between cribs is by throwing in earth or alternate layers of straw, hay, grass, earth, or sacks of clay. Unless the flow is enough to allow considerable leakage, the operation will not be practicable with field resources.

When the local conditions permit water to be run into the ditch of a parapet it should always be done.

1187. Obstacles in front of outguards should be low so they cannot be seen at night. A very simple and effective obstacle can be made by fastening a single strand of wire to the top of stout stakes about a foot high, and then placing another wire a little higher and parallel to, and about one yard in rear of, the first. The wires must be drawn tight, and securely fastened, and the stakes fairly close together, so that if the wire is cut between any two stakes the remainder will not be cut loose. Any one approaching the enemy will trip over the first wire, and before he can recover himself he will be brought down by the second. In the absence of wire, small sapplings may be used instead. Of course, they are not as good as wire, but it does not take much to trip up a man in the dark.

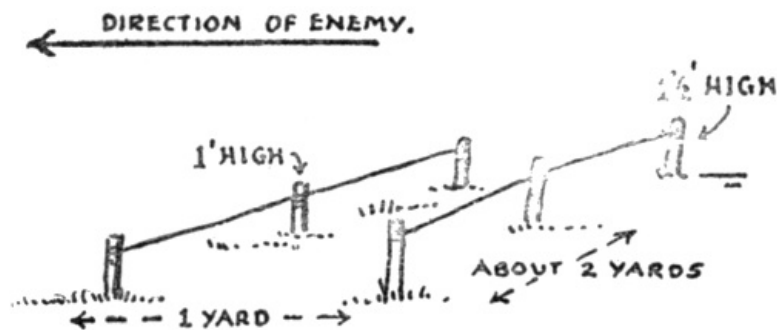

Fig. 17

Lessons from the European War

What follows is based on reports from the battle fronts in Europe.

1188. Wire entanglements. The war in Europe has proven that the wire entanglements are the most important and effective obstacle yet devised. Owing to the intensity of the opposing fire and in many cases to the short distance between the opposing trenches, it has become necessary to construct all forms of obstacles in portable sections which are carried or rolled quickly into place, either by soldiers rushing out in day light and quickly staking the obstacles down or by placing the obstacles quietly at night.

[Pg 408]

For placing wire entanglements at night, an iron post has been devised about $\frac{1}{4}$ of an inch in diameter, with eyelets for attaching the wire. The lower 18 inches is made as an auger, so that the posts can be quietly screwed into the ground at night and the wire attached. Another method of placing wire entanglements is to make them in sections and roll them up. These sections are usually about 20 feet long, the wire firmly fastened to the sharpened stakes. At a favorable moment the soldiers rush out, unrolling the sections as they go and with mauls quickly drive the stakes. Loose ends of wire enable the sections to be bound together as placed.

Another form of wire entanglement is shown in (Fig. 18). Triangular pyramids 3 feet 6 inches high are made of poles or timber. The pyramids are usually arranged in pairs with the wire on three faces so that, no matter if the obstacle is rolled over, a wire fence is presented. These obstacles are carried out and placed so as to break joints and are staked down as soon as possible.

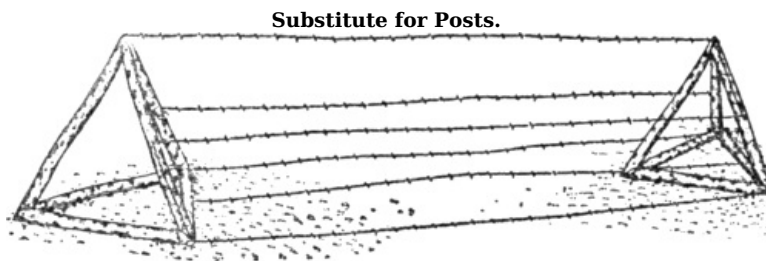

Fig. 18

The wire used for entanglements is found more convenient to handle when wound on a stake a yard in length, in a sort of figure eight winding. Special barbed wire of heavier material and barbs placed close together has been found much more effective than the commercial barbed wire.

In some localities electrified wire has been used. In such cases the obstacle is charged in sections, so that, if one section is grounded it will not affect the others.

1189. Wire cheveaux de frise. Two forms of this obstacle have appeared. Both are portable. They consist of two or more wooden crosses fastened at their centers to a long pole and connected with each other by barbed wire. This obstacle retains its effectiveness when rolled over. (Figs. 19 and 20) give an idea of their construction. The form shown in (Fig. 19) is often made small enough for individuals to carry. These are prepared in the trenches and used for throwing into one's own entanglements to make them more complex or may be carried when making an assault and thrown into the enemy's trenches to prevent movements from one part of the trench to another. The long stick projects out of the end to be used as a handle.

[Pg 409]

Wire Cheveaux de Frise



Fig. 19

Wire Cheveaux de Frise

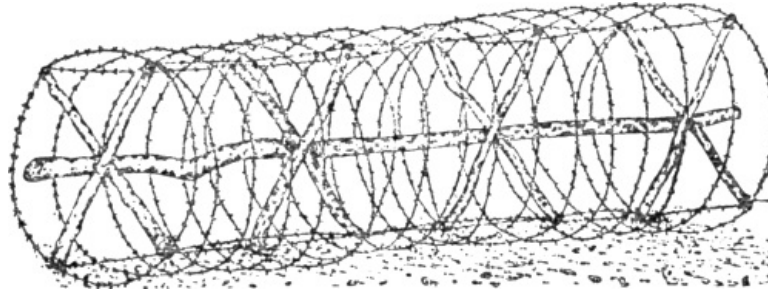

Fig. 20

1190. Guarding obstacles. It has been found necessary to keep a constant watch over obstacles after they have been placed.

1191. Listening posts. One of the best methods is to post one or more men in listening posts in or beyond the line of obstacles. These listening posts are rifle pits with over head cover, fully protected from fire from the rear as well as front, and loop holes for observation and fire. They are connected with the fire trenches by means of a covered communication or even tunnels in some cases and are provided with some form of prompt communication with the firing trenches by telephone, bell or other means. The communicating trench or tunnel is provided with a strong door which may be closed to prevent an enemy from securing access to the fire trench, in case the lookout is surprised. Pits with trap doors are also used to prevent an enemy from creeping up the tunnel to the fire trench.

These lookouts can give early warning of the approach of an enemy, either for the purpose of assault or cutting through the obstacles. In many instances they have detected mining operations of the enemy by hearing the blows of picks under ground.

1192. Automatic alarms. Many automatic alarms have been used to give warning of attack on the obstacles. These vary from the simple setting of a pistol or rifle, which is fired when the enemy attempts to cut through the entanglement, to intricate electrical alarms.

1193. Searchlights. Searchlights have been provided so that, the instant an alarm is given the obstacles are flooded by a brilliant light and the enemy exposed to fire.

CHAPTER XII

[Pg 410]

TRENCH AND MINE WARFARE^[14]

1194. Asphyxiating gases. The asphyxiating gases employed may be divided into three general classes, viz:

Suffocating gases, the most common of which are carbonic and nitrogen.

Poisonous gases, under which head come carbon monoxide and cyanogen.

Gases which affect the throat and bronchial tubes, such as chlorine and bromine. The latter class is most commonly employed.

The methods usually employed for liberating these gases are to have a plant some distance in rear of the trenches where the gas is stored under pressure and carried to the trenches through pipes, where it can be liberated towards the enemy's trenches when there is a favorable wind to carry it along; or, the gas may be carried in cylinders or other containers and liberated at the desired points. Hand grenades or bombs are also employed which, upon bursting, liberate the gas or in some cases scatter acids or caustic soda. Some of these bombs contain a chemical which when liberated affects the eyes, causing impaired vision. The Germans employ several kinds of shell containing gases of different densities, one of heavy gas fired as a curtain to the rear to permit reinforcement of the trenches and another of lighter gas to demolish the trenches

and destroy the firing line. As a general rule these gases are employed when the fire trenches of the opposing forces are close together though the shell containers may be used at long ranges. All of these gases being heavier than air lie close to the ground and flow over and down into the trenches.

1195. Protection against gases. The best protection against these gases, is a mask of some kind. The commonest form employed is a flexible mask that conforms to the head, is fitted with glass for seeing through, and has an arrangement of tubes and valves which require the wearer to inhale through his nose and exhale through his mouth.

These masks have an absorbent composed of hyposulphite of sodium or of 72 per cent of the nitrous thiosulphate and 28 per cent of bicarbonate of soda. This absorbent placed so that air must be breathed through it, neutralizes the acids in the gases. Soldiers are provided with these masks, sometimes with two of them, and are required to have them renewed every three months.

Trench sprays may be used to spray neutralizing liquid in the trenches to kill the gases.

The *favorable conditions* for the employment of gases are wind blowing toward the enemy's trenches and warm weather. *Unfavorable conditions* are rain, cold, and adverse winds.

In some localities weather vanes placed in the direction of the enemy's trenches and arranged so that they may be watched at night give an indication of favorable winds and enable the defender to prepare for a gas attack.

[Pg 411]

Before the masks were provided bonfires were prepared of oil soaked materials which; when ignited, produced an intense heat and the resulting column of air diverted the gas clouds.

1196. Liquid fire. By use of hand or motor driven pumps, and a light grade of petroleum, columns of liquid fire may be squirted into the opposing trenches. If the oil should fail to remain lighted it may be fired by bursting hand grenades or throwing fire balls into the trenches. This means of attack is employed when opposing trenches are close together.

As a defense measure ditches may be dug in front of the trenches and filled with a porous material which is then soaked with oil. Heavy oils, being hard to ignite, are not dangerous to the defense, and will remain with little loss for a long time. To make sure of prompt ignition gas lines are laid in the ditches. When turned on the gas readily ignites and the resulting fire produces great heat. Wire or barbed wire looped in the ditches and staked down makes this a formidable obstacle.

1197. Grenades and bombs are containers, designed to be thrown by hand, by a sling, fired as a rocket or from specially constructed mortars, or dropped from aerial craft. They burst by time or percussion fuses and may be improvised in a variety of forms and are most useful in close attack or defense. Their effect is local but they are very demoralizing to men's nerves.

1198. Hand grenades are designed to be thrown by the hand and vary greatly in construction. In general, however, they consist of a container filled with bullets or pieces of iron or other metal in the center of which is a charge of high explosive which scatters the bullets or fragments with deadly effect. The three methods of discharging a hand grenade are:

By time fuse which is lighted by hand. About 5 to 9 seconds is the time from ignition until the grenade bursts. This does not give the defender time to pick up the bomb and throw it out of the trench.

By friction primer and fuse. In this form of hand grenade a strap on the wrist with a short line attached with a hook on the end of it serves, when the hook is engaged in the ring of the grenade, to jerk the primer when the grenade is thrown. This automatically ignites the fuse which bursts the grenade in from 4 to 5 seconds.

By percussion. In this form of grenade the charge is fired when the grenade strikes the ground or object at which it is thrown. In this form of grenade a safety pin holds the plunger from the cap. When the grenade is to be thrown the safety pin is withdrawn.

As a general rule fuse burns at the rate of 1 inch in 1 and $\frac{1}{4}$ seconds; however each lot of fuse should be tested.

[Figs. 1](#) and [2](#) show two forms of improvised grenades. Common cans, such as preserved fruits and vegetables are shipped in commercially, make good containers. The usual weight of a hand grenade is about $1\frac{1}{2}$ pounds.

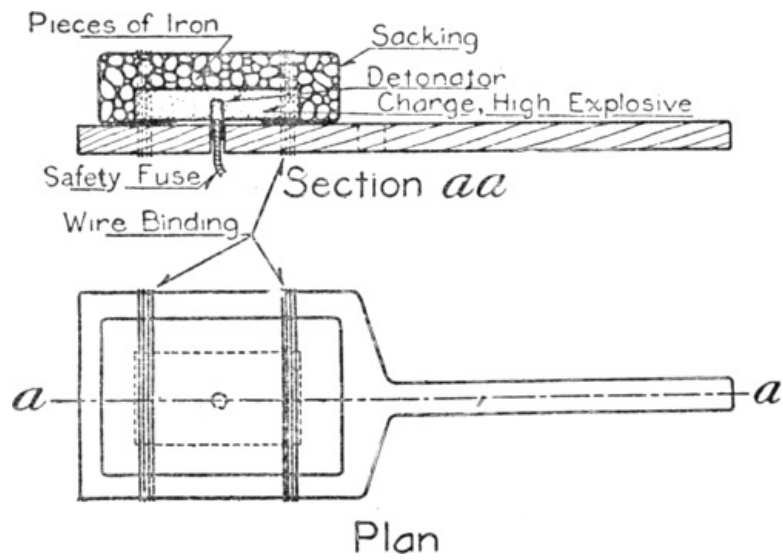

Fig. 1

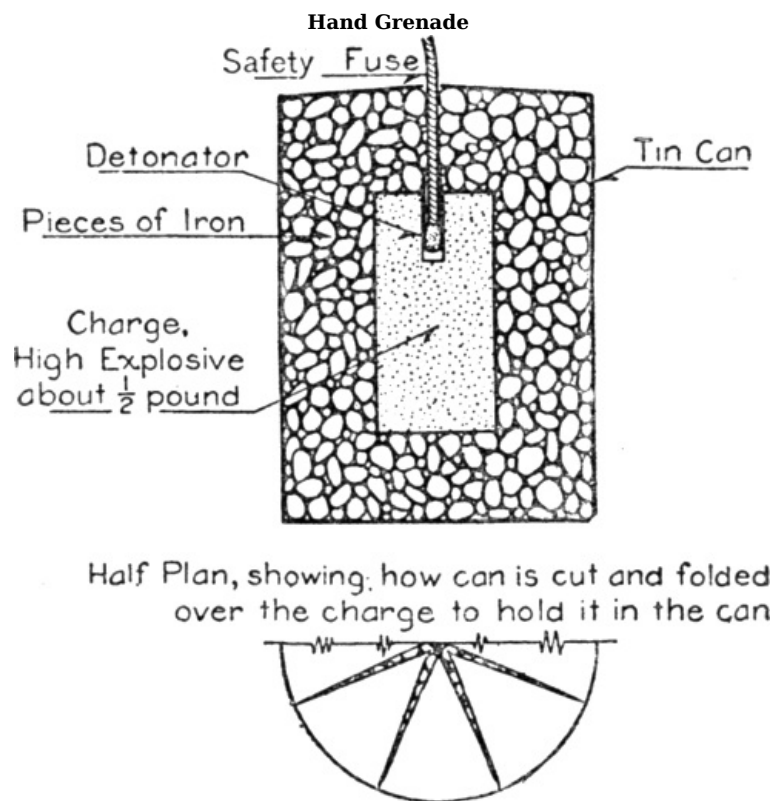

Fig. 2

1199. Other methods of throwing grenades. Many grenades have been designed to be fired from the ordinary rifle. This grenade has a rod which is inserted in the barrel of the rifle. A special charge of powder is used in the cartridge from which the bullet has been withdrawn.

[Pg 413]

Common slings, catapults, and other devises have been frequently used.

1200. Aerial mines. (Fig. 3.) This form of grenade is very heavy, often weighing 200 pounds and is fired from a trench mortar.



Fig. 3
Aerial Mine

1201. Winged torpedo. (Fig. 4.) This projectile is fitted with three winged vanes which steady its flight and greatly increase the accuracy. A rod fitted into its base enables it to be fired from a comparatively small trench, mortar. The torpedo weighs about 40 pounds and the mortar 200 pounds. The mortar, being light, can be carried from one part of the trench to another by two men.



Fig. 4
Winged Torpedo

The aerial mine and winged torpedo may be used effectively to beat down the enemy's defenses, destroying his sand bags and trenches, and cutting away wire entanglements and other obstacles. The winged torpedo having a greater range (500 yards) and being more accurate, is the more effective.

1202. Bombs from air-craft are some form of high explosive bomb which burst on striking. Another type of bomb used by aeroplanes consists of a container filled with steel darts. The bursting charge is fired by a fuse. The operator usually cuts the fuse so that the bomb will burst at a considerable altitude. The steel darts are scattered in all directions and have sufficient velocity to pass through a man or horse.

1203. Protection against hand grenades. (Fig. 5.) For protection against hand grenades and bombs a screen of wire netting may be erected in front of the trenches and arranged at such a slope that most of the grenades passing over the screen will clear the trench while those striking the netting will roll away from the trench. This protection is very satisfactory for communications, machine gun emplacements, etc., but, is of doubtful value in fire trenches as it does not permit an easy offensive by the defenders.



Fig. 5
Bomb Screen

1204. Tanks. The so-called "tanks," first used by the British armies in the battle of the Somme in September, 1916, are in reality armored caterpillar tractors carrying machine guns and capable of traversing rough ground, smashing down trees and entanglements, and passing across the ground between the opposing trenches over the shell holes made by the opposing artillery.

[Pg 415]

The machinery, guns and crew are contained in an armored body and the two tractor belts extend to full length on either side, being so arranged that the tank can climb a steep slope. From the meager data obtainable it would appear that the tanks carry from 4 to 6 machine guns in armored projections built out from the sides. These are provided with revolving shields permitting two guns to fire in any direction at one time.

The principle of the tractor is similar to that of those manufactured in the United States and used commercially in reclamation work. The addition of the armored body and guns makes the "military tank."

These "tanks" have proven of great value in village fighting, by smashing down barricades and driving machine guns from their positions in cellars and houses. They have also been used with some success in destroying obstacles.

The power of these new engines may be judged from their ability to smash down trees six inches in diameter and by means of cables to uproot trees as large as 15 inches in diameter.

These "tanks" are proof against rifle and machine gun fire, but are unable to withstand even light artillery.

1205. Helmets. Steel helmets made their appearance in the European war in 1915, as a protection to the soldier's head against rifle, machine gun and shrapnel fire. So successful were they that they are being furnished to all troops on the battlefield. Already several millions have been supplied. Where heretofore head wounds accounted for over 20 per cent of the casualties in trench warfare, the percentage has been reduced by the wearing of helmets to about one half per cent. While the helmet does not afford complete protection against rifle and shrapnel fire, it has been found that hits result only in severe concussion, where before fatal wound resulted. These helmets are painted khaki color.

[Pg 416]

1206. Masks. Steel masks for sentinels and snipers have been adopted by the Germans. This mask covers the head and face with curved surfaces which deflect bullets. Small eye holes permit a clear view of the target and a small section is omitted in the lower right side to permit bringing the rifle against the cheek in firing.

1207. Periscopes. Periscopes have been universally adopted in trench warfare for observing the enemy while keeping completely under cover. It is a simple arrangement of two mirrors in a vertical tube. The upper reflects the image of the object to the lower mirror which in turn reflects it to the eye of the observer. By raising the top of the periscope above the parapet the soldier can watch the foreground while at the same time remaining completely concealed himself.

A more elaborate periscope for the control of artillery fire has a collapsible tube which may be extended and elevated to a height of 75 feet.

1208. Sniperscope. This is a combination of the periscope and rifle by means of which a soldier can aim and fire his piece at an object without exposing himself above the parapet.

1209. Aids to firing. Rifles laid in notched boards placed in the parapet may be sighted and prepared for night firing, or a wire stretched just outside of the loophole on which the barrel of the rifle can rest when in the proper firing position to cover certain points, enables the soldier to fire effectively at night when it is too dark to aim.

1210. Mining. Military mining consists of digging communications and chambers underground and placing therein charges of explosives and firing such charges. Mining is slow and restricted in its application and therefore this method of attack is used against very strong points of the enemy's line,—a salient, a building, or other point,—held in great force. The aim in mine warfare is to make a sudden breach in the enemy's trench, destroy the flanking supports which could be used to stop this breach and then to take the trench by assault and organize it for defense before the enemy's forces, disorganized from the explosion, can recover.

Sometimes mines are placed in front of the trenches and exploded electrically when the enemy reaches them in attempting an assault.

1211. Countermining. The enemy, when mining operations are suspected, runs out tunnels to meet the opposing mine. Sometimes listening galleries are driven underground and men posted to detect the sound of mining operations. Once the direction of the opposing tunnel is discovered a charge of explosive is laid across its approach and fired at a moment when it will cause the most damage.

FOOTNOTES:

[14] To those desiring to go into the subject of trench warfare in detail, the author would recommend "Trench Warfare," by himself. George Banta Publishing Co., Menasha, Wis.; \$1.25.

CHAPTER XIII

[Pg 417]

MARCHES

(Based on Infantry Drill Regulations and Field Service Regulations)

1212. Marching principal occupation of troops in campaign. Marching constitutes the principal occupation of troops in campaign and is one of the causes of heaviest loss. This loss, however, may be materially reduced by proper training and by carrying out strictly the rules regulating the conduct of marches, especially the rules of march discipline.

1213. Physical training; hardening new troops. By systematic and progressive physical exercises and actual marching, Infantry can be accustomed to the fatigue of bearing arms and equipment.

With new or untrained troops, the process of hardening the men to this work must be gradual. It should begin with ten-minute periods of vigorous setting-up exercises three times a day to loosen and develop the muscles. One march should be made each day with full equipment, beginning with a distance of 2 or 3 miles and increasing the distance daily as the troops become hardened, until a full day's march under full equipment may be made without exhaustion.

1214. Long march not to be made with untrained troops. A long march should not be made with untrained troops. If a long distance must be covered in a few days, the first march should be short, the length being increased each succeeding day.

1215. A successful march. A successful march, whether in peace or war, is one that places the troops at their destination at the proper time and *in the best possible physical condition*. Therefore, every possible effort, by exercising care and judgment, and by enforcing march discipline, must be made by all officers and noncommissioned officers to have the troops reach their destination in good physical condition,—"ready for business."

Preparation

1216. The commander. The commander must give such instructions as will insure that the necessary preparations are made,—that the men and animals are in fit condition and that the men are properly equipped; that provision has been made for rations and ammunition; that the wagons are properly loaded; that the necessary arrangements have been made for caring for the sick, etc.

1217. Organization commanders. Every organization commander is responsible that such of

the above requirements as apply to his organization are complied with.

1218. Filling canteens. It is an invariable rule that all canteens must be filled before the march begins.

Starting

1219. Time to start. When practicable, marches begin in the morning, ample time being allowed for the men to breakfast, animals to feed, and the wagons or animals to be packed.

The time for reveille, if different from the usual hour, should be announced the evening before.

The exact hour for the start depends, of course, upon circumstances. However, as a rule, foot troops do not start before broad daylight; mounted troops, when practicable, about an hour after broad daylight.

In order to avoid intense heat, especially in the tropics, and also, in the case of long marches, to avoid reaching destination after dark, an earlier start than usual must be made.

Both men and animals rest well in the early morning hours, and should not, therefore, have this rest interrupted unless there is some real necessity for it.

Starting at night or at an hour that will cause a part of the march to be made at night, should, if possible, be avoided, because of the difficulties and disadvantages of night marching.

Conduct of the march

1220. The rate of march. The rate of march varies with the length of march, kind of troops, equipment carried, size of command, condition of troops, state of the weather, condition of roads, and other circumstances. However, whatever the rate may be it should be *uniform*, that is most important, as there is nothing that will irritate and tire a command more than a varying, un-uniform rate of march.

The rate of march is regulated by the commander of the leading company or some one designated by him, who should give the matter special attention, *the rate being checked from time to time by a watch.*

On a march of several days' duration the position of companies is ordinarily changed daily, so that each in turn leads.

With trained troops, in commands of a regiment or less, marching over average roads, the rate should be from $2\frac{3}{4}$ to 3 miles per hour. With larger commands carrying full equipment, the rate will be from 2 to $2\frac{1}{2}$ miles per hour.

Assuming that the length of step of the average man is 30 inches, the following rate-of-march table is deduced:

Steps per minute	Miles per hour
35 ($\frac{1}{5}$)	1
70	2
88 (in practice, 90)	$2\frac{1}{2}$
97 (in practice, 100)	$2\frac{3}{4}$
106 (in practice, 110)	3

[Note. By remembering that 35 ($\frac{1}{5}$) steps per minute gives 1 mile per hour, the number of steps per minute necessary to give a rate of 2, $2\frac{1}{2}$, $2\frac{3}{4}$ and 3 miles per hour, is quickly and easily obtained by multiplying 35 ($\frac{1}{5}$) by these numbers.]

In hot, sultry weather, with the men carrying the full pack, the rate of march would naturally be considerably less than on a cool day, with the command not carrying the pack. It is most important that these and other considerations affecting the rate of march be constantly borne in mind by the officer in command of the column, who should indicate to the commander of the leading company the number of steps to be taken per minute. In indicating the number of steps to be taken per minute, it should be considered whether the men at the head of the leading company are the average, above the average, or below the average in height. A short man, for example, would probably have to take 100 steps a minute to keep up with a tall man walking at the rate of 90 steps per minute.

1221. Marching capacity. The average marching capacity of Infantry is about 15 miles a day, but in extensive operations, involving large bodies of troops, the average is about 12 miles a day. Small commands of seasoned Infantry marching on good roads in cool weather can average about 20 miles a day.

1222. Halts. A halt of 15 minutes should be made after the first half or three quarters of an hour

of marching to enable the men to attend to the calls of nature and adjust their clothing. Judgment must be exercised in selecting the place for this halt; it should not be made in a village or other place where its object would be defeated.

After the first halt a halt of 10 minutes is made in each hour, that is, the troops march 50 minutes and then halt 10. Of course, the number and length of halts should be varied according to the weather, condition of the roads and the equipment carried by the men. In the tropics the best results are often obtained by marching 45 minutes and halting 15.

When the day's march will run well into the afternoon, a halt of about one hour should be made at noon and the men allowed to eat.

Places for long halts should be selected with care; woods, water and shade are desirable features. Arms are stacked and equipments removed.

Halts should not be made in or near towns or villages unless to procure water or supplies, and when so made, the men remain in column, details being sent for whatever is necessary.

In hot weather, especially in the tropics, it may be advisable in the case of long marches to halt for three or four hours during the hottest part of the day and finish the march in the late afternoon or early evening. As a general proposition, however, it is inadvisable to arrive at a strange place after nightfall or even late in the afternoon.

1223. Crossing bridges and fords. When a cause of delay,—for example, a damaged bridge,—is encountered, the troops in rear are notified of the minimum length of the delay; they then conduct themselves as at regular halts.

In ascending or descending slopes, crossing streams or other obstacles, or passing through defiles requiring a reduction of front, every precaution is taken to prevent interruption of the march of the troops in rear. If the distances are not sufficient to prevent check, units are allowed to overlap; if necessary, streams are crossed at two or more places at the same time; in passing through short defiles the pace is accelerated and the exit cleared at once.

[Pg 420]

If a company unit is delayed while crossing an obstacle, the head slackens the pace or halts until all of that unit has passed; it then resumes its place in the column, increasing the pace, if necessary.

Before attempting to cross with bodies of troops, careful examination is made of fords, boggy places, bridges of doubtful character, ice, etc., as the case may be.

Troops must never cross a bridge in cadence,—that is, the men must not be in step.

In fording a deep stream with a swift current, the men cross on as broad a front as possible, marching abreast and holding hands. They should not look at the water, but at the opposite shore. If the ford is wide enough, mounted troops may cross at the same time on the upstream side, thus breaking the force of the current.

Fords that are at all difficult delay long columns unless the troops cross at several places at once.

1224. Straggling and elongation of column. The marching efficiency of an organization is judged by the amount of straggling and elongation of the column and the condition of the men at the end of the march.

An officer of each company marches in its rear to prevent undue elongation and straggling. If there be only one officer with a company, the first sergeant performs this duty.

No man should leave the ranks without permission. If necessary for a man to fall out on account of sickness, he should be given a permit to do so by the company commander or the officer at the rear of the company. This permit is presented to the surgeon, who will admit him to the ambulance, have him wait for the trains, or follow and rejoin his company at the first halt.

It is the duty of all officers and noncommissioned officers to prevent straggling and elongation of the column.

MISCELLANEOUS

1225. Forced marches. A forced march may be said to be a march of more than average length.

Forced marches seriously impair the fighting power of even the best troops, and should be undertaken only in cases of necessity.

Such marches are generally made by increasing the number of marching hours. For large columns of Infantry marching long distances, increase of pace is seldom of value.

1226. Night marches. While night marches are some times made in very hot weather to avoid the heat of the day, they are generally made for the purpose of surprising the enemy, escaping observation by aeroplane, or for securing a favorable position from which to attack the enemy at

Moonlight and good roads are favorable for night marches.

Precaution must be taken that the proper road is followed and that contact between units is maintained, men being stationed, if necessary, to mark changes of direction. If necessary, guides are secured and charged with the duty of following the right road. When, due to unfavorable conditions, units cannot be kept well closed, men will be placed at forks and crossings of roads, especially on very dark nights.

When in hostile territory, silence is maintained; articles of equipment are secured to prevent rattling, and smoking and talking are not permitted. Also, under certain conditions villages and farmhouses are avoided on account of warning given by dogs.

Night marches impair the efficiency of a command and are never undertaken without good reason.

1227. Compliments. As a rule, troops on the march pay no compliments; individuals salute when they address, or are addressed by, a superior officer.

1228. Protection on the march. Protection on the march is furnished by covering detachments known as advance guards, rear guards and flank guards.

1229. Fitting of shoes and care of feet. In view of the fact that the greater part of the Infantry soldier's occupation in the field consists of marching, too much stress cannot be laid upon the importance of his paying special attention to the fitting of his shoes and the care of his feet.

An Infantryman with sore feet is like a lame duck trying to keep up with the rest of the flock.

Keep your feet clean. Dirty feet invite blisters. An excellent preventative against sore feet is to wash them every night in hot (preferably salt) water and then dry them thoroughly. If this is not practicable, then mop them every evening with a wet towel and invigorate the skin with a good rubbing.

Keep the nails cut close.

Rubbing the feet with hard soap, grease, or oil of any kind, and putting ordinary talcum powder in the shoes before starting on a march, are very good to prevent sore feet.

Blisters should be pricked and the water let out, but the skin must never be removed. Adhesive plaster on top of the blister will prevent the skin from being pulled off.

In case of sore or blistered feet, considerable relief can be obtained by rubbing them with tallow from a lighted candle and a little whiskey or alcohol in some other form, and putting the socks on at once.

A little alum in warm water is excellent for tender feet.

The old soldier has learned from long experience in marching, to turn his socks inside out before putting them on thus putting the smooth side next to his skin and possible seams or lumps next to the shoe. The thickness of the sock protects the skin and helps prevent blisters.

Under no circumstances should a soldier ever start on a march with a pair of new shoes.

Each soldier should have on hand at all times two pair of serviceable shoes well broken in.

Remember that it is much better to prevent sore feet by taking the precautions outlined above, than it is to have to treat your feet after they have become sore.

CHAPTER XIV

CAMPS

1230. Principles governing selection of camp sites. The following basic principles govern in the selection of camp sites:

- (a) The water supply should be sufficient, pure, and accessible.
- (b) The ground should accommodate the command with as little crowding as possible, be easily drained, and have no stagnant water within 300 yards.
- (c) There should be good roads to the camp and good interior communication.
- (d) Camp sites should be so selected that troops of one unit need not pass through the camp grounds of another to reach their own camp.

(e) Wood, grass, forage, and supplies must be at hand or obtainable.

(f) In campaign, tactical considerations come first in the selection of camp sites, capability of defense being especially considered, and, as a result, troops may have to camp many nights on objectionable ground.

(g) However, sanitary considerations must always be given all the weight possible consistent with the tactical requirements. Through no fault of their own, troops occupying an unsanitary site may suffer greater losses than in the battles of a long campaign.

1231. Desirable camp sites. The following conditions are desirable for camp sites:

(a) Porous soil, covered with stout turf and underlaid by a sandy or gravelly subsoil.

(b) High banks of rivers, provided no marshes are near.

(c) In cold weather, a southern exposure, with woods to the north to break the cold winds.

(d) In warm weather, an exposure toward the prevailing winds, with site moderately shaded by trees.

1232. Undesirable camp sites. The following conditions are undesirable for camp sites:

(a) Clay soil, or where the ground water approaches the surface, such sites being damp and unhealthful.

(b) Alluvial, marshy ground, and ground near the base of hills, or near thick woods or dense vegetation are also damp.

(c) Ravines and depressions are likely to be unduly warm and to have insufficient or undesirable currents.

(d) Proximity to marshes or stagnant water is usually damp, and has mosquitoes, which transmit malaria, dengue fever and yellow fever.

(e) Old camp sites are dangerous, as they are often permeated by elements of disease which persist for considerable periods.

(f) Dry beds of streams are subject to sudden freshets.

(g) In the tropics troops should not camp nearer than 500 yards to native huts or villages because of danger from malarial infection.

[Pg 424]

1233. Form and dimensions of camps. The form and dimensions of camps depend upon the tactical situation and the amount and nature of ground available. However, in general, the form and dimensions of a regimental or battalion camp should conform as nearly as practicable to the diagram on the opposite page, and camps of all sizes should, as far as possible, conform to the principles, regarding arrangement, underlying the diagram given on the opposite page, which gives the general form, dimensions, and interior arrangements of a camp for a regiment of Infantry at war strength. In certain cases, particularly in one-night halts in the presence of the enemy, camps must of necessity be contracted, while in other cases, where a more extended halt is contemplated and where tactical reasons will permit, better camp sanitation may be secured, and a more comfortable arrangement made by the expansion of camp areas.

1234. Making camp. The command should be preceded by the commanding officer or a staff officer, who selects the camp site, and designates, by planting stakes, the lines of tents, the positions of the sinks, guard tent, kitchens, picket line, etc.

After the companies are marched to their proper positions and arms are stacked, the details for guard and to bring wood, water, dig sinks, pitch tents, handle rations, etc., should be made before ranks are broken.

Immediately upon reaching camp and before the men are allowed to go around, patrolling sentinels should be established to prevent men from polluting the camp site or adjoining ground before the sinks are constructed.

Sentinels should be posted over the water supply without delay.

As soon as the tents have been pitched and the sinks dug, the camp should be inspected and all unnecessary sentinels relieved.

The tents should be pitched and the sinks dug simultaneously.

Should the troops reach camp before the wagons, the companies may be divided into squads and set to work clearing the ground, gathering fire wood, collecting leaves, grass, etc., for beds, etc.

The moment a command reaches camp its officers and men usually want to go here and there under all sorts of pretexts. No one should be allowed to leave camp until all necessary

instructions have been given.

Enlisted men should not be permitted to leave camp without permission of their company commanders.

Sick call should be held as soon as practicable after the tents have been pitched.

CAMP OF A REGIMENT OF INFANTRY, WAR STRENGTH

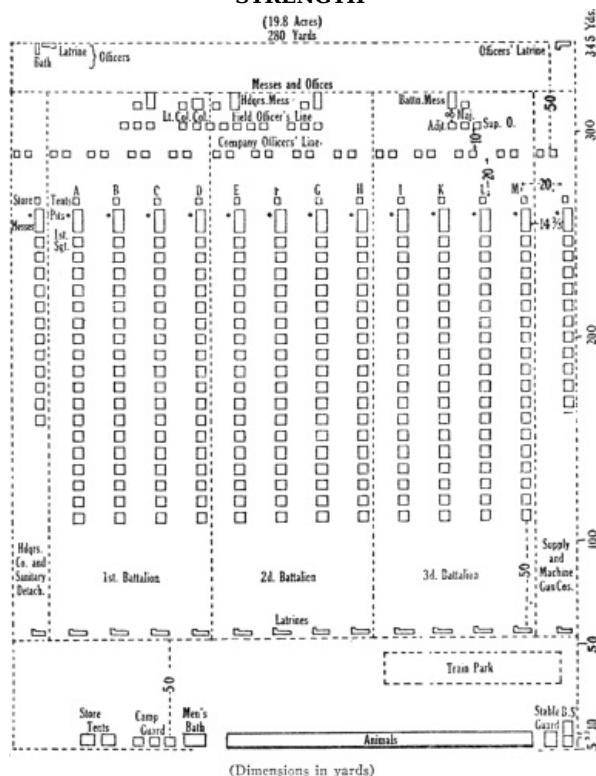

Fig. 1

MISCELLANEOUS

1235. Retreat. In camp retreat formation should always be under arms, an officer being present with each company and inspecting the arms.

1236. Parade ground. In front of every camp of permanent nature, there should be a parade ground for drills and ceremonies.

1237. Camping on fordable stream. In camping for the night on a fordable stream that is to be crossed, cross before going into camp, unless there is some tactical reason for not doing so; for a sudden rise, or the appearance of the enemy, might prevent the crossing the next morning.

1238. Windstorms. Whenever windstorms are expected, the tent pegs should be secured and additional guy ropes attached to the tents.

Tents may be prevented from blowing down by being made fast at the corners to posts firmly driven into the ground, or by passing ropes over the ridge poles and fastening them to pegs firmly set into the ground.

1239. Making tent poles and pegs fast in loose soil. If the soil be loose or sandy, stones or other hard material should be placed under the tent poles to prevent their working into the soil, thus leaving the tent slack and unsteady. When the soil is so loose that the pegs will not hold at all, fasten the guy ropes to brush, wood or rocks buried in the ground.

1240. Trees sometimes dangerous. While trees add very much to the comfort of a camp, care should be exercised not to pitch tents near trees whose branches or trunks might fall.

CHAPTER XV

CAMP SANITATION

1241. Definition. By "Camp Sanitation" is meant the adoption of measures to keep the camp in a healthy condition. These measures comprise:

(a) The disposal, so as to render them harmless and prevent pollution, of all wastes, refuse and

excreta from men and animals in suitable places provided therefor;

(b) The care exercised in handling, preparing and serving food;

(c) The adequacy of shelter for the men;

(d) The maintenance of proper drainage;

(e) The supply of water for bathing and washing, and the maintenance of a pure supply for drinking.

1242. Camp expedients. "Camp-expedients" is the name given the mechanical means used to put into effect some of the measures, named above, connected with camp sanitation, and usually consist of latrines, kitchen sinks, urinal tubs, rock or earth incinerators, and drainage ditches.

1243. Latrines. The latrines must be dug immediately upon reaching camp—their construction must not be delayed until the camps have been pitched and other duties performed. The exact location of the latrines should be determined by the commanding officer, or by some officer designated by him, the following considerations being observed:

1. They should be so located as not to contaminate the water supply.
2. They should not be placed where they can be flooded by rain water from higher ground, nor should they be so placed that they can pollute the camp by overflow in case of heavy rains.
3. They should be as far from the tents as is compatible with convenience—if too near, they will be a source of annoyance; if too far, some men, especially at night, and particularly if affected with diarrhoea, will defecate before reaching the latrine. Under ordinary circumstances, a distance of about 50 yards is considered sufficient.

Latrines for the men are always located on the opposite side of the camp from the kitchens, generally one for each company unit and one for the officers of a battalion or squadron. They are so placed that the drainage or overflow can not pollute the water supply or camp grounds.

When the camp is for one night only, straddle trenches suffice. In camp of longer duration, and when it is not possible to provide latrine boxes, as for permanent camps, deeper trenches should be dug. These may be used as straddle trenches or a seat improvised. When open trenches are used the excrement must be kept covered at all times with a layer of earth. In more permanent camps the trenches should be 2 feet wide, 6 feet deep, and 15 feet long, and suitably screened. Seats with lids are provided and covered to the ground to keep flies from reaching the deposits; urinal troughs discharging into trenches are provided. Each day the latrine boxes are thoroughly cleaned, outside by scrubbing and inside by applying, when necessary, a coat of oil or whitewash. The pit is burned out daily with approximately 1 gallon oil and 15 pounds straw. When filled to within 2 feet of the surface, such latrines are discarded, filled with earth, and their position marked. All latrines and kitchen pits are filled in before the march is resumed. In permanent camps and cantonments, urine tubs may be placed in the company streets at night and emptied after reveille.

[Pg 428]

All latrines must be filled before marching. The following illustration shows a very simple and excellent latrine seat which can be made and kept in the company permanently for use in camps on the march:

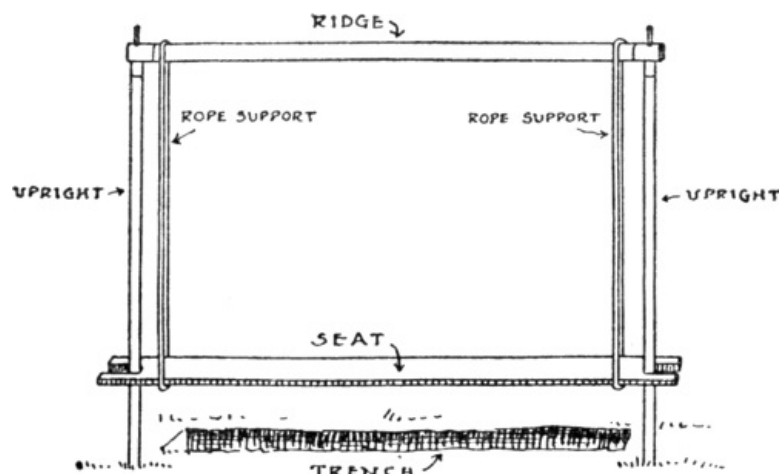

Fig. 1

Urinal troughs, made of muslin and coated with oil or paint, should discharge into the trenches.

1244. Urinal tubs. When obtainable, urinal tubs or cans should be placed in the company streets at night, their location being indicated by lighted lanterns, the tubs or cans being removed at reveille.

1245. Kitchens. Camp kettles can be hung on a support consisting of



Fig. 2

a green pole lying in the crotches of two upright posts of the same character. A narrow trench for the fire, about 1 foot deep, dug under the pole, not only protects the fire from the wind but saves fuel.

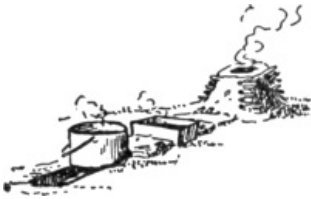

Fig. 3

A still greater economy of fuel can be effected by digging a similar trench in the direction of the wind and slightly narrower than the diameter of the kettles. The kettles are then placed on the trench and the space between the kettles filled in with stones, clay, etc., leaving the flue running beneath the kettles. The draft can be improved by building a chimney of stones, clay, etc., at the leeward end of the flue.

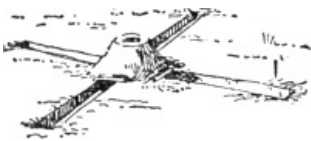

Fig. 4

Four such trenches radiating from a common central chimney will give one flue for use whatever may be the direction of the wind.

[Pg 429]

A slight slope of the flue, from the chimney down, provides for drainage and improves the draft.

The lack of portable ovens can be met by ovens constructed of stone and covered with earth to better retain the heat. If no stone is available, an empty barrel, with one head out, is laid on its side, covered with wet clay to a depth of 6 or more inches and then with a layer of dry earth equally thick. A flue is constructed with the clay above the closed end of the barrel, which is then burned out with a hot fire. This leaves a baked clay covering for the oven.

A recess can be similarly constructed with boards or even brushwood, supported on a horizontal pole resting on upright posts, covered and burnt out as in the case of the barrel.

When clay banks are available, an oven may be excavated therein and used at once.

To bake in such ovens, first heat them and then close flues and ends.

Food must be protected from flies, dust, and sun. Facilities must be provided for cleaning and scalding the mess equipment of the men. Kitchens and the ground around them must be kept scrupulously clean.

Solid refuse should be promptly burned, either in the kitchen fire or in an improvised crematory.

In temporary camps, if the soil is porous, liquid refuse from the kitchens may be strained through gunny sacking into seepage pits dug near the kitchen. Flies must not have access to these pits. Boards or poles, covered with brush or grass and a layer of earth may be used for this purpose. The strainers should also be protected from flies. Pits of this kind, dug in clayey soil, will not operate successfully. All pits should be filled with earth before marching.

As a precautionary measure against setting the camp on fire, all dry grass, underbrush, etc., in the immediate vicinity of the kitchen should be cut down.

In case of a fire in camp, underbrush, spades, shovels, blankets, etc., are used to beat it out.

Gunny sacks dipped in water are the best fire fighters.

Burning away dried grass and underbrush around exterior of camp is a great protection against fire from outside.

1246. Kitchen pits. Pits of convenient size should be constructed for the liquid refuse from the kitchens. Solid refuse should be burned either in the kitchen fire or at some designated place, depending upon whether the camp is of a temporary or permanent nature. Unless the camp be of a very temporary nature, the pits should be covered with boards or other material in order to exclude the flies.

All pits should be filled in with earth before breaking camp.

1247. Incinerators. The incineration pit shown in the following diagram, affords an excellent, simple and economical way of disposing of camp waste and offal, tin cans and dish-water included:

[Pg 430]

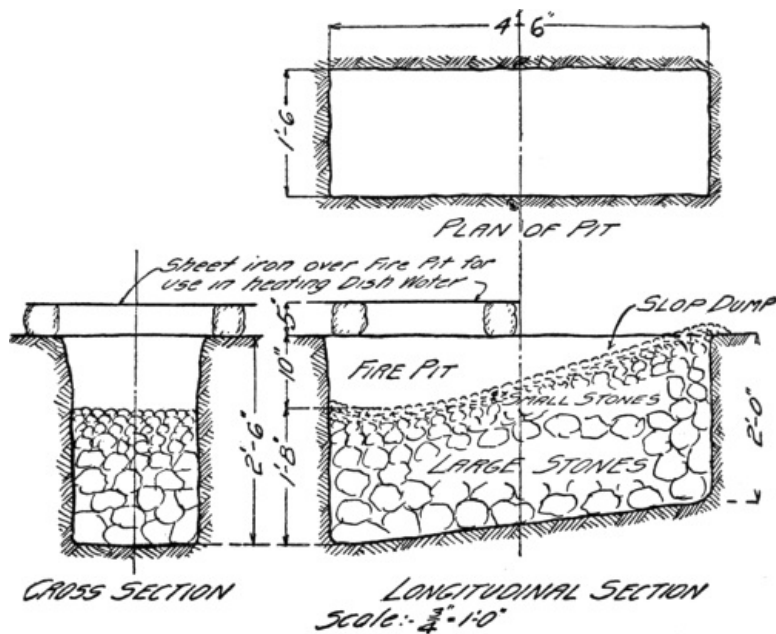

Fig. 5

Description:

The pit is about 4½ feet long, 1½ feet wide and 2 feet deep at one end and 2½ feet at the other. It is partially filled with stones, the larger ones on the bottom and the smaller on the top. At one end of the pit the stones extend a little above the surface, and slope gradually toward the other end until the fire pit is reached ten inches below the surface of the trench. Over the fire pit, about five inches above the ground, is placed a crab or a piece of boiler iron, on which is boiled all the water for washing dishes, etc. The fire pit is only about one-half of the stone surface, as the radiated heat keeps the rest of the stones hot, causing all dish and slop water to evaporate quickly.

Any tin cans that may be thrown into the fire pit are removed after a short exposure to the heat and placed in a trench especially dug for the purpose.

The company incinerator shown below was used with great success by some of our troops at Texas City, Texas. The rocks should not be too large. The men should be instructed to drop all liquid on the sides of the incinerator and throw all solid matter on the fire—the liquids will thus be evaporated and the solids burned. Until the men learn how to use the incinerator properly, a noncommissioned officer should be detailed to supervise its use.

[Pg 431]

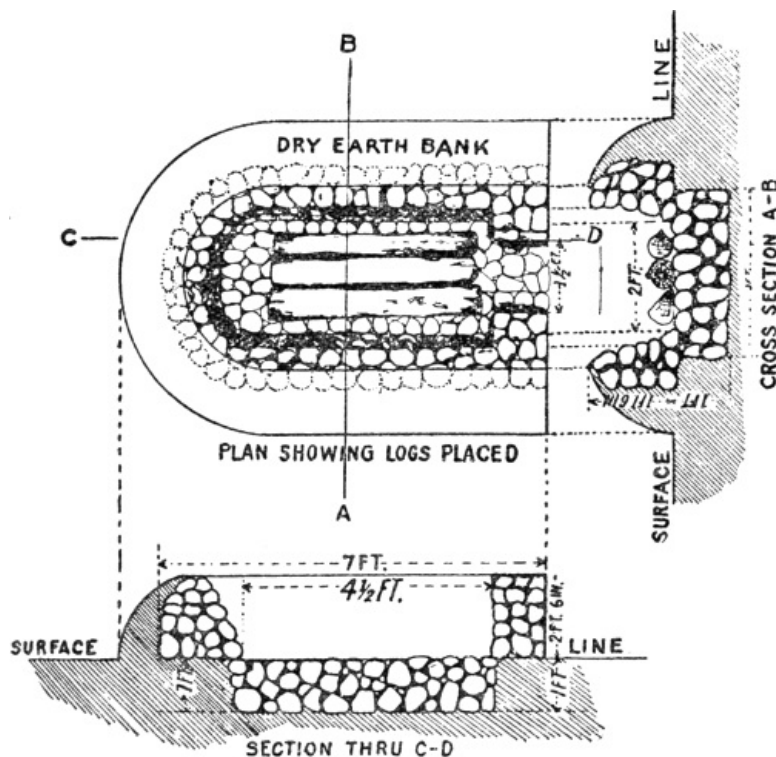

Fig. 6

1248. Drainage. When camp is established for an indefinite period, drainage should be attended to at once. Each tent should have a shallow trench dug around it and the company and other streets ditched on both sides, all the trenches and ditches connecting with a ditch that carries the water from the camp. All surface drainage from higher ground should be intercepted and turned

aside.

1249. Avoiding old camp sites. The occupation of old camp sites is dangerous, since these are often permeated by elements of disease which persist for considerable periods.

1250. Changing camp sites. Camp sites must be changed promptly when there is evidence of soil pollution or when epidemic disease threatens. Also, a change of camp site is often desirable in order to secure a change of surroundings and to abandon areas that have become dusty and cut up.

[Pg 432]

1251. Bunks. Place a number of small poles about seven feet long close together, the upper ends resting on a cross pole about six inches in diameter and the lower ends resting on the ground; or, the poles may be raised entirely off the ground by being placed on cross poles supported by forked stakes at the corners; on the poles place grass, leaves, etc.

1252. Wood. The firewood should be collected, cut and piled near the kitchen. Dry wood is usually found under logs or roots of trees.

If wagons are not heavily loaded it is sometimes a good plan to bring a few sticks of dry wood from the preceding camp, or to pick up good wood en route.

1253. Water. Precautionary measures should always be taken to prevent the contamination of the water, and a guard from the first troops reaching camp should at once be placed over the water supply.

If the water is obtained from a stream, places should be designated as follows for getting water:

- (1) For drinking and cooking;
- (2) For watering animals;
- (3) For bathing and for washing clothing.

The first designated place should be farthest up the stream; the others, in the order named, downstream.

Where two bodies of troops are to camp on the same stream one must not pollute the water to be used by the other. This can be arranged by the commanders agreeing upon a point where both commands will obtain their drinking water, upon a second point where animals will be watered, etc.

If the stream be small, the water supply may be increased by building a dam.

Small springs may be dug out and each lined with a gabion, or a barrel or box with both ends removed, or with stones, the space between the lining and the earth being filled with puddled clay. A rim of clay should be built to keep out surface drainage. The same method may be used near swamps, streams, or lakes to increase or clarify the water supply.

Water that is not known to be pure should be boiled 20 minutes; it should then be cooled and aerated by being poured repeatedly from one clean container to another, or it may be purified by apparatus supplied for the purpose.

Arrangements should be made for men to draw water from the authorized receptacles by means of a spigot or other similar arrangement. The dipping of water from the receptacles, or the use of a common drinking cup, should be prohibited.

In the field it is sometimes necessary to sterilize or filter water. The easiest and surest way of sterilizing water is by boiling. Boiled water should be aerated by being poured from one receptacle to another or by being filtered through charcoal or clean gravel. Unless boiled water be thus aerated it is very unpalatable and it is with difficulty that troops can be made to drink it.

Filtration merely clarifies—it does not purify. The following are simple methods of filtration:

[Pg 433]

1. Dig a hole near the source of supply so that the water may percolate through the soil before being used.
2. Sink a barrel or box into the ground, the water entering therein through a wooden trough packed with clean sand, gravel or charcoal.
3. Place a box or barrel in another box or barrel of larger size, filling the space between with clean sand, gravel, moss or charcoal, and piercing holes near the bottom of the outer barrel and near the top of the inner. The filter thus constructed is partly submerged in the water to be filtered.
4. Bore a small hole in the bottom of a barrel or other suitable receptacle, which is partly filled with layers of sand, gravel, and, if available, charcoal and moss. The water is poured in at the top and is collected as it emerges from the aperture below.

The amount of water used by troops is usually computed at the rate of five gallons for each man and ten gallons for each animal per day.

1254. Rules of sanitation. The following rules of sanitation are to be observed:

Men should not lie on damp ground. In temporary camps and in bivouac they raise their beds if suitable material, such as straw, leaves, or boughs can be obtained, or use their ponchos or slickers. In cold weather and when fuel is plentiful the ground may be warmed by fires, the men making their beds after raking away the ashes.

When troops are to remain in camp for some time all underbrush is cleared away and the camp made as comfortable as possible. Watering troughs, shelter in cold weather, and shade in hot, are provided for the animals, if practicable.

The camp is policed daily after breakfast and all refuse matter burned.

Tent walls are raised and the bedding and clothing aired daily, weather permitting.

Tents must be kept clean and in order.

The company street and the ground around the tents must be kept clean.

Food, slop water, rags, paper, empty tin cans, and other trash and refuse must not be thrown on the ground, but should be put in the box, can or other receptacle provided for the purpose or thrown into the incinerator.

The food must be protected from flies, dust and sun.

Under no circumstances must the company street or any other part of the camp grounds be defiled by urinating or defecating thereon. The urinal tub and the latrine must invariably be used.

When an open trench is used as a sink, each individual must always cover his excrement with dirt.

If the sink is inclosed by a box with stool-covers, the covers must always be put down as soon as one is through using them so as to keep out the flies. However it is found in practice that men will not do this therefore it is a good plan to construct the covers so that they will close automatically when a man rises from the seat.

[Pg 434]

Kitchen garbage must be burned in a pit or incinerator, or put into *covered* cans and hauled away. *The covers must be kept on the cans at all times*, so as to keep out the flies.

Horses are not to be ridden through camp except on the roadways.

As soon as a tent is pitched it should be ditched.

When it rains the guy ropes must be loosened to prevent the tent pegs from pulling out and the tent falling down.

The body and the clothes should be cleaned daily as thoroughly as the means at hand will permit.

In the morning wash the face and neck and don't fail to use your tooth brush afterward.

In the continued absence of opportunity for bathing it is well to take an air bath and a moist or dry rub before getting into fresh underclothes.

If the lack of opportunity to wash clothes continues for any length of time, soiled clothes and bedding must be frequently exposed to the sun and air. Sunshine is a good germ killer.

If there are mosquitoes in camp, mosquito bars must be used by men when asleep, and headnets by men on guard and other duty. Also, if in a malarial country, about five grains of quinine should be taken daily, preferably just before supper. In localities where a pernicious form of malaria prevails, daily doses of ten grains of quinine should be given.

In the tropics troops are require to camp at least 500 yards away from all native huts or villages as a preventative measure against malaria. Men are also prohibited from visiting these places at night for the same reason.

Clean your mess kit thoroughly after every meal, if practicable, washing same with soap and boiling water.

The company cooks must keep everything in the kitchen and mess tent clean with hot water and soap. Boil the utensils and dish rags, and be sure to throw all slops and garbage into the kitchen incinerator.

Rest and sleep are most important to preserve the health, so, keep the body rested by plenty of sleep. Do not join idle parties going to walk the streets of the nearest town at nights, nor sit up late playing cards.

Observe in camp even with greater care than when in barracks the rules of health and personal hygiene. (See [pars. 1451-1477.](#))

1255. Your camp, your home. A soldier should always look upon his camp as his home, which it is for the time being. Your tent is your bedroom; the company street, your sitting-room; the latrine, your toilet; the mess tent, your dining-room; the camp kitchen, your kitchen; the bathing facilities, your bathroom. And as you are careful about keeping your bedroom and the other rooms of your home in a clean and orderly condition, so should you do your share to keep your tent and the other parts of camp in a clean, sanitary condition.

CHAPTER XVI

[Pg 435]

INDIVIDUAL COOKING

1256. Importance of individual cooking. It often happens in campaign that it is impossible to have the field ranges and cooking utensils accompany the troops, and in such case each man must cook his own food in his mess kit. Also, it frequently happens that detachments operating away from their companies must do individual cooking.

All food we eat should be properly cooked, if not, stomach or intestinal trouble will result. Hence, the importance of every soldier learning how to cook in his mess kit the main components of the ration.

1257. Fire. Remember that the best fire for cooking is a small, clear one, or better yet, a few brisk coals. Dig a hole in the ground with your bayonet and make your fire in it with dry wood, starting it with paper, shavings, dry leaves or dry grass.

If preferred the fire may be made between two small flat stones or bricks, care being taken to so place the stones that the draft will pass between them. The mess pan can be placed on the stones, across the fire, and the cup for boiling the coffee at the end away from the draft where it will get the most heat.

This method will, as a rule, be necessary on rocky or stony ground.

1258. Recipes. The following recipes, which are based on the War Department publication, "Manual for Army Cooks," require the use of only the soldier's mess kit,—knife, fork, spoon, cup, and mess pan:

Meats

1259. Bacon. Cut side of bacon in half lengthwise. Then cut slices about five to the inch, three of which should generally be sufficient for one man for one meal. Place in a mess pan with about one-half inch of cold water. Let come to a boil and then pour the water off. Fry over a brisk fire, turning the bacon once and quickly browning it. Remove the bacon to lid of mess pan, leaving the grease for frying potatoes, onions, rice flapjacks, etc., according to recipe.

1260. Fresh meat. To fry.—To fry, a small amount of grease (1 to 2 spoonfuls) is necessary. Put grease in mess pan and let come to a smoking temperature, then drop in the steak and, if about one-half inch thick, let fry for about one minute before turning—depending upon whether it is desired it shall be rare, medium, or well done. Then turn and fry briskly as before. Salt and pepper to taste.

Applies to beef, veal, pork, mutton, venison, etc.

1261. Fresh meat. To broil.—Cut in slices about 1 inch thick, from half as large as the hand to four times that size. Sharpen a stick or branch of convenient length, say from 2 to 4 feet long, and weave the point of the stick through the steak several times so that it may be readily turned over a few brisk coals or on the windward side of a small fire. Allow to brown nicely, turning frequently. Salt and pepper to taste. Meat with considerable fat is preferred, though any meat may be broiled in this manner.

[Pg 436]

1262. Fresh meat. To stew.—Cut into chunks from one-half inch to 1 inch cubes. Fill cup about one-third full of meat and cover with about 1 inch of water. Let boil or simmer about one hour or until tender. Add such fibrous vegetables as carrots, turnips, or cabbage, cut into small chunks, soon after the meat is put on to boil, and potatoes, onions, or other tender vegetables when the meat is about half done. Amount of vegetables to be added, about the same as meat, depending upon supply and taste. Salt and pepper to taste. Applies to all fresh meats and fowls. The proportion of meat and vegetables used varies with their abundance and fixed quantities can not be adhered to. Fresh fish can be handled as above, except that it is cooked much quicker, and potatoes, onions, and canned corn are the only vegetables generally used with it, thus making a chowder. A slice of bacon would greatly improve the flavor. May be conveniently cooked in mess pan or tin cup.

Fresh Vegetables

1263. Potatoes, fried. Take two medium-sized potatoes or one large one (about one-half pound), peel and cut into slices about one-fourth inch thick and scatter well in the mess pan in which the grease remains after frying the bacon. Add sufficient water to half cover the potatoes, cover with the lid to keep the moisture in, and let come to a boil from fifteen to twenty minutes. Remove the cover and dry as desired. Salt and pepper to taste. During the cooking the bacon already prepared may be kept on the cover, which is most conveniently placed bottom side up over the cooking vegetables.

1264. Onions, fried. Same as potatoes.

1265. Potatoes, boiled. Peel two medium-sized potatoes or one large one (about one-half pound), and cut in coarse chunks of about the same size—say 1½-inch cubes. Place in mess pan and three-fourths fill with water. Cover with lid and let boil or simmer for fifteen or twenty minutes. They are done when easily penetrated with a sharp stick. Pour off the water and let dry out for one or two minutes over hot ashes or light coals.

1266. Potatoes, baked. Take two medium-sized potatoes or one large one cut in half (about one-half pound.) Lay in a bed of light coals, cover with same and smother with ashes. Do not disturb for thirty or forty minutes, when they should be done.

1267. Rice. Take two-thirds of a cup of water and bring to a boil. Add 4 spoonfuls of rice and boil until soft, that is, until it can be mashed by the fingers with but little resistance. This will require about 15 minutes. Add 2 pinches of salt and, after stirring, pour off the water and empty the rice out on the lid of the mess pan.

1268. Canned Tomatoes. One 2-pound can is generally sufficient for five men.

[Pg 437]

Stew. Pour into the mess pan one man's allowance of tomatoes, add about two large hardtacks broken into small pieces, and let come to a boil. Add salt and pepper to taste, or add a pinch of salt and one-fourth spoonful of sugar.

Or, having fried bacon, pour the tomatoes into the mess pan, the grease remaining, and add, if desired, two broken hardtacks. Set over a brisk fire and let come to a boil.

Or, heat the tomatoes just as they come from the can, adding two pinches of salt and one-half spoonful of sugar if desired.

Or, especially in hot weather, eaten cold with hard bread they are very palatable.

Hot Breads

1269. Flapjack. Take 6 spoonfuls of flour and one-third spoonful of baking powder and mix thoroughly (or dry mix in a large pan before issue, at the rate of 25 pounds of flour and three half-pound cans of baking powder for 100 men). Add sufficient cold water to make a batter that will drip freely from the spoon, adding a pinch of salt. Pour into the mess pan, which should contain the grease from fried bacon, or a spoonful of butter or fat, and place over medium hot coals sufficient to bake so that in from five to seven minutes the flapjack may be turned over by a quick toss of the pan. Fry from five to seven minutes longer or until, by examination, it is found to be done.

1270. Hoecake. Hoecake is made exactly the same as a flapjack by substituting *corn meal* for *flour*.

Drinks

1271. Coffee. Fill cup about two-thirds full of water and when it boils add, 1 heaping spoonful of coffee, and let boil 5 minutes. Stir grains well when adding. Add 1 spoonful of sugar, if desired. Let simmer ten minutes after boiling. Settle with a dash of cold water or let stand for a few minutes.

1272. Tea. Fill cup about two-thirds full of water and when it boils add ½ spoonful of tea, and let boil 5 minutes. Add 1 spoonful of sugar, if desired. Let stand or "draw" 8 minutes. If allowed to stand longer, the tea will get bitter, unless separated from the grounds.

1273. Cocoa. Fill cup about two-thirds full of water and when it boils add 1 heaping spoonful of cocoa and let boil 5 minutes. Stir when adding until dissolved. Add 1½ spoonful of sugar, if desired. Let cool. (If available, milk should be used instead of water, and should be kept somewhat below the boiling point. A 1-pound can of evaporated milk with 3½ quarts of water will make 1 gallon of milk of the proper consistency for making cocoa or chocolate.)

1274. Chocolate. Same as cocoa, using 1 cubic inch of chocolate.

Emergency Ration

1275. Emergency Rations. Detailed instructions as to the manner of preparing the emergency ration are found on the label with each can. Remember that even a very limited amount of bacon or hard bread, or both, taken with the emergency ration makes it far more palatable, and greatly extends the period during which it can be consumed with relish. For this reason it would be better to husband the supply of hard bread and bacon to use with the emergency ration when it becomes evident that the latter must be consumed, rather than to retain the emergency ration to the last extremity to be used exclusively for a longer period than two or three days.

[Pg 438]

CHAPTER XVII

[Pg 439]

CARE AND PRESERVATION OF CLOTHING AND EQUIPMENT

1276. General. A soldier's clothing and equipment are issued to him by his government for certain purposes, and he has, therefore, no right to be in any way careless or neglectful of them.

The importance that the Government attaches to the proper care and preservation of the soldier's clothing and equipment, is shown by the fact that the matter is made the subject of one of the Articles of War, the 84th, which prescribes that any soldier who, through neglect, loses or spoils his arms, clothing or accouterments shall suffer such punishment as a court-martial may direct.

Clothing

1277. Every article of clothing in your hands should receive as much care and attention as you give your person.

Not only will your clothes last longer if properly cared for, but you will look neater and better dressed, which will add much to your military appearance.

Every soldier should have an A-1 whisk broom and no article of clothing should ever be worn without first being thoroughly brushed.

1278. Pressing. Occasional pressing helps to preserve and freshen clothes,—it puts new life into the cloth.

Blue clothing and woolen olive drab when worn regularly should be pressed about once a week.

In a company where there is an iron for general use there is no reason why every soldier should not press his own clothes.

1279. Chevrons and stripes can be cleaned by moistening a clean woolen rag with gasoline and rubbing the parts and then pressing with a hot iron.

1280. Leggings. When soiled, leggings must be washed. If the leggings are allowed to dry without being rung out, they will look better.

1281. Service hat and the caps require nothing but brushing.

Shirts, underwear, socks, etc., should be carefully folded and put away neatly.

1282. A special suit of clothing for inspections, parades, etc. Set aside your best suit of clothes for inspections, parades and other ceremonies. The uniform worn at these formations should not be worn around in the barracks,—every man has sufficient "second best" garments for barrack use.

1283. Putting away. Uniforms should be dried thoroughly, brushed and properly folded before being put away. The number of folds should be reduced to a minimum.

Before uniforms are put away they should be carefully examined and any missing buttons, tears or stains should be attended to at once.

[Pg 440]

Lockers and other places in which clothing is kept must be free from dust. They should be wiped off occasionally with a cloth wrung out of soap suds.

1284. Stains. Tailors usually remove stains with a rubber made by rolling tightly a piece of woolen cloth of some kind, about 2 inches wide, until the roll is about an inch in diameter.

Rings in removing stains may be avoided by rubbing until very nearly dry.

1285. Grease spots. Ordinarily benzine is a good stain remover in case of grease spots, but its use is more or less dangerous. It should be used in an open room or out of doors and never near a fire or lights.

"Carbena," which can be purchased in almost any drug store, is excellent for removing stains and it is perfectly safe.

Carbon tetrachloride (Merck's) is much cheaper than "Carbona" and about equally as good. It retails at 45c a pint at nearly all drug stores.

Grease spots can also be removed by placing a piece of brown paper, newspaper, blotting paper or other absorbent paper over the stain, and pressing with a hot iron.

1286. Rust or ink stains can be removed with a solution of oxalic acid. Apply rapidly and rinse at once with plenty of fresh water; this is most important—otherwise it will probably discolor the material.

1287. Sweat stains can not be removed. However, the color can be partially restored and the material cleaned with a solution of ammonia and water— $\frac{1}{3}$ liquid ammonia, $\frac{2}{3}$ water.

1288. The shine that is sometimes left from pressing is caused by leaving the iron on too long or using an iron that is too hot.

This shine, if the cloth is not scorched, can be removed by "sponging," i. e., by placing a piece of damp muslin cloth on the material and then applying the iron only long enough to steam the surface of the garment.

1289. Grease and oil stains on white trouser stripes can be removed with benzine, naphtha or gasoline, applied with a stiff nail brush. Stains of rust and ink can be removed by means of oxalic acid (2 ounces of oxalic acid to 1 pint of water—dissolves quickest in warm water) applied with cloth or brush, then rinsed thoroughly with plain water and sponge. After the stripes have dried, apply English pipe-clay, rubbing with the cake itself; then rub in uniformly with woolen cloth rubber—rub vigorously—then brush off surplus pipe-clay.

1290. Paint spots. Turpentine will take out paint spots.

1291. Gilt ornaments and gilt buttons should be polished as often as necessary in order to keep them fresh and bright. Use a button stick in cleaning buttons, so as not to soil the cloth.

Shoes

[Pg 441]

(Instructions issued by the Quartermaster General's Office, June 16, 1899.)

1292. General care. Shoes should at all times be kept polished. By being so kept they are made more pliable and wear longer.

Shoes must withstand harder service than any other article worn, and more shoes are ruined through neglect than by wear in actual service.

Proper care should be taken in selecting shoes to secure a proper fit, and by giving shoes occasional attention much discomfort and complaint will be avoided.

1293. Selection. A shoe should always have ample length, as the foot will always work forward fully a half a size in the shoe when walking, and sufficient allowance for this should be made. More feet are crippled and distorted by shoes that are too short than for any other reason. A shoe should fit snug yet be comfortable over ball and instep, and when first worn should not lace close together over the instep. Leather always stretches and loosens at instep and can be taken up by lacing. The foot should always be held firmly, but not too tightly in proper position. If shoes are too loose, they allow the foot to slip around, causing the foot to chafe; corns, bunions, and enlarged joints are the result.

1294. Repairs. At the first sign of break, shoes should be repaired, if possible. Always keep the heels in good condition. If the heel is allowed to run down at the side, it is bad for the shoe and worse for the foot; it also weakens the ankle and subjects the shoe to an uneven strain, which makes it more liable to give out. Shoes, if kept in repair, will give double the service and comfort.

1295. Shoe dressing. The leather must not be permitted to become hard and stiff. If it is impossible to procure a good shoe dressing^[15], neat's-foot oil or tallow are the best substitutes; either will soften the leather and preserve its pliability. Leather requires oil to preserve its pliability, and if not supplied will become brittle, crack, and break easily under strain. Inferior dressings are always harmful, and no dressing should be used which contains acid or varnish. Acid burns the leather as it would the skin, and polish containing varnish forms a false skin which soon peels off, spoiling the appearance of the shoe and causing the leather to crack. Paste polish containing turpentine should also be avoided.

1296. Perspiration. Shoe becoming damp from perspiration should be dried naturally by evaporation. It is dangerous to dry leather by artificial heat. Perspiration contains acid which is harmful to leather, and shoes should be dried out as frequently as possible.

1297. Wet shoes. Wet or damp shoes should be dried with great care. When leather is subjected to heat, a chemical change takes place, although no change in appearance may be noted at the time. Leather when burnt becomes dry and parched and will soon crack through like pasteboard when strained. This applies to leather both in soles and uppers. When dried the leather should

[Pg 442]

always be treated with dressing to restore its pliability. Many shoes are burned while on the feet without the knowledge of the wearer by being placed while wet on the rail of a stove or near a steam pipe. Care should be taken while shoes are being worn never to place the foot where there is danger of their being burned.

(Note. To dry wet shoes, the last thing at night take a few handfuls of dry clean pebbles, heat them in meat can, kettle or campfire until very hot; place them in the shoes,—they will dry them out thoroughly in a few hours,—shake once in awhile. Oats or corn may also be used, but they are not available always and pebbles usually are. Now is an excellent time to grease or oil the shoes.—Author.)

1298. Keep shoes clean. An occasional application of soap and water will remove the accumulation of old dressings and allow fresh dressing to accomplish its purpose.

1299. Directions for polishing. Russet leather should be treated with great care. Neither acid, lemon juice, nor banana peel should be used for cleaning purposes. Only the best liquid dressing should be used and shoes should not be rubbed while wet.

1300. Liquid dressing. Care should be taken in using liquid dressing. Apply only a light coat and *allow this to dry into the leather before rubbing* with a cloth. Too much dressing is wasteful.

EQUIPMENT

(Instructions issued by the Ordnance Department in Pamphlet No. 1965, July 12, 1915.)

Cloth Equipment

1301. General. All cloth equipment should be brushed frequently with a stiff bristle brush. A dry scrub brush may be used.

It should be washed only under the direction and supervision of an officer.

During ordinary garrison duty it should rarely be necessary to wash the equipment.

When the equipment becomes soiled a light local washing will frequently be sufficient, but when dirty it should unhesitatingly be given a good thorough washing,—otherwise it may be expected that it will become unsanitary and rot.

During field service it is to be expected that the equipment will become soiled much more rapidly. Always on return to garrison from field service and as opportunity offers in the field, equipment should be thoroughly washed.

1302. Instructions for washing cloth equipment.

(a) *Preparation of soap solution.* Dissolve in nine cups of hot water one cake of H. & H. soap or a substitute which is issued by the Ordnance Department.

One cup of this solution is sufficient to clean the entire cloth and web equipment of one man. One cake per squad is a liberal allowance.

The H. & H. soap issued by the Ordnance Department is made especially for washing cloth fabrics liable to fade. If for any reason this soap is not obtainable, a good laundry soap (Ivory or equal) may be used, but in no case should the yellow soap issued by the Quartermaster Corps be used.

[Pg 443]

(b) *Brushing.* Brush the equipment thoroughly to remove all dust and mud before washing.

(c) *Washing.* Spread the belt, haversack, etc., on a clean board or rock and apply the soap solution with a scrub brush. When a good lather appears, wash off with clear water.

In the case of a bad grease spot the direct application of soap to the brush will ordinarily be sufficient to remove it.

(d) *Drying.* Always dry washed equipment in the shade. The sun will bleach the fabric.

On return from a march in the rain, dry the equipment in the shade, if practicable.

1303. Shelter tent. The shelter tent is cleaned and cared for as prescribed above for the cloth equipment.

When practicable always dry your shelter tent before folding and packing it. (Author.)

Mess Outfit

1304. Knife. The knife blade is made of tempered steel, and when put away for a long period

should be covered with a light coating of oil to prevent rust.

Keep your knife clean by washing in soap and water after every meal.

Do not use the blade as a pry.

If the point is broken, grind the blade down to a new point.

1305. Fork. Keep your fork clean by washing with hot water and soap after every meal.

Never use the prongs of your fork for prying open tops of cans, extracting corks, etc.

Don't permit your knife, fork or spoon to remain in vinegar or other foodstuffs for a long period, as verdigris will form. This corrodes the metal and is poisonous.

1306. Spoon. Keep your spoon clean by washing with soap and water after every meal.

1307. Meat can. Do not carry meat of any kind or other greasy substance in the meat can for a long period, as it will corrode the aluminum.

If the rivets securing the hinge to the meat can become loose, a few blows with a hammer or hand ax on the outside ends of the rivets, the heads of the rivets being backed up on a piece of metal, will tighten them.

If the hinge pin becomes loose, a nail can be used to replace it, the nail being cut with a service wire cutter and the ends of the nail headed over slightly with a few blows of a hammer.

1308 Bacon can. The interior of the bacon can should always be kept clean and free from hardened grease or dirt by frequent washings with soap and water.

If the cover becomes loose on the body of the can, the upper half of the body may be bent out until the cover is again tight. [Pg 444]

If the cover is too tight, a slight amount of flattening with a hammer on the edge of the cover, resting on a wooden block, will usually extend the cover sufficiently.

1309. Condiment can. When not in use, always remove the contents. Many cans have been ruined by neglecting to do this.

See that the threaded ends do not become rusty.

The can should be disassembled at all inspections, so that the inspecting officer may see that no rust is present.

1310. Cup. The cup is made of aluminum and excessive heat damages aluminum.

In using the cup for cooking never allow the contents to evaporate entirely. In other words, never hold an empty cup over a fire.

Keep your cup clean with hot water and soap,—preferably H & H soap.

1311. Canteen. Although as a rule, only soap and water should be used in cleaning aluminum, a little sand can be used to advantage in cleaning the canteen.

Particular attention must be taken to see that canteens are properly cleaned after they have been filled with coffee, milk or any other fluid containing organic matter.

Being made of aluminum the canteen is easily dented, and care must be taken to prevent this.

When not actually in use the canteen should habitually be emptied and the cup left off to dry.

Intrenching Tools

1312. Pick mattock. If the blade of the mattock is deformed, it should be straightened in a vise.

In the field, cracked handles of pick mattocks, shovels, and hand axes should be wrapped with cord.

1313. Shovel. Do not use the side edges of the shovel blade as a mattock, for this will deform the blade.

If the blade becomes bent, straighten it with a hammer on a block of wood.

Keep your intrenching tool free from rust, being especially careful that no rust gets into the sockets.

Leather Equipment

1314. General. Because of the value of leather equipment and its rapid deterioration if neglected, the proper care of leather is most important.

1315. Materials. Two agents are necessary to the proper cleaning of leather,—a *cleaning agent* and an *oiling agent*.

The *cleaning agent* issued by the Ordnance Department is castile soap; the *oiling agents* are neat's-foot oil and harness soap.^[16]

The soap cleans the surface of the leather, and removes from the surface pores of the leather, dirt, sweat, and other foreign matter, so that the oil can more readily penetrate the pores and saturate the fibers, thus making the leather pliable and elastic. [Pg 445]

1316. Cleaning. Daily, or as often as used, leather equipment should be wiped off with a cloth slightly dampened in water, merely to remove mud, dust or other foreign substances.

This daily care will do much to maintain the appearance of the equipment, but it is, however, insufficient of itself to properly preserve it.

Leather should never be cleaned by immersing in water or holding under a hydrant.

At intervals of from one to four weeks, depending upon the circumstances, it is essential that the equipment be thoroughly cleaned in accordance with the following instructions:

(a) Separate all parts, unbuckle straps, remove all buckles, loops, etc., where possible.

(b) Wipe off all surface dust and mud with a damp (not wet) sponge. After rinsing out the sponge, a lather is made by moistening the sponge in clear water, squeezing it out until nearly dry, and rubbing it vigorously upon castile soap. When a thick, creamy lather is obtained, thoroughly clean each piece of the equipment without neglecting any portion. Each strap should be drawn its entire length through the lathered sponge so as to actually remove the salt, sweat, and dirt from each leather piece.

(c) After again rinsing the sponge make a thick lather as described above with the saddle soap. Go over each separate piece, thoroughly working the lather well into every part of the equipment, remembering that its action is that of a dressing.

(d) After the leather has been allowed to become partially dry, it should be rubbed vigorously with a soft cloth to give it the neat, healthy appearance that is desired.

1317. Oiling. If the foregoing instructions have been carefully followed, the appearance should now be perfect, and if the leather is soft and pliable nothing further is required. It will be found, however, that it will be necessary from time to time to apply a little oil. It is not practicable, owing to different conditions of climate and service, to prescribe definitely the frequency of oiling. It has been found that during the first few months of use a set of new equipment should be given at least two applications of oil per month. Thereafter it is entirely a matter of judgment, as indicated by the appearance and pliability of the leather. Frequent, light applications are of more value than infrequent heavy applications.

1318. New equipment. Before using, perfectly new equipment should in all cases be given a light application of neat's-foot oil; soap is unnecessary because the leather is clean. The application of oil is important because leather equipment frequently remains a considerable time in an arsenal or depot and in spite of periodical inspections and dubbing it is probably too dry for severe service.

1319. How to apply oil. The quantity of oil to be used can not be definitely prescribed. If not enough oil is used, the leather will be stiff and brittle; if too much is used, it will soil the clothing and accumulate dirt. The leather should, therefore, be saturated with sufficient oil to be soft and pliable without excess sufficient to cause it to exude. [Pg 446]

In applying the oil the following general instructions should govern:

(a) The oil should be applied to the flesh side of the equipment where practicable when the leather is clean and still damp after washing (about half dry), because it penetrates more uniformly when applied from the flesh side, and when the leather is damp. If the leather is dry it will absorb the oil like blotting paper, preventing proper distribution.

(b) The oil should be applied with an oiled rag or cotton waste by long, light, quick strokes—light strokes, so that the pressure applied may not squeeze out an excess of oil; quick strokes, so that the leather may not absorb an undue amount of oil. The endeavor should be to obtain a light, even distribution.

(c) After applying the oil the leather equipment should be allowed to stand for 24 hours, if practicable, in a warm dry place. It should then be rubbed with a dry cloth to remove any unabsorbed oil.

Points to Be Remembered

1320. Therefore, from what has been said, the following points must be remembered:

- (a) Keep leather clean.
- (b) Keep leather pliable by frequent applications of oil.
- (c) Use only materials furnished by the Ordnance Department. *Shoe polishes*, etc., are almost invariably injurious.
- (d) *Dry all leather wet from whatever cause, in the shade*; never in the sun or close to a steam radiator, furnace, or boiler.
- (e) Leather should habitually be stored in a cool, dry place, *without artificial heat*.

FOOTNOTES:

- [15] "Viscol" is the best oil for softening all kinds of leather that the author knows of. It is made by The Viscol Co, East Cambridge, Mass., and can be obtained from the post exchange.
- [16] Proport's Harness Soap is excellent. However, since the European War its issue has been discontinued by the Ordnance Department. "Viscol," obtainable from the post exchange, is the best oil for softening all kinds of leather that the author knows of.

CHAPTER XVIII

[Pg 447]

CARE AND DESCRIPTION OF THE RIFLE

Care

1321. Importance. The care of his rifle should be the soldier's first thought; for, if he would have it take care of him in time of danger, he must take care of it at all times.

It is a generally recognized fact that more rifles become inaccurate and unserviceable by the lack of care than by firing.

The instructions for taking care of the rifle are few and simple. Learn them well and *apply them constantly*—it only requires a little care and patience. You will be well repaid for it. It may some day save your life.

1322. Care of bore requires work. The bore of the rifle is manufactured with the greatest care in order that a high degree of accuracy may be obtained, and it should, therefore, be properly cared for.

The proper care of the bore requires conscientious, careful work, but it pays well in reduced labor of cleaning and in prolonged accuracy life of the rifle, and better results in target practice.

1323. How to clean the bore. With the cleaning rod the bore must always be cleaned from the breech—never from the muzzle. Cleaning from the muzzle is liable to wear and otherwise injure the mouth of the barrel, which is easily injured and thus the piece rendered inaccurate.

First, remove the bolt from the rifle, place the muzzle on the floor, a board, or piece of canvas, and do not remove it therefrom while the cleaning rod is in the bore. Never place the muzzle on the bare ground, lest dirt should get into it. (Note. Of course, if a rack is provided for cleaning rifles, it should be used instead of placing the muzzle on the floor.)

To clean the bore use patches of rag, preferably cotton flannel, cutting them into squares of such size that they may easily run through the barrel.

1324. What care of the bore consists of. Briefly stated, the care of the bore consists of removing the fouling resulting from firing to obtain a chemically clean surface, and then coating this surface with a film of oil to prevent rusting.

1325. Kinds of fouling. The fouling which results from firing is of two kinds—the *powder fouling*, from the burning of the powder; and the *metal fouling*, from the nickel scraped off the bullet as it passes through the bore.

The *powder fouling* is highly corrosive, that is, it causes rust and eats into the metal, and it must, therefore, be removed as soon as possible.

The *metal fouling* itself will not cause rust, but it may cover the powder fouling and thus prevent the cleaning material from getting at the powder fouling, which, as stated before, will eat into the metal. When metal fouling accumulates in noticeable quantities it reduces the accuracy of the

[Pg 448]

rifle.

1326. How to remove powder fouling. Powder fouling may be readily removed by scrubbing the bore with the soda solution (hot) furnished by the Ordnance Department, but this solution has no effect on the metal fouling.

It is, therefore, necessary to remove all metal fouling before we are sure that all powder fouling has been removed and that the bore may be safely oiled.

Ordinarily, after firing a barrel in good condition, the metal fouling is so slight as to be hardly perceptible, and is easily removed by solvents.

However, due to the accumulation of metal fouling, pitting (little hollows in the metal) or the presence of dust, or other abrasives (substances that cause the metal to wear away by rubbing), the fouling may occur in clearly visible flakes or patches and be much more difficult to remove.

1327. How to remove metal fouling. After scrubbing out the bore with the soda solution, plug it from the breech with a cork at the front end of the chamber or where the rifling begins.

Slip one of the 2-inch sections of rubber hose over the muzzle down to the sight and fill with the standard Ordnance Department solution to at least one-half inch above the muzzle of the barrel.

Let it stand for 30 minutes, then pour out the solution, remove the hose and breech plug, and swab out thoroughly with soda solution to neutralize and remove all trace of ammonia and powder fouling.

Wipe the barrel clean, dry, and oil.

With few exceptions, one application is sufficient, but if all fouling is not removed, repeat the operation.

Hoppe's Nitro Solvent No. 9 will accomplish the same result even better and quicker and with much less labor.

1328. How to proceed in cleaning the bore.

To clean the bore after firing, proceed as follows:

Swab out the bore with soda solution to remove powder fouling. A convenient way to do this is to insert the muzzle of the rifle into the can containing the solution and with the cleaning rod inserted from the breech, pump the barrel full a few times.

Remove and dry with a couple of patches of cloth. Examine to see whether any patches of metal fouling are in evidence, and if so, then remove same as explained above. If no metal fouling is in evidence, then swab out with the swabbing solution. The amount of swabbing required with the swabbing solution can be determined only by experience assisted by the color of the patches of cloth. Ordinarily a couple of minutes' work is sufficient. Dry thoroughly, and oil with 3-in-One.

As a measure of safety a patch should *always* be run through the bore on the next day and the bore examined to insure that cleaning has been properly done. The bore should then be oiled again with 3-in-One.

1329. Necessity for preventing formation of pits. It is a fact recognized by all that a highly polished steel surface rusts much less easily than one which is roughened; also that a barrel which is pitted fouls much more rapidly than one which is smooth. Every effort, therefore, should be made to prevent the formation of pits, which are merely enlarged rust spots, and which not only affect the accuracy of the piece but also increase the labor of cleaning.

[Pg 449]

If swabbing solution or standard metal fouling solution is not available, the barrel should be scrubbed as already described, with the soda solution, dried, and oiled with a light oil. At the end of 24 hours it should again be cleaned, when it will usually be found to have "sweated." Usually a second cleaning is sufficient, but to insure safety it should be again examined at the end of a few days, before final oiling.

Of course, the swabbing solution should always be used, if available, for it must be remembered that **each "puff" when the bore "sweats" is an incipient rust pit.**

What has just been said contemplates the use of the solutions furnished by the Ordnance Department. However, the same result will be obtained with less labor by using Hoppe's Nitro Powder Solvent No. 9, which is sold by all post and camp exchanges, and which the Author, as the result of experience, highly recommends.

1330. How to oil a barrel. The proper method of oiling a barrel is as follows:

Wipe the cleaning rod dry; select a clean patch of cloth and smear it well with sperm or warmed cosmic oil, being sure that the cosmic has soaked into the patch well; scrub the bore with patch, finally drawing the patch smoothly from the muzzle to the breech, allowing the cleaning rod to turn with the rifling. The bore will be found now to be smooth and bright so that any subsequent

rust or "sweating" can be easily detected by inspection. (By "sweating" is meant, rust having formed under the coating of metal fouling where powder fouling was present, the surface is puffed up.)

1331. Care of the chamber. The chamber of the rifle is often neglected because it is not readily inspected. Care should be taken to see that it is cleaned as thoroughly as the bore. A roughened chamber delays greatly the rapidity of fire, and not infrequently causes shells to stick.

1332. The bolt. To clean the bolt, remove; clean all parts thoroughly with an oily rag; dry, and before assembling *lightly* oil the firing pin, the barrel of the sleeve, the striker, the well of the bolt, and all cams.

1333. The sights. Both the front and rear sights should be cared for just as you would care for the works of your watch. If the sights are injured, the rifle will not shoot as aimed.

The front sight cover issued by the Ordnance Department protects the front sight.

1334. The magazine. The magazine should be kept clean and covered with a thin coat of oil.

1335. The stock. The stock should receive a light coat of raw linseed oil once a month, or after any wetting from rain, dew, etc. The oil should be thoroughly rubbed in with the hand.

1336. Care of the mechanism. When the rifle has been wet or exposed to unfavorable climatic conditions, the bolt should be withdrawn and all working parts carefully wiped with a dry cloth, and then gone over with an oily rag.

[Pg 450]

The same thing should be done after firing.

All working parts should habitually be *lightly* oiled with a thin-bodied oil, such as "3-in-One."

1337. The care of all metal parts. All metal parts of the rifle should be kept clean and free from rust.

1338. Cams and bearings. All cams and bearings must be kept constantly oiled.

1339. How to apply oil. Do not pour or squirt oil on the rifle.

Put a few drops on a piece of clean cloth, preferably cotton, and rub with the cloth, thereby avoiding the use of an unnecessary amount.

Cams and bearings can be oiled this way. However, if the oiler is used instead because of greater ease in reaching them, oil them *lightly*. To soak with oil accomplishes no more than to cover with a light coating—it merely results in excessive, undesirable smearing and a waste of oil.

Remember

1340. 1. It is easier to prevent than to remove rust.

2. To remove rust, apply oil with a rag, and let it stand for a while so as to soften the rust; then wipe with a dry rag.

3. Emery paper or a burnisher must never be used in removing rust, for it also removes the bluing.

However, an ordinary rubber eraser will be found very serviceable for removing rust.

4. To prevent rust and dirt in the bore, run a rag through at least once each day.

5. Never, under any circumstances, put away a rifle that has been fired or exposed to bad weather, without first cleaning it.

6. Never lay your rifle flat on the ground. Not only is there danger of dirt or other foreign matter getting into the bore, but a vehicle may run over it, or some one may step on the sight. Always rest it up *securely* against something. On the target range it is well for every soldier to have a short wood or metal fork, on which to rest his rifle.

7. In coming to the order from any position, always bring the rifle to the ground *gently*.

Army Regulations Regarding the Rifle

1341. *Are enlisted men allowed to take their arms apart?*

No; not unless they have the permission of a commissioned officer, and even then only under proper supervision and in the manner prescribed in the descriptive pamphlet issued by the Ordnance Department. (A. R. 292.)

(Except when repairs are needed, the following named parts should never be dismantled by the soldier, and whenever they are taken apart they should be removed only by the company mechanic, or someone else familiar with the handling of tools and delicate mechanism: Bolt stop, cut off, safety lock, sleeve lock, front sight, front sight movable stud, lower band, upper band, and stacking swivel screws.)

(Unless the screw driver is handled carefully and with some skill the screws are sure to be injured either at the head or thread. The soldier may dismantle the bolt and magazine mechanism for the purpose of cleaning them, but he is not permitted to do any further dismantling without the authority of a commissioned officer.)

Is the polishing of blued and browned parts permitted?

No, and rebluing, rebrowning, putting any portion of an arm in fire, removing a receiver from a barrel, mutilating any part by fire or otherwise, and attempting to beautify or change the finish, are prohibited. However, the prohibition of attempts to beautify or change the finish of arms is not construed as forbidding the application of raw linseed oil to the wood parts of arms. This oil is considered necessary for the preservation of the wood, and it may be used for such polishing as can be given when rubbing in one or more coats when necessary. The use of raw linseed oil only is allowed for redressing and the application for such purpose of any kind of wax or varnish, including heelball, is strictly prohibited. (Army Regulations 292.)

Is the use of tompons^[17] in small arms permitted?

No, it is prohibited by regulations. (Army Regulations 292.)

Should pieces be unloaded before being taken to quarters or tents?

Yes, unless it is otherwise ordered. They should also be unloaded as soon as the men using them are relieved from duty. (Army Regulations 292.)

Should a loaded or unloaded rifle or revolver ever be pointed at anyone in play?

No, under no circumstances whatsoever. *A soldier should never point a rifle or revolver at a person unless he intends to shoot him.*

Description

1342. Nomenclature of the rifle. The illustrations on this page and those on the two following pages give the nomenclature of the rifles, with which every soldier should be familiar.

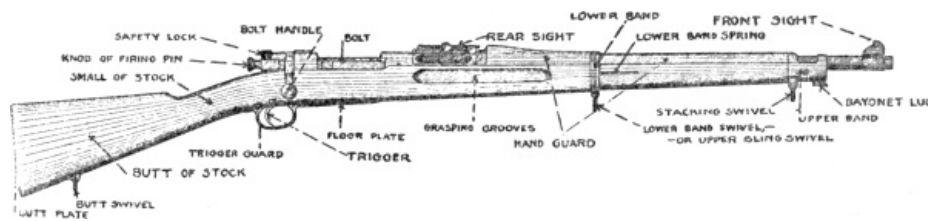

Fig. 1

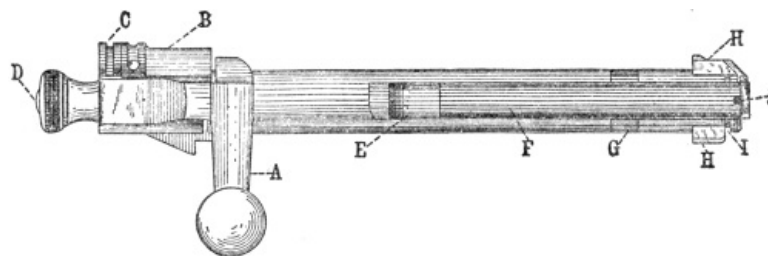

Fig. 2

The bolt (Fig. 2) consists of the *handle, A; sleeve, B; safety lock, C; Cocking piece, D; safety lug, E; extractor, F; extractor collar, G; locking lugs, H; extractor tongue groove, I; and gas escape hole, J.*

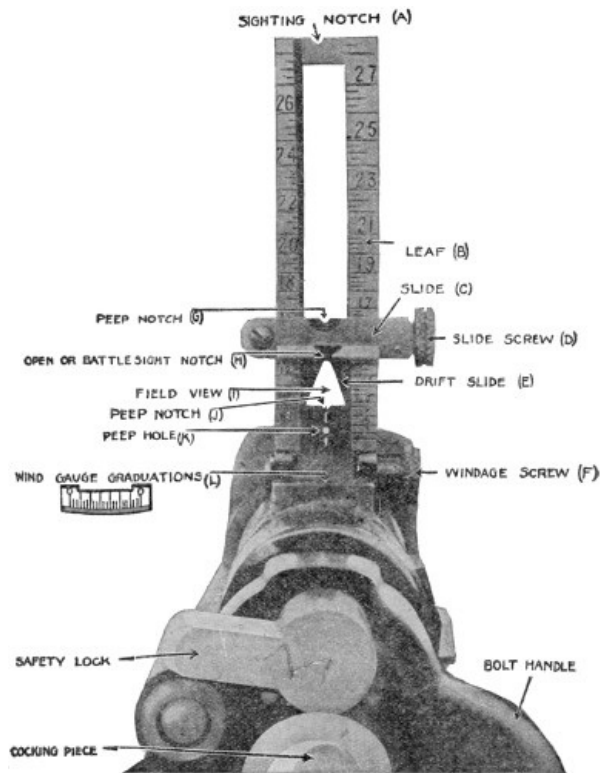

Fig. 3

1343. Rear-sight leaf; drift slide; wind gauge. The illustration on the opposite page shows the *rear sight leaf* (raised), the *drift slide* (E), and the *wind gauge* (F, L.). It is most important that the soldier be thoroughly familiar with the use of these parts, for otherwise it is impossible for him to sight correctly and use his rifle properly.

[Pg 454]

The leaf is graduated from 100 to 2850 yards. The lines that extend the whole way across the two branches of the leaf, mark 100 yard divisions; those that extend about half way across, mark 50 yard divisions, and the shorter lines mark 25 yard divisions.

The *even* numbers (4, 6, 8, etc.) on the *left* branch of the leaf, indicate 400, 600, 800, etc, yards.

The *odd* numbered hundreds of yards (300, 500, 700, etc.) are on the *right* branch of the leaf.

The numbers rest on top of the lines to which they refer.

So, if you want to fire at a target 800 yards away, set the rear sight at 8; 1,000 yards, at 10; 1,200 yards, at 12, etc.

With the fly leaf up, ranges from 100 to 2350 yards can be obtained through the *peep hole*, K; from 100 to 2450 through the lower *peep notch*, J; and from 1400 to 2750 yards through the upper *peep notch*, G.

There is a horizontal line on the drift slide, across the *peep hole*, K. If the *peep hole* sight is used the sight is set by this horizontal line, which is set opposite the proper graduation (line across branch of leaf).

If the *peep notch*, J, is used, the sight is set by the short horizontal line—that is, on a line with the top of the notch.

If the *peep notch*, G, is used, the sight is set by the top of the *slide*, C, which is set on the proper graduation.

Care must be taken not to use one of the *peep notches* when the sight has been set for the *peep hole*, or not to do the reverse, without first changing the sight.

The *sighting notch*, A, used when the range is 2850 yards, is hardly ever used, because the rifle is very, very seldom, if ever, fired at that range.

By *battle sight* we mean the position of the rear sight with the leaf down, and it corresponds to a sight setting of 530 yards. The notch, H, that is used when the leaf is down is called the *battle sight notch*. The battle sight is the only one used in *rapid fire*. In unexpected, close encounters the side that first opens a rapid and accurate fire has a great advantage over the other.

[Pg 455]

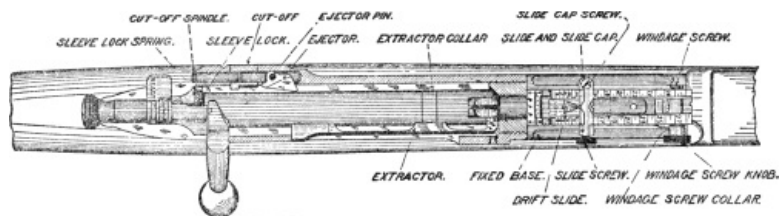

Fig. 4

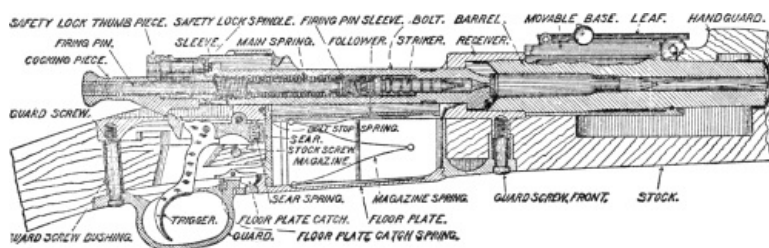

Fig. 5

FOOTNOTES:

- [17] Wooden stoppers or plugs that are put into the muzzles of rifles and other arms to keep out dirt and water.

PART IV

[Pg 456]

RIFLE TRAINING AND INSTRUCTION

[Pg 457]

(Based on Small-Arms Firing Manual)

1344. Object of system of instruction. The object of the system of rifle training and instruction employed in our Army is two-fold:

1. To make of *INDIVIDUALS*, shots who in battle will make hits instead of misses.
2. To make of *ORGANIZATIONS*, pliable, manageable *MACHINES*, capable of delivering in battle a volume of *EFFECTIVE* fire.

1345. To make of INDIVIDUALS shots who in battle will make hits instead of misses. This is accomplished by *INDIVIDUAL* training and instruction whereby the skill of the soldier as a rifleman is so developed as to be up to the capabilities of his rifle, which is probably the best and most accurate rifle in the world,—that is to say—

Effort is made to so develop the shooting skill of the soldier that he will be able to make his rifle do the things that it is capable of doing.

To accomplish this end the soldier is put through a course of individual instruction that divides itself into three main phases or stages, viz:—

1. *Preliminary drills.* By means of preliminary drills in the form of sighting drills; position and aiming drills; and deflection and correction elevation drills, he is taught the theoretical, fundamental principles of shooting.
2. *Gallery practice.* Having been taught the theoretical, fundamental principles of shooting by means of the preliminary drills mentioned in the proceeding paragraph, the soldier is then shown how to apply them in a simple, elementary way by being put through a course of gallery practice with the .22 Cal. Gallery Practice Rifle, using reduced charges. This practice may be called the *transitory* phase or period of individual instruction, during which The soldier passes from his acquisition of the theoretical, fundamental principles of shooting to their application to actual firing, on the target range, with the regulation Army rifle.
3. *Range practice.* Having gone through the course in gallery practice, the soldier then fires on the target range, applying and putting into practice, with the regulation Army rifle; the theoretical principles of shooting taught him during the preliminary drills, and in the application and practice of which he was also instructed during the gallery practice.

1346. Other Instruction. While the above phases embody the principal subjects in which a

soldier is trained and instructed in developing his skill in shooting, he is also instructed in other matters that are necessary to round out and complete his skill in marksmanship,—for example, the care of the rifle, estimating distances, the effect of light, wind, and temperature, etc.

1347. To make of ORGANIZATIONS pliable, manageable MACHINES, capable of delivering in battle a volume of EFFECTIVE fire. This is accomplished by *collective* training and instruction, in which a number of soldiers (for example, a squad, platoon, or company), under command of a leader, fire, under assumed tactical situations, at targets which simulate the appearance of an enemy under conditions approaching those found in war. This kind of training and instruction is called, "Combat practice."

In combat practice the individual is trained in firing as part of a tactical unit,—that is to say, in coöperation with others,—and the commanders of the tactical units are taught how to direct and control the fire of their units,^[18] obtaining the maximum efficiency of fire by coördination of the skill and efforts of all the individuals of the unit.

PROGRAM OF INSTRUCTION

1348. The following outline of the program of instruction gives a sort of bird's-eye view of the system:

1. INDIVIDUAL INSTRUCTION
- | | | |
|-------------------------|---|---|
| 1. Sights and Sighting. | [| (a) Theory of sighting. (The trajectory; The line of sight; Sighting or aiming.)
(b) Kinds of sights. (Open; Peep; Battle.)
(c) Kinds of sight. (That is, amount of front sight taken.) (Normal; Fine; Full.) |
| 2. Preliminary drills. | [| (a) Sighting drills. (Importance and purpose; Point of aim; Triangle of sighting.) (Verifying the triangle; causes of errors.)
(b) Position and aiming drills. (Objects [3]; Position exercise; Aiming exercise; Trigger-squeeze exercise; Rapid-fire exercise; Kneeling, sitting down, and prone.)
(c) Deflection and elevation correction drills. |
3. Gallery practice. (Object and importance.)
4. Range practice. (Instruction practice; Range practice.)
5. Other Instruction. (Use of sling; Designation of winds; Zero of rifle; Estimating distances [with the eye, by trial shots, and by trial volleys]; Wind; Temperature; Light; Mirage; Care of rifle, etc.)

INDIVIDUAL INSTRUCTION

Sights and Sighting

Theory of Sighting

1349. The trajectory. As the bullet passes through the air it makes a curved line something like this:

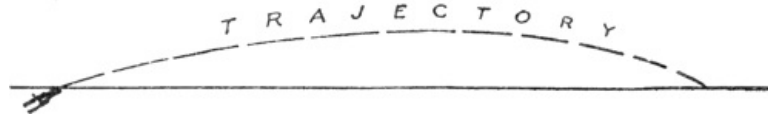

Fig. 1

This curved line is called the *trajectory*.

The resistance of the air and the force of gravity (the force that pulls all bodies toward the earth) are the two things that make the path of the bullet a curved line, just the same as they make the path of the baseball thrown by the player a curved line.

The resistance of the air holds the bullet back and the force of gravity pulls it down, so that the two acting together make the bullet's path curved.

The longer the range the more will the path of the bullet (the trajectory) be curved, as shown by the following drawing:

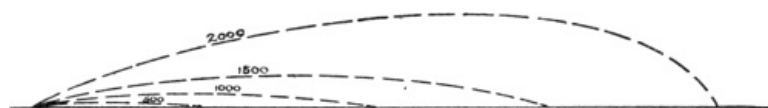

Fig. 2

1350. Sighting or aiming. Now, on the rifle there are two "sights,"—the *front sight* and the

rear sight,—which enable the rifleman to regulate the path of the bullet, as the ball player regulates the path of the ball.

If the ball player wants distance, he throws the ball high (raises the path, the trajectory), using his eye and guesswork, and likewise if the rifleman wants to shoot at a distant target, he, too, shoots the bullet high (that is, he raises the muzzle of his rifle), but he doesn't have to depend upon guesswork. It is all worked out for him by experts and all he need do is to set the *rear sight* for the proper range,—that is, for the distance the object is from him.

Aiming or sighting a rifle consists in bringing into line three objects: *The target, A, the front sight, B, and the rear sight, C.*

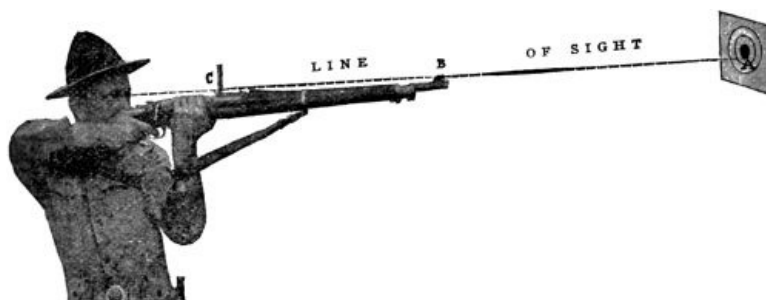

Fig. 3

The rifle is so made and the sights placed on it in such a way that when the piece is held in such a position that the *target, the front sight and the rear sight* are in line, and the trigger is pulled (squeezed) the bullet will strike the *target*.

You raise the muzzle of the piece by raising the rear sight,—that is, raising the rear sight has the effect of raising the muzzle, for the higher you raise the rear sight the higher must you raise the muzzle in order to see the front sight and get it in line with the object aimed at and the rear sight.

[Pg 460]

This is shown in the following illustrations:



Fig. 4

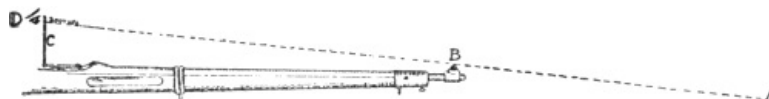

Fig. 4a

The rear sight, C, the front sight, B, and the bull's eye, A, are all on a line with the eye, D, the rear sight being set for 200 yards.

Suppose we wanted to shoot at 2000 instead of 200 yards. We would raise the slide up to 20 (2000 yards) on the sight leaf.

In order to see the bull's eye through the notch sight at 2000, we must raise the eye to the position, D. We now have the rear sight, the bull's eye and the eye in line, but we must bring the front sight in line with them, which is done by raising the muzzle of the piece, giving the result shown in [Fig. 4a](#).

1351. Line of sight. With the open sight the line of sight is determined by a point on the middle line of the notch of the rear sight and the top of the front sight.

With the peep sight, the line of sight is determined by the *center* of the peep and the top of the front sight.

Kinds of sights

1352. (See [Fig. 3](#), [par. 1343](#), giving rear sight leaf in detail.)

The different kinds of sights are as follows:

(a) **Open sight.** By *open sight* is meant the use of any one of the *sighting notches*.

To use the open sight:

1. Look through the sighting notch at the target. ([Fig. 5](#).)



Fig. 5

2. Bring the top of the front sight *on a line with the top and in the center of the sight notch, the top of the front sight being just under the bull's eye.*

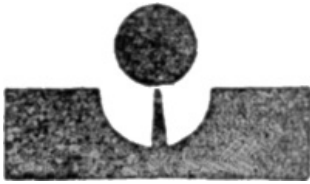

Fig. 6

Because of its wide field of view and its readiness in getting a quick aim with it, the open sight is the one that is generally used in the later stages of battle, or when fire is to start immediately.

(b) **Peep Sight.** By *peep sight* is meant the use of the *peep hole* in the drift slide.

[Pg 461]

To use the peep sight:

1. Look through the peep hole at the target. ([Fig. 7.](#))



Fig. 7

2. Bring the top of the front sight to the *center* of the peep hole, *the top of the front sight being just under the bull's eye.* ([Fig. 8](#))



Fig. 8

Correct

Be sure to get the top of front sight, as in [Fig. 8](#), and not the bull's eye, as in [Fig. 9](#), in center of the peep hole.

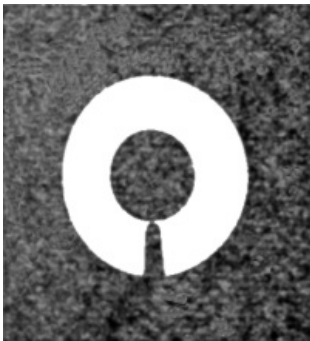

Fig. 9

Incorrect

Advantage of the peep sight. The advantage of the peep sight over the open sight is due to the fact that it is easier to center the top of the front sight in the peep hole and thus get the same amount of front sight each time.

For example you know at once, without measuring, that the dots in the circles, [Fig. 10](#), are not

centered, and that the one in the circle in [Fig. 11](#), is.

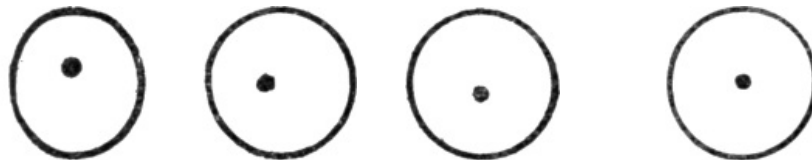

Fig. 10

Fig. 11

After a little practice, in looking through the peep hole the eye almost automatically centers the top of the front sight.

Disadvantage of the peep sight. The disadvantage of the peep sight is that its limited field of view and lack of readiness in getting a quick aim with it limit its use to those stages of the combat when comparative deliberation will be possible.

(c) **Battle sight.** By *battle sight* we mean the position of the rear sight with the leaf down. There is a sighting notch on the top of the leaf, or rather on top of the leaf slide which works up and down the leaf.

The battle sight is the only sight used in *rapid fire*. In unexpected, close encounters the side that first opens a rapid and accurate fire has a great advantage over the other. Again, a soldier on patrol generally has no time to set his sight, if suddenly attacked at close range. The battle sight, may, therefore be called the *emergency sight*,—the *handy, quick sight*. The soldier should, therefore, become thoroughly familiar with the use of this sight.

[Pg 462]



Fig. 12
Battle sight

The *sighting notch* in the slide with the rear sight leaf down, is the same height as is the sighting in the drift slide when the rear sight leaf is raised and set at 530 yards.

That is to say, *battle sight* is equivalent to a sight setting of 530 yards. Therefore, in shooting with battle sight at objects nearer than 530 yards you must aim lower.

Kinds of Sight

1353. (Amount of front sight taken)

(a) **Normal sight.** The amount of front sight taken in [Figs. 6](#) and [8](#), is called the *normal* sight and is the one that the soldier should always use, either with the open notch or peep sight, as it is the only sight which assures the taking of the same amount of front sight every time. In other words it assumes a greater degree of *uniformity* in sighting, which is one of the most important factors in shooting. By uniformity in sighting is meant taking the same amount of sight each time.

If you take *less* than the amount of front sight used in the normal sight, it will, of course, have the effect of *lowering* the muzzle of the piece, and consequently you will hit a point *lower* than if you had used the normal sight.

On the other hand, if you take *more* than the amount of front sight used in the normal sight, it will, of course, have the effect of raising the muzzle and consequently you will hit a point *higher* than if you had used the normal sight.

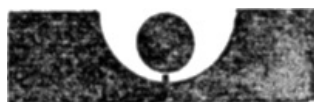

Fig. 13
Fine sight

(b) **Fine sight.** Although occasionally a man will be found who can get good results by using the fine sight, the average man cannot, and this form of sighting is, therefore, to be avoided.

(c) **Full sight.** The so-called *full sight* must be avoided under all circumstances. It is merely mentioned and shown here to point out a fault that must be carefully



Fig. 14
Full sight

avoided.

The objections to its use are the same as in the case of the fine sight,—that is, lack of uniformity in the amount of sight taken.

1354. What the rifleman looks at when he fires. The eye can be focused accurately upon objects at only one distance at a time; all other objects we see will be more or less blurred and fuzzy looking, depending upon their distance from the object upon which our eye is focused.

[Pg 463]

The rifleman who attains proficiency *focuses his eye on the target while aiming*, but he glances at one sight and then the other to see that they are aligned properly, then back at the target, and at the instant of discharge *his eye is on the target*.

Preliminary Drills

1355. Sighting, Position and Aiming Drills. The importance of the following sighting, position and aiming drills cannot be overestimated. If they are carefully practiced, before firing a single shot at a target, you will have learned how to aim your piece correctly, hold your rifle steadily, squeeze the trigger properly, assume that position best adapted to the particular conformation of your body, and you will also have acquired the quickness and manual skill required for handling the piece in rapid fire.

The sighting, position and aiming drills teach the fundamental principles of shooting, which are the foundation upon which marksmanship is built.

Do not confine yourself to going through these drills only during drill hours, but go through them frequently at other times. The extent to which it will improve your shooting will more than repay you for your trouble.

Sighting Drills

1356. Object. The objects of the sighting drill are:

1. To show how to bring the rear sight, the front sight and the target into the same line,—that is, to show how to sight properly.
2. To discover and point out errors in sighting.—in other words, to discover the errors you make in sighting and show the reasons for same, so that you may be able to correct them properly.
3. To teach uniformity in sighting,—that is, to teach you how to take the same amount of sight each time,—to see every time the same amount of front sight when you look through the rear sight.

Sighting rest for rifle. A good sighting rest for a rifle may be made by removing the top from an empty pistol ammunition box, or a similar box, and then cutting notches in the ends of the box to fit the rifle closely. ([Fig. 15.](#))

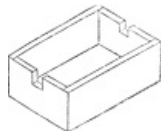

Fig. 15

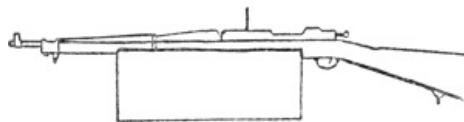

Fig. 16

Place the rifle in these notches with the trigger guard close to and outside one end.

At a convenient distance above the ground fasten a blank sheet of paper on a wall or on a plank nailed to a stake driven into the ground.

Three legs are fastened to the rest (or it may be placed on the ground without any legs), which is placed 20 or 30 feet from the blank sheet of paper.

Make sure that the piece is canted neither to the right nor left, and without touching the rifle or rest, sight the rifle near the center of the blank sheet of paper ([Fig. 17.](#))

[Pg 464]

[Pg 465]

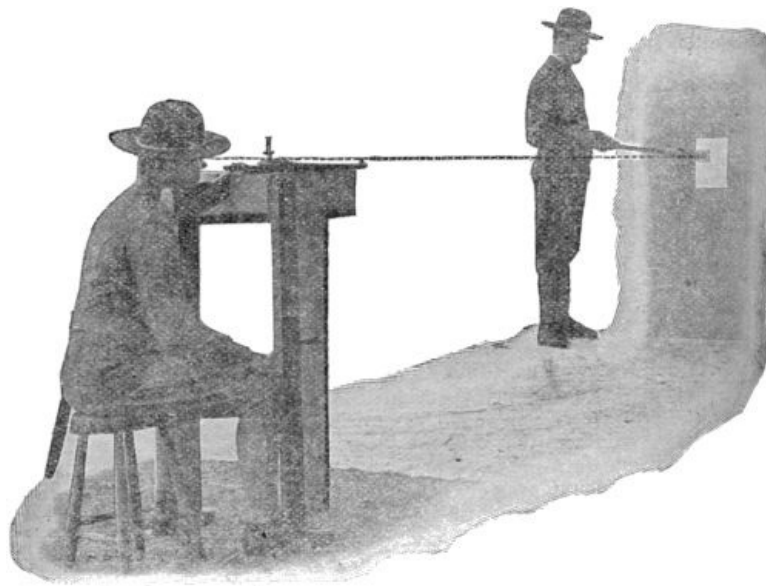

Fig. 17

Changes in the line of sight are made by changing the elevation and windage.

A soldier acting as marker is provided with a pencil and a small rod bearing at one end a small piece of white cardboard, with a black bull's eye pierced in the center with a hole just large enough to admit the point of a lead pencil.

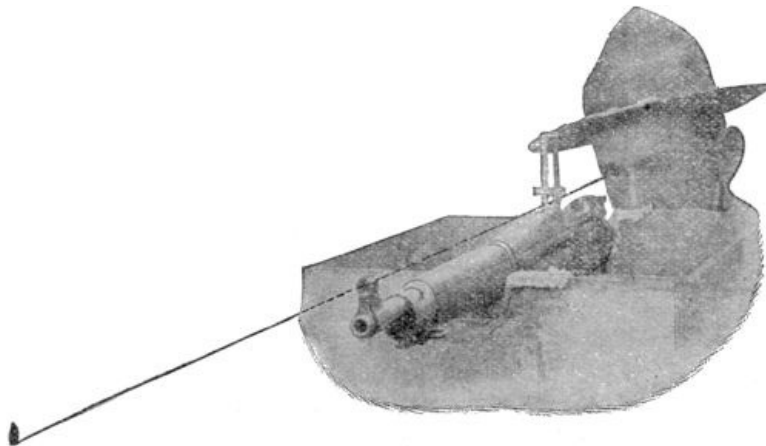

Fig. 18

The soldier sighting directs the marker to move the disk to the right, left, higher, or lower, until the line of aim is established when he commands, "Mark," or "Hold."

At the command "Mark," being careful not to move the disk, the marker records through the hole in the center the position of the disk and then withdraws it.

At the command "Hold," the marker holds the disk carefully in place without marking, until the position is verified by the instructor, and the disk is not withdrawn until so directed.

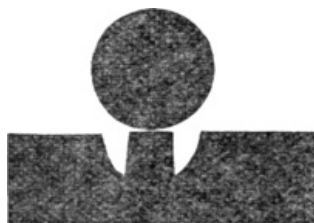

Fig. 19

1357. Point of Aim. Always be sure to aim at a point just below the black bull's-eye,—that is, aim so that there will be a fine line of light between the bottom of the bull's-eye and the-top of the front sight (Fig. 19). This is important to insure uniformity in sighting,—that is, in order to make sure that you aim at the same place on the target each time. If the top of the front sight touches the bottom of the bull's-eye it is impossible to say just how much of the front sight is seen, and how far up into the bull's-eye you are.

First Sighting Exercise

1358. Using the sighting rest for the rifle (Fig. 17) require each man to direct the marker to move the disk until the rifle is directed on the bull's-eye with the *normal* sight and command, "Hold." If aiming correctly the rear sight, the front sight and the bull's-eye will look as shown in Fig. 19, above.

The instructor then verifies this line of sight. Errors, if any, will be pointed out to the soldier and another trial made. If he is still unable to sight correctly, he will be given as many more trials as may be necessary.



Fig. 20

Sometimes a man does not know how to place the eye in the line of sight; he will look over or along one side of the notch of the rear sight and believe that he is aiming through the notch because he sees it at the same time that he does the front sight. Again some men in sighting will look at the front sight and not at the object.

Repeat the above exercise, using the *peep* sight. If aiming correctly, the rear sight, the front sight and the bull's-eye will look as shown in [Fig. 20](#).

Second Sighting Exercise

1359. The triangle of sighting. Using the sighting rest for the rifle as before ([Fig. 17](#)), direct the marker to move the disk until the rifle is directed on the bull's-eye with the *normal* sight and command "Mark," whereupon the marker, being careful not to move the disk, records through the hole in its center, the position of the disk, and withdraws it. Then, being careful not to move the rifle or sights repeat the operation until three marks have been made.

Join the three points by straight lines. The shape and size of the triangle will indicate the nature of the variations made in sighting.



Fig. 21

For example, if you have taken the same aim each time, you will get a very small triangle something like this:  which resulted from taking each time this aim, for instance:



Fig. 22

A triangle like [Fig. 22](#) results from not taking the same amount of front sight each time, as shown in [Fig. 23](#).

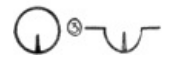
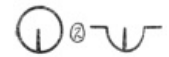
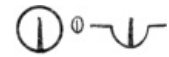

Fig. 23

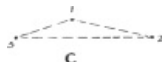

Fig. 24

A triangle like [Fig. 24](#) shows that the front sight was not in the middle of the notch each time, as shown in [Fig. 25](#).



Fig. 25



Fig. 26

A triangle like [Fig. 26](#) results from a combination of the two errors mentioned above,—that is, not taking the same amount of front sight each time and not having the front sight in the middle of the notch each time, as shown in [Fig. 27](#).

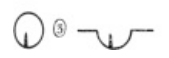
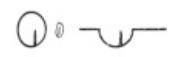

Fig. 27

[Pg 467]

If any one of the sides of the triangle is longer than one-half inch, the exercise is repeated, each sight being verified by the instructor, who will call the soldier's attention to his errors, if any.

The smaller the triangle, the better the sighting.

1360. Verifying the triangle. If the sides of the triangle are so small that they indicate regularity in sighting, mark the center of the triangle and then place the center of the bull's-eye on this mark. The instructor then examines the position of the bull's-eye with reference to the line of sight. If the bull's-eye is properly placed with reference to the line of sight, the soldier aims

correctly and with uniformity.

If the bull's-eye is not properly placed with reference to the line of sight, the soldier aims in a regular manner but with a constant error.

1361. Causes of errors. If the bull's-eye is directly above its proper position, the soldier has aimed high,—that is, he has taken too little front sight.

If the bull's-eye is directly below its proper position, the soldier has aimed low,—that is, he has taken too much front sight.

If the bull's-eye is directly to the right or left of its proper position, the soldier has not sighted through the center of the rear notch and over the top of the front sight. If to the *right*, the soldier has either sighted along the *left* of the rear sight notch or the *right* side of the front sight, or has committed both of these errors.

If the bull's-eye is to the *left* of its proper place, the soldier has probably-sighted along the *right* of the rear sight notch, or to the *left* of the front sight, or has committed both of these errors.

If the bull's eye is diagonally above and to the right, the soldier has probably combined the errors which placed it too high and too far to the right.

Any other diagonal position would be produced by a similar combination of vertical and horizontal errors.

After the above instruction has been given to one man, the line of sight will be slightly changed by moving the sighting rest or by changing the elevation and windage, and the exercises similarly repeated with other men.

[Pg 468]

Repeat the exercise, using the *peep* sight.

Third Sighting Exercise

1362. This exercise shows the effect of canting the piece.

It is most important that in aiming the sights be kept vertical and the piece not be canted,—that is, that the barrel be not tilted over to the right or left.

If the piece is canted to the right, the sights are lowered to the right and consequently the bullet will strike to the right and below the point aimed at, even though the rifle be otherwise correctly aimed and the sights correctly set.

Similarly if the piece is canted to the left the sights are lowered to the left, and consequently the bullet will strike to the left and low.

This effect of canting the piece may be shown as follows: Use the sighting rest with the rifle firmly held in the notches, the bolt removed.

Paste a black paster near the center of the bottom line of the target. Sight the rifle on this mark, using about 2000 yards' elevation. Then, being careful not to move the rifle, look through the bore and direct the marker to move the disk until the bull's-eye is in the center of the field of view and command, "Mark."

Next, turn the rest (with the rifle) over 90° to the right, on its side, and with the same elevation, sight on the same paster as above. Then, being careful not to move the rifle, look through the bore and again direct the marker to move the disk until the bull's-eye is in the center of the field of view and command, "Mark."

Not considering the fall of the bullet, the first mark represents the point struck with the sight vertical, the second mark represents the point struck, low and to the right, using the same elevation and the same point of aim, when the piece is canted 90° to the right.

Different degrees of canting the piece can be represented by drawing an arc of a circle through the two marks with the paster as a center. The second mark will be at a point on this arc corresponding to the degree of canting the piece.

It is important to know that this effect of canting increases with the distance from the target.

Fourth Sighting Exercise

1363. This exercise is to show the advantage of blackened sights.

In strong sunlight, make a triangle of sighting, using a rifle having sights worn bright. Then,

being careful not to move the rifle, blacken the sights and make another triangle.

Use dotted lines for the triangle with bright sights and full lines for the triangle made with blackened sights.

The position and size of the two triangles will plainly show the advantage of using blackened sights.

[Pg 469]

Fifth Sighting Exercise

1364. This exercise is to illustrate the importance of knowing the effects of varying degrees of light.

In strong sunlight make a triangle of sighting. Then, being careful not to move the piece, make another triangle, the target and the man sighting having first been shaded.

The relative positions of the triangles will show the importance of knowing the effects of varying degrees of light.

Position and Aiming Drills

1365. Object. The object of the position and aiming drills are:

1. To so educate the muscles of the arm and body that the piece, during the act of aiming, shall be held without restraint, and during the operation of firing shall not be deflected from the target by any convulsive or improper movement of the trigger finger or of the body, arms, or hands.
2. They also establish between the hand and eye such prompt and intimate connection as will insure that the finger shall act upon the trigger, giving the final pressure at the exact moment when the top of the front sight is seen to be directed upon the mark.
3. If at the moment the piece is discharged, it is properly supported and correctly aimed, the mark will surely be hit.

Since any fairly intelligent man can be taught to aim correctly and to hold the sights aligned upon the mark with a fair amount of steadiness, it follows that bad shooting must necessarily arise from causes other than bad aiming. The chief of these causes is known to be the deflection given to the rifle when it is discharged, due to the fact that the soldier, at the moment of firing, instead of SQUEEZING the trigger, *jerks* it. This convulsive action is largely due to lack of familiarity with the methods of firing and to a constrained position of the muscles of the body, arm, and hands, which constrained position it is the object of the position and aiming drills to correct.

1366. General. In order to correct any tendency to cant the piece, the rear sight is raised in all the exercises.

Place a black paster at which to aim on the wall opposite each man.

The squad being formed in single rank, with an interval of one yard between files, the instructor directs the men to take the position of "Ready," except that the position of the feet is such as to insure the greatest firmness and steadiness of the body.

The instructor then cautions, "Position and aiming drill."

The exercise which is being taught should be repeated frequently and made continuous. The instructor prefaces the preparatory command by, "Continue the motion," or "At will," and gives the command "Halt" at the conclusion of the exercise, when the soldier returns to the position of "Ready." Or the soldier may be made to repeat the first and second motions by the command "One," "Two," the exercise concluding with the command "Halt."

Care must be taken by the instructor not to make the position and aiming drills tedious. Thirty minutes daily should be spent in this practice during the period of preliminary instruction. After gallery practice is taken up, however, five or ten minutes daily should be sufficient for these exercises.

[Pg 470]

In order that the instructor may readily detect and correct errors the squads for these drills should not consist of more than eight men.

The instructor should avoid holding the squad in tiresome positions while making explanations or corrections.

Position Exercise

1367. The instructor commands: **1. Position, 2. EXERCISE.** At the command, "*Exercise*" without moving the body or eyes, raise the rifle smartly to the front of the right shoulder to the full extent of the left arm, elbow inclined downward, the barrel nearly horizontal, muzzle slightly depressed, heel of the butt on a line with the top of the shoulder. ([Fig. 28.](#))



Fig. 28

(Two.) Bring the piece smartly against the hollow of the shoulder, without permitting the shoulder to give way, and press the rifle against it, mainly with the right hand, only slightly with the left, the forefinger of the right hand resting lightly against the trigger, the rifle inclined neither to the right nor left.



Fig. 29

(Three.) Resume the position of ready. ([Fig. 30.](#))



Fig. 30

Remarks. The instructor should especially notice the position of each soldier in this exercise, endeavoring to give to each man an easy and natural position. He should see that the men avoid drawing in the stomach, raising the breast, or bending the small of the back. The butt of the piece must be pressed firmly, but not too tightly, into the hollow of the shoulder and not against the muscles of the upper arm. If held too tightly, the pulsations of the body will be communicated to the piece; if too loosely, the recoil will bruise the shoulder. If only the heel or toe touches the hollow of the shoulder, the recoil may throw the muzzle down or up, affecting the position of the hit. While both arms are used to press the piece to the shoulder, the left arm should be used to direct the piece and the right forefinger must be left free to squeeze the trigger.

[Pg 471]

Aiming Exercise

1368. The instructor will first direct the sights to be adjusted for the lowest elevation and subsequently for the different longer ranges.

The instructor commands: **1. Aiming. 2. EXERCISE.** At the last command execute the first and second motion of the position exercise.

(Two.) Bend the head a little to the right, the cheek resting against the stock, the left eye closed, the right eye looking through the notch of the rear sight at a point slightly below the mark. ([Fig. 31.](#))



Fig. 31

(Three.) Draw a moderately long breath, let a portion of it escape, then, with the lungs in a state of rest, slowly raise the rifle with the left hand, being careful not to incline the sight to either side, until the line of sight is directly on the mark; hold the rifle steadily directed on the mark for a moment; then, without command and just before the power to hold the rifle steadily is lost, drop the rifle to the position of "Ready" and resume the breathing.

1369. Remarks. Some riflemen prefer to extend the left arm. Such a position gives greater control over the rifle when firing in a strong wind or at moving objects. It also possesses advantages when a rapid as well as accurate delivery of fire is desired. Whatever the position, whether standing, kneeling, sitting, or prone, the piece should rest on the palm of the left hand, never on the tips of the fingers, and should be firmly grasped by all the fingers and the thumb.

[Pg 472]

The eye may be brought to the line of sight either by lowering the head or by raising the shoulder; it is best to combine somewhat these methods; the shoulder to be well raised by raising the right elbow and holding it well to the front and at right angles to the body.

If the shoulder is not raised, it will be necessary for the soldier to lower the head to the front in order to bring the eye into the line of sight. Lowering the head too far to the front brings it near the right hand, which grasps the stock. When the piece is discharged, this hand is carried by the recoil to the rear and, when the head is in this position, may strike against the nose or mouth. This often happens in practice, and as a result of this blow often repeated many men become gun-shy, or flinch, or close their eyes at the moment of firing. Much bad shooting, ascribed to other causes, is really due to this fault. Raising the right elbow at right angles to the body elevates the right shoulder, and lifts the piece so that it is no longer necessary to incline the head materially to the front in order to look along the sights.

As the length of the soldier's neck determines greatly the exact method of taking the proper position, the instructor will be careful to see that the position is taken without restraint.

As changes in the elevation of the rear sight will necessitate a corresponding change in the position of the soldier's head when aiming, the exercise should not be held with the sight adjusted for the longer ranges until the men have been practiced with the sights as the latter would generally be employed for offhand firing.

The soldier must be cautioned that while raising the line of sight to the mark he must fix his eyes on the mark and not on the front sight; the latter can then be readily brought into the line joining the rear-sight notch and mark. If this plan be not followed, when firing is held on the range at long distances the mark will generally appear blurred and indistinct. The front sight will always be plainly seen, even though the eye is not directed particularly upon it.

The rifle must be raised slowly, without jerk, and its motion stopped gradually. In retaining it directed at the mark, care must be taken not to continue the aim after steadiness is lost; this period will probably be found to be short at first, but will quickly lengthen with practice. No effort should be made to prolong it beyond the time that breathing can be easily restrained. Each soldier will determine for himself the proper time for discontinuing the aim.

The men must be cautioned not to hold the breath too long, as a trembling of the body will result in many cases.

Trigger-Squeeze Exercise

1370. The instructor commands: **1. Trigger squeeze. 2. EXERCISE.** At the command **Exercise**, the soldier executes the first motion of the aiming exercise.

(Two.) The second motion of the aiming exercise.

(Three.) Draw a moderately long breath, let a portion of it escape, hold the breath and slowly raise the rifle with the left hand until the line of sight is on the mark, being careful not to incline the sights to either side. Contract the trigger finger gradually, slowly and steadily increasing the pressure on the trigger, while the aim is being perfected; continue the gradual increase of pressure so that when the aim has become exact the additional pressure required to release the point of the sear can be given almost insensibly and without causing any deflection of the rifle. Continue the aim a moment after the release of the firing pin, observe if any change has been made in the direction of the line of sight, and then resume the position of "Ready," cocking the piece by raising and lowering the bolt handle.

Remarks. Poor shooting is often the result of lack of proper coördination of holding the breath, the maximum steadiness of aim, and the squeeze of the trigger. By frequent practice in this exercise, each man may come to know the exact instant his firing pin will be released. He must be taught to hold the breath, bring the sights to bear upon the mark, and squeeze the trigger all at the same time.

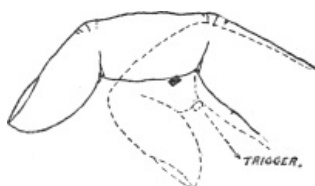

Fig. 32

1371. The Trigger Squeeze. The trigger should be *squeezed*, not pulled, the hand being closed upon itself as a sponge is squeezed, the forefinger sharing in this movement. The forefinger should be placed as far around the trigger as to *press* it with the second joint. By practice the soldier becomes familiar with the trigger *squeeze* of his rifle, and knowing this, he is able to judge at any time, within limits, what additional *pressure* is required for its discharge. By constant repetition of this exercise he should be able finally to *squeeze* the trigger to a certain point beyond which the slightest movement will release the sear. Having *squeezed* the trigger to this point, the aim is corrected and, when true, the additional pressure is applied and the discharge follows.

Rapid-Fire Exercise

1372. Object. The object of this exercise is to teach the soldier to aim quickly and at the same time accurately in all the positions he will be called upon to assume in range practice.

The instructor commands: **1. Rapid-fire exercise. 2. COMMENCE FIRING.** At the first command the first and second motions of the trigger-squeeze exercise are performed. At the second command, the soldier performs the third motion of the trigger-squeeze exercise, squeezing the trigger without disturbing the aim or the position of the piece, but at the same time without undue deliberation. He then without removing the rifle from the shoulder, holding the piece in position with the left hand, grasps the handle of the bolt with the right hand, rapidly draws back the bolt, closes the chamber, aims, and again squeezes the trigger. This movement is repeated until the trigger has been squeezed five times, when, without command, the piece is brought back to the position of "Ready."

[Pg 474]

When the soldier has acquired some facility in this exercise, he will be required to repeat the movement ten times, and finally, by using dummy cartridges, he may, by degrees, gain the necessary quickness and dexterity for the execution of the rapid fire required in range firing.

1373 Methods. The methods of taking position, of aiming, and of squeezing the trigger, taught in the preceding exercises, should be carried out in the rapid-fire exercises, with due attention to all details taught therein; the details being carried out as prescribed except that greater promptness is necessary. In order that any tendency on the part of the recruit to slight the movements of aiming and of trigger squeeze shall be avoided, the rapid-fire exercises will not be taught until the recruit is thoroughly drilled and familiar with the preceding exercises. The recruit will be instructed that with practice in this class of fire the trigger can be squeezed promptly without deranging the piece.

1374. Repetition. If the recruit seems to execute the exercise hurriedly or carelessly, the instructor will require him to repeat it at a slower rate.

1375. Manipulation of the Breech Mechanism. To hold the piece to the position of the left hand should not be changed, but the left forearm with the proper facility, are learned only after much practice. Some riflemen, especially men who shoot from the left shoulder, find it easier, in

rapid firing, to drop the piece to the position of load after each shot. While at first trial this method may seem easier, it is believed that, with practice, the advantage of the former method will be apparent.

Position and Aiming Drill, Kneeling

1376. These exercises will be repeated in the kneeling position by causing the squad to kneel by the commands prescribed in the Drill Regulations. The exercises will be executed as prescribed for standing, except that the command "Two" in the position exercise, the soldier will rest the left elbow on the left knee, the point of the elbow in front of the kneecap. The pasters for the kneeling exercise should be at 2¹/₂ feet from the floor or ground.

Remarks. Frequent rests will be given during practice in these exercises kneeling, as the position, if long continued, becomes constrained and fatigues the soldier unnecessarily.

In raising the rifle to the mark in the second and third exercises, the position of the left hand should not be changed, but the left forearm should be brought toward the body and at the same time the body bent slightly to the rear.

[Pg 475]

When aiming kneeling there is, from the nature of the position, a tendency to press the butt of the rifle against the upper arm instead of against the hollow of the shoulder; this will necessitate inclining the head considerably to the right to get the line of sight, and by bringing the rifle so far to the rear will, if the thumb is placed across the stock, cause it to give by the recoil a blow upon the nose or mouth.

These difficulties may be avoided by advancing the right elbow well to the front, at the same time raising it so that the arm is about parallel with the ground. The hollow of the shoulder will then be the natural place for the rifle butt, and the right thumb will be brought too far from the face to strike it in the recoil.

Some riflemen prefer, by bending the ankle, to rest the instep flat on the ground, the weight of the body coming more on the upper part of the heel; this obviates any tendency of the right knee to slip; or, by resting the right side of the foot on the ground, toe pointing to the front, to bring the weight of the body on the left side of the foot. These positions are authorized.

1377. Choice of Position. In firing kneeling, the steadiness obtained depends greatly upon the position adopted. The peculiarities of conformation of the individual soldier exert when firing kneeling a greater influence than when firing either standing, sitting, or prone; the instructor should, therefore, carefully endeavor, noticing the build of each soldier, to place him in the position for which he is best adapted and which will exert the least tension or strain upon the muscles and nerves. It should be remembered, however, that without the rest of the left elbow on the knee this position possesses no advantage of steadiness over the standing position.

1378. Kneeling Position; When Taken. The kneeling position can be taken more quickly than either the sitting or the prone position. It is, therefore, the position naturally assumed when a soldier, who is standing or advancing, has to make a quick shot at a moving or disappearing object and desires more steadiness than can be obtained standing.

Position and Aiming Drill, Sitting Down

1379. In many cases the men, while able to kneel and hold the piece moderately steady, can obtain in a sitting position much better results. All should, therefore, be instructed in aiming sitting down as well as kneeling.

To practice the soldier in the preceding exercises in a sitting position, the squad being formed in a single rank, with an interval of one pace between files, the rifle should first be brought to "Order arms"; the instructor then commands: *Sit down*.

At this command make a half face to the right and, assisted by the left hand on the ground, sit down, facing slightly to the right, the left leg directed toward the front, right leg inclined toward the right, both heels, but not necessarily the bottoms of the feet, on the ground, the right knee slightly higher than the left; body erect and carried naturally from the hips; at the same time drop the muzzle of the piece to the front, and to the position of the first motion of load, right hand upon the thigh, just in front of the body, the left hand slightly above, but not resting upon, the left leg.

[Pg 476]

The exercise will be executed as heretofore prescribed, except that at the command "Two" (position exercise) the soldier will rest the left elbow on the left knee, the point of the elbow in front of the kneecap, and the right elbow against the left or inside of the right knee, at the same time inclining the body from the hips slightly forward.

For the aiming and trigger-squeeze exercises the pasters, used as aiming points, will be 2¹/₂ feet

from the floor or the ground.

To afford the men rest or on the completion of the kneeling or sitting down exercises the instructor will command *Rise*, when the men rise, face to the front, and resume the "Order arms."

Remarks. If the preceding position is carefully practiced, steadiness is quickly attained. The right leg should not be carried so far to the right as not to afford a good support or brace for the right elbow.

This position may be modified, but, in general, not without impairing the steadiness of the man, by crossing the legs at the ankle, the outside of each foot resting upon the ground, body more erect, and the knees slightly more raised than in the previous position.

Position and Aiming Drill, Prone

1380. From the nature of the position it is not practicable to execute these exercises according to the method followed when standing or kneeling. Instruction will, however, always be given with reference to the position, to the manner of assuming it, and to aiming and squeezing the trigger.

For this purpose the squad being formed as specified above, in the position and aiming drill, sitting down (the black plasters therein mentioned being about 12 inches from the ground), the squad will be brought to "Order arms."

Then (the squad either standing or kneeling), the instructor commands: *Lie down*, which will be executed as prescribed in the Drill Regulations; the legs may be spread apart and the toes turned out if found to give a steadier position.

After the squad has taken the position as prescribed above, the legs should be inclined well to the left, and either crossed or separated as the soldier prefers or as his particular conformation appears to render most desirable, and the body at the same time inclined slightly to the right.

With care and practice the soldier may acquire an easy position which he is able to assume with great facility.

1381. Being at "Ready," the instructor then commands: **1. Trigger squeeze. 2. EXERCISE.**

At the latter command carry the left elbow to the front and slightly to the right, the left hand under the barrel at the balance, weight of the body mainly supported by the left elbow, the right resting lightly on the floor or ground.

(Two.) Slide the rifle with the right hand through the left hand to the front until the left hand is a little in front of the trigger guard; at the same time raise the rifle with both hands and press it against the hollow of the shoulder.

[Pg 477]

(Three.) Direct the rifle upon the mark and carry out the further details of aiming and squeezing the trigger as prescribed in the trigger-squeeze exercise.

Then resume the position, lying down.

As soon as the men have acquired with accuracy the details of the position, they will be practiced, without the numbers, in aiming and squeezing the trigger at will; after which the rapid-fire exercise in the prone position will be practiced, the necessary skill and dexterity being acquired by degrees.

To afford the men rest, or on completion of the exercise, the instructor will command: *Rise*, which is executed as prescribed in the Drill Regulations.

1382. Remarks. The preceding position for firing lying down possesses in a greater degree than any other position the merit of adaptability to the configuration of the ground; it enables the soldier to deliver fire over low parapets or improvised shelters, thus making the best use of cover. The importance of training the soldier in firing from the other positions should not, however, be lost sight of, since from the prone position it will frequently be impossible to see the objective.

Back positions are not authorized.

In the prone position, when aiming, the left elbow should be well under the barrel, the other elbow somewhat to the right, but not so far as to induce any tendency to slip on the floor or ground.

The greater changes in elevation required in first directing the rifle on the object should be given by altering the position of the left hand under the barrel, the slighter changes only by advancing or withdrawing the shoulder.

As the body does not yield to the recoil, as when firing standing or kneeling, the force of recoil, if the rifle is not properly held, may severely bruise the soldier. It is one of the objects of this exercise to so teach him that this will be prevented by assuming a correct position. Care must be exercised that the butt is not brought against the collar bone. By moving the shoulder slightly to the front or rear, and by moving the right elbow from the body or toward it, each soldier may determine the position in which the shoulder gives to the butt of the rifle the easiest rest. This will probably be the one in which the force of the recoil will be least felt.

The soldier should persist in this exercise until he obtains a position in which he feels no constraint, which will not subject him to bruises from recoil, and from which the mark appears plainly through the sights. Having secured such a position, he must not change it when firing, as a variation in the points of support of the rifle, the distance of the eye from the rear sight, or the tension of the hold has a decided effect, especially at the longer ranges, upon the location of the point struck.

Important. The soldier should be encouraged to go through these exercises frequently at other than drill hours, care being taken that, in the aiming and trigger-squeeze exercises, he always has some definite object for a mark.

Deflection and Elevation Correction Drills

(Sight-Setting Drills)

1383. Sight Correction. You may find when firing at a target that the first shot has missed the bull's-eye or figure. Now, one of two things may be done in order to cause the second shot to hit the bull's-eye or figure: (1) The point of aim may be changed, or (2) the sights may be moved and the same point as before aimed at.

In order to do accurate shooting it is necessary to have a well-defined mark at which to aim; consequently, except for very slight corrections, the method of moving the sights, involving changes in elevation and windage, is the one to be used.

Exercises. In order to give the soldier practice in making corrections in elevation and deflection (windage),—that is, in sight-setting,—proceed as follows:

Take an "A" target and rule it off with red vertical lines to represent range and black or blue horizontal lines to represent windage deviations, as in Fig. 33. Tell the men to set their sights (either peep or open) for 200 yards, no windage. Examine the sights (assisted by the lieutenants, noncommissioned officers and expert riflemen).

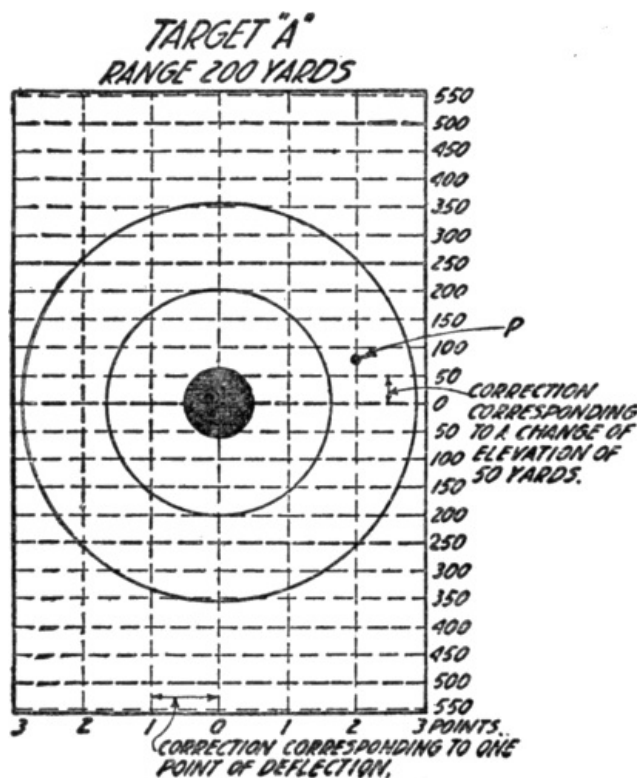

Fig. 33

Then say, for example, "You have fired a shot at 200 yards with your sights set as you now have them. The shot was marked here (pointing to 'P,' Fig. 33). Change your sights so as to move the next shot into the bull's-eye,—considering that you take the same hold as you did the last time."

(Note. In this case the sight should be lowered 75 yards and 2 points of left windage should be taken.)

Repeat with different positions for "P" until the men all understand the method and the reasons. Do same for 300 yards, 500 yards, and 600 yards. See [Figs. 34, 35, and 36.](#)

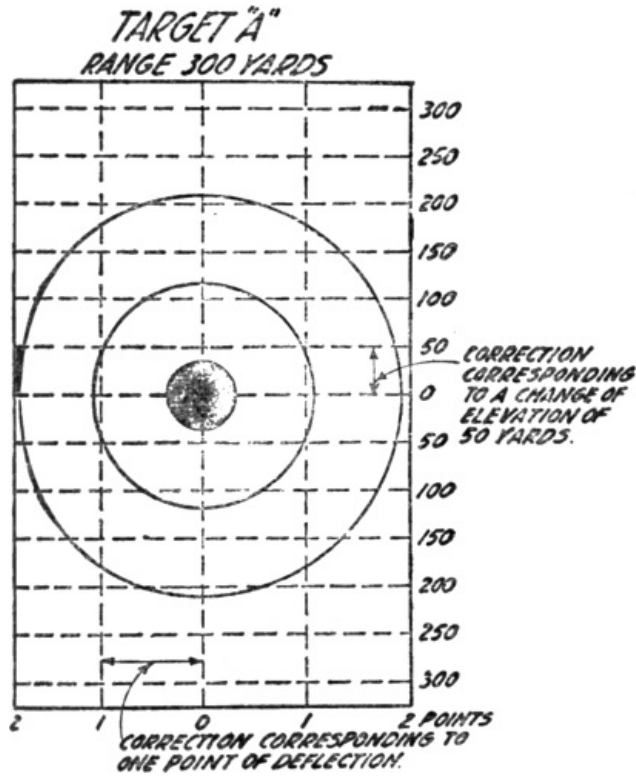

Fig. 34

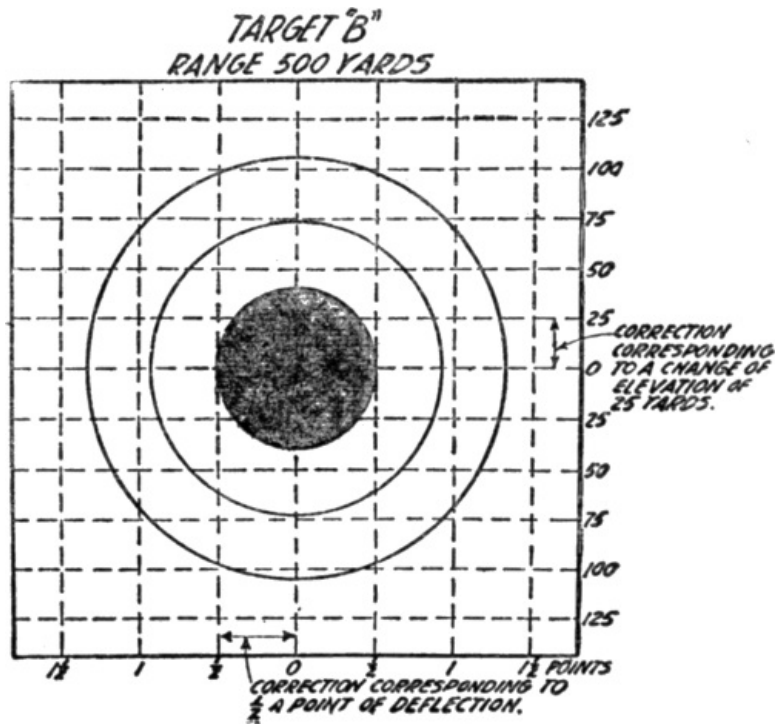

Fig. 35

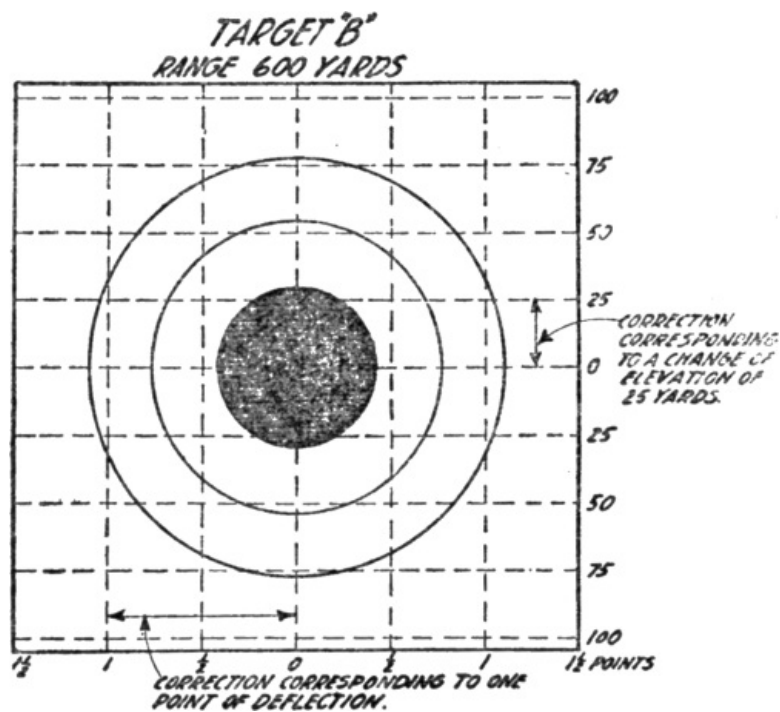

Fig. 36

Explain that in firing no change in sights should be made until the man is sure that his hold was good, and then change without hesitancy.

The correct use of sights and their proper adjustment can thus be taught without firing a shot. This exercise will save much time and work on the range.

Elevation. As previously explained, raising the rear sight increases the range of the bullet and lowering it decreases the range.

The amount of change which a given amount of elevation will cause in the point struck varies with the range and with the rifle and with the ammunition used.

For example, generally and approximately, in order, at a range of 500 yards, to change the point struck 1 foot, the rear sight must be changed 48 yards, while to change the point struck 1 foot at 1000 yards it must be changed 12 yards. That is to say, if you fired a shot at 300 yards, and then with the same aim, hold and other conditions as before, you *raised* your rear sight 48 yards, the next shot would strike the target 1 foot *above* the first one, and if you *lowered* the rear sight 48 yards, the bullet would then strike the target 1 foot *below* the first one. If firing at 1000 yards, *raising* the rear sight 12 yards would cause the bullet to strike the target 1 foot *higher* and *lowering* the rear sight 12 yards would cause it to strike 1 foot *lower*.

[Pg 480]

The following table gives the approximate changes in the rear sight to move the point struck 1 foot at ranges from 100 to 1000 yards:

Range	Correction in elevation necessary to change the point struck 1 foot
100	415
200	185
300	105
400	70
500	48
600	35
700	25
800	20
900	15
1,000	12

The score-books issued by the Ordnance Department contain elevation charts and all you have to do is to consult the chart of your score-book in order to get the amount of elevation necessary at any particular range in order to raise or lower your shots any desired distance.

1384. Deflection (windage). Corrections in the deflection (side movement) of the bullet are made by means of the windage screw that moves the movable base, each division of the graduations on the rear end of the movable base being called a "point of windage."

One point of windage moves the point struck 4 inches for each 100 yards of range.

[Pg 481]

That is to say, at 100 yards, 1 point of windage moves the point struck 4 inches; at 200 yards, 8 inches (2 × 4); at 300 yards, 12 inches (3 × 4), etc.

Consequently, if at 100 yards the wind were carrying your bullets 8 inches to the side, you would take two points of windage to get the bull's-eye, and if the wind were carrying your bullets 20 inches to the side, you would take 5 points of windage, irrespective of the rate at which the wind was blowing.

Again, if at 200 yards the wind were carrying your bullets 8 inches to the side, you would take 1 point of windage, and if it were carrying your bullets 20 inches to the side, you would take $2\frac{1}{2}$ points, irrespective of the rate at which the wind was blowing.

In using the wind gauge remember *windage is always taken in the direction from which the wind is coming (into the wind) and the bullet moves in the same direction that the rear sight moves,—that is, if the wind is coming from the right, you take right windage and the bullet will strike to the right. Likewise if you move the rear sight to the left (take left windage), the bullet will strike to the left.*

GALLERY PRACTICE

1385. Object and importance. After the soldier has been thoroughly instructed in sighting, and in the position, aiming, deflection, and elevation correction drills, he is exercised in firing at short ranges (50 and 75 feet) with the gallery practice rifle (.22 caliber).

Notwithstanding the value of the position and aiming drills, it is impossible to keep up the soldier's interest if these exercises are unduly prolonged. By gallery practice, however, the interest is easily maintained and further progress, especially in teaching the trigger squeeze, is made. Many of the external influences, which on the range affect the firing, being absent, the soldier is not puzzled by results for which, at this stage of his education, he could not account were he advanced to firing with full charges. Furthermore, as there is no recoil to induce nervousness or flinching, the soldier soon finds that he can make good scores, and this success is the surest stimulus to interest.

Not only to the beginner is gallery practice of value; to the good shot it is a means of keeping, to a certain extent, in practice, and practice in shooting, as much as in anything else, is essential. Since it can be carried on throughout the year, gallery practice is of much value in fixing in the men the *habit of aimed fire*, than which nothing in his training is of more importance.

RANGE PRACTICE

1386. Having completed the gallery practice course, the soldier is then advanced to known-distance firing on the target range where he uses the service rifle, with service ammunition.

This known-distance practice is divided into certain regular courses and special courses.

The regular courses and Special Course A are for troops of the Regular Army.

[Pg 482]

There is also a special course for the Organized Militia and Volunteers and one for Volunteer recruits.

All the various courses are described in detail in the Small-Arms Firing Manual and anyone having occasion to use any of them should familiarize himself thoroughly therewith.

OTHER INSTRUCTION

1387. Use of sling. After the soldier has been drilled in the proper standing, kneeling, sitting, and prone positions in the foregoing exercises, the use of the sling will be taught. Adjustments and their advantages will be taught with the idea of noninterference with quickness and freedom of action. The trigger squeeze exercises will then be continued in the different positions, using the sling.

1388. Description and adjustment. The sling is made up of four parts: the long strap, A, forming the arm loop; the short strap, B; and the two keepers, C and D. At one end of each of the straps there is a metal claw, used for adjusting the straps. At the other end of the short straps there is a metal loop through which the longer strap is passed, thus connecting the two straps.

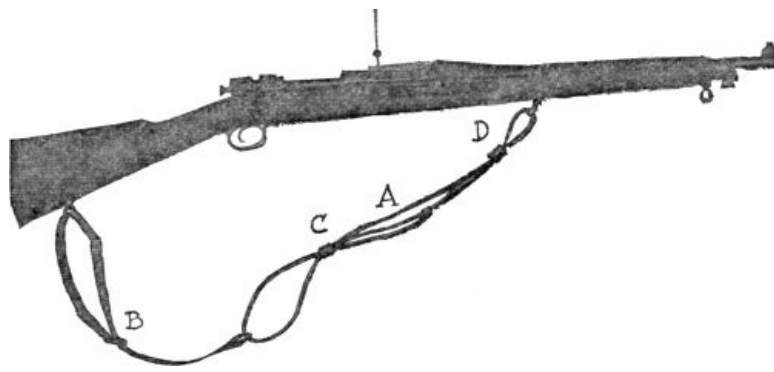

Fig. 37

To adjust the sling for firing, the claw of the short strap is disengaged and reengaged in the proper holes of the short strap, such adjustment as may be necessary being also made in the long strap (the arm loop).

1389. What the sling does. It does two things: (1) It steadies the rifle, and (2) helps to take up the recoil,—that is, to reduce the "kick."

Its use. There are a number of different methods of using the sling. Experiment with different ones until you find and decide upon the method best suited to you.

The sling should be used in all firing,—combat practice as well as at target practice.

Always adjust the sling so that it will be tight.

[Pg 483]

Have the arm loop no longer than is necessary to reach the middle of the small of the stock. When on the arm, have the lower end of the arm loop well up near the arm pit, with the keeper well pressed down so as to hold the loop fast.

Note the proper adjustments of the sling for the different firing positions,—that is, standing, sitting, kneeling, and prone, and mark the adjustments on the inside of the arm loop, "St" (standing), "Si" (Sitting), "K" (kneeling), and "P" (prone).

It is sometimes advisable to sew a piece of rope to your shirt sleeve to keep the sling from slipping down.

1390. To put on the sling. 1. Put your left hand in the loop, twisting the sling to the left, A, [Fig. 38](#), and holding the rifle with the right hand as shown in the figure. Twisting the sling to the left causes a flat surface instead of the cutting edge of the sling to rest against the wrist.

[Pg 484]

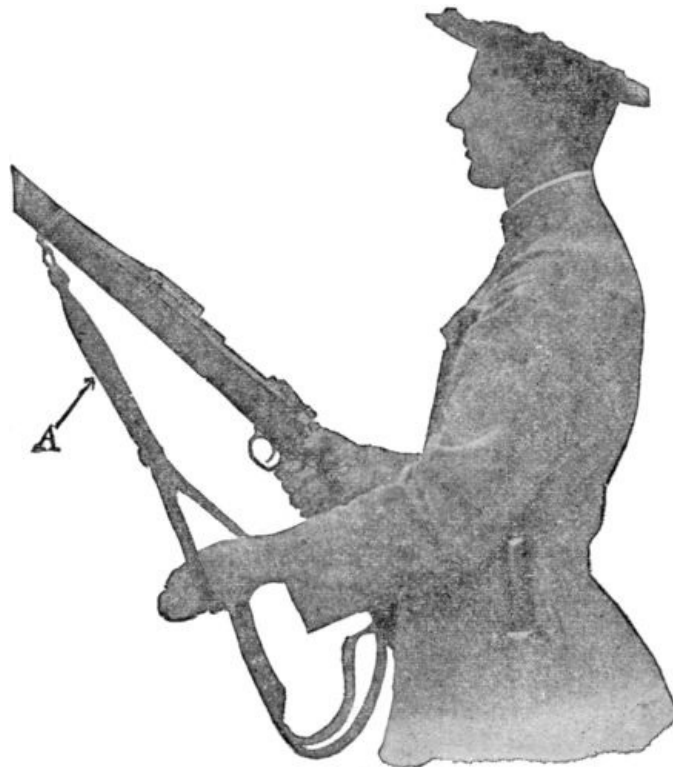

Fig. 38

2. Extend the arm on through the loop, ([Fig. 39](#)), bringing the loop well up near the pit of the arm, grasping the piece with the left hand, and pressing down keeper, A.

[Pg 485]

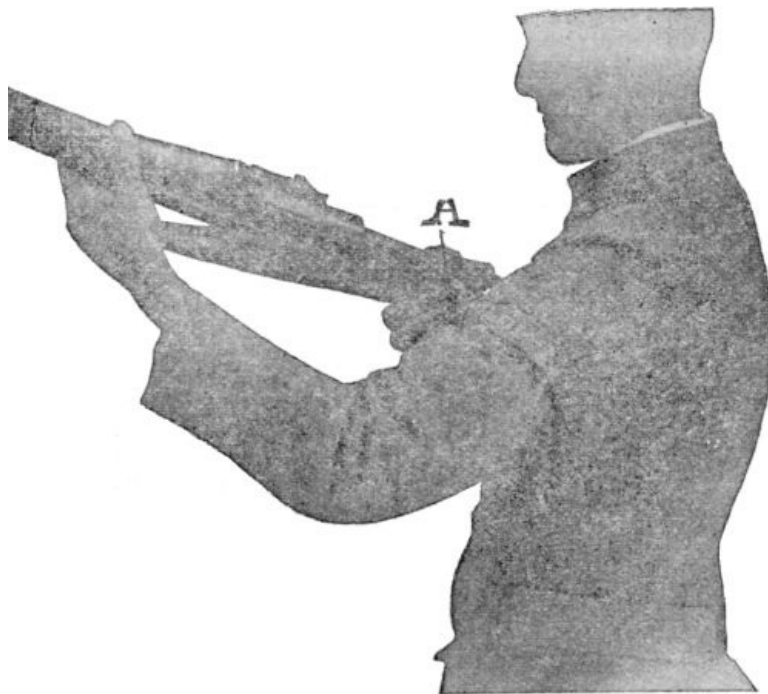

Fig. 39

3. Place left hand between the sling and piece, ([Fig. 40](#)), the hand being pressed well forward toward the upper sling swivel, A. Notice how the back of the hand is resting against the flat of the sling.

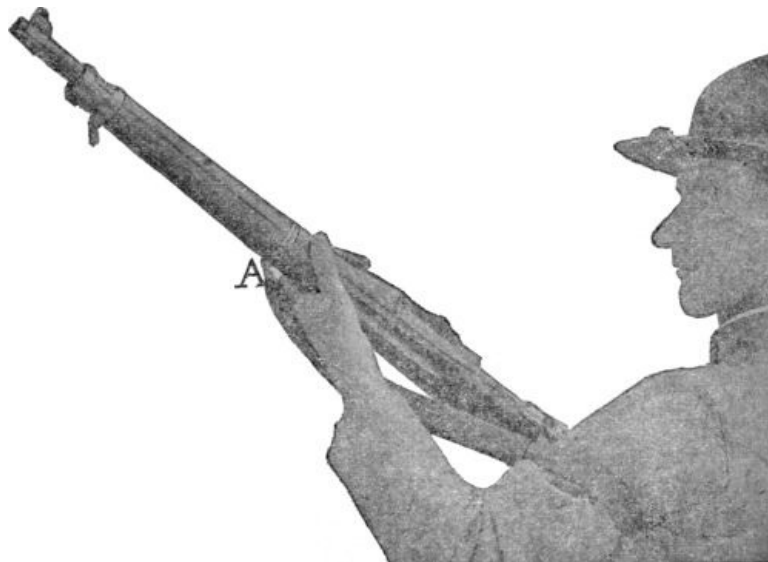

Fig. 40

4. Come to the position of aim, [Fig. 41](#). Pressure is applied to the sling by pressing forward the left hand, and holding the rifle to the shoulder with the right hand. Remember that whatever pressure you apply must be the same for each shot.

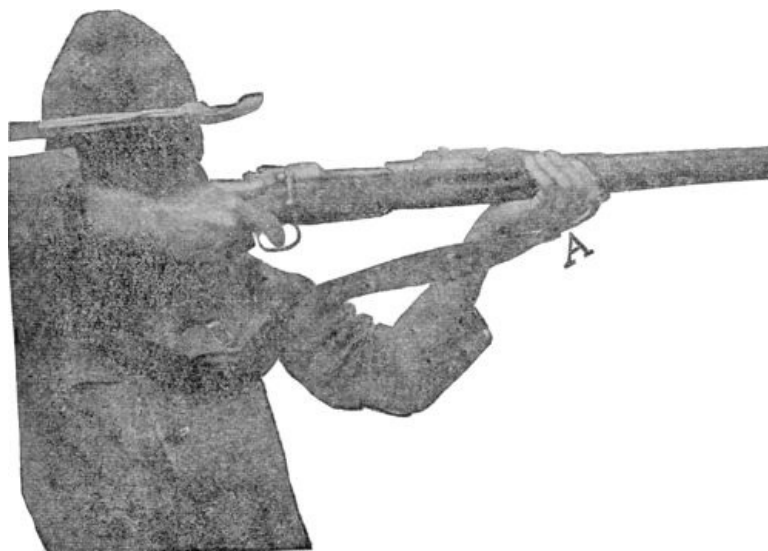

Fig. 41
Right side view

Notice (Figs. 41 and 42) how well forward the left hand is, and how the flat of the sling is resting against the wrist and back of hand. See how the short strap, C, (Fig. 41), of the sling is correctly loose.

The thumb should be held along the stock as shown (A) in Fig. 42.

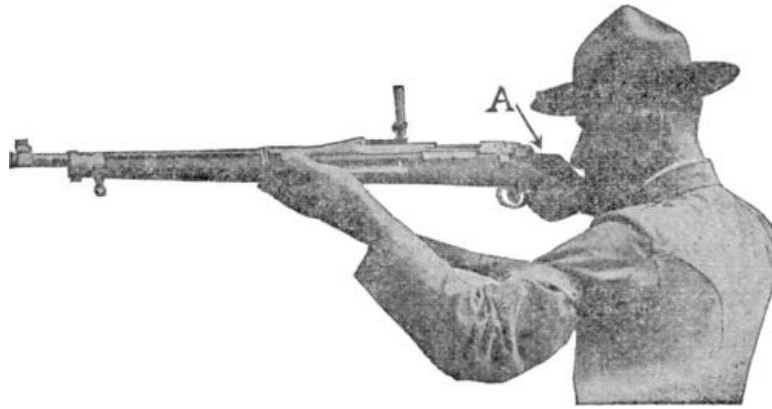

Fig. 42
Left side view

1391. Designation of winds. Winds are designated as "12 o'clock," "1 o'clock," "2 o'clock," etc., winds, depending on the direction *from* which they come.

[Pg 486]

Imagine the firing point to be in the middle of the face of a clock and the target to be at 12 o'clock; 3 o'clock will be on your right, 9 o'clock on your left, 6 o'clock in your rear and 12 in your front.

A wind blowing *from* your right to your left is called a 3 o'clock wind; one blowing *from* your rear is called a 6 o'clock wind; one from your front, 12 o'clock wind, etc.

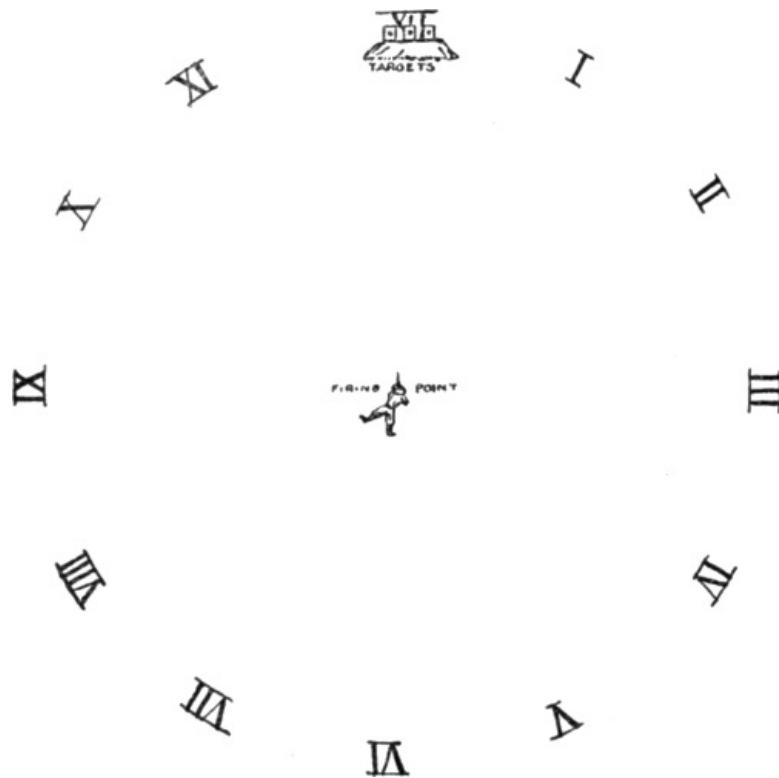

Fig. 43

The score-books issued by the Ordnance Department have windage charts that have been carefully worked out and all you have to do is this: Estimate the force of the wind in miles per hour, and determine the direction from which it comes (whether a 9 o'clock wind, a 2 o'clock wind, etc.). Then look at the windage chart and see just how much windage you must take.

The simplest and best rule for the beginner is for him to make his estimate and then ask an experienced shot what windage to use, checking this up with what he found on the windage chart. In this way he soon learns to estimate for himself.

Practice estimating the wind. Ask a man who has been making 5's and 4's what windage *he* used and check up with your own estimate.

You can find out the direction of the wind by watching smoke, grass or the limbs of trees.

Throw up some small straws and watch which way they are blown, or wet your finger and hold it

up. The wind cools the side it strikes.

A 12 o'clock wind slows up the bullet and a 6 o'clock wind helps it along,—so, in the first case you would need more elevation and in the second less elevation.

1392. The zero of a rifle. The twist of the bullet given by the rifling of the barrel causes the bullet to move to right, which movement, called "the drift," is compensated by having the slot in the rear sight for the drift slide, slope to the left. However, in some rifles the compensation is too great and in others it is not enough.

[Pg 487]

That reading of the wind gauge necessary to overcome the drift of a rifle at a particular range is called the "zero" of that rifle for that range, and all allowances for wind should be calculated from this reading.

The "zero" of a rifle is found by shooting it on a perfectly calm day.

1393. Estimating distance. Ability to estimate distances correctly is an important part of a soldier's education.

While it is true that fire on the battlefield will usually be by groups and the ranges will be given by officers, the battlefield is reached only after a long series of experiences in scouting, patrolling, and outpost duty, in which the soldier is frequently placed in positions where it is necessary that he shall determine for himself the range to be used in order that his fire may be effective.

There are different methods of estimating the range (for example, by sound, trial shots, range-finding instruments, etc.), but the only ones that the average soldier need know are those of estimating distance by the eye and by trial shots.

To estimate distance by the eye with accuracy, it is necessary to be familiar with the appearance, as to length, of a unit of measure which can be compared mentally with the distance which is to be estimated. The most convenient unit of length is 100 yards. To impress upon the soldier the extent of a stretch of 100 yards two posts 100 yards apart, with short stakes between to mark each 25 yards, should be placed near the barracks, or on the drill ground, and the soldier required to pace off the marked distance several times, counting his steps. He will thus learn how many of his steps make 100 yards and will become familiar with the appearance of the whole distance and of its fractional parts.

Next a distance of more than 100 yards will be shown him and he will be required to compare this distance with the 100-yard unit and to estimate it. Having made his estimate, he will be required to verify its accuracy by pacing the distance.

A few minutes each day should be spent in this practice, the soldier often being required to make his estimate by raising his rear-sight leaf and showing it to the instructor. After the first drills the soldier should be required to pace the distance only when the estimate is unusually inaccurate.

The soldier should be taught that, in judging the distance from the enemy, his estimate may be corrected by a careful observation of the clearness with which details of dress, the movements of limbs or of the files in a line may be seen. In order to derive the benefit of this method, the soldier will be required to observe closely all the details noted above in single men or squads of men posted at varying distances, which will be measured and announced.

Although the standing and kneeling silhouettes used in field practice afford good objects upon which to estimate distances, the instructor should make frequent use of living figures and natural objects, as this is the class of targets from which the soldier will be compelled to estimate his range in active service.

[Pg 488]

1394. Methods of estimating long distances by the eye. The following methods are found useful:

(a) The soldier may decide that the object cannot be more than a certain distance away nor less than a certain distance; his estimates must be kept within the closest possible limits and the mean of the two taken as the range.

(b) The soldier selects a point which he considers the middle point of the whole distance, estimates this half distance and doubles it, or he similarly divides the distance into a certain number of lengths which are familiar to him.

(c) The soldier estimates the distance along a parallel line, as a road on one side, having on it well-defined objects.

(d) The soldier takes the mean of several estimates made by different persons. This method is not applicable to instruction.

1395. Determination of distance by trial shots or volleys. If the ground is so dry or dusty that the fall of the bullets is visible to the naked eye or through a field glass, distance may be determined by using a number of trial shots or volleys.

In the case of individual trial shots, the soldier sets his sight at the estimated range, watching to see where the bullet strikes,—or some other man, with or without field glasses, may watch to see where it strikes. If the bullet strikes beyond the target, the estimated sight setting is decreased; if it falls short, the sight setting is increased.

In case of volleys, the sights are set at the estimated range and a volley is fired. If it appears to strike a little short of the mark, an increase in elevation of 100 yards is used for the next volley. When we have the target inclosed between two volleys, we take the mean of the estimated ranges for the correct range. For example, if the first estimated range were 1000 and the second 1100, the correct range would be 1050.

1396. Appearance of objects: How modified by varying conditions of light; difference of level, etc. During instruction the men should be taught the effect of varying conditions of light and terrain upon the apparent distance of an object.

Objects seem nearer—

- (a) When the object is in a bright light.
- (b) When the color of the object contrasts sharply with the color of the background.
- (c) When looking over water, snow, or a uniform surface like a wheat field.
- (d) When looking from a height downward.
- (e) In the clear atmosphere of high altitudes.

Objects seem more distant—

- (a) When looking over a depression in the ground.
- (b) When there is a poor light or a fog.
- (c) When only a small part of the object can be seen.
- (d) When looking from low ground upward toward higher ground.

1397. Effect of heat and cold. Heat causes shots to strike high, and cold causes them to strike low.

[Pg 489]

Therefore, if you shot on a warm day and made 5's, and recorded temperature and other conditions in your score-book, you would know on looking at your score sheets that you should raise your elevation, if you were firing on a cold day.

1398. Effect of moisture. Dampness causes shots to strike high and dryness causes them to strike low. Therefore, on damp days take lower elevations than on dry days.

1399. Effect of light. Light affects the aiming without the beginner knowing it. It does not, however, affect the travel of the bullet.

A dark target causes a tendency to aim farther below the bull's-eye than if the target were bright. Therefore, use higher elevations with dark targets. As it gets darker, higher elevations should be used.

If you *always aim carefully and correctly* the light will have little effect on your aiming,—that is, if your eyesight is good.

If you are shooting in a dull light and a bright sun comes out, say on your right, there is a tendency to move the front sight to the opposite (left) side of the rear sight notch, since the near (right) edge is shaded and obscured somewhat. Therefore $\frac{1}{4}$ to $\frac{1}{2}$ windage into the sun (right in this case) should be taken to overcome this.

In using battle sight, hold higher for a bright light.

We also raise our sights if a strong sun comes out. Therefore, we have this rule: *Move your rear sight into the sun, just as you do for a wind,—and raise your elevation.*

1400. Mirage gives a wavering appearance to the target. It is heated air that is moving. It is sometimes called "heat waves."

With the wind between 2 and 14 miles an hour on clear, hot days the waves can be seen moving across the target.

When there is no wind or a light six o'clock wind, the waves go straight up, or "boil." *Never fire when the mirage is boiling,—wait for it to move from one side to the other and then take windage to correct for it.*

1401. Summary of temperature, light and moisture effects:

Raise elevation for—	Lower elevation for—
Dull target	Bright target
Shooting in the sun	Target in sun
Hot gun	Cold gun
Dirty gun	Clean gun
Cold day	Hot day
Bright or shining sight	Moist day
Cloudy day	Full sights
12 o'clock wind	6 o'clock wind

1402. Firing with bayonet fixed. In firing with bayonet fixed usually a lower point on the target will be struck, corresponding to a reduction of about 50 yards in the range.

1403. Care of rifle. Since the accuracy of a soldier's rifle has a most important bearing on his shooting, and since the proper care of a rifle affects its accuracy, the care of the rifle is an important subject in which every soldier should be thoroughly instructed. The subject is fully covered in the preceding chapter. (Chapter XV, Part I).

[Pg 490]

COLLECTIVE INSTRUCTION

(Combat practice)

1404. General scheme. While individual instruction is most important, it is not everything. The maximum effect of fire in battle is obtained when a command, as a whole, is a pliable, manageable, effective instrument in the hands of a commander who can use it intelligently and efficiently. Therefore, the two objects to be obtained are:

1. To make the command a pliable, manageable, effective instrument in the hands of its commander.
2. To train and instruct the commander so that he will know how to use this instrument in an intelligent and efficient manner.

1405. To make the fire unit a pliable, manageable, efficient instrument. In order that a unit may be a pliable, manageable, efficient instrument in the hands of its commander, he must be able to control the unit absolutely,—that is to say, not only must the individuals composing the unit be so trained that they will respond at once, even in the din and confusion of battle, to the will of the commander, as expressed by his orders, but they must also be so instructed and disciplined that they can, as individual parts of the unit, perform their functions efficiently. This is accomplished by *fire discipline*.

1406. Fire discipline. By *fire discipline* is meant a habit of obedience, a control of the rifle, and a display of intelligence, all the result of training, which will enable the soldier in action to make hits instead of misses. It embraces taking advantage of the ground; care in setting the sight and delivery of fire, including proper fire distribution; constant attention to the orders of the leaders and careful observation of the enemy; an increase of fire when the target is favorable, and a cessation of fire when the enemy disappears; economy of ammunition.

1407. To train and instruct the commander to use the unit with intelligence and efficiency. In order to handle the unit with intelligence and efficiency, utilizing to the greatest extent possible the power of all the rifles under his command, not only must the commander be able to control the unit, having it respond at once to his every command, but he must also know tactics, and be thoroughly familiar with the technical principles of infantry fire.

1408. Combat exercises. A combat exercise consists of the application of tactical principles to certain assumed battle situation, in the execution of which are employed the appropriate formations and movements of close and extended order drill, and in which, as a rule, ball cartridges are used in firing at the targets.

By means of combat exercises, the unit commanders are trained and instructed in applying tactical principles, in controlling and directing the fire of their units and the men are trained and instructed in fire discipline.

The tactical principles applicable to combat exercises are covered in the Infantry Drill Regulations, under the headings of "*Fire*" and "*Combat*."

[Pg 491]

1409. Technical principles of firing. The technical principles of firing are given in detail in the Small-Arms Firing Manual, a summary of which is given below under the headings of, *The Effect of Fire*, *The Influence of the Ground*, and *The Adjustment of Fire*.

The Effect of Fire

1410. Ballistic qualities of the rifle. The accuracy of a rifle, the flatness of its trajectory, and its disabling power,—that is, the power it has to disable the enemy,—are called its *ballistic qualities*.

The accuracy of the U. S. Springfield rifle, caliber .30, model of 1903, is very high,—probably superior to that of any other military rifle.

The flatness of trajectory is dependent upon the muzzle velocity, and, to some extent, upon the form of the bullet. Our bullet is pointed and the muzzle velocity is 2700 feet per second, which is a very high muzzle velocity.

Two rifles of different type may be equally accurate, but the accuracy of the one having the flatter trajectory will, naturally, be less affected by slight errors in sight setting.

Again, another advantage of the rifle with the flatter trajectory is that it holds more ground under its fire. For example, take our service rifle: At a range of 500 yards, the bullet, at the highest point in its trajectory or line of flight, is 2 feet above the line of sight. It is, therefore, apparent that if the bottom of an object 2 feet or greater, is aimed at, it would be struck if it were anywhere under 500 yards. Now, take a rifle with a very curved trajectory, say one whose bullet, at the highest point of the trajectory corresponding to a range of 500 yards, is 10 feet above the line of sight. There will be a large extent of ground between the target and the rifle that is not danger space for a target 2 feet above the line of sight. Hence, we see that the rifle with the flatter trajectory is better.

The continuous danger space afforded by the flat trajectory of our service rifle enables us to adopt a universal sight for all ranges up to 500 yards,—that is, the battle sight, which is the rear sight ready for use when the sight leaf is laid down.

1411. Cone of fire or cone of dispersion. If a body of soldiers fire at the same target the bullets will not, of course, follow the same path, but will be scattered. This is due to differences in sights, parts of the rifle, ammunition, and to a greater extent, to the individual errors of the soldiers in aiming and firing.

The trajectories or paths of the bullets considered together form a horn-shaped figure or cone, called the *Cone of fire* or cone of dispersion. (See [Fig. 44.](#))

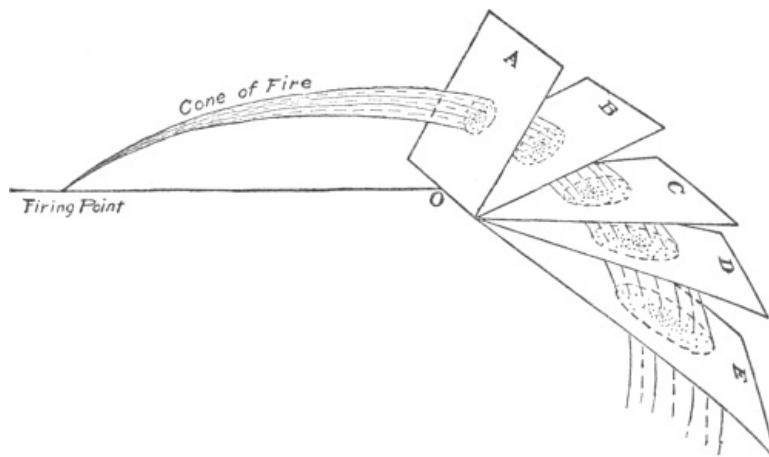

Fig. 44

1412. Shot group and center of impact. If the *cone of fire* be intercepted by a target (for example, A O, [Fig. 44](#)) at right angles to the axis of the cone, the shot holes will make a pattern or group called the *shot group*, the holes being the thickest approximately in the center of the group, called the *center of impact*. From this point in all directions the density of the grouping decreases progressively,—at first gradually, then more rapidly, out to the limits of the group.

Naturally, the size of the cone of fire and of the shot group vary with the skill of those firing, good shots making a small cone and small group, and poor shots a large cone and large group.

1413. Beaten zone. The intersection of the cone of dispersion with the surface of the ground is called the *beaten zone*.

If the surface of the ground is horizontal, the form of the *beaten zone* is that of an ellipse with its longer axis in the direction of the line of fire, as shown in [Fig. 45.](#)

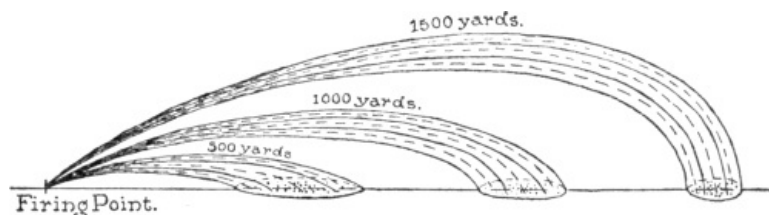

Fig. 45

In view of the fact that at the long ranges the angle of fall of the bullets is much greater than at short ranges, it follows that at short ranges the elliptical figure (beaten zone) is much more elongated than at long ranges. In other words, the longer the range, the shorter is the depth of

the beaten zone. This is shown in [Fig. 45](#).

1414. Uncertainty and ineffectiveness of long-range fire. It follows from what has been said, that as the range increases the length of the beaten zone decreases,—that is, a less depth of ground is held under fire. That being the case, if an error is made in sight setting due, for example, to an incorrect estimate of the range, the proportionate loss of fire effect due to misplacement of the center of impact will be greater as the beaten zone is less,—that is, as the range is greater.

Furthermore, the difficulty of exact range determination increases with the distance, the two influences combining to make long-range fire uncertain and usually ineffective.

1415. Zone of effective fire. That portion of the ground which contains the best 75 per cent of the shots in the beaten zone, is called the *zone of effective fire*.

Effectiveness of Fire

1416. Factors involved. The effectiveness of fire depends upon these three factors:

- (1) The percentage of hits made;
- (2) The number of targets hit;
- (3) The time of execution.

That is to say, the effectiveness of fire is determined by the number of enemies disabled or targets hit in a given time.

1417. Percentage of hits. By the percentage of hits is meant the proportion of all the bullets fired that hit the targets. For example, if 1000 bullets are fired and 750 hit the targets, then the percentage of hits is 75.

The percentage of hits depends upon the dispersion, and this is influenced by the precision of the arm, the range, the visibility of the target, the atmospheric conditions, the training and instruction of the troops, and upon their physical and moral state at the time. In addition, the percentage of hits also depends upon the character of the ground as favoring ricochet hits, upon the correct estimation of the range and the proper designation of the target.

1418. Number of targets hit. The number of targets hit,—that is, the distribution of fire,—may be affected by varying degrees of visibility, as men instinctively choose the more conspicuous marks as aiming points. Under any circumstances, a poor distribution of the hits made will be due to an absence of proper instructions from the leaders; or, in other words, to poor control, or else to a want of understanding or lack of obedience on the part of the men.

1419. Time of execution. The time of execution is important in that the gaining of fire superiority is dependent less upon obtaining high percentages of hits than upon making an absolutely large number of hits in a unit of time. There is necessarily a limit to the rapidity of fire which, if exceeded, will result in some loss of accuracy. With targets of a fair degree of visibility, the following may be taken as standard rates of fire for troops who have been given suitable training in target practice:

200 yards]	10 shots per minute.
300 yards		
400 yards		
500 yards]	7.5 shots per minute.
600 yards		
700 yards		
800 yards]	5 shots per minute.
900 yards		
1,000 yards		

Greater ranges, 3 shots per minute.

The rates given should not exclude higher rates of fire in the case of large and conspicuous targets. On the other hand, when objectives, or marks used as aiming points, are very indistinct, the requirement of correct aiming imposes rates of fire somewhat lower than the standard rates given even for well-instructed men.

With imperfectly trained men who have not fully acquired the habit of using aimed fire only, and who are lacking in the manual dexterity required for executing the standard rates of fire, the maximum rate can not well exceed six shots per minute without incurring the danger of lapsing into unaimed fire.

Fatigue and exhaustion, the results of marches or prolonged firing, have a detrimental influence and tend to lower the rates of effective fire.

1420. Defilade. If we will consider a bullet just grazing the top of an impenetrable obstacle (like "A," [Fig. 46](#)), the space from the top of such obstacle to where the bullet strikes the ground (space B E, [Fig. 46](#)) will be protected from fire. Such space is called, "*defiladed space*." Its extent will, of course, depend on the height of the obstacle, the curvature of the trajectory and the slope of the ground in rear of the obstacles.

[Pg 495]

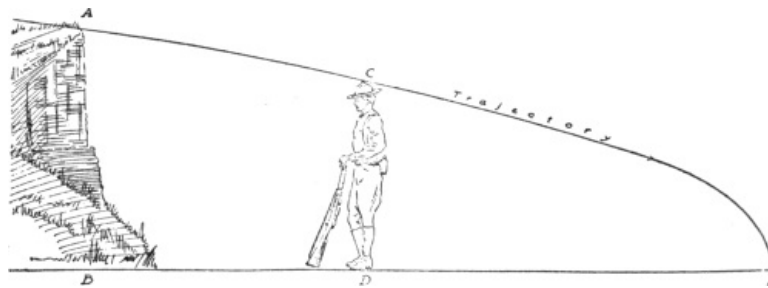

Fig. 46

Between B and D, a soldier standing would be completely protected; between D and E, he would be only partially protected. To obtain complete protection between D and E the soldier would have to assume the kneeling or prone position, depending on how far away from D he was.

By cover is meant effective defilade from the enemy's fire.

By concealment is meant screening from view but not necessarily protection from fire.

1421. Rising and falling ground. The influence of the ground upon the effect of fire is at once seen by studying [Fig. 44](#).

If the ground rises, as shown by B O and A O, the depth of the beaten zone (and consequently the effect of fire) decreases. On the other hand, if the ground falls (up to a certain point), the depth of the beaten zone (and consequently the effect of fire) increases.

1422. Depth of beaten zone affects only targets having depth. It should be remembered that depth of beaten zone can affect only targets which have depth.

On a target in the form of a line,—a line of skirmishers, for example,—the depth of the beaten zone has no effect one way or the other. If such a target, however, is backed up by supports and reserves, the depth of the beaten zone may have a decided effect on them, depending upon their distance in rear of the line forming the target and the slope of the ground in rear of such target.

In this connection, attention is invited to [Fig. 47](#), which shows how in the case of a fire delivered from a height at a target on a horizontal plane beneath, the beaten zone is shortened and consequently the fire effect decreased.

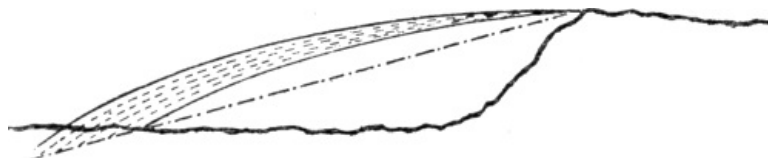

Fig. 47

An example of increasing the depth of beaten zone is seen in [Fig. 48](#), which shows a fire delivered from low ground at a target on the edge of a plateau or crest of a ridge from which the ground slopes to the rear.

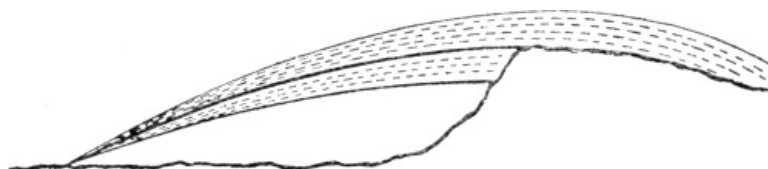

Fig. 48

1423. Grazing fire. Shots which pass over a crest with an angle of fall conforming, or nearly conforming, to the slope of the ground beyond the edge of the crest (as shown in [Fig. 48](#)), are called *grazing shots* and fire so delivered is called *grazing fire*.

[Pg 496]

1424. Diminution or increase in fire effect due to rising and falling ground. In connection with the diminution or increase in fire effect due to rising and falling ground, attention is invited to the following:

1. If the ground slopes upward to the rear from a firing line, the supports may be placed closer without increasing the danger from fire aimed at the firing line.

2. When the ground slopes down and to the rear from the firing line forming the target, the supports must be posted at a greater distance in rear, unless the slope is so much greater than the angle of fall of the hostile bullets that a defiladed space is created in which no bullets strike, in which case the supports may be brought up close to the crest.

3. On ground rising with respect to the line of sight, column targets (i. e., having depth) will suffer greater losses than lineal targets.

4. On ground falling with respect to the line of sight, the reverse slope of hills or the level grounds of plateaus, line targets will suffer the greater losses.

1425. Ricochet shots. When a bullet strikes any surface and is deflected it is called a *ricochet shot*.

Not only do bullets that ricochet usually tumble after striking, but they are also mutilated, so that wounds inflicted by ricochet hits are usually severe.

The most favorable ground for ricochets is a smooth, hard, horizontal surface, the aim being low, the chance of ricochets in sand is very slight.

1426. Occupation of ground. The question of the occupation of ground presents these two aspects:

1. What firing positions may be chosen which will tend to increase the losses of the enemy?
2. What positions may be chosen and formations adopted to minimize our own losses?

The selection of a defensive position presents this question: *Shall it be near the crest or well down the slope?*

A position well down the slope

Advantages:

1. The depth of the beaten zone for fire delivered from the position is increased and the upper portion of the cone of fire will include the supports and reserves advancing to reënforce the hostile firing line. That is to say, the fire will be a *grazing fire*.
2. It eliminates dead spaces that might otherwise exist at the bottom of the slope.
3. The hostile fire being directed against a point well down the slope, the high ground in rear will interpose as a defilade and intercept the upper portion of the cone of fire which might otherwise take effect on the supports and reserves behind the crest.

Disadvantages:

1. It makes withdrawal difficult in case it becomes necessary to fall back.
2. It is difficult to reënforce the firing line.

[Pg 497]

A position near the crest

Advantages:

1. It favors observation of the enemy.
2. It makes withdrawal easy in case it becomes necessary to fall back.
3. It is easy to reënforce the firing line by the supports advancing from behind the crest.

Disadvantages:

1. The depth of the beaten zone is decreased and consequently the cone of fire will probably not include the supports and reserves advancing to reënforce the hostile firing fire. In other words, the fire will be a *plunging fire*.
2. It is likely to result in dead spaces at the bottom of the slope.
3. It affords a good target for the hostile artillery.

Whether or not a position near the crest or a position down the slope should be chosen, depends, in each case, upon circumstances.

For instance in a rear guard action, where a determined stand is not contemplated, a position

near the crest would be occupied. On the other hand, if a determined stand were contemplated, the terrain offered good opportunity for the delivery of an effective grazing fire, and we had reason to believe that we were going to be subjected to heavy artillery fire, a position at the foot of the slope would be selected.

However, it may be said that, in general, a defensive position should be near the bottom of the slope.

1427. Gentle reverse slopes. From the point of view of avoiding losses, all gentle reverse slopes are dangerous and are to be avoided when possible.

When necessary to traverse or to occupy such ground, precautions must be taken to protect the reserves or other bodies of troops by placing them on the flanks; by disposing them in formations with a narrow front; by causing them to lie down; by the construction of suitable shelter, and by avoiding useless movements.

Adjustment of Fire

1428. Fire at stationary targets. The correct adjustment of fire is attained by causing the center of impact to fall on the center of the target. This is the problem constantly presented in combat firing.

The two important elements entering into this problem are, (1) the commander and (2) the troops. When a body of troops has aimed correctly at the target indicated, with the elevation ordered and has fired with steadiness, it has done all that can be expected of it, but that is not sufficient; for, if the commander, by giving the wrong sight-setting, for example, has failed to cause the center of impact to fall on the center, of the target, the result may be nothing. Hence the vital importance of knowing and announcing the correct range.

[Pg 498]

It is known that good shots make a small group and poor shots a large group, average shots making a group of intermediate size.

It is frequently stated that troops composed of good shots are not so effective in collective firing as poorer shots. How is this possible? The explanation is simple. The shot group of the good shots is small and if misplaced by an error in range estimation few hits result while the shot group of poorer shots, being larger, is not so much affected by the same error in range estimation, will cover the ground, and probably hit more figures. This, of course, is *only true* when a considerable error has been made in estimating the range.

As battle targets are mostly line targets, a displacement to the right or left does not amount to much, but an error in depth (range), as stated before, is serious. Thus we, see that the *correct determination of the range* is very important.

1429. Determination of range. The range may be determined, with only a small error, by a range finder. There are several other methods, as, for instance, by trial shots,—the dust thrown up by the bullet showing whether the range is too short or too great,—by sound, by the appearance of objects, etc., but except in deliberately prepared defensive positions, estimating by eye will be the most practicable method of estimating the range. For all practical purposes a very satisfactory result will be obtained by taking the average estimates of several trained men.

In observing the effect of the fire the ground may be wet, or covered with turf, sod or brush in which no signs of striking shots can be seen. By careful use of good field glasses some indication of the place where the shots are going, may be obtained. The actions of the enemy may often indicate whether the fire is effective or not.

1430. Combined sights. All other means failing, *combined sights* may be resorted to. By this is meant firing part of the troops with sights set at one range and part with a range greater or less by 100 yards or more. This increases the beaten zone and will generally assure a certain amount of fire effect. This method is seldom used under 500 yards.

1431. Auxiliary aiming points. It frequently happens that the target is so well concealed that it is invisible. In this case some well defined object in front or behind it must be used as an *aiming target*, and the range given so that the beaten zone will include the actual target at its center.

1432. Fire at moving targets. In firing at a moving enemy, a beaten zone must be established immediately in front, his forward movement into this zone completing the adjustment of fire. Due to the chance of overestimating the range, a sight-setting must be taken *well under* the estimated range (usually about 200 yards against advancing infantry).

When the fire becomes effective, as may be judged by the actions and movements of the enemy, the rate of fire should be quickened in order to increase the effect of the fire.

Frequent changes of sight not only cause a loss of time, but they also multiply chances of error in sight-setting. Changes in sight-setting against advancing infantry should not be less than 200 yards at a time, that is to say, when the enemy has passed through the zone of effective fire, the sight should be lowered 200 yards and the operation repeated until the battle-sight zone is

[Pg 499]

reached, when the rear-sight leaf is thrown down and no other sight manipulation is made.

Against skirmish lines advancing by rushes, the sight-setting should not be changed during a rush, but it should be done at the halts, so that the greater vulnerability of the targets presented during the rush may be taken advantage of.

Against retreating infantry, use the estimated range, and when the target appears to have passed beyond the zone of effective fire, add 200 yards to the sight-setting.

Against attacking cavalry, due to the rapidity of the advance, there will not usually be time for sight manipulation other than throwing down the rear-sight leaf, so that the battle should be resorted to at all ranges.

In firing at a target moving across the line of fire it is desirable, on account of the confusion caused thereby, to hit the head of the column. It is necessary, therefore, to hold to the front a distance sufficient to allow for the time of flight and the rate of march. This will be accomplished by the observance of the following rough rules:

1. Against infantry, hold against the head of the marching column;
2. Against cavalry at a trot, hold to the front 1 yard for every 100 yards of range; and at a gallop, 2 yards for every 100 yards of range.

1433. Night firing. In night firing it is almost impossible to adjust the fire by ordinary means.

In night attacks the purpose of the offensive is to gain rapidly and quietly a position where the issue may be decided in a hand to hand encounter, or a position from which the superiority of fire may be gained at daylight. For the offensive, therefore, fire action is a subordinate consideration.

On the defensive, when a night attack is apprehended, preparations should be made to sweep with fire the ground immediately in front over which the assailant must advance.

Special arrangements may sometimes be made for resting rifles on the parapet, so that the ground in front will be suitably covered. A solid support is necessary for maintaining the proper direction of the pieces during firing. For this purpose notched boards or timbers are convenient. The arrangements should be such that the operations of loading and firing may be performed without removing the rifles from the support.

Searchlight illumination may reveal the position and movements of the enemy sufficiently well to permit the use of the sights. In night operations of small parties fire may be well directed when a bright, well-defined light, such as a camp fire, is presented as an aiming point. In such a case a slight illumination of the front sight is required.

Fire Direction and Control

[Pg 500]

1434. General. As stated before in substance, the maximum effect of fire can be gotten only by instructed and disciplined troops under a commander capable of directing and controlling their fire properly.

The fire of a company may be likened to spraying water from a hose, and as the fireman can shift his stream of water from one point to the other with certainty, being able to direct and control it with promptness and accuracy, so should the company commander be able to switch the cone of fire of his company from one target to another, having it at all times under direction and control. In other words, as the pliable, manageable hose responds to the will of the fireman, so should the company be so trained and instructed that it will respond to the will of the company commander on the firing line, in the midst of the noise and confusion of battle. No one except a man who has been in battle can realize how great are the noise and confusion, and how necessary and important are coöperation, team-work, discipline, and communication, in order for a company commander to control and direct the fire of the company—there must be absolute coöperation, team-work, and communication between all parts of the company—between the captain and the platoon leaders, the platoon leaders and the squad leaders, and the squad leaders and the members of their squads. Each and every man must know and do his part and endeavor all he can to keep in touch with and help the others. Now, the foundation of team-work and coöperation, is communication—communication between the company commander and the men on the firing line—the means by which, the medium *through* which he will make known his will to the men on the firing line. As stated before, because of the noise and confusion on the firing line this is no easy matter. The ideal way would be for the company commander to control the company by communicating direct with every man on the firing line, as graphically shown on the following page:

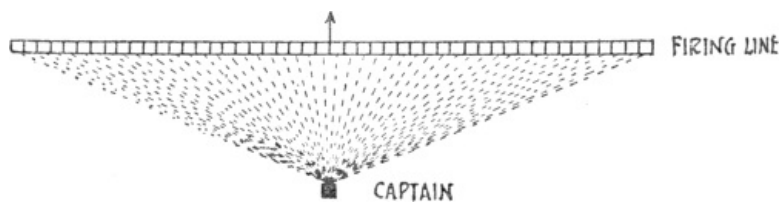

Fig. 49

However, in the noise and confusion of battle it would be utterly impossible for all the men to hear the captain's voice. Experience shows that from 20 to 35 rifles are as many as one leader can control. The captain, must, therefore, control the company through the platoon commanders—that is to say, he *actually directs* the fire and the platoon commanders, assisted by the squad leaders, *actually control* it. In other words, the captain communicates with the men on the firing line, he makes his will known to them, through his platoon commanders, as graphically shown in this diagram:

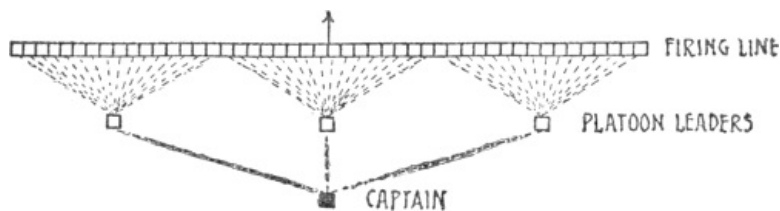

Fig. 50

[Pg 501]

However, in order for our system of communication to be successful, each and every man, as stated above, must know and do his part and endeavor all he can to help the others. If this is done, then the different parts and elements of the company will dove-tail and fit into one another, resulting in a complete, homogeneous whole, in the form of an efficient, pliable, manageable instrument in the hands of the company commander. And this is the object, the result, sought by practice and instruction in field firing, and which will be obtained if the captain, the platoon leaders, the squad leaders, the file closers, the musicians, and the privates, will perform the following duties and functions:

1435. The Captain. (*Fire direction.*)

The captain *directs* the fire of the company or of designated platoons. He designates the target, and, when practicable, allots a part of the target to each platoon. Before beginning the fire action he determines the range, announces the sight setting, and indicates the class of fire to be employed, and the time to open fire. Thereafter, he observes the fire effect, corrects material errors in sight setting, prevents exhaustion of the ammunition supply, and causes the distribution of such extra ammunition as may be received from the rear. (I. D. R. 249.)

Having indicated clearly what he desires the platoon leaders to do, the captain avoids interfering, except to correct serious errors or omissions. (I. D. R. 240.)

1436. The Platoon Leaders. (*Fire direction.*)

In combat the platoon is the *fire unit*. (I. D. R. 250.)

Each platoon leader puts into execution the commands or directions of the captain, having first taken such precautions to insure correct sight setting and clear description of the target or aiming point as the situation permits or requires; thereafter, he gives such additional commands or directions as are necessary to exact compliance with the captain's will. He corrects the sight setting when necessary. He designates an aiming point when the target cannot be seen with the naked eye.

In general, *platoon leaders* observe the target and the effect of their fire and are on the alert for the captain's commands or signals; they observe and regulate the rate of fire. (I. D. R. 252.)

1437. The Guides watch the firing line and check every breach of fire discipline.

1438. The Squad Leaders transmit commands and signals when necessary, observe the conduct of their squads and abate excitement, assist in enforcing fire discipline and participate in the firing.

Every squad leader should place himself just a little in advance of the rest of his squad and by occasionally glancing to the right and left, observe how the men of their squads are doing—whether they are firing at the proper objective, if the sights are apparently properly adjusted, if they are firing too rapidly, etc. After each shot the squad leader should look toward his platoon leader, and then glance to his right and left to observe his men, and then load and fire again.

[Pg 502]

1439. The Musicians assist the captain by observing the enemy, the target, and the fire effect, by transmitting commands or signals, and by watching for signals. (I. D. R. 235.)

1440. The Privates will take advantage of cover, exercise care in setting the sights and

delivering fire; be on the constant lookout for orders from their leaders; always aim deliberately; observe the enemy carefully, increasing the fire when the target is favorable and ceasing firing when the enemy disappears; not neglect a target because it is indistinct; not waste ammunition, but be economical with it; if firing without a leader to retain their presence of mind and direct an efficient fire upon the proper target.

1441. Distribution of Fire. The distribution of fire over the entire target is of the greatest importance; for, a section of the target not covered by fire represents a number of the enemy permitted to fire coolly and effectively. So, remember that all parts of the target are equally important, and care must be taken that the men do not neglect its less visible parts.

The captain allots a part of the target to each platoon, or each platoon leader takes as his target that part which corresponds to his position in the company. Every man is so instructed that he will fire on that part of the target which is directly opposite him.

If the target cannot be seen with the naked eye, platoon leaders select an object in front of or behind it, designate this as the aiming point, and direct a sight-setting which will carry the fire into the target. The men aim at the good aiming point or line, but with such an increased or decreased sight-setting, as the case may be, that the bullets will fall on the target instead of on the aiming point.

Distribution of fire is assured by dividing the whole target assigned the company into definite parts or sectors, and allotting these parts or sectors to the various platoons. And, of course, the whole of the target must be kept under fire while the company is advancing. This may be accomplished by one of two methods:

1442. Overlapping Method. In this method each sector (target) is covered by more than one fire unit. For example, in a company of four platoons the entire company sector would be divided in two parts, the right part being covered by the first and second platoons and the left part by the third and fourth platoons. When the first platoon ceases fire to advance, the second platoon would replace the lost rifles by firing faster. With three platoons the company sector would be divided into two parts, one being assigned to each flank platoon and the whole company sector to the center platoon. When the first platoon advanced, the center platoon would cover its target, both the center and third platoons increasing their rate of fire. With two platoons, each would cover the whole company sector.

[Pg 503]

1443. Switch Method. The company is divided into a number of parts, one less than the number of platoons in the company. One platoon is designated as the "switch," and swings into fire automatically into that sector from which the fire of its assigned unit is withdrawn. For example, with four platoons, and platoon rushes to start from the right, the company sector is divided into three parts assigned to the first, second and third platoons, the fourth being the "switch." When number 1 ceases fire to advance, No. 4 fires at No. 1's target; when No. 2 ceases to fire, No. 4 fires at No. 2's target, then at No. 3's target, and finally No. 4 advances.

1444. Individual instruction in fire distribution. Every man should be thoroughly drilled, instructed and trained always to *fire at that part of the hostile target which corresponds to the position he occupies in his platoon*. That is to say, if on the right of his platoon, he fires at the right (as he faces it) of the hostile target; if in the right center of his platoon, he fires at the right center (as he faces it) of the target, and so on. This is represented by the following diagram, the points A', B', C', etc., representing the parts of the hostile target at which the men occupying the positions A, B, C, etc., in their platoon, would fire:

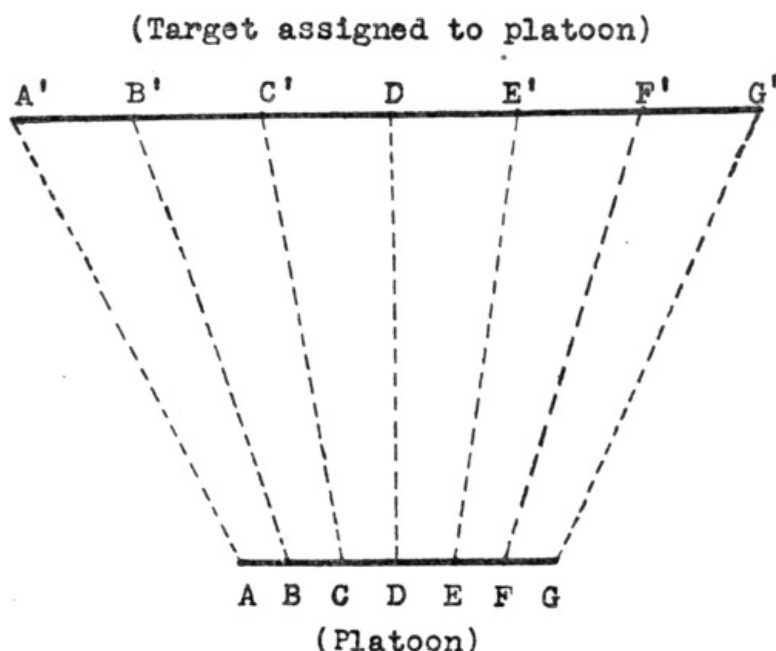

Fig. 51

1445. Designation of target. It is very important that the commanders should be able to describe the objectives to be attacked and the sectors^[19] to be defended, and that individual soldiers should be able to understand and transmit to other soldiers such descriptions. Within the squad, target designation implies ability on the part of the squad leader to understand and transmit to his squad the target designation received from his platoon leader, and also ability on his own part to designate a target intelligently; within the platoon, target designation implies ability on the part of the platoon leader to understand the company commander's designation of the target and to transmit that designation to his platoon in such manner as to insure an equal distribution of its fire within the sector assigned to it; within the company, target designation implies ability on the part of the company commander to designate the targets into which the company sector is divided in such manner that the platoon leaders will have no trouble in understanding him. It also implies ability on the part of the company commander to change the objectives or sectors of his platoons, and his ability to cover the whole target of the company during a forward movement of a part of the company, by the so-called "switch" or the "overlapping" method, or by any other method which is practicable and accomplishes the desired end. Targets should be designated in a concise, prompt, unmistakable manner, but, as we all know, it is not always an easy matter to describe the location of an object, especially if the object be not conspicuous or readily recognized. This is due to two reasons: First, the unit commander is likely to indulge in vague talk instead of accurate description, and, second, even if correct terms are used, it is more than likely that all members of the firing line will not be able to grasp the idea, because the commander will be using expressions which, although understood by himself (in some cases perhaps due to the fact that he is looking at the objective), they will not be clear to the men. The secret of prompt, accurate and concise designation of a target lies in the use of simple words and terms with which both the unit commander and the men on the firing line are thoroughly familiar.

Of course, if the target be distinct and clearly defined, it can easily be designated by name, as for example, "That battery on the hill just in front of us," "Cavalry to our right front," etc.

Generally the designation of a target, if not conspicuous nor readily recognized, will include:

1. A statement of what the target is, or its appearance (shape, color, size, etc.)
2. Where the target is with reference to some easily recognized reference point.
3. How wide the company sector is.

The following systems of target designation are used at the School of Musketry. Each has its limitations, defects and advantages, under various conditions of ground, etc. A wise selection of one or a combination of two or more, is a material factor in efficiency.

1446. Horizontal Clock Face System. (Used with visible, distinct targets.)

SYSTEM	EXAMPLE
1. Announce direction.	"At one o'clock."
2. Announce range.	"Range 1000."
3. Announce objective.	"A troop of cavalry dismounted."

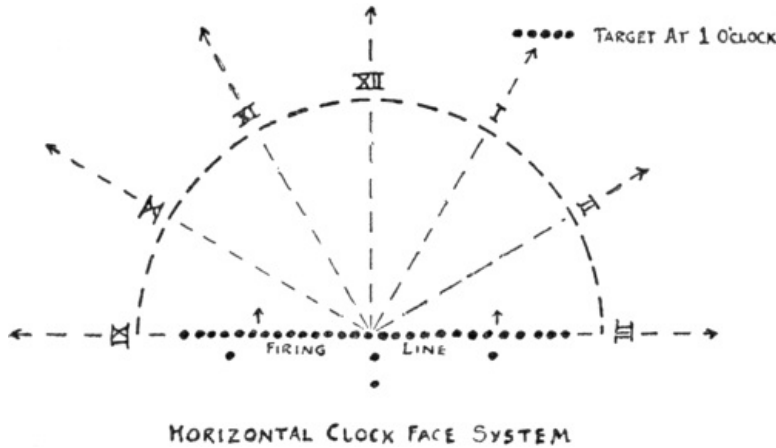

Fig. 52

PROCEDURE:

1. All look along the line pointing toward one o'clock of a horizontal clock face whose center is at the firing point, and whose 12 o'clock mark is directly perpendicular to the front of the firing line.
2. All look at a point about 1000 yards away on the one o'clock line, and
3. At 1000 yards on the one o'clock line find the objective.

1447. Vertical Clock Face System. (Used with small or indistinct targets.)

SYSTEM

1. Announce the general direction of the reference point.
2. Designate as a reference point the most prominent object in the zone indicated.
3. Announce the position of the target with respect to the reference point.
4. Announce the range.
5. Announce the objective.

EXAMPLE

"To our right front" (or "At two o'clock").
"A stone house with two chimneys."
"At three o'clock."
"Range 1000."
"A hostile patrol of four men."

[Pg 506]

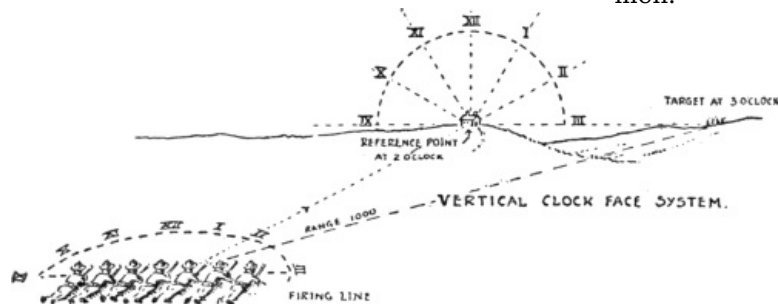

Fig. 53

PROCEDURE:

1. All men look to their right front (or along the two o'clock line).
2. The reference point (stone house) is found in the indicated direction.
3. A clock face (vertical) is imagined centered on the reference point, and the men look along the line leading from the clock center through three o'clock, and
4. 1000 yards from the firing point.
5. Find the hostile patrol.

1447a. Finger System. (Used with indistinct or invisible targets and to define sectors.)

(By one "Finger" we mean the amount of frontage that one finger, held vertically, will cover, the arm being extended horizontally to its full length. In the average case this amount of frontage covered is about $\frac{1}{20}$ of the range. For instance, at a range of 1000 yards, one "Finger" will cover fifty yards of the sector. The same result will be obtained by using the rear-sight leaf in the position of aiming.)

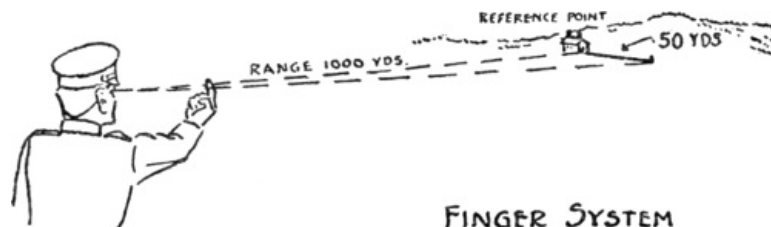

Fig. 54

SYSTEM

1. Announce direction to reference point as in the vertical clock face system.
2. Announce reference point.
3. Announce angular distance and direction from the reference point to the target.
4. Announce range.
5. Announce objective.

EXAMPLE

"To our right front, at 1000 yards."
"A stone house with two chimneys."
"Four o'clock, three fingers."
"Range 1000."
"A skirmish line alongside of the fence, length about two fingers, right at the dark bush."

[Pg 507]

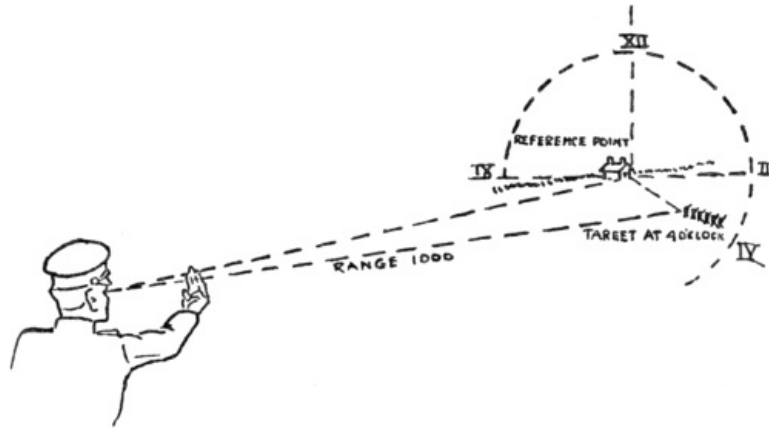

Fig. 55

PROCEDURE:

The reference point is found as explained, and the vertical o'clock line upon which the target will be found. The soldiers who do not see the target will extend the aim to its *full extent* palm of the hand upward, finger held vertically with one side of the hand "against" the reference point. The target will be found on the four o'clock line, and touching the third finger, at 1000 yards distance, its right flank at the bush and its left flank about 100 yards farther to the right.

The following case will illustrate more concretely the use of the "Finger" system:

There is a red house about $\frac{3}{4}$ mile to our front, and to the right of this house and a hundred yards or so to its rear, there is a line of trenches that can be seen with the aid of field glasses, but the trenches are difficult to locate with the unaided eye. There is no prominent landmark in the direction of this line of trenches, or on either flank, except the red house mentioned. The company commander locates the flanks of the line of trenches through his field glasses; he then extends his arm forward horizontally its full length, palm up, raises the fingers of his hand and, sighting on the line of trenches, finds that the trench line has a length of four "finger widths," and that the flank of the line nearest the red house is three "finger widths" from it. He decides to divide the line into two sections of two "fingers" each, and assign one section to each of his two platoons. He then calls his platoon leaders (and range finders, if necessary), and says, for instance: "Center of objective, five to the right of that red house, First Platoon, two fingers; Second Platoon, two fingers." The two platoon leaders then estimate the range and give the company commander their estimates independently. The company commander also estimates the range, and taking the average, then announces the range, say 1300 yards, after which the platoon leaders return to their platoons, and give, for instance, these instructions: "The target is a line of trenches four 'fingers' long, and about 1300 yards away; the center of the target is five 'fingers' to the right of that red house, at about 10 o'clock. We are to fire at the two fingers on the right of the center and the Second Platoon will look after the two fingers on the left of the center." (The leader of the Second Platoon gives similar instructions.)

[Pg 508]

Every man in the platoon figures out the platoon objective and endeavors to fix it with respect to some features of the ground so that he will be able to pick it up promptly after his platoon starts to advance. After fixing well in his mind the platoon objective, he figures out what part of it belongs to his squad, and then selects that portion of the squad objective corresponding to his position in the squad. If during the advance, his particular portion of the target should become hidden from view, he will fire on the nearest portion of the trench line, returning to his own part as soon as it becomes visible.

1447b. Communication. After the company has been committed to the fire fight, verbal commands cannot be heard, and it is well nigh impossible even to secure attention to signals. It is, therefore, most important that we should train and practice the company as much as possible during time of peace in the rapid and accurate transmission of orders and signals along the firing line.

Matter upon which a commander would need to communicate with his subordinates, in addition to tactical orders, would generally be confined to:

- (a) Changes of elevation and deflection.
- (b) Changes in the apportionment of the target among the subdivisions.
- (c) Changes within the limits of the sector, or objective.
- (d) Changes in the rate of fire.
- (e) And rarely change of target from one within to one without the limits of the objective or sector.

1448. Procedure. The following is given merely as a concrete example of the procedure that might be followed in certain ring exercises—it will not, of course, apply to all cases; it is merely

given as a concrete illustration of what might actually be done under certain conditions.

Company Commander. On receiving his instructions from the officer in charge of the exercise, the company commander returns to his company, keeping track of the changing aspect of his target as he does so. Arriving at the center of his company, he is met by his platoon leaders, and range finders, who have assembled in his absence. The company commander says:

"The target is a line of skirmishers, visible in part. It may be seen between us and that long line of green bushes which begins one finger to the right of that red water tower at 11 o'clock and it extends well beyond the bushes both to the right and to the left."

[Pg 509]

(At this point the range finders begin their estimation and the captain pauses until the senior range finder, or other designated person automatically announces the average estimate of the range, saying for example, "range 1100.")

The captain then resumes, saying:

"The sector assigned to this company is three fingers long and extends from that group one finger to the right of the water tower, to a point four fingers to the right of the tower. Each platoon will cover the entire company sector. Range ten-fifty and eleven-fifty. Fire at will at my signal. Posts."

Platoon Leaders. The platoon leaders then hasten to the center of their platoons and "put into execution the commands and directions of the captain, having first taken such precautions to insure a correct sight-setting and clear description of the aiming point as the situation permits or requires" (Par. 251 I. D. R.), by saying:

Target: The target is a line of skirmishers about 1100 yards to our front, only parts of which are visible.

Reference point: That long line of bushes about 1300 yards to our left front. The company sector is three fingers long and lies between us and that reference point, extending one-half finger beyond each end of the bushes.

Aiming point: The bottom of the line of bushes.

Range: 1050 and 1150.

As soon as the range is announced each front rank man sets his sight at 1050 and each rear rank man at 1150. Squad leaders assure themselves that sights are set and that the men of their squads understand the aiming point and sector and then raise their hand as a signal that all are ready. Similarly, the platoon leaders raise their hands to show that all of the squads are ready, and when the captain sees that all of his platoons are ready, he signals to begin firing. At the captain's signal, each platoon leader commands: "*Fire at Will.*"

Firing then begins at a rate of about 3 shots per minute (Par. 14, I. D. R.).

1449. Points To Be Borne in Mind. Bear in mind the following points in the solution of field firing problems:

1. Combine sights should, as a rule, be used where the estimated range is 1000 yards or more, the two ranges being 50 yards on each side of the estimated range, the even numbers firing at one range, the odd numbers at the other.

2. When aiming points are chosen they should be clearly described. Bushes, bunches of lines of grass, fence posts, etc., should not be designated as aiming points when clear and more definite aiming points are available. The choice of the best of several possible aiming points is of great importance.

3. Have some system of simple signals whereby you may know when all your men are ready to begin firing. Otherwise, you may begin the firing before some of your men have their sights set and before they understand the sector and point of aim. For example, let each squad leader raise his right hand when his squad is ready, and each platoon leader his right hand when his platoon is ready.

[Pg 510]

4. Platoon leaders must always be sure to designate a definite aiming point. Remember that in the case of an indistinct target, the company commander describes the TARGET to the platoon leaders, and they in turn announce the AIMING POINT. Having seen and located the target, the platoon leader must examine the terrain at, in front of and behind the target, and choose the aiming point for his men. He must then determine the proper sight-setting for that particular aiming point. He then announces both aiming point and range.

5. Instead of describing a sector as, for example, extending so many yards (or so many "fingers") north from the reference point, it is better to describe it as extending from the reference point northward for a definite distance, as "To that tall red house."

The last method is the best, because it leaves no room for guessing on the part of subordinates. So, remember it is always best, when possible, to define the limits of sectors physically, as,

extending, for example, from "That house to that windmill," etc.

6. When acting as part of the battalion, always be sure to designate someone (usually one of the musicians) to watch for signals from the battalion commander, and don't fail to repeat back all signals.

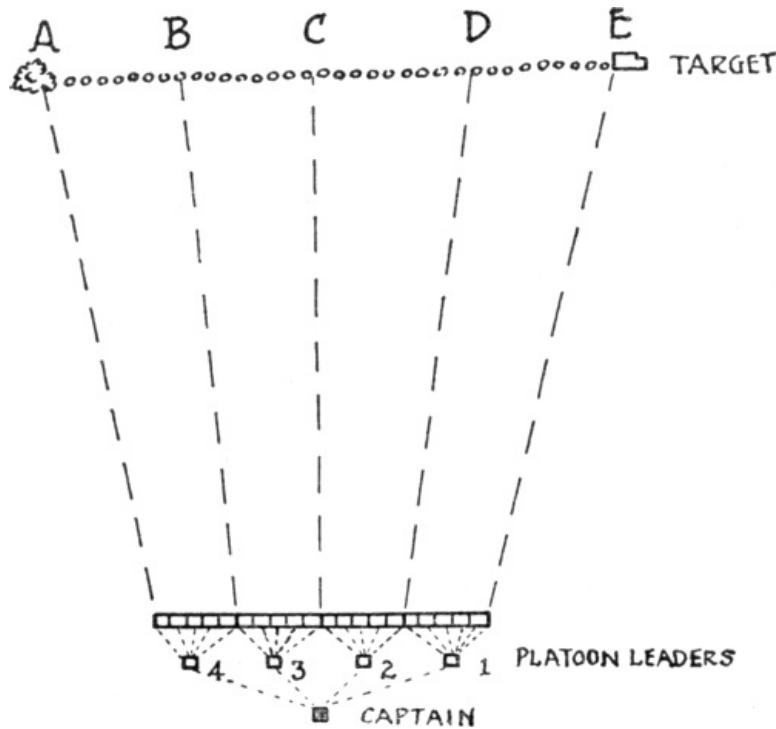

Fig. 56

7. In advancing by rushes, always allow sufficient time between rushes to recover the loss in fire caused by the cessation of fire. In other words, the next rear unit should not start forward until the one that has just advanced has resumed an effective fire.

[Pg 511]

8. Remember that in all field firing problems the distribution of hits has big weight. Consequently, it should be definitely understood beforehand, that, in the absence of any target designation by the company commander, each platoon leader will look after the sector corresponding to his front, and that each man will fire at the part of the sector corresponding to his front. Should the targets in a given sector disappear, then the platoon leader covering that sector will at once switch his fire to the adjoining sector until the reappearance of the targets in his own sector. For example, let us suppose the company sector, A-B (the company being on the defense and not advancing) is divided into four parts A-B, B-C, C-D and D-E. Platoon No. 1 would look after everything that appeared in D-E; No. 2, after everything that appeared in C-D; No. 3, everything that appeared in B-C; and No. 4, after everything that appeared in A-B.

Should the target suddenly disappear from D-E, then No. 1 would switch his fire over to C-D, and keep it there until the target reappeared in D-E, and if the targets disappeared from C-D, before reappearing in D-E, then both No. 1, and No. 2, would switch their fire cones to A-C.

1450. Exercises. The following exercises for the elementary training of individuals and squads were used with success by the troops mobilized on the Texas border:

TARGETS

1. The target will be represented by individual soldiers.
2. With reference to their visibility, the battlefield will present three classes of targets:
 - (a) Those which are visible throughout.
 - (b) Those which are visible in part.
 - (c) Those which are invisible, but whose location might be described.

Targets will be arranged to simulate one of the classes enumerated. Instruction will begin with simple exercises in which the target presented is plainly visible, and represents only the objective of the unit undergoing instruction. It should progress to the more difficult exercises in which the target is invisible and the line of figures is prolonged to include the objective of units on the right or left.

3. The limits of indistinct targets may be shown to unit commanders by the use of company flags. These flags, however, will be withdrawn from sight before a description of the target or estimate of the range is attempted, and before anyone but the commander of the unit undergoing instruction sees their location.

4. At the conclusion of each exercise in which flags are used to mark the limits of the target or its subdivisions, they should be displayed, in order that any existing errors may be readily pointed out.

5. To determine proficiency in target designation, the instructor will provide a sufficient number of rifles, placed on sand bags or other suitable rests, and require those charged with fire direction and control to sight them at the limits of their objective. An inspection by the instructor will at once detect errors. Similarly, in those exercises in which all the members of the firing unit participate, the percentage of rifles aimed at the correct target may be determined.

[Pg 512]

6. In these exercises no method of communication will be permitted that could not be used under the conditions assumed in the problem.

EXERCISE NO. 1—RANGING

Object: To train the individual to set his sight quickly and accurately for the announced range and windage; and to accustom leaders to the giving of windage data.

Situation: The company is formed in single rank at the ready with rear sight set at zero and the slide screw normally tight.

Action: The range and windage are announced, sights are set accurately in accordance therewith and as rapidly as may be, each man coming to port arms immediately upon completing the operation.

Time: Time is taken from the last word of the command.

Standard: Sights should be correctly set within 15 seconds.

Note: Of the two elements, time and accuracy, accuracy is the more important.

Par. 411, I. D. R., implies complete use of the rear sight, that is, utilization of the wind gauge, and sight setting to the least reading of the rear sight leaf, i. e., 25 yards. Sight setting therefore in this exercise should include, more often than not, "fractional ranges" and windage data.

EXERCISE NO. 2—RANGING

Object: To familiarize officers and noncommissioned officers in the use of an auxiliary aiming point.

Situation: Two men with the company flags are stationed to mark the enemy's invisible position. This position should be suitably located with reference to a practicable aiming point.

Action: The markers are signaled to display their flags. An officer or noncommissioned officer is called up and the enemy's position is pointed out. The flags are then withdrawn and the officer or noncommissioned officer selects an auxiliary aiming point and gives his commands for firing at that point.

EXERCISE NO. 3—TARGET DESIGNATION

Object: To train the individual soldier to locate a target, from a description solely. To do so quickly and accurately and fire thereon with effect, and to train officers and noncommissioned officers in concise, accurate and clear description of targets.

Situation: The men are so placed as not to be able to see to the target. The instructor places himself so as to see the objective.

Action: The instructor, to one man at a time, describes the objective, and directs him to fire one simulated round. The man immediately moves so as to see the target, locates it, estimates the range and fires one simulated shot.

Standard: For ranges within battle sight, time 20 seconds; beyond battle sight, time 30 seconds. Not more than 15% error in the estimation of the range. Objective correctly located.

[Pg 513]

Note: Arrangements made so that the description of the target is heard by only the man about to fire. After firing the man will not mingle with those waiting to fire.

EXERCISE NO. 4—TARGET DESIGNATION

Object: To train the squad leader in promptly bringing the fire of his squad to bear effectively upon the target presented. To train the individuals of a squad to fire effectively from orders of the squad leader and automatically to obtain effective dispersion.

Situation: The squad is deployed, the squad leader being in the firing line. Position prone. A sighting rest is provided for each rifle.

Action: Upon the appearance of the target the squad leader gives the necessary orders for delivering an effective fire. The men under these orders sight their rifles and then rise. The instructor then examines the position and sighting of each rifle.

Time: Time is taken from the appearance of the target until the last man has risen.

Target: A squad of men to outline a partially concealed enemy emerges from cover, advances a short distance and lies down.

Standard: 90% of the rifles should be sighted in conformity with the orders of the squad leader and should evenly cover the whole front of the objective. The squad leader's estimate of the range should not be in error over 15%.

Note: The squad leader should not, in general, be allowed to divide the target into sectors but to obtain distribution by training the men to fire at that portion of the objective directly related to the position they occupy in their own line. The exercise should be repeated with the squad leader in rear of the squad and not firing. As to this, it is to be noted that Musketry School experiments prove that in small groups the directed fire of say seven (7) rifles is more effective than the partially undirected fire of eight rifles obtained when the group leader is himself firing.

EXERCISE NO. 5—COMMUNICATION

Object: To teach prompt and accurate transmission of firing data without cessation of fire, and also to teach automatic readjustment of fire distribution.

Situation: A squad deployed in the prone position and with sighting rests, is firing at a designated target.

Action: A squad with sights set at zero is deployed and brought up at the double time into the intervals of the firing line and halted. The firing data is transmitted to them without cessation of fire. At the command **Rise**, given 20 seconds after the command **Halt**, the first squad rises and retires a short distance to the rear. At the same time, the supports cease fire and adjust their rifles in the rests so as to be aimed at the target as they understand it. They then rise and their rifles are examined by the instructor for range and direction.

[Pg 514]

Standard: 80% of the rifles should be sighted according to the transmitted data and aimed according to the principles of fire distribution.

Target: One target equal to a squad front, which is increased to two squads prior to the arrival of the supports in the firing line.

Note: This exercise should be repeated with the supporting squad reënforcing on a flank. To determine whether the original squad is able to keep its assigned sector during an advance, this exercise should be repeated, the supports being thrown in after a series of short advances by the original squad. Care should be exercised to prevent the transmission of firing data in a manner under which service conditions would be impracticable. (See Exercise No. 6.)

EXERCISE NO. 6—COMMUNICATION

Object: To train the squad leader in receiving and transmitting instructions by visual signals alone.

Situation: A squad with its leader in the firing line is deployed in the prone position firing at will.

Action: The instructor, without sound or other cautionary means, signals (visually) to the squad leader at various intervals to,

- First: Change elevation.
- Swing the fire to the right or left.
- Suspend the firing.
- Etc., etc.

The squad leader, upon receiving a signal, causes his squad to execute it without verbal command, or exposing himself.

Time: No specified time limit.

Standard: The squad leader should fire with his squad, but after each shot should look towards his platoon leader for any signal, then observe the fire and conduct of his men, then, after glancing again at his platoon leader, fire again. This the squad leader should do without exposing himself. By lying about a head's length ahead of his men he can see his squad front. In transmitting orders he can accomplish it by nudging the men on his right and left and signaling to them with his hand.

Note: This exercise is essential to prepare men for the deafening noise of a heavy action when speech or sound signals are largely futile.

EXERCISE NO. 7—FIRE DISCIPLINE

Object: To train men to carry out strictly the fire orders given them, and to refrain from starting, repeating or accepting any change therefrom without direct orders from a superior.

Situation: A squad deployed in the prone position.

[Pg 515]

Action: While the squad is firing at an indistinct but specified target, another and clearly visible target appears in the vicinity of the first target but not in the same sector. Upon the appearance of this second target, the instructor sees that the men continue firing at the assigned target. The corporal should check any breach of fire discipline.

Note: Variations of this exercise should be given to test the fire discipline of the men in other phases, such as rate of fire (Par. 147, I. D. R.), etc.

FOOTNOTES:

[18] The subjects of fire control and fire direction are covered in [pars. 285-290](#); [1434-1436](#).

[19] In attack the target is called "objective"; in the defense, "sector."

PART V

[Pg 516]

CARE OF HEALTH AND KINDRED SUBJECTS

CHAPTER I

[Pg 517]

CARE OF THE HEALTH

1451. Importance of good health. Good health is just as necessary to an army as rifles and ammunition. Not only does every sick man take away one rifle from the firing line, but in addition he becomes a care and a burden on the hands of the army. Indeed, it is fully as important for a soldier to take care of his health as it is for him to take care of his rifle and ammunition. The importance of doing everything possible to look after one's health is shown by the fact that in every war so far, many more men have died from disease than were killed in battle or died from wounds. In our Civil War, for instance, for every man on the Union side who was killed in battle or died from wounds, two died from disease. In the Spanish American War the proportion was 1 to 5¹/₂.

To do all that he can to keep in good health is a duty that the soldier owes his country.

1452. Germs. Diseases are caused by little, tiny live animals or plants called *germs*. They are so small that you require a magnifying glass to see them.

The following illustrations show the typhoid and malarial germs as seen through a magnifying glass:

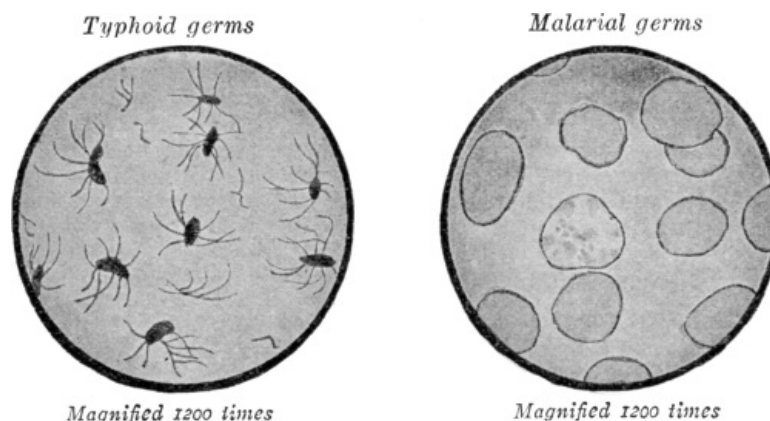

Fig. 1

The Different Ways of Catching Disease

1453. Five ways of catching disease. There are only five ways to catch disease:

1. By breathing in the live germs.
2. By swallowing the live germs.
3. By touching the live germs.
4. By having the live germs stuck into the skin by insects that bite.
5. By inheritance from parents.

Diseases Caught by Breathing in the Germs

1454. The more common diseases. The following are some of the more common diseases caught by breathing in the germs: Colds, diphtheria, tonsillitis, grippe, scarlet fever, pneumonia, and consumption.

The germs that cause these diseases grow well in the dark, warm, moist lining of the nose, throat, windpipe and lungs, and they are coughed or sneezed out or blown out and float in tiny bubbles in the air or fall to dry into dust which is blown about with the wind, and so are breathed in, or they may be transferred directly by kissing invalids and sick children.

1455. How to avoid breathing in sickness. Do not visit sick people or a house where the children are sick.



Fig. 2
Distributing sickness

Do not let other people cough or sneeze over your food or in your face.

Do not allow others to spit on the floor of your squadron or tent.

Do not do these things yourself.

Blow your nose into a handkerchief that can be boiled or into a piece of paper that can be burned.

Put your hand before your face when you cough or sneeze.

Rinse out the nose with hot, weak salt water at night and especially if you have been inhaling dust.

Brush the teeth after each meal and before going to bed.

Do not pick the nose with the finger nails; it makes sore spots in which germs grow.

On dusty hikes tie a handkerchief across the nose and mouth.

Never sweep the floor with a dry broom. Use a damp mop and so pick the germs up and carry them out instead of driving them up in the air as dust.

Diseases Caught by Swallowing the Germs

1456. The more common diseases. The following are some of the more common diseases caught by swallowing the germs: Typhoid fever, dysentery, cholera, and ptomaine poisoning.

1457. Water as a distributor of disease. Impure water is one of the most common distributors of disease that there is. Therefore, water from sources unknown or soiled by sewage, should be avoided as deadly and should not be used, *unless boiled*, for drinking, brushing the teeth or rinsing mess kits.

You can not always tell polluted water by its appearance, smell or taste. Unless from a sewer or drain, it may look clear and sparkling, with no smell and have a pleasant taste, so, water that is not known to be pure should not be drunk.

1458. Vegetables as a distributor of disease. In some localities the inhabitants use the streams for all purposes; drinking, washing clothes, bathing, washing vegetables and table utensils and as a sewer. When kitchen gardens are irrigated with such water the germs are to be found on the cabbages, beets, etc.

1459. Food, fruit, cigarettes, and drinking cups as distributors of disease. Germs may be smeared on the hands and thus transferred to articles of food, fruit, cigarettes, or drinking cups, especially in public places, so that he who buys at the public stands may have disease handed to him with his purchase.

1460. The fly as a disease carrier. The ordinary fly is one of the worst and filthiest transmitters of disease in existence.

Flies carry germs from privies, latrines, spittoons, and sick rooms to the food on your table, by means of their smeared feet, in their spit or in their specks.

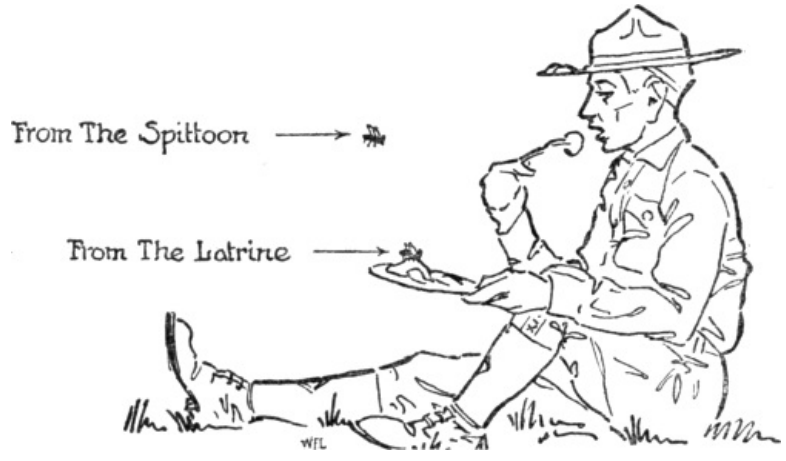

Fig. 3

1461. The dog as a distributor of disease. Dogs are often distributors of disease. They use their tongues for toilet paper and afterwards lick their coat or the hands of their friends. Petting dogs or letting them lick your hand is dangerous.



Fig. 4
'Nice doggie'
(And "nice doggie"
may be giving him
some disease)



Fig. 5
Boiling water to kill germs

1462. How to avoid swallowing disease. Do not drink water that is not known to be safe. If you have no one to ask and are traveling, it is safer to drink tea or coffee, because they have been made from boiled water, or to drink bottled mineral waters. In the field boil your drinking water. Boiled germs are dead and will not grow. They are, therefore, harmless.

[Pg 520]



Fig. 6
Next!
(What germs will he leave
on the cup?)

Beware of water from wells, farm pumps ponds, cisterns, water coolers and barrels, especially in railroad cars, stations, and ferry boats.

Do not drink lemonade, soft drinks, or milk from peddlers.

Beware of the public drinking cup.

Always wash your hands before going to meals and before putting things into your mouth, especially after going to the toilet or handling animals.

Do not adopt strange dogs and do not pet dogs.

Before eating fruit or raw vegetables, wash and peel them unless picked from the tree by yourself.

Do not eat food that is spoiled, smells or tastes badly or is flyblown or



Fig. 7
Swallowing sickness

maggoty or full of bugs.

Do not eat food which is not sufficiently cooked. All smoked, dried or salt meats or fish, such as ham, bacon, sausage, dried beef, bloaters, salt mackerel or codfish, must be well cooked, as they may contain "Measles" or other worm eggs. Cooking kills the egg.

Do not eat food exposed on public stands to dust, flies, dirty hands, dirty water, dirty cans, or dirty glasses and buckets.

Do not allow flies to breed in dirt or other filth around the house, nor allow them to walk on your food. This is possible by burning, burying or otherwise removing the dirt or filth, and by using fly traps, "swatters" and fly paper.

Do not wet lead pencils with your spit.

Do not wet your fingers with spit when you deal cards or turn over pages of books or magazines.

Keep the teeth brushed and the mouth clean. Have decayed teeth repaired at once. Decayed teeth drop out and they cause abscesses, which may destroy the jaw bone or cause brain fever. Old snags give the stomach the germs of rotting, which cause dyspepsia.

Diseases Caught by Touching the Germs

1463. The more common diseases. The following are some of the more common diseases caught by touching the germs: Ringworm, mange, barber's itch, sore eyes, boils, carbuncles, lockjaw, small pox, chancroid, syphilis, and gonorrhoea (clap). [Pg 521]

1464. Ringworm, mange, and barber's itch. These diseases are carried from person to person by finger nails and hands and from dirty water to those who bathe in it or have their underwear washed in it.

1465. Lockjaw. The germs of lockjaw are found in manure and in soil fertilized with it; hence, a bullet which passes through such soil before wounding carries these germs into the wound. Any wound soiled with such dirt will be infected. Also, wounds made by toy pistols and fire-crackers often contain lockjaw germs.

1466. Chancroid, syphilis, and gonorrhoea (clap). These are diseases whose germs are usually caught from prostitutes and whores, or from husbands who have caught the germs from prostitutes and whores. They are called "Venereal diseases," after Venus, the Roman goddess of lustful love, but they are very often caught in other ways than in sexual intercourse, and by innocent persons.

The chancroid plant causes a very nasty sore, the *chancroid*, which often destroys much flesh and causes buboes. The germ can be carried on the fingers to any part of the body. When the chancroid is healed and the bubo becomes a scar the disease is cured.

The *syphilis* germ will grow first where it is rubbed in, causing a hard ulcer, called a chancre, and after that it travels through the entire body. No place is sacred to its destructive power and it lives as long as the patient does. It is the cause of much insanity, palsy, apoplexy, deafness, blindness and early death. In mothers it causes miscarriages and in children it causes stillbirths, freaks, deformities, feeble minds and idiots; also, deaf and dumb, palsied, stunted, sickly and criminal conditions.

A syphilitic person is always dangerous although apparently well. He often has a sore mouth and his spit is as dangerous as that of a mad dog. The bite of such a man will develop a chancre and any pipe, cup, or tooth pick which he uses, or his kiss, will give syphilis. A syphilitic tattooer who wets his needles and his India ink with spit will put a chancre into the skin with the picture.

The instruments of cheap advertising dentists and of quack doctors or ignorant nurses can carry these germs from one person to another. So can the razors and caustic stick of barbers who are careless.

The clap plant likes to grow in the linings of the openings of the body where it is dark and warm and moist where it causes a catarrhal discharge called *clap*, which is easily smeared on hands, towels, handkerchiefs or by actual contact.

It grows well in the eyelids, causing great damage and often blindness. Many babies get the clap plant into the eyes during birth, from the mother, and unless treated within a few minutes after birth, have sore eyes and go blind,—a terrible calamity to the child and the family. If you have clap the germs can be carried on your hands to your eyes.

The clap plant also grows well in the cavities of the joints, causing rheumatism and crippling; it grows in the heart, causing valvular heart disease, which is incurable, and also in the generative organs of men and women, causing self-made eunuchs and childless wives. It is the cause of most [Pg 522]

of the severe abdominal diseases of women requiring the use of the knife to cut out the diseased part.

The venereal diseases cause more misery than any others and most of the doctors would have to go into other professions to earn their living if these diseases did not exist.

When a young man is "sowing his wild oats" he is really planting in his own body the syphilis and clap plants, and the harvest will be greater than any other crop. He will reap it in days of bedridden misery, and possible sudden death. He will reap it in bitter hours by the bedside through the illness and death of his wife or in her long years of ill health. He will reap it in little white coffins, idiot babies; blind, deaf and dumb, sickly and stunted children. And it will cost him lost wages and hospital and doctor fees.

Yes, the wild oats crop is a bumper crop. King Solomon was wise when he warned his son against the harlot, "for her end is bitter."

The best way to avoid venereal diseases is to keep away from lewd women, and live a clean moral life. It is said by medical authorities that sexual intercourse is not necessary to preserve health and manly vigor, and that the natural sexual impulse can be kept under control by avoiding associations, conversations, and thoughts of a lewd character. However, persons who will not exercise self-control in this matter can greatly lessen the risks of indulgence by the prompt use, immediately upon return to camp or garrison, of the prophylaxis prescribed by War Department orders and which all soldiers are required to take after exposing themselves to the danger of venereal infection. Men who immediately after intercourse urinate and wash the private parts thoroughly with soap and water will lessen the chances of infection. Drunkenness greatly increases the risk of infection.

Should one be so unfortunate as to contract venereal disease, he should see a first-class, reputable physician AT ONCE, the sooner the better. It is a fatal mistake to try to conceal venereal disease by not seeing a doctor, he who does so is taking a most dangerous chance of ruining himself physically for life.

1467. How to avoid diseases caught by touching the germs. Keep your skin clean with soap and water.

Do not bathe or wash your clothes in dirty water, have them boiled when laundered.

Do not go barefoot, even in barracks.

Do not use towels or toilet articles of other people, especially in public wash-rooms unless they furnish a fresh towel for you. Do not sleep in houses left empty by the enemy unless ordered to do so.

Do not sleep in native shacks in the tropics.

Do not rub the eyes with dirty hands. When dirt gets in have a doctor get it out.

If you have clap, do not rub your eyes with your hands, and wash your hands well with soap and water after taking treatment or passing water.

Do not handle dogs or cats, especially strange or sickly ones.

Do not clean the ears with sticks or straws,—have a doctor do it for you.

[Pg 523]

Do not have cheap, advertising dentists fix your teeth. Have the army dentist fix them and see him at least once every six months,—or see a good civilian dentist.

Do not have pictures tattooed on your skin.

Do not smoke other men's pipes.

Do not handle or touch wounds with anything but a first aid package.

Beware of chipped drinking glasses in cafés, restaurants and other places. The slightest cut from such a glass whose clipped part has been in contact with the mouth of a syphilitic person will give you syphilis.

Seek good companions like your mother and sister. Keep away from John Barleycorn. He always wants to turn you over to a harlot.

Whores and prostitutes are all diseased and will give you germs that will live to give diseases to you, your wife and your children, forty years from now. Keep away from them.

Diseases Caught from Biting Insects

1468. The more common diseases. The following are some of the more common diseases caught from the bites of certain insects: Malaria, yellow fever, and dengue fever.

The germs of malaria, yellow fever and dengue fever live in the blood, and are sucked up into the blood by mosquitoes when they bite.

Malaria germs, however, will develop only in the mosquito called, *Anopheles*.

Yellow fever germs will develop only in the mosquito called, *Stegomyia*.

Dengue fever germs will develop in the mosquito called *Culex* and in *Anopheles*.

After a period of development in these mosquitoes the germs will find their way to the spit glands, and are injected into the person whom the mosquito bites. (Note. Male mosquitoes cannot bite.)

Absolutely the only way that malaria, yellow and dengue fevers can possibly be caught is from mosquitoes.



Fig. 8
The malaria mosquito
(She stands on her head)



Fig. 9
Culex the mosquito
(She is humpbacked)

1469. How to avoid malaria, yellow and dengue fevers. To avoid these diseases, which are carried by mosquitoes, we screen all houses with fine wire screens and use mosquito nets on the beds. Also, under certain conditions we take daily doses of quinine in malarious regions.

We kill the mosquitoes.

To do this we must know their habits.

Mosquitoes all lay eggs in water. These hatch out as *wigglers* or *larvae*, which have to come to the top frequently to breathe. In about twelve days or longer they turn into *tumblers* or *pupas*, which in a few days longer come to the top when their backs split open and the mosquito comes out and flies away.

[Pg 524]

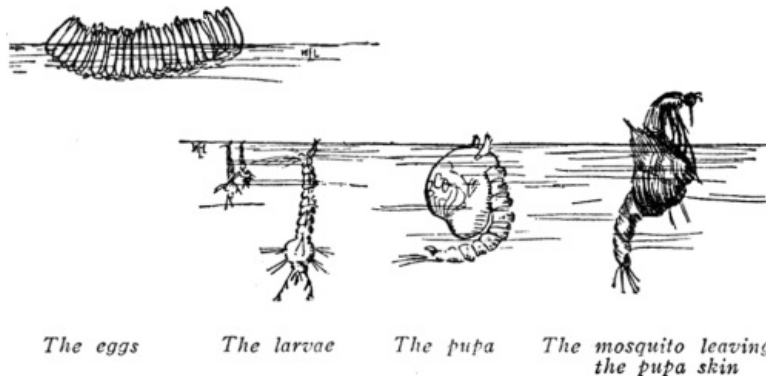

Fig. 10

The malaria mosquito is domestic like the chicken and lives around in houses hiding in the grass, bushes or dark corners and comes out to bite at night. When a settlement is abandoned the malaria mosquito moves away also. She rarely flies far from home and is not found much beyond 500 yards from a house. She lays her eggs in running clear water preferably, but she will accept water in hollow trees, between the leaves of lilies or air plants or in vases of flowers, or in cisterns and water butts.

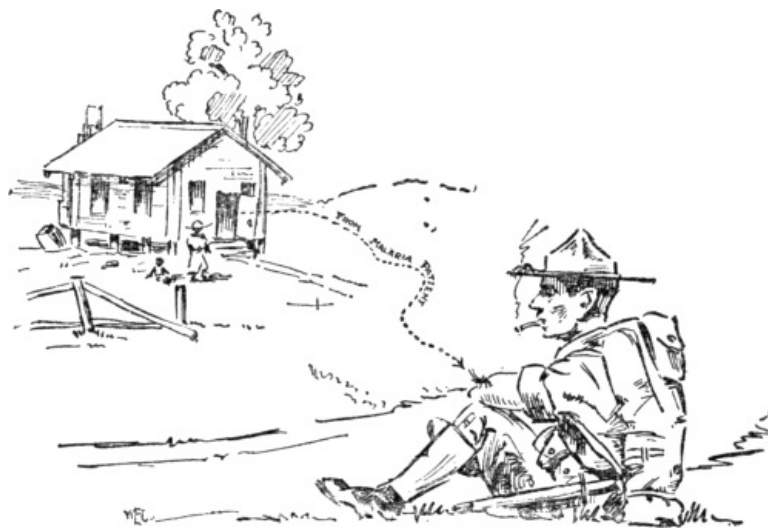

Fig. 11
Catching malaria

[Pg 525]



Fig. 12
On Guard
(No mosquito bites for him)

The yellow fever mosquito is domestic like the house cat. She hangs around the house and rarely flies as far as the next house even, preferring to travel on a visitor's coat. She will bite in the day time and will lay her eggs in any little collection of water in the house, the eaves trough, the water barrel, old tin cans or bottles, pitchers, vases or the refrigerator drip.

The dengue mosquito is a marsh and town mosquito. She flies far and well and will breed in any sort of water, even brackish.

To kill mosquitoes—

Catch them in the house; empty all water from tin cans, old barrels, etc; cover with wire all cisterns and water barrels; fill in all puddles and drain off marshes; put oil on all pools and streams to choke the wrigglers; cut down grass and bushes around houses.

CHAPTER II

[Pg 526]

PERSONAL HYGIENE

1470. The knowledge of taking care of the body is called *Personal Hygiene*, the principal rules of which are as follows:

1. KEEP THE SKIN CLEAN.
2. KEEP THE BODY PROPERLY PROTECTED AGAINST THE WEATHER.
3. KEEP THE BODY PROPERLY FED.
4. KEEP THE BODY SUPPLIED WITH FRESH AIR.
5. KEEP THE BODY WELL EXERCISED WITHOUT EXHAUSTION.
6. KEEP THE BODY RESTED BY SUFFICIENT SLEEP.
7. KEEP THE BODY FREE OF WASTES.

Sanitation is the practice of the laws of Hygiene.

1471. RULE 1. Keep the Skin clean. A dirty body invites sickness. Small troubles such as chafing, sore feet, saddle boils, sore eyes, felons, whitlows, earache, toothache, carbuncles, fleas, lice and ringworms, are all caused by lack of cleanliness, and they put men on sick report.

Owing to excessive perspiration a daily bath with soap is desirable in summer and in the tropics, the year around. At least a weekly bath should always be taken when possible. When not possible to bathe, take a good rub daily with a dry towel.

Keep your feet clean with soap and water and put on dry socks before sleeping at night. Soiled socks should be washed and hung up to dry over night.

Keep your finger nails trimmed short with scissors or knife. Never bite them off. Keep them cleaned and keep your hands washed, especially at meal times.

Underwear must be washed in clean water, hot when possible and when soiled change as soon as possible.

Do not bathe or wash your clothes in dirty water. Bathing in water containing much alkali (hard water) or fine sand or mud will make the skin smart or chafe easily and cause sore eyes.

The hair of the head should be kept well-trimmed.

1472. RULE 2. Keep the body properly protected from the weather. Clothing of the soldier is worn as a protection. Too much causes sweating and exhaustion on the march and too little causes chills and frost bite.

Be careful to rebutton the clothing in winter time after attending to Nature's calls. Cold fingers may make you careless, but the cold is merciless and may cause a bad frost bite.

The first feeling of frost bite is numbness and the first sign is a marble whiteness. Frost attacks first the nose, ears, cheeks, fingers and toes.

Sun glare and snow blindness may be prevented by colored goggles or a handkerchief tied across the face with a small slit for the eyes or by greasing the face and eyelids and rubbing in charcoal around the eyes.

[Pg 527]

1473. RULE 3. Keep the body properly fed. Your company mess is sufficient for your needs and is wholesome, provided it is well chewed. Large lumps of food take a longer time to digest than small particles do, and so they tire the stomach and also cause constipation, gas and indigestion with headache.

Do not eat food left behind in strange houses or by the enemy, nor food that smells or looks badly.

If haversack rations are issued to you, do not eat them all at the first meal, but make a division for each meal. Stuffing will make you sick on a hike and later, hunger will drive you to eat things you would not touch at other times.

Before starting on the day's hike drink all the water you can and fill your canteen with water only.

Be sure your canteen does not leak.

After starting, do not drink anything until the end of the hike.

Do not eat ice or snow to quench thirst. It will make you more thirsty. Do not drink large quantities of cold spring water when heated,—it will give you a very bad bellyache.

Do not drink whiskey or beer, especially in the field. It will weaken you and favor heat exhaustion, sunstroke, frost bite and other serious troubles.

Alcohol muddles the mind and clouds thoughts, and so causes a feeling of carelessness and silliness that may ruin some military plan, or give the whole thing away to the enemy and with it the lives of yourself and your comrades.

The soldier who drinks alcohol will be among the first to fall out exhausted.

If you use tobacco, do not chew or smoke while marching. Tobacco is only a dope and increases

the work of the heart.

A cup of hot coffee is a good stimulant.

1474. RULE 4. Keep the body supplied with fresh air. The brain, kidneys and other internal organs require oxygen (a part of the air) continually, and if deprived of it for five minutes, the body will die. Therefore, it is easy to see that we must continually get plenty of fresh air into the lungs to supply the blood which carries the oxygen throughout the body. Except in winter time when steam-heated barracks are filled with sleeping men, it is not, as a rule, difficult to get all the fresh air we need. The air in a dormitory should smell sweet and clean, even though warm. Fresh air should be continually admitted in a way that will not throw a draft on any of the sleepers.

It is much better to sleep in a cold room with fresh air than in a hot stuffy one.

Fresh air not only prevents consumption, but it will cure mild cases of consumption without other medicines.

1475. RULE 5. Keep the body well exercised without exhaustion. Exercise is absolutely necessary to good health. Lack of exercise of any set of muscles will cause them to grow flabby and weak. Outdoor sports are the best form of exercise, because they use all the body muscles, and are in the open clear air.

[Pg 528]

Exhaustion, on the other hand, not only weakens the muscles of the body, but it also lessens the vital forces and powers to resist germs.

1476. RULE 6. Keep the body rested by sufficient sleep. Give the body enough sleep. Eight hours of uninterrupted sleep are enough for the average man, and you should always have that much in every twenty-four hours. Remember your comrades need it also; so, if you come in after taps, do not make a racket with slamming doors, heavy tramping, talking or whistling. And in camp be careful not to fall over tent ropes or step on other sleepers. Do not drink coffee at night, —it will keep you awake and rob your body of needed rest.

When on the march take advantage of every halt to rest your body. As soon as the command is given to fall out, select, if possible, a dry place on the side of the road to sit or lie on. If carrying the pack, loosen it and rest back on it, in a sitting or lying position. If the march has been a long one, lie flat on your back and raise the feet in the air. This is a quick way to remove the heavy dragged feeling of the feet and legs and to rest the heart, because the blood runs out of the legs into the body.

1477. RULE 7. Keep the body free of wastes. Get into the habit of emptying the bowels at a certain hour each day. Immediately after breakfast is a good time. This is a habit that can be cultivated just like any other habit. Cultivate it. It will do much to keep you in good health.

Always empty the bowels and bladder, especially the bowels, whenever you have the least desire to do so. Do not allow a little personal inconvenience or laziness to prevent you from doing this. The wastes from the bowels and bladder, especially the bowels, are poisons that should always be expelled from the body just as soon as possible.

The free drinking of water flushes the bladder and helps to loosen the bowels. A glass of hot water soon after reveille will not only help to loosen the bowels, but it will also benefit the stomach and flush out the bladder. Some people drink a big glass of water, either hot or cold, every morning before breakfast.

Proper physical exercise and eating ripe or cooked fruits will also do much to keep the bowels open.

Pressing and rubbing *downward* with the left hand on the lower *left* side of the belly will do much to induce a movement of the bowels.

Most constipation comes from swallowing food in large chunks, drinking large quantities of cold liquids with the meals and eating heavy articles of diet, such as beans, fried pork, hot bread.

Do not get into the habit of using laxatives to keep the bowels open. Their continued use is injurious. Use the natural means suggested above.

The constant moderate use of alcohol injures the kidneys and when they become too weak to work and throw off the waste, a deadly disease, called "Bright's Disease," results.

CHAPTER III

[Pg 529]

FIRST AID TO THE SICK AND INJURED

1478. Object of teaching first aid. The object of teaching first aid, or early assistance of the

injured or sick, is not only to enable one person to help another, but also in some measure to help himself, until a surgeon or other thoroughly trained person can be seen.

It is a mistake to think you must know many things to be helpful, it is only necessary to know a few simple things, *but you must understand them clearly and be able to do them well.*

1479. Asphyxiation (suffocation) by Gas. Asphyxiation by gas is treated the same as in the case of drowning, omitting, of course, the operation of getting the water out of the body.

1480. Bite of dog.
Bite of snake.] Either requires immediate and heroic treatment.

Lose no time.

1. Prevent the poison from traveling toward the heart and brain by putting on at once a tourniquet between the wound and the heart.
2. Suck the wound and be sure to spit out the poison and rinse the mouth afterward. It is safe, if you have no cuts or sores on the lips or in the mouth.
3. Enlarge the wound with a knife (in the direction of the bone, not across) to make it bleed more freely, and again suck the wound.
4. Apply to the wound any strong acid or caustic, such as carbolic acid, lime, wood ashes or tincture of iodine, or burn it with a hot iron. Telegraph wire will do.
5. Wash out the wound with hot water and pack with equal parts of baking soda and salt, and apply a bandage.
6. Then, in the case of a snake bite, loosen the tourniquet little by little, taking about half an hour so as to permit any poison that may remain in the wound to be *gradually* absorbed by the blood. In the case of a dog bite, the tourniquet is loosened at once.

After the tourniquet has been removed, the patient must rest quietly for several hours. If he feel faint, he may have a stimulant,—alcohol, coffee or tea,—*but do not give the stimulant before the poison has been removed from the wound*, because stimulants increase the heart beats and thereby hurry the poison into the blood.

If the dog is not mad (rabid), the wound does not need treatment different from any other kind of a wound.

When bitten by a snake, kill it, if possible, and have it shown to a doctor for examination.

1481. Bleeding. The following comparison between the blood and the water in a city will enable you to understand easily the question of bleeding:

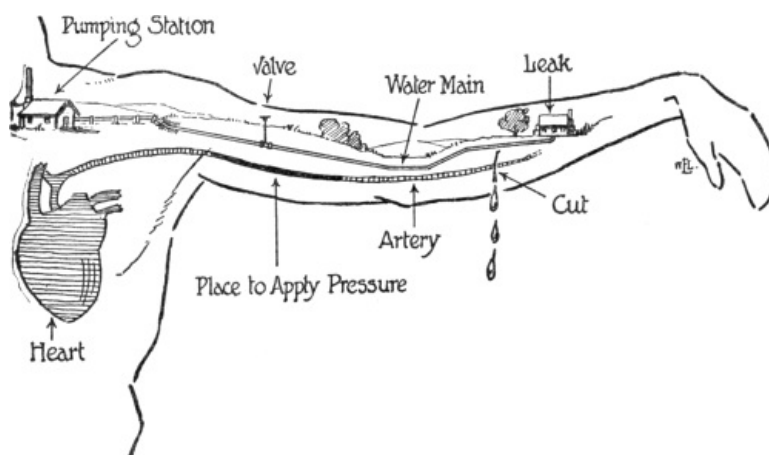

Fig. 1

The {water/blood} flows from a pump called {waterworks/heart} through {rigid pipes/elastic tubes} called {watermains/arteries}. When there is a {leak/bleeding} the {plumber/doctor} stops the flow of the {water/blood} by {turning a key valve/pressing the blood tube shut} between the {waterworks/heart} and the {leak/bleeding cut} and then proceeds to repair the leak {by soldering/by sewing or by bandaging}. He then turns on the {water/blood} by {opening the valve in the water main/removing pressure on the blood tube}.

Fig. 2 shows where pressure with the thumb will squeeze the blood tube between the thumb and the bone.



Fig. 2

Pressure with thumb at 1 checks bleeding of left side of chin cheek and jaw.

Pressure at 2 stops bleeding from big blood tube on left side of head and neck and face.

Pressure at 3 controls bleeding in arm pit and shoulder.

Pressure at 4 checks bleeding in arm pit and anywhere down the arm and hand.

Pressure at 5 stops bleeding of arm and hand.

Pressure at 6, on either leg, stops bleeding of leg and foot.

In addition to the pressure raise the leg or arm or head above the heart. This will slow the flow of the blood and lessen leakage.

However, one cannot hold the thumb forever on the blood tube, so we make an artificial thumb, called a *tourniquet*, which is a pebble or other hard object wrapped in some soft material (to prevent injury to flesh), which is pressed down on the blood tube and held in place by a strip of any material which can be tied so as to keep up the pressure.

[Pg 531]

A tourniquet, therefore, is like the valve in a water main.



The pebble

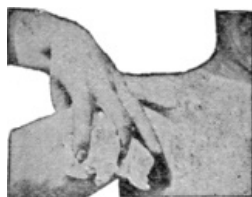

The pebble wrapped to protect the flesh

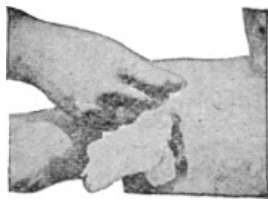

The bandage tied around over the pebble

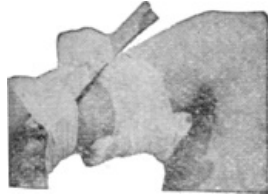

The bandage twisted tightly by means of a windlass (stick) which is held by another bandage



This shows pressure applied by tourniquet (also called Spanish windlass) instead of the hand and by direct pressure of the First Aid Packet

Fig. 3

The above diagrams show how a tourniquet is applied.



Fig. 4
Bandage to stop bleeding in arm

When no one is around to assist you, sometimes it will be possible to plug the wound in your own body with the first aid packet or with your thumb or handkerchief.

When the bleeding is slight, or is from the scalp or palm of the hand, or sole of the foot, direct pressure upon the wound itself with the pad of the first aid package will often be sufficient to stop the leak.

Nature when left alone stops the leaks with her own solder, called blood-clot, which forms in the cut ends of blood tubes and corks them or seals them up until a scar forms a permanent seal.



Fig. 5
Bandage to stop bleeding in foot

[Pg 532]



Fig. 6
Arm blown off at elbow
NOTICE:

1. Bandage on stump.
2. Tourniquet below to check bleeding.
3. Arm held upright to lessen bleeding.
4. Strap supports arm and

1482. The dangers from a tourniquet are:

1. Gangrene,—that is, the death of a limb caused by the lack of blood, which has been cut off by the tourniquet. By watching the toes and finger tips and loosening the tourniquet if they are becoming blue black and remain white when pinched, gangrene may be prevented. However, the wound should be plugged before loosening the tourniquet.

2. Injury to nerves from pressure which may cause palsy (paralysis). However, that will generally pass off in a few days.

also acts as a tourniquet.



Fig. 7
Compound fracture

1483. Broken Bones (Fractures). A broken bone or fracture is known by pain in a particular place that hurts on movement or when touched. Also, by a deformity or a movable lump, caused by the broken end of the bone.

A broken bone should be handled with the greatest possible care. Careless handling may cause the broken ends to pierce the flesh and stick out through the skin. This is called a **compound** fracture, and is serious, because it adds fuel to the fire by making a doorway for germs to enter, which may cause death or the loss of the limb. Furthermore, careless handling may make the bones grow together in a bad position, causing a deformity.



Break of UPPER arm bone. Pulling the broken bones out of flesh and into place



Treatment for break of upper arm bone
1. Padding of grass.
2. Splints put on FRONT and BACK.
3. Splints extend beyond elbow joint.
4. Arm is supported by a sling.



Treatment for break of both bones of lower arm
1. Plenty of grass padding to protect the flesh.
2. The splints are put FRONT and BACK and bound snugly. The hand is included.
3. The whole dressing is held up by a sling.

Fig. 8

The best way to treat a broken leg or arm bone is as follows: ([Fig. 8.](#))

Pull until the ends come together. You can tell this by the relief the patient feels and by the limb assuming its proper length,—that is, the same length as the other side.



Fig. 9
Points to note:
Plenty of grass between the legs.
Plenty of grass between injured leg and splint.
Splint extends from arm pit to foot.
The other leg is used for a splint.
Plenty of strapping to keep leg quiet.

1484. To keep the ends of the bones in place, fasten to the limb two boards or any other substance that will not bend. Such boards or other substance are called splints. They act as artificial bones. All splints should be well padded with some soft material like raw cotton waste, grass (be sure the grass contains no biting insects), leaves, hay or excelsior, to prevent pressure of the soft flesh on the ends of the bones.

When the thigh bone is broken, put a splint from the arm to the ankle and use the other leg as a splint. Fasten them by bandages, belts, gun sling, etc., passed around the chest, waist, hips, knees and ankle.

When an arm is put in a splint, hang the hand and forearm in a sling. It will give much relief.

When the jaw is broken, the upper jaw makes a good splint.

When the collar bone is broken this makes a good treatment: ([Fig. 10.](#))



Broken collar bone

The left collar bone is broken. Therefore, pull BOTH shoulders backward away from the breast bone (same action as for broken arm bone) and hold in position with bandage or straps.



Broken collar bone (left side)

When the shoulders are pulled back then the hand is bound close to the chest high up. This prevents it from flopping and so twisting the broken ends of the collar bone.

Fig. 10



Fig. 11

Treatment for broken ribs, left side

The patient breathes all the air out of the chest and at that moment the strap is buckled tightly. This prevents the broken ends of the ribs from tearing the flesh or the lungs. Notice the roll of shirt which acts as a pad.

A broken rib is treated by putting a wide strap or bandage around the chest and drawing it tight while all the air is breathed out.

This keeps the rib quiet and the man will breathe with his belly instead of his chest.

A broken skull usually makes a man unconscious and may cause death. It is recognized by a wound or swelling of the scalp and a dent in the skull. A doctor should be called at once. Always examine an unconscious man for injury to the head.

1485. Burns. If clothing sticks to the burn, do not try to remove it, but cut around it. Prick blisters at both ends with a perfectly clean needle, and remove the water by gentle pressure, being careful not to break the skin.

A good application for a burn is carbolic acid dissolved in water (a teaspoonful in a pint of water), or tincture of iodine dissolved in water (one teaspoonful in a pint of water, to which is added as much salt as will cover a dime), or olive oil, vaseline or butter.

Lacking the remedies named above, ordinary *baking* soda or flour may be dusted on the unbroken skin, or a cloth dampened with salt water that has been boiled, to which may be added the same amount of whiskey or brandy as there is water.

Another application for burns recommended by some, is the scraping of a raw potato, renewed when it feels hot.

[Pg 535]

Different burns should be treated as follows:

Sunburn,—treat with olive oil, vaseline or butter, or with a glycerine or witchhazel, applying with a dampened cloth.

Quicklime or lye,—treat with vinegar.

Carbolic acid,—treat with alcohol.

Other acids,—treat with baking powder or lime water.

1486. Burning clothes, particularly those of women and children, has been the unnecessary cause of many horrible deaths, either from ignorance of the proper means of extinguishing the flames, or from lack of presence of mind to apply them. A person whose clothing is blazing should (1) immediately be made to lie down—be thrown if necessary. The tendency of flames is upward, and when the patient is lying down, they have not only less to feed upon, but the danger of their reaching the face, with the possibility of choking and of ultimate deformity is greatly diminished.

(2) The person should then be quickly wrapped up in a coat, shawl, rug, blanket or any similar article, preferably woolen, and never cotton, and the fire completely smothered by pressing and patting upon the burning points from the outside of the envelope.

The flames having been controlled in this way, when the wrap is removed, great care should be taken to have the slightest sign of a blaze immediately and completely stifled. This is best done by pinching it but water may be used. Any burns and any prostration by shock should be treated in the manner prescribed for them.

1487. Bruises. The best treatment for a bruise is heat.

A hot brick or a bottle of hot water wrapped in cloth, towels wrung out of hot water, or even an electric light bulb, will give much relief.

However, always remember this: Never put the hot object on the bare skin—always wrap the source of heat in a thick cloth to hold the heat in and at the same time protect the skin. If not practicable to do this wrap the source of heat, then spread a towel over the skin before applying the hot object.

If you use an electric bulb, watch it closely, as it will char and possibly set things on fire.

The above treatment is also excellent for lumbago, stiff neck, and stiff muscles.

A tub bath as hot as you can stand it is fine for refreshing tired, stiff muscles. It is also good for lumbago.

1488. Chiggers. Apply kerosene oil. Bacon is also excellent, and so is butter or lard with salt.

1489. Choking. Foreign body in the throat. The common practice of slapping the back often helps the act of coughing to dislodge foreign bodies in the windpipe.

If this does not succeed, have the patient lie over a chair with his head down low or hold him as in the first step to revive a drowning person and have him cough. When in either of these positions have some one slap him on the back so as to induce coughing.

The above failing, give him a large amount of warm water with a little salt, mustard or baking soda in it, and then have him put his finger in his throat so as to induce vomiting which will often bring up the obstruction.

[Pg 536]

In children, and even in adults, the expulsion of the body may be facilitated by lifting a patient up by the heels and slapping his back in this position.

If none of the methods above described are successful, summon a physician, taking care to send him information as to the character of the accident, so that he may bring with him the instruments needed for removing the obstruction.

1490. Cuts. Small cuts should be treated with tincture of iodine or washed with alcohol (bay rum or listerine will do) and bandage up. Large wounds may be similarly cleaned and then closed by adhesive plaster.

1491. Diarrhoea. Apply warm bandages to the belly. Some woodsmen recommend the following: Fire brown a little flour to which two teaspoonfuls of vinegar and one teaspoonful of salt are added; mix and drink. They claim this is a cure nine cases out of ten. A tablespoonful of warm vinegar and teaspoonful of salt will cure most severe cases. Also, hot ginger ale or hot water containing a teaspoonful of witch hazel is good. Repeat any of the above drinks about every hour.

Take a purgative, which will usually expel the offending cause, generally too much undigested food.

1492. Dislocations. The place where two bones come together is called a joint.

When two bones forming a joint are knocked apart, it is called a *dislocation*, and the bones are said to be *out of joint*.

The first sign of a dislocation is the accident.

The second sign is immediate interference with the motion of the joint and awkwardness in using the limb.

The third sign is deformity of the joint,—it looks queer when compared with the same joint on the other side.

If you are unsuccessful after trying several times to replace a dislocation, get a doctor.

If no doctor is available, make the man sick by having him drink some warm salt water and then put his finger in his throat.

When he vomits the muscles and ligaments (tissue connecting the joints) will relax and you may

be able to get the bone back in place.

After replacing the bones put the joint at rest with a large compress and bandage.

When uncertain as to whether you have to deal with a broken bone or a dislocated joint, give treatment for a broken bone, because rest and quiet for the injured part are good in either case.

The following diagrams show the usual methods of replacing dislocations:

To put the arm bone back into the shoulder socket

[Pg 537]



1ST MOVE
Rest your weight at elbow, pulling downward, until the muscles at the shoulder are tired and will stretch.



2ND MOVE
Swing the elbow across, close to the chest, and place the hand on other shoulder.



3RD MOVE
Keep the elbow close to the chest and bring the hand forward as if held out for a penny. This should twist the bone into the socket.

Relocating the jaw



When the jaw bone is out of place, the man cannot shut his mouth. Put both thumbs (protected by a handkerchief) on the lower teeth and with the forefingers at the angles of the lower jaw push down in the back of the jaw.

Relocating thumb

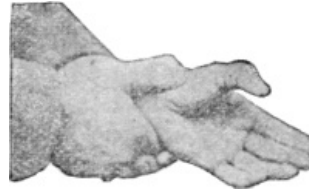

When the thumb bone is dislocated it must be PUSHED into place—not pulled. Relocating finger

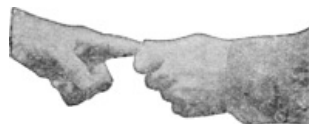

Pull the finger bone back into place.

Fig. 12

1493. Drowning. Rescuing. Approach the drowning man from behind, seizing him by the coat collar, or a woman by the back hair, and tow at arms length to boat or shore. Do not let him cling around your neck or arms to endanger you. Duck him until unconscious if necessary to break a dangerous hold upon you; but do not strike to stun him.

A drowning person *does not* come to the top three times before giving up.

[Pg 538]

Reviving. When a person is apparently drowned he is unconscious and not breathing because his lungs are full of water and his skin is blue and cold because no air is getting into his blood to redden it and warm it; *remember* the heart does not stop until some time after the breathing stops. If we can get air into the blood and start breathing again before the heart stops we can save the patient's life. If we cannot get the breath started in time the heart stops and the patient is then dead.

Our problem then is this:

1. To get the water out of the lungs.
2. To get the air into the lungs and start the man breathing before the heart stops.

Emptying the lungs is precisely similar to emptying a bottle.

The lungs are the bottle, the windpipe is the neck of the bottle and the cork of the bottle may be

the tongue turned back in the throat or mud and leaves from bottom of the pool and bloody froth in the nostrils. We therefore—

1. [Pull out the cork.
Remove mud, mucus, etc., and pull the tongue forward.



Fig. 13
Pulling out the cork

2. [Turn the bottle neck down to pour out the contents.
Place the patient's head lower than his chest so the water will run out.

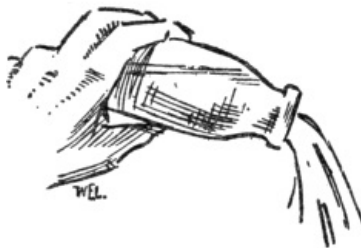

Fig. 14

Then lay the patient on a blanket, if possible, and on his stomach, arms extended from his body beyond his head, face turned to one side so that the mouth and nose do not touch the ground. This position causes the tongue to fall forward of its own weight and so prevents it from falling back into the air passages. Turning the head to one side prevents the face coming into contact with mud or water during the operation. [Pg 539]

Kneel and straddle the patient's hips, facing his head.

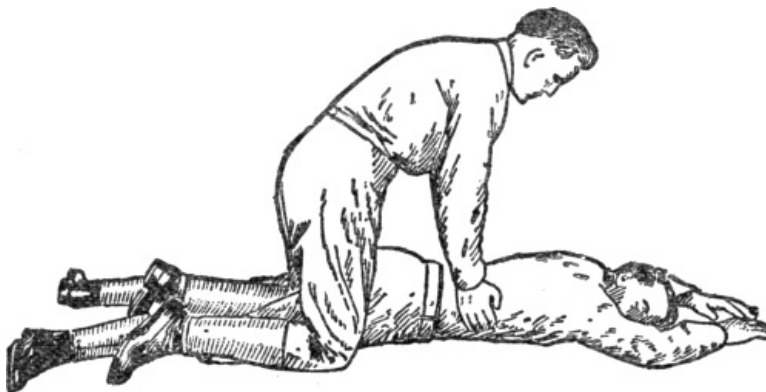

Fig. 15

Roll up or rip off the clothing so as to get at the bare back.

Locate the lowest rib, and with your thumbs extending in about the same direction as your fingers, place your spread hands so that your little finger curls over the lowest rib. *Be sure to get the hands well away from the back bone,*—the nearer the ends of the ribs the hands are placed without sliding off, the better it is.

Then with your arms *held straight*, press down **SLOWLY AND STEADILY** on the ribs, bringing the weight of your body straight from your shoulders. *Do not bend your elbows and shove in from the side.*

Release the pressure suddenly, removing the hands from the body entirely, and thus allowing the chest to fill with air.

Wait a couple of seconds, so as to give the air time to get into the blood. This is most important.

Repeat the pressure and continue doing so, slowly and steadily, pressing down at the rate of ordinary breathing. That is to say, *pressure and release of pressure (one complete respiration)*

should occupy about five seconds. Guide yourself by your own deep, regular breathing, or by counting.

Keep up for at least one hour the effort to revive the patient; and much longer if there is any sign of revival by way of speaking, breathing, coughing, sneezing or gurgling sounds.

Do not stop working at the first signs of life, but keep it up until the patient is breathing well and is conscious. If you stop too soon he may stop breathing and die.

Persons have been revived after two hours of steady work, but most cases revive within about thirty minutes.

If you are a heavy man, be careful not to bring too much force on the ribs, as you might break one of them.

[Pg 540]

In the case of women or thin persons place a roll of clothing under them at the waist line before beginning the pressure.

If you happen to be of light build and the patient is a large, heavy person, you will be able to apply the pressure better by raising your knees from the ground, and supporting yourself entirely on your toes and the heels of your hands, properly placed on the floating ribs of the patient.

Do not attempt to give liquids of any kind to the patient while he is unconscious, for he cannot swallow them. They will merely run into his windpipe and choke him, and furthermore, it will take up valuable time.

However, after the patient has regained consciousness you may give him hot coffee or hot whiskey, punch or aromatic spirits of ammonia (a teaspoonful in water).

Then wrap up the patient warmly in hot blankets with hot water bottles, and take him to the nearest hospital or put him to bed and send for a doctor. Why? Because the dirty water in the lungs has damaged the lining and the patient is in danger of lung fever and needs care and nursing.

Aromatic spirits of ammonia may be poured on a handkerchief and held continuously within about three inches of the face and nose. If other ammonia preparations are used, they should be diluted or held farther away. Try it on your own nose first.

The above method of artificial respiration is also applicable in cases of electric shock, suffocation by gas and smoke.

1494. Earache. Put a teaspoonful of salt into a quart of water and add 6 teaspoonfuls of tea. Boil it. As soon as it is cool enough to stand the finger, drip some into the nostrils until it falls into the throat. Clear out the nose and throat by sniffing,—*do not blow* the nose.—and then gargle with the rest of the remedy as hot as can be taken, holding each mouthful well back in the throat. This will often open up the tubes running from the ears to the throat, and relieve the pressure against the ear drum. In addition, a little hot oil may be dropped into the ear. Repeat the treatment in one-half an hour if not successful first time.

1495. Ear, foreign body in. Lay the head over, with the affected ear up, and pour in some warm oil or soap suds. This will float the thing up, unless it be a vegetable such as a grain of corn or a bean. Turning the affected ear down and then jumping, jerking the head, or pounding it gently, may dislodge it.

A little peroxide of hydrogen poured into the ear will often dislodge the substance, especially if it be wax.

In case of an insect, a bright light held near the ear will often cause it to leave the ear to go to the light.

1496. Electric Shock. Failure of respiration following an electric shock by lightning or live wire is treated the same as in the case of drowning, omitting, of course, the operation of removing the water out of the lungs.

Do not try to pull a man away from a live wire until you have put on rubber overshoes or gotten a *wooden* stick with which to get the wire away from him. Otherwise you will yourself get a shock.

[Pg 541]

1497. Eye, foreign body in. Close the eye for a few moments and allow the tears to fill the eye; upon opening it, the body may be washed out by them.

Never rub the eye.

The foreign body can often be removed by keeping the eye open with one hand and splashing water into it with the other, or by dipping the eye into clean water while holding the eyelid open with the hand.

If the body lies under the lower lid, make the patient look up, and at the same time press down upon the lid; the inner surface of the lid will be exposed, and the foreign body may be brushed off

with the corner of a handkerchief.



Fig. 16

If the body lies under lid, (1) grasp the lashes of the upper lid and pull it down over the lower, which should at the same time, with the other hand, be pushed up under the upper. Upon repeating this two or three times, the foreign body will often be brushed out on the lower lid.

(2) If this fails, the upper lid should be turned up; make the patient shut his eye and look down; then with a pencil or some similar article press gently upon the lid at about the middle, and grasping the lashes with the other hand, turn the lid up over the pencil, when its inner surface will be seen, and the foreign body may readily be brushed off.



Fig. 17

If the body is firmly stuck in the surface of the eye, a careful attempt may be made to lift it out with the point of a needle. If not at once successful, do not try again, as you may injure the sight.

Lime, plaster or whitewash in the eye should be washed out with a very weak mixture of vinegar and water. Acids in the eye may be washed with baking soda in water. Olive oil will also afford relief.

After the removal of a foreign body from the eye, a sensation as if of its presence often remains. People not infrequently complain of a foreign body when it has already been removed by natural means. Sometimes the body has excited a little irritation, which feels like a foreign body. If this sensation remains over night, the eye needs attention, and a surgeon should be consulted; for, it should have passed away, if no irritating body is present.

After the removal of an irritating foreign body from the eye, salt water should be poured into it, then butter, lard or olive oil may be used for a salve.

1498. Fainting. Fainting is caused by the blood leaving the head. Therefore, we must get the blood back into the head, which is done by placing the patient on his back, with the head lower than the rest of the body. If necessary, make, by digging, a slight depression in the ground for the head, neck and upper part of shoulders. Also, the head may be placed lower than the rest of the body by putting a couple of folded blankets, or a few folded coats or any other suitable article under the body: also, by raising the feet by hand or otherwise. The clothing should be loosened by unbuttoning and the patient fanned. Give him as much fresh air as possible,—so, do not let people crowd around him. Mop the face and forehead with a handkerchief soaked in cold water.

[Pg 542]

1499. Fish hook. If a fish hook gets caught in the flesh, push it on through and when the end sticks out, break off the hook and pull it out the other way. Put tincture of iodine on the wound and bandage.

1500. Fits. The man falls over suddenly unconscious in a convulsion, which continues until he is blue in the face, when he gradually quiets down and regains consciousness. He is liable to injure himself by the fall and by biting his tongue. Put a stick or cork between his teeth and let him lie quietly undisturbed. Don't try to hold him down or make him sit up. He will come to no harm on the floor and you cannot stop the fit. Ammonia on a handkerchief held under the nose to smell will assist reviving consciousness. Put him in the hospital at once.

1501. Fracture. See, "[Broken Bones.](#)"

1502. Freezing. If a man is overcome by the cold, do not take him into a warm room, or heated tent. Put him into a cool room without draughts and get a doctor at once. Meanwhile loosen his clothing and rub arms and legs towards the heart with cold water and a towel or sponge, using pressure.

When he revives give him hot drinks and wrap him up well in hot blankets and put him in the hospital.

When freezing to death a man feels overcome with sleepiness and stupor. Take a switch or stick and beat him unmercifully. Remember that falling to sleep means death.

1503. Frost-bite. The best way to get frost-bitten is to have on damp clothing, such as wet shoes and socks or mittens. The first feeling of frost bite is numbness, and the first sign is marble whiteness.

Treatment. Rub the frozen part briskly with snow or ice cold water, if the frost-bite has just occurred. If it has been frozen more than fifteen minutes, *rub very gently* with snow, cold water or coal oil (kerosene). If you rub hard, it will break the frozen flesh.

Returning pinkness is a sign of thawing; if the parts turn a dark color, see a surgeon at once, for it means gangrene (death of the flesh).

When thawed out apply plenty of oil, tallow or vaseline.

If gangrene has set in and no doctor is available, then treat as a burn.

By all means keep away from heat. To toast frost-bitten fingers or toes before a fire is liable to result in chilblains.

1504. Headache. Among troops headache is usually due to intestinal indigestion, combined with a congestion of the stomach. Take a tablespoonful of Worcestershire sauce or 5 drops of tobasco sauce in a tumbler of hot water as a drink and put a small piece of soap up into the bowel to cause a movement.

[Pg 543]

1505. Heat exhaustion. The man falls out in a faint while marching, or on fatigue or parade. He looks pale, his body is clammy and cold, his breathing is sighing and heart fluttering. *What is the matter?* His heart is weak from poisons in the blood, usually alcohol, but often too much carbonic gas and too little oxygen. This occurs when men are soft-muscled: so, young soldiers, recruits and fat soldiers and especially those who drink alcohol, use drugs or smoke or chew tobacco while hiking, are the first to have it.

Treatment. Loosen the man's clothing, remove his pack, lay him on his back in the shade, with head and shoulders lower than his hips and raise his feet in the air. This will make the blood flow to the heart and brain. If he has fainted, slap the bare chest with the hand or a wet towel and briskly rub the arms towards the heart. If he does not revive, apply hot bottles, or bricks to the chest and abdomen, and ammonia to the nose, as a smelling salt. Do not give stimulants until he is conscious. He should ride in the ambulance, or go to the hospital.

1506. Lightning. A man struck by lightning is treated the same as in the case of drowning, omitting, of course, the operation of getting the water out of the lungs.

1507. Nose, foreign body in. If it cannot be sneezed out, lean the head back and pour a little oil into the nostril. Then snift and blow the nose alternately. If this is not successful, take a lead pencil and try to push the object straight back into the throat. This must be done very gently.

1508. Poison. When poison has been swallowed, cause the patient to take a large quantity of luke-warm water and make him vomit by putting his finger in his throat. Repeat this and then have him swallow the white of two eggs or some milk into which raw flour or corn-starch has been stirred.

If you know he took bichloride of mercury, you may increase the amount of eggs and give one-half glass of weak lime water.

If you know he took carbolic acid, give him alcohol (pure alcohol or in the form of gin or whiskey) and plenty of it in order to neutralize the acid.

Get a doctor as soon as possible, and save the vomit and poison not taken, for him to see.

1509. Scalds. Apply at once common baking soda or olive oil and cover with a bandage. To sprinkle with flour is also good.

1510. Scratches of cats and other animals. Apply tincture of iodine or wash with soap and water.

1511. Shock. In case of collapse following an accident, treat the accident; then treat as for fainting. Apply hot plates, stones or bottles of hot water, or an electric light wrapped in towels over the stomach. Wrap up warmly. Keep the patient quiet, in the dark, and send for a doctor.

1512. Snow or sun blindness. Smear the nose and face about the eyes with charcoal, and wear a cloth over the face with small holes for the eyes.

1513. Sore throat. Gargling with hot strong tea or hot water and salt is often effective.

[Pg 544]

Listerine diluted in water and used as a gargle is also good.

Peroxide of hydrogen is a good gargle.

1514. Spider bite. Apply a cloth dampened with alcohol or weak ammonia and water.

1515. Suffocation by gas. See "[Asphyxiation by gas.](#)"

1516. Sprains. The regular medical treatment is to plunge a sprained ankle, wrist or finger, into water as hot as can be borne at the start, and to raise the heat gradually thereafter to the limit of endurance. Continue for half an hour, then put the joint in a hot wet bandage, reheat from time to time, and support the limb in an elevated position,—the leg on a chair or stool; the arm carried in a sling. In a day or two begin gently moving and kneading the joint, and rub with liniment, oil or vaseline.

As a soothing application for sprains, bruises, etc., the virtues of witch hazel are well known.

1517. Stings. Stings of bees, jelly fish and other stinging animals are treated with a very weak

solution of ammonia in water applied as a lotion. Or apply a very weak solution of carbolic acid in water, a strong solution of baking powder, a slice of crushed raw onion, a moist quid of tobacco, witch hazel, listerine, or a paste of clay.

Before applying any of these remedies, extract the sting, if left in the wound. Also, work out as much of the poison as possible by massaging and sucking the wound.

1518. Sunburn. Treat with witch hazel or listerine or vinegar well diluted with water.

1519. Sunstroke. In sunstroke the man has a blazing red face, dry, burning hot skin; agitated heart; snoring breathing; a high fever, and is unconscious and delirious. *What is the matter?* The part of the brain which regulates the heat of the body is overcome by the heat and loses control,—the man is entirely too hot all the way through.

Treatment. First of all remove the pack and shoes and loosen the clothing. Then souse the man, clothing and all, with water. Lay him in the shade and fan him, keeping him covered and wet. This will cool him off without chilling too much. If possible, rub the chest and legs, but not the belly, with ice.

1520. Wounds. Wounds may be made in every degree of size, from the jab of a splinter to the loss of a part of the body from shrapnel.

No matter what form of the wound or the cause, we know the following fact to be of the utmost importance: A wound without germs in it will heal rapidly without pain, redness, heat, or pus and the patient will have no fever. He will eat his regular meals and act as though well.

Such wounds we see made by surgeons when operating. On the other hand, wounds infected with germs are painful, hot, angry, red, and swollen and form large quantities of pus or matter.

Pus is a mixture of germs, blood and the flesh that they have destroyed. This pus prevents wounds from healing and often burrows under the skin, forming abscesses which cause fever and chills, and the pus enters the blood causing delirium and death.

[Pg 545]

Our one aim in treating wounds is to keep out germs, and we accomplish this by means of the first aid packet.

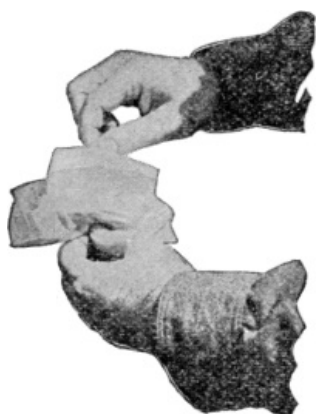

Fig. 18

First Aid Packet

After the removal of packet from tin can, open the wax paper and hold the package as shown.

- 1. Left hand holds the wax paper.**
- 2. Right hand holds the bandage.**

1521. The first aid packet consists of two gauze compresses sewed to two cotton bandages. They are sealed in wax paper. There are also two safety pins wrapped in wax paper. These articles are placed in an airtight metal case which protects them from contamination.

Now, the one important fact about this first aid packet is that the bandage compresses and safety pins have been *sterilized*,—that is, they contain no living germs of any kind. It is, therefore, perfectly safe to put on a wound, *provided the pad touches the wound before it touches anything else and provided that the wound has not been handled.* Therefore, do not wash a fresh clean wound.

CAUTION. Have the wound ready before you open the packet. Do not touch the gauze pad with ANYTHING. Do not breathe on it, and be especially careful not to cough or sneeze over it. These things put germs on it which will grow in the wound.

By observing these instructions you may save a man's life. By not observing them, you may cause his death, or cause him much pain and suffering.

The life of a wounded man is often in the hands of the first one who attends him.

It is said that since the adoption of the first aid packet by armies, it has done more than everything else to save the lives of those wounded in battle by preventing the infection of wounds.

In an emergency a pad from any kind of cloth may be boiled for ten minutes to kill the germs, the water drained off to allow it to cool, and then placed on the wound. Or, the pad may be held over a clear fire until it is fairly scorched; then let it cool. A little charring of the surface will do no harm. Any kind of bandage may then be used to hold it in place.

[Pg 546]

When a bullet strikes a man first, the wound is clean cut and germ free and it will heal rapidly. If, however, it strikes something first, and bounces off (ricochets) and then strikes a man, it will be knocked into an irregular shape and, therefore, cause a ragged wound with much bruising. What is more important, such a bullet will carry germs into the wound from the object struck, and almost surely some shreds of clothing.

When a wound is infected it is extremely difficult to kill the germs (disinfect). Such a wound, before applying the first aid dressing should be painted with a tincture

of iodine, or alcohol or be well washed with boiled salt water.

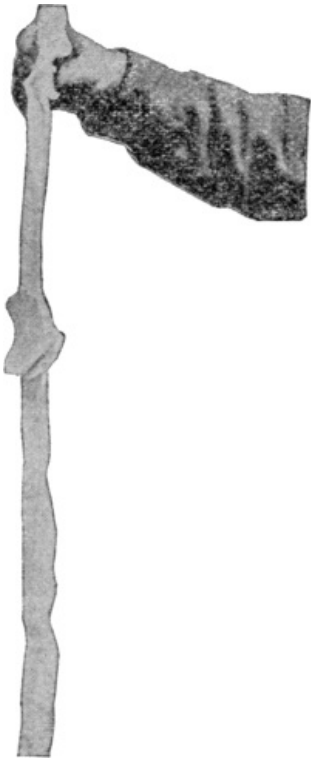

Fig. 19

First Aid Packet

Shake out packet with right hand so that the pad (or compress) does not touch anything until placed on the wound.

1522. The illustrations below show improvised litters.

[Pg 547]

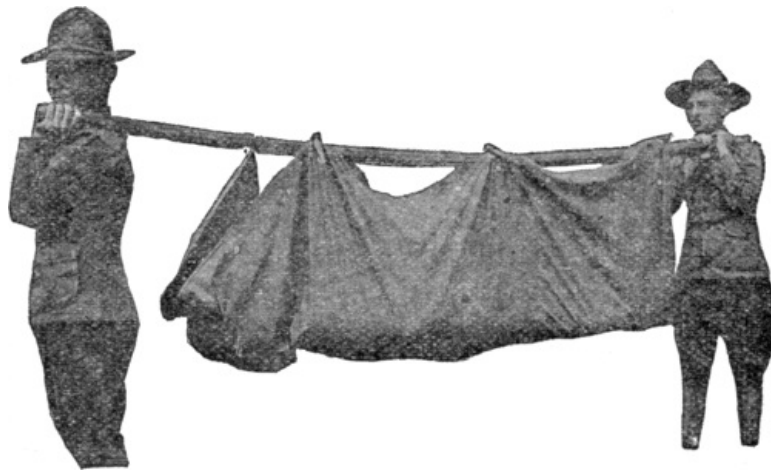

Litter made of one-half shelter tent, three shelter tent pins and one tent or other pole



Litter made of two poles, two coats and one belt. The coats are buttoned and the sleeves turned inside out, the poles being run through the sleeves. The belt is used as a head rest



The coat litter in use

Fig. 20

PART VI

[Pg 548]

MILITARY COURTESY AND KINDRED SUBJECTS

CHAPTER I

[Pg 549]

MILITARY DEPARTMENT AND APPEARANCE—PERSONAL CLEANLINESS—FORMS OF SPEECH—DELIVERY OF MESSAGES, ETC.

1523. Military Deportment and Appearance. The enlisted man is no longer a civilian but a soldier. He is, however, still a citizen of the United States and by becoming a soldier also he is in no way relieved of the responsibilities of a citizen; he has merely assumed in addition thereto the responsibilities of a soldier. For instance, if he should visit an adjoining town and become drunk and disorderly while in uniform, not only could he be arrested and tried by the civil authorities, but he could also be tried by the summary court at his post for conduct to the prejudice of good order and military discipline. Indeed, his uniform is in no way whatsoever a license for him to do anything contrary to law and be protected by the government.

Being a soldier, he must conduct himself as such at all times, that he may be looked upon not only by his superior officers as a soldier, but also by the public as a man in every way worthy of the uniform of the American soldier.

Whether on or off duty, he should always look neat and clean, ever remembering that in bearing and in conversation he should be every inch a soldier—shoes must be clean and polished at all times; no chewing, spitting, gazing about, or raising of hands in ranks—he should know his drill, his orders and his duties—he should always be ready and willing to learn all he can about his profession—he should never debase himself with drink.

A soldier's uniform is more than a mere suit of clothes that is worn to hide nakedness and protect the body. The uniform of an army symbolizes its respectability, its honor, its traditions, and its achievements, just as the flag of a nation symbolizes its honor, dignity and history. Always remember this, and remember, too, that the soldier who brings reproach upon his uniform is in the same class as the priest who brings dishonor upon his robes.

It is not given to every man to wear the uniform of his Country's army,—it is an honor and a privilege to do so, and no individual has a right to abuse this honor and privilege by bringing the uniform into disrepute through misbehavior.

It should be remembered that the soldiers of a command can make the uniform carry distinction and respect, or they can make it a thing to be derided.

The soldier should take pride in his uniform.

A soldier should be soldierly in dress, soldierly in carriage, soldierly in courtesies.

[Pg 550]

A civilian owes it to himself to be neat in dress. A soldier owes it to more than himself—he owes it to his comrades, to his company—he owes it to his country, for just so far as a soldier is slack so far does his company suffer; his shabbiness reflects first upon himself, then upon his company and finally upon the entire Army.

It is a fact known to students of human nature that just in proportion as a man is neatly and trimly dressed is he apt to conduct himself with like decency. The worst vagabonds in our communities are the tramps, with their dirty bodies and dirty clothes; the most brutal deeds in all history were those of the ragged, motley mobs of Paris in the days of the French Revolution; the first act of the mutineer has ever been to debase and deride his uniform.

The man who misbehaves himself in uniform in public creates a bad impression of the whole command, as a result of which his comrades must suffer. Remember that a man in the uniform of

a soldier is conspicuous,—much more so than a civilian,—and consequently any misconduct on his part is more noticeable than if done in civilian clothes. The man who deliberately besmirches the uniform of his Country's army by appearing in public drunk or by other misconduct, not only fouls his own nest, but he also dishonors the uniform worn by his self-respecting comrades.

It is a well known fact that laxity in dress and negligence in military courtesy run hand in hand with laxity and negligence in almost everything else, and that is why we can always look for certain infallible symptoms in the individual dress, carriage and courtesies of soldiers.

Should a soldier give care and attention to his dress?

Yes; not only should a soldier be always neatly dressed, but he should also be properly dressed—that is, he should be dressed as required by regulations. A soldier should always be neat and trim, precise in dress and carriage and punctilious in salute. Under no circumstances should the blouse or overcoat be worn unbuttoned, or the cap back or on the side of the head. His hair should be kept properly trimmed, his face clean shaven or beard trimmed and his shoes polished, his trousers pressed, the garrison belt accurately fitted to the waist so that it does not sag, his leggins cleaned, his brass letters, numbers and crossed rifles polished, and his white gloves immaculate.

Should a man ever be allowed to leave the post on pass if not properly dressed?

No; never. The Army Regulations require that chiefs of squads shall see that such members of their squads as have passes leave the post in proper dress.

Should a soldier ever stand or walk with his hands in his pockets?

No; never. There is nothing more unmilitary than to see a soldier standing or walking with his hands in his pockets.

The real soldier always stands erect. He never slouches.

Is it permissible, while in uniform, to wear picture buttons, chains, watch charms, etc., exposed to view?

No; it is not.

May the campaign hat or any other parts of the uniform be worn with civilian dress?

[Pg 551]

No; this is prohibited by the Uniform Regulations, which especially states that when the civilian dress is worn it will not be accompanied by any mark or part of the uniform.

May a mixed uniform be worn—for example, a cotton olive drab at and woolen olive drab breeches?

No; under no circumstances.

When the company commander or any other officer sends for a soldier to report to him in the company office or any other place, the soldier must report in proper uniform.

1524. Obedience. *What is Obedience?* It is compliance with everything that is required by authority—it is the mainspring, the very soul and essence of all military duty. It is said a famous general once remarked every soldier should know three things—"First, *obedience*; second, *obedience*; third, *obedience*."

Cheerful, earnest and loyal obedience must be paid by all subordinates to the orders of their superiors.

A soldier should obey first and if aggrieved complain afterward.

All duty should be performed cheerfully and willingly. Soldiers are sometimes required to perform duties that are not pleasant—for instance, doing guard duty on a cold, rainy night, when tired and sleepy; digging ditches or cleaning up dirt and filth that have accumulated around the barracks, kitchens, quarters, etc., scrubbing floors, polishing stoves, cleaning knives, forks, pots, etc. However, by doing everything required of him in a cheerful manner, a soldier will soon earn the respect of his comrades and the commendation of his officers.

1525. Respect and Obedience to Noncommissioned Officers. In the orders and directions that they give, company noncommissioned officers represent the company commander, and they must be obeyed and respected at all times and under all circumstances.

Orders and regulations require that men respect and obey their noncommissioned officers, and discipline makes it imperative that they do so.

It is not for a private to question in any way the fairness, justice, propriety or wisdom of an order received from a noncommissioned officer. When ordered by a noncommissioned officer to do a thing, whatever it may be, do it promptly and thoroughly, and then if you feel that you have been injured in any way, report the matter to your company commander, who will see that you receive

justice. If the noncommissioned officer made a mistake, exceeded his authority, or treated you unfairly, he will be punished by the company commander. The company commander, and not the privates of the company, is to judge the conduct of his noncommissioned officers, who are directly responsible to him for every act of theirs.

If every subordinate were to question the fairness, justice, propriety or wisdom of orders received from noncommissioned officers or other superiors, there would be no discipline, and the Army would soon degenerate into a mob.

Remember, a soldier is supposed to obey *first*, and, if aggrieved, complain *afterward*.

[Pg 552]

And remember, too, that the authority of noncommissioned officers is not confined to the drill ground, the barracks and the post or camp. Whether you are on pass, in a theatre, in a streetcar, on a train on the street or anywhere else, if you receive an order from a noncommissioned officer you are to obey it just the same as if it were given you at drill or in barracks.

1526. Forms of Speech. In speaking to an officer it is not proper for a soldier to say, "You, etc.," but the third person should always be used, as, for example, "*Does the captain want his horse this morning?*"—do not say, "Do you want your horse this morning?" "The lieutenant is wanted on the 'phone,"—not "You are wanted on the 'phone."

In beginning a conversation with an officer, a soldier should use the third person in referring to himself instead of the pronouns "I" and "me." However, after the conversation has commenced, it is perfectly proper, and usual, for the soldier to use the pronouns "I" and "me," but an officer is *always* addressed in the third person and never as "you."

In speaking to an officer, an enlisted man should refer to another enlisted man by proper title, as, "*Sergeant Richards*," "*Corporal Smith*," "*Private Wilson*."

Privates and others should always address noncommissioned officers by their titles. For example, "*Sergeant Smith*," "*Corporal Jones*," etc., and not "*Smith*," "*Jones*," etc.

When asked his name, a soldier should answer, for instance, "*Private Jones, Sir*."

When given an order or instructions of any kind by an officer, or noncommissioned officer, a soldier should always say, "*Yes, sir*," thus letting the officer or noncommissioned officer know that the soldier understands the order or instructions. Don't say, "Very well, sir," or "All right, sir"; say, "*Yes, sir*," it's the direct, military way of answering.

Short direct answers should be made in the form of, "*No, sir*," "*Yes, sir*," "*I don't know, sir*," "*I will try, sir*," etc.

Do not use slang in speaking to an officer.

Never interrupt an officer while he is speaking. Always wait until he is through talking before you begin to speak.

After a soldier has finished a thing that he was ordered to do, he should always report to the officer who gave him the order. For example, "The captain's message to Lieutenant Smith has been delivered."

If ordered to report to an officer for any purpose, do not go away without first ascertaining if the officer is through with you, as it often happens he has something else he would like to have you do. After having finished the work given in the beginning, report, for instance, "*Sir, is the captain through with me?*"

When an officer calls a soldier who is some distance away, the soldier should immediately salute, and say, "*Yes, sir*," and, if necessary, approach the officer with a quickened step. If the officer is waiting on the soldier, the latter should take up the double time.

Always salute an officer when he leaves you after a conversation or at any other time. And always salute just as soon as the officer makes the first move to leave. Don't wait until he has moved away several feet before saluting.

[Pg 553]

Miscellaneous

1527. How to Enter an Office. In entering an office a soldier should give two or three knocks at the door (whether it be open or closed); when told to come in, enter, taking off the hat (if unarmed), close the door (if it was closed before you entered) and remain just inside the door until asked what is wanted; then go within a short distance of the officer, stand at attention, salute, and make known your request in as few words as possible. On completion, salute, face toward the door, and go out, being careful to close the door if it was closed when you entered. If it was not closed, leave it open.

1528. Complaints to the Captain. Complaints must never be made directly to the captain unless the soldier has the captain's permission to do so, or the first sergeant refuses to have the matter reported. If dissatisfied with his food, clothing, duties, or treatment, the facts should be

reported to the first sergeant, with the request, if necessary, to see the captain.

It is also customary for soldiers who wish to speak to the captain about anything to see the first sergeant first, and when speaking to the captain to inform him that they have the first sergeant's permission to do so. Thus: "Private Smith has the first sergeant's permission to speak to the captain," etc.

1529. How the Soldier is Paid. When your name is called, answer "Here," step forward and halt directly in front of the paymaster, who will be directly behind the table; salute him. When he spreads out your pay on the table in front of you, count it quickly, take it up with your ungloved hand, execute a left or right face and leave the room and building, unless you wish to deposit, in which case, you will remain in the hall outside the payroom, until the company has been paid, when you enter the payroom. Men wishing to deposit money with the paymaster, will always notify the first sergeant before the company is marched to the pay table.

1530. Delivery of Messages. When an enlisted man receives a message, verbal or written, from an officer for delivery, he will, in case he does not understand his instructions, ask the officer to repeat them, saying, for instance, "Sir, Private Smith does not understand; will the captain please repeat?" When he has received his instructions, and understands them, he will salute, and say: "Yes, sir," execute an about face, and proceed immediately to the officer for whom the message is intended. He will halt three or four paces directly in front of the officer and *if the officer be junior to the officer sending the message*, he will say, "Sir, Captain Smith presents his compliments," etc., and then deliver the message, or "The commanding officer presents his compliments to Lieutenant Smith and would like to see him at headquarters." He will salute immediately before he begins to address the officer and will hold his hand at the position of salute while he says, "Sir, Captain Smith presents his compliments," or "The commanding officer presents his compliments to Lieutenant Smith." If the officer sending the message be junior to the one receiving it, the soldier will not present his compliments, but will say, for instance, "Sir, Lieutenant Smith directed me to hand this letter to the captain," or "Sir, Lieutenant Smith directed me to say to the captain," etc. As soon as the message has been delivered, the soldier will salute, execute an about face, and proceed at once to the officer who sent the message, and will similarly report to him, "Sir, the lieutenant's message to Captain Smith has been delivered," and leave.

[Pg 554]

Before leaving an officer to whom you deliver a message always ascertain whether there is an answer.

The compliments of a junior are never presented to a senior. For instance, never say to a captain that a lieutenant presents his compliments to him.

1531. Appearance as Witness. The uniform is that prescribed. Proceed to the courtroom and remain outside. When you are notified that you are wanted enter the room. Then take off your cap and right hand glove, and raise your right hand above your head, palm to the front, to be sworn. After the judge-advocate reads the oath, say, "I do" or "So help me God." Then sit down in the chair indicated by the judge-advocate. Do not cross your legs, but sit upright. When asked, "Do you know the accused? If, so, state who he is," answer, "I do; Corporal John Jones, Co. 'B' 1st Infantry." Be sure you thoroughly understand every question before you start to reply, answering them all promptly, in a loud, distinct, deliberate voice, and confining your answers strictly to the questions asked and telling all you know.

When the judge-advocate says, "That is all," arise, salute him, execute an about face, and leave the room.

CHAPTER II

[Pg 555]

MILITARY COURTESY



1532. Its importance. Some soldiers do not see the necessity for saluting, standing at attention, and other forms of courtesy, because they do not understand their significance—their object. It is a well-known fact that military courtesy is a very important part of the education of the soldier, and there are good reasons for it.

General Orders No. 183, Division of the Philippines, 1901, says: "In all armies the manner in which military courtesies are observed and rendered by officers and soldiers, is the index to the manner in which other duties are performed."

The Army Regulations tells us, "Courtesy among military men is indispensable to discipline; respect to superiors will not be confined to obedience on duty, but will be extended on all occasions."

THE NATURE OF SALUTES AND THEIR ORIGIN

The Civilian Salute

1533. When a gentleman raises his hat to a lady he is but continuing a custom that had its beginning in the days of knighthood, when every knight wore his helmet as a protection against foes. However, when coming among friends, especially ladies, the knight would remove his helmet as a mark of confidence and trust in his friends. In those days failure to remove the helmet in the presence of ladies signified distrust and want of confidence—today it signifies impoliteness and a want of good breeding.

The Military Salute

1534. From time immemorial subordinates have always uncovered before superiors, and equals have always acknowledged each other's presence by some courtesy—this seems to be one of the natural, nobler instincts of man. It was not so many years ago when a sentinel saluted not only with his gun but by taking off his hat also. However, when complicated headgear like the bearskin and the helmet came into use, they could not be readily removed and the act of removing the hat was finally conventionalized into the present salute—into the movement of the hand to the visor as if the hat were going to be removed.

[Pg 556]

Every once in a while a man is found who has the mistaken idea that he smothers the American spirit of freedom, that he sacrifices his independence, by saluting his officers. Of course, no one but an anarchist or a man with a small, shrivelled-up mind can have such ideas.

Manly deference to superiors, which in military life is merely recognition of constituted authority, does not imply admission of inferiority any more than respect for law implies cowardice.

The recruit should at once rid himself of the idea that saluting and other forms of military courtesy are un-American. The salute is the soldier's claim from the very highest in the land to instant recognition as a soldier. The raw recruit by his simple act of saluting, commands like honor from the ranking general of the Army—aye, from even the President of the United States.

While the personal element naturally enters into the salute to a certain extent, when a soldier salutes an officer he is really saluting the office rather than the officer personally—the salute is rendered as a mark of respect to the rank, the position that the officer holds, to the authority with which he is vested. A man with the true soldierly instinct never misses an opportunity to salute his officers.

As a matter of fact, military courtesy is just simply an application of common, every-day courtesy and common sense. In common, every-day courtesy no man with the instincts of a gentleman ever thinks about taking advantage of this thing and that thing in order to avoid paying to his fellow-man the ordinary, conventional courtesies of life, and if there is ever any doubt about the matter, he takes no chances but extends the courtesy. And this is just exactly what the man who has the instincts of a real soldier does in the case of military courtesy. The thought of "Should I salute or should I not salute" never enters the mind of a soldier just because he happens to be in a wagon, in a postoffice, etc.

In all armies of the world, all officers and soldiers are required to salute each other whenever they meet or pass, the subordinate saluting first. The salute on the part of the subordinate is not intended in any way as an act of degradation or a mark of inferiority, but is simply a military courtesy that is as binding on the officer as it is on the private, and just as the enlisted man is required to salute the officer first, so is the officer required to salute his superiors first. It is a bond uniting all in a common profession, marking the fact that above them there is an authority that both recognize and obey—the Country! Indeed, by custom and regulations, it is as obligatory for the ranking general of the Army to return the salute of the recruit, as it is for the latter to give it.

Let it be remembered that the military salute is a form of greeting that belongs exclusively to the Government—to the soldier, the sailor, the marine—it is the mark and prerogative of the military man and he should be proud of having the privilege of using that form of salutation—a form of salutation that marks him as a member of the Profession of Arms—the profession of Napoleon, Wellington, Grant, Lee, Sherman, Jackson and scores of others of the greatest and most famous men the world has ever known. The military salute is ours, it is ours only. Moreover, it belongs only to the soldier who is in good standing, the prisoner under guard, for instance, not being allowed to salute. Ours is a grand fraternity of men-at-arms, banded together for national defense, for the maintenance of law and order—we are bound together by the love and respect we bear the flag—we are pledged to loyalty, to one God, one country—our lives are dedicated to the defense of our country's flag—the officer and the private belong to a brotherhood whose regalia is the uniform of the American soldier, and they are known to one another and to all men, by an honored sign and symbol of knighthood that has come down to us from the ages—THE MILITARY SALUTE!

[Pg 557]

WHOM TO SALUTE

1535. Army officers. All Army officers are saluted by their juniors and by enlisted men.

1536. Navy, Marine Corps, Volunteer and National Guard officers. Soldiers at all times and in all situations salute officers of the Navy, Marine Corps, and National Guard the same as they salute officers of the Regular Army.

1537. Reserve Corps officers. Although the subject is not at present (March, 1917) covered by orders or regulations, it goes without saying that soldiers would salute members of the Officers' Reserve Corps *on active duty* the same as they salute their own officers.

1538. Foreign naval and military officers. The Manual of Interior Guard Duty requires sentinels to salute foreign naval and military officers, but there are no instructions about other enlisted men saluting them. However, as an act of international courtesy, they should be saluted the same as our own officers.

WHEN AND HOW TO SALUTE

1539. General rule. Day or night, covered or uncovered, whether either or both are in uniform or civilian clothes, salutes shall be exchanged between officers and enlisted men not in a military formation, nor at drill, work, games or mess, on every occasion of their meeting, passing near or being addressed, the junior in rank or the enlisted man saluting first.

1540. Saluting when making and receiving reports. When making or receiving official reports, or on meeting out of doors, all officers will salute.

Military courtesy requires the junior to salute first, but when the salute is introductory to a report made at a military ceremony or formation, to the representative of a common superior (as, for example, to the adjutant, officer of the day, etc.), the officer making the report, whatever his rank, will salute first; the officer to whom the report is made will acknowledge by saluting that he has received and understood the report.

1541. Saluting distance. Saluting distance is that within which recognition is easy. In general, it does not exceed 30 paces.

As to the distance at which the salute should be made, the following is what has been the practice in the Army:

In approaching or passing each other within saluting distance, individuals or bodies of troops exchange salutes when at a distance of about 6 paces. If they do not approach each other that closely, the salute is exchanged at the point of nearest approach. For instance, if the officer and soldier are approaching each other on the same sidewalk, the hand is brought up to the headdress when about 6 paces from the officer. If they are on opposite sides of the street, the hand is brought up when about ten paces in advance of the officer. If the officer and soldier are not going in opposite directions and the officer does not approach within six paces, the salute is rendered when the officer reaches the nearest point to the soldier. If a soldier passes an officer from the rear, the hand is raised as he reaches the officer; if an officer passes a soldier from the rear, the soldier salutes just as the officer is about to pass him.

[Pg 558]

1542. Officer entering room occupied by soldiers. When an officer enters a room where there are several enlisted men, the word "attention" is given by someone who perceives him, when all rise, uncover, and remain standing at attention until the officer leaves the room or directs otherwise.

1543. At meals. Enlisted men at meals stop eating and remain seated at attention when an officer enters the room.

1544. When seated. An enlisted man, if seated, rises on the approach of an officer, faces toward him, stands at attention, and salutes. Standing he faces an officer for the same purpose. If the parties remain in the same place or on the same ground, such compliments need not be repeated.

1545. Soldier indoors. Indoors, an unarmed enlisted man uncovers and stands at attention upon the approach of an officer. If armed with rifle, he renders the rifle salute at the order or trail.

(Note. According to custom, the term "indoors" is interpreted as meaning military offices barracks, quarters and similar places,—it does not mean such public places as stores, storehouses, riding halls, stables, post exchange buildings, hotels, places of amusement, and railway and steamboat stations. In such places an unarmed soldier renders the right hand salute.)

1546. Officers approaching number of soldiers in open. When an officer approaches a number of enlisted men out of doors, the word "attention" should be given by someone who perceives him, when all stand at attention and all salute. It is customary for all to salute at or about the same instant, taking the time from the soldier nearest the officer, and who salutes when the officer is six paces from him.

1547. At work. Soldiers actually at work do not cease work to salute an officer unless addressed by him.

1548. Riding in wagon. A soldier riding in a wagon should salute officers that he passes. He would salute without rising. Likewise, a soldier driving a wagon should salute, unless both hands are occupied.

1549. Passing officer on staircase. It is customary for a soldier who is passed by an officer on a staircase to come to a halt and stand at attention.

1550. Addressing or being addressed by an officer. Before addressing an officer, or when addressed by an officer, an enlisted man makes the prescribed salute with the weapon with which he is armed; or, if unarmed, with the right hand. He also makes the same salute after receiving a reply.

[Pg 559]

1551. How salutes are rendered in uniform. In uniform, covered or uncovered, but not in formation, officers and enlisted men salute military persons as follows: With arms in hand, the salute prescribed for that arm (sentinels on interior guard duty excepted); without arms, the right-hand salute.

1552. Rifle salute. Enlisted men out of doors and armed with the rifle, salute with the piece at the right shoulder; if indoors, the rifle salute is rendered at the order or trail.

1553. Saber salute. An enlisted man armed with the saber renders the saber salute, if the saber is drawn; otherwise he salutes with the hand.

1554. Sentinels on post. A soldier salutes with the "present arms" only when actually on post as a sentinel doing interior guard duty. At all other times when armed with the rifle he salutes with the prescribed rifle salute.

The general rules and principles of saluting apply to sentinels on post doing interior guard duty, except, as just stated, they salute by presenting arms when armed with the rifle. However, they do not salute if it interferes with the proper performance of their duties.

1555. How salutes are rendered in civilian dress. In civilian dress, covered or uncovered, officers and enlisted men salute military persons with the right-hand salute.

1556. Saluting in military manner. Officers and enlisted men will render the prescribed salutes in a military manner.

1557. Several officers together. When several officers in company are saluted, all entitled to the salute shall return it.

1558. Dismounting before addressing superior not mounted. Except in the field under campaign or simulated campaign conditions, a mounted officer or soldier dismounts before addressing a superior officer not mounted.

1559. Man addressed in formation. A man in formation shall not salute when directly addressed, but shall come to attention if at rest or at ease.

1560. In public places and conveyances. In public conveyances, such as railway trains and street cars, and in public places, such as theaters, honors and personal salutes may be omitted when palpably inappropriate or apt to disturb or annoy civilians present.

For instance, as a rule, it may be said that an enlisted man riding in a street car, or in the act of purchasing goods in a store, or eating in a restaurant, would not salute unless addressed by an officer. However, in case of a soldier occupying a seat in a crowded street or railway car, if he recognized a person standing to be an officer, it would be but an act of courtesy for him to raise, salute and offer the officer his seat.

1561. Salutes by commanders of detachments or other commands. Commanders of detachments or other commands will salute officers of grades higher than the person commanding the unit, by first bringing the unit to attention and then saluting as prescribed,—that is, with arms in hand, the salute prescribed for that arm; without arms in hand, the right-hand salute.

1562. Officer passing in rear of troops. When an officer entitled to the salute passes in rear of a body of troops, the troops are brought to attention when he is opposite the post of the commander.

[Pg 560]

1563. Bringing command to present arms or sabers before commander salutes. If the command is in line at a halt (not in the field) and armed with the rifle, or with sabers drawn, it shall be brought to *present arms* or *present sabers* before its commander salutes in the following cases: When the National Anthem is played, or when *to the color* or *to the standard* is sounded during ceremonies, or when a person is saluted who is its immediate or higher commander or a general officer, or when the national or regimental color is saluted.

1564. No compliments paid at drill, on march, etc. Salutes and honors, as a rule, are not paid by troops actually engaged in drill, on the march, or in the field under campaign or simulated campaign conditions. Troops on the service of security pay no compliments whatever.

1565. No saluting at double time, trot or gallop. Salutes are not rendered when marching in double time or at the trot or gallop. The soldier must first come to quick time or walk before saluting.

The question of gait applies to the person saluting and not to the one saluted,—so, a soldier would salute an officer passing in double time or at a trot or gallop.

MISCELLANEOUS

1566. Soldier walking with officer. A soldier accompanying an officer walks on the officer's left and about one pace to his rear.

1567. Prisoners do not salute. Prisoners do not salute officers. They merely stand at attention. In some commands it is customary for paroled prisoners and others who are not under the immediate charge of sentinels, to fold their arms when passing or addressing officers.

1568. Unmilitary salutes. It is very unmilitary to salute with the coat unbuttoned or with the hand in the pocket, or a cigarette, cigar or pipe in the mouth.

1569. Headdress not raised in saluting. The headdress must not be raised to ladies, but they must be given the military salute.

(War Dept. decision. August, 1913.)

1570. Caution. In saluting, the hand or weapon is held in the position of salute until the salute has been acknowledged or until the officer has passed or has been passed.

USUAL MISTAKES IN SALUTING

1571. The following are the mistakes usually made by soldiers in rendering salutes:

1. They do not begin the salute soon enough; often they do not raise the hand to the headdress until they are only a pace or two from the officer—the salute should always begin when at least six paces from the officer.

2. They do not turn the head and eyes toward the officer who is saluted—the head and eyes should always be turned toward the officer saluted and kept turned as long as the hand is raised.

3. The hand is not kept to the headdress until the salute is acknowledged by the officer—the hand should always be kept raised until the salute has been acknowledged, or it is evident the officer has not seen the saluter.

[Pg 561]

4. The salute is often rendered in an indifferent, lax manner—the salute should always be rendered with life, snap and vim; the soldier should always render a salute as if he *meant it*.

RESPECT TO BE PAID THE NATIONAL ANTHEM, THE COLORS AND STANDARDS

1572. The National Anthem. Whenever the National Anthem is played at any place when persons belonging to the military service are present, all officers and enlisted men not in formation shall stand at attention facing toward the music (except at retreat when they shall face toward the flag). If in uniform, covered or uncovered, or in civilian clothes, uncovered, they shall salute at the first note of the Anthem, retaining the position of salute until the last note of the Anthem. If not in uniform and covered, they shall uncover at the first note of the Anthem, holding the headdress opposite the left shoulder and so remain until its close, except that in inclement weather the headdress may be held slightly raised.

The same rules apply when "To the Color" or "To the Standard" is sounded as when the National Anthem is played.

1573. National anthems of other nations. The same marks of respect prescribed for observance during the playing of the National Anthem of the United States shall be shown toward the national anthem of any other country when played upon official occasions.

1574. At retreat. The flag will be lowered at the sounding of the last note of the retreat, and while the flag is being lowered the band will play the National Anthem, or, if there be no band present, the field music will sound "To the Color." When "To the Color" is sounded by the field music while the flag is being lowered the same respect will be observed as when the National Anthem is played by the band, and in either case officers and enlisted men out of ranks will face toward the flag, stand at attention, and render the prescribed salute.

1575. Colors and standards. Officers and enlisted men passing the uncased color (or standard) will render honors as follows: If in uniform they will salute as described in [par. 1551](#); if in civilian dress and covered, they will uncover, holding the headdress opposite the left shoulder with the right hand; if uncovered, they will salute with the right-hand salute.

By "Colors" and "Standards" is meant the national flags and the regimental flags that are carried by regiments and separate battalions. The national flag may be of either silk or bunting; the regimental flag is always of silk. In the Army Regulations the word "Color" is used in referring to regiments of Infantry, the Coast Artillery and battalions of Philippine Scouts, while "Standard" is used in reference to regiments of Cavalry and Field Artillery.

By *uncased* colors and standards are meant colors and standards when not in their waterproof cases.

By Flag is meant the national emblem that waves from flag staffs and other stationary poles. They are always of bunting.

PART VII

[Pg 562]

GUARD DUTY

[Pg 563]

(To include Changes No. 1, February 24, 1915.)

(The numbers following the paragraphs are those of the *Manual of Interior Guard Duty*.)

1576. Importance. Guard duty is one of the soldier's most important duties, and in all armies of the world the manner in which it is performed is an index to the discipline of the command and the manner in which other duties are performed.

Upon the guard's vigilance and readiness for action depend not only the enforcement of military law and orders, but also the safety and protection of the post and the quelling of sudden disorder, perhaps even mutiny.

The importance of guard duty is increased during times of war, when the very safety of the army depends upon the vigilance of the sentinels, who are required to watch that others may sleep and thus refresh themselves from the labors of the day. The sentinels are the guardians of the repose, quiet and safety of the camp.

1577. Respect for Sentinels. Respect for the person and office of a sentinel is as strictly enjoined by military law as that required to be paid to an officer. As it is expressed in the *Manual of Guard Duty*, "All persons of whatever rank in the service are required to observe respect toward sentinels." Invested as the private soldier frequently is, while on his post, with a grave responsibility, it is proper that he should be fully protected in the discharge of his duty. To permit anyone, of whatever rank, to molest or interfere with him while thus employed, without becoming liable to severe penalty, would clearly establish a precedent highly prejudicial to the interests of the service. (*Davis' Military Law*).

1578. Duty of sentinels. A sentinel, in respect to the duties with which he is charged, represents the superior military authority of the command to which he belongs, and whose orders he is required to enforce on or in the vicinity of his post. As such he is entitled to the respect and obedience of all persons who come within the scope of operation of the orders, which he is required to carry into effect. Over military persons the authority of the sentinel is absolute, and disobedience of his orders on the part of such persons constitutes a most serious military offence and is prejudicial in the highest degree to the interests of discipline. (*Davis' Military Law*).—
Author.

INTRODUCTION

1579. Guards may be divided into four classes: Exterior guards, interior guards, military police, and provost guards. (1)

1580. Exterior guards are used only in time of war. They belong to the domain of tactics and are treated of in the *Field Service Regulations* and in the drill regulations of the different arms of the service.

The purpose of exterior guards is to prevent surprise, to delay attack, and otherwise to provide for the security of the main body.

[Pg 564]

On the march they take the form of advance guards, rear guards, and flank guards. At a halt they consist of outposts. (2)

1581. Interior guards are used in camp or garrison to preserve order, protect property, and to enforce police regulations. In time of war such sentinels of an interior guard as may be necessary are placed close in or about a camp, and normally there is an exterior guard further out consisting of outposts. In time of peace the interior guard is the only guard in a camp or garrison.

(3)

1582. Military police differ somewhat from either of these classes. (See *Field Service Regulations*.) They are used in time of war to guard prisoners, to arrest stragglers and deserters, and to maintain order and enforce police regulations in the rear of armies, along lines of communication, and in the vicinity of large camps. (4)

1583. Provost guards are used in the absence of military police, generally in conjunction with the civil authorities at or near large posts or encampments, to preserve order among soldiers beyond the interior guard. (5)

INTERIOR GUARD

Classification

1584. The various elements of an interior guard classified according to their particular purposes and the manner in which they perform their duties are as follows:

(a) The main guard.

(b) Special guards: Stable guards, park guards, prisoner guards, herd guards, train guards, boat guards, watchmen, etc. (6)

Details and Rosters

1585. At every military post, and in every regiment or separate command in the field, an interior guard will be detailed and duly mounted.

It will consist of such number of officers and enlisted men as the commanding officer may deem necessary, and will be commanded by the senior officer or noncommissioned officer therewith, under the supervision of the officer of the day or other officer detailed by the commanding officer. (7)

1586. The system of sentinels on fixed posts is of value in discipline and training because of the direct individual responsibility which is imposed and required to be discharged in a definite and precise manner. In order, however, that guard duty may not be needlessly irksome and interfere with tactical instruction, the number of men detailed for guard will be the smallest possible.

Commanding officers are specifically charged with this matter, and, without entirely dispensing with the system of sentinels on fixed posts will, as far as practicable in time of peace, replace such sentinels with watchmen. (See [Par. 1781.](#)) (8)

1587. At posts where there are less than three companies the main guard and special guards may all be furnished by one company or by detail from each company.

Where there are three or more companies, the main guard will, if practicable, be furnished by a single company, and, as far as practicable, the same organization will supply all details for that day for special guard, overseer, and fatigue duty. In this case the officer of the day, and the officers of the guard, if there are any, will, if practicable, be from the company furnishing the guard. (9)

[Pg 565]

1588. There will be an officer of the day with each guard, unless in the opinion of the commanding officer the guard is so small that his services are not needed. In this case an officer will be detailed to supervise the command and instruction of the guard for such period as the commanding officer may direct. (16)

1589. The detail of officers of the guard will be limited to the necessities of the service and efficient instruction; inexperienced officers may be detailed as supernumerary officers of the guard for purposes of instruction. (18).

1590. The strength of guards and the number of consecutive days for which an organization furnishes the guard will be so regulated as to insure privates of the main guard an interval of not less than five days between tours.

The Commanding Officer

1591. The commanding officer will exact a faithful, vigilant, and correct performance of guard duty in all of its details, giving his orders to the officer of the day, or causing them to be communicated to him with the least practicable delay. He will prescribe the strength of the guard, and the necessary regulations for guard, police, and fatigue duty. (27)

1592. The commanding officer receives the reports of the officers of the day immediately after guard mounting, at his office, or at some other place previously designated; carefully examines

the guard report and remarks thereon (questioning the old officer of the day, if necessary, concerning his tour of duty), relieves the old officer of the day and gives the new officer of the day such instructions as may be necessary. (28)

The Officer of the Day

1593. The officer of the day is responsible for the proper performance of duty by the guard with which he marches on and for the enforcement of all police regulations. He is charged with the execution of all orders of the commanding officer relating to the safety and good order of the post or camp. His actual tour begins when he receives the instructions of the commanding officer after guard mounting, and ceases when he has been relieved by the commanding officer. In case of emergency during the interval between guard mounting and reporting to the commanding officer, the senior officer of the day will give the necessary instructions for both guards. (29)

1594. In the absence of special instructions from the commanding officer, the officer of the day will inspect the guard and sentinels during the day and at night at such times as he may deem necessary. He will visit them at least once between 12 o'clock midnight and daylight. (30)

He may prescribe patrols ([Par. 1778](#)) and visits of inspection to be made by officers and noncommissioned officers of the guard whenever he deems it necessary. (31)

[Pg 566]

1595. He will see that the commander of the guard is furnished with the parole and countersign before retreat in case they are to be used, and will inform him of the presence in post or camp of any person entitled to the compliment. (32)

1596. In case of alarm of any kind he will at once take such steps as may be necessary to insure the safety of life and public property and to preserve order in the command, disposing his guard so as best to accomplish this result. (33)

1597. In the performance of his duties as officer of the day he is subject to the orders of the commanding officer only, except that in case of an alarm of any kind, and at a time of great danger, the senior line officer present is competent to give necessary orders to the officer of the day for the employment of the guard. (34)

1598. At the inspection and musters prescribed in *Army Regulations*, the officer of the day will be present at the post of the guard, but all commands to the guard will be given by the commander of the guard. (35)

Both officers of the day together verify the prisoners and inspect the guardhouse and premises. (36)

1599. In the absence of special instructions, the old officer of the day will, at guard mounting, release all garrison prisoners whose sentences expire that day. If there are any prisoners with no record of charges against them, the old officer of the day will report that fact to the commanding officer who will give the necessary instructions. (37)

1600. The old officer of the day signs the report of the commander of the guard. He also enters on it such remarks as may be necessary. (38)

1601. The officers of the day then report to the commanding officer.

On presenting themselves, both salute with the right hand, remaining covered. The old officer of the day, standing on the right of the new, then says: "**Sir, I report as old officer of the day,**" and presents the guard report. As soon as the commanding officer notifies the old officer of the day that he is relieved, the old officer of the day salutes the commanding officer and retires. The new officer of the day again salutes and says: "**Sir, I report as new officer of the day,**" and then receives his instructions. (39)

1602. The officer of the day will always keep the guard informed as to where he may be found at all hours of the day and night. (40)

Commander of the Guard

1603. The commander of the guard is responsible for the instruction and discipline of the guard. He will see that all of its members are correctly instructed in their orders and duties, and that they understand and properly perform them. He will visit each relief at least once while it is on post, and at least one of these visits will be made between 12 o'clock midnight and daylight. (41)

1604. He receives and obeys the orders of the commanding officer and the officer of the day, and reports to the latter without delay all orders to the guard not received from the officer of the day; he transmits to his successor all material instructions and information relating to his duties. (42)

[Pg 567]

1605. He is responsible under the officer of the day for the general safety of the post or camp as soon as the old guard marches away from the guardhouse. In case of emergency while both

guards are at the guardhouse, the senior commander of the two guards will be responsible that the proper action is taken. (43)

1606. Officers of the guard will remain constantly with their guards, except while visiting patrols or necessarily engaged elsewhere in the performance of their duties. The commanding officer will allow a reasonable time for meals. (44)

1607. A commander of a guard leaving his post for any purpose will inform the next in command of his destination and probable time of return. (45)

1608. Except in emergencies, the commander of the guard may divide the night with the next in command, but retains his responsibility; the one on watch must be constantly on the alert. (46)

1609. When any alarm is raised in camp or garrison, the guard will be formed immediately. ([Par. 1793.](#)) If the case be serious, the proper call will be sounded, and the commander of the guard will cause the commanding officer and the officer of the day to be at once notified. (47)

1610. If a sentinel calls: "**The Guard,**" the commander of the guard will at once send a patrol to the sentinel's post. If the danger be great, in which case the sentinel will discharge his piece, the patrol will be as strong as possible. (48)

1611. When practicable, there should always be an officer or noncommissioned officer and two privates of the guard at the guardhouse, in addition to the sentinels there on post. (49)

1612. Between reveille and retreat, when the guard had been turned out for any person entitled to the compliment (See [Pars. 1782](#) and [1784](#)), the commander of the guard, if an officer, will receive the report of the sergeant, returning the salute of the later with the right hand. He will then draw his saber, and place himself two paces in front of the center of the guard. When the person for whom the guard has been turned out approaches, he faces his guard and commands: **1. Present, 2. ARMS**; faces to the front and salutes. When his salute is acknowledged he resumes the carry, faces about, and commands: **1. Order, 2. ARMS**; and faces to the front.

If it be an officer entitled to inspect the guard, after saluting and before bringing his guard to an order, the officer of the guard reports: "**Sir, all present or accounted for**"; or, "**Sir, (so and so) is absent**"; or, if the roll call has been omitted: "**Sir, the guard is formed,**" except that at guard mounting the commanders of the guards present their guards and salute without making any report.

Between retreat and reveille, the commander of the guard salutes and reports, but does not bring the guard to a present. (50)

1613. To those entitled to have the guard turned out but not entitled to inspect it, no report will be made; nor will a report be made to any officer, unless he halts in front of the guard. (51)

1614. When a guard commanded by a noncommissioned officer is turned out as a compliment or for inspection, the noncommissioned officer, standing at a right shoulder on the right of the right guide, commands: **1. Present, 2. ARMS.** He then executes the rifle salute. If a report be also required, he will, after saluting, and before bringing his guard to an order, report as prescribed for the officer of the guard. ([Par. 1612.](#)) (52)

[Pg 568]

1615. When a guard is in line, not under inspection, and commanded by an officer, the commander of the guard salutes his regimental, battalion, and company commander, by bringing the guard to attention and saluting in person.

For all other officers, excepting those entitled to the compliment from a guard ([Par. 1784](#)), the commander of the guard salutes in person, but does not bring the guard to attention.

When commanded by a noncommissioned officer the guard is brought to attention in either case, and the noncommissioned officer salutes.

The commander of a guard exchanges salutes with the commanders of all other bodies of troops; the guard is brought to attention during the exchange.

"**Present arms**" is executed by a guard only when it has turned out for inspection or as a compliment, and at the ceremonies of guard mounting and relieving the old guard. (53)

1616. In marching a guard or a detachment of a guard the principles of [paragraph 1615](#) apply. "**Eyes right**" is executed only in the ceremonies of guard mounting and relieving the old guard. (54)

1617. If a person entitled to the compliment, or the regimental, battalion, or company commander, passes in rear of a guard, neither the compliment nor the salute is given, but the guard is brought to attention while such person is opposite the post of the commander.

After any person has received or declined the compliment, or received the salute from the commander of the guard, official recognition of his presence thereafter while he remains in the vicinity will be taken by bringing the guard to attention. (55)

1618. The commander of the guard will inspect the guard at reveille and retreat, and at such other times as may be necessary, to assure himself that the men are in proper condition to perform their duties and that their arms and equipments are in proper condition. For inspection by other officers, he prepares the guard in each case as directed by the inspecting officer. (56)

1619. The guard will not be paraded during ceremonies unless directed by the commanding officer. (57)

1620. At all formations members of the guard or reliefs will execute inspection arms as prescribed in the drill regulations of their arm. (58)

1621. The commander of the guard will see that all sentinels are habitually relieved every two hours, unless the weather or other cause makes it necessary that it be done at shorter or longer intervals, as directed by the commanding officer. (59)

1622. He will question his noncommissioned officers and sentinels relative to the instructions they may have received from the old guard; he will see that patrols and visits of inspection are made as directed by the officer of the day. (60)

[Pg 569]

1623. He will see that the special orders for each post and member of the guard, either written or printed, are posted in the guardhouse, and, if practicable, in the sentry box or other sheltered place to which the member of the guard has constant access. (61)

1624. He will see that the proper calls are sounded at the hours appointed by the commanding officer. (62)

1625. Should a member of the guard be taken sick, or be arrested, or desert, or leave his guard, he will at once notify the officer of the day. (63)

1626. He will, when the countersign is used ([Pars. 1770](#) to 1776), communicate it to the noncommissioned officers of the guard and see that it is duly communicated to the sentinels before the hour for challenging; the countersign will not be given to sentinels posted at the guardhouse. (64)

1627. He will have the details for hoisting the flag at reveille, and lowering it at retreat, and for firing the reveille and retreat gun, made in time for the proper performance of these duties. (See [Pars. 1834](#), [1835](#), [1836](#), [1837](#)). He will see that the flags are kept in the best condition possible, and that they are never handled except in the proper performance of duty. (65)

1628. He may permit members of the guard while at the guardhouse to remove their headdress, overcoats, and gloves; if they leave the guardhouse for any purpose whatever he will require that they be properly equipped and armed according to the character of the service in which engaged, or as directed by the commanding officer. (66)

1629. He will enter in the guard report a report of his tour of duty, and, on the completion of his tour, will present it to the officer of the day. He will transmit with his report all passes turned in at the post of the guard. (67)

1630. Whenever a prisoner is sent to the guardhouse or guard tent for confinement, he will cause him to be searched, and will, without unnecessary delay, report the case to the officer of the day. (68)

1631. Under war conditions, if anyone is to be passed out of camp at night, he will be sent to the commander of the guard, who will have him passed beyond the sentinels. (69)

1632. The commander of the guard will detain at the guardhouse all suspicious characters or parties attempting to pass a sentinel's post without authority, reporting his action to the officer of the day, to whom persons so arrested will be sent, if necessary. (70)

1633. He will inspect the guard rooms and cells, and the irons of such prisoners as may be ironed, at least once during his tour, and at such other times as he may deem necessary. (71)

1634. He will cause the corporals of the old and new reliefs to verify together, immediately before each relief goes on post, the number of prisoners who should then properly be at the guardhouse. (72)

1635. He will see that the sentences of prisoners under his charge are executed strictly in accordance with the action of the reviewing authority. (73)

1636. When no special prisoner guard has been detailed ([Par. 1798](#)), he will, as far as practicable, assign as guards over working parties of prisoners sentinels from posts guarded at night only. (74)

[Pg 570]

1637. The commander of the guard will inspect all meals sent to the guardhouse and see that the quantity and quality of food are in accordance with regulations. (75)

1638. At guard mounting he will report to the old officer of the day all cases of prisoners whose

terms of sentence expire on that day, and also all cases of prisoners concerning whom no statement of charges has been received. (76)

1639. The commander of the guard is responsible for the security of the prisoners under the charge of his guard; he becomes responsible for them after their number has been verified and they have been turned over to the custody of his guard by the old guard or by the prisoner guard or overseers. (77)

1640. The prisoners will be verified and turned over to the new guard without parading them, unless the commanding officer or the officer of the day shall direct otherwise. (78)

1641. To receive the prisoners at the guardhouse when they have been paraded and after they have been verified by the officers of the day, the commander of the new guard directs his sergeant to form his guard with an interval, and commands: **1. Prisoners, 2. Right, 3. FACE, 4. Forward, 5. MARCH.** The prisoners having arrived opposite the interval in the new guard, he commands: **1. Prisoners, 2. HALT, 3. Left, 4. FACE, 5. Right (or left), 6. DRESS, 7. FRONT.**

The prisoners dress on the line of the new guard. (79)

Sergeant of the Guard

1642. The senior noncommissioned officer of the guard always acts as sergeant of the guard, and if there be no officer of the guard, will perform the duties prescribed for the commander of the guard. (80)

1643. The sergeant of the guard has general supervision over the other noncommissioned officers and the musicians and privates of the guard, and must be thoroughly familiar with all of their orders and duties. (81)

1644. He is directly responsible for the property under charge of the guard, and will see that it is properly cared for. He will make lists of articles taken out by working parties, and see that all such articles are duly returned. If they are not, he will immediately report the fact to the commander of the guard. (82)

1645. Immediately after guard mounting he will prepare duplicate lists of the names of all noncommissioned officers, musicians, and privates of the guard, showing the relief and post or duties of each. One list will be handed as soon as possible to the commander of the guard; the other will be retained by the sergeant. (83)

1646. He will see that all reliefs are turned out at the proper time, and that the corporals thoroughly understand, and are prompt and efficient in, the discharge of their duties. (84)

1647. During the temporary absence from the guardhouse of the sergeant of the guard, the next in rank of the noncommissioned officers will perform his duties. (85)

1648. Should the corporal whose relief is on post be called away from the guardhouse, the sergeant of the guard will designate a noncommissioned officer to take the corporal's place until his return. (86)

[Pg 571]

1649. The sergeant of the guard is responsible at all times for the proper police of the guardhouse or guard tent, including the ground about them and the prison cells. (87)

1650. At "**first sergeant's call**" he will proceed to the adjutant's office and obtain the guard report book. (88)

1651. When the national or regimental colors are taken from the stacks of the color line, the color bearer and guard, or the sergeant of the guard, unarmed, and two armed privates as a guard, will escort the colors to the colonel's quarters, as prescribed for the color guard in the drill regulations of the arm of the service to which the guard belongs. (89)

1652. He will report to the commander of the guard any suspicious or unusual occurrence that comes under his notice, will warn him of the approach of any armed body, and will send to him all persons arrested by the guard. (90)

1653. When the guard is turned out, its formation will be as follows: The senior noncommissioned officer, if commander of the guard, is on the right of the right guide; if not commander of the guard, he is in the line of file closers, in rear of the right four of the guard; the next in rank is right guide; the next left guide; the others in the line of file closers, usually, each in rear of his relief; the field music, with its left three paces to the right of the right guide. The reliefs form in the same order as when the guard was first divided, except that if the guard consists of dismounted cavalry and infantry, the cavalry forms on the left. (91)

1654. The sergeant forms the guard, calls the roll, and, if not in command of the guard, reports to the commander of the guard as prescribed in drill regulations for a first sergeant forming a

troop or company; the guard is not divided into platoons or sections, and, except when the whole guard is formed prior to marching off, fours are not counted. (92)

1655. The sergeant reports as follows: "**Sir, all present or accounted for,**" or "**Sir, (so-and-so) is absent**"; or if the roll call has been omitted, "**Sir, the guard, is formed.**" Only men absent without proper authority are reported absent. He then takes his place, without command. (93)

1656. At night, the roll may be called by reliefs and numbers instead of names; thus, the first relief being on post: **Second relief; No. 1; No. 2,** etc.; **Third relief, Corporal; No. 1,** etc. (94)

1657. Calling the roll will be dispensed with in forming the guard when it is turned out as a compliment, on the approach of an armed body, or in any sudden emergency; but in such cases the roll may be called before dismissing the guard. If the guard be turned out for an officer entitled to inspect it, the roll will, unless he directs otherwise, always be called before a report is made. (95)

1658. The sergeant of the guard has direct charge of the prisoners, except during such time as they may be under the charge of the prisoner guard or overseers, and is responsible to the commander of the guard for their security. (96)

1659. He will carry the keys of the guardroom and cells, and will not suffer them to leave his personal possession while he is at the guardhouse, except as hereinafter provided. (Par. 1661.) Should he leave the guardhouse for any purpose, he will turn the keys over to the noncommissioned officer who takes his place. (Par. 1647.) (97)

[Pg 572]

1660. He will count the knives, forks, etc., given to the prisoners with their food, and see that none of these articles remain in their possession. He will see that no forbidden articles of any kind are conveyed to the prisoners. (98)

1661. Prisoners when paraded with the guard, are placed in line in its center. The sergeant, immediately before forming the guard, will turn over his keys to the noncommissioned officer at the guardhouse. Having formed the guard, he will divide it into two nearly equal parts. Indicating the point of division with his hand, he commands:

1. Right (or left), 2. FACE, 3. Forward, 4. MARCH, 5. Guard, 6. HALT, 7. Left (or right), 8. FACE.

If the first command be **right face**, the right half of the guard only will execute the movements: if **left face**, the left half only will execute them. The command **halt** is given when sufficient interval is obtained to admit the prisoners. The doors of the guardroom and cells are then opened by the noncommissioned officer having the keys. The prisoners will file out under the supervision of the sergeant, the noncommissioned officer, and sentinel on duty at the guardhouse, and such other sentinels as may be necessary; they will form in line in the interval between the two parts of the guard. (99)

1662. To return the prisoners to the guardroom and cells, the sergeant commands:

1. Prisoners, 2. Right (or left), 3. FACE, 4. Column right (or left), 5. MARCH.

The prisoners, under the same supervision as before, return to their proper rooms or cells. (100)

1663. To close the guard, the sergeant commands:

1. Left (or right), 2. FACE, 3. Forward, 4. MARCH, 5. Guard, 6. HALT, 7. Right (or left), 8. FACE.

The left or right half only of the guard as indicated, executes the movement. (101)

1664. If there be but few prisoners, the sergeant may indicate the point of division as above, and form the necessary interval by the commands:

1. Right (or left) step, 2. MARCH, 3. Guard, 4. HALT, and close the intervals by the commands:

1. Left (or right) step, 2. MARCH, 3. Guard, 4. HALT. (102)

1665. If sentinels are numerous, reliefs may, at the discretion of the commanding officer, be posted in detachments, and sergeants, as well as corporals, required to relieve and post them. (103)

Corporal of the Guard

1666. A corporal of the guard receives and obeys orders from none but noncommissioned officers of the guard senior to himself, the officers of the guard, the officer of the day, and the

1667. It is the duty of the corporal of the guard to post and relieve sentinels, and to instruct the members of his relief in their orders and duties. (105)

1668. Immediately after the division of the guard into reliefs the corporals will assign the members of their respective reliefs to posts by number, and a soldier so assigned to his post will not be changed to another during the same tour of guard duty, unless by direction of the commander of the guard or higher authority. Usually, experienced soldiers are placed over the arms of the guard, and at remote and responsible posts. (106)

1669. Each corporal will then make a list of the members of his relief including himself. This list will contain the number of the relief, the name, the company, and the regiment of every member thereof, and the post to which each is assigned. The list will be made in duplicate, one copy to be given to the sergeant of the guard as soon as completed, the other to be retained by the corporal. (107)

1670. When directed by the commander of the guard, the corporal of the first relief forms his relief, and then commands: **CALL OFF.**

Commencing on the right, the men call off alternately **rear** and **front** rank, "**one**," "**two**," "**three**," "**four**," and so on; if in single rank, they call off from right to left. The corporal then commands:

1. Right, 2. FACE, 3. Forward, 4. MARCH.

The corporal marches on the left, and near the rear file, in order to observe the march. The corporal of the old guard marches on the right of the leading file, and takes command when the last one of the old sentinels is relieved, changing places with the corporal of the new guard. (108)

1671. When the relief arrives at six paces from a sentinel (See [Par. 1729](#)), the corporal halts it and commands, according to the number of the post: **No. (—).**

Both sentinels execute port arms or saber; the new sentinel approaches the old, halting about one pace from him. (See [Par. 1733](#).) (109)

1672. The corporals advance and place themselves, facing each other, a little in advance of the new sentinel, the old corporal on his right, the new corporal on his left, both at a right shoulder, and observe that the old sentinel transmits correctly his instructions.

The following diagram will illustrate the positions taken:

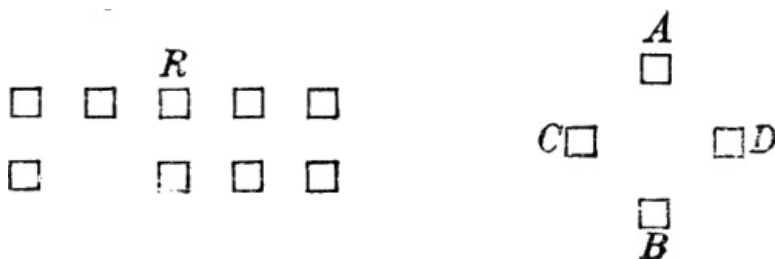

R is the relief; A, the new corporal; B, the old; C, the new sentinel; D, the old. (110)

1673. The instructions relative to the post having been communicated, the new corporal commands, **Post**; both sentinels then resume the right shoulder, face toward the new corporal and step back so as to allow the relief to pass in front of them. The new corporal then commands, **1. Forward, 2. MARCH**; the old sentinel takes his place in rear of the relief as it passes him, his piece in the same position as those of the relief. The new sentinel stands fast at a right shoulder until the relief has passed six paces beyond him, when he walks his post. The corporals take their places as the relief passes them. (111)

1674. Mounted sentinels are posted and relieved in accordance with the same principles. (112)

1675. On the return of the old relief, the corporal of the new guard falls out when the relief halts; the corporal of the old guard forms his relief on the left of the old guard, salutes, and reports to the commander of his guard: "**Sir, the relief is present**"; or "**Sir, (so and so) is absent**," and takes his place in the guard. (113)

1676. To post a relief other than that which is posted when the old guard is relieved, its corporal commands:

1. (Such) relief, 2. FALL IN; and if arms are stacked, they are taken at the proper commands.

The relief is formed facing to the front, with arms at an **order**; the men place themselves according to the numbers of their respective posts, viz., **two, four, six**, and so on, in the **front rank**, and **one, three, five**, and so on, in the **rear rank**. The corporal, standing about two paces

in front of the center of his relief, then commands: **Call off.**

The men call off as prescribed. The corporal then commands: **1. Inspection, 2. ARMS, 3. Order, 4. ARMS;** faces the commander of the guard, executes the rifle salute, reports: "**Sir, the relief is present,**" or "**Sir, (so and so) is absent**"; he then takes his place on the right at order arms. (114)

1677. When the commander of the guard directs the corporal: "**Post your relief,**" the corporal salutes and posts his relief as prescribed ([Pars. 108](#) to 111); the corporal of the relief on post does not go with the new relief, except when necessary to show the way. (115)

1678. To dismiss the old relief, it is halted and faced to the front at the guardhouse by the corporal of the new relief, who then falls out; the corporal of the old relief then steps in front of the relief and dismisses it by the proper commands. (116)

1679. Should the pieces have been loaded before the relief was posted, the corporal will, before dismissing the relief, see that no cartridges are left in the chambers or magazines. The same rule applies to sentinels over prisoners. (117)

1680. Each corporal will thoroughly acquaint himself with all the special orders of every sentinel on his relief, and see that each understands and correctly transmits such orders **in detail** to his successor. (118)

1681. There should be at least one noncommissioned officer constantly on the alert at the guardhouse, usually the corporal whose relief is on post. This noncommissioned officer takes post near the entrance of the guardhouse, and does not fall in with the guard when it is formed. He will have his rifle constantly with him. (119)

1682. Whenever it becomes necessary for the corporal to leave his post near the entrance of the guardhouse, he will notify the sergeant of the guard, who will at once take his place, or designate another noncommissioned officer to do so. (120)

[Pg 575]

1683. He will see that no person enters the guardhouse, or guard tent, or crosses the posts of the sentinels there posted without proper authority. (121)

1684. Should any sentinel call for the corporal of the guard, the corporal will, in every case, at once and quickly proceed to such sentinel. He will notify the sergeant of the guard before leaving the guardhouse. (122)

1685. He will at once report to the commander of the guard any violation of regulations or any unusual occurrence which is reported to him by a sentinel, or which comes to his notice in any other way. (123)

1686. Should a sentinel call: "**The Guard,**" the corporal will promptly notify the commander of the guard. (124)

1687. Should a sentinel call: "**Relief,**" the corporal will at once proceed to the post of such sentinel, taking with him the man next for duty on that post. If the sentinel is relieved for a short time only, the corporal will again post him as soon as the necessity for his relief ceases. (125)

1688. When the countersign is used, the corporal at the posting of the relief during whose tour challenging is to begin gives the countersign to the members of the relief, excepting those posted at the guardhouse. (126)

1689. He will wake the corporal whose relief is next on post in time for the latter to verify the prisoners, form his relief, and post it at the proper hour. (127)

1690. Should the guard be turned out, each corporal will call his own relief, and cause its members to fall in promptly. (128)

1691. Tents or bunks in the same vicinity will be designated for the reliefs so that all the members of each relief may, if necessary, be found and turned out by the corporal in the least time and with the least confusion. (129)

1692. When challenged by a sentinel while posting his relief, the corporal commands: **1. Relief, 2. HALT;** to the sentinel's challenge he answers "**Relief,**" and at the order of the sentinel he advances alone to give the countersign, or to be recognized. When the sentinel says, "**Advance relief,**" the corporal commands: **1. Forward, 2. MARCH.**

If to be relieved, the sentinel is then relieved as prescribed. (130)

1693. Between retreat and reveille, the corporal of the guard will challenge all suspicious looking persons or parties he may observe, first halting his patrol or relief, if either be with him. He will advance them in the same manner that sentinels on post advance like parties ([Pars. 1751](#) to 1757), but if the route of a patrol is on a continuous chain of sentinels, he should not challenge persons coming near him unless he has reason to believe that they have eluded the vigilance of

sentinels. (131)

1694. Between retreat and reveille, whenever so ordered by an officer entitled to inspect the guard, the corporal will call: "**Turn out the guard,**" announcing the title of the officer, and then, if not otherwise ordered he will salute and return to his post. (132)

1695. As a general rule he will advance parties approaching the guard at night in the same manner that sentinels on post advance like parties. Thus, the sentinel at the guardhouse challenges and repeats the answer to the corporal, as prescribed hereafter ([Par. 1760](#)); the corporal, advancing at "**port arms,**" says: "**Advance (so and so) with the countersign,**" or "**to be recognized,**" if there be no countersign used; the countersign being correctly given, or the party being duly recognized, the corporal says: "**Advance (so and so)**"; repeating the answer to the challenge of the sentinel. (133)

[Pg 576]

1696. When officers of different rank approach the guardhouse from different directions at the same time, the senior will be advanced first, and will not be made to wait for his junior. (134)

1697. Out of ranks and under arms, the corporal salutes with the rifle salute. He will salute all officers whether by day or night. (135)

1698. The corporal will examine parties halted and detained by sentinels, and if he has reason to believe the parties have no authority to cross sentinel's posts, will conduct them to the commander of the guard. (136)

1699. The corporal of the guard will arrest all suspicious looking characters prowling about the post or camp, all persons of a disorderly character disturbing the peace, and all persons taken in the act of committing crime against the Government on a military reservation or post. All persons arrested by corporals of the guard, or by sentinels, will at once be conducted to the commander of the guard by the corporal. (137)

Musicians of the Guard

1700. The musicians of the guard will sound call as prescribed by the commanding officer. (138)

1701. Should the guard be turned out for national or regimental colors or standards, uncased, the field music of the guard will, when the guard present arms, sound, "**To the color**" or "**To the standard**"; or, if for any person entitled thereto, the march, flourishes, or ruffles, prescribed in paragraphs 375, 376, and 377, A. R. (139)

Orderlies and Color Sentinels

1702. When so directed by the commanding officer, the officer who inspects the guard at guard mounting will select from the members of the new guard an orderly for the commanding officer and such number of other orderlies and color sentinels as may be required. (140)

For these positions the soldiers will be chosen who are most correct in the performance of duty and in military bearing, neatest in person and clothing, and whose arms and accouterments are in the best condition. Clothing, arms, and equipments must conform to regulations. If there is any doubt as to the relative qualifications of two or more soldiers, the inspecting officer will cause them to fall out at the guardhouse and to form in line in single rank. He will then, by testing them in drill regulations, select the most proficient. The commander of the guard will be notified of the selection. (141)

1703. When directed by the commander of the guard to fall out and report, an orderly will give his name, company, and regiment to the sergeant of the guard, and, leaving his rifle in the arm rack in his company quarters, will proceed at once to the officer to whom he is assigned, reporting: "**Sir, Private —, Company —, reports as orderly.**" (142)

[Pg 577]

1704. If the orderly selected be a cavalryman, he will leave his rifle in the arm rack of his troop quarters, and report with his belt on, but without side arms unless specially otherwise ordered. (143)

1705. Orderlies, while on duty as such, are subject only to the orders of the commanding officer and of the officers to whom they are ordered to report. (144)

1706. When an orderly is ordered to carry a message, he will be careful to deliver it exactly as it was given to him. (145)

1707. His tour of duty ends when he is relieved by the orderly selected from the guard relieving his own. (146)

1708. Orderlies are members of the guard, and their name, company, and regiment are entered on the guard report and lists of the guard. (147)

1709. If a color line is established, sufficient sentinels are placed on the color line to guard the colors and stacks. (148)

1710. Color sentinels are posted only so long as the stacks are formed. The commander of the guard will divide the time equally among them. (149)

1711. When stacks are broken, the color sentinels may be permitted to return to their respective companies. They are required to report in person to the commander of the guard at reveille and retreat. They will fall in with the guard, under arms, at guard mounting. (150)

1712. Color sentinels are not placed on the regular reliefs, nor are their posts numbered. In calling for the corporal of the guard, they call: "**Corporal of the guard. Color line.**" (151)

1713. Officers or enlisted men passing the uncased colors will render the prescribed salute. If the colors are on the stacks, the salute will be made on crossing the color line or on passing the colors. (152)

1714. A sentinel placed over the colors will not permit them to be moved, except in the presence of an armed escort. Unless otherwise ordered by the commanding officer, he will allow no one to touch them but the color bearer.

He will not permit any soldier to take arms from the stacks, or to touch them, except by order of an officer or noncommissioned officer of the guard.

If any person passing the colors or crossing the color line fails to salute the colors, the sentinel will caution him to do so, and if the caution be not heeded he will call the corporal of the guard and report the facts. (153)

Privates of the Guard

1715. Privates are assigned to reliefs by the commander of the guard, and to posts, usually, by the corporal of their relief. They will not change from one relief or post to another during the same tour of guard duty unless by proper authority. (154)

Orders for Sentinels

[Pg 578]

1716. Orders for sentinels are of two classes: General orders and special orders. General orders apply to all sentinels. Special orders relate to particular posts and duties. (155)

1717. Sentinels will be required to memorize the following:

My general orders are:

- 1. To take charge of this post and all Government property in view.**
- 2. To walk my post in a military manner, keeping always on the alert and observing everything that takes place within sight or hearing.**
- 3. To report all violations of orders I am instructed to enforce.**
- 4. To repeat all calls from posts more distant from the guardhouse than my own.**
- 5. To quit my post only when properly relieved.**
- 6. To receive, obey, and pass on to the sentinel who relieves me all orders from the commanding officer, officer of the day, and officers and noncommissioned officers of the guard only.**
- 7. To talk to no one except in line of duty.**
- 8. In case of fire or disorder to give the alarm.**
- 9. To allow no one to commit a nuisance on or near my post.**
- 10. In any case not covered by instructions to call the corporal of the guard.**
- 11. To salute all officers, and all colors and standards not cased.**
- 12. To be especially watchful at night, and, during the time for challenging, to challenge all persons on or near my post, and to allow no one to pass without proper authority.** (156)

Regulations Relating to the General Orders for Sentinels

1718. No. 1: To take charge of this post and all Government property in view.

All persons, of whatever rank in the service, are required to observe respect toward sentinels and members of the guard when such are in the performance of their duties. (157)

1719. A sentinel will at once report to the corporal of the guard every unusual or suspicious occurrence noted. (158)

1720. He will arrest suspicious persons prowling about the post or camp at any time, all parties to a disorder occurring on or near his post, and all, except authorized persons, who attempt to enter the camp at night, and will turn over to the corporal of the guard all persons arrested. (159)

1721. The number, limits, and extent of his post will invariably constitute part of the special orders of a sentinel on post. The limits of his post should be so defined as to include every place to which he is required to go in the performance of his duties.

No. 2: To walk my post in a military manner, keeping always on the alert and observing everything that takes place within sight or hearing. (160)

1722. A sentinel is not required to halt and change the position of his rifle on arriving at the end of his post, nor to execute **to the rear, march**, precisely as prescribed in the drill regulations, but faces about while walking, in the manner most convenient to him, and at any part of his post as may be best suited to the proper performance of his duties. He carries his rifle on either shoulder, and in wet or severe weather, when not in a sentry box, may carry it at a secure. (161)

[Pg 579]

1723. Sentinels when in sentry boxes stand at ease. Sentry boxes will be used in wet weather only, or at other times when specially authorized by the commanding officer. (162)

1724. In very hot weather, sentinels may be authorized to stand at ease on their posts, provided they can effectively discharge their duties in this position, but they will take advantage of this privilege only on the express authority of the officer of the day or the commander of the guard. (163)

1725. A mounted sentinel may dismount occasionally and lead his horse but will not relax his vigilance.

No. 3: To report all violations of orders I am instructed to enforce. (164)

1726. A sentinel will ordinarily report a violation of orders when he is inspected or relieved, but if the case be urgent he will call the corporal of the guard, and also, if necessary, will arrest the offender.

No. 4: To repeat all calls from posts more distant from the guardhouse than my own. (165)

1727. To call the corporal, or the guard, for any purpose other than relief, fire, or disorder ([Pars. 1728](#) and [1734](#)), a sentinel will call, "**Corporal of the guard, No. (—)**," adding the number of his post. In no case will any sentinel call, "**Never mind the corporal**"; nor will the corporal heed such call if given.

No. 5: To quit my post only when properly relieved. (166)

1728. If relief becomes necessary, by reason of sickness or other cause, a sentinel will call, "**Corporal of the guard, No. (—), Relief**," giving the number of his post. (167)

1729. Whenever a sentinel is to be relieved, he will halt, and with arms at a right shoulder, will face toward the relief when it is thirty paces from him. He will come to a port arms with the new sentinel, and in a low tone will transmit to him all the special orders relating to the post, and any other information which will assist him to better perform his duties.

No. 6: To receive, obey, and pass on to the sentinel who relieves me, all orders from the commanding officer, officer of the day, and officers and noncommissioned officers of the guard only. (168)

1730. During this tour of duty a soldier is subject to the orders of the commanding officer, officer of the day, and officers and noncommissioned officers of the guard only; but any officer is competent to investigate apparent violations of regulations by members of the guard. (169)

1731. A sentinel will quit his piece on an explicit order from any person from whom he lawfully receives orders while on post; under no circumstances will he yield it to any other person. Unless necessity therefor exists, no person will require a sentinel to quit his piece, even to allow it to be inspected. (170)

[Pg 580]

1732. A sentinel will not divulge the countersign ([Pars. 1769](#) to 1777) to anyone except the sentinel who relieves him, or to a person from whom he properly receives orders, on such

person's verbal order given personally. Privates of the guard will not use the countersign except in the performance of their duties while posted as sentinels.

No. 7: **To talk to no one except in line of duty.** (171)

1733. When calling for any purpose, challenging, or holding communication with any person, a dismounted sentinel, armed with a rifle or saber, will take the position of "port" arms or saber. At night a dismounted sentinel, armed with a pistol, takes the position of raise pistol in challenging or holding communication. A mounted sentinel does not ordinarily draw his weapon in the daytime when challenging or holding conversation; but if drawn, he holds it at advance rifle, raise pistol, or port saber, according as he is armed with a rifle, pistol, or saber. At night, in challenging and holding conversation, his weapon is drawn and held as just prescribed, depending on whether he is armed with a rifle, pistol, or saber.

No. 8: **In case of fire or disorder to give the alarm.** (172)

1734. In case of fire, a sentinel will call, "**Fire No. (—)**," adding the number of his post; if possible, he will extinguish the fire himself. In case of disorder, he will call: "**The Guard, No. (—)**," adding the number of his post. If the danger be great, he will, in either case, discharge his piece before calling.

No. 11: **To salute all officers and all colors and standards not cased.** (173)

1735. When not engaged in the performance of a specific duty, the proper execution of which would prevent it, a member of the guard will salute all officers who pass him. This rule applies at all hours of the day or night, except in the case of mounted sentinels armed with a rifle or pistol, or dismounted sentinels armed with a pistol, after challenging. (See [Par. 1742.](#)) (174)

1736. Sentinels will salute as follows: A dismounted sentinel armed with a rifle or saber, salutes by presenting arms; if otherwise armed, he salutes with the right hand.

A mounted sentinel, if armed with a saber and the saber be drawn, salutes by presenting saber; otherwise he salutes in all cases with the right hand. (175)

1737. To salute, a dismounted sentinel, with piece at a right shoulder or saber at a carry, halts and faces toward the person to be saluted when the latter arrives within thirty paces.

The limit within which individuals and insignia of rank can be readily recognized is assumed to be about 30 paces, and, therefore, at this distance cognizance is taken of the person or party to be saluted. (176)

1738. The salute is rendered at 6 paces; if the person to be saluted does not arrive within that distance, then when he is nearest. (177)

1739. A sentinel in a sentry box, armed with a rifle, stands at attention in the doorway on the approach of a person or party entitled to salute, and salutes by presenting arms according to the foregoing rules.

[Pg 581]

If armed with a saber, he stands at a carry and salutes as before. (178)

1740. A mounted sentinel on a regular post halts, faces, and salutes in accordance with the foregoing rules. If doing patrol duty, he salutes, but does not halt unless spoken to. (179)

1741. Sentinels salute, in accordance with the foregoing rules, all persons and parties entitled to compliments from the guard ([Pars. 1787](#), and [1788](#)): officers of the Army, Navy, and Marine Corps; military and naval officers of foreign powers; officers of volunteers, and militia officers when in uniform. (180)

1742. A sentinel salutes as just prescribed when an officer comes on his post; if the officer holds communication with the sentinel, the sentinel again salutes when the officer leaves him.

During the hours when challenging is prescribed, the first salute is given as soon as the officer has been duly recognized and advanced. A mounted sentinel armed with a rifle or pistol, or a dismounted sentinel armed with a pistol, does not salute after challenging.

He stands at advance rifle or raise pistol until the officer passes. (181)

1743. In case of the approach of an armed party of the guard, the sentinel will halt when it is about 30 paces from him, facing toward the party with his piece at the right shoulder. If not himself relieved, he will, as the party passes, place himself so that the party will pass in front of him; he resumes walking his post when the party has reached 6 paces beyond him. (182)

An officer is entitled to the compliments prescribed, whether in uniform or not. (183)

1744. A sentinel in communication with an officer will not interrupt the conversation to salute. In the case of seniors the officer will salute, whereupon the sentinel will salute. (184)

1745. When the flag is being lowered at retreat, a sentinel on post and in view of the flag will face the flag, and, at the first note of the "Star Spangled Banner" or to the color will come to a present arms. At the sounding of the last note he will resume walking his post.

No. 12: **To be especially watchful at night and during the time for challenging, to challenge all persons on or near my post, and to allow no one to pass without proper authority.** (185)

1746. During challenging hours, if a sentinel sees any person or party on or near his post, he will advance rapidly along his post toward such person or party and when within about 30 yards will challenge sharply, "**HALT. Who is there?**" He will place himself in the best possible position to receive or, if necessary, to arrest the person or party. (186)

1747. In case a mounted party be challenged, the sentinel will call, "**HALT. DISMOUNT. Who is there?**" (187)

1748. The sentinel will permit only one of any party to approach him for the purpose of giving the countersign ([Pars. 1769](#) to 1777), or if no countersign be used, of being duly recognized. When this is done the whole party is advanced, i. e., allowed to pass. (188)

[Pg 582]

1749. In all cases the sentinel must satisfy himself beyond a reasonable doubt that the parties are what they represent themselves to be and have a right to pass. If he is not satisfied, he must cause them to stand and call the corporal of the guard. So, likewise, if he have no authority to pass persons with the countersign, or when the party has not the countersign, or gives an incorrect one. (189)

1750. A sentinel will not permit any person to approach so close as to prevent the proper use of his own weapon before recognizing the person or receiving the countersign. (190)

1751. When two or more persons approach in one party, the sentinel on receiving an answer that indicates that someone in the party has the countersign, will say, "**Advance one with the countersign,**" and, if the countersign is given correctly, will then say, "**Advance (So and so),**" repeating the answer to his challenge. Thus, if the answer be, "**Relief (friends with the countersign, patrol, etc.),**" the sentinel will say, "**Advance one with the countersign**"; then, "**Advance relief (friends, patrol, etc.).**" (191)

1752. If a person having the countersign approach alone, he is advanced to give the countersign. Thus, if the answer be, "**Friend with the countersign (or officer of the day, or etc.),**" the sentinel will say, "**Advance, friend (or officer of the day, or etc.), with the countersign**"; then, "**Advance, friend (or officer of the day, or etc.).**" (192)

1753. If two or more persons approach a sentinel's post from different directions at the same time, all such persons are challenged in turn and required to halt and to remain halted until advanced.

The senior is first advanced, in accordance with the foregoing rules. (193)

1754. If a party is already advanced and in communication with a sentinel, the latter will challenge any other party that may approach; if the party challenged be senior to the one already on his post, the sentinel will advance the new party at once. The senior may allow him to advance any or all of the other parties; otherwise, the sentinel will not advance any of them until the senior leaves him. He will then advance the senior only of the remaining parties, and so on. (194)

1755. The following order of rank will govern a sentinel in advancing different persons or parties approaching his post: Commanding officer, officer of the day, officer of the guard, officers, patrols, reliefs, noncommissioned officers of the guard in order of rank, friends. (195)

1756. A sentinel will never allow himself to be surprised, nor permit two parties to advance upon him at the same time. (196)

1757. If no countersign be used, the rules for challenging are the same. The rules for advancing parties are modified only as follows: Instead of saying "**Advance (so and so) with the countersign,**" the sentinel will say, "**Advance (so and so) to be recognized.**" Upon recognition he will say, "**Advance (so and so).**" (197)

1758. Answers to a sentinel's challenge intended to confuse or mislead him are prohibited, but the use of such an answer as "**Friends with the countersign,**" is not to be understood as misleading, but as the usual answer made by officers, patrols, etc., when the purpose of their visit makes it desirable that their official capacity should not be announced. (198)

[Pg 583]

Special Orders For Sentinels at the Post of the Guard

1759. Sentinels posted at the guard will be required to memorize the following:

Between reveille and retreat to turn out the guard for all persons designated by the commanding officer, for all colors or standards not cased, and in time of war for all armed parties approaching my post, except troops at drill and reliefs and detachments of the guard.

At night, after challenging any person or party, to advance no one but call the corporal of the guard, repeating the answer to the challenge. (199)

1760. After receiving an answer to his challenge, the sentinel calls, "**Corporal of the guard (So and so)**," repeating the answer to the challenge.

He does not in such cases repeat the number of his post. (200)

1761. He remains in the position assumed in challenging until the corporal has recognized or advanced the person or party challenged, when he resumes walking his post, or, if the person or party be entitled thereto, he salutes and, as soon as the salute has been acknowledged, resumes walking his post. (201)

1762. The sentinel at the post of the guard will be notified by direction of the commanding officer of the presence in camp or garrison of persons entitled to the compliment ([Par. 1784.](#)) (202)

1763. The following examples illustrate the manner in which the sentinel at the post of the guard will turn out the guard upon the approach of persons or parties entitled to the compliment ([Pars. 1784, 1787, and 1788](#)): "**Turn out the guard, Commanding Officer**"; "**Turn out the guard, Governor of a Territory**"; "**Turn out the guard, national colors**"; "**Turn out the guard, armed party**"; etc.

At the approach of the new guard at guard mounting the sentinel will call "**Turn out the guard, armed party.**" (203)

1764. Should the person named by the sentinel not desire the guard formed, he will salute, whereupon the sentinel will call "**Never mind the guard.**" (204)

1765. After having called "**Turn out the guard,**" the sentinel will never call "**Never mind the guard,**" on the approach of an armed party. (205)

1766. Though the guard be already formed he will not fail to call "**Turn out the guard,**" as required in his special orders, except that the guard will not be turned out for any person while his senior is at or coming to the post of the guard. (206)

1767. The sentinels at the post of the guard will warn the commander of the approach of any armed body and of the presence in the vicinity of all suspicious or disorderly persons. (207)

1768. In case of fire or disorder in sight or hearing, the sentinel at the guardhouse will call the corporal of the guard and report the facts to him. (208)

Countersigns and Paroles

[Pg 584]

1769. Seventy-seventh Article of War. Any person subject to military law makes known the parole or countersign to any person not entitled to receive it according to the rules and discipline of war, or gives a parole or countersign different from that which he received, shall, if the offense be committed in time of war, suffer death or such other punishment as a court-martial may direct. (See [Par. 1732.](#)) (209)

1770. The **countersign** is a word given daily from the principal headquarters of a command to aid guards and sentinels in identifying persons who may be authorized to pass at night.

It is given to such persons as may be authorized to pass and repass sentinels' posts during the night, and to officers, noncommissioned officers, and sentinels of the guard. (210)

1771. The **parole** is a word used as a check on the countersign in order to obtain more accurate identification of persons. It is imparted only to those who are entitled to inspect guards and to commanders of guards.

The parole or countersign, or both, are sent sealed in the form of an order to those entitled to them. (211)

1772. When the commander of the guard demands the parole, he will advance and receive it as the corporal receives the countersign. (See [Par. 1695.](#)) (212)

1773. As the communications containing the parole and countersign must at times be distributed by many orderlies, the parole intrusted to many officers, and the countersign and parole to many officers and sentinels, and as both the countersign and parole must, for large commands, be prepared several days in advance, there is always danger of their being lost or becoming known

to persons who would make improper use of them; moreover, a sentinel is too apt to take it for granted that any person who gives the right countersign is what he represents himself to be; hence for outpost duty there is greater security in omitting the use of the countersign and parole, or in using them with great caution. The chief reliance should be upon personal recognition or identification of all persons claiming authority to pass.

Persons whose sole means of identification is the countersign, or concerning whose authority to pass there is a reasonable doubt, should not be allowed to pass without the authority of the corporal of the guard after proper investigation; the corporal will take to his next superior any person about whom he is not competent to decide. (213)

1774. The **countersign** is usually the name of a battle; the **parole**, that of a general or other distinguished person. (214)

1775. When they can not be communicated daily, a series of words for some days in advance may be sent to posts or detachments that are to use the same parole or countersign as the main body. (215)

1776. If the countersign be lost, or if a member of the guard desert with it, the commander on the spot will substitute another for it and report the case at once to headquarters. (216)

1777. In addition to the countersign, use may be made of preconcerted signals, such as striking the rifle with the hand or striking the hands together a certain number of times, as agreed upon. Such signals may be used only by guards that occupy exposed points.

They are used before the countersign is given, and must not be communicated to anyone not entitled to know the countersign. Their use is intended to prevent the surprise of a sentinel. [Pg 585]

In the daytime signals such as raising a cap or a handkerchief in a prearranged manner may be used by sentinels to communicate with the guard or with each other. (217)

Guard Patrols

1778. A guard patrol consists of one or more men detailed for the performance of some special service connected with guard duty. (218)

1779. If the patrol be required to go beyond the chain of sentinels, the officer or noncommissioned officer in charge will be furnished with the countersign, and the outposts and sentinels warned. (219)

1780. If challenged by a sentinel, the patrol is halted by its commander, and the noncommissioned officer accompanying it advances alone and gives the countersign. (220)

Watchmen

1781. Enlisted men may be detailed as watchmen or as overseers over prisoners, and as such will receive their orders and perform their duties as the commanding officer may direct. (221)

Compliments From Guards

1782. The compliment from a guard consists in the guard turning out and presenting arms. (See [Par. 1612](#).) No compliments will be paid between retreat and reveille except as provided in [paragraphs 361](#) and [362](#), nor will any person other than those named in [paragraph 224](#) receive the compliment. (222)

1783. Though a guard does not turn out between retreat and reveille as a matter of compliment, it may be turned out for inspection at any time by a person entitled to inspect it. (223)

1784. Between reveille and retreat the following persons are entitled to the compliment: The President, sovereign or chief magistrate of a foreign country, and members of a royal family; Vice-President; President and President pro tempore of the Senate; American and foreign ambassadors; members of the Cabinet; Chief Justice; Speaker of the House of Representatives; committees of Congress officially visiting a military post; governors within their respective States and Territories; governors general^[20]; Assistant Secretary of War officially visiting a military post; all general officers of the Army; general officers of foreign services visiting a post; naval, marine, volunteer, and militia officers in the service of the United States and holding the rank of general officer; American or foreign envoys or ministers; ministers accredited to the United States; chargés d'affaires accredited to the United States; consuls general accredited to the United States; commanding officer of a coast artillery district, coast defense command, post, fort or camp; officer of the day. (224) (C. M. I. G. D., No. 1, Feb. 24, 1915.)

1785. The relative rank between officers of the Army and Navy is as follows: General with admiral, lieutenant general with the vice admiral, major general with rear admiral, brigadier [Pg 586]

general with commodore,^[21] colonel with captain, lieutenant colonel with commander, major with lieutenant commander, captain with lieutenant, first lieutenant with lieutenant (junior grade), second lieutenant with ensign. (A. R. 12.) (225)

1786. Sentinels will not be required to memorize [paragraph 1784](#), and except in the cases of general officers of the Army, the commanding officer, and the officer of the day, they will be advised in each case of the presence in camp or garrison of persons entitled to the compliment. (226)

1787. Guards will turn out and present arms when the national or regimental colors or standards, not cased, are carried past by a guard or an armed party. This rule also applies when the party carrying the colors is at drill. If the drill is conducted in the vicinity of the guardhouse, the guard will be turned out when the colors first pass, and not thereafter. (227)

1788. In case the remains of a deceased officer or soldier are carried past, the guard will turn out and present arms. (228)

1789. In time of war all guards will turn out under arms when armed parties, except troops at drill and reliefs or detachments of the guard, approach their post. (See [Par. 1615.](#)) (229)

1790. The commander of the guard will be notified of the presence in camp or garrison of all persons entitled to the compliment, except general officers of the Army, the commanding officer, and the officer of the day. Members of the guard will salute all persons entitled to the compliment and all officers in the military or naval service of foreign powers, officers of the Army, Navy and Marine Corps, officers of volunteers, and officers of militia when in uniform. (230)

General Rules Concerning Guard Duty

1791. Eighty-sixth Article of War. Any sentinel who is found drunk or sleeping upon his post, or who leaves it before he is regularly relieved, shall, if the offense be committed in time of war, suffer death or such other punishment as a court-martial may direct; and if the offense be committed in time of peace, he shall suffer any punishment, except death, that a court-martial may direct. (232)

1792. All material instructions given to a member of the guard by an officer having authority will be promptly communicated to the commander of the guard by the officer giving them. (233)

1793. Should the guard be formed, soldiers will fall in ranks under arms. At roll call, each man, as his name or number and relief are called, will answer "Here," and come to an **order arms**. (234)

1794. Whenever the guard or a relief is dismissed, each member not at once required for duty will place his rifle in the arms racks, if they be provided, and will not remove it therefrom unless he requires it in the performance of some duty. (235)

[Pg 587]

1795. Without permission from the commander of the guard, members of the main guard, except orderlies, will not leave the immediate vicinity of the guard house. Permission to leave will not be granted except in cases of necessity. (236)

1796. Members of the main guard, except orderlies, will not remove their accouterments or clothing without permission from the commander of the guard. ([Par. 1628.](#)) (237)

Guarding Prisoners

1797. The sentinel at the post of the guard has charge of the prisoners except when they have been turned over to the prisoner guard or overseers. ([Par. 1798](#) to 1802 and [300](#) to 304.)

(a) **He will allow none to escape.**

(b) **He will allow none to cross his post leaving the guardhouse except when passed by an officer or noncommissioned officer of the guard.**

(c) **He will allow no one to communicate with prisoners without permission from proper authority.**

(d) **He will promptly report to the corporal of the guard any suspicious noise made by the prisoners.**

(e) **He will be prepared to tell whenever asked how many prisoners are in the guardhouse and how many are out at work or elsewhere.**

Whenever prisoners are brought to his post returning from work or elsewhere, he will halt them and call the corporal of the guard, notifying him of the number of prisoners returning. Thus:

"Corporal of the guard, (so many) prisoners."

He will not allow prisoners to pass into the guardhouse until the corporal of the guard has responded to the call and ordered him to do so. (299)

1798. Whenever practicable special guards will be detailed for the particular duty of guarding working parties composed of such prisoners as cannot be placed under overseers. (300)

1799. The prisoner guard and overseers will be commanded by the police officer; if there be no police officer, then by the officer of the day. (301)

1800. The provost sergeant is sergeant of the prisoner guard and overseers, and as such receives orders from the commanding officer and the commander of the prisoner guard only. (302)

1801. Details for prisoner guard are marched to the guardhouse and mounted by being inspected by the commander of the main guard, who determines whether all of the men are in proper condition to perform their duties and whether their arms and equipments are in proper condition, and rejects any men found unfit. (303)

1802. When prisoners have been turned over to the prisoner guard or overseers, such guards or overseers are responsible for them under their commander, and all responsibility and control of the main guard ceases until they are returned to the main guard. ([Par. 1804.](#)) (304)

1803. If a prisoner attempts to escape, the sentinel will call "**Halt.**" If he fails to halt when the sentinel has once repeated his call, and if there be no other possible means of preventing his escape, the sentinel will fire upon him.

[Pg 588]

1804. On approaching the post of the sentinel at the guardhouse, a sentinel of the prisoner guard or an overseer in charge of prisoners will halt them and call, "**No. 1, (so many prisoners.)**" He will not allow them to cross the post of the sentinel until so directed by the Corporal of the guard. (306)

1805. Members of the prisoner guard and overseers placed over prisoners for work will receive specific and explicit instructions covering the required work; they will be held strictly responsible that the prisoners under their charge properly and satisfactorily perform the designated work. (307)

Stable Guards

1806. Under the head of stable guards will be included guards for cavalry stables, artillery stables and parks, mounted infantry stables, machine-gun organization stables and parks, and quartermaster stables and parks. Where the words "troop" and "cavalry" are used they will be held to include all of these organizations. (308)

1807. When troop stable guards are mounted they will guard the stables of the cavalry. When no stable guards are mounted, the stables will be guarded by sentinels posted from the main guard, under the control of the officer of the day.

The instructions given for troop stable guard will be observed as far as applicable by the noncommissioned officers and sentinels of the main guard when in charge of the stables. (309)

Troop Stable Guards

1808. Troops stable guards will not be used except in the field, or when it is impracticable to guard the stables by sentinels from the main guard. (310)

1809. Troop stable guards will be under the immediate control of their respective troop commanders; they will be posted in each cavalry stable, or near the picket line, and will consist of not less than one noncommissioned officer and three privates.

Stable guards are for the protection of the horses, stables, forage, equipments, and public property generally. They will in addition enforce the special regulations in regard to stables, horses, and parks. (311)

1810. Sentinels of stable guards will be posted at the stables or at the picket lines when the horses are kept outside. The troop stable guard may be used as a herd guard during the day time or when grazing is practicable. (312)

1811. The troop stable guard, when authorized by the post commander, will be mounted under the supervision of the troop commander. It will be armed, at the discretion of the troop commander, with either rifle or pistol. (313)

1812. The tour continues for 24 hours, or until the guard is relieved by a new guard. (314)

[Pg 589]

1813. The employment of stable guards for police and fatigue duties at the stables is forbidden; but this will not prohibit them from being required to assist in feeding grain before reveille. (315)

The troop stable guard will attend stables with the rest of the troop and groom their own horses, the sentinels being taken off post for the purpose. (316)

1814. Neither the noncommissioned officer nor the members of the stable guard will absent themselves from the immediate vicinity of the stables except in case of urgent necessity, and then for no longer time than is absolutely necessary. No member of the guard will leave for any purpose without the authority of the noncommissioned officer of the guard. (317)

1815. The noncommissioned officer and one member of the stable guard will go for meals at the proper hour; upon their return the other members of the guard will be directed to go by the noncommissioned officer. (318)

1816. When the horses are herded each troop will furnish its own herd guard. (319)

1817. Smoking in the stables or their immediate vicinity is prohibited. No fire or light, other than electric light or stable lanterns, will be permitted in the stables. A special place will be designated for trimming, filling, and lighting lanterns. (320)

Noncommissioned Officer of the Troop Stable Guard

1818. The noncommissioned officer receives his orders from his troop commander, to whom he will report immediately after posting his first relief, and when relieved will turn over all his orders to his successor. He instructs his sentinels in their general and special duties; exercises general supervision over his entire guard; exacts order and cleanliness about the guardroom; prevents the introduction of intoxicants into the guardhouse and stables; receives, by count, from his predecessor, the animals, horse equipments, and all property (both private and public) pertaining thereto; examines, before relieving his predecessor, all locks, windows, and doors, and should any be found insecure he will report the fact to his troop commander when he reports for orders. He will personally post and relieve each sentinel, taking care to verify the property responsibility of the sentinel who comes off post, and see that the sentinel who goes on post is aware of the property responsibility that he assumes. (321)

1819. That the noncommissioned officer may be more thoroughly informed of his responsibility, **all** horses returning, except those from a regular formation, will be reported to him. He will then notify the sentinel on post, and, in the absence of the stable sergeant, will see that the horses are promptly cared for.

In case of abuse, he will promptly report to the troop commander. Should the horse be the private property of an officer, he will report such abuse to the owner. (322)

1820. The noncommissioned officer will report any unusual occurrence during his tour direct to his troop commander. (323)

1821. Horses and other property for which the noncommissioned officer is responsible will not be taken from the stables without the authority of the post or troop commander. (324)

[Pg 590]

1822. The noncommissioned officer must answer the sentinel's calls promptly. (325)

1823. In case of fire, the noncommissioned officer will see that the requirements of [paragraph 1831](#) are promptly carried out. (326)

1824. Whenever it becomes necessary for the noncommissioned officer to leave his guard, he will designate a member of it to take charge and assume his responsibility during his absence. (327)

Sentinels of the Troop Stable Guard

1825. The sentinel in the discharge of his duties will be governed by the regulations for sentinels of the main guard whenever they are applicable—such as courtesies to officers, walking post in a soldierly manner, challenging, etc.; he will not turn out the guard except when ordered by proper authority. (328)

1826. The sentinel will receive orders from the commanding officer, the troop commander, and the noncommissioned officers of the stable guard only, except when the commanding officer directs the officer of the day to inspect the stable guard. (329)

1827. In the field and elsewhere when directed by the commanding officer the sentinel when posted will verify the number of horses for which he is responsible, and when relieved will give the number to his successor. (330)

1828. The sentinel will not permit any horse or equipments to be taken from the stables, except

in the presence of the noncommissioned officer. (331)

1829. Should a horse get loose, the sentinel will catch him and tie him up. If he be unable to catch the horse, the noncommissioned officer will at once be notified. In case a horse be cast, or in any way entangled, he will relieve him, if possible; if unable to relieve him, he will call the noncommissioned officer. Sentinels are forbidden to punish or maltreat a horse. (332)

1830. When a horse is taken sick, the sentinel will notify the noncommissioned officer, who in turn will call the farrier, and see that the horse is properly attended to. (333)

1831. In case of fire the sentinel will give the alarm by stepping outside the stable and firing his pistol or piece repeatedly, and calling out at the same time, "**Fire, stables, Troop (—)**."

As soon as the guard is alarmed, he will take the necessary precautions in opening or closing the doors so as to prevent the spreading of the fire and make it possible to remove the horses; he will drop the chains and bars, and, with the other members of the guard, proceed to lead out the horses and secure them at the picket line or such other place as may have been previously designated. (334)

1832. Sentinels over horses, or in charge of prisoners, receive orders from the stable sergeant, so far as the care of the horses and the labor of prisoners are concerned. (335)

1833. In field artillery and machine-gun organizations, the guard for the stables has charge of the guns, caissons, etc., with their ammunition and stores, as well as the horses, harness, and forage. (336)

[Pg 591]

The Flag

1834. The lowering of the flag will be regulated as to be completed at the last note of "The Star Spangled Banner" or "to the color." (338)

1835. When practicable, a detail consisting of a noncommissioned officer and two privates of the guard will raise or lower the flag. This detail wears side arms or, if the special equipments do not include side arms, then belts only.

The noncommissioned officer, carrying the flag, forms the detail in line, takes his post in the center, and marches it to the staff. The flag is then securely attached to the halyards and rapidly hoisted. The halyards are then securely fastened to the cleat on the staff and the detail marched to the guardhouse. (344)

1836. When the flag is to be lowered, the halyards are loosened from the staff and made perfectly free. At retreat the flag is lowered at the last note of retreat. It is then neatly folded and the halyards made fast. The detail is then reformed and marched to the guardhouse, where the flag is turned over to the commander of the guard.

The flag should never be allowed to touch the ground and should always be hoisted or lowered from the leeward side of the staff, the halyards being held by two persons. (345)

Reveille and Retreat Gun

1837. The morning and evening gun will be fired by a detachment of the guard, consisting, when practicable, of a corporal and two privates. The morning gun is fired at the first note of reveille, or, if marches be played before the reveille, it is fired at the beginning of the first march. The retreat gun is fired at the last note of retreat.

The corporal marches the detachment to and from the piece, which is fired, sponged out, and secured under his direction. (346)

Guard Mounting

1838. Guard mounting will be formal or informal as the commanding officer may direct. It will be held as prescribed in the drill regulations of the arm of the service to which the guard belongs; if none is prescribed, then as for infantry. In case the guard is composed wholly of mounted organizations, guard mounting may be held mounted. (347)

1839. When infantry and mounted troops dismounted are united for guard mounting, all details form as prescribed for infantry. (348)

Formal Guard Mounting for Infantry

1840. Formal guard mounting will ordinarily be held only in posts or camps where a band is present. (349)

1841. At the **assembly**, the men designated for the guard fall in on their company parade grounds as prescribed in paragraph 106. I. D. R. The first sergeant then verifies the detail, inspects it, replaces any man unfit to go on guard, turns the detail over to the senior noncommissioned officer, and retires. The band takes its place on the parade ground so that the left of its front rank shall be 12 paces to the right of the front rank of the guard when the latter is formed. (350)

1842. At **adjutant's call**, the adjutant, dismounted, and the sergeant-major on his left, marches to the parade ground. The adjutant halts and takes post so as to be 12 paces in front of and facing the center of the guard when formed; the sergeant-major continues on, moves by the left flank, and takes post, facing to the left, 12 paces to the left of the front rank of the band; the band plays in quick or double time; the details are marched to the parade ground by the senior noncommissioned officers; the detail that arrives first is marched to the line so that, upon halting, the breast of the front-rank man shall be near to and opposite the left arm of the sergeant-major; the commander of the detail halts his detail, places himself in front of and facing the sergeant-major, at a distance equal to or a little greater than the front of his detail, and commands: **1. Right, 2. DRESS.** The detail dresses up to the line of the sergeant-major and its commander, the right front-rank man placing his breast against the left arm of the sergeant-major; the noncommissioned officers take post two paces in rear of the rear rank of the detail. The detail aligned, the commander of the detail commands: **FRONT**, salutes, and then reports: "**The detail is correct;**" or "**So many sergeants, corporals, or privates are absent;**" the sergeant-major returns the salute with the right hand after the report is made; the commander then passes by the right of the guard and takes post in the line of noncommissioned officers in rear of the right file or his detail.

Should there be more than one detail, it is formed in like manner on the left of the one preceding; the privates, noncommissioned officers, and commander of each detail dress on those of the preceding details in the same rank or line; each detail commander closes the rear rank to the right and fills blank files, as far as practicable, with the men from his front rank.

Should the guard from a company not include a noncommissioned officer, one will be detailed to perform the duties of commander of the detail. In this case the commander of the detail, after reporting to the sergeant-major, passes around the right flank between the guard and the band and retires. (351)

1843. When the last detail has formed, the sergeant-major takes a side step to the right, draws sword, verifies the detail, takes post two paces to the right and two paces to the front of the guard, facing to the left, causes the guard to count off, completes the left squad, if necessary, as in the school of the company, and if there be more than three squads, divides the guard into two platoons, again takes post as described above and commands: **1. Open ranks, 2. MARCH.**

At the command **march**, the rear rank and file closers march backward four steps, halt, and dress to the right. The sergeant major aligns the ranks and file closers and again, taking post as described above, commands: **FRONT**, moves parallel to the front rank until opposite the center, turns to the right, halts midway to the adjutant, salutes, and reports: "**Sir, the details are correct;**" or, "**Sir, (so many) sergeants, corporals, or privates are absent;**" the adjutant returns the salute, directs the sergeant-major: **Take your post**, and then draws saber; the sergeant-major faces about, approaches to within two paces of the center of the front rank, turns to the right, moves three paces beyond the left of the front rank, turns to the left, halts on the line of the front rank, faces about, and brings his sword to the order. When the sergeant-major has reported, the officer of the guard takes post, facing to the front, three paces in front of the center of the guard, and draws saber.

The adjutant then commands: **1. Officer (or officers) and noncommissioned officers, 2. Front and Center, 3. MARCH.**

At the command **center**, the officers carry saber. At the command **march**, the officer advances and halts three paces from the adjutant, remaining at the carry; the noncommissioned officers pass by the flanks, along the front, and form in order of rank from right to left, three paces in rear of the officer, remaining at the right shoulder; if there is no officer of the guard the noncommissioned officers halt on a line three paces from the adjutant; the adjutant then assigns the officers and noncommissioned officers according to rank, as follows: **Commander of the guard, leader of first platoon, leader of second platoon, right guide of first platoon, left guide of second platoon, left guide of first platoon, right guide of second platoon, and file closers**, or, if the guard is not divided into platoons: **Commander of the guard, right guide, left guide, and file closers.**

The adjutant then commands: **1. Officer (or officers) and noncommissioned officers, 2. POSTS, 3. MARCH.**

At the command **posts**, all, except the officer commanding the guard, face about. At the command **march**, they take the posts prescribed in the school of the company with open ranks. The adjutant directs: **Inspect your guard, sir**; at which the officer commanding the guard faces about, commands: **Prepare for inspection**, returns saber, and inspects the guard.

During the inspection, the band plays; the adjutant returns saber, observes the general condition of the guard, and falls out any man who is unfit for guard duty or does not present a creditable appearance. Substitutes will report to the commander of the guard at the guardhouse. (352)

1844. The adjutant, when so directed, selects orderlies and color sentinels, as prescribed in [paragraphs 140](#) and [141](#), and notifies the commander of the guard of his selection. (353)

If there be a junior officer of the guard he takes post at the same time as the senior, facing to the front, 3 paces in front of the center of the first platoon; in going to the front and center he follows and takes position on the left of the senior and is assigned as leader of the first platoon; he may be directed by the commander of the guard to assist in inspecting the guard.

If there be no officer of the guard, the adjutant inspects the guard. A noncommissioned officer commanding the guard takes post on the right of the right guide, when the guard is in line; and takes the post of the officer of the guard, when in column or passing in review. (354)

[Pg 594]

1845. The inspection ended, the adjutant places himself about 30 paces in front of and facing the center of the guard, and draws saber; the new officer of the day takes post in front of and facing the guard, about 30 paces from the adjutant; the old officer of the day takes post 3 paces to the right of and 1 pace to the rear of the new officer of the day; the officer of the guard takes post 3 paces in front of its center, draws saber with the adjutant and comes to the order; thereafter he takes the same relative positions as a captain of a company.

The adjutant then commands: **1. Parade, 2. REST, 3. SOUND OFF**, and comes to the order and parade rest.

The band, playing, passes in front of the officer of the guard to the left of the line, and back to its post on the right, when it ceases playing.

The adjutant then comes to attention, carries saber, and commands: **1. Guard, 2. ATTENTION, 3. Close ranks, 4. MARCH.**

The ranks are opened and closed as in paragraph 745, I. D. R.

The adjutant then commands: **1. Present, 2. ARMS**, faces toward the new officer of the day, salutes, and then reports: **Sir, the guard is formed.** The new officer of the day, after the adjutant has reported, returns the salute with the hand and directs the adjutant: **March the guard in review, sir.**

The adjutant carries saber, faces about, brings the guard to an order, and commands: **1. At trail, platoons (or guard) right, 2. MARCH, 3. Guard, 4. HALT.**

The platoons execute the movements; the band turns to the right and places itself 12 paces in front of the first platoon.

The adjutant places himself 6 paces from the flank and abreast of the commander of the guard; the sergeant major, 6 paces from the left flank of the second platoon.

The adjutant then commands: **1. Pass in review, 2. FORWARD, 3. MARCH.**

The guard marches in quick time past the officer of the day, according to the principles of review, and is brought to **eyes right** at the proper time by the commander of the guard; the adjutant, commander of the guard, leaders of platoons, sergeant-major, and drum major salute.

The band, having passed the officer of the day, turns to the left out of the column, places itself opposite and facing him, and continues to play until the guard leaves the parade ground. The field music detaches itself from the band when the latter turns out of the column, and, remaining in front of the guard, commences to play when the band ceases.

Having passed 12 paces beyond the officer of the day, the adjutant halts; the sergeant-major halts abreast of the adjutant and 1 pace to his left; they then return saber, salute, and retire; the commander of the guard then commands: **1. Platoons, right by squads, 2. MARCH**, and marches the guard to its post.

The officers of the day face toward each other and salute; the old officer of the day turns over the orders to the new officer of the day.

When the band is sounding off, and while the guard is marching in review, the officers of the day stand at parade rest with arms folded. They take this position when the adjutant comes to parade rest, resume the attention with him, again take the parade rest at the first note of the march in review, and resume attention as the head of the column approaches.

[Pg 595]

The new officer of the day returns the salute of the commander of the guard and the adjutant, making one salute with the hand. (355)

1846. If the guard be not divided into platoons, the adjutant commands: **1. At trail, guard right, 2. MARCH, 3. Guard, 4. HALT**, and it passes in review as above; the commander of the

guard is 3 paces in front of its center; the adjutant places himself 6 paces from the left flank and abreast of the commander of the guard; the sergeant covers the adjutant on a line with the front rank. (356)

Informal Guard Mounting for Infantry

1847. Informal guard mounting will be held on the parade ground of the organization from which the guard is detailed. If it is detailed from more than one organization, then at such place as the commanding officer may direct. (357)

1848. At assembly, the detail for guard falls in on the company parade ground. The first sergeant verifies the detail, inspects their dress and general appearance, and replaces any man unfit to march on guard. He then turns the detail over to the commander of the guard and retires. (358)

1849. At adjutant's call, the officer of the day takes his place 15 paces in front of the center of the guard and commands: **1. Officer (or officers) and noncommissioned officers, 2. Front and center, 3. MARCH;** whereupon the officers and noncommissioned officers take their positions, are assigned and sent to their posts as prescribed in formal guard mounting. ([Par. 1843.](#))

The officer of the day will then inspect the guard with especial reference for its fitness for the duty for which it is detailed, and will select as prescribed in [paragraphs 1702](#), the necessary orderlies and color sentinels. The men found unfit for guard will be returned to quarters and will be replaced by others found to be suitable, if available in the company. If none are available in the company, the fact will be reported to the adjutant immediately after guard mounting.

When the inspection shall have been completed, the officer of the day resumes his position and directs the commander of the guard to march the guard to its post. (359)

Relieving the Old Guard

1850. As the new guard approaches the guardhouse, the old guard is formed in line, with its field music 3 paces to its right; and when the field music at the head of the new guard arrives opposite its left, the commander of the new guard commands: **1. Eyes, 2. RIGHT;** the commander of the old guard commands: **1. Present, 2. ARMS;** commanders of both guards salute. The new guard marches in quick time past the old guard.

When the commander of the new guard is opposite the field music of the old guard, he commands: **FRONT;** the commander of the old guard commands: **1. Order, 2. ARMS,** as soon as the new guard shall have cleared the old guard.

[Pg 596]

The field music having marched 3 paces beyond the field music of the old guard, changes direction to the right, and, followed by the guard, changes direction to the left when on a line with the old guard; the changes of direction are without command. The commander of the guard halts on the line of the front rank of the old guard, allows his guard to march past him, and when its rear approaches forms it in line to the left, establishes the left guide 3 paces to the right of the field music of the old guard, and on a line with the front rank, and then dresses his guard to the left; the field music of the new guard is 3 paces to the right of its front rank. (360)

1851. The new guard being dressed, the commander of each guard, in front of and facing its center, commands: **1. Present, 2. ARMS,** resumes his front, salutes, carries saber, faces his guard and commands: **1. Order, 2. ARMS.**

Should a guard be commanded by a noncommissioned officer, he stands on the right or left of the front rank, according as he commands the old or new guard, and executes the rifle salute. (361)

1852. After the new guard arrives at its post, and has saluted the old guard, each guard is presented by its commander to its officer of the day; if there be but one officer of the day present, or if one officer acts in the capacity of old and new officer of the day, each guard is presented to him by its commander. (362)

1853. If other persons entitled to a salute approach, each commander of the guard will bring his own guard to attention if not already at attention. The senior commander of the two guards will then command "**1. Old and new guards, 2. Present, 3. ARMS.**"

The junior will salute at the command "**Present Arms**" given by the senior. After the salute has been acknowledged, the senior brings both guards to the order. (363)

1854. After the salutes have been acknowledged by the officers of the day, each guard is brought to an order by its commander; the commander of the new guard then directs the orderly or orderlies to fall out and report, and causes bayonets to be fixed if so ordered by the commanding officer; bayonets will not then be unfixd during the tour except in route marches while the guard is actually marching, or when specially directed by the commanding officer.

The commander of the new guard then falls out members of the guard for detached posts, placing them under charge of the proper noncommissioned officers, divides the guard into three reliefs, **first**, **second**, and **third**, from right to left, and directs a list of the guard to be made by reliefs. When the guard consists of troops of different arms combined, the men are assigned to reliefs so as to insure a fair division of duty, under rules prescribed by the commanding officer. (364)

1855. The sentinels and detachments of the old guard are at once relieved by members of the new guard; the two guards standing at ease or at rest while these changes are being made. The commander of the old transmits to the commander of the new guard all his orders, instructions, and information concerning the guard and its duties. The commander of the new guard then takes possession of the guardhouse and verifies the articles in charge of the guard. (365)

[Pg 597]

1856. If considerable time is required to bring in that portion of the old guard still on post, the commanding officer may direct that as soon as the orders and property are turned over to the new guard, the portion of the old guard at the guardhouse may be marched off and dismissed. In such a case, the remaining detachment or detachments of the old guard will be inspected by the commander of the new guard when they reach the guardhouse. He will direct the senior noncommissioned officer present to march these detachments off and dismiss them in the prescribed manner. (366)

1857. In bad weather, at night, after long marches, or when the guard is very small, the field music may be dispensed with. (367)

FOOTNOTES:

[20] The term "governors general" shall be taken to mean administrative officers under whom officers with the title of governor are acting.

[21] The grade of commodore ceased to exist as a grade on the active list of the Navy of the United States on Mar. 3, 1899. By section 7 of the act of Mar. 3, 1899, the nine junior rear admirals are authorized to receive the pay and allowances of a brigadier general of the Army.

PART VIII

[Pg 598]

MILITARY ORGANIZATION

1858. The tabulations that follow are based on the National Defense Act of June 3, 1916, and on the Tables of Organization.

[Pg 599]

Composition of Infantry Units

Regiment	Battalions (3)	Companies			
		Each	Each	Infantry (12)	Headquarters (1)
1 Colonel	1 Major	1 Captain	1 Captain, mounted,	1 Captain, Mtd.	1 Captain, Mtd.
1 Lt.	1 1st	1 1st Lieut.	(Regtl. Adjt.)	1 1st Lt., Mtd.	1 2nd Lt., Mtd.
Colonel	Lieut., mounted	1 2nd Lieut.	—	2 2nd Lts., Mtd.	—
3 Majors	(battalion adjutant)	—	1 Regtl. Sergt. Major, mounted.	—	2
15	4	3	3 Batln.	4	—
Captains	Companies.	1 1st Sergt.	Sergts. Major, mounted.	—	3 Regtl. Supply
16 1st	<i>Attached</i>	1 Mess	1 1st Sergt. (drum major)	1 1st Sergt., Mtd.	Sergts., Mtd.
Lieuts.	1 Battalion	Sergt.	2 Color Sergts.	1 Mess Sergt.	1 1st Sergt., Mtd.
15 2nd	Sergt.	1 Supply	1 Mess Sergt.	1 Supply Sergt., Mtd.	1 Mess Sergt.
Lieuts.	Major	Sergt.	1 Supply Sergt.	1 Stable Sergt. Mtd.	1 Stable Sergt.
—	(from Hdqrs. Co.)	6 Sergts.	19 Pvts. (1st Class)	1 Stable Sergt., Mtd.	1 Corpl., Mtd.
51		11 Corpls.	56 Pvts.	1	1 Cook
—		2 Cooks	—	Horseshoer	1 Saddler
1 Hdqrs. Co.		2 Buglers	100		
1 Machine Gun Co.		1 Mechanic	—		
1 Supply Co.		19 Pvts. (1st Class)	—		
12		56 Pvts.	—		
Infantry Cos.,		100	—		
		—	1 Horseshoer		
			1 Band leader		
			1 Asst. Band		

organized into 3 battalions of 4 companies each <i>Attached</i> 1 Major, Med. Dept. 3 Capts., or 1st Lieuts., Med. Dept. 1 Chaplain		(The President may add 2 Sergts., 6 Corpls., 1 Mechanic, 9 Pvts. 1st Class and 31 Pvts.— total, 49)	leader 1 Sergt. bugler 2 Band Sergts. 4 Band Corpls. 2 Musicians, 1st Class 4 Musicians, 2nd Class 13 Musicians, 3rd Class 4 Pvts., 1st Class, Mtd. 12 Pvts, Mtd. — 58 —	5 Sergeants 6 Corporals 2 Cooks 2 Buglers 1 Mechanic 8 Pvts., 1st Class 24 Privates — 53 — (The President may add 2 Sergts., 2 Corpls., 1 Mechanic, 4 Pvts., 1st Class and 12 Pvts.— total, 21)	1 Horseshoer 1 Wagoner for each authorized wagon of the field and combat train.
---	--	---	--	--	--

Transportation, orderlies, etc. To Hdqrs. Co., 27 riding horses; to Machine Gun Co., 6 riding horses and 8 pack mules; to Supply Co., 3 riding horses; to each Battalion Hdqrs., 6 riding horses, 1 wagon, 4 draft mules, and 2 mounted orderlies; to Regtl. Hdqrs., 5 riding horses.

Composition of Cavalry Units

[Pg 600]

Regiment	Squadrons (3)	Troops			
		Each	Each	Cavalry (12)	Headquarters (1)
1 Colonel 1 Lt. Colonel 3 Majors 15 Captains 16 1st Lieuts. 16 2nd Lieuts. — 52 — 1 Hdqrs. Troop 1 Machine Gun Troop 1 Supply Troop 12 Troops organized into 3 squadrons of 4 troops each <i>Attached</i> 1 Major, Med. Dept. 3 Capts., or 1st Lieuts., Med. Dept. 1	1 Major 1 1st Lieut., squadron adjutant 4 troops <i>Attached</i> 1 Squadron Sergt. Major (from Hdqrs. Troop)	1 Captain 1 1st Lieut. 1 2nd Lieut. — 3 — 1 1st Sergt. 1 Mess Sergt. 1 Supply Sergt. 1 Stable Sergt. 5 Sergts. 8 Corpls. 2 Cooks 2 Horseshoers 1 Saddler 2 Buglers 10 Pvts. (1st Class) 36 Pvts. — 70 — (The President may add 10 Pvts. (1st Class) and 25 Pvts.— total, 35)	1 Captain, Regtl. Adjt. — 1 Regtl. Sergeant Major 3 Squadron Sergts. Major 1 1st Sergt. (Drum Major) 2 Color Sergts. 1 Mess Sergt. 1 Supply Sergt. 1 Stable Sergt. 1 Sergt. 2 Cooks 1 Horseshoer 1 Saddler 2 Pvts. (1st Class) 9 Pvts. 1 Band leader 1 Asst. Band Leader 1 Sergt. Bugler 2 Band Sergts. 4 Band Corpls. 2 Musicians, 1st Class 4 Musicians, 2nd Class 13 Musicians, 3rd Class — 54	1 Captain 1 1st Lieut. 2 2nd Lieuts. — 4 — 1 1st Sergt. 1 Mess Sergt. 1 Supply Sergt. 1 Stable Sergt. 2 Horseshoers 5 Sergts. 6 Corpls. 2 Cooks 1 Mechanic 1 Saddler 2 Buglers 12 Pvts. 1st Class 35 Pvts. — 70 — (The President may add 3 Sergts., 2 Corpls., 1 Mechanic, 1 Pvt. 1st Class, 14	1 Captain, Regtl. Supply Officer 2 2nd Lieuts. — 3 — 3 Regtl. Supply Sergts. 1 1st Sergt. 1 Mess Sergt. 1 Stable Sergt. 1 Mess Sergt. 1 Stable Sergt. 2 Horseshoers 1 Stable Sergt. 1 Corpl. 1 Cook 1 Horseshoer 1 Saddler 1 Wagoner for each authorized wagon of the field and combat train.

Chaplain		— (The President may add 2 Sergts, 5 Corpls., 1 Horseshoer, 5 Pvts. 1st Class, 18 Pvts.—total, 31)	Pvts.—total, 21)
----------	--	---	------------------

Transportation, orderlies, etc. To each Squadron Hdqrs., 6 or 7 riding horses and 2 orderlies; to each squadron; 292 riding horses, 1 wagon and 4 draft mules.

Composition of Field Artillery Units

[Pg 601]

Regiment	Battalion (Gun or Howitzer)	Battery (Gun or Howitzer)	Headquarters Company of Regt., of 2 battalions	Supply (1) Regt. of 2 Batlns.
Each	Each	Each		
1 Colonel 1 Lt. Colonel 1 Captain — 3 — 1 Hdqrs. Co., 1 Supply Co., And such number of guns and howitzer as the President may direct. <i>Attached</i> 1 Major, Med. Dept. 3 Capts. or 1st Lieuts., Med. Dept. 1 Chaplain	1 Major 1 Captain — 2 — Batteries as follows: Mountain artillery battalions and light artillery gun or howitzer battalions serving with the field artillery or Infantry divisions shall contain three batteries; horse artillery battalions and heavy field artillery gun or howitzer battalions shall contain two batteries.	1 Captain 2 1st Lieuts. 2 2nd Lieuts. — 5 — 1 1st Sergt. 1 Supply Sergt. 1 Stable Sergt. 1 Mess Sergt. 6 Sergts. 13 Corpls. 1 Chief Mechanic 1 Saddler 2 Horseshoers 1 Mechanic 2 Buglers 3 Cooks 22 Pvts., 1st Class 71 Pvts. — 125 — When no enlisted men of the Quartermaster Corps are attached for such positions there shall be added to each battery of mountain artillery: 1 Packmaster Sergt., 1st Class 1 Asst. Packmaster Sergt. 1 Cargador, Corpl. (The President may add 3 Sergts., 7	1 Captain 1 1st Lieut. — 2 — 1 Regtl. Sergt. Major 2 Batln. Sergts. Major 1 1st Sergt. 2 Color Sergts. 1 Mess Sergt. 1 Supply Sergt. 1 Stable Sergt. 2 Sergts. 9 Corpls. 1 Horseshoer 1 Saddler 1 Mechanic 3 Buglers 2 Cooks 5 Pvts. 1st Class 15 Pvts. 1 Band leader 1 Asst. Band leader 1 Sergt. Bugler 2 Band Sergts. 4 Band Corpls. 2 Musicians, 1st Class 4 Musicians, 2nd Class 13 Musicians, 3rd Class — 76 — When a regiment consists of three battalions there shall be added to Hdqrs. Co.: 1 Batln. Sergt. Major, 1 Sergt., 3 Corpls., 1 Bugler, 1 Pvt. 1st Class, 5 Pvts.—total, 12. When no enlisted men of the Quartermaster	1 Captain 1 1st Lieut. — 2 — 2 Regtl. Supply Sergts. 1 1st Sergt. 1 Mess Sergt. 1 Corpl. 1 Cook 1 Horseshoer 1 Saddler 2 Pvts. 1 Wagoner for each authorized wagon of the field train. When Regt. consists of 3 Batlns. there shall be added 1 2nd Lieut. (1), 1 Regtl. Supply Sergt., 1 Pvt., 1 Wagoner for each additional authorized wagon of the field train. (The President may add 1 Corpl., 1 Cook, 1 Horseshoer, 1 Saddler.—total, 4) Supply Co., of Regt. of

		Corpls., 1 Horseshoer, 2 Mechanics, 1 Bugler, 13 Pvts. 1st Class, 37 Pvts. —total, 64)	Corps are attached for such positions there shall be added to each mountain artillery Hdqrs. Co., 1 Packmaster Sergt., 1st Class 1 Asst. Packmaster, Sergt. 1 Cargador, Corpl. —total, 3. (The President may add 2 Sergts., 5 Corpls., 1 Horseshoer, 1 Mechanic, 1 Pvt. 1st Class, 6 Pvts. —total 16 to a regiment of 2 battalions; and to a regiment of 3 battalions 1 Sergt., 7 Corpls., 1 Horseshoer, 1 Mechanic, 2 Cooks, 2 Pvts. 1st Class, 7 Pvts.— total, 21)	3 Batlns. may have added, the same number as given above for Regt. of 2 Batlns.
--	--	--	--	--

Transportation, orderlies, etc. To Battery Hdqrs., 8 riding horses; to each Battery, 24 riding horses, 88 draft horses, 1 Battery wagon, 1 Store wagon, 8 Caissons and 4 Guns.

[Pg 602]

PART IX

[Pg 603]

MAP READING AND MILITARY SKETCHING

CHAPTER I

[Pg 604]

MAP READING

1859. Definition of map. A map is a representation on paper of a certain portion of the earth's surface.

A military map is one that shows the things which are of military importance, such as roads, streams, bridges, houses, depressions, and hills.

1860. Map reading. By map reading is meant the ability to get a clear idea of the ground represented by the map,—of being able to *visualize* the ground so represented.

For some unknown reason, military map reading is generally considered a very difficult matter to master, and the beginner, starting out with this idea, seemingly tries to find it difficult.

However, as a matter of fact, map reading is not difficult, if one goes about learning it in the right way,—that is, by first becoming familiar with scales, contours, conventional signs, and other things that go to make up map making.

Practice is most important in acquiring ability in map reading. Practice looking at maps and then *visualizing* the actual country represented on the map.

1861. Scales. In order that you may be able to tell the distance between any two points on a map, the map must be drawn to scale,—that is, it must be so drawn that a certain distance on the map, say, one inch, represents a certain distance on the ground, say, one mile. On such a map, then, two inches would represent two miles on the ground; three inches, three miles, and so on. Therefore, we may say—

The scale of a map is the ratio between actual distances on the ground and those between the same points as represented on the map.

1862. Methods of representing scales. There are three ways in which the scale of a map may be represented:

1st. By words and figures, as 3 inches = 1 mile; 1 inch = 200 feet.

2d. By Representative Fraction (abbreviated R. F.), which is a fraction whose numerator represents units of distance on the map and whose denominator, units of distance on the ground.

For example, R. F. = $\frac{1 \text{ inch (on map)}}{1 \text{ mile (on ground)}}$ which is equivalent to R. F. = $\frac{1}{63360}$, since 1 mile = 63,360 inches. So the expression, "R. F. $\frac{1}{63360}$ " on a map merely means that 1 inch on the map represents 63,360 inches (or 1 mile) on the ground. This fraction is usually written with a numerator 1, as above, no definite unit of inches or miles being specified in either the numerator or denominator. In this case the expression means that one unit of distance on the map equals as many of the same units on the ground as are in the denominator. Thus, $\frac{1}{63360}$ means that 1 inch on the map = 63,360 inches on the ground, 1 foot on the map = 63,360 feet on the ground; 1 yard on the map = 63,360 yards on the ground, etc.

[Pg 605]

3d. By Graphical Scale, that is, a drawn scale. A graphical scale is a line drawn on the map, divided into equal parts, each part being marked not with its actual length, but with the distance which it represents on the ground. Thus:

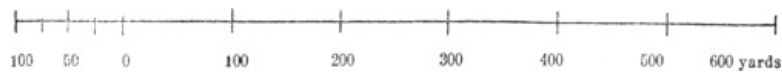

Fig. 1

For example, the distance from 0 to 50 represents fifty yards on the ground; the distance from 0 to 100, one hundred yards on the ground, etc.

If the above scale were applied to the road running from A to B in Fig. 2, it would show that the length of the road is 675 yards.

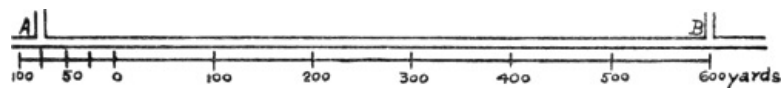

Fig. 2

1863. Construction of Scales. The following are the most usual problems that arise in connection with the construction of scales:

1. Having given the R. F. on a map, to find how many miles on the ground are represented by one inch on the map. Let us suppose that the R. F. is $\frac{1}{21120}$.

Solution

Now, as previously explained, $\frac{1}{21120}$ simply means that one inch on the map represents 21,120 inches on the ground. There are 63,360 inches in one mile. 21,120 goes into 63,360 three times—that is to say, 21,120 is $\frac{1}{3}$ of 63,360, and we, therefore, see from this that one inch on the map represents $\frac{1}{3}$ of a mile on the ground, and consequently it would take three inches on the map to represent one whole mile on the ground. So, we have this general rule: To find out how many miles one inch on the map represents on the ground, divide the denominator of the R. F. by 63,360.

2. Being given the R. F. to construct a graphical scale to read yards. Let us assume that $\frac{1}{21120}$ is the R. F. given—that is to say, one inch on the map represents 21,120 inches on the ground, but, as there are 36 inches in one yard, $21,120 \text{ inches} = \frac{21,120}{36} \text{ yds.} = 586.66 \text{ yds.}$ —that is, one inch on the map represents 586.66 yds. on the ground. Now, suppose about a 6-inch scale is desired. Since one inch on the map = 586.66 yards on the ground, 6 inches (map) = $586.66 \times 6 = 3,519.96$ yards (ground). In order to get as nearly a 6-inch scale as possible to represent even hundreds of yards, let us assume 3,500 yards to be the total number to be represented by the scale. The question then resolves itself into this: How many inches on the map are necessary to represent 3,500 yards on the ground. Since, as we have seen, one inch (map) = 586.66 yards (ground), as many inches are necessary to show 3,500 yards as 586.66 is contained in 3,500; or $\frac{3500}{586.66} = 5.96$ inches.

[Pg 606]

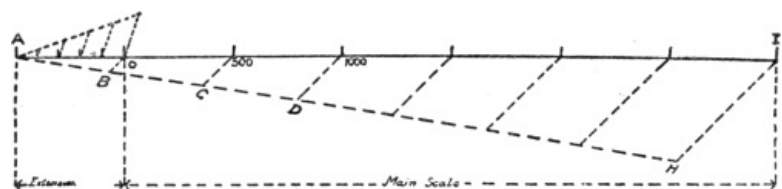

Now lay off with a scale of equal parts the distance A-I ([Figure 3](#)) = 5.96 inches (about 5 and $9\frac{1}{2}$ tenths), and divided it into 7 equal parts by the construction shown in figure, as follows: Draw a line A-H, making any convenient angle with A-I, and lay off 7 equal convenient lengths (A-B, B-C, C-D, etc.), so as to bring H about opposite to I. Join H and I and draw the intermediate lines through B, C, etc., parallel to H-I. These lines divide A-I into 7 equal parts, each 500 yards long. The left part, called the Extension, is similarly divided into 5 equal parts, each representing 100 yards.

3. To construct a scale for a map with no scale. In this case, measure the distance between any two definite points on the ground represented, by pacing or otherwise, and scale off the corresponding map distance. Then see how the distance thus measured corresponds with the distance on the map between the two points. For example, let us suppose that the distance on the ground between two given points is one mile and that the distance between the corresponding points on the map is $\frac{3}{4}$ inch. We would, therefore, see that $\frac{3}{4}$ inch on the map = one mile on the ground. Hence $\frac{1}{4}$ inch would represent $\frac{1}{3}$ of a mile, and 4-4, or one inch, would represent $4 \times \frac{1}{3} = \frac{4}{3} = 1\frac{1}{3}$ miles.

The R. F. is found as follows:

$$\text{R. F. } 1 \text{ inch}/(1\frac{1}{3} \text{ mile}) = 1 \text{ inch}/(63,360 \times 1\frac{1}{3} \text{ inches}) = \frac{1}{84480}.$$

From this a scale of yards is constructed as above (2).

4. To construct a graphical scale from a scale expressed in unfamiliar units. There remains one more problem, which occurs when there is a scale on the map in words and figures, but it is expressed in unfamiliar units, such as the meter (= 39.37 inches), strides of a man or horse, rate of travel of column, etc. If a noncommissioned officer should come into possession of such a map, it would be impossible for him to have a correct idea of the distances on the map. If the scale were in inches to miles or yards, he would estimate the distance between any two points on the map to be so many inches and at once know the corresponding distance on the ground in miles or yards. But suppose the scale found on the map to be one inch = 100 strides (ground), then estimates could not be intelligently made by one unfamiliar with the length of the stride used. However, suppose the stride was 60 inches long; we would then have this: Since 1 stride = 60 inches, 100 strides = 6,000 inches. But according to our supposition, 1 inch on the map = 100 strides on the ground; hence 1 inch on the map = 6,000 inches on the ground, and we have as our R. F., $\frac{1 \text{ inch (map)}}{6,000 \text{ inches (ground)}} = \frac{1}{6000}$. A graphical scale can now be constructed as in (2).

[Pg 607]

Problems in Scales

1864. The following problems should be solved to become familiar with the construction of scales:

Problem No. 1. The R. F. of a map is $\frac{1}{1000}$. Required: 1. The distance in miles shown by one inch on the map; 2. To construct a graphical scale of yards; also one to read miles.

Problem No. 2. A map has a graphical scale on which 1.5 inches reads 500 strides. 1. What is the R. F. of the map? 2. How many miles are represented by 1 inch?

Problem No. 3. The [Leavenworth map](#) in back of this book has a graphical scale and a measured distance of 1.25 inches reads 1,100 yards. Required: 1. The R. F. of the map; 2. Number of miles shown by 1 inch on the map.

Problem No. 4. 1. Construct a scale to read yards for a map of R. F. = $\frac{1}{21120}$. 2. How many inches represent 1 mile?

1865. Scaling distances from a map. There are four methods of scaling distances from maps:



Fig. 4

1. Apply a piece of straight edged paper to the distance between any two points, A and B, for instance, and mark the distance on the paper. Now, apply the paper to the graphical scale, ([Fig. 2, Par. 1862](#)), and read the number of yards on the main scale and add the number indicated on the extension. For example: 600 + 75 = 675 yards.

2. By taking the distance off with a pair of dividers and applying the dividers thus set to the graphical scale, the distance is read.

3. By use of an instrument called a map measurer, [Fig. 4](#), set the hand on the face to read zero, roll the small wheel over the distance; now roll the wheel in an opposite direction along the graphical scale, noting the number of yards passed over. Or, having rolled over the distance, note the number of inches on the dial and multiply this by the number of miles or other units per inch. A map measurer is valuable for use in solving map problems in patrolling, advance guard, outpost, etc.

valuable for use in solving map problems in patrolling, advance guard, outpost, etc.

4. Apply a scale of inches to the line to be measured, and multiply this distance by the number of miles per inch shown by the map.

1866. Contours. In order to show on a map a correct representation of ground, the depressions and elevations,—that is, the undulations,—must be represented. This is usually done by *contours*.

Con conversationally speaking, a *contour* is the outline of a figure or body, or the line or lines representing such an outline.

[Pg 608]

In connection with maps, the word *contour* is used in these two senses:

1. It is a projection on a horizontal (level) plane (that is, a map) of the line in which a horizontal plane cuts the surface of the ground. In other words, it is a line on a map which shows the route one might follow on the ground and walk on the absolute level. If, for example, you went half way up the side of a hill and, starting there, walked entirely around the hill, neither going up any higher nor down any lower, and you drew a line of the route you had followed, this line would be a *contour line* and its projection on a horizontal plane (map) would be a *contour*.

By imagining the surface of the ground being cut by a number of horizontal planes *that are the same distance apart*, and then projecting (shooting) on a horizontal plane (map) the lines so cut, the elevations and depressions on the ground are represented on the map.

It is important to remember that the imaginary horizontal planes cutting the surface of the ground must be the same distance apart. The distance between the planes is called the *contour interval*.

2. The word *contour* is also used in referring to *contour line*,—that is to say, it is used in referring to the line itself in which a horizontal plane cuts the surface of the ground as well as in referring to the projection of such line on a horizontal plane.

An excellent idea of what is meant by contours and contour-lines can be gotten from [Figs. 5](#) and [6](#). Let us suppose that formerly the island represented in [Figure 5](#) was entirely under water and that by a sudden disturbance the water of the lake fell until the island stood twenty feet above the water, and that later several other sudden falls of the water, twenty feet each time, occurred, until now the island stands 100 feet out of the lake, and at each of the twenty feet elevations a distinct water line is left. These water lines are perfect contour-lines measured from the surface of the lake as a reference (or datum) plane. [Figure 6](#) shows the contour-lines in [Figure 5](#) projected, or shot down, on a horizontal (level) surface. It will be observed that on the gentle slopes, such as F-H ([Fig. 5](#)), the contours (20, 40) are far apart. But on the steep slopes, as R-O, the contours (20, 40, 60, 80, 100) are close together. Hence, it is seen that contours far apart on a map indicate gentle slopes, and contours close together, steep slopes. It is also seen that the shape of the contours gives an accurate idea of the form of the island. The contours in [Fig. 6](#) give an exact representation not only of the general form of the island, the two peaks, O and B, the stream, M-N, the Saddle, M, the water shed from F to H, and steep bluff at K, but they also give the slopes of the ground at all points. From this we see that the slopes are directly proportional to the nearness of the contours—that is, the nearer the contours on a map are to one another, the steeper is the slope, and the farther the contours on a map are from one another, the gentler is the slope. A wide space between contours, therefore, represents level ground.

Fig. 5

[Pg 609]

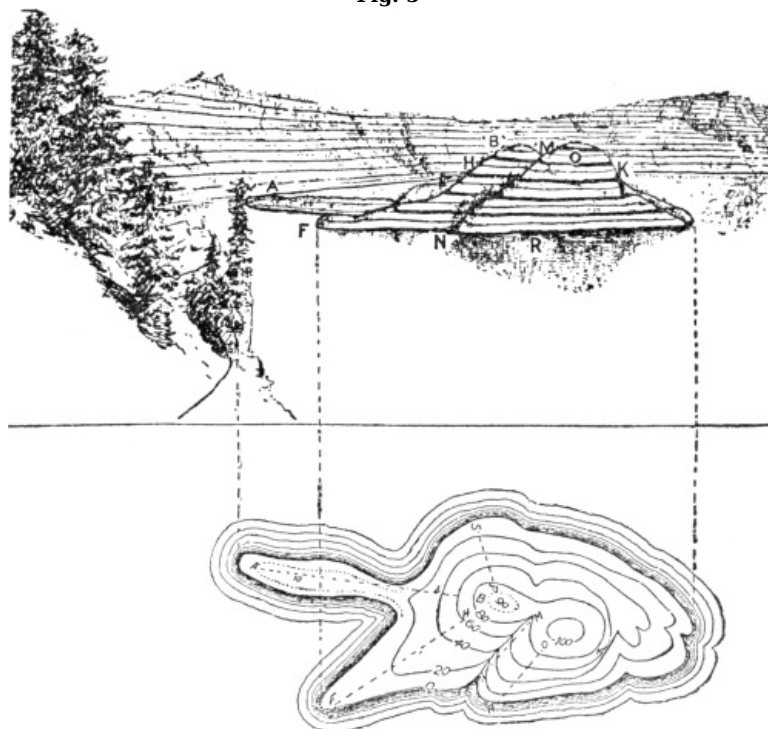

Fig. 6

The contours on maps are always numbered, the number of each showing its height above some plane called a datum plane. Thus in [Fig. 6](#) the contours are numbered from 0 to 100 using the surface of the lake as the datum plane.

The numbering shows at once the height of any point on a given contour and in addition shows the contour interval—in this case 20 feet.

Generally only every fifth contour is numbered.

The datum plane generally used in maps is mean sea level, hence the elevations indicated would be the heights above mean sea level.

The contours of a cone ([Fig. 7](#)) are circles of different sizes, one within another, and the same distance apart, because the slope of a cone is at all points the same.

The contours of a half sphere ([Fig. 8](#)), are a series of circles, far apart near the center (top), and near together at the outside (bottom), showing that the slope of a hemisphere varies at all points, being nearly flat on top and increasing in steepness toward the bottom.

[Pg 610]

The contours of a concave (hollowed out) cone ([Fig. 9](#)) are close together at the center (top) and far apart at the outside (bottom).

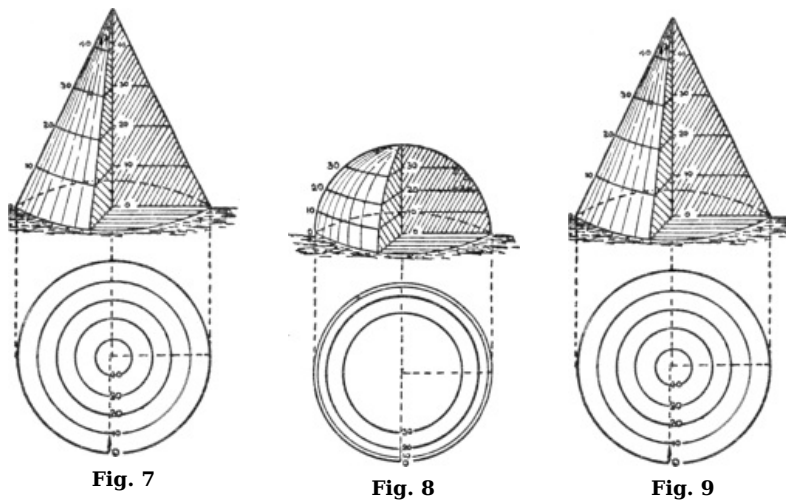

The following additional points about contours should be remembered:

(a) A Water Shed or Spur, along with rain water divides, flowing away from it on both sides, is indicated by the higher contours bulging out toward the lower ones (F-H, [Fig. 6](#)).

(b) A Water Course or Valley, along which rain falling on both sides of it joins in one stream, is indicated by the lower contours curving in toward the higher ones (M-N, [Fig. 6](#)).

(c) The contours of different heights which unite and become a single line, represent a vertical cliff (K, [Fig. 6](#)).

(d) Two contours which cross each other represent an overhanging cliff.

(e) A closed contour without another contour in it, represents either in elevation or a depression, depending on whether its reference number is greater or smaller than that of the outer contour. A hilltop is shown when the closed contour is higher than the contour next to it; a depression is shown when the closed contour is lower than the one next to it.

If the student will first examine the drainage system, as shown by the courses of the streams on the map, he can readily locate all the valleys, as the streams must flow through valleys. Knowing the valleys, the ridges or hills can easily be placed, even without reference to the numbers on the contours.

[Pg 611]

For example: On the [Elementary Map](#), Woods Creek flows north and York Creek flows south. They rise very close to each other, and the ground between the points at which they rise must be higher ground, sloping north on one side and south on the other, as the streams flow north and south, respectively (see the ridge running west from Twin Hills).

The course of Sandy Creek indicates a long valley, extending almost the entire length of the map. Meadow Creek follows another valley, and Deep Run another. When these streams happen to join other streams, the valleys must open into each other.

1867. Map Distances (or horizontal equivalents). The horizontal distance between contours on a map (called map distance, or M. D.; or horizontal equivalents or H. E.) is inversely proportional to the slope of the ground represented—that is to say, the greater the slope of the ground, the less is the horizontal distance between the contours; the less the slope of the ground represented, the greater is the horizontal distance between the contours.

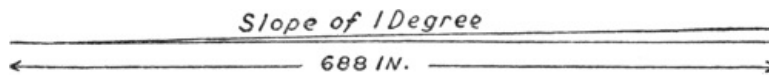

Fig. 10

Slope (degrees)	Rise (feet)	Horizontal Distance (inches)
1 deg.	1	688
2 deg.	1	$\frac{688}{2} = 344$
3 deg.	1	$\frac{688}{3} = 229$
4 deg.	1	$\frac{688}{4} = 172$
5 deg.	1	$\frac{688}{5} = 138$

It is a fact that 688 inches horizontally on a 1 degree slope gives a vertical rise of one foot; 1376 inches, two feet, 2064 inches, three feet, etc., from which we see that on a slope of 1 degree, 688 inches multiplied by vertical rises of 1 foot, 2 feet, 3 feet, etc., gives us the corresponding horizontal distance in inches. For example, if the contour interval (Vertical Interval, V. I.) of a map is 10 feet, then 688 inches \times 10 equals 6880 inches, gives the horizontal ground distance corresponding to a rise of 10 feet on a 1 degree slope. To reduce this horizontal ground distance to horizontal map distance, we would, for example, proceed as follows:

[Pg 612]

Let us assume the R. F. to be $\frac{1}{15840}$ —that is to say, 15,840 inches on the ground equals 1 inch on the map, consequently, 6880 inches on the ground equals $\frac{6880}{15840}$, equals .44 inch on the map. And in the case of 2 degrees, 3 degrees, etc., we would have:

M. D. for 2° = $\frac{6880}{15840 \times 2} = .22$ inch;

M. D. for 3° = $\frac{6880}{15840 \times 3} = .15$ inch, etc.

From the above, we have this rule:

To construct a scale of M. D. for a map, multiply 688 by the contour interval (in feet) and the R. F. of the map, and divide the results by 1, 2, 3, 4, etc., and then lay off these distances as shown in [Fig. 11, Par. 1867a](#).

FORMULA

M. D. (inches) = $\frac{688 \times \text{V. I. (feet)} \times \text{R. F.}}{\text{Degrees (1, 2, 3, 4, etc.)}}$

1867a. Scale of Map Distances (or, Scale of Slopes). On the [Elementary Map](#), below the scale of miles and scale of yards, is a scale similar to the following one:

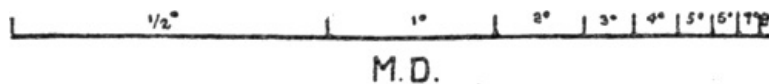

Fig. 11

The left-hand division is marked $\frac{1}{2}^\circ$; the next division (one-half as long) 1° ; the next division (one-half the length of the 1° division) 2° , and so on. The $\frac{1}{2}^\circ$ division means that where adjacent contours on the map are just that distance apart, the ground has a slope of $\frac{1}{2}$ a degree between these two contours, and slopes up toward the contour with the higher reference number; a space between adjacent contours equal to the 1° space shown on the scale means a 1° slope, and so on.

What is a slope of 1° ? By a slope of 1° we mean that the surface of the ground makes an angle of 1° with the horizontal (a level surface. See [Fig. 10, Par. 1867](#)). The student should find out the slope of some hill or street and thus get a concrete idea of what the different degrees of slope mean. A road having a 5° slope is very steep.

By means of this scale of M. D.'s on the map, the map reader can determine the slope of any portion of the ground represented, that is, as steep as $\frac{1}{2}^\circ$ or steeper. Ground having a slope of less than $\frac{1}{2}^\circ$ is practically level.

1868. Slopes. Slopes are usually given in one of three ways: 1st, in degrees; 2d, in percentages; 3d, in gradients (grades).

1st. A one degree slope means that the angle between the horizontal and the given line is 1 degree (1°). See [Fig. 10, Par. 1867](#).

2d. A slope is said to be 1, 2, 3, etc., per cent, when 100 units horizontally correspond to a rise of 1, 2, 3, etc., units vertically.

[Pg 613]

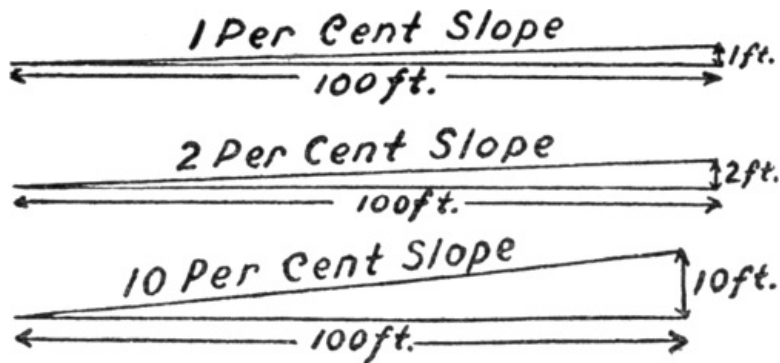

Fig. 12

3d. A slope is said to be one on one ($\frac{1}{1}$), two on three, ($\frac{2}{3}$), etc., when one unit horizontal corresponds to 1 vertical; three horizontal correspond to two vertical, etc. The numerator usually refers to the vertical distance, and the denominator to the horizontal distance.

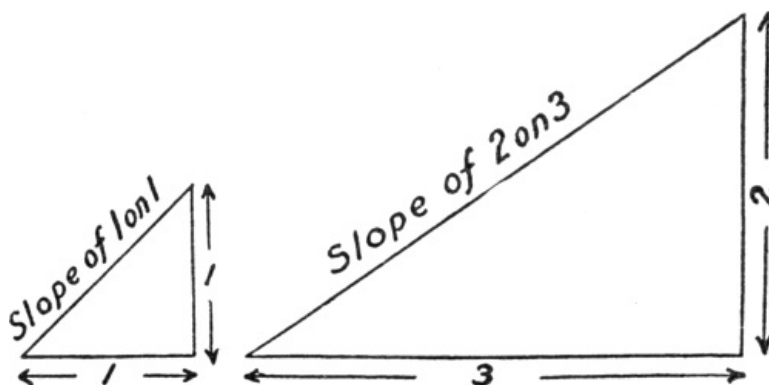

Fig. 13

Degrees of slope are usually used in military matters; percentages are often used for roads, almost always of railroads; gradients are used of steep slopes, and usually of dimensions of trenches.

1869. Effect of Slope on Movements

- 60 degrees or $\frac{7}{4}$ inaccessible for infantry;
- 45 degrees or $\frac{1}{1}$ difficult for infantry;
- 30 degrees or $\frac{4}{7}$ inaccessible for cavalry;
- 15 degrees or $\frac{1}{4}$ inaccessible for artillery;
- 5 degrees or $\frac{1}{12}$ accessible for wagons.

The normal system of scales prescribed for U. S. Army field sketches is as follows: For road sketches, 3 inches = 1 mile, vertical interval between contours (V. I.) = 20 ft.; for position sketches, 6 inches = 1 mile, V. I. = 10 ft.; for fortification sketches, 12 inches = 1 mile, V. I. = 5 ft. On this system any given length of M. D. corresponds to the same slope on each of the scales. For instance, .15 inch between contours represents a 5° slope on the 3-inch, 6-inch and 12-inch maps of the normal system. [Figure 11, Par. 1867a](#), gives the normal scale of M. D.'s for slopes up to 8 degrees. A scale of M. D.'s is usually printed on the margin of maps, near the geographical scale.

[Pg 614]

1870. Meridians. If you look along the upper left hand border of the [Elementary Map](#) (back of Manual), you will see two arrows, as shown in [Fig. 14](#), pointing towards the top of the map.



They are pointing in the direction that is north on the map. The arrow with a full barb points toward the north pole (the True North Pole) of the earth, and is called the True Meridian.

The arrow with but half a barb points toward what is known as the Magnetic Pole of the earth, and is called the Magnetic Meridian.

The Magnetic Pole is a point up in the arctic regions, near the geographical or True North Pole, which, on account of its magnetic qualities, attracts one end of all compass needles and causes them to point towards it, and as it is near the True North Pole, this serves to indicate the direction of north to a person using a compass.

Of course, the angle which the Magnetic needle makes with the True Meridian (called the Magnetic Declination) varies at different points on the earth. In some places it points east of the True Meridian and in others it points west of it.

It is important to know this relation because maps usually show the

True Meridian and an observer is generally supplied with a magnetic compass. [Fig. 15](#) shows the usual type of Box Compass. It has 4 cardinal points, N, E, S and W marked, as well as a circle graduated in degrees from zero to 360°, clockwise around the circle. To read the magnetic angle (called magnetic azimuth) of any point from the observer's position the north point of the compass circle is pointed toward the object and the angle indicated by the north end of the needle is read.

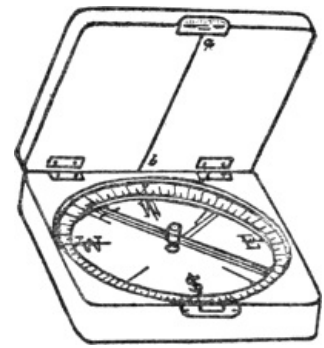

Fig. 15

[Pg 615]

You now know from the meridians, for example, in going from York to Oxford (see [Elementary Map](#)) that you travel north; from Boling to Salem you must travel south; going from Salem to York requires you to travel west; and from York to Salem you travel east. Suppose you are in command of a patrol at York and are told to go to Salem by the most direct line across country. You look at your map and see that Salem is exactly east of York. Next you take out your field compass ([Figure 15, Par. 1870](#)), raise the lid, hold the box level, allow the needle to settle and see in what direction the north end of the needle points (it would point toward Oxford). You then know the direction of north from York, and you can turn your right and go due east towards Salem.

Having once discovered the direction of north on the ground, you can go to any point shown on your map without other assistance. If you stand at York, facing north and refer to your map, you need no guide to tell you that Salem lies directly to your right; Oxford straight in front of you; Boling in a direction about halfway between the directions of Salem and Oxford, and so on.

1871. Determination of positions of points on map. If the distance, height and direction of a point on a map are known with respect to any other point, then the position of the first point is fully determined.

The scale of the map enables us to determine the distance; the contours, the height; and the time meridian, the direction.

Thus (see [map](#) in pocket at back of book), Pope Hill (sm') is 800 yards from Grant Hill (um') (using graphical scale), and it is 30 feet higher than Grant Hill, since it is on contour 870 and Grant Hill is on contour 840; Pope Hill is also due north of Grant Hill, that is, the north and south line through Grant Hill passes through Pope Hill. Therefore, the position of Pope Hill is fully determined with respect to Grant Hill.

Orientation

1872. In order that directions on the map and on the ground shall correspond, it is necessary for the map to be oriented, that is, the true meridian of the map must lie in the same direction as the true meridian through the observer's position on the ground, which is only another way of saying that the lines that run north and south on the map must run in the same direction as the lines north and south on the ground. Every road, stream or other feature on the map will then run in the same direction as the road, stream or other feature itself on the ground, and all the objects shown on the map can be quickly identified and picked out on the ground.

Methods of Orienting a Map

1st. By magnetic needle: If the map has a magnetic meridian marked on it as is on the [Leavenworth map](#) (in pocket at back of book), place the sighting line, a-b, of the compass ([Fig. 15](#)) on the magnetic meridian of the map and move the map around horizontally until the north end of the needle points toward the north of its circle, whereupon the map is oriented. If there is a true meridian on the map, but not a magnetic meridian, one may be constructed as follows, if the magnetic declination is known:

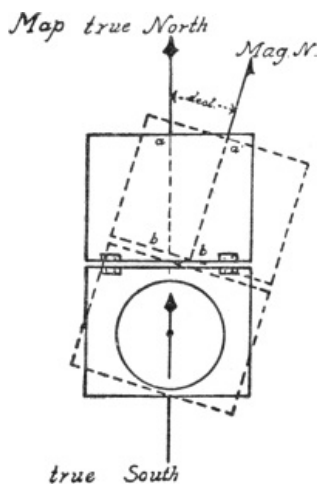

Fig. 16

([Figure 16](#)): Place the true meridian of the map directly under the magnetic needle of the compass and then move the compass box until the needle reads an angle equal to the magnetic declination. A line in extension of the sighting line a'-b' will be the magnetic-meridian. If the magnetic declination of the observer's position is not more than 4° or 5°, the orientation will be given closely enough for ordinary purposes by taking the true and magnetic meridians to be identical.

[Pg 616]

2d. If neither the magnetic nor the true meridian is on the map, but the observer's position on the ground is known: Move the map horizontally until the direction of some definite point on the ground is the same as its direction on the map; the map is then oriented. For example, suppose you are standing on the ground at 8, q k' (Fort Leavenworth Map), and can see the U. S. penitentiary off to the south. Hold the map in front of you and face toward the U. S. penitentiary, moving the map until the line joining 8 and the U. S. penitentiary (on the map) lies in the same direction as the line joining those two points on the ground. The map is now oriented.

Having learned to orient a map and to locate his position on the map, one should then practice moving over the ground and at the same time keeping his map oriented and noting each ground feature on the map as it is passed. This practice is of the greatest value in learning to read a map accurately and to estimate distances, directions and slopes correctly.

True Meridian

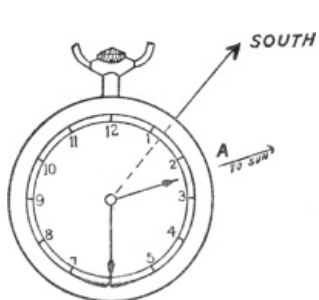

Fig. 17

1873. The position of the true meridian may be found as follows (Fig. 17): Point the hour hand of a watch toward the sun; the line joining the pivot and the point midway between the hour hand and XII on the dial, will point toward the south; that is to say, if the observer stands so as to face the sun and the XII on the dial, he will be looking south. To point the hour hand exactly at the sun, stick a pin as at (a) Fig. 17 and bring the hour hand into the shadow. At night, a line drawn toward the north star from the observer's position is approximately a true meridian.

[Pg 617]

The line joining the "pointers" of the Great Bear or Dipper, prolonged about five times its length passes nearly through the North Star, which can be recognized by its brilliancy.

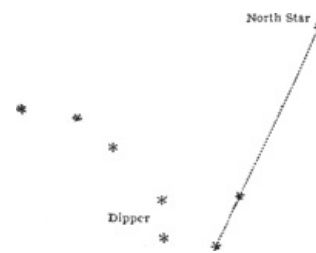

Fig. 18

1874. Conventional Signs. In order that the person using a map may be able to tell what are roads, houses, woods, etc., each of these features are represented by particular signs, called conventional signs. In other words, conventional signs are certain marks or symbols shown on a map to designate physical features of the terrain. (See diagram, Par. 1875 Plate I and II.) On the [Elementary Map](#) the conventional signs are all labeled with the name of what they represent. By examining this map the student can quickly learn to distinguish the conventional signs of most of the ordinary features shown on maps. These conventional signs are usually graphical representations of the ground features they represent, and, therefore, can usually be recognized without explanation.

For example, the roads on the [Elementary Map](#) can be easily distinguished. They are represented by parallel lines (====). The student should be able to trace out the route of the Valley Pike, the Chester Pike, the County Road, and the direct road from Salem to Boling.

Private or farm lanes, and unimproved roads are represented by broken lines (= = = =). Such a road or lane can be seen running from the Barton farm to the Chester Pike. Another lane runs from the Mills farm to the same Pike. The small crossmarks on the road lines indicate barbed wire fences; the round circles indicate smooth wire; the small, connected ovals (as shown around the cemetery) indicate stone walls, and the zigzag lines (as shown one mile south of Boling) represent wooden fences.

Near the center of the map, by the Chester Pike, is an orchard. The small circles, regularly placed, give the idea of trees planted in regular rows. Each circle does not indicate a tree, but the area covered by the small circles does indicate accurately the area covered by the orchard on the ground.

Just southwest of Boling a large woods (Boling Woods) is shown. Other clumps of woods, of varying extent, are indicated on the map.

The course of Sandy Creek can be readily traced, and the arrows placed along it, indicate the direction in which it flows. Its steep banks are indicated by successive dashes, termed *hachures*. A few trees are shown strung along its banks. Baker's Pond receives its water from the little creek which rises in the small clump of timber just south of the pond, and the hachures along the northern end represent the steep banks of a dam. Meadow Creek flows northeast from the dam and then northwest toward Oxford, joining Woods Creek just south of that town. York Creek rises in the woods $1\frac{1}{4}$ miles north of York, and flows south through York. It has a west branch which rises in the valleys south of Twin Hills.

[Pg 618]

A railroad is shown running southeast from Oxford to Salem. The hachures, unconnected at their outer extremities, indicate the fills or embankments over which the track runs. Notice the fills or embankments on which the railroad runs just northwest of Salem; near the crossing of Sandy Creek; north of Baker's Pond; and where it approaches the outskirts of Oxford. The hachures, connected along their outer extremities, represent the cut through which the railroad passes. There is only one railroad cut shown on the [Elementary Map](#)—about one-quarter of a mile northeast of Baker's Pond—where it cuts through the northern extremity of the long range of hills, starting just east of York. The wagon roads pass through numerous cuts—west of Twin Hills, northern end of Sandy Ridge, southeastern end of Long Ridge, and so on. The small T's along the

railroad and some of the wagon roads, indicate telegraph or telephone lines.

The conventional sign for a bridge is shown where the railroad crosses Sandy Creek on a trestle. Other bridges are shown at the points the wagon roads cross this creek. Houses or buildings are shown in Oxford, Salem, York and Boling. They are also shown in the case of a number of farms represented—Barton farm, Wells farm, Mason's, Brown's, Baker's and others. The houses shown in solid black are substantial structures of brick or stone; the buildings indicated by rectangular outlines are "out buildings," barns, sheds, etc.

[Plates I](#) and [II](#) give the Conventional Signs used on military maps and they should be thoroughly learned.

Trees		Streams	
Isolated	Orchard	Under 15' wide	
Forest	Pine	Fordable	
Palms	Bamboo	Unfordable	
Banana		Infantry	
Cultivated		Cavalry	
Grass	Ploughed	Artillery	
Corn	Rice	Sentry	
Vineyard	Cotton	Vidette	
Railroads		Hospital	
Single Track		Trench	
Double Track		Camp	
Electric		Obstacles	
Roads		Abatis	
Improved		Wire entanglement	
Unimproved		Palisades	
Trail		Demolitions	
Church		Depression	
Postoffice		Cliffs	
Waterworks		Ravine	
Fences		Fill	
Hedge		Cut	
Stone			
Wire barbed			
Wire smooth			

Plate I

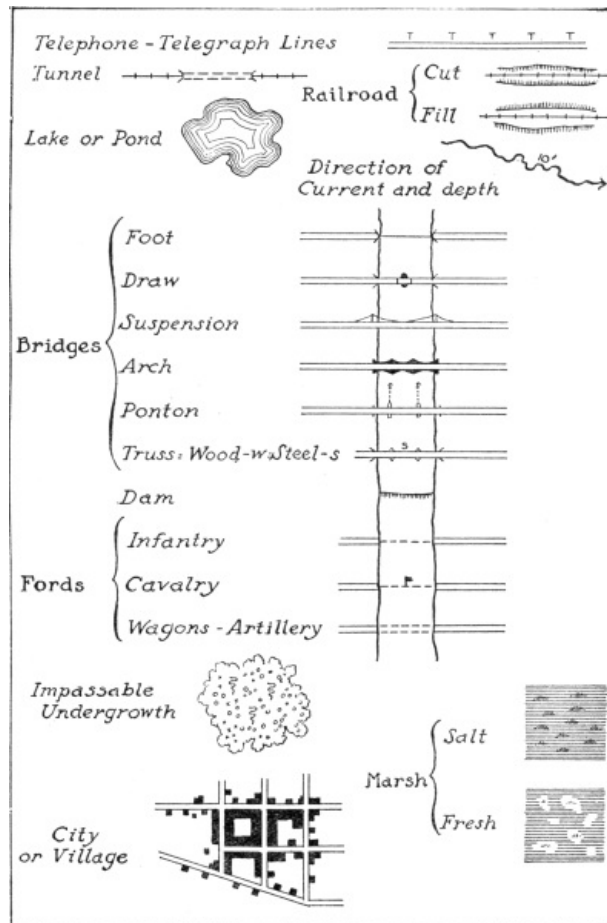

Plate II

In hasty sketching, in order to save time, instead of using the regulation Conventional Signs, very often simply the outline of the object, such as a wood, a vineyard, a lake, etc., is indicated, with the name of the object written within the outline, thus:

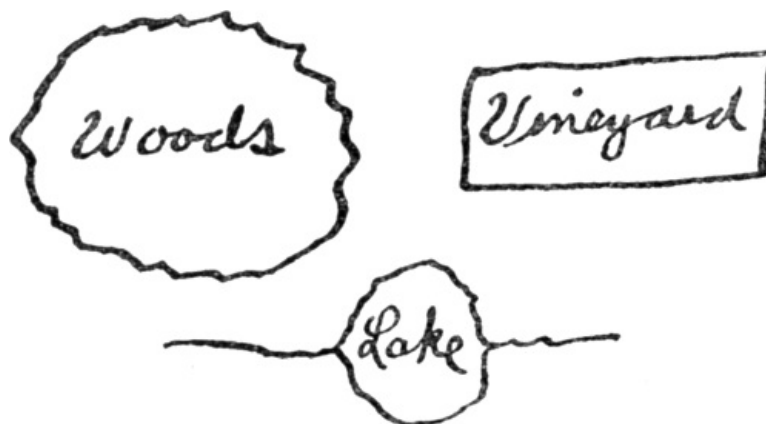

Fig. 19

Such means are used very frequently in rapid sketching, on account of the time that they save.

By reference to the [map of Fort Leavenworth](#), the meaning of all its symbols is at once evident from the names printed thereon; for example, that of a city, woods, roads, streams, railroad, etc.; where no Conventional Sign is used on any area, it is to be understood that any growths thereon are not high enough to furnish any cover. As an exercise, pick out from the map the following conventional signs: Unimproved road, cemetery, railroad track, hedge, wire fence, orchard, streams, lake. The numbers on the various road crossings have no equivalent on the ground, but are placed on the maps to facilitate description of routes, etc. Often the numbers at road crossings on other maps denote the elevation of these points.

[Pg 619]

Visibility

1875. The problem of visibility is based on the relations of contours and map distances previously discussed, and includes such matters as the determination of whether a point can or can not be seen from another; whether a certain line of march is concealed from the enemy; whether a particular area is seen from a given point.

On account of the necessary inaccuracy of all maps it is impossible to determine exactly how much ground is visible from any given point—that is, if a correct reading of the map shows a certain point to be just barely visible, then it would be unsafe to say positively that on the ground

this point could be seen or could not be seen. It is, however, of great importance for one to be able to determine at a glance, within about one contour interval, whether or not such and such a point is visible; or whether a given road is generally visible to a certain scout, etc. For this reason no effort is made to give an exact mathematical solution of problems in visibility further than would be useful in practical work with a map in the solution of map problems in patrolling.

In the solution of visibility problems, it is necessary that one should thoroughly understand the meaning of profiles and their construction. A profile is the line supposed to be cut from the surface of the earth by an imaginary vertical (up and down) plane. (See Fig. 21.) The representation of this line to scale on a sheet of paper is also called a profile. Figure 21 shows a profile on the line D—y (Figure 20) in which the horizontal scale is the same as that of the map (Figure 20) and the vertical scale is 1 inch = 40 feet. It is customary to draw a profile with a greater vertical than horizontal scale in order to make the slopes on the profile appear to the eye as they exist on the ground. Consequently, always note especially the vertical scale in examining any profile; the horizontal scale is usually that of the map from which the profile is taken.

[Pg 620]
[Pg 621]
[Pg 622]

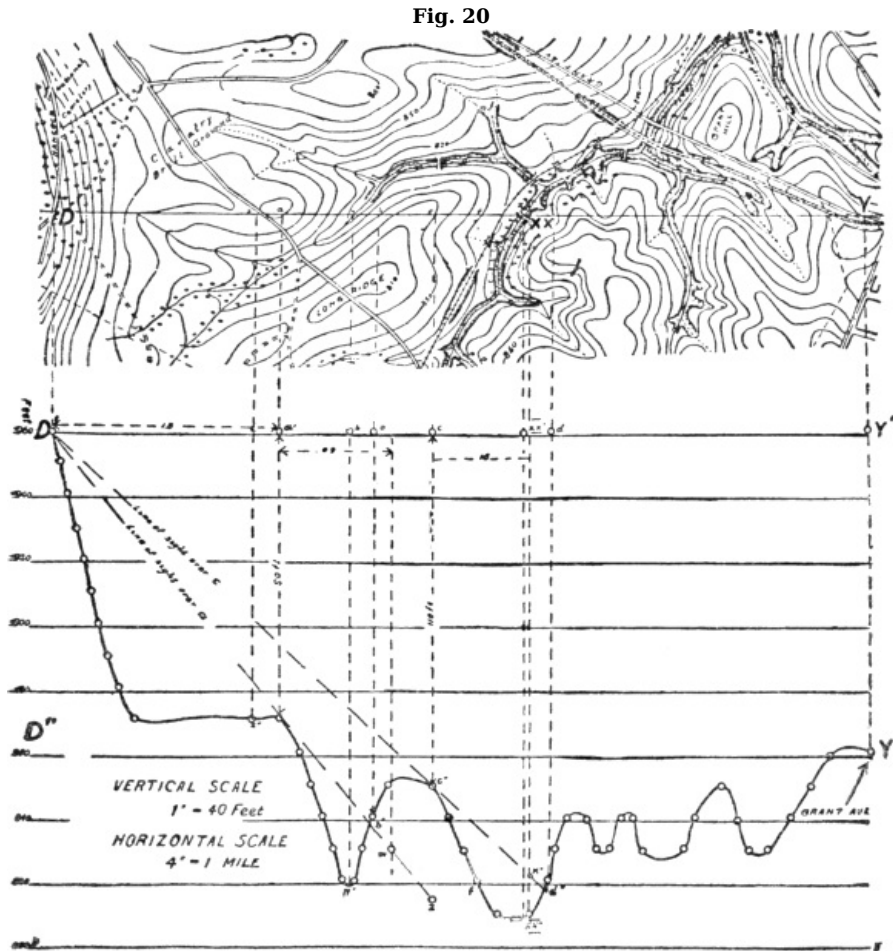

Fig. 21

A profile is constructed as follows: (Fig. 21): Draw a line D'—y' equal in length to D—y on the map. Lay off on this line from D' distances equal to the distances of the successive contours from D on the map. At each of these contour points erect a perpendicular equal to the elevation of this particular contour, as shown by the vertical scale (960, 940, 920, etc.) on the left. Join successively these verticals by a smooth curve, which is the required profile. Cross section paper with lines printed $\frac{1}{10}$ inch apart horizontally and vertically simplifies the work of construction, by avoiding the necessity of laying off each individual distance.

[Pg 623]

1876. Visibility Problem. To determine whether an observer with his eye at D can see the bridge at XX (Figure 20). By examining the profile it is seen that an observer, with his eye at D, looking along the line D—XX, can see the ground as far as (a) from (a) to (b), is hidden from view by the ridge at (a); (b) to (c) is visible; (c) to (d) is hidden by the ridge at (c). By thus drawing the profiles, the visibility of any point from a given point may be determined. The work may be much shortened by drawing the profile of only the observer's position (D) of the point in question, and of the probable obstructing points (a) and (c). It is evidently unnecessary to construct the profile from D to x, because the slope being concave shows that it does not form an obstruction.

The above method of determining visibility by means of a profile is valuable practice for learning slopes of ground, and the forms of the ground corresponding to different contour spacings.

Visibility of Areas

1877. To determine the area visible from a given point the same method is used. First mark off

as invisible all areas hidden by woods, buildings, high hills, and then test the doubtful points along lines such as D—XX, [Figure 20](#). With practice the noncommissioned officer can soon decide by inspection all except the very close cases.

This method is a rapid approximation of the solution shown in the profile. In general it will not be practicable to determine the visibility of a point by this method closer than to say the line of sight pierces the ground between two adjoining contours.

CHAPTER II

[Pg 624]

MILITARY SKETCHING

(While this chapter presents the principal features of military sketching in a simple, clear manner, attention is invited to the fact that the only way that any one who has never done any sketching can follow properly the statements made, is to do so with the instruments and the sketching material mentioned at hand. In fact, the only way to learn how to sketch is to *sketch*.)

1878. A military sketch is a rough map showing the features of the ground that are of military value.

Military sketching is the art of making such a military sketch.

Military sketches are of three kinds:

Position sketches, [Fig. 1](#);
Outpost sketches;
Road sketches.

All kinds of military sketches are intended to give a military commander detailed information of the ground to be operated over, when this is not given by the existing maps, or when there are no maps of the area.

The general methods of sketching are:

- (1) The location of points by intersection.
- (2) The location of points by resection.

1879. Location of points by intersection. To locate a point by intersection proceed as follows: Set up, level and orient the sketching board ([Par. 1872](#)), at A, [Fig. 1](#). The board is said to be oriented when the needle is parallel to the sides of the compass trough of the drawing board, [Fig. 2](#). (At every station the needle must have this position, so that every line on the sketch will be parallel to the corresponding line or direction on the ground.) Assume a point (A) on the paper, [Fig. 1](#) Y, in such a position that the ground to be sketched will fall on the sheet. Lay the ruler on the board and point it to the desired point (C), all the while keeping the edge of the ruler on the point (A), [Fig. 1](#) Y. Draw an indefinite line along the edge. Now move to (B), [Fig. 1](#) X, plotted on the map in (b), [Fig. 1](#) X, and having set up, leveled and oriented as at (A), [Fig. 1](#) Y, sight toward (C) as before. The intersection (crossing) of the two lines locates (C) on the sketch at (c), [Fig. 1](#) X.

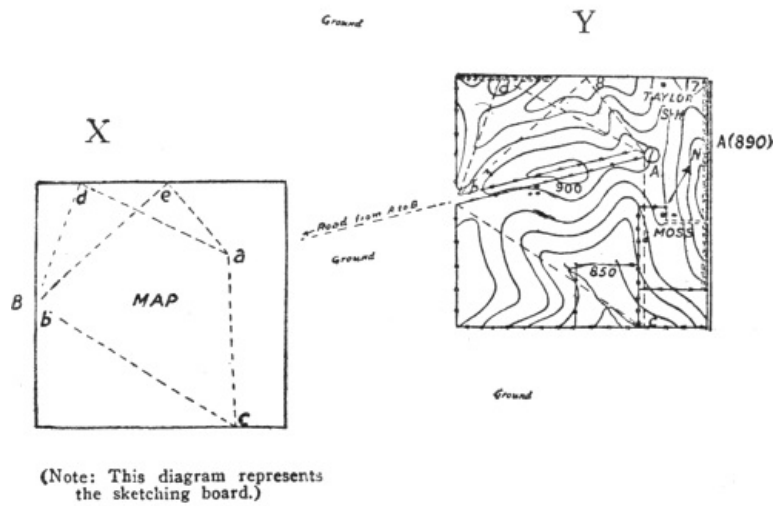

Fig. 1

1880. Locating points by resection. A sketcher at an unknown point may locate himself from two visible known points by setting up and orienting his sketching board. He then places his alidade (ruler) so that it points at one of the known points, keeping the edge of the alidade touching the corresponding point on the sketch. He then draws a ray (line) from the point toward his eye. He repeats the performance with the other visible known point and its location on the map. The point where the rays intersect is his location. This method is called *resection*. However, local attractions for the compass greatly affect this method.

1881. The location of points by traversing. To locate a point by traversing is done as follows: With the board set up, leveled and oriented at A, Fig. 1 Y, as above, draw a line in the direction of the desired point B, Fig. 1 X, and then move to B, counting strides, keeping record of them with a tally register, Fig. 3, if one is available. Set up the board at B, Fig. 1 X, and orient it by laying the ruler along the line (a)-(b), Fig. 1 X, and moving the board until the ruler is directed toward A, Fig. 1 Y, on the ground; or else orient by the needle as at A. With the scale of the sketcher's strides on the ruler, lay off the number of strides found from A, Fig. 1 Y, to B, Fig. 1 X, and mark the point (b), Fig. 1 X. Other points, such as C, D, etc., would be located in the same way.

[Pg 625]

1882. The determination of the heights of hills, shapes of the ground, etc., by contours. To draw in contours on a sketch, the following steps are necessary:

[Pg 626]

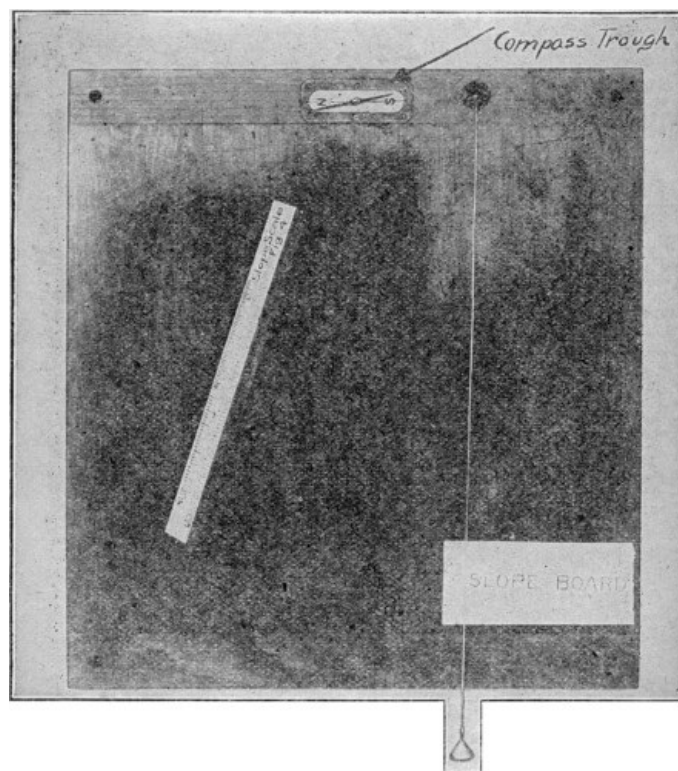

(a) From the known or assumed elevation of a located station as A, [Fig. 1 Y](#), (elevation 890), the elevations of all hill tops, stream junctures, stream sources, etc., are determined.

(b) Having found the elevations of these critical points the contours are put in by spacing them so as to show the slope of the ground along each line such as (a)-(b), (a)-(c), etc., [Fig. 1 Y](#), as these slopes actually are on the ground.



(Tally Register)—Fig. 3

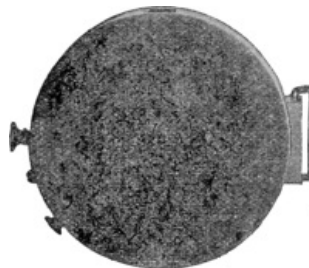

(Clinometer)—Fig. 4

[Pg 627]

To find the elevation of any point, say C (shown on sketch as c), proceed as follows:

Read the vertical angle with slope board, [Fig. 2](#), or with a clinometer, [Fig. 4](#). Suppose this is found to be 2 degrees; lay the scale of M. D.^[22] (ruler, [Fig. 2](#)) along (a)-(c), [Fig. 1 Y](#), and note the number of divisions of -2 degrees (minus 2°) between (a) and (c). Suppose there are found to be 5½ divisions; then, since each division is 10 feet, the total height of A above C is 55 feet (5½ × 10). C is therefore 835 ft. elev. which is written at (c), [Fig. 1 Y](#). Now looking at the ground along A-C, suppose you find it to be a very decided concave (hollowed out) slope, nearly flat at the bottom and steep at the top. There are to be placed in this space (a)-(c), [Fig. 1 Y](#), contours 890, 880, 870, 860 and 850, and they would be spaced close at the top and far apart near (c), [Fig. 1 Y](#), to give a true idea of the slope.

The above is the entire principle of contouring in making sketches and if thoroughly learned by careful repetition under different conditions, will enable the student to soon be able to carry the contours with the horizontal locations.

1883. In all maps that are to be contoured some plane, called the *datum plane*, must be used to which all contours are referred. This plane is usually mean sea level and the contours are numbered from this plane upward, all heights being elevations above mean sea level.

In a particular locality that is to be sketched there is generally some point the elevation of which is known. These points may be bench marks of a survey, elevation of a railroad station above sea level, etc. By using such points as the reference point for contours the proper elevations above sea level will be shown.

In case no point of known elevation is at hand the elevation of some point will have to be assumed and the contours referred to it.

Skill in contouring comes only with practice but by the use of expedients a fairly accurate contoured map can be made. In contouring an area the stream lines and ravines form a framework or skeleton on which the contours are hung more or less like a cobweb. These lines are accurately mapped and their slopes determined and the contours are then sketched in.

[Pg 628]

If the sketcher desires he may omit determining the slopes of the stream lines and instead determine the elevations of a number of critical points (points where the slope changes) in the area and then draw in the contours remembering that contours bulge downward on slopes and upward on streams lines and ravines.

If time permits both the slopes of the stream lines and the elevation of the critical points may be determined and the resulting sketch will gain in accuracy.

[Figs. 5, 6, 7, 8,](#) and [9](#) show these methods of determining and sketching in contours.

[Pg 629]

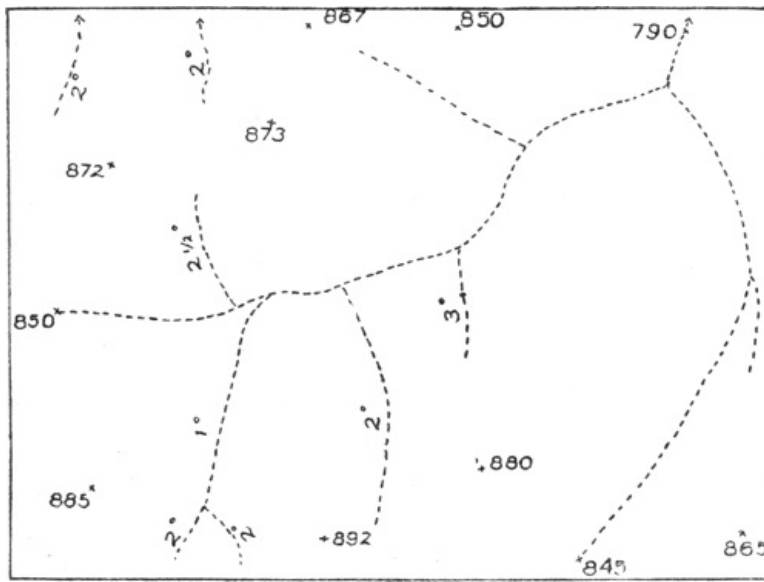

Fig. 5

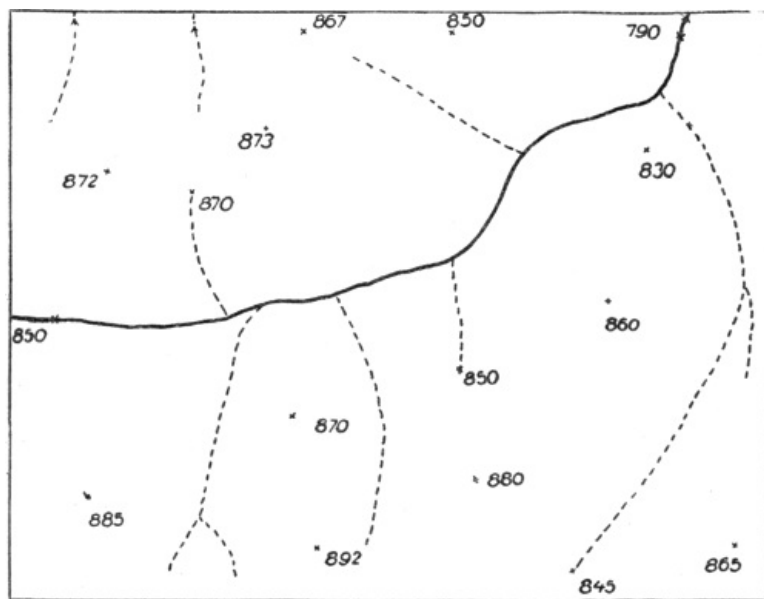

Fig. 6

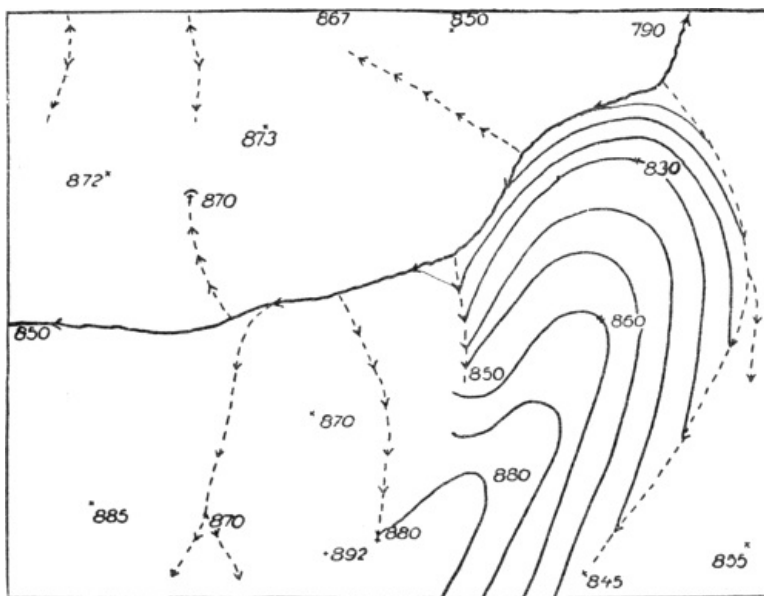

Fig. 7

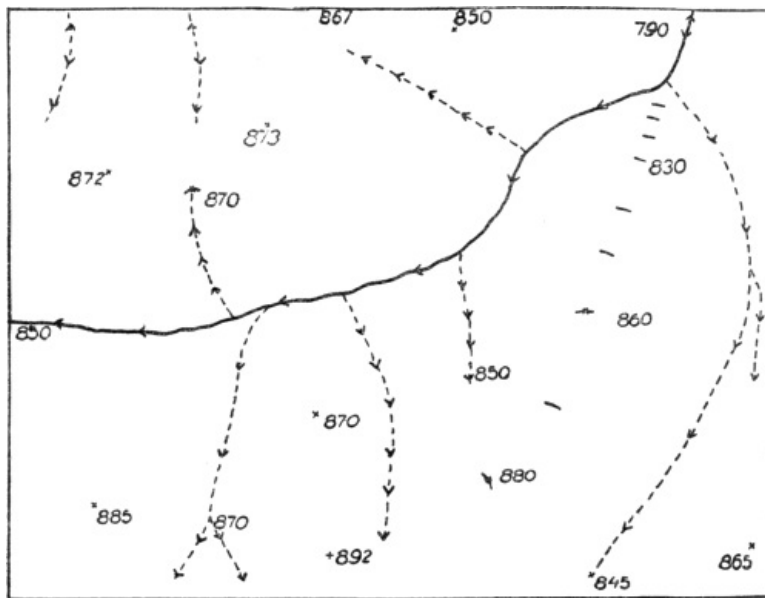

Fig. 8

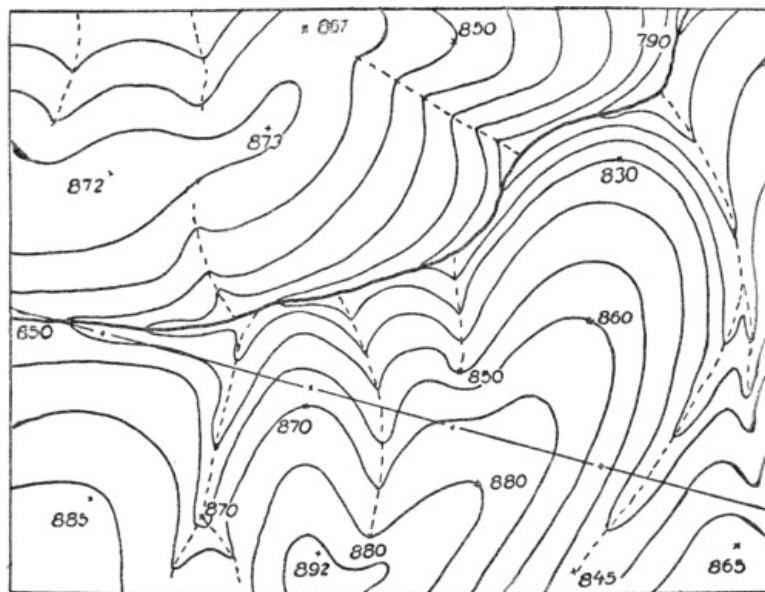

Fig. 9

1884. Form lines. It frequently happens that a sketch must be made very hastily and time will not permit of contouring. In this case form lines are used. These lines are exactly like contours except that the elevations and forms of the hills and depressions which they represent are estimated and the sketcher draws the form lines in to indicate the varying forms of the ground as he sees it.

1885. Scales. The Army Regulations prescribe a uniform system of scales and contour intervals for military maps, as follows:

Road sketches and extended positions; scale 3 inches to a mile, vertical (or contour) interval, 20 feet.

Position or outpost sketches; scale 6 inches to a mile, vertical (or contour) interval, 10 feet.

This uniform system is a great help in sketching as a given map distance, [Par. 1867a](#), represents the same degree of slope for both the 3 inch to the mile or the 6 inch to the mile scale. The map distances once learned can be applied to a map of either scale and this is of great value in sketching.

Construction of Working Scales

1886. Working scale. A *working scale* is a scale used in making a map. It may be a scale for paces or strides or revolutions of a wheel.

1887. Length of pace. The length of a man's pace at a natural walk is about 30 inches, varying somewhat in different men. Each man must determine his own length of pace by walking several times over a known distance. In doing this be sure to take a natural pace. When you know your length of pace you merely count your paces in going over a distance and a simple multiplication of paces by length of pace gives your distance in inches.

In going up and down slopes one's pace varies. On level ground careful pacing will give you distances correct to within 3% or less.

The following tables give length of pace on slopes of 5 degrees to 30 degrees, corresponding to a normal pace on a level of 30.4 inches:

Slopes	0°	5°	10°	15°	20°	25°	30°
Length of step ascending	30.4	27.6	24.4	22.1	19.7	17.8	15.0
Length of step descending	30.4	29.2	28.3	27.6	26.4	23.6	19.7

[Pg 631]

For the same person, the length of step decreases as he becomes tired. To overcome this, ascertain the length of pace when fresh and when tired and use the first scale in the morning and the latter in the afternoon.

The result of the shortening of the pace due to fatigue or going over a slope, is to make the map larger than it should be for a given scale. This is apparent when we consider that we take more paces in covering a given distance than we would were it on a horizontal plane and we were taking our normal pace.

In going up or down a slope of 3 or 4 we actually walk 5 units, but cover only 4 in a horizontal direction. Therefore, we must make allowance when pacing slopes.

In counting paces count each foot as it strikes. In counting strides count only 1 foot as it strikes. A stride is two paces.

[Pg 632]

In practice it has been found that the scale of strides is far more satisfactory than a scale of paces.

1888. How to make a scale of paces. Having determined the length of our pace, any one of the following three methods may be used in making a working scale:

1st method. The so-called "One thousand unit rule" method is as follows:

Multiply the R. F. (representative fraction) by the number of inches in the unit of measure multiplied by 1000; the result will be the length of line in inches necessary to show 1000 units.

For example, let us suppose that we desire a graphic scale showing 1000 yards, the scale of the map being 3 inches equal 1 mile:

Multiply $\frac{1}{21120}$ (R. F.) by 36 (36 inches in 1 yard, the unit of measure) by 1000,—that is,

$$\left(\frac{1}{21120}\right) \times 36 \times 1000 = \frac{36000}{21120} = 1.7046 \text{ inches.}$$

Therefore, a line or graphic scale 1.7 inches in length will represent 1000 yards.

If we desire a working scale of paces at 3 inches to the mile, and we have determined that our pace is 31 inches long, we would have $\left(\frac{1}{21120}\right) \times 31 \times 1000 = \frac{31000}{21120} = 1.467$ inches.

We can now lay off this distance and divide it into ten equal parts, and each will give us a 100-pace division.

2nd method. Lay off 100 yards; ascertain how many of your paces are necessary to cover this distance; multiply R. F. by 7,200,000, and divide by the number of paces you take in going 100 yards. The result will be the length of line in inches which will show 2000 of your paces.

3rd method. Construct a scale of convenient length, about 6 inches, as described in [Par. 1863](#), to read in the units you intend to measure your distance with (your stride, pace, stride of a horse, etc.), to the scale on which you intend to make your sketch.

For example, suppose your stride is 66 inches long (33 inch pace) and you wish to make a sketch on a scale of 3 inches = 1 mile. The R. F. of this scale is $\frac{3 \text{ inches}}{1 \text{ mile}} = \frac{3 \text{ inches}}{63360 \text{ inches}} = \frac{1}{21120}$. That is 1 inch on your sketch is to represent 21120 inches on the ground. As you intend to measure your ground distances by counting your strides of 66 inches length, 1 inch on the sketch will represent as many of your strides on the ground as 66 is contained into 21120 = 320 strides. For convenience in sketching you wish to make your scale about 6 inches long. Since 1 inch represents 320 strides, 6 inches will represent $6 \times 320 = 1,920$ strides. As this is an odd number, difficult to divide into convenient subdivisions of hundreds, fifties, etc., construct your scale to represent 2,000 strides, which will give it a length slightly in excess of 6 inches—6.25. Lay off this length and divide it into ten main divisions of 200 strides each, and subdivide these into 50 stride divisions as explained in [Par. 1862](#).

[Pg 633]

1889. Position sketching. The following are the instruments used in position sketching:

1. Drawing board with attached compass ([Fig. 2](#));
2. Loose ruler, on board ([Fig. 2](#));
3. Rough tripod or camera tripod;
4. Scale of M. D.'s (shown on ruler, [Fig. 2](#));

5. Scale of sketchers, strides or paces (at six inches to one mile), on ruler;
6. Clinometer (not necessary if board has slope board, [Fig. 6](#));
7. Scale of hundreds of yards shown on ruler;
8. Scale of paces.

Methods to be used

- (1) Select a base line,—that is, a central line $\frac{1}{4}$ to $\frac{1}{2}$ mile long in the area to be sketched. It should have at its ends some plainly marked objects, such as telegraph poles, trees, corners of buildings, etc., and from its ends, and intermediate points, a good view of the area should be possible. The base line selected should be capable of being measured.
- (2) Set up, level and orient the drawing board at one end of the base (A), [Fig. 1](#), Y, for example. Draw a meridian on the sheet parallel to the position of the magnetic needle. Assume a point (A), [Fig. 1](#), Y, corresponding to the ground point (A), 890, on the sheet, in such a position that the area to be sketched will lie on the sheet.
- (3) Sight at hilltops, stream junctures, stream heads, etc., to begin the locations of these points by intersection, labelling each ray so as to be able to identify it later.
- (4) Traverse to (b) and complete the locations by intersection as previously explained. If the base line is not accurately measured, the map will be correct within itself in all of its proportions, but its scale will not necessarily be the scale desired.
- (5) Draw the details of the country between A and B and in the vicinity of this line, using the conventional signs for roads, houses, etc.
- (6) The lines from station (b), [Fig. 1](#), X, to any of the other located points may now be used as a new base line to carry the work over additional area.
- (7) In case parts of the area are not visible from a base line, these parts are located by traversing as before explained.
- (8) Having learned by several repetitions the above steps, the sketcher will then combine contouring with his horizontal locations.

1890. Outpost sketching. The same instruments are used as in position sketching, and so are the methods the same, except that the sketcher cannot advance beyond the outpost line, toward the supposed position of the enemy. It is often possible to select a measurable base line well in rear of the line of observation,—for instance, along the line of resistance. Secondary base lines may then be taken on or near the line of observation, from the extremities of which additional base lines may be selected, if necessary, and points toward the enemy's position located by intersection. Details are sketched in as in position sketching. For obvious reasons, no traversing should be done along the line of observation.

[Pg 634]

1891. Road sketching. The following are the instruments used in road sketching:

1. Drawing board or sketching case;
2. Loose ruler;
3. Scale of strides, or paces, if made dismounted; scale of time trotting or walking, if mounted;
4. Scale of hundreds of yards, at three inches to 1 mile;
5. Scale of M. D.'s;
6. Slope board (if clinometer is not available).

Methods to be used

- (1) At station 1, [Fig. 10](#), orient the board as described in [par. 1872](#), holding the board in the hands, in front of the body of the sketcher, who faces toward station 2.

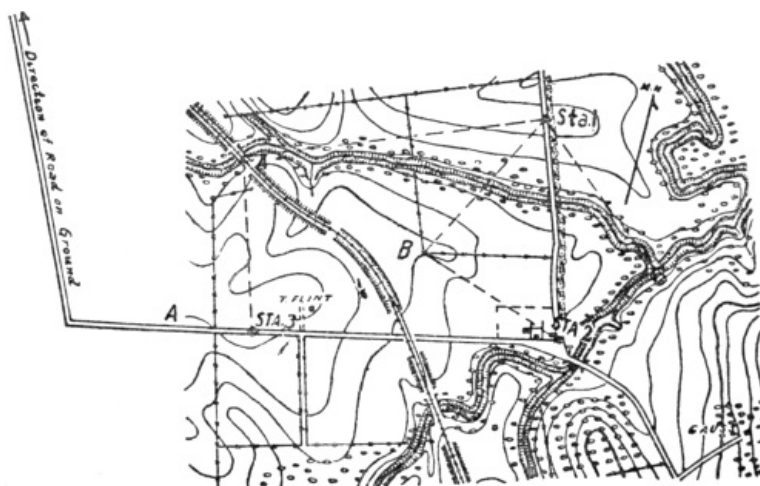

- (2) Important points in the vicinity, such as the railroad bridge, the stream juncture, hilltops, are sighted for intersections, lines drawn as shown and the sketcher traverses to station 2.
- (3) At station 2 he locates and draws in all details between station 1 and 2, to include about 300 yards on each side of the road.
- (4) The traverse is then continued forward as described for 1 and 2.
- (5) After some practice of horizontal sketching, as just described, the sketcher will be able to take up contouring in combination. The methods are as described in the paragraph on contouring. [Pg 635]
- (6) When the traverse runs off the paper as at A, [Fig. 10](#), the following method is followed: Reorient the board so that the road forward will lie across the long dimensions of the paper; draw a meridian parallel to the compass needle and assume a point on the new sheet corresponding to the last point (A) plotted on the first sheet.
- (7) On completion of the sketch various sections will be pasted together, so that all the meridians are parallel.

1892. Combined sketching. Let us suppose that we have the rectangle W, X, Y, Z, [Fig. 11](#), assigned to us to map and that we have been given four sketching parties, and that the locations and elevations of A and B have been previously determined by triangulation and are plotted to scale on our rectangle.

A logical step would be to carefully plot the line a' b', and then the lines c' c'' and c'' d.

If the area is densely wooded we run "line of level" by using the slope board or clinometer and by taking elevations at points arbitrarily selected. Our lines will look something like this:

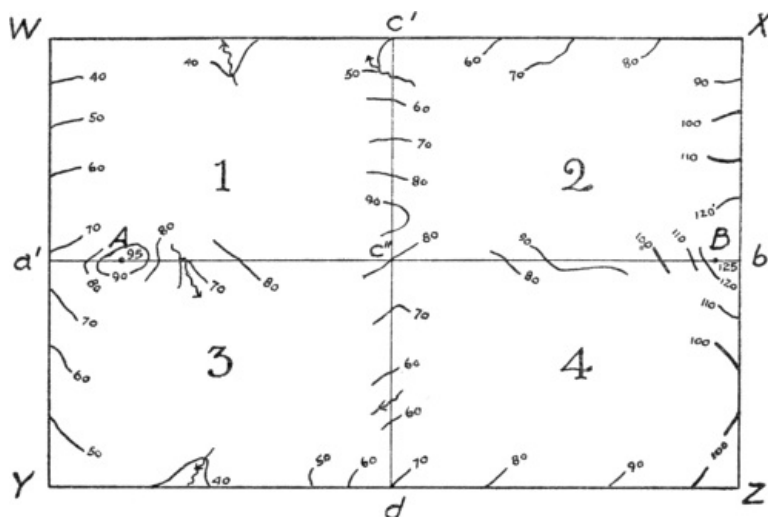

Fig. 11

Each party will be given its rectangle with the traverses sketched in. They will each then run similar traverses over the other two sides of their area and then fill in. In this manner the whole work is tied up to the original lines.

Another method

The line A B, [Fig. 12](#), is carefully plotted. Each of the four sketching parties has two sketching groups. One group of party No. 1 traverses line a' Y; then the other group of the party traverses the line a" y'. The first group of party of No. 2 accompanies them. The second group of party No. 2 traverses the line c" d, accompanied by the first group of party No. 3; the second group of party No. 3, and the first group of party No. 4 traverse b" z', and the second group of party No. 4 traverses b' Z. When the first group of party No. 1 arrives at Y, it traverses Y y'. The second group of party No. 1, arriving at y', cuts the sheet along traverse and gives the first group of party No. 2 the part which shows their area; and then traverses toward Y from y'. Upon meeting the first group of party No. 1, they join forces and proceed to fill in their area.

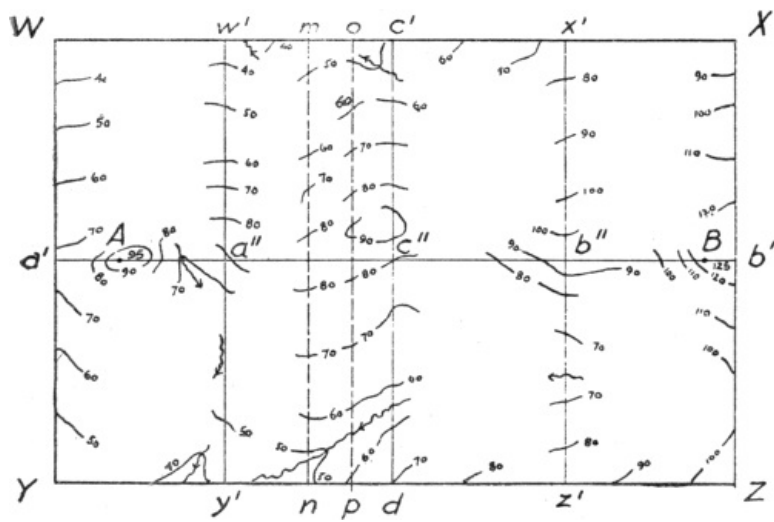

Fig. 12

In the same manner areas W X a' b' are filled in.

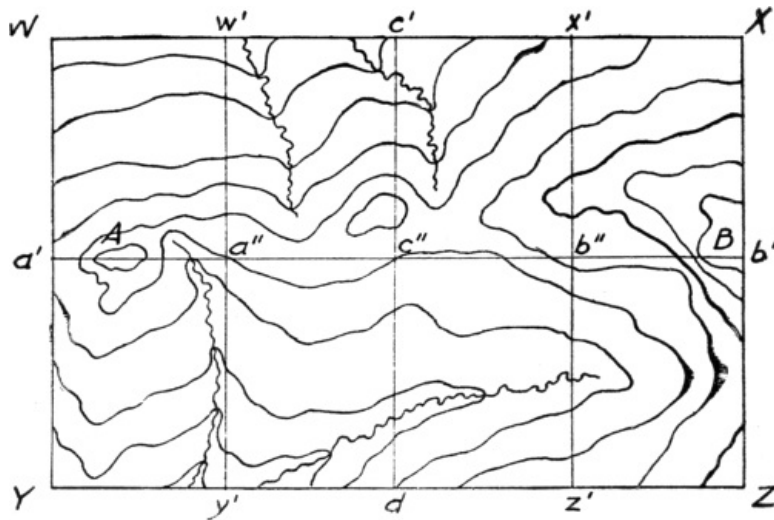

Fig. 13

The method described above is useful in working over country which is densely wooded, and in which a general view cannot be obtained, for example, in mapping jungles.

An additional article of the sketcher's equipment is a holder for his pencils, alidade, eraser, knife, pins, etc. This consists of a series of small pockets sewed on to a piece of canvas about 7 inches by 4 inches. This can be attached to the left breast of the sketcher's coat or shirt by means of two pins. In addition to keeping all of his implements in a handy place the holder prevents the loss of the several articles. Nothing is so discouraging to the sketcher as to look for his pencil, eraser, knife or even alidade and find that he has left it several hundred yards back where he sat down last to sketch in details. By using the holder the sketcher gets into the habit of replacing articles after they are used and consequently always has them with him when needed. These holders ready made can be obtained from the Secretary, Army Service Schools at Fort Leavenworth, Kansas.

In sketching a good quality of paper should always be used as erasures will be frequent. A specially prepared paper that has the appearance of oiled paper can be obtained commercially and is excellent for sketching in damp weather. It has considerable resistance to rain. Sheets of celluloid prepared for sketching are invaluable in sketching in the rain. These are a part of the equipment of the case of sketching instruments supplied battalions in the regular army. These sheets may be procured at most any dealers.

Points for Beginners to Remember

1893. 1. Always keep your pencils sharpened and have an eraser handy. No one but an expert can sketch with a dull pencil.
2. Use hard pencils when learning to sketch—4H to 6H—and go over your work afterwards with a softer pencil—2H.
3. Do not try to put down on your sketch a mass of small details that are too small to be shown on the scale at which you are sketching. For example, if you are making a sketch on a scale of 3 inches = 1 mile, do not try to show each house in a row of houses; simply indicate that there is a row of houses, by putting down several distinct conventional signs for houses in a row; nor should you try to show every little "cut" through which the road may run. Only use about one sign

to the inch of telegraph or telephone lines, for wire fences, etc.

4. When first practicing sketching only plot the route over which you walk, indicating it by a single line. When you can do this with facility, go back over one of these plotted routes and fill in the woods, houses, streams and the other large features.

5. The beginner should sketch the same ground several times over—at least three or four times. Practice alone will make perfect.

6. Always try to compare your finished sketch with an accurate map of the ground, if one is obtainable. Try to practice on ground of which you can obtain a map.

7. Make each course (the distance you go between points where the direction of your route changes) as long as possible.

8. Do not try to contour until you are expert at making a sketch showing all the flat details (roads, streams, woods, houses, etc.).

9. Never try to "sketch in" the contours until you have plotted the stream lines or the direction of the valleys, ravines, etc. The contours are fitted to or sketched around the drainage system; not the drainage system to the contours.

10. Always "size up" ground before you sketch it; that is, take a general view of it, noticing the drainage system (the direction in which the streams flow or ravines run), the prominent hills and ridges, the direction the roads run, etc.

11. Above all things, DON'T FAKE ANY PART OF YOUR MAP.

If the man using your map happens to strike the faked portion, he immediately condemns your whole map as incorrect. Every other part may be highly accurate, but your whole map is discredited because the user strikes the bad part first. You will naturally put little faith in the man who has told you something you know to be untrue. You will always suspect him. So it is with maps. Don't put down anything that you don't know to be correct. If any guess work is to be done, let the man using the map do it,—he knows that he is guessing and will be governed accordingly, but if you do the guessing, he doesn't know where the guessing begins and the accurate work leaves off. Don't fudge. Your name is on the map,—*don't have any questionable work hitched up to your name.*

FOOTNOTES:

[22] Sheets of working scales reading in paces, strides, minutes, etc, at a scale of 3 and 6 inches to the mile can be obtained at little cost from the Secretary, Army Service Schools, Fort Leavenworth, Kansas

INDEX

[Pg 639]

(The numbers refer to paragraphs)

A

	Par. No.
Abatis	1176
About face, how executed	105
1. About, 2. FACE, 3. Forward, 4. MARCH	229
About, turning by mounted officer	74
Abstract of clothing	905
Abstract record of memorandum receipts	901
Adjustment of fire	1428
Adjutant, formation of battalion	307 ; 308
Adjutant of general officer, post of	73
Adjutant's call	616 ; 693
Advance by crawling, etc.	261

ADVANCE BY RUSHES:	
Commands	259
Company as whole led by captain	260
Position, fire	293
When impossible for company to advance as a whole	258
ADVANCE GUARD:	
Commander with	542
Connecting files	584
Machine guns	553
Meeting engagement	542 ; 543
ADVANCE OF:	
Battalion acting as part of firing line	343
Company into an engagement	249 - 257
Firing line	346
ADVANCING:	
Improvised formations for	257
In succession of thin lines	255 ; 256
The attack	467 ; 471
Aerial mines	1200
Aides, post of	73
Aim, commands for	189
Aiming and sighting	1350
Aiming exercise	1368
Aiming point	1357
AIMING POINT:	
Announced before or after range	181
Designations, practice in repeating	201
Once designated not changed unless ordered	182
Use	284
ALIGNMENT:	
Battalion, rectifying	310 ; 312
Command of captains in battalion drill at command guide right (left)	301
Company	218
Definition	24
Deployed lines preserve general alignment	240
Dressing companies in formation of battalion in line	308
Placing left hand on hip	70
Position of captain and platoon leaders in prolongation	218
Position of captains in dressing companies in battalion drill	302
Preservation while marching	155
Rules for guides in close order	210 ; 211
Squad	154
AMMUNITION:	
Bandoleers	573
Combat train and major's responsibility for ammunition in belts	572
Destination of combat wagons when refilled	571
Expenditure of	432 ; 433
For company, husbanding and distribution	286
Issue before deployment of battalion	269
Issue upon deployment of battalion	331
Men not to be sent back from firing line for ammunition	574
Of dead and wounded	572
Rendezvous for each brigade	570
Replenishment of ammunition after engagement	575
Sent forward with reinforcements	574
Supply	360 ; 569 - 575
Thirty rounds in right pocket section	573
Amusement room	879
Appearance of objects in firing	1396

Appendices, Infantry Drill Regulations	696-710
Arm, disengaged, position at double time	and pp. 192 a b c d 121 (eighth)
Arm signals	92 ; 401
Arrangement of companies in battalion formation	297
Art of instruction on varied ground	933
Art of leadership	372
Art of war, definition	943
ARTILLERY:	
Action of infantry in case enemy has powerful artillery	418
Change of target by infantry warranted in case of flanking fire against artillery	424
Communication with firing line	402
Covering deployment of artillery in meeting engagement	541
Deployment of troops when exposed to hostile artillery	463
Effect on deployed infantry usually unimportant	345
Infantry against	597-600
Infantry passing through deployed artillery	470
In pursuit	494
In withdrawal from action	546
Part played in pursuit	491 ; 494
Supported by infantry	434-437
Use against machine guns	555
Use in delaying action	533
Withdrawal of attacking troops covered by artillery	489
ARTILLERY SUPPORTS:	
Charged only with protection of artillery	605
Detailing of supports	602
Formation and location in action	604
Formation on march	603
Purpose	601
Asphyxiating gases	1194
Asphyxiation, first aid	1478
ASSEMBLE FROM:	
Deployment	
Battalion	326
Company	248
Squad	173
Distances	159
Intervals	157
Platoon or squad columns	254
Assembled skirmishers not while marching to rear	173
ASSEMBLY:	
Arm signals	92
Call	693
Point indicated by company flag	95
AS SKIRMISHERS:	
Action of squad leaders at preparatory command	237
Deployment squad	170
Deployment in oblique direction	245
Deployment to flank or rear	246
From a column of twos or files	244
From platoon or squad column	253
Guide right (left or center) (being in column of squads)	244
Guide right (left or center) (being in line)	243
Rules for deployment	236-247
To increase or decrease intervals	172
'As you were'	64
AT EASE:	
Applicable to any marching formation	233

Extended order executed at ease	55 (b)
How executed	100
To march	233
With arms, executed as without arms	121 (fifth)
Athletic apparatus, company	880
ATTACK:	
Advancing	467-471
Battalion in	342-356
Company in	249-294
Deployment for	463-466
Enveloping	461; 462
Feint	502
Fire attack	258-261; 414-438
Flank	459-462
Fortifications	495-498
Frontal	457; 462
General principles	456-502
Holding attack	499-502
Machine guns	555
Opening fire	417
Pursuit	490-494
Range	344; 426
The charge	478-489
Unit, the battalion	342
ATTENTION:	
Command for	82
Drills at are disciplinary exercises	55 (a)
Forced at first word of command note of bugle or whistle	82
From parade rest	138
From rest and at ease resumed at order	121 (fifth)
From route step or at ease	233
Position of	99
At trail (command)	121 (sixth)
At will fire	190
Automatic alarms trenches	1192
Auxiliary aiming points	1431
B	
Back Step (backward march)	115
Bacon can, care of	1308
Balance position of left hand	122 (first)
Ballistic qualities of rifle	1410
BAND:	
In reviews	623; 624
Post of	71; 72; 299
Bandoleers ammunition in to be used first	573
Barricades	1185
Base company in advancing by rushes	348
Base, definition	25
Base squad in deployment	236-329; 243-245
BATTALION:	
Adjutant, formation of battalion	307; 308
Advance close in on enemy as much as possible before opening fire	344
Advance when part of firing line	343
Advance of firing line	346
Alignment rectifying	310; 311
Ammunition issue upon deployment	331

Arrangement of companies in battalion	297
Assembly from deployment	326
Attack principles	342-356
Attack unit, the	342
Base company in attack	329
Battalion a tactical unit	295
Battalion right (left)	318
Bayonets order to fix given by major	355; 361
Charge, the	356
Close on first (fourth) company	320
Close order drill	300-326
Column rectifying	312
Column of companies, first company squads right (left)	315
Column of squads first company, squads right (left)	316
Column of squads first (fourth) company, squads right (left) (from close column)	323
Column of squads first (fourth) company forward (from close line)	324
Column right (left)	317; 319
Combat principles	327-363
Command for guides repeated by captain	301
Commands repeated by captains	300
Consolidation to provide war strength organizations	55 (d)
Counter attack	363
Covering fire rushes made under	349
Defense	371
Defense opening fire	360
Deployment	
Avoidance of premature	332
Companies and detachments taking their places	334
Depth of	334
Designation of base company	329
Designation of companies	298
Dismissing	309
Division of battalion into support and firing line	335
Dressing battalion	310; 311
Dressing companies, action of guides	302
Dressing companies, position of captains	302
Extend on first (fourth) company	321
File closers, post in route marches	325
Fire, delayed opening as long as possible	344
Fire fight, where and when to begin, indicated by major	341
Fire to be directed against hostile infantry	345
Firing line:	
Advance	346
Companies to be kept closed in on center	354
Placing entire battalion or regiments into	339
Fix bayonets, ordered by major	355
Flanks, protection	330
Flank units to begin rush	348
Formations	307; 308
Front occupied by	334-339
Guides, action when companies are dressed	302
Guides, command for, repeated by captains	301
Hostile infantry target	345
Inspection	650-654
Intervals between battalions on firing line	465
Largest unit executing movement at command of the commander	88
Loading and firing	306
Mass formations	320
Major:	
Apportions target	340
Duties and responsibilities	295
Gives orders to charge	356
Gives order to fix bayonet	355; 361
His order making disposition of battalion for combat	329
Indicates where or when fire fight begins	341
Locates trenches and obstacles	358
Post during attack	352
Post in route march	325
Reënforces firing line (See " Battalion)	

Commander")	359
Movements executed as in school of the company	325
Movements executed as in school of soldier, squad	
and company	303 ; 304
Movements explained for four companies	296
Musicians repeat signals to charge	356
Musicians repeat signal to fix bayonet	355
Muster	655 -657
On right (left) into line	313
Opening fire on defense	360
Order of companies	297
Parade	636
Plate showing formations	300
Positions of captains in dressing companies	302
Post of band and other special units	299
Post of major during attack	352
Reconnaissance	330
Rectifying column	312
Reënforcing firing line, two methods	354
Reënforcements size	353
Repetition of command by captains	300
Review	631 -633
Right (left)	318
Right (left) (center) dress	310 ; 311
Right front (left) into line (from column of squads	
or companies)	314
Right front into line (from close column)	322
Rushes:	
Advance made under covering fire	349
Begin by flank company	348
Prearranged methods prohibited	351
Subsequent to advancing	350
Rushing units, size	346 ; 347
School of	295
Simultaneous movements by companies or	
platoons	305
Size of reënforcements	353
Staff officers	579
Support:	
Battalion acting alone in defense	362
None at beginning	339
Position	337
Size	336
To cover withdrawal	362
Tactical unit best suited for defense	357
Target, apportioned by major	340
Target, hostile infantry	345
Trenches located by major	358
Withdrawal covered by support	362
 BATTALION COMMANDERS:	
Duty regarding reconnaissance	412 -413
Equipped with different tone of whistle	83
Responsibility regarding ammunition	570
Signal to rear when ready to charge	480
See " Major " under " Battalion "	
 Battalion drill	300 -363
 Battalion inspection	650 -654
 Battalion parade	636
 Battalion staff officers, training in patrolling and reconnaissance	579
 BATTLE:	
Integrity of squads in	151
Separated officers and others placing themselves under order of nearest higher commander	390 ; 391
 Battlefields, bugle signals used on	90
 Battle order	392
 Battle sight	26 ; 1352 (c)

BAYONET:	
Charge in combat	356
Confidence in	485
Fixing	142
Habitually not fixed	121 (fourth)
Order to fix in combat given by major	355-361
Position at charge	144
Unfixing	143
When fixed in combat	355; 361; 590
Beaten zone	1413
Bite of dog	1480
Bite of snake	1480
Blank cartridges, use	273
Bleeding, first aid	1481
Books and records, company	887-909
Bombs and grenades	1197-1199
Bombs from air craft	1202
Bore of rifle, care	1322-1324; 1328; 1330
Bridges	1111-1125
BRIGADE:	
Commander, action in deployment	440
Review	628; 629
Broken bones	1483
Bruises, first aid	1487
Brush work, field engineering	1117
Bugle calls, explanation	692-695
BUGLE SIGNALS:	
Communication between firing line and rear	401
Those used on and off battlefields	90
Bunks, camping	1251
Burning clothes	1486
Burns, first aid	1485
By platoon (squad, etc.), from right (left) rush	259
"By the numbers"	122 (fifth)
By the right (left) flank, how executed	117
By the right (left) flank in forming skirmish line	237

C

CADENCE OF:	
Manual of arms	122 (fourth)
Marching	108
CALLS:	
Alarm	694
Formation	693
Service	695
Warning	692
CAMPS:	
Camping on fordable stream	1237
Desirable sites	1231
Form and dimensions of camps	1233
Making camp	1234
Making tent poles and pegs fast in loose soil	1239

Parade ground	1236
Retreat in camp	1235
Sanitation. See " Camp Sanitation "	
Selection of site	1230
Trees in camp	1240
Undesirable sites	1232
Windstorms	1238
See " Camp Sanitation "	
CAMP SANITATION:	
Avoiding old camp sites	1249
Bunks	1251
Camp expedients	1242
Canteen, care	1311
Changing camp site	1250
Definition	1241
Drainage	1248
Incinerators	1247
Kitchens	1245
Kitchen pits	1246
Latrines	1243
Rules of sanitation	1254
Urinal tubs	1244
Water	1253
Wood	1252
Your camp, your home	1255
CAPTAIN:	
Directs the fire	285 ; 286
Duties, etc.	868 ; 871
Indicates point on which base squad marches in deployment	238
Leads depleted company as platoon	209
Leads company as whole in rushes	260
Position at alignment	218 ; 302
Post during firings	269 ; 306
Responsible for instruction	202
CARE OF:	
Clothing	1277
Equipment	1276
Feet	1229
Rifle	1321
Shoes	1292
Cartridges not to be carried in piece	121 (first)
Cased colors, defined	659
Cat and mouse contest	1089
CAVALRY:	
Infantry against	591 -596
In pursuit	494
In withdrawal from action	546
Patrols	411
CEASE FIRING:	
Bugle signal for	90
How executed	194
Krag rifle	705
Center company, defined	298
Center, definition	27
Center of impact	1412
CEREMONIES:	
Battalion parade	636
Battalion review	631
Escorts of—	
Funeral	640 -645
Honor	639
The Color	637 -639
Formation of battalion	308

General rules	614-616
Mounted enlisted men formed into detachment	76
Parades, general rules	634 ; 635
Post of dismounted noncommissioned staff officers	77
Reviews, general rules	617-630
Ceremonies and drills at attention teach precision, etc.	55 (a)
CHALLENGING ON:	
Guard	1746
Outpost	1103
Chancroid	1466
Change elevation; signal for	92
CHANGE OF DIRECTION:	
Battalion	317-319
Company	219 ; 223 ; 224
Partial	67
Squad	164 ; 165
Change step, how executed	119
CHARGE, THE:	
Additional force for pursuit	483
Avoiding too dense a mass	481
Battalion commanders signal commanders of line	
when ready to charge	480
Bayonet, confidence in ability to use	485
Charging without authority from rear	484
Counter attack, preparations to meet	487
Fire superiority, what it accomplishes	478
Line to be strengthened by prolongations	482
Not to be made without sufficient troops	481
Premature charges to be avoided	484
Psychological moment for charge determined by	
tactical instinct	478
Pursuing fire	486
Pursuing troops	487
Pursuit, disordered units not to participate in	486
Reorganization of charging line	487
Reserves give impetus to charge	481
Steps to be taken in case of temporary set back	488
Steps to be taken if attack is abandoned	489
Strength of charging line	449
To be made simultaneously	480
To be made with approval of commander of attacking	
line	480
When and distance over which charge should be made	479
Without fire preparation	497
Charge bayonet	144
Charges, preferring	882
Cheerfulness, factor in training	930
Cheveaux de frise	1179 ; 1189
Chiggers	1488
Choking, first aid	1489
"Chop-chop" signal	863
Clap	1466
Classes of firing	278-280
Clearness in instruction	922
CLIP FIRE:	
How executed	192
Krag rifle	704
Use	280
Clock system of target designation	1446 ; 1447

Clock system of wind designation	1391
Close on first (fourth) company	320
CLOSE ORDER:	
Advantage of formation	539
Battalion	300 ; 326
Company	210
Double rank, habitual formation	70
Firings in	269
Necessity for	379
Close packs	648
Close range	275
Close ranks	648
Cloth equipment, care	1301
Clothing, care of	1277
Cohesion and order in combat	376
Cold, effect on shooting	1397
COLOR:	
Escort of	637 ; 638
Manual of	670
Receiving	667 - 669
Regimental saluting	622
Saluting in reviews	618
With reserve in battle	665
See " The Color "	
COLOR COMPANY:	
Defined	663
Receiving the colors	668
COLOR GUARD:	
Carrying of color	661
Composition	661
Escorting color to office or quarters of colonel	670
Formation and marching	662
In battle joins reserve	665
Loadings and firings	666
Manual of the color	670
Manual of arms	660
Movements executed	666
Post in various formations	664
Receiving the color	667 - 669
Remains with color company	663
Colors and standards	1575
Column, definition	28
Column half right (left)	67
Columns of companies to form successively to right or left	315
Column of squads, first (fourth) company forward (from close line)	324
Column of squads, first (fourth) company, squads right (from close column)	323
Column of squads, first company, squads right (left)	316
Column of squads, habitual column of route	233 ; 276
Column of subdivisions, full distance defined	69
Column, rectifying (battalion)	312
Column, right (left) (battalion)	317 ; 319
Column, right (company)	224

COMBAT EXERCISES:	
Definition	55 (d)
Effective method of conducting	371
Explained	1408
To be conducted under assumed tactical situations	370
To be followed by brief drill at attention	55 (d)
Combat, modern, demands upon infantry	365
Combats offering no chance of valuable results to be avoided	374
Combat patrols to protect flanks of company acting alone	268
Combat practice	1404
COMBAT PRINCIPLES:	
Battalion	327
Summary	550
Combat reconnaissance	403
Combat tactics, general	364
Combined sights	1430
Combined sketching	1892
Commander of the guard	1603
Commanding officer accountable for training	51
Commanding officer, guard duty	1591
COMMANDS:	
Battalion and higher commanders repeat commands of superiors	88
Battalion largest unit executing movement at command of its commander	88
Definition	86
Facing troops and avoiding indifference when giving commands	89
For guides, repeated by captains at battalion drill	301
How given	86; 89
Loading and firing	179
Of executions	87
Preparatory	57; 87
Repetition by:	
Battalion and higher commanders	88
Captains at battalion drill	300
Leaders of subdivisions when necessary	83
Platoon leaders and platoon drill	214
Use in battalion combat	328
When used	80
Commander's post in fight	383
Commence firing, bugle signal for	90
Common tents	688; 690
Communication between firing line and reserve	96
Communicating trenches	1157
Communication, how maintained, etc.	398-402
Communication in fire control and direction	1447 (b)
COMPANY:	
Abstract of clothing	905
Abstract record of memorandum receipts	901
Acting alone	267; 268
Arrangement in battalion formation	297; 614
Arrangement of men according to height	203
Athletic apparatus	880
Base	329-348
Books and records	887-909

Captain, duties etc.	868 ; 871
Center	298
Certain movements executed by company and platoons as prescribed in school of the Soldier and the squad	208
Close order drill	210
Column right (being in column of squads)	224
Companies to be consolidated to provide war strength organizations	55 (a)
Company attention, from route step or at ease	233
Company fund book	892
Company return	908
Company musicians carry company flags	402
Company right	219
Complete equipment carried into action	382
Completion of task, rejoining command after	390
Contentment and harmony	877
Correspondence book	893
Delinquency record	895
Depleted company led as platoon	209
Deployment as skirmishers	241 ; 243 ; 244
Deployment in oblique direction	245
Descriptive card of animals	898
Descriptive list	897
Designation in battalion formation	297
Devolution of work and responsibility	869
Division into platoons	204
Division into squads	205
Document file	894
Dressing	218
Drill	202
Duty roster	890
Establishing outpost	1080
Extended order drill	236
Files of orders	891
First Sergeant duties	873
First sergeant's report when company is formed	215
Flags	94 ; 95 ; 401
Formations in single rank	216
Formed in double rank	203
Forms of company punishment	883
Half right	67 ; 219
Inspection	646 - 649
Inspections, object of	88
Instruction. See " Training and instruction "	
In support	262 - 266
Largest unit executing extended order	55 (b) ; 328
Library and amusement room	879
Lieutenants, duties, etc.	870 ; 871
Lieutenants taking post when company is formed	215
Memorandum receipts	900
Mess	878
Morning report	888
Muster	655 - 657
Noncommissioned officers	874
Noncommissioned officers confining enlisted men	875
Paperwork	887
Platoons, assignment	206
Platoons, designation	205
Property responsibility	886 ; 896
Protection against surprise	268
Punishment	882
Ration return	909
Record of rifles	902
Record of size of clothing	906
Reduction and resignation of noncommissioned officers	876
Retained copies of rolls, etc.	899
Rewards and privileges	881
Right	219
School of	210 - 294
Sick report	889
Squads designation	205
Statement of clothing charged to enlisted men	904
Summary Court records	903

Target records	907
To be kept closed in on center on firing line	354
To dismiss	217
To form	215-216
Training. See " Training and instruction "	
Treatment of soldiers	872
Trials by court martial	882
Withholding privileges	884
Compass, points of	1084
Complaints to captain	1528
COMPLICATED MANEUVERS:	
Impracticable	365
To be avoided	375
Compliments from guards	1782
Compliments not paid on marches	1227
Composition of infantry and other units	1858
Comradeship, factor in training	931
Concealment and dodging, training in	1087
Condiment can, care	1309
Cone of fire or dispersion	1411
Conical wall tent	689
Connecting Files at night	584
Consolidation of organizations to provide war strength	55 (d)
Contentment and harmony in company	877
Contentment, factor in training	931
Contours	1882 ; 1866
Cooking individual	1256
Contract	249 ; 403-413
Conventional signs	1874
Coöperation between frontal and enveloping attacks	462
Coöperation of subordinates	387
Corduroying	1116
Corporal is squad leader	150
Corporal of the Guard	1666
Correction of errors, staying of execution of movements for	63-64
Correspondence book	893
COUNTER ATTACK:	
Battalion	363
General principles	525-530
Preparations	487
Countermining	1211
Countersigns and paroles	1769
Counting, indicating cadence	108
Counting off	153 ; 203
Courage	927
COVER:	

Skirmishers take advantage of, on halting	240
Use	195-199 ; 420
Training in use of	939
Covering fire, rushes made under	349
Cover trenches	1155
Crawling, advance of firing line	261
Cup, care	1310
"Cut off" habitually turned off	218 (third)
Cuts, first aid,	1490
Courtesy. See " Military courtesy "	

D

Daily sick report	889
Datum plane	1883
Decreasing intervals	247
DEFENSE:	
Action when target disappears	294
Active defense	527
Battalion on	357
Counter attack:	
Communicating and cover trenches head cover, etc., construction	505
Cover, utilization	504
Importance of counter-attack	527
Manner of making	529
Minor	530
Post of troops	528
Delaying action:	
Important considerations	531
Purposes of support and reserve	532
Thin firing line to be used	532
Value of artillery	533
Deployment:	
Advance posts and other dispersion to be avoided	520
Assignment of front to units	516
Battalions to be kept intact	518
Dead space to be covered by adjoining section or machine guns	519
Density	509 ; 510
Division of positions into sections	517
Fire alone unable to stop attack; use of bayonet	522
Night attack, steps to be taken if expected	523
Position not to be fully occupied until infantry attack begins	521
Reserve, detaching part of, to protect opposite flank	
Reserve posts	513 ; 514
Sections, divisions of positions into	517
Size of units occupying sections	518
Short range fire and bayonet in night attack	524
Strength in rear to be increased when change from defensive to offensive is contemplated	511
Supports, post and cover	512
Dummy trenches	506
Field works:	
Construction	504
Location, extent, garrison, etc.	507
Machine guns	556 ; 566
Obstacles, construction	504
Opening fire	360 ; 418
Passive	525
Position and intrenchments	503-508
Requisites of defensive position	503
Trenches, outlining trace in combat exercises	508

Defilade	1420
Deflection	1384
Deflection and elevation connection drills	1383
Deliberate intrenchments	1147
Delinquency record	895
Delivery of messages	958 ; 1530
Density of firing line	446-453 ; 532
Deploy, definition	29
Deployed line, faces to front and takes advantage of cover on halting	239
Deployed lines, alignment	239
Deployed troops, leading difficult	379
DEPLOYMENT:	
Action of brigade and regimental commanders in deployment of division	440
As skirmishes	65 ; 92 ; 170 ; 239-246
Battalion, depth of	246
Battalions furnish firing lines and support	455
Company, rules for	236
Companies and detachments taking their places	334
Dense, well directed and controlled fire gives fire superiority	446
Density of charging line	449
Density of one man per yard	447
Density of whole deployment varies with size of command	451
Division of battle line into battle districts	452
Each commander to guard his command against surprise	442
Extent of front occupied by unit depends upon security of flanks	453
For attack:	
Distance for hostile position at which deployment is made	463
Each unit to deploy on its own direction line	463
Foreground to be cleared of hostile detachments before deployment	463
Intervals between battalions	465
Moving well forward and deploying at night	464
Post of reserve	466
Reserve charged with flank protection	466
Formations of troops before and during	439
In defense. See " Deployment " under " Defense "	
In oblique direction	245
Length of firing line employed by whole force	449
Mechanism taught by extended order	55 (b)
Occupation of only sections of long lines	447
Of squads when company is deployed	239
On wrong lines, avoided by reconnaissance	403
Orders for	392
Personal reconnaissance before deployment	441
Premature to be avoided	332 ; 443
Rectification of deployments in wrong direction	444
Reserves, how employed	455
Reserves furnished by units larger than battalion	441
Rules for	236-242
Side by side of regiments, battalions and companies	454
Strength of support and reserves	449 ; 450
Supports furnished by battalion	455
To flank or rear	246
Troops deployed vary from 1 to 10 men per yard	450
Use of thin firing lines	448
When made	463
Department, military	1523

Depth, definition	30
Descriptive card of animals	898
Descriptive list	897
DESIGNATION OF:	
Companies in battalion formation	298
Squads and platoons	205
Designation of targets	1445-1147 a
Designation of winds	1391
Details and roster of guards	1585
Details to be left to subordinates	384 ; 385
Determination, factor in warfare	924
Deviation from orders	388
Devolution of work and responsibility	869
Diarrhoea	1491
Diminish intervals	172
Directions given subordinates through immediate superiors	397
DISCIPLINE:	
Definition	910
General principles	916
Importance	912
Methods of attaining good discipline	911 ; 914
Punishment	915
Sound system	913
Disciplinary exercises—drills at attention and ceremonies	55 a
Discipline and training necessary	379
Discipline, fire	291 ; 430 ; 431
Dislocations, first aid	1492
DISMISSING:	
Battalion	309
Company	217
Squad	147
Dismounted noncommissioned staff officers, posts	77 ; 78
Dismounting, before addressing dismounted superior	1558
Dismounting before saluting dismounted senior	75
DISTANCE:	
Between firing line and support	338
Between front and rear rank	153
Between units in column of subdivisions	69
Definition	31
Plates showing distances:	
Battalion	near, 300
Company	near, 207
Taken by file closers in "take distance" and "take interval"	213
DISTANCE TAKING:	
Action of guides	213
How executed	158
Distant range	275
Distance to target, determination of	276
Distribution of fire	1441-1444

Distribution of fire and target	282 ; 283 ; 427
Division of battalion into firing line and support	335
Document file	894
Dog's bite	1480
Do something	386
DOUBLE RANK:	
Company to be formed in	203
Habitual close order formation	70
Kneeling and lying down in	178
Rear rank loading and firing	179
Double sleeping bag	686
DOUBLE TIME:	
Adding preparatory command	109
Any movement executed in, unless excepted	60
Cadence	108
Command for	111
Command for precedes command of execution	60
Dropping hands by side upon halting	116
Half step, length	113
In successive movements, base unit marches in quick time	61
Position of disengaged hand	111 ; 121
To hasten movements begun in quick time	177
To the rear	118
Drainage, camping,	1248
Drainage of trenches	1167
Draw saber	671
Dress, appearance	1523
DRESSING:	
Battalion	310 ; 311
Company	218
Companies, position of captain	218 ; 302
Deployed lines	240
Drill at attention after combat exercises	55 (d)
Squad (right or left)	154
Verify both ranks	154
DRILL:	
Battalion	295-363
Company	202-294
Squad	148-202
Drills at attention and ceremonies designed to teach precision, etc.	55 (a)
Drill regulations furnished as guide, providing principles for training, etc.	53
Drill regulations, interpretation of	53
Drowning	1493
Drum major at battalion inspection	650
Dugouts, trenches	1156
Dummy trenches	1163
Duties of infantry, many and difficult	366
Duties of officers and noncommissioned officers in battle	389
Duty roster	890

Earache	1494
Ear, foreign body in	1495
Echelon definition	49
Effect of fire	1410
Effect of heat, light, etc.	1397 -1403
Effectiveness of fire	1416
Effective range	275
Efficiency dependent upon thorough and uniform training	51
Elastic formations essential to correct battle training	52
Electric shock	1496
Element, definition	32
Elevation, change of	92
Encroachment upon functions of subordinates	396
Endurance, limit of, exacted	380
Enemy—imaginary outlined and represented	56 ; 370
Entrenching at night	1099
ENVELOPING ATTACK:	
Advantages	459 ; 461
Resulting in local frontal attack	461
To be started at considerable distance from enemy	462
Envelopment of both flanks, when allowable	460
EQUIPMENT:	
Carried into action	382
Display for inspection	682
EQUIPMENT, CARE OF:	
Cloth equipment:	
General instructions	1301
Intrenching tools	1312
Shelter tent	1303
Washing	1302
Clothing:	
Grease spots	1285 ; 1289
Ink stains	1287
Leggins	1280
Paint spots	1290
Rust	1286
Stains	1284
Importance	1276
Leather equipment:	
Cleaning	1316
Cleaning materials	1315
New equipment	1318
Oiling	1317 ; 1319
Points to be remembered	1320
Mess outfit:	
Bacon can	1308
Canteen	1311
Condiment can	1309
Cup	1310
Fork	1305
Knife	1304
Meat can	1307
Spoon	1306
Rifle	1321
Shoes:	
Care	1292
Polishing	1295 ; 1299 ; 1300
Repairing	1294
Selection	1293

Wet shoes	1297
Equipment. See " Care and preservation "	
Errors staying execution of movement, for correction of	63 ; 64
ESCORTS OF:	
Funeral	640 - 645
Honor	639
The Color	637 ; 638
Establishing outpost by company	1080
Estimate of situation	950
Estimating distance	1393 - 1395
Estimating distances, training in	201
Estimators of ranges	278
Exercises in fire control and direction	1450
EXTENDED ORDER:	
Certain movements executed as in close order	241
Company	236 - 268
Company largest unit executing	55 (b)
Company largest unit to execute movements by prescribed commands	328
Exercises to be in nature of combat exercise	370
Purpose	55 (b)
Squad	170
To be executed at ease	55 (b)
Extended on first (fourth) company	321
Eye, foreign body in	1497
Eyes left, when post of reviewing officer is on left of column	626
EYES RIGHT:	
How executed	103
Battalion review	631 ; 632
Eyesight in scouting	1083
Eyes, use of	200
F	
Facings	104
Facing about to give commands, staff stands fast	74
Facing about, mounted officer turns to left	74
Facing troops when giving commands	89
Fainting, first aid	1498
"Fall in"	100 ; 153
"Fall in" executed at order	121 (fifth)
"Fall out"	100
"Fall out" executed as without arms	121 (fifth)
Falling in with hands on hips	70
Fascinés	1117 ; 1118
Faster, command for increasing rate of fire	191
Fear	926
Feet, care of	1229

Feint attacks	502
Field efficiency of organization	51
FIELD ENGINEERING:	
Bridges:	
Double lock	1114
Roadway of spar	1115
Single lock	1113
Spar	1112
Brush work	1117
Corduroying	1116
Fascines	1117 ; 1118
Gabions	1121 - 1123
Hurdles	1119
Knots:	
Bowline	1130
Clove hitch	1128
Eye splice	1135
Long splice	1134
Sheep shank	1132
Short splice	1133
Square or reef	1126
Timber hitch	1129
Two-half hitches	1127
Lashings	1136 - 1139
Revetments	1124 ; 1125
Field exercises, definition	55 (c) ; 56
FIELD FORTIFICATIONS:	
Classification	1142
Communicating trenches	1157
Concealment of trenches	1162
Cover trenches	1155
Deliberate intrenchments	1147
Drainage	1167
Dugouts	1156
Dummy trenches	1163
Example of trench system	1160
Fire trenches	1148
Hasty intrenchments	1143
Head cover	1152
Illumination of foreground	1170
Kneeling trench	1145
Latrines	1169
Length of trench	1164
Location of trenches	1161
Lookouts	1158
Loopholes and notches	1153
Lying trench	1144
Notches and loopholes	1153
Object	1140
Overhead cover	1154
Parados	1151
Preparation of foreground	1165
Revetments	1166
Siege works	1172
Sortie steps	1150
Standing trench	1146
Supporting points	1159
Telephones	1171
Traverses	1149
Trench recesses	1150
Water supply	1168
Field officers, habitually mounted	73
File definition	33
FILE CLOSER:	
Darting through column of squads	221
Execution of loadings and manual of arms	212
On the right (left) flank	211
Post in column of squads	221
Post in route marches	325

To correct mistakes	71
Files, advancing by	255
Files of orders, company	891
Fill magazine	702
Finding way in strange country	1084
Fine sight	1353 (b)
Finger system of target designation	1447 (a)
FIRE:	
By volley	189; 278
Classes of	179; 194; 278-280
Clip	192; 280
Commands for	179; 189; 194
Delay opening as long as possible	344
In deployment controlled by platoon leaders	269
Long range, when effective	416
Observation of	428; 429
Opening in attack	344; 417
Opening in defense	417
Purpose and nature	414; 415
Rate of	191; 292
To be directed against hostile infantry	345
Fire action	269
FIRE ATTACK:	
Fire superiority sought at first firing position and to be maintained until charging point is reached	472
Futility of advancing without fire superiority	473
General principles	258; 472
Intrenching	475
Retiring under fire suicidal	475
Signs that fire superiority has been gained	474
Size of rushing units	472
Supports and reserves occupying trenches vacated by firing line to improve same	476
FIRE AT WILL:	
How executed	190
Use	279
Fire control, company	287-290
Fire direction, company	285; 286
FIRE CONTROL AND DIRECTION:	
General considerations	416
Signals	431
Fire direction and control	1434-1440
Fire discipline	291; 430; 431
Fire discipline, definition	1406
Fire distribution	427; 1441-1444
Fire fight, where and when to begin, indicated by major	341
FIRE OF POSITION:	
Use of machine guns	555
When used	438
FIRE SUPERIORITY:	
Futility of advancing without	473
Purpose and nature	414
Signs that it has been gained	474
Sought at first firing position	472
To be maintained until charging point is reached	472
What it accomplishes	478
Fire trenches	1148

Fire unit, platoon	287
Firing at night	1101
Firing at stationary targets	1428
Firing by sentries at night	1104
Firing, classes of	278-280
FIRING LINE:	
Advance	258-261 ; 346
Advance as far as possible before opening fire	467
Advanced elements not to open fire on main position	471
Companies to be kept closed in on center	354
Control by signals	55 (d)
Controlled by commander when whole line has been absorbed	383
Density	446-453
Furnished by battalion	455
Placing entire battalion or regiment into	339
Premature formation to be avoided	443
Reënforcement by major	359
To advance as far as possible before opening fire	467
Firing line and support, division of battalion	335
Firings in close order	269
Firings and loadings, see " Loadings and firings "	
First aid packet	1521
First aid to sick and injured	1478
FIRST SERGEANT:	
Accompanies captain when company is deployed	207
Assists in fire control in case of depleted company	209
Duties	873
Never assigned as guide	207
Post	207
Report when company is formed	215
Fish hook, first aid	1499
Fits, first aid	1500
Fix bayonets, how executed	142
Fix bayonet order, given by major	355
Fixed forms covering all cases impossible	369
FIXED PIVOT, TURN ON:	
Company	219-221
Squad	165
When used	66
FLAG:	
Company signal carried by company musicians (now buglers)	401
Defined	1575
Of general officers, post of	73 ; 618
Respect paid to	1574 ; 1575
Signals	94 ; 400 ; 401
Signaling to artillery	437
To outline enemy	371
Flag-stealing contest	1090
FLANK:	
By the right, how executed	117
Definition	35 ; 54
Deployment as skirmishers	246
Movements executed towards either, explained toward but one flank	58
Unit to begin rush	348

FLOURISHES AT:	
Funeral	641
Review	624
Fly, disease carrier	1460
Folding tents	691
FOLLOW ME:	
In forming skirmish line	237
In rushes	259
To follow corporal	169
Footmarks, following	1088
Forced marches	1225
Fork, care	1305
FORM:	
Column of companies	315
Column of squads	316
For shelter tents	181
Formation calls	693
Formation definition	36
FORMATIONS FOR:	
Advancing improvised	257
Support	262
FORMATION OF:	
Battalion	307 ; 308
Company	215
Squad	153
Form lines	1884
Forms of speech	1526
Fortifications, attack	495 -498
FORWARD MARCH:	
From half step, halt and mark time	113
From halt	110
From oblique	163
Pieces brought to right shoulder from order, at command	121 (sixth)
Fractures	1483
Fraise	1178
Freezing, first aid	1502
Front, definition	37
Front, extent of in deployment	446 -453
FRONT OF:	
Deployed battalion	334 -337
Deployed squad	171
Frontal attacks, when they may be successful	457
FRONT INTO LINE:	
Battalion	314
Company	231
Frost-bite, first aid	1503
Full distance, definition	69
Full sight	1353 (c)
Full step, length and cadence	108
Funeral escort	640 -645

G

Gabions	1121-1123
Gallery practice	1385
Gangrene	1482
Gases, asphyxiating	1194
GENERAL COMMON SENSE PRINCIPLES OF APPLIED MINOR TACTICS:	
Art of war, definition	943
Estimating the situation	950
Maneuvers	947 ; 949
Map problems	945 ; 949
Mission, defined	950
Noncommissioned officers, responsibilities in time of war	944
Orders, tactical, preparation	952
Terrain exercises	945 ; 949
War game	946 ; 949
General officers habitually mounted	73
General plan to be furthered by subordinates	386
GENERAL RULES FOR:	
Ceremonies	614-616
Drills and formations	57-79
Parades	634 ; 635
Reviews	617-630
Gentle reverse slopes	1427
Germs	1452
Gonorrhoea	1466
Grazing fire	1423
Grease spots, how removed	1285 ; 1289
Grenades and bombs	1197-1199
Ground, use of	420 ; 421
GUARD DUTY:	
Challenging	1746
Classification of guards	1584
Commander of the guard	1603
Commanding officer	1591
Compliments from guard	1782
Corporal of the guard	1666
Countersigns and paroles	1769
Details and roster	1585
Duty of sentinels	1578
General rules concerning guard duty	1792
Guarding prisoners	1797
Guard mounting:	
Formal	1840
Informal	1847
Guard patrols	1778
Importance	1576
Musicians of the guard	1700
Officer of the day	1593
Orderlies and color sentinels	1702
Orders for sentinels	1716
Paroles and countersigns	1769
Privates of the guard	1715
Relieving old guard	1850
Respect for sentinels	1577
Reveille and retreat gun	1837
Sentinels of troops stable guard	1825
Sentinels' orders	1716
Sergeant of the guard	1642
Special orders for sentinels at post of guard	1759

Stable guards	1806
Troop stable guards	1808
Watchmen	1781
GUARD MOUNTING:	
Formal	1840
Informal	1847
Guard patrols	1778
Guarding prisoners	1797
GUIDE:	
Announcing before executing platoons right (left)	220
Definition	38
In deployment	236
In successive formations	65
Right (left)	155
What it is, unless otherwise announced	65
When given in connection with movement, follows command of execution	65
GUIDES:	
Alignment of battalion	311
Assignment to platoons	206
Battalion formed in line	308
Battalion marching in column of companies or platoons	325
Battalion parade	636
Close on first (fourth) company	320
Column of companies, first company, squads right	315
Column right (left) battalion	317
Dressing company when battalion is in line	302
Duties in battle	389
Duties in fire fight	289
Equipped with whistles	83
Execution of loading and manual of arms as file closers	212
First Sergeant never assigned as Guide	207
Guide of leading subdivision charged with step and direction in column of subdivisions	65
In successive formation guide is toward base	65
Manual of arms, execution by file closers	212
Partial changes of direction	67
Platoon guides	210
Platoon guides accompany leader when platoon is deployed	206
Positions shown in plates of company and battalion	166
Post in column of squads	211
Post of file closers in route marches	325
Rectifying column (battalion)	313
Repeating signals	83
Taking intervals and distances	213
Taking place in front rank at command about face	229
To change guides to opposite flank	211
Guide center designate left guide of center company	301
Guide right (left) command	155
H	
Half step (command)	113
HALT:	
Any movement executed from, unless otherwise prescribed	59
Firing executed at	179
From half step and mark time	113
How executed	116
Piece brought to the order	121 (seventh)
Halting, skirmishers face to the front and take advantage of cover	240

Halts on marches	1222
HAND:	
Disengaged, position at double time	111 ; 121 (Eighth)
Left, position at balance	122 (First)
On hip falling in with	70
Salute	106
Hand grenades	1198
Harmony and contentment in company	877
Hasty intrenchments	1143
Head, definition	39
Headache	1504
Head cover, trenches	1152
HEALTH, CARE OF:	
Chancroid	1466
Clap	1466
Five ways of catching disease	1453
Fly, disease carrier	1460
Germs	1452
Gonorrhoea	1466
Importance	1451
Malaria fever	1469
Mosquito, carrier of disease	1469
Syphilis	1466
Vegetables, distributor of disease	1458
Venereal disease	1466
Water, distributor of disease	1457
Yellow fever	1469
Hearing at night	1095
Hearing in scouting	1083
Heat, effect on shooting	1397
Heat exhaustion	1505
Height, men to fall in according to	203
Heliographing	864
Helmets, steel	1205
Hits, percentage	1417
Holding attack	499-502
Horizontal clock face system of target designation	1446
Horizontal equivalents	1867
Hostile Infantry, target	345
Human element in training and instruction	925
Hurdles	1119
Hygiene. See " Personal hygiene "	
I	
Illumination of foreground of trenches	1170
Imaginary enemy, definition	56 ; 370
Improvised formations for advancing	257
Incinerators, camp	1247
"Incline to the right (left)"	67
INCREASING INTERVALS:	

Company	247
Squad	172
INDIVIDUAL COOKING:	
Fire, how to make	1257
Importance	1256
Recipes	1258-1275
Individual intelligence, factor in warfare	924
INFANTRY:	
Against artillery:	
Action against artillery limbering or coming into action	600
Action against guns out of ammunition	599
Flank attack	598
Frontal attack usually futile	597
Machine guns	597
Wheel horses best targets	600
Against Cavalry:	
Cavalry charge against infantry usually futile	591
Infantry attacking dismounted cavalry	596
Measures to check charges from front and flanks	592
Meeting of cavalry charge by infantry in column	595
Rifle fire main dependence of infantry	594
Standing position, best to meet charge	593
Demands upon it by modern combat	365
Duties many and difficult	366
Good Infantry can defeat superior troops of poor quality	368
Modern war requires good infantry	366
Moving to attack, passing through deployed artillery	470
Requisites of good infantry	368
Trained to bear heaviest burdens	368
Infantry Drill Regulations	24
Influence of ground	1420
Initial combat order	394
Initiative in warfare	923
Initiative of subordinates not to be hampered	384 ; 385 ; 386
Ink stains, how removed	1286
"In place halt"	63
INSPECTION:	
Band	650 ; 653
Battalion	650 ; 654
Company	646-649
Display of equipment	682
Equipment	648
Of pieces when troop are formed and when dismissed	121 (Second)
Pistol	646
Prepare for	646 ; 649-651 ; 653
Quarters	647 ; 654
Saber	646 ; 680
Seniority at	630 ; 650
Inspection and port arms when dismissing squad	147
Inspection arms from order	145
Inspection arms, Krag rifle	698
Inspections, object of	885
INSTRUCTION:	
Captain's responsibility for	202
Commanding officers accountable for	51
In use of signals	81
Of battalion, major responsible for	295
Of recruits	97-98 (a) ; 120
Without arms	98 (a)

Instruction given subordinates through immediate superiors	397
Instruction. See " Training and instruction "	
Integrity of squads in battle	151
Intelligence, factor in warfare	924
Interest in training and instruction	922
Intermingling of units in firing line	389
Interpretations of Drill Regulations, spirit to govern	53
INTERVAL:	
Action of guides in taking	213
Battalion in deployment	454 ; 465
Between companies in deployment	354 ; 447
Between files obtained by placing hands on hip	70
Between platoon columns	252
Between regiments in deployment	454
Between skirmishers	171
Definition	40
Increasing or decreasing between skirmishers	172 ; 247
Of file closers in column of squads	221
Plates showing intervals:	
Battalion	near, 300
Company	near, 207
To take	156
Intrenching tools, care	1312
INTRENCHMENTS:	
Construction in action	475
Order of importance of operations in construction	606
Intrenchments. See " Field Fortifications "	
Introduction	50-79 ; 364-371
Inundations, trenches	1186
Invisibility best protection while advancing	468
J	
"Jab," bayonet	824 (d)
K	
Kitchen pits, camping	1246
Kitchens, camp	1245
KNEEL:	
From lying down	177
From standing	174
Position of piece	185
To aim	189
Use of position	178
Kneeling trench	1145
Knife, care of	1304
Knots	1126-1135
Knowledge of subordinates	378
Krag rifle (Infantry Drill Regulations)	696
L	
Landmarks, observing	1086
Largest unit executing extended order	55 (b) ; 328

Lashings	1136
Latitude allowed subordinates	384 ; 385
Latrines, camping	1243
Latrines in trenches	1169
LEADERSHIP:	
General consideration	372-384
Necessary to success in battle	365
LEADING:	
Company	209 ; 260
Platoon	250 ; 251 ; 259
Rush	260
Squad	150 ; 169 ; 237 ; 259 ; 289
LEATHER EQUIPMENT:	
Cleaning	1316
Cleaning materials	1315
Oiling	1317 ; 1319
Left arm, position when piece is "diagonally across the body"	122 (Second)
Left, definition	41
Left foot, stepping off with	107
Left hand, position at balance	122 (First)
LEFT SHOULDER FROM:	
Order	136
Port	136
Present	136
Right shoulder	136
Leggins, how cleaned	1280
Length of steps	107-115
Library, company	879
LIEUTENANTS:	
Assisting captain in fire control of depleted company	209
Assignment of platoons to	206
Duties, etc.,	870 ; 871
Fire control	270 ; 287-289
Intermingling of units in firing line	389
Leading in charges	356
Posts of	71
Rushes by platoons	259 ; 293
Suspending fire when target disappears	294
Taking post when company is formed	215
Training	369
LIEUTENANT COLONEL:	
Salute in ceremonies	615
Light, effect on shooting	1399
Lightning, struck by	1507
Line, definition	42
Line of platoons, companies, etc., definition	68
Line of skirmishers	169-172 ; 236-247
Lines of information	398-402
Liquid fire	1196
Listening posts, trenches	1191
Litters, improvised	1522
Loaded pieces not to be carried	121 (First)

Loading pieces before deployment	269
Loading, with Krag rifle	701
LOADINGS AND FIRINGS:	
Aiming point:	
Announced before or after range	181
Once designated, not changed unless ordered	182
By battalion	306
Cease firing	194
Clip fire	192
Color guard does not execute	666
Commands	179 ; 185 – 194
Continuing the fire (command)	189
Execution by file closers	212
Fire at will	190
Fire faster (slower)	191
Firing:	
Executed in line and skirmish line only	179
Instruction in, preceded by command to load	179
Rear rank kneeling or lying down	179
Firings executed at halt	179
Instruction in firing to be preceded by command for loading	179
Load:	
Command	185
Position of, when taken	183
Rear rank, kneeling or lying down	179
Target:	
Announced before or after range	181
Once designated, not changed unless ordered	182
Loadings executed in line and skirmish line only	179
Long whistle blast	193
Pieces once loaded, so kept until command to unload	180
Position of load, when taken	183
Range and command announcing	188
Sight setting, aiming point announced before or after	181
Simulate load (command)	186
Single loader, use of piece as	186
Sling, use when deployed	184
Suspend firing	193 ; 194
Local successes necessary to general success	367
Location of trenches	1426
Lock pieces	700
Long blast of whistle	193 ; 271
Long range	275
Long-range fire	1414
Long-range fire, when effective	416
Lookouts in trenches	1158
Loopholes and notches	1153
Loose pieces	161
Lost, what to do	1085
Lying down	175 ; 185 ; 189
Lying down position, use	178
Lying trench	1144

M

MACHINE GUNS:	
Concealment	564
Covering dead spaces on defensive	519
Covering withdrawal	546 ; 557
Effectiveness against skirmish line	559

Fire of position	438 ; 555
In attack	555
In defense	555
In infantry attack against artillery	597
In meeting engagements	553
Lessons of European war	561 -568
Location on defense	566
Methods of transportation	563
Not to form part of firing line of attack	558
Silencing of machine guns by infantry	560
To be used for short periods	552
Use in villages	565
Weapons of emergency	551
With advance guard	553
With rear guard	554
With reserve	557
MACHINE GUN COMPANY:	
Post in formations	71 ; 72
Post when attached to battalion	299
MAJOR:	
Apportions target	340
Controls support	263
Duties and responsibilities as battalion commander	295
Duty regarding protection of flanks	412 ; 413
Gives order to charge	356
Gives order to fix bayonets	355
Indicates where or when fire fight begins	341
Locates trenches and obstacles	358
Order making disposition of battalion for combat	329
Orders bayonets fixed on defense	361
Post during attack	352
Post in route march	325
Reënforces firing line	359
Responsibility regarding ammunition	570
See " Battalion commander "	
Malarial fever	1469
Maneuvers	947 ; 949
Maneuvers effective method of conducting	371
MANUAL OF:	
Arms:	
"By the numbers"	122 (Fifth)
Cadence	122 (Fourth)
Carrying rifle in any position	122 (Sixth)
Executed by color guard	666
General principles and the manual	120 -147
Regular positions assume without regard to previous ones	122 (Sixth)
"Without the numbers"	122 (Fifth)
Bugle	692 -695
Color	658 -670
Saber	671 -680
Tent pitching	681 -691
The color	670
MANUAL OF BAYONET:	
Bayonet combat	760
Combined movements	802
Fencing at will	807
Fencing exercises	772
General remarks	711
Guard	725
Hints for instructors	823
Instruction with rifle	734
Instruction without bayonet	755
Instruction without rifle	723
Jab	824 (d)
Lessons of European war	824
Nomenclature	721
Short point	824 (d)

Map, definition	1859
Map distances	1867
Map problems	945 ; 949
Map problems, instruction in	954
MAP READING:	
Contours	1866
Conventional signs	1874
Definition of map	1859
Determination of positions of points on map	1871
Horizontal equivalents	1867
Map distances	1867
Meaning of map reading	1860
Meridians	1870
North star	1873
Orientation	1872
Problems in scales	1864
Scale of map distances	1867 (a)
Scales	1861-1863
Scaling distances from map	1865
Slopes	1868
True meridian	1873
Visibility problem	1875
Map sketching. See " Military map sketching "	
MARCH:	
At funeral	641
Played as honor	624
MARCHES:	
A successful march	1215
At night	1102
Care of feet and fitting of shoes	1229
Compliments not paid on marches	1227
Conduct on march	1220
Crossing bridges and fords	1223
Elongation of column	1224
Fitting shoes and care of feet	1229
Forced marches	1225
Halts	1222
Hardening new troops	1213
Long march not to be made with new troops	1214
Marching capacity	1221
Marching, principal occupation of troops in campaign	1212
Night marches	1226
No compliments paid on	1564
Physical training	1213
Preparation for march	1216-1218
Protection on march	1228
Rate of march	1220
Starting on march	1219
Stragglings	1224
Marching, any movement executed when, unless otherwise prescribed	59
Marching to rear, skirmishes, not assembled	173
Marchings and steps	107-119
MARK TIME:	
Executed from half step, halt and mark time	113
How executed	112
While obliquing	163
Masks, protection against gases	1206
Mass formation, battalion	320
Meat can, care	1307
Mechanism of deployment taught by extended order	55 (b)

Meeting engagements:	
Action of advance guard prior to receipt of order	543
Action of column	542
Action of the leading troops	541
Advantage accrues to side deploying the faster	539
Afford ideal opportunity to certain commanders	537
Boldness and determination of commander	536
Characteristics of	534
First troops deploying have advantage	539
Function of advance guard	542
General action	535
Machine guns, use	552
Main body not to be put into action piece meal	544
Meagerness of information	536
Mission determines method of attack	538
Post of commander	542
Memorandum receipts, company	900
Meridians	1870
Mess, company	878
Mess outfit care	1304
Messages, delivery	1530
Messages, instruction in delivering	958
Metal fouling, removing from bore	1327
Method in training and instruction	918
Military appearance and deportment	1523
MILITARY COURTESY:	
Colors and standards	1575
Headdress not raised in saluting	1569
National anthem	1572
National anthems of other nations	1573
Nature and origin of salutes	1533 ; 1534
Prisoners do not salute	1567
Soldier walking with officer	1566
Unmilitary salutes	1568
Usual mistakes in saluting	1571
When and how to salute:	
At meals	1543
At work	1547
Bringing command to present before commander	
salutes	1563
Commanders of detachments or other commands	1561
Dismounting before addressing, superior not	
mounted	1558
General rule	1539
How to salute in uniform	1551
Indoors	1545
In public places and conveyances	1560
Man addressed in formation	1559
No compliments paid at drill, on march, etc.	1564
No saluting at double time, trot or gallop	1565
Officer approaching number of soldiers in open	1546
Officer entering room occupied by soldiers	1542
Officer passing in rear of troops	1562
Passing officer on staircase	1549
Riding in wagon	1548
Rifle salute	1552
Saber salute	1553
Saluting distance	1541
Saluting in civilian dress	1555
Saluting in military manner	1556
Sentinels on post	1554
Several officers together	1557
Soldier addressing or being addressed by officer	1550
When making and receiving reports	1540
When seated	1544
Whom to salute:	

Army officers	1535
Foreign, naval and military attaches	1538
Navy, Marine Corps, Volunteer and National	
Guard officers	1536
Reserve Corps officers	1537
MILITARY MAP SKETCHING:	
Combined sketching	1892
Contours	1882
Datum plane	1883
Different methods of sketching	1878
Form lines	1884
Kinds of military sketches	1878
Location of points by intersection	1879
Location of points by resection	1880
Location of points by traversing	1881
Outpost sketching	1890
Points for beginners to remember	1893
Position sketching	1889
Road sketching	1891
Scales	1885 ; 1888
Military organization	1858
Military pits	1184
Military training object of	50
Mine warfare. See, " Trench and mine warfare "	
MINOR WARFARE:	
Camp or bivouac protection	612
Dividing marching column into two or more detachments	611
Formations in close country	610
Formation in open country	609
Irregular operations	607
March and bivouac formations to admit of rapid action in any direction	608
Night operations frequently advisable	613
Regular operations	606
Selection of site for camp or bivouac	612
What it embraces	606
Mirage	1400
Mission, defined	950
Mistakes, staying execution of movement for correction of	63 ; 64
Modern combat, demands upon infantry	365
Modern war requires good infantry	366
Moisture, effect on shooting	1398
Morning report	888
Morse code	866
Mosquito, carrier of disease	1469
Mounted enlisted men formed into a detachment for ceremonies	76
Mounted officer in making about face, turns to left	74
MOUNTED SCOUTS:	
Battalion staff officers, training in patrolling and reconnaissance	579
Dismounted patrolling	578
How used	576
Post when attached to battalion	299
To be trained in patrolling and reconnaissance	576
Use for reconnoitering	577 ; 578
Mouse and cat contest	1089

Movement, any executed in double time unless excepted	60
MOVEMENTS:	
Begun in quick time, hastened by command, "Double time"	62
Executed toward either flank, explained toward but one flank	58
General rules	57 ; 63
May be executed from halt or when marching	59
MOVING PIVOT, TURNING ON:	
Company	222 ; 227
Squad	164
When used	66
Moving targets, firing at	1432
MUSICIANS: (now buglers)	
Duties during firing	272
Equipped with whistles and repeating signals	83
Join their companies at battalion inspection	650
Post	207
To carry signal flags	94 ; 401
To repeat signal to fix bayonet and charge	355 ; 356
Musicians (now buglers) of the Guard	1700
Muster	655 -657

N

NATIONAL AIR:	
At funeral	641
Playing as honor at review	624
National Anthem	1572
National color does not salute	660
Next to last motion in resuming order from any position	122 (Third)
Night firing	1433
Night marches	1226
NIGHT OPERATIONS:	
Advance and rear guards	584
Approaching charging point under cover of darkness	496
Attack, time of making	588
Bayonet use	583 ; 586 ; 589
Challenging	1103
Connections	1107
Defense, measures taken to resist night attacks	590
Deployment at night	464
Equipment	1100
Finding bearings	1096
Fire action to be avoided	583
Fire not effective beyond 50 yards	590
Formations	581 ; 586 ; 589
Hearing	1095
Importance	1091
Individual training	1093
Marches	1102
Marking route outguards to supports	1105
Moving in dark	1097
Night advance followed by attack by day	585
Night entrenching	1099
Night fencing	1098
Night firing	1101
Night matches	584
Outposts	1103
Practice in offensive and defensive operations	581
Preparation	1108
Purposes	580
Readiness for action	1106
Reconnaissance	587

Secrecy	583
Sentries firing	1104
Surprise	587
Trained troops necessary	586
Training of company	1092
Unfriendly guides	583
Vision	1094
White rag, tying around muzzle of rifle	590
Nomenclature of rifle	1342
Noncommissioned officer commanding platoon or company carrying of piece and taking of post	79
Noncommissioned officers, post of	71
Noncommissioned officers to be obeyed and respected	1525
Noncommissioned officers, company, duties	874
Noncommissioned officers confining men	875
Noncommissioned officers; instructions in map problems	954
Noncommissioned officers; reduction and resignation	876
Noncommissioned officers; responsibilities in time of war	944
"Normal" forms covering all cases impossible	369
Normal sight	1353 (a)
North star	1873
Nose, foreign body in	1507
Notches and loopholes	1153
Number of troops to be deployed in beginning	445
"Numbers, by the"	122 (fifth)

O

Obedience	1524
Object of military training	150
OBJECTIVE—	
Announced before or after range	181
Once designated not changed unless ordered	182
Oblique deployment as skirmishers	245
Oblique march	162-163
Observation	200-201
Observation of target and fire	428-429
OBSTACLES:	
Abatis	1176
Against cavalry	1180
Automatic alarms	1192
Barricades	1185
Cheveaux de frise	1179 ; 1189
Fraise	1178
Guarding obstacles	1190
In front of outguards	1187
Inundations	1186
Kinds	1176
Lessons from European War	1188
Listening posts	1191
Location	1175
Military pits	1184
Necessity for	1174
Object	1173
Palisade	1177

Search lights	1193
Trous de loup	1184
Wire entanglements	1181 ; 1182 ; 1188
Wire fence	1183
Obstacles located by Major	358
Occupation of ground	1426
Offensive necessary for decisive results	367
Office, how to enter	1527
Officer of the Day	1593
OFFICERS:	
Posts of	71
To be true leaders	377
To comply with spirit of orders	377
Oil, use on rifle	1330 ; 1339
ON RIGHT (LEFT) INTO LINE:	
Battalion	313
Company	230
Open packs	648
Open ranks	646
Open sight	1352 (a)
Opening fire on defense	360
ORDER:	
Assumed in resuming attention from rest or at ease	121 (fifth)
Piece brought to, upon halting	121 (seventh)
Piece striking ground gently	122 (third)
Position in next to last motion	122 (third)
Position of piece at	123
Order and cohesion in combat	376
Order, close, definition	43
Order, extended, definition	44
ORDER FROM:	
Inspection	146
Left shoulder	136
Port	128
Present	128
Right shoulder	130
Trail	140
ORDERLIES:	
Carrying signal flags	400
Do not change position when commander faces about to give command	74
Posts of	73 ; 78
ORDERS:	
Battle	392
Brigade and division, usually written	392
Compliance with spirit of	377
Composition of combat order	395
Definition	85
Deployment	392
Deviation from	388
Encroaching upon functions of subordinates, prohibited	396
Given subordinates through immediate superiors	397
Reconnaissance to precede issuing of initial combat orders	394
Regiment, usually verbal	393
Repetition of	83
To be definite	396
Use in battalion combat	328

Verbal	393
When used	80 ; 85
Orders, files of, company	891
Orders for sentinels	1716
Orders, tactical preparation	952
Organization, military	1858
Orientation	1872
Outlined enemy	56 ; 273 ; 370 ; 371
Outpost, establishing by company	1080
Outpost sketching	1890
Outposts at night	1103
Overhead cover, trenches	1154

P

Pace, definition	45
PACK:	
Close	648
Display of contents for inspection	682
Laid aside in action	382
Open	648
Packs, unslinging, old equipment	706
Paint spots, how removed	1290
Palisade	1177
Paperwork, company	887
PARADE REST:	
With arms	137
Without arms	101
PARADES:	
Battalion	636
General rules	634 ; 635
Post of color guard	663 ; 664
Parados	1151
Paroles and countersigns	1769
Partial changes of direction, commander of	67
Patrolling. See, " Scouting and patrolling "	
Payment of soldier	1529
Peep sight	1352 (b)
Percentage of hits	1417
Periscopes	1207
Personal hygiene	1470
PERSONAL RECONNAISSANCE:	
Deployment	441
Formation of plan	394
PHYSICAL TRAINING:	
Commands	826
Double timing	846
Methods	825
Rifle exercises	847
Setting up exercises	826 ; 837
Starting positions	834

Walking and marching	845
PIECE:	
Carrying in any position	122 (Sixth)
"Diagonally across the body"	122 (Second)
Loading before deployment	269
Not to be carried loaded	121 (First)
Once loaded, so kept until command to unload	180
Rules governing carrying	121
To strike ground gently in coming to order	122 (Third)
Use as single loader	186
Pitching tents	684
PLAN:	
Of battle preceded by personal reconnaissance	394
Of combat, adherence to original	373
PLATES:	
Battalion	near, 300
Company	near, 207
Equipment	near, 646
PLATOON COLUMN:	
Assembly from	254
Deployment	253
How executed	250
Use in advancing	249-252
PLATOON DRILL:	
Assembling from deployment	248
Column right (left) (company being in column of platoon)	223
Extended order	242
On right into line (being in column of platoons)	230
Platoons column right (left) (company being in column of squad)	225
Platoon light (left)	220
Platoons right (left) by squads (being in line)	227
Platoons right (left) front into line	232
Squads right about (being in line of platoons)	228
Squads right (left), platoons column right (left) (being in line)	227
PLATOON GUIDES:	
Close order drill	210
Duties in fire fight	289
PLATOON LEADER:	
Allotment of target to	282
Control the fire in deployment	270
Duties on fire fight	288; 289
Equipped with whistles	83
Of flank platoons when company acts alone	268
Positions in verifying alignments	218
Repeating commands	214
Platoon, the fire unit of	287
PLATOONS:	
Advance into an engagement	249
Assignment	206
Designation	205
Division of company into	204
Point of aim	1357
Point of rest, definition	46
Point on which base squad marches in deployment	238
Points of compass	1084
Poison, first aid	1508
PORT ARMS FROM:	
Inspection	146

Left shoulder	136
Order	125
Present	126
Right shoulder	132
Position and aiming drills	1365
POSITION FIRE:	
Advance by rushes	293
When used	438
POSITION OF:	
Captain in dressing company	302
Load, when taken	183
Piece at order	123
Piece "diagonally across the body"	122 (Second)
The soldier	99
Position sketching	1889
POST OF:	
Band	71 ; 299
Commander in fight	383
Color	637 ; 638 ; 650 ; 664 ;
File closers in column of squads	885
Major during attack	352
Major in route order	325
Mounted enlisted men	73 ; 76 ; 78
Noncommissioned officer in command of troops	79
Noncommissioned staff officers	77 ; 78
Officers, noncommissioned officers and special units (band and machine gun company) shown in plates	71 ; 72
Reviewing officer	617
Special units	71 ; 72 ; 299
Staff officers	73
Powder fouling, removing from bore	1327
Practical instruction, purpose	369
Precision taught by drill at attention	55 (a)
Preliminary drills	1355
PREPARATORY COMMAND:	
Arrangements of elements	57
To revoke	64
What it indicates	87
PRESENT ARMS FROM:	
Left shoulder	136
Order	124
Port	127
Right shoulder	133
Present saber	673
Principles of combat, extent to which treated in Part I	54
Prisoners do not salute	1567
Privates of the Guard	1715
Privileges, awarding	881
Privileges, withholding	884
Program of training	919
Progression in training and instruction	917
Property, responsibility, company	886 ; 896
PROTECTION:	
By reconnaissance	410 ; 412
When battalion is acting alone	330
When company is acting alone	268
Protection against surprise when company is acting alone	268

PUNISHMENT:	
Awarding	915
Company	882 ; 883
PURSUIT:	
Additional force for	483
General principles	490 ; 494
Pursuing fire	486
Troops used for	487

Q

Quartermaster sergeant (now supply sergeant) assignment at drill	207
Quibbling, avoiding, in interpreting drill regulations	53
QUICK TIME:	
Cadence	108
From double time	111
Movements habitually executed in	109

R

RANGE:	
Classification	275-277
Command announcing	188
Determining of	276 ; 277 ; 426
Finders	277
Importance of correct sight setting	425
In attack	344 ; 426
In defense	426
Signal for announcing	92
Range, how determined	1429
Range practice	1386
Ranging volleys	278
Rank, definition	47
Rapid fire exercises	1372
RATE OF:	
Fire	191 ; 292 ; 415 ;
Quick and double time	1409
Ration return	909
Ready	189
Reality in training	922
Rear guard, use of machines guns as part of	554
Rear marching, skirmishers, not assembled	173
Rear rank not loading nor firing kneeling or lying down	179
Rear sight, description	1343
Rear, to the, how to execute	118
RECONNAISSANCE:	
Battalion acting alone	330
Combat	403-413
Company acting alone	268
Company advancing into an engagement	249
Each commander to guard against surprise	442
Meeting engagement	534 ; 538
Minor warfare	608
Night operations	587
Personal before deployment	441
To precede formation of plan	394
Record of rifles	902

Record of size of clothing	906
Records, company	887-909
Recruits, instruction	97-98 ; 120 ; 152-156
Rectifying column, (battalion)	312
Red bugs	1488
Reduction and resignation of noncommissioned officers	876
Reënforcement of firing line by major	359
Reënforcements, size	353
Reënforcing firing line	263-366 ; 354
REGIMENT:	
Interval in deployment	454
Lines of communication established by Muster	400 655-657
REGIMENTAL COLOR:	
Salutes by	660
Saluting reviewing officer	622
REGIMENTAL COMMANDER:	
Action in deployment of division	440
Decide equipment carried into action	382
Rejoining command after completion of task	390
REPETITION OF:	
Command for guides, by captains at battalion drill	301
Commands by captains at battalion drill	300
Orders, commands and signals	83 ; 88
Report, first sergeant's when company is formed	215
Reports, saluting when making or receiving	75
Represented enemy, definition	56
Requisites of good scout	1031
RESERVE:	
Captured position strengthened by reserves	492
Commander of troops in action habitually with reserve	383
Covering withdrawal of attacking troops	489
Deployment to enable withdrawal of faulty firing line	444
Enveloping attack	461 ; 462
Fire of position in decisive action	438
Furnished by units larger than battalion	455
Gives impetus to charge	481
How used	455
In attack charged with flank protection	466
In withdrawal from action	547
Machine guns as part of	557
Occupying trenches vacated by firing line to improve same	476
Of firing line, strength	449 ; 450
Part played by, in pursuit	491
Post and strength in holding attack	500
Post of, in attack	466
Post of, in defense	513
Post of, in delaying action	532
Reduction of reserve in case of protected flanks	452
Regimental:	
Ammunition sent from	574
Use of, in case of victory	383
Respect, factor in training	929
Respect for sentinels	1577
Respect to noncommissioned officers	1525

Responsibility, devolution of	869
Responsibility for proper training	921
Rest, executed as without arms	121 (Fifth)
Rests, the	100 ; 101 ; 121
"1. Resume 2. March"	63
Retained copies of rolls, etc., company	899
Retiring under fire	475
Return saber	679
Reveille and retreat gun	1837
Reverse slopes	1427
Revetments	1124 ; 1125 ; 1166
REVIEWS:	
Band	623 ; 624
Battalion	631 - 633
Battalions, after passing reviewing officer	628
Brigades, or larger commands	628 ; 629
Cadence at which troops pass in review	627
Commander faces command	614
Flank to pass 12 paces from reviewing officer	617
Flourishes	624
Formation of companies, battalions and regiments	616
General rules	617 - 630
March, played as honor	624
National air, playing as honor	624
Order in which troops are arranged	614
Passing around line	618 ; 631
Points where column changes direction	617
Post of reviewing officer on left of column	626
Post of reviewing officer and others	617
Reviewing officer returns only salute of commanding officer	618
Reviewing officer, post	617
Reviewing officer junior to commanding officer	630
Riding around troops	618
Ruffles	524
Salute by regimental color	622
Salute returned by reviewing officer	618
Salute by lieutenant colonel	615
Saluting by staff	615 ; 619
Saluting the color	618
Standing "at ease" etc., in case of brigade or larger command	629
Subordinates face to front	614
To the color	624
Turning out of column by commanding officer of troops	620 ; 621
Revoking preparatory command	64
Rewards and privileges, company	881
Ricochet shots	1425
RIFLE, care and description:	
Army regulations	1341
Bore	1322 - 1324 ; 1328
Description	1342
Importance	1321
Kinds of fouling	1325
Oil, how to apply	1339
Oiling barrel	1330
Rear-sight leaf	1343
Removing metal fouling	1327
Removing powder fouling. See " Piece "	1326
Rifle exercises	847

RIFLE SALUTE AT:	
Order or trail	141
Right shoulder	140
RIFLE TRAINING AND INSTRUCTION:	
Adjustment of fire	1428
Aiming exercise	1368
Aiming point	1357
Aiming and sighting	1350
Appearance of objects	1396
Auxiliary aiming points	1431
Ballistic qualities of rifle	1410
Battle sight	1352 (c)
Beaten zone	1413
Center of impact	1412
Clock system of target designation	1446 ; 1447
Clock system of wind designation	1391
Cold, effect on shooting	1397
Collective instruction	1404
Combat exercises	1408
Combat practice	1404
Combined sights	1430
Communication in fire control and direction	1447 (b)
Cone of fire or dispersion	1411
Defilade	1420
Deflection	1384
Deflection and elevation correction drills	1383
Designation of targets	1445-1447 (a)
Designation of winds	1391
Distribution of fire	1441-1444
Effect of fire	1410
Effect of heat, light, etc.	1397 ; 1403
Effectiveness of fire	1416
Estimating distance	1393-1395
Exercises in fire control and direction	1450
Finger system of target designation	1447 (a)
Fine sight	1353 (b)
Fire direction and control	1434-1440
Fire discipline, definition	1406
Fire distribution	1441-1444
Firing at stationary targets	1428
Full sight	1353 (c)
Gallery practice	1385
Gentle reverse slopes	1427
Grazing fire	1423
Heat, effect on shooting	1397
Hits, percentage	1417
Horizontal clock face system of target designation	1446
Individual instruction	1349
Influence of ground	1420
Light, effect on shooting	1399
Location of trenches	1426
Long range fire	1414
Mirage	1400
Moisture, effect on shooting	1398
Moving targets, firing at	1432
Night firing	1433
Normal sight	1353 (a)
Object of system	1344
Occupation of ground	1426
Open sight	1352 (a)
Peep sight	1352 (b)
Percentage of hits	1417
Point of aim	1357
Position and aiming drills	1365
Preliminary drills	1355
Program of instruction	1348
Range, how determined	1429
Range practice	1386
Rapid fire exercise	1372
Rate of fire	1419
Reverse slopes	1427
Ricochet shots	1425
Sighting and aiming	1350
Shot group	1412

Sighting drills	1356; 1383
Sights, kinds of	1352
Sling, use	1387
Slopes gentle reverse	1427
Stationary targets firing at	1428
Target designation	1445-1447 (a)
Targets, number hit	1418
Technical principles of firing	1409
Trajectory	1349
Trial shots, determination of range	1395
Triangle of sighting	1359
Trigger squeeze exercise	1370
Vertical clock face system of target designation	1447
Volleys, determination of range	1395
Windage	1384
Zero of rifle	1392
Zone of effective fire	1415
Right (left) about, squad	167
RIGHT (LEFT) BY:	
File	235
Squads	226
Two's	234; 235
Right, definition	48
Right (left, center) dress	154; 310; 311
Right face	104
RIGHT (LEFT) FRONT INTO LINE FROM:	
Close column	322
Column of platoons or squads (company)	231
Column of squads or companies	314
Column of two's	235
Right half face	104
RIGHT (LEFT) HALF TURN:	
Command	67
Squad	164
Right (left) oblique	163
RIGHT SHOULDER FROM:	
Inspection	146
Left shoulder	136
Order	129
Port	131
Present	134
Right shoulder, pieces brought to, from order at command "March"	121 (Sixth)
Right (left) step, how executed	114
RIGHT (LEFT) TURN:	
Company	222
Squad	164
Rise, how executed	176
Road sketching	1891
Route march, post of major and file closers	325
Route step	233
RUFFLES AT:	
Funeral	641
Review	624
RULES FOR:	
Carrying piece	121 (First)
Ceremonies	614-616
Close order (battalion)	300-306
Close order, company	210-214

Deployment	236-242
Drills and formations	57-79
Execution of manual	122
Parades	634 ; 635
Reviews	617-630
Salutes	75
Steps and marchings	107-119
RUSHES:	
Advances made under covering fire	349
Begun by flank company	348
Command for	259
Company as whole led by captain	260
Prearranged methods prohibited	351
Size of rushing units	346 ; 347
Subsequent advancing	350
Use of position fire	293
When impossible for company to advance as a whole	258
Rust, how removed	1286
S	
Saber, manual of	671-680
Safety lock	121 ; 185
SALUTES:	
Hand	106
Returned by reviewing officer	618
Rifle	141
Saber	75 ; 673
With color	660
See "Honors and salutes" also " Military Courtesy "	
SALUTING:	
By lieutenant colonel in ceremonies	615
By staffs in ceremonies	619
Mounted junior to dismount before saluting	
dismounted senior	75
On marches	1227
Regimental color	622
The color in reviews	618
When making or receiving reports	75
Saluting volleys fired in close order	269
Sapping, advancing to charging point	498
Scalds, first aid	1509
Scale of map distances	1867 (a)
Scales	1861-1869
Scales of maps	1885-1888
Scaling distances from map	1865
SCHOOL OF THE:	
Battalion	295-363
Company	202-294
Soldier	97-147
Squad	148-201
SCOUTING AND PATROLLING:	
Eyesight and hearing	1083
Cat and mouse contest	1089
Concealment and dodging	1087
Finding way in strange country	1084
Flag stealing contest	1090
Footmarks, following	1088
Landmarks, observing	1086
Lost, what to do	1085
Mouse and cat contest	1089
Points of compass	1084
Requisites of good scouts	1031

"Tracking"	1088
Scouts; See, " Mounted Scouts "	
Scratches, first aid	1510
Search lights, trench warfare	1193
Seeing at night	1094
Semaphore signaling	863
Semi-blindness	1512
Sentinel's orders	1716
Sentinels, respect for	1517
Sentries firing at night	1104
Separated officers and others placing themselves under order of nearest higher commander	390 ; 391
Sergeant of the guard	1642
Service calls	695
SERVICE OF INFORMATION:	
Bridges, facts to be obtained about	1000
Bridges, reconnoitering of	992
Buildings, reconnoitering of	996
Camp noises	985
Camps, abandoned	986
Canals, facts to be obtained about	1003
Cross roads, how reconnoitered	989
Defiles, facts to be obtained about	1006
Defiles, reconnoitering of	991
Demolitions	1011
Enclosures, reconnoitering of	994
Facts to be obtained about various objects	998
Fords, reconnoitering of	992
Heights, facts to be obtained about	1010
Heights, reconnoitering of	990
Houses, reconnoitering of	996
Indications to be noticed by patrols	983
Marches, facts to be obtained about	1007
Patrolling:	
Facts to be obtained about various objects by patrols	998
Civilians	970
Flames and smoke	987
Messages	979 ; 980
Model reports	1016
Night work	975
Patrol fighting	977
Principles of patrolling	967
Patrols:	
Acting upon meeting hostile patrols	971
By whom furnished	962
Coördination before departure	966
Definition	959
Formation	968
Guarding against being cut off	974
Halts	970
Inspection before departure	961
Leaders	961
Orders and instructions	963
Preparation for starting	965
Prisoners to be captured	984
Problems	1017 - 1019
Rate of march	969
Report on return	1015
Returning by different route	973
Scattered patrols	972
Signals	978
Size	960
Ponds, facts to be obtained about	1007

Positions, reconnoitering of	995
Railroads:	
Demolitions	1013
Facts to be obtained about	999
Reconnaissance of positions	989
Rivers, facts to be obtained about	1001
Roads, facts to be obtained about	998
Signs to be noticed by patrols	983
Springs, facts to be obtained about	1008
Suggestions for gaining information about the enemy	983
Suggestions for reconnaissance of positions	989
Telegraph line, demolition	1012
Telegraphs, facts to be obtained about	1004
Valleys, facts to be obtained about	1009
Villages, facts to be obtained about	1005
Villages, reconnoitering of	997
Vision limits of	988
Wagon roads, demolition	1014
Woods, facts to be obtained about	1002
Woods, reconnoitering of	993
SERVICE OF SECURITY:	
Advance guard, general principles	1021 -1024
Advance guard order	1025 -1026
Advance guard problems	1033 -1046
General principles	1020
Outposts:	
Advance cavalry	1056
Cavalry outpost	1071
Changes for the night	1075
Communication between subdivision	1074
Composition	1053
Concealment	1068
Cossack post	1061
Definition and duties	1051 -1052
Detached posts	1069
Distances between subdivisions	1055
Entrenchments	1067
Establishing the outpost	1073
Examining posts	1070
Flags of truce	1066
Formation	1054
Intercommunication	1074
Obstacles	1067
Outguards	1058
Outpost order	1073
Patrols	1064 -1065
Pickets	1059
Problems	1077 ; 1078 ; 1079
Relieving outpost	1076
Reserves	1063
Sentinels	1062
Sentry squad	1060
Subdivisions	1054
Supports	1057
Problems, advance guards	1033 -1046
Rear guard, general principles	1047 -1050
Setting-up exercises	826 ; 837
SHELTER TENT:	
Care of	1303
Pitching:	
New model	682
Old model	707 -710
Striking	687
Shock, first aid	1511
SHOES:	
Care	1292
On marches	1229
Polishing	1295 ; 1299 ; 1300
Repair	1294
Selection	1293

"Short point"	824 (d)
Shot group	1412
Shots grazing enemy have approximate value of hits	291
Sick report	889
Side step	114
Siege operations	496
Siege works	1172
Sight rear, description	1343
SIGHT SETTING:	
Command	188
Importance	425
Sighting and aiming	1350
Sighting drills	1356 ; 1383
Sights, kinds of	1352
Signal Corps, establishment of lines of communication	399
SIGNAL FLAGS:	
Carried by musician (now bugler)	94 ; 401
Carried by orderlies	400
Description	94
Use	95
SIGNALING:	
"Chop chop" signal	863
General service code	861
Heliograph, flash lantern, searchlight	864
Morse code	866
Semaphore code	863
Sound signals	865
Wigwag	862
SIGNALS:	
Arm	92
Attention fixed at first motion	82
Bugle used on and off the battlefield	90
Captain of supporting company to look out for major's signals	263
Cease firing	90
Change elevation	92
Commence firing	90
Communication between firing line and reserve	96
Flag	94 ; 96
For "Platoon" and "Squad," use of	93
Instruction in use of	81
Limitation of	84
Long blast of whistle:	
Signifies suspension of firing	193
To be avoided as signal for cease firing in rushes	234
Movement commences when signal is understood	82
Range, to announce	92
Repetition of	83
Special prearranged	84
Training in use of, to control firing line	55 (d)
Use during firing	271
Use on firing line	431
Use of saber, rifle, or headdress in making	81
When used	80
Whistle	91
Simple maneuvers best	375
Simple movements essential to correct battle training	52
Simulate load, how executed	186
Simultaneous movements by companies or platoons in	

battalion drill	305
Single loader, use of rifle as	186
Single rank	98 (a); 616
Sitting position used instead of kneeling one	178
Size of clothing, record	906
SKIRMISHERS:	
Deployment:	
Company	243
General rules	236-244
Squad	170
To rear	246
Face to front and take advantage of cover on halting	240
Interval between	170; 172; 247; 255;
Not assembled, marching to rear	473
To form from platoon or squad column	253
Skulking of troops carrying back wounded	381
Sky lines to be avoided	421
Sleeping bag	685; 686
SLING, GUN:	
Adjustment and use	1387
Included in grip of piece at balance	122 (First)
Use when deployed	184
Sling packs, old equipment	706
Slopes, gentle reverse	1427
Slopes on maps	1868
Slower, fire	191
Small arms firing. See " Rifle training and instruction "	
Smartness taught by drills at attention, etc.	55 (a)
Snake's bites	1480
Sniperscope	1208
Snow blindness	1512
Sore throat	1513
Sortie steps	1150
Sound signals	865
Special units; posts of	71; 72
Spider bites	1514
Spirit of order to be complied with by officers	377
Spirit to govern in interpreting drill regulations	53
Splicing	1133-1135
Splints	1484
Spoon, care	1306
Sprains, first aid	1516
SQUAD:	
Base	236; 239
Composition	149
Dressing	154
Front when deployed	171
Integrity in battle	151
Movements executed as prescribed in school of the	

soldier	152
Right	165
Right (left) about	167
To dismiss	147
To form	153
SQUAD COLUMN:	
Deployment	253
How executed	251
To assemble from	254
Use in advancing	249 ; 252
Squad drill, object	149
SQUAD LEADER:	
Action at preparatory command for forming skirmish line	237
Corporal is	150
Duties in fire fight	289
Post	150
SQUADS:	
Deployment when company is deployed	239
Designation	205
Division of company into	203
Grouping soldiers into	148
Preservation of integrity in battle	151
Right (left) about	228
Right (left) column right (left)	226
Right (left) front into line	235
Stable guards	1806
Stack arms	160 ; 161
STAFF:	
Does not change position when commander faces about to give command	74
Draws and returns saber with chief	73
Habitually mounted	73
Post of	73
Saluting by, in review	619
Turning out of column in review	620 ; 621
Stains, how removed	1284
Standards and colors	1575
Standing trench	1146
"Star Spangled Banner"	1572
"STAR SPANGLED BANNER" PLAYED AT:	
Funeral	641
Review	624
Statement of clothing charged to enlisted men	904
Stationary targets, firing at	1428
Step, change, how executed	119
Stepping off with left foot	107
Steps and marchings	107 -119
Stings, first aid	1517
Stragglings in marches	1224
Strange country, finding way in	1084
Striking tents	687 ; 690
SUBORDINATES:	
Coöperation	387
Latitude allowed and initiative	384 ; 385 ; 386

SUCCESS IN BATTLE:	
Depends upon leadership, etc.	365
Factors entering into	373 ; 376
Object of military training	50
Principles for increasing probability of, provided for in drill regulations	53
SUCCESSION OF THIN LINES:	
Command for advancing	255
Use in advancing	249
Use and purpose	256
Successive formations, guide toward point of rest	65
Successive movements in double time, base unit marches in quick time	61
Suffocation, first aid	1478
Summary court records	903
Summary of combat principles	550
Sunburn, first aid	1485 ; 1518
Sunstroke	1519
Superiority of fire	414 -438
SUPPORT:	
Artillery	601 -605
Battalion:	
Battalion acting alone in defense	357
Distance from firing line	338
Division of battalion into support and firing line	335
Furnished by battalion	455
None at beginning	339
Position	337
Size	336
Company:	
Captain to look out for major's signals	363
Control by major	263
Duties of officers and sergeants upon joining firing line	266
Formations for	262
Original platoon divisions to be maintained	266
Promptness in reënforcing firing line	265
Reënforcements joining firing line	264
Occupying trenches vacated by firing line, to improve same	476
Of firing line, strength	449 ; 450
Post and strength, in holding attack	500
To cover withdrawal	362
Supporting artillery	434 -437
Supreme will, but one in battle	387
SURPRISE:	
Each commander to guard his command against	442
Human element	92
Protection against, when company is acting alone	26
Suspend firing	193 ; 194
Syphilis	146

T

Tactical exercises, methods of conducting	37
Tactical orders	32
Tactical principles, application of	5
Take arms	16

TAKE INTERVAL:	
Actions of guides and file closers	213
How executed	156
TAKING DISTANCE:	
Actions of guides and file closers	66
How executed	158
"Tanks"	1204
TARGET:	
Action in defense when it disappears	294
Aiming points, use	284
Announced before or after range	181
Allotment to platoon leaders	282
Apportioned by major	340
Assignment by major	281
Change to be avoided	281
Choice of, etc.	422
Designation	201 ; 1445 ; 1447 (a)
Determination of distance to	276
Distribution of fire	282 ; 283 ; 427
Hostile firing line usual target	281 ; 345
Observation of	424 ; 429
Once designated, not changed unless ordered	182
Target practice. See " Rifle training and instruction "	
Target records, company	907
Targets, number hit	1418
TEAMWORK:	
Developed by thorough and uniform training	51
General principles	385 - 391
Technical principles of firing	1409
Telegraph code	866
Telephones in trenches	1171
Tent folding	691
TENT PITCHING:	
All types except shelter and conical wall	688
Conical wall	689
Shelter	681 ; 682
Tent striking	687 ; 690
Terrain exercises	945 ; 949
THE COLOR:	
Cased, defined	659
Meaning of "Color"	658
National, renders no salute	660
Receiving of	669
Salute by regimental	660
Where kept	659
Theoretical instruction, purpose	369
"The Star Spangled Banner," see " Star Spangled Banner "	
THIN LINES SUCCESSION OF:	
Commands for advancing	255
Use and purpose	256
Use in advancing	249
Thoroughness in training	922
"To the Color" sounded at review	624
To the rear, how executed	118
Tourniquet	1481

"Tracking"	1088
Trail, at, (command)	121 (sixth)
Trail from order	139
TRAINING AND INSTRUCTION:	
Art of instruction on varied ground	933
Captain's responsibility for	202
Cheerfulness	930
Clearness	922
Commanding officers accountable for	51
Comradeship	932
Contentment	931
Courage	927
Cover, training in use of	939
Delivery of messages	958
Determination and individual intelligence	924
Fear	926
For battle, simple movements and elastic formations	52
Human element	925
Individual initiative	923
Interest	922
In use of signals to control fire line	55 (d)
Map problems	954
Method and progression	918
Object	50; 917
Of battalions, major responsible for	295
Operating against other troops	941
Practice in commanding mixed squads	940
Principles provided for in Drill Regulations	53
Program	919
Reality	922
Respect	929
Responsibility	921
See, " General Common Sense Principles of Applied	
Minor Tactics "	
Simultaneous instruction and training	920
Surprise	928
Thoroughness	51; 922
Vanity	922
Trajectory	1349
Traveling in strange country	1084
Traverses	1149
Treatment of soldiers	872
TRENCH AND MINE WARFARE:	
Aerial mines	1200
Aids to firing	1209
Asphyxiating gases	1194
Bombs from air-craft	1202
Countermining	1211
Grenades and bombs	1197; 1198; 1199
Helmets	1205
Liquid fire	1196
Masks	1206
Mining	1210
Periscopes	1207
Protection against gases	1195
Protection against hand grenades	1203
Sniperscope	1208
"Tanks"	1204
Winged torpedoes	1201
TRENCHES:	
Located by major	351
Occupied by supports and reserves, to be improved	462
See " Field fortifications "	
Trial shots, determination of range	1395
Trials by court-martial	882

Triangle of sighting	1359
Trigger-squeeze exercise	1370
Troops stable guards	1808
Trous de loup	1184
True meridian	1873
Turning about, mounted officer	74
Turning movements when allowable	458
TURNING ON FIXED PIVOT:	
How executed	164
When used	66
Two's right (left) front into line	235

U

Umpire	55 ; 371
UNFIX BAYONET:	
Krag rifle	694
Springfield rifle	143
Uniform, dignity of	1523
UNIT:	
Attack	342
Fire	287
Units not to be broken up	378
Unload	180 ; 187
Unload, Krag rifle	703
Unnecessary hardship to be avoided	380
Unslung equipment	648
Unslung packs, old equipment	706
Urinal tubs	1244
Use of cover	195 - 199
Use of ground	420 ; 421

V

Valleys determination of range	1395
Variety in instruction	922
Vegetables, distribution of disease	1458
Venereal disease	1466
Verbal orders	393
Vertical clock face system of target designation	1447
Visibility problem	1875
Vision at night	1094
VOLLEY FIRING:	
How executed	189
Use	278

W

Wall tents	688
War game	946 ; 949

Warning calls	692
Watchmen	1781
WATER:	
Distribution of disease	1457
In camp	1253
In trenches	1168
Whistle, long blast	193
Whistle signals	91
Whistles, by whom carried, different tones, etc.	83
Wigwag	862
Will supreme, but one in battle	387
Windage	1384
Winged torpedoes	1201
Wire entanglements	1181 ; 1182 ; 1188
Wire fence, trenches	1183
WITHDRAWAL FROM ACTION:	
Action by commander	549
Covered by support	362
Generally effected at heavy cost	545
Part of line to be withdrawn first	548
Rear guard and distance to be placed between enemy and defeated troops	545
Reserve used to check pursuit	547
Retreating troops to be gotten under control as soon as possible	548
Selection of rendezvous point	549
Under fire	475
Use of artillery, machine guns and cavalry	546
Use of machine guns	557
With dummy (blank or ball) cartridges, load	185
"Without the numbers"	122 (Fifth)
Witness, appearance as	1531
Wood, camping	1252
Work, devolution of	869
Wounded not to be carried back by fighting troops	381
Wounds, first aid	1520
Y	
Yellow fever	1469
Z	
Zero of rifle	1392
Zone of effective fire	1415

[Pg 666]

THE MOSS PUBLICATIONS

OFFICERS' MANUAL	\$2.50
NONCOMMISSIONED OFFICERS' MANUAL	1.50
PRIVATES' MANUAL	1.00
MANUAL OF MILITARY TRAINING	2.25
QUESTIONS ON MANUAL OF MILITARY TRAINING	.50
APPLIED MINOR TACTICS	1.25

FIELD SERVICE		1.25
INFANTRY DRILL REGULATIONS SIMPLIFIED		.75
SPANISH FOR SOLDIERS		1.00
SELF-HELPS FOR THE CITIZEN-SOLDIER		1.25
RIOT DUTY		.50
ARMY CHANGES	Single copies, 50c; annual subscription	1.50
ARMY PAPERWORK		2.00
MILITARY TRAINING FOR BOYS		.50
PEACE AND WAR DUTIES OF THE ENLISTED MAN		.50
TRENCH WARFARE		1.25
QUESTIONS ON INFANTRY DRILL REGULATIONS		.50
COMPANY TRAINING		.50
EXTRACTS FROM ARMY REGULATIONS		1.50
COMBINED ARMY PUBLICATIONS		2.25
QUESTIONS ON COMBINED ARMY PUBLICATIONS		1.25
OUR FLAG AND ITS MESSAGE		.25
WHAT SAMMY'S DOING		.75
ORIGIN AND SIGNIFICANCE OF MILITARY CUSTOMS		.50
ARMY MANUAL FOR MILITARY SURGEONS		2.00
A B C'S OF PERSONAL PREPAREDNESS	\$.50	
Intended to be used with the "Dandy Dummy Gun"	.75	
	————	1.25

(Plus transportation charges on gun.)



PUBLISHERS
GEORGE BANTA PUBLISHING COMPANY
 MENASHA, WISCONSIN

 Banta's Complete Catalogue of Military Books will be mailed on application.



CORONA

The Pen of the Army

Note the ease with which this portable writing machine may be used under service conditions.

Its parts never work loose or drop off. It has no attachments and does not take down.

You can carry Corona anywhere for, case and all, it weighs but 9 lbs. and measures only 10 × 11¼ × 4¼ ins.

Being built almost entirely of aluminum and steel, Corona is practically indestructible.

The Corona Folding Stand adds greatly to the convenience of using Corona in the field. This stand has three telescopic brass legs, stands 24 ins. high and collapses to 10³/₄ ins. It weighs 2 lbs.

Price of Corona and case, \$50
Price of Folding Stand, \$5

Corona Typewriter Co., Inc.

GROTON, NEW YORK



To make your shoes waterproof
To make your shoes soft and comfortable
To make your shoes wear 3 times longer
To keep the harness and saddle in good order

Use Viscol

Viscol makes the leather soft and pliable and also waterproof. Viscolized leather remains soft and pliable under continuous hard service, even when it is worn in salt water or in snow. Viscol is a solution of a rubber-like material which amalgamates with the leather substance and is not driven out of the leather by heat or by water, the way oils are. Its beneficial effect is lasting. Leather that is treated with Viscol wears several times as long as leather that has not been thus treated.

Viscol is sold by many of the Post Exchanges and by most shoe dealers. If you can not procure it at the nearest Post Exchange or from your shoe dealer, write to

VISCOL COMPANY
East Cambridge Boston, Mass.

TROPHIES AND PRIZES For Military, Athletic and Sporting Events

Of Quality as Designed and made for the
U. S. Army
and Navy, West Point Academy and
U. S. Naval Academy

Catalogues and Information upon Request

BAILEY, BANKS & BIDDLE CO.

Diamond Merchants, Jewelers, Silversmiths, Goldsmiths, Heraldists

PHILADELPHIA

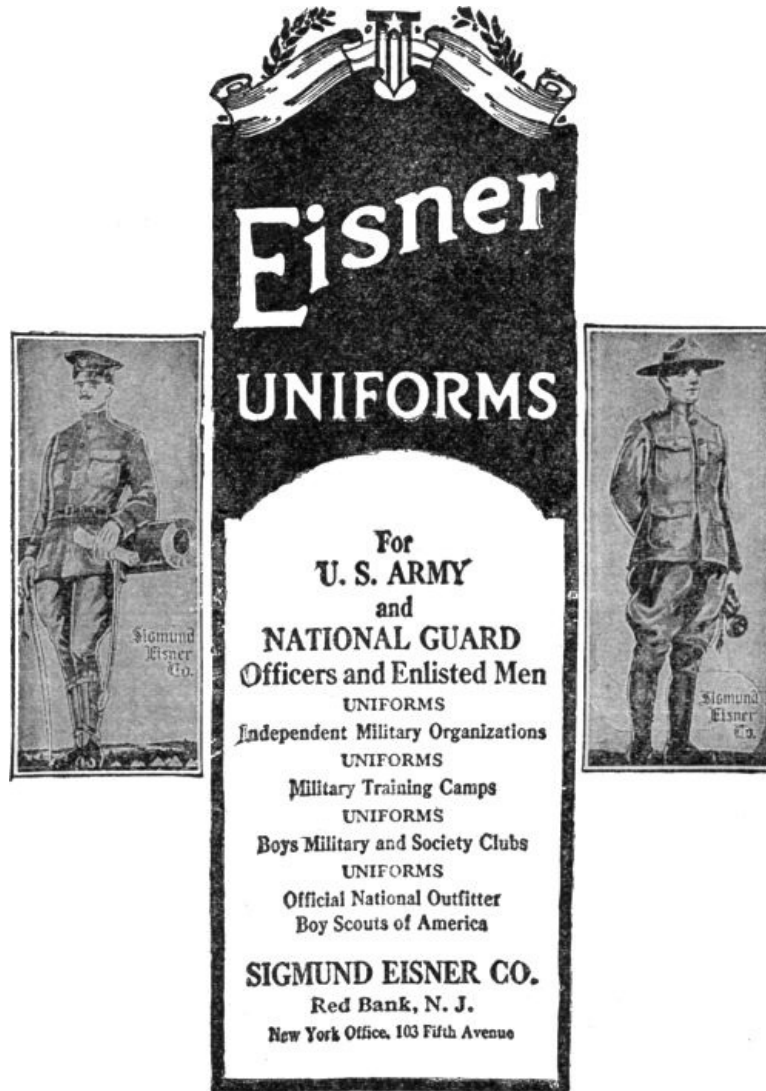

Eisner
UNIFORMS

For
U. S. ARMY
and
NATIONAL GUARD
Officers and Enlisted Men
UNIFORMS
Independent Military Organizations
UNIFORMS
Military Training Camps
UNIFORMS
Boys Military and Society Clubs
UNIFORMS
Official National Outfitter
Boy Scouts of America

SIGMUND EISNER CO.
Red Bank, N. J.
New York Office, 103 Fifth Avenue

COMFORT YOUR FEET

Keep shoes, puttees and all leather accouterments soft, water proof and pliable with 3-in-One. Not sticky or greasy. Contains no acid. After a march or tiresome drill, rub

3-IN-ONE OIL

on your feet—wonderful how it helps take the smart out!

Use 3-in-One on gun and revolver—prevents rust and keeps them in order for inspection. Use on bayonet and side arms, too.

3-in-One will make

your gun work with out sticking or jamming. Best shots use and recommend it. Put 3-in-One on your razor strop; also draw razor blade between thumb and finger moistened with 3-in-One after shaving. You'll shave easier.



Sold at Post Exchanges and Ship's

Stores: 1-oz. bottle, 10c; 3-oz., 25c; 8-oz. (½ pt.) 50c. Also in HANDY Oil Cans, 3-oz. 25c. *Avoid substitutes.*

FREE a generous sample and Dictionary of uses

THREE-IN-ONE OIL CO., 42 DAL, Broadway, New York

Outdoor Equipage

MEYER'S MILITARY SHOPS

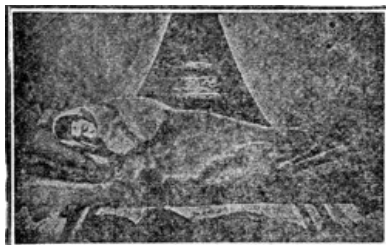

Riding Breeches and Habits

TAILORS

F Street, between 13th and 14th Sts. N. W.
WASHINGTON, D. C.

*Complete Outdoor Equipage
Ready to Wear
For Men, Women, and Children*

RIDING BREECHES, PUTTEE LEGGINS, NORFOLK JACKETS,
HUNTING CLOTHES, BOOTS AND SHOES, MIDDY BLOUSE AND SKIRTS, TENTS AND SLEEPING BAGS, RIDING SKIRTS AND NORFOLK JACKETS, MOCCASINS

Write for Catalogue

Visit Our Camp Rooms When in Washington

RIDABOCK & COMPANY

149-151 West 36th St., New York

U. S. Army, National Guard Officers' Uniforms and Equipments

Military School Uniforms and Equipments

Military Training Camp Outfits

Military Supplies, Military Textbooks

Individual Departments and Workshops for the Respective Grades of Uniforms.

USED BY UNCLE SAM'S EXPERT RIFLEMEN



**Hoppe's
Nitro Powder Solvent No.
9**

Trade Mark Registered

**For Cleaning High Power (Springfield)
Rifles, Revolvers and Firearms of All
Kinds**

A compound that will remove the residue of any high-power powder, including Black Powder. It will neutralize and residue and loosen metal fouling and leading that may be left in the barrel after cleaning, and prevent Pitting. No. 9 is the only Rifle cleaning Solvent that will remove Rust, Metal Fouling and Leading. For cleaning the .22 cal. Rifles, Revolvers and Automatic Pistols it has no equal. Nitro Powder

Solvent No. 9 is endorsed by the most prominent Riflemen in America. Used by U. S. Rifle Teams, and at Buenos Ayres, Argentine Matches. No Rifleman or Quartermaster's Department should be without it.

Sold by Sporting Goods Dealers and at Post Exchanges

**FRANK A. HOPPE, Sole
Manufacturer,**

Station O, Philadelphia, U. S. A.

ESTABLISHED 1854

**B. Pasquale
Company**

115-117 Post St.

SAN FRANCISCO, CAL.

The Only Manufacturers of
**Army and Navy Equipments
and Uniforms on the Pacific Coast**

"QUALITY AND FIT GUARANTEED"

(Write for Catalogue)

THE MILITARY HISTORIAN AND ECONOMIST

QUARTERLY

Harvard University Press, Cambridge, Mass.

Subscription, \$3.00 per annum.

Edited by MAJOR A. L. CONGER, U. S. A., and PROFESSOR R. M. JOHNSTON, Harvard University. Advisory Board: General J. F. Morrison, U. S. A., Colonel J. W. McAndrew, U. S. A., Professors C. J. Bullock, A. Bushnell Hart, O. M. W. Sprague, and Justin H. Smith, Esq.

Original articles and notes on military history, the Conduct of War, Strategy, Tactics. Military economics by the best American and foreign authorities.

CLAUSEWITZ TO DATE

Edited by R. M. JOHNSTON

Synopsis of the views of Clausewitz with selected quotations from the best military theorists, systematically modernized.

The volume measures only $1\frac{3}{4} \times 2\frac{1}{2}$ inches.

Field service binding. *Price, postpaid \$1.00.*

THE MILITARY HISTORIAN AND ECONOMIST

275 Widener Hall

CAMBRIDGE,
MASSACHUSETTS

TRANSCRIBER'S NOTE.

Irregularities within the original book have been preserved, notably:

Part I has appendices A, B and D. There is no Appendix C.

Part I Chapter I contains plates II, III and VI. Plates I, IV and V are not present nor referenced.

References to other paragraphs within the text mostly use the book paragraph number. However, there are some cases where the paragraph number relates to the source document paragraph number (in brackets at the end of the paragraph)—these have been left as shown in the book. The link in the html version does, however, point to the intended paragraph.

Spelling variants (e. g. reinforce vs reënforce) have been preserved.

The 'pointing finger' picture has been transcribed as --> in the text version.

Brackets have been added as necessary to equations to aid clarity.

For consistency, subheadings which originally appeared next to a paragraph number have been extracted out to the line above (i. e. they do not appear on the same line as the paragraph number in this transcription.) Affected paragraphs are:

[817](#)

[818](#)

[826](#)

[828-34](#)

[836-47](#)
[860](#)
[862](#)
[864-6](#)
[1016-9](#)
[1034-45](#)
[1078](#)
[1277](#)
[1320](#)
[1340-1](#)
[1352-3](#)
[1356](#)
[1358-65](#)
[1367-70](#)
[1372](#)
[1376](#)
[1379-80](#)
[1383](#)

*** END OF THE PROJECT GUTENBERG EBOOK MANUAL OF MILITARY TRAINING ***

Updated editions will replace the previous one—the old editions will be renamed.

Creating the works from print editions not protected by U.S. copyright law means that no one owns a United States copyright in these works, so the Foundation (and you!) can copy and distribute it in the United States without permission and without paying copyright royalties. Special rules, set forth in the General Terms of Use part of this license, apply to copying and distributing Project Gutenberg™ electronic works to protect the PROJECT GUTENBERG™ concept and trademark. Project Gutenberg is a registered trademark, and may not be used if you charge for an eBook, except by following the terms of the trademark license, including paying royalties for use of the Project Gutenberg trademark. If you do not charge anything for copies of this eBook, complying with the trademark license is very easy. You may use this eBook for nearly any purpose such as creation of derivative works, reports, performances and research. Project Gutenberg eBooks may be modified and printed and given away—you may do practically ANYTHING in the United States with eBooks not protected by U.S. copyright law. Redistribution is subject to the trademark license, especially commercial redistribution.

START: FULL LICENSE
THE FULL PROJECT GUTENBERG LICENSE
PLEASE READ THIS BEFORE YOU DISTRIBUTE OR USE THIS WORK

To protect the Project Gutenberg™ mission of promoting the free distribution of electronic works, by using or distributing this work (or any other work associated in any way with the phrase “Project Gutenberg”), you agree to comply with all the terms of the Full Project Gutenberg™ License available with this file or online at www.gutenberg.org/license.

Section 1. General Terms of Use and Redistributing Project Gutenberg™ electronic works

1.A. By reading or using any part of this Project Gutenberg™ electronic work, you indicate that you have read, understand, agree to and accept all the terms of this license and intellectual property (trademark/copyright) agreement. If you do not agree to abide by all the terms of this agreement, you must cease using and return or destroy all copies of Project Gutenberg™ electronic works in your possession. If you paid a fee for obtaining a copy of or access to a Project Gutenberg™ electronic work and you do not agree to be bound by the terms of this agreement, you may obtain a refund from the person or entity to whom you paid the fee as set forth in paragraph 1.E.8.

1.B. “Project Gutenberg” is a registered trademark. It may only be used on or associated in any way with an electronic work by people who agree to be bound by the terms of this agreement. There are a few things that you can do with most Project Gutenberg™ electronic works even without complying with the full terms of this agreement. See paragraph 1.C below. There are a lot of things you can do with Project Gutenberg™ electronic works if you follow the terms of this agreement and help preserve free future access to Project Gutenberg™ electronic works. See paragraph 1.E below.

1.C. The Project Gutenberg Literary Archive Foundation (“the Foundation” or PGLAF), owns a compilation copyright in the collection of Project Gutenberg™ electronic works. Nearly all the individual works in the collection are in the public domain in the United States. If an individual work is unprotected by copyright law in the United States and you are located in the United States, we do not claim a right to prevent you from copying, distributing, performing, displaying or creating derivative works based on the work as long as all

references to Project Gutenberg are removed. Of course, we hope that you will support the Project Gutenberg™ mission of promoting free access to electronic works by freely sharing Project Gutenberg™ works in compliance with the terms of this agreement for keeping the Project Gutenberg™ name associated with the work. You can easily comply with the terms of this agreement by keeping this work in the same format with its attached full Project Gutenberg™ License when you share it without charge with others.

1.D. The copyright laws of the place where you are located also govern what you can do with this work. Copyright laws in most countries are in a constant state of change. If you are outside the United States, check the laws of your country in addition to the terms of this agreement before downloading, copying, displaying, performing, distributing or creating derivative works based on this work or any other Project Gutenberg™ work. The Foundation makes no representations concerning the copyright status of any work in any country other than the United States.

1.E. Unless you have removed all references to Project Gutenberg:

1.E.1. The following sentence, with active links to, or other immediate access to, the full Project Gutenberg™ License must appear prominently whenever any copy of a Project Gutenberg™ work (any work on which the phrase “Project Gutenberg” appears, or with which the phrase “Project Gutenberg” is associated) is accessed, displayed, performed, viewed, copied or distributed:

This eBook is for the use of anyone anywhere in the United States and most other parts of the world at no cost and with almost no restrictions whatsoever. You may copy it, give it away or re-use it under the terms of the Project Gutenberg License included with this eBook or online at www.gutenberg.org. If you are not located in the United States, you will have to check the laws of the country where you are located before using this eBook.

1.E.2. If an individual Project Gutenberg™ electronic work is derived from texts not protected by U.S. copyright law (does not contain a notice indicating that it is posted with permission of the copyright holder), the work can be copied and distributed to anyone in the United States without paying any fees or charges. If you are redistributing or providing access to a work with the phrase “Project Gutenberg” associated with or appearing on the work, you must comply either with the requirements of paragraphs 1.E.1 through 1.E.7 or obtain permission for the use of the work and the Project Gutenberg™ trademark as set forth in paragraphs 1.E.8 or 1.E.9.

1.E.3. If an individual Project Gutenberg™ electronic work is posted with the permission of the copyright holder, your use and distribution must comply with both paragraphs 1.E.1 through 1.E.7 and any additional terms imposed by the copyright holder. Additional terms will be linked to the Project Gutenberg™ License for all works posted with the permission of the copyright holder found at the beginning of this work.

1.E.4. Do not unlink or detach or remove the full Project Gutenberg™ License terms from this work, or any files containing a part of this work or any other work associated with Project Gutenberg™.

1.E.5. Do not copy, display, perform, distribute or redistribute this electronic work, or any part of this electronic work, without prominently displaying the sentence set forth in paragraph 1.E.1 with active links or immediate access to the full terms of the Project Gutenberg™ License.

1.E.6. You may convert to and distribute this work in any binary, compressed, marked up, nonproprietary or proprietary form, including any word processing or hypertext form. However, if you provide access to or distribute copies of a Project Gutenberg™ work in a format other than “Plain Vanilla ASCII” or other format used in the official version posted on the official Project Gutenberg™ website (www.gutenberg.org), you must, at no additional cost, fee or expense to the user, provide a copy, a means of exporting a copy, or a means of obtaining a copy upon request, of the work in its original “Plain Vanilla ASCII” or other form. Any alternate format must include the full Project Gutenberg™ License as specified in paragraph 1.E.1.

1.E.7. Do not charge a fee for access to, viewing, displaying, performing, copying or distributing any Project Gutenberg™ works unless you comply with paragraph 1.E.8 or 1.E.9.

1.E.8. You may charge a reasonable fee for copies of or providing access to or distributing Project Gutenberg™ electronic works provided that:

- You pay a royalty fee of 20% of the gross profits you derive from the use of Project Gutenberg™ works calculated using the method you already use to calculate your applicable taxes. The fee is owed to the owner of the Project Gutenberg™ trademark, but he has agreed to donate royalties under this paragraph to the Project Gutenberg Literary Archive Foundation. Royalty payments must be paid within 60 days following each date on which you prepare (or are legally required to prepare) your periodic tax returns. Royalty payments

should be clearly marked as such and sent to the Project Gutenberg Literary Archive Foundation at the address specified in Section 4, "Information about donations to the Project Gutenberg Literary Archive Foundation."

- You provide a full refund of any money paid by a user who notifies you in writing (or by e-mail) within 30 days of receipt that s/he does not agree to the terms of the full Project Gutenberg™ License. You must require such a user to return or destroy all copies of the works possessed in a physical medium and discontinue all use of and all access to other copies of Project Gutenberg™ works.
- You provide, in accordance with paragraph 1.F.3, a full refund of any money paid for a work or a replacement copy, if a defect in the electronic work is discovered and reported to you within 90 days of receipt of the work.
- You comply with all other terms of this agreement for free distribution of Project Gutenberg™ works.

1.E.9. If you wish to charge a fee or distribute a Project Gutenberg™ electronic work or group of works on different terms than are set forth in this agreement, you must obtain permission in writing from the Project Gutenberg Literary Archive Foundation, the manager of the Project Gutenberg™ trademark. Contact the Foundation as set forth in Section 3 below.

1.F.

1.F.1. Project Gutenberg volunteers and employees expend considerable effort to identify, do copyright research on, transcribe and proofread works not protected by U.S. copyright law in creating the Project Gutenberg™ collection. Despite these efforts, Project Gutenberg™ electronic works, and the medium on which they may be stored, may contain "Defects," such as, but not limited to, incomplete, inaccurate or corrupt data, transcription errors, a copyright or other intellectual property infringement, a defective or damaged disk or other medium, a computer virus, or computer codes that damage or cannot be read by your equipment.

1.F.2. LIMITED WARRANTY, DISCLAIMER OF DAMAGES - Except for the "Right of Replacement or Refund" described in paragraph 1.F.3, the Project Gutenberg Literary Archive Foundation, the owner of the Project Gutenberg™ trademark, and any other party distributing a Project Gutenberg™ electronic work under this agreement, disclaim all liability to you for damages, costs and expenses, including legal fees. YOU AGREE THAT YOU HAVE NO REMEDIES FOR NEGLIGENCE, STRICT LIABILITY, BREACH OF WARRANTY OR BREACH OF CONTRACT EXCEPT THOSE PROVIDED IN PARAGRAPH 1.F.3. YOU AGREE THAT THE FOUNDATION, THE TRADEMARK OWNER, AND ANY DISTRIBUTOR UNDER THIS AGREEMENT WILL NOT BE LIABLE TO YOU FOR ACTUAL, DIRECT, INDIRECT, CONSEQUENTIAL, PUNITIVE OR INCIDENTAL DAMAGES EVEN IF YOU GIVE NOTICE OF THE POSSIBILITY OF SUCH DAMAGE.

1.F.3. LIMITED RIGHT OF REPLACEMENT OR REFUND - If you discover a defect in this electronic work within 90 days of receiving it, you can receive a refund of the money (if any) you paid for it by sending a written explanation to the person you received the work from. If you received the work on a physical medium, you must return the medium with your written explanation. The person or entity that provided you with the defective work may elect to provide a replacement copy in lieu of a refund. If you received the work electronically, the person or entity providing it to you may choose to give you a second opportunity to receive the work electronically in lieu of a refund. If the second copy is also defective, you may demand a refund in writing without further opportunities to fix the problem.

1.F.4. Except for the limited right of replacement or refund set forth in paragraph 1.F.3, this work is provided to you 'AS-IS', WITH NO OTHER WARRANTIES OF ANY KIND, EXPRESS OR IMPLIED, INCLUDING BUT NOT LIMITED TO WARRANTIES OF MERCHANTABILITY OR FITNESS FOR ANY PURPOSE.

1.F.5. Some states do not allow disclaimers of certain implied warranties or the exclusion or limitation of certain types of damages. If any disclaimer or limitation set forth in this agreement violates the law of the state applicable to this agreement, the agreement shall be interpreted to make the maximum disclaimer or limitation permitted by the applicable state law. The invalidity or unenforceability of any provision of this agreement shall not void the remaining provisions.

1.F.6. INDEMNITY - You agree to indemnify and hold the Foundation, the trademark owner, any agent or employee of the Foundation, anyone providing copies of Project Gutenberg™ electronic works in accordance with this agreement, and any volunteers associated with the production, promotion and distribution of Project Gutenberg™ electronic works, harmless from all liability, costs and expenses, including legal fees, that arise directly or indirectly from any of the following which you do or cause to occur: (a) distribution of this or any Project Gutenberg™ work, (b) alteration, modification, or additions or deletions to any Project Gutenberg™ work, and (c) any Defect you cause.

Section 2. Information about the Mission of Project Gutenberg™

Project Gutenberg™ is synonymous with the free distribution of electronic works in formats readable by the widest variety of computers including obsolete, old, middle-aged and new computers. It exists because of the efforts of hundreds of volunteers and donations from people in all walks of life.

Volunteers and financial support to provide volunteers with the assistance they need are critical to reaching Project Gutenberg™'s goals and ensuring that the Project Gutenberg™ collection will remain freely available for generations to come. In 2001, the Project Gutenberg Literary Archive Foundation was created to provide a secure and permanent future for Project Gutenberg™ and future generations. To learn more about the Project Gutenberg Literary Archive Foundation and how your efforts and donations can help, see Sections 3 and 4 and the Foundation information page at www.gutenberg.org.

Section 3. Information about the Project Gutenberg Literary Archive Foundation

The Project Gutenberg Literary Archive Foundation is a non-profit 501(c)(3) educational corporation organized under the laws of the state of Mississippi and granted tax exempt status by the Internal Revenue Service. The Foundation's EIN or federal tax identification number is 64-6221541. Contributions to the Project Gutenberg Literary Archive Foundation are tax deductible to the full extent permitted by U.S. federal laws and your state's laws.

The Foundation's business office is located at 809 North 1500 West, Salt Lake City, UT 84116, (801) 596-1887. Email contact links and up to date contact information can be found at the Foundation's website and official page at www.gutenberg.org/contact

Section 4. Information about Donations to the Project Gutenberg Literary Archive Foundation

Project Gutenberg™ depends upon and cannot survive without widespread public support and donations to carry out its mission of increasing the number of public domain and licensed works that can be freely distributed in machine-readable form accessible by the widest array of equipment including outdated equipment. Many small donations (\$1 to \$5,000) are particularly important to maintaining tax exempt status with the IRS.

The Foundation is committed to complying with the laws regulating charities and charitable donations in all 50 states of the United States. Compliance requirements are not uniform and it takes a considerable effort, much paperwork and many fees to meet and keep up with these requirements. We do not solicit donations in locations where we have not received written confirmation of compliance. To SEND DONATIONS or determine the status of compliance for any particular state visit www.gutenberg.org/donate.

While we cannot and do not solicit contributions from states where we have not met the solicitation requirements, we know of no prohibition against accepting unsolicited donations from donors in such states who approach us with offers to donate.

International donations are gratefully accepted, but we cannot make any statements concerning tax treatment of donations received from outside the United States. U.S. laws alone swamp our small staff.

Please check the Project Gutenberg web pages for current donation methods and addresses. Donations are accepted in a number of other ways including checks, online payments and credit card donations. To donate, please visit: www.gutenberg.org/donate

Section 5. General Information About Project Gutenberg™ electronic works

Professor Michael S. Hart was the originator of the Project Gutenberg™ concept of a library of electronic works that could be freely shared with anyone. For forty years, he produced and distributed Project Gutenberg™ eBooks with only a loose network of volunteer support.

Project Gutenberg™ eBooks are often created from several printed editions, all of which are confirmed as not protected by copyright in the U.S. unless a copyright notice is included. Thus, we do not necessarily keep eBooks in compliance with any particular paper edition.

Most people start at our website which has the main PG search facility: www.gutenberg.org.

This website includes information about Project Gutenberg™, including how to make donations to the Project Gutenberg Literary Archive Foundation, how to help produce our new eBooks, and how to subscribe to our email newsletter to hear about new eBooks.