

The Project Gutenberg eBook of Common Science, by Carleton Washburne and John W. Ritchie

This ebook is for the use of anyone anywhere in the United States and most other parts of the world at no cost and with almost no restrictions whatsoever. You may copy it, give it away or re-use it under the terms of the Project Gutenberg License included with this ebook or online at www.gutenberg.org. If you are not located in the United States, you'll have to check the laws of the country where you are located before using this eBook.

Title: Common Science

Author: Carleton Washburne

Editor: John W. Ritchie

Release Date: August 28, 2009 [EBook #29838]

Language: English

Credits: Produced by David Garcia, Simon Gardner and the Online Distributed Proofreading Team at <https://www.pgdp.net>

*** START OF THE PROJECT GUTENBERG EBOOK COMMON SCIENCE ***

Transcriber's Note:

Minor inconsistencies in spelling, punctuation and formatting are retained as in the original. Where detailed corrections have been made on the text these are listed at the [end of this document](#).

Disclaimer:

This is a work of historical interest only and much of the scientific content has been superseded. There are numerous experiments described in this book which are hazardous and should not be attempted. Advice given on handling toxic substances, electrical apparatus etc. should not be followed.

Do not try this at home!

[pg i]

COMMON SCIENCE

[pg ii]

NEW-WORLD SCIENCE SERIES

Edited by John W. Ritchie

SCIENCE FOR BEGINNERS

By *Delos Fall*

TREES, STARS, AND BIRDS

By *Edwin Lincoln Moseley*

COMMON SCIENCE

By *Carleton W. Washburne*

Human Physiology

By *John W. Ritchie*

SANITATION AND PHYSIOLOGY

By *John W. Ritchie*

LABORATORY MANUAL FOR USE WITH "HUMAN PHYSIOLOGY"

By *Carl Hartman*

EXERCISE AND REVIEW BOOK IN BIOLOGY
By *J. G. Blaisdell*

PERSONAL HYGIENE AND HOME NURSING
By *Louisa C. Lippitt*

SCIENCE OF PLANT LIFE
By *Edgar Nelson Transeau*

ZOOLOGY
By *T. D. A. Cockerell*

EXPERIMENTAL ORGANIC CHEMISTRY
By *Augustus P. West*

[pg iii]

NEW-WORLD SCIENCE SERIES

Edited by John W. Ritchie

COMMON SCIENCE

by

Carleton W. Washburne

*Superintendent of Schools, Winnetka, Illinois
Formerly Supervisor in Physical Sciences and Instructor in Educational Psychology
State Normal School
San Francisco, California*

ILLUSTRATED

WITH PHOTOGRAPHS AND DRAWINGS

Yonkers-on-Hudson, New York

WORLD BOOK COMPANY

1921

[pg iv]

WORLD BOOK COMPANY

THE HOUSE OF APPLIED KNOWLEDGE

Established, 1905, by Caspar W. Hodgson

YONKERS-ON-HUDSON, NEW YORK

2126 PRAIRIE AVENUE, CHICAGO

One of the results of the World War has been a widespread desire to see the forces of science which proved so mighty in destruction employed generally and systematically for the promotion of human welfare. World Book Company, whose motto is The Application of the World's Knowledge to the World's Needs, has been much in sympathy with the movement to make science an integral part of our elementary education, so that all our people from the highest to the lowest will be able to use it for themselves and to appreciate the possibilities of ameliorating the conditions of human life by its application to the problems that confront us. We count it our good fortune, therefore, that we are able at this time to offer *Common Science* to the schools. It is one of the new type of texts that are built on educational research and not by guess, and we believe it to be a substantial contribution to the teaching of the subject.

NWSS:WCS-2

Copyright, 1920, by World Book Company
Copyright in Great Britain
All rights reserved

[pg v]

PREFACE

A collection of about 2000 questions asked by children forms the foundation on which this book is built. Rather than decide what it is that children ought to know, or what knowledge could best be fitted into some educational theory, an attempt was made to find out what children want to know. The obvious way to discover this was to let them ask questions.

The questions collected were asked by several hundred children in the upper elementary grades, over a period of a year and a half. They were then sorted and classified according to the scientific principles needed in order to answer them. These principles constitute the skeleton of this course. The questions gave a very fair indication of the parts of science in which children are most interested. Physics, in simple, qualitative form,—not mathematical physics, of course,—comes first; astronomy next; chemistry, geology, and certain forms of physical geography (weather, volcanoes, earthquakes, etc.) come third; biology, with physiology and hygiene, is a close fourth; and nature study, in the ordinary school sense of the term, comes in hardly at all.

The chapter headings of this book might indicate that the course has to do with physics and chemistry only. This is because general physical and chemical principles form a unifying and inclusive matrix for the mass of applications. But the examples and descriptions throughout the book include physical geography and the life sciences. Descriptive astronomy and geology have, however, been omitted. These two subjects can be best grasped in a reading course and field trips, and they have been incorporated in separate books.

[pg vi]

The best method of presenting the principles to the children was the next problem. The study of the questions asked had shown that the children's interests were centered in the explanation of a wide variety of familiar facts in the world about them. It seemed evident, therefore, that a presentation of the principles that would answer the questions asked would be most interesting to the child. Experience with many different classes had shown that it is not necessary to subordinate these explanations of what children really wish to know to other methods of instruction of doubtful interest value.

Obviously the quantitative methods of the high school and college were unsuitable for pupils of this age. We want children to be attracted to science, not repelled by it. The assumption that scientific method can be taught to children by making them perform uninteresting, quantitative experiments in an effort to get a result that will tally with that given in the textbook is so palpably unfounded that it is scarcely necessary to prove its failure by pointing to the very unscientific product of most of our high school science laboratories.

After a good deal of experimenting with children in a number of science classes, the method followed in this book was developed. Briefly, it is as follows:

[pg vii]

At the head of each section are several of the questions which, in part, prompted the writing of the section. The purpose of these is to let the children know definitely what their goal is when they begin a section. The fact that the questions had their origin in the minds of children gives reasonable assurance that they will to some extent appeal to children. These questions in effect state the problems which the section helps to solve.

Following the questions are some introductory paragraphs for arousing interest in the problem at hand,—for motivating the child further. These paragraphs are frequently a narrative description containing a good many dramatic elements, and are written in conversational style. The purpose is to awaken the child's imagination and to make clear the intimate part which the principle under consideration plays in his own life. When a principle is universal, like gravity, it is best brought out by imagining what would happen if it ceased to exist. If a principle is particular to certain substances, like elasticity, it sometimes can be brought out vividly by imagining what would happen if it were universal. Contrast is essential to consciousness. To contrast a condition that is very common with an imagined condition that is different brings the former into vivid consciousness. Incidentally, it arouses real interest. The story-like introduction to many sections is not a sugar coating to make the child swallow a bitter pill. It is a psychologically sound method of bringing out the essential and dramatic features of a principle which is in itself interesting, once the child has grasped it.

Another means for motivating the work in certain cases consists in first doing a dramatic experiment that will arouse the pupil's interest and curiosity. Still another consists in merely calling the child's attention to the practical value of the principle.

[pg viii]

Following these various means for getting the pupil's interest, there are usually some experiments designed to help him solve his problem. The experiments are made as simple and interesting as possible. They usually require very inexpensive apparatus and are chosen or invented both for their interest value and their content value.

With an explanation of the experiments and the questions that arise, a principle is made clear. Then the pupil is given an opportunity to apply the principle in making intelligible some common fact, if the principle has only intelligence value; or he is asked to apply the principle to the solution of a practical problem where the principle also has utility value.

The "inference exercises" which follow each section after the first two consist of statements of

well-known facts explainable in terms of some of the principles which precede them. They involve a constant review of the work which has gone before, a review which nevertheless is new work—they review the principles by giving them new applications. Furthermore, they give the pupil very definite training in explaining the common things around him.

For four years a mimeographed edition of this book has been used in the elementary department of the San Francisco State Normal School. During that time various normal students have tried it in public school classes in and around San Francisco and Oakland, and it has recently been used in Winnetka, Illinois. It has been twice revised throughout in response to needs shown by this use.

The book has proved itself adaptable to either an individual system of instruction or the usual class methods.

[pg ix]

TO THE TEACHER

Do not test the children on the narrative description which introduces most sections, nor require them to recite on it. It is there merely to arouse their interest, and that is likely to be checked if they think it is a lesson to be learned. It is not at all necessary for them to know everything in the introductory parts of each section. If the children are interested, they will remember what is valuable to them; if they are not, do not prolong the agony. The questions which accompany and follow the experiments, the applications or required explanations at the ends of the sections, and the extensive inference exercises, form an ample test of the child's grasp of the principles under discussion.

It is not necessary to have the children write up their experiments. The experiments are a means to an end. The end is the application of the principles to everyday facts. If the children can make these applications, it does not matter how much of the actual experiments they remember.

If possible, the experiments should be done by the pupils individually or in couples, in a school laboratory. Where this cannot be done, almost all the experiments can be demonstrated from the teacher's desk if electricity, water, and gas are to be had. Alcohol lamps can be substituted for gas, but they are less satisfactory.

It is a good plan to have pupils report additional exemplifications of each principle from their home or play life, and in a quick oral review to let the rest of the class name the principles back of each example.

[pg x]

This course is so arranged that it can be used according to the regular class system of instruction, or according to the individual system where each child does his own work at his natural rate of progress. The children can carry on the work with almost no assistance from the teacher, if provision is made for their doing the experiments themselves and for their writing the answers to the inference exercises. When the individual system is used, the children may write the inference exercises, or they may use them as a basis for study and recite only a few to the teacher by way of test. In the elementary department of the San Francisco State Normal School, where the individual system is used, the latter method is in operation. The teacher has a card for each pupil, each card containing a mimeographed list of the principles, with a blank after each. Whenever a pupil correctly explains an example, a figure 1 is placed in the blank following that principle; when he misapplies a principle, or fails to apply it, an x is placed after it. When there are four successive 1's after any principle, the teacher no longer includes that principle in testing that child. In this way the number of inference exercises on which she hears any one individual recite is greatly reduced. This plan would probably have to be altered in order to adapt it to particular conditions.

The Socratic method can be employed to great advantage in handling difficult inferences. The children discuss in class the principle under which an inference comes, and the teacher guides the discussion, when necessary, by skillfully placed questions designed to bring the essential problems into relief.¹

Footnote 1: At the California State Normal School in San Francisco, this course in general science is usually preceded by one in "introductory science."

[pg xi]

The chapters and sections in this book are not of even length. In order to preserve the unity of subject matter, it was felt desirable to divide the book according to subjects rather than according to daily lessons. The varying lengths of recitation periods in different schools, and the adaptation of the course to individual instruction as well as to class work, also made a division into lessons impracticable. Each teacher will soon discover about how much matter her class, if she uses the class method, can take each day. Probably the average section will require about 2 days to cover; the longest sections, 5 days. The entire course should easily be covered in one year with recitations of about 25 minutes daily. Two 50-minute periods a week give a better division of time and also ought to finish the course in a year. Under the individual system, the slowest diligent children finish in 7 or 8 school months, working 4 half-hours weekly. The fastest do it in about one third that time.

Upon receipt of 20 cents, the publishers will send a manual prepared by the author, containing

full instructions as to the organization and equipment of the laboratory or demonstration desk, complete lists of apparatus and material needed, and directions for the construction of a chemical laboratory.

The latter is a laboratory course in which the children are turned loose among all sorts of interesting materials and apparatus,—kaleidoscope, microscope, electric bell, toy motor, chemicals that effervesce or change color when put together, soft glass tubing to mold and blow, etc. The teacher demonstrates various experiments from time to time to show the children what can be done with these things, but the children are left free to investigate to their heart's content. There is no teaching in this introductory course other than brief answers to questions. The astronomy and geology reading usually accompany the work in introductory science.

[pg xii]

ACKNOWLEDGMENTS

To Frederic Burk, president of the San Francisco State Normal School, I am most under obligation in connection with the preparation of this book. His ideas inspired it, and his dynamic criticism did much toward shaping it. My wife, Heluiz Chandler Washburne, gave invaluable help throughout the work, especially in the present revision of the course. One of my co-workers on the Normal School faculty, Miss Louise Mohr, rendered much assistance in the classification and selection of inferences. Miss Beatrice Harper assisted in the preparation of the tables of supplies and apparatus, published in the manual to accompany this book. And I wish to thank the children of the Normal School for their patience and cooperation in posing for the photographs. The photographs are by Joseph Marron.

[pg xiii]

CONTENTS

CHAPTER	PAGE
1. GRAVITATION	1
1. A real place where things weigh nothing and where there is no up or down	1
2. "Water seeks its own level"	6
3. The sea of compressed air in which we live: Air pressure	10
4. Sinking and floating: Displacement	23
5. How things are kept from toppling over: Stability	29
2. MOLECULAR ATTRACTION	36
6. How liquids are absorbed: Capillary attraction	36
7. How things stick to one another: Adhesion	41
8. The force that makes a thing hold together: Cohesion	44
9. Friction	49
3. CONSERVATION OF ENERGY	57
10. Levers	57
11. Inertia	66
12. Centrifugal force	72
13. Action and reaction	77
14. Elasticity	82
4. HEAT	88
15. Heat makes things expand	88
16. Cooling from expansion	94
17. Freezing and melting	96
18. Evaporation	100
19. Boiling and condensing	107
20. Conduction of heat and convection	116
5. RADIANT HEAT AND LIGHT	122
21. How heat gets here from the sun; why things glow when they become very hot	122
22. Reflection	129
23. The bending of light: Refraction	136
24. Focus	142
25. Magnification	150
26. Scattering of light: Diffusion of light	158
27. Color	161
6. SOUND	174
28. What sound is	174
29. Echoes	183

	30. Pitch	185
7.	MAGNETISM AND ELECTRICITY	190
	31. Magnets; the compass	190
	32. Static electricity	196
8.	ELECTRICITY	203
	33. Making electricity flow	203
	34. Conduction of electricity	213
	35. Complete circuits	219
	36. Grounded circuits	225
	37. Resistance	229
	38. The electric arc	233
	39. Short circuits and fuses	240
	40. Electromagnets	247
9.	MINGLING OF MOLECULES	259
	41. Solutions and emulsions	259
	42. Crystals	265
	43. Diffusion	268
	44. Clouds, rain, and dew: Humidity	274
	45. Softening due to oil or water	290
10.	CHEMICAL CHANGE AND ENERGY	293
	46. What things are made of: Elements	293
	47. Burning: Oxidation	312
	48. Chemical change caused by heat	323
	49. Chemical change caused by light	326
	50. Chemical change caused by electricity	335
	51. Chemical change releases energy	340
	52. Explosions	342
11.	SOLUTION AND CHEMICAL ACTION	349
	53. Chemical change helped by solution	349
	54. Acids	351
	55. Bases	355
	56. Neutralization	360
	57. Effervescence	365
12.	ANALYSIS	370
	58. Analysis	370
APPENDIXES:		
	A. The Electrical Apparatus	379
	B. Construction of the Cigar-box Telegraph	381
INDEX		383

COMMON SCIENCE

CHAPTER ONE

GRAVITATION

SECTION 1. *A real place where things weigh nothing and where there is no up or down.*

Why is it that the oceans do not flow off the earth?
 What is gravity?
 What is "down," and what is "up"?

There is a place where nothing has weight; where there is no "up" or "down"; where nothing ever falls; and where, if people were there, they would float about with their heads pointing in all directions. This is not a fairy tale; every word of it is scientifically true. If we had some way of flying straight toward the sun about 160,000 miles, we should really reach this strange place.

Let us pretend that we can do it. Suppose we have built a machine that can fly far out from the earth through space (of course no one has really ever invented such a machine). And since the place is far beyond the air that surrounds the earth, let us imagine that we have fitted out the air-tight cabin of our machine with plenty of air to breathe, and with food and everything we need for living. We shall picture it something like the cabin of an ocean steamer. And let us pretend that we have just arrived at the place where things weigh nothing:

When you try to walk, you glide toward the ceiling of the cabin and do not stop before your head bumps against it. If you push on the ceiling, you float back toward the floor. But you cannot tell whether the floor is above or below, because you have no idea as to which way is up and which way is down.

As a matter of fact there is no up or down. You discover this quickly enough when you try to pour a glass of water. You do not know where to hold the glass or where to hold the pitcher. No matter how you hold them, the water will not pour—point the top of the pitcher toward the ceiling, or the floor, or the wall, it makes no difference. Finally you have to put your hand into the pitcher and pull the water out. It comes. Not a drop runs between your fingers—which way can it run, since there is no down? The big lump of water stays right on your hand. This surprises you so much that you let go of the pitcher. Never mind; the pitcher stays poised in mid-air. But how are you going to get a drink? It does not seem reasonable to try to drink a large *lump* of water. Yet when you hold the lump to your lips and suck it you can draw the water into your mouth, and it is as wet as ever; then you can force it on down to (or rather *toward*) your throat with your tongue. Still you have left in your hand a big piece of water that will not flow off. You throw it away, and it sails through the air of the cabin in a straight line until it splashes against the wall. It wets the wall as much as water on the earth would, but it does not run off. It sticks there, like a splash-shaped piece of clear, colorless gelatin.

Suppose that for the sake of experimenting you have brought an elephant along on this trip. You can move under him (or over him—anyway between him and the floor), brace your feet on the floor, and give him a push. (If he happens to step on your toes while you are doing this, you do not mind in the least, because he does not weigh anything, you know.) If you push hard enough to get the elephant started, he rises slowly toward the ceiling. When he objects on the way, and struggles and kicks and tries to get back to the floor, it does not help him at all. His bulky, kicking body floats steadily on till it crashes into the ceiling.

No chairs or beds are needed in this place. You can lie or sit in mid-air, or cling to a fixture on a wall, resting as gently there as a feather might. There is no need to set the table for meals—just lay the dishes with the food on them in space and they stay there. If the top of your cup of chocolate is toward the ceiling, and your plate of food is turned the other way, no harm is done. Your feet may happen to point toward the ceiling, while some one else's point toward the floor, as you sit in mid-air, eating. There is some difficulty in getting the food on the dishes, so probably you do not wish to bother with dishes, after all. Do you want some mashed potatoes? All right, here it is—and the cook jerks the spoon away from the potatoes, leaving them floating before you, ready to eat.

It is literally a topsy-turvy place.

Do you want to know why all this would happen? Here is the reason: There is a great force known as *gravitation*. It is the pull that everything in the universe has on everything else. The more massive a thing is, the more gravitational pull it has on other objects; but the farther apart things are, the less pull they have on each other.

The earth is very massive, and we live right on its surface; so it pulls us strongly toward it. Therefore we say that we weigh something. And since every time we roll off a bed, for instance, or jump off a chair, the earth pulls us swiftly toward it, we say that the earth is down. "Down" simply means toward the thing that is pulling us. If we were on the surface of the moon, the moon would pull us. "Down" would then be under our feet or toward the center of the moon, and the earth would be seen floating up in the sky. For "up" means *away from* the thing which is pulling us.

Why water does not flow off the earth. It was because people did not know about gravitation that they laughed at Columbus when he said the earth was round. "Why, if the earth were round," they argued, "the water would all flow off on the other side." They did not know that water flows downhill because the earth is pulling it toward its center by gravitation, and that it does not make the slightest difference on which side of the earth water is, since it is still pulled toward the center.

Why the world does not fall down. And people used to wonder "what held the earth up." The answer, as you can see, is easy. There simply is no up or down in space. The earth cannot fall down, because there is no down to fall to. "Down" merely means toward the earth, and the earth cannot very well fall toward itself, can it? The sun is pulling on it, though; so the earth could fall into the sun, and it would do so, if it were not swinging around the sun so fast. You will see how this keeps it from falling into the sun when you come to the section on centrifugal force.

Why there is a place where things weigh nothing. Now about the place where gravitation has no effect. Since an object near the sun is pulled more by the sun than it is by the earth, and since down here near the earth an object is pulled harder by the earth than by the sun, it is clear that there must be a place between the sun and the earth where their pulls just balance; and where the sun pulls just as hard one way as the earth pulls the other way, things will not fall either way, but will float. The place where the pulls of the sun and the earth are equal is not halfway between the earth and the sun, because the sun is so much larger and pulls so much more powerfully than the earth, that the place where their pulls balance is much nearer the earth than it is to the sun. As a matter of fact, it can be easily calculated that this spot is somewhere

near 160,000 miles from the earth.

There are other spots like it between every two stars, and in the center of the earth, and in the center of every other body. You see, in the center of the earth there is just as much of the earth pulling one way as there is pulling the other, so again there is no up or down.

Application 1. Explain why the people on the other side of the earth do not fall off; why you have weight; why rivers run downhill; why the world does not fall down.

[pg 6]

SECTION 2. "*Water seeks its own level.*"

Why does a spring bubble up from the ground?
What makes the water come up through the pipe into your house?
Why is a fire engine needed to pump water up high?

You remember that up where the pull of the earth and the sun balance each other, water could not flow or flatten out. Let us try to imagine that water, here on the earth, has lost its habit of flattening out whenever possible—that, like clay, it keeps whatever shape it is given.

First you notice that the water fails to run out of the faucets. (For in most places in the world as it really is, the water that comes through faucets is simply flowing down from some high reservoir.) People all begin to search for water to drink. They rush to the rivers and begin to dig the water out of them. It looks queer to see a hole left in the water wherever a person has scooped up a pailful. If some one slips into the river while getting water, he does not drown, because the water cannot close in over his head; there is just a deep hole where he has fallen through, and he breathes the air that comes down to him at the bottom of the hole. If you try to row on the water, each stroke of the oars piles up the water, and the boat makes a deep furrow wherever it goes so that the whole river begins to look like a rough, plowed field.

[pg 7]

When the rivers are used up, people search in vain for springs. (No springs could flow in our everyday world if water did not seek its own level; for the waters of the springs come from hills or mountains, and the higher water, in trying to flatten out, forces the lower water up through the ground on the hillsides or in the valleys.) So people have to get their water from underground or go to lakes for it. And these lakes are strange sights. Storms toss up huge waves, which remain as ridges and furrows until another storm tears them down and throws up new ones.

But with no rivers flowing into them, the lakes also are used up in time. The only fresh water to be had is what is caught from the rain. Even wells soon become useless; because as soon as you pump up the water surrounding the pump, no more water flows in around it; and if you use a bucket to raise the water, the well goes dry as soon as the supply of water standing in it has been drawn.

You will understand more about water seeking its own level if you do this experiment:

Experiment 1. Put one end of a rubber tube over the narrow neck of a funnel (a glass funnel is best), and put the other end of the tube over a piece of glass tubing not less than 5 or 6 inches long. Hold up the glass tube and the funnel, letting the rubber tube sag down between them as in Figure 1. Now fill the funnel three fourths full of water. Raise the glass tube higher if the water starts to flow out of it. If no water shows in the glass tube, lower it until it does. Gradually raise and lower the tube, and notice how high the water goes in it whenever it is held still.

This same thing would happen with any shape of tube or funnel. You have another example of it when you fill a teakettle: the water rises in the spout just as high as it does in the kettle.

[pg 8]

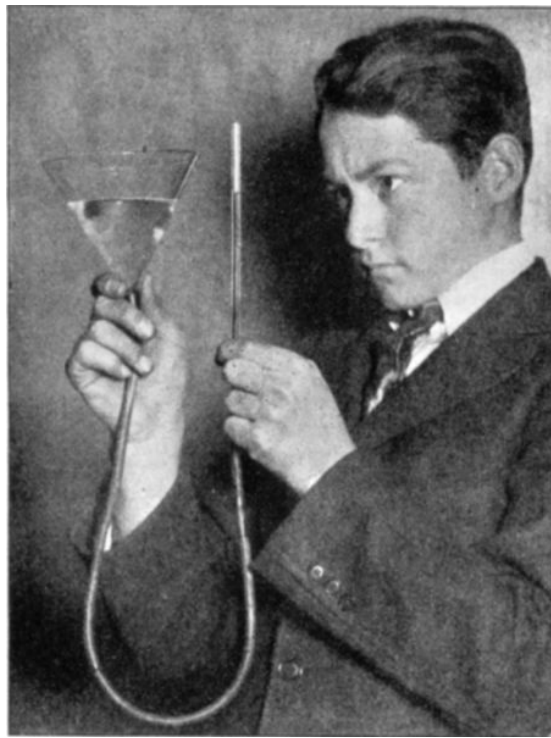

FIG. 1. The water in the tube rises to the level of the water in the funnel.

Why water flows up into your house. It is because water seeks its own level that it comes up through the pipes in your house. Usually the water for a city is pumped into a reservoir that is as high as the highest house in the city. When it flows down from the reservoir, it tends to rise in any pipe through which it flows, to the height at which the water in the reservoir stands. If a house is higher than the surface of the water in the reservoir, of course that house will get no running water.

[pg 9]

Why fire engines are needed to force water high. In putting out a fire, the firemen often want to throw the water with a good deal of force. The tendency of the water to seek its own level does not always give a high enough or powerful enough stream from the fire hose; so a fire engine is used to pump the water through the hose, and the stream flows with much more force than if it were not pumped.

Application 2. A. C. Wheeler of Chicago bought a little farm in Indiana, and had a windmill put up to supply the place with water. But at first he was not sure where he should put the tank into which the windmill was to pump the water and from which the water should flow into the kitchen, bathroom, and barn. The barn was on a knoll, so that its floor was almost as high as the roof of the house. Which would have been the best place for the tank: high up on the windmill (which stood on the knoll by the barn), or the basement of the house, or the attic of the house?



FIG. 2. Where is the best location for the tank?

Application 3. A man was about to open a garage in San Francisco. He had a large oil tank and wanted a simple way of telling at a glance how full it was. One of his workmen suggested that he attach a long piece of glass tubing to the side of the tank, connecting it with an extra faucet near the bottom of the tank. A second workman said, "No, that

[pg 10]

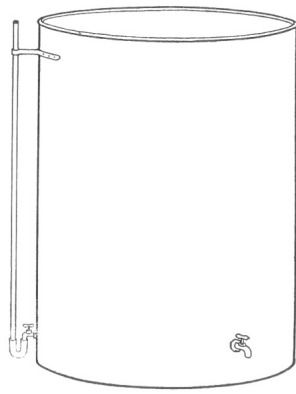

won't do. Your tank holds ever so much more than the tube would hold, so the oil in the tank would force the oil up over the top of the tube, even when the tank was not full." Who was right?

FIG. 3. When the tank is full, will the oil overflow the top of the tube?

SECTION 3. *The sea of compressed air in which we live: Air pressure.*

Does a balloon explode if it goes high in the air?

What is suction?

Why does soda water run up a straw when you draw on the straw?

Why will evaporated milk not flow freely out of a can in which there is only one hole?

Why does water gurgle when you pour it out of a bottle?

We are living in a sea of compressed air. Every square inch of our bodies has about 15 pounds of pressure against it. The only reason we are not crushed is that there is as strong pressure inside of our bodies pushing out as there is outside pushing in. There is compressed air in the blood and all through the body. If you were to lie down on the ground and have all the air pumped out from under you, the air above would crush you as flat as a pancake. You might as well let a dozen big farm horses trample on you, or let a huge elephant roll over you, as let the air press down on you if there were no air underneath and inside your body to resist the pressure from above. It is hard to believe that the air and liquids in our bodies are pressing out with a force great enough to resist this crushing weight of air. But if you were suddenly to go up above the earth's atmosphere, or if you were to stay down here and go into a room from which the air were to be pumped all at once, your body would explode like a torpedo.

[pg 11]

When you suck the air out of a bottle, the surrounding air pressure forces the bottle against your tongue; if the bottle is a small one, it will stick there. And the pressure of the air and blood in your tongue will force your tongue down into the neck of the bottle from which part of the air has been taken.

In the same way, when you force the air out of a rubber suction cap, such as is used to fasten reading lamps to the head of a bed, the air pressure outside holds the suction cap tightly to the object against which you first pressed it, making it stick there.

We can easily experiment with air pressure because we can get almost entirely rid of it in places and can then watch what happens. A place from which the air is practically all pumped out is called a *vacuum*. Here are some interesting experiments that will show what air pressure does:

[pg 12]



FIG. 4. When the point is knocked off the electric lamp, the water is forced into the vacuum.

Experiment 2. Hold a burned-out electric lamp in a basin of water, break its point off, and see what happens.

All the common electric lamps (less than 70 watts) are made with vacuums inside. The reason for this is that the fine wire would burn up if there were any air in the lamps. When you knock the point off the globe, it leaves a space into which the water can be pushed. Since the air is pressing hard on the surface of the water except in the one place where the vacuum in the lamp globe is, the water is forced violently into this empty space.

[pg 13]

It really is a good deal like the way mud comes up between your toes when you are barefoot. Your foot is pressing on the mud all around except in the spaces between your toes, and so the mud is forced up into these spaces. The air pressure on the water is like your foot on the mud, and the space in the lamp globe is like the space between your toes. Since wherever there is air it is pressing hard, the only space into which it can force water or anything else is into a place from which all the air has been removed, like the inside of the lamp globe.

The reason that the water does not run out of the globe is this: the hole is too small to let the air squeeze up past the water, and therefore no air can take the place of the water that might otherwise run out. In order to flow out, then, the water would have to leave an empty space or vacuum behind it, and the air pressure would not allow this.

Why water gurgles when it pours out of a bottle. You have often noticed that when you pour water out of a bottle it gurgles and gulps instead of flowing out evenly. The reason for this is that when a little water gets out and leaves an empty space behind, the air pushing against the water starts to force it back up; but since the mouth of the bottle is fairly wide, the air itself squeezes past the water and bubbles up to the top.

Experiment 3. Put a straw or a piece of glass tube down into a glass of water. Hold your finger tightly over the upper end, and lift the tube out of the water. Notice how the water stays in the tube. Now remove your finger from the upper end.

[pg 14]

The air holds the water up in the tube because there is no room for it to bubble up into the tube to take the place of the water; and the water, to flow out of the tube, would have to leave a vacuum, which the air outside does not allow. But when you take your finger off the top of the straw or tube, the air from above takes the place of the water as rapidly as it flows out; so there is no tendency to form a vacuum, and the water leaves the tube. Now do you see why you make two holes in the top of a can of evaporated milk when you wish to pour the milk out evenly?



FIG. 5. The water is held in the tube by air pressure.

Experiment 4. Push a rubber suction cap firmly against the inside of the bell jar of an air pump. Try to pull the suction cap off. If it comes off, press it on again; place the bell jar on the plate of the air pump, and pump the air out of the jar. What must have been holding the suction cap against the inside of the jar? Does air press up and sidewise as well as down? Test this further in the following experiment:

[pg 15]

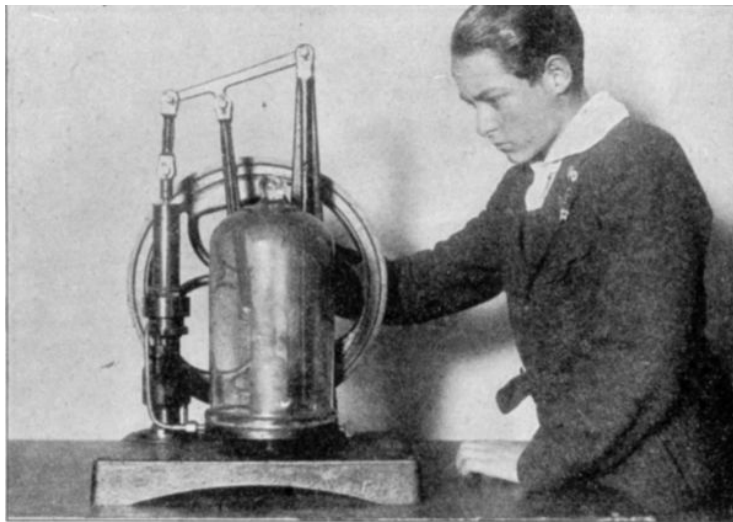

FIG. 6. An air pump.

Experiment 5. Put a cork into an empty bottle. Do not use a new cork, but one that has been fitted into the bottle many times and has become shaped to the neck. Press the cork in rather firmly, so that it is air-tight, but do not jam it in. Set the bottle on the plate of the air pump, put the bell jar over it, and pump the air out of the jar. What makes the cork fly out of the bottle? What was really in the "empty" bottle? Why could it not push the cork out until you had pumped the air out of the jar?

Experiment 6. Wax the rims of the two Magdeburg hemispheres (see Fig. 7). Screw the lower section into the hole in the plate of the air pump. Be sure that the stop valve in the neck of the hemisphere is open. (The little handle should be vertical.) Fit the other section on to the first, and pump out as much air as you can. *Close* the stop valve. Unscrew the hemispheres from the air pump. Try to pull them apart—pull straight out, taking care not to slide the parts. If you wish, let some one else take one handle, and see if the two of you can pull it apart.

[pg 16]

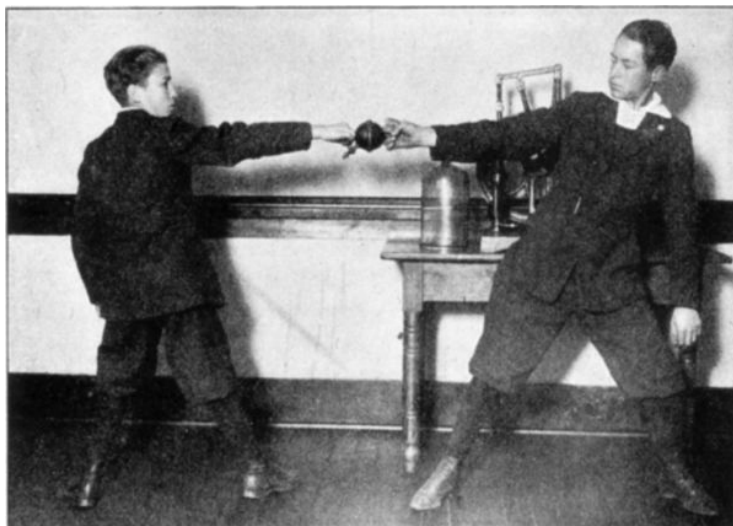

FIG. 7. The experiment with the Magdeburg hemispheres.

Before you pumped the air out of the hemisphere, the compressed air inside of them (you remember all the air down here is compressed) was pushing them apart just as hard as the air outside of them was pushing them together. When you pumped the air out, however, there was hardly any air left inside of them to push outward. So the strong pressure of the outside air against the hemispheres had nothing to oppose it. It therefore pressed them very tightly together and held them that way.

This experiment was first tried by a man living in Magdeburg, Germany. The first set of hemispheres he used proved too weak, and when the air in them was partly pumped out, the pressure of the outside air crushed them like an egg shell. The second set was over a foot in diameter and much stronger. After he had pumped the air out, it took sixteen horses, eight pulling one way and eight the opposite way, to pull the hemispheres apart.

[pg 17]

Experiment 7. Fill a bottle (or flask) half full of water. Through a one-hole stopper that will fit the bottle, put a bent piece of glass tubing that will reach down to the bottom of the bottle. Set the bottle, thus stoppered, on the plate of the air pump, with a beaker or tumbler under the outer end of the glass tube. Put the bell jar over the bottle and glass, and pump the air out of the jar. What is it that forces the water up and out of the bottle? Why could it do this when the air was pumped out of the bell jar and not before?

How a seltzer siphon works. A seltzer siphon works on the same principle. But instead of the ordinary compressed air that is all around us, there is in the seltzer siphon a gas (carbon dioxide) which has been much more compressed than ordinary air. This strongly compressed gas forces the seltzer water out into the less compressed air, exactly as the compressed air in the upper part of the bottle forced the water out into the comparative vacuum of the bell jar in Experiment 7.

Experiment 8. Fill a toy balloon partly full of air by blowing into it, and close the neck with a rubber band so that no air can escape. Lay a saucer over the hole in the plate of the air pump, so that the rubber of the balloon cannot be sucked down the hole. Lay the balloon on top of this saucer, put the bell jar over it, and pump the air out of the jar. What makes the balloon expand? What is in it? Why could it not expand before you pumped the air out from around it?

A toy balloon expands for the same reason when it goes high in the air. Up there the air pressure is not so strong outside the balloon, and so the gas inside makes the balloon expand until it bursts.

[pg 18]



FIG. 8. A siphon. The air pushes the water over the side of the pan.

Experiment 9. Lay a rubber tube flat in the bottom of a pan of water, so that the tube will be filled with water. Let one end stay under water, but pinch the other end tightly shut with your thumb and finger and lift it out of the pan. Lower this closed end into a pan or empty pan that is lower than the pan of water. Now stop pinching the tube shut. This device is called a *siphon* (Fig. 8).

Experiment 10. Put the mouth of a small syringe, or better, of a glass model lift pump, under water. Draw the handle up. Does the water follow the plunger up, stand still, or go down in the pump?

When you pull up the plunger, you leave an empty space; you shove the air out of the pump or syringe ahead of the plunger. The air outside, pressing on the water, forces it up into this empty space from which the air has been pushed. But air pressure cannot force water up even into a perfect vacuum farther than about 33 feet. If your glass pump were, say, 40 feet long, the water would follow the plunger up for a little over 30 feet, but nothing could suck it higher; for by the time it reaches that height it is pushing down with its own weight as hard as the air is pressing on the water below. No suction pump, or siphon, however perfect, will ever lift water more than about 33 feet, and it will do well if it draws water up 28 or 30 feet. This is because a perfect vacuum cannot be made. There is always some water vapor formed by the water evaporating a little, and there is always a small amount of air that has been dissolved in water, both of which partly fill the space above the water and press down a little on the water within the pump.

[pg 19]

[pg 20]

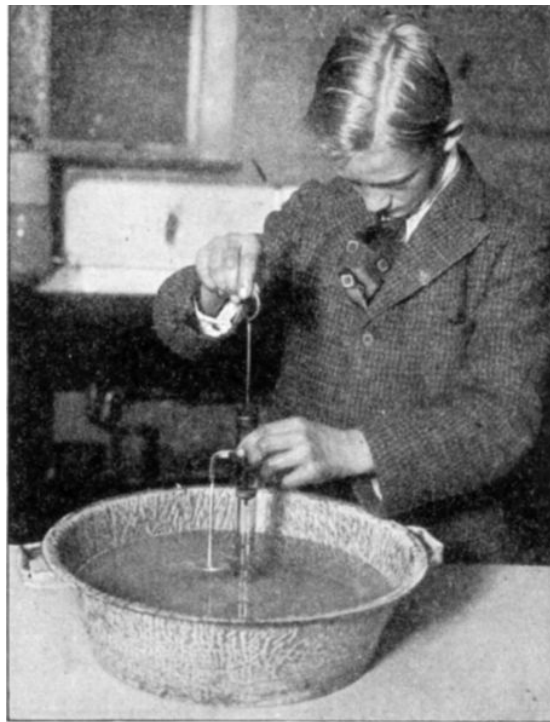

FIG. 9. A glass model suction pump.

If you had a straw over 33 feet long, and if some one held a glass of lemonade for you down near the sidewalk while you leaned over from the roof of a three-story building with your long straw, you could not possibly drink the lemonade. The air pressure would not be great enough to lift it so high, no matter how hard you sucked,—that is, no matter how perfect a vacuum you made in the upper part of the straw. The lemonade would rise part way, and then your straw would be flattened by the pressure outside.

Some days the air can force water up farther in a tube than it can on other days. If it can force the water up 33 feet today, it will perhaps be able to force it up only 30 feet immediately before a storm. And if it forces water up 33 feet at sea level, it may force it up only 15 or 20 feet on a high mountain, for on a mountain there is much less air above to make pressure. The pressure of the air is different in different places; where the air is heavy and pressing hard, we say the pressure is *high*; where the air is light and not pressing so hard, we call the pressure *low*. A place where the air is heavy is called an area of high pressure; where it is light, an area of low pressure. (See Section 44.)

[pg 21]

What makes winds? It is because the air does not press equally all the time and everywhere that we have winds. Naturally, if the air is pressing harder in one place than in another, the lower air will be pushed sidewise in the areas of high pressure and will rush to the areas where there is less pressure. And air rushing from one place to another is called *wind*.

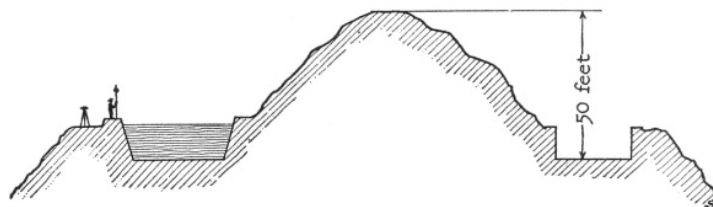

FIG. 10.

Application 4. A man had two water reservoirs, which stood at the same level, one on each side of a hill. The hill between them was about 50 feet high. One reservoir was full, and the other was empty. He wanted to get some of the water from the full reservoir into the empty one. He did not have a pump to force the water from one to the other, but he did have a long hose, and could have bought more. His hose was long enough to reach over the top of the hill, but not long enough to go around it. Could he have siphoned the water from one reservoir to the other? Would he have had to buy more hose?

Application 5. Two boys were out hiking and were very thirsty. They came to a deserted farm and found a deep well; it was about 40 feet down to the water. They had no pump, but there was a piece of hose about 50 feet long. One boy suggested that they

drop one end of the hose down to the water and suck the water up, but the other said that that would not work—the only way would be to lower the hose into the water, close the upper end, pull the hose out and let the water pour out of the lower end of the hose into their mouths. A stranger came past while the boys were arguing, and said that neither way would work; that although the hose was long enough, the water was too far down to be raised in either way. He advised the boys to find a bucket and to use the hose as a rope for lowering it. Who was right?

Inference Exercise

EXPLANATORY NOTE. In the inference exercises in this book, there is a group of facts for you to explain. They can always be explained by one or more of the principles studied, like gravitation, water seeking its own level, or air pressure. If asked to explain why sucking through a straw makes soda water come up into your mouth, for instance, you should not merely say "air pressure," but should tell why you think it is air pressure that causes the liquid to rise through the straw. The answer should be something like this: "The soda water comes up into your mouth because the sucking takes the air pressure away from the top of the soda water that is in the straw. This leaves the air pressing down only on the surface of the soda water in the glass. Therefore, the air pressure pushes the soda water up into the straw and into your mouth where the pressure has been removed by sucking." Sometimes, when you have shown that you understand the principles very well, the teacher may let you take a short cut and just name the principle, but this will be done only after you have proved by a number of full answers that you thoroughly understand each principle named.

Some of the following facts are accounted for by air pressure; some by water seeking its own level; others by gravitation. See if you can tell which of the three principles explains each fact:

1. Rain falls from the clouds.
2. After rain has soaked into the sides of mountains it runs underground and rises, at lower levels, in springs.
3. When there are no springs near, people raise the water from underground with suction pumps.
4. As fast as the water is pumped away from around the bottom of a pump, more water flows in to replace it.
5. After you pump water up, it flows down into your pail from the spout of the pump.
6. You can drink lemonade through a straw.
7. If a lemon seed sticks to the bottom of your straw, the straw flattens out when you suck.
8. When you pull your straw out to remove the seed, there is no hole left in the lemonade; it closes right in after the straw.
9. If you drop the seed, it falls to the floor.
10. If you tip the glass to drink the lemonade, the surface of the lemonade does not tip with the glass, but remains horizontal.

SECTION 4. *Sinking and floating: Displacement.*

What keeps a balloon up?

What makes an iceberg float?

Why does cork float on the water and why do heavier substances sink?

If iron sinks, why do iron ships not sink?

Again let us imagine ourselves up in the place where gravitation has no effect. Suppose we lay a nail on the surface of a bowl of water. It stays there and does not sink. This does not seem at all surprising, of course, since the nail no longer has weight. But when we put a cork in the midst of the water, it stays there instead of floating to the surface. This seems peculiar, because the less a thing weighs the more easily it floats. So when the cork weighs nothing at all, it seems that it should float better than ever. Of course there is some difficulty in deciding whether it ought to float toward the part of the water nearest the floor or toward the part nearest the ceiling, since there is no up or down; but one would think that it ought somehow to get to the outside of the water and not stay exactly in the middle. If put on the outside, however, it stays there as well.

A toy balloon, in the same way, will not go toward either the ceiling or the floor, but just stays where it is put, no matter how light a gas it is filled with.

The explanation is as follows: For an object to float on the water or in the air, the water or air must be heavier than the object. It is the water or air being pulled under the object by gravity, that pushes it up. Therefore, if the air and water themselves weighed nothing, of course they would be no heavier than the balloon or the cork; the air or water would then not be pulled in under the balloon or cork by gravity, and so would not push them up, or aside.

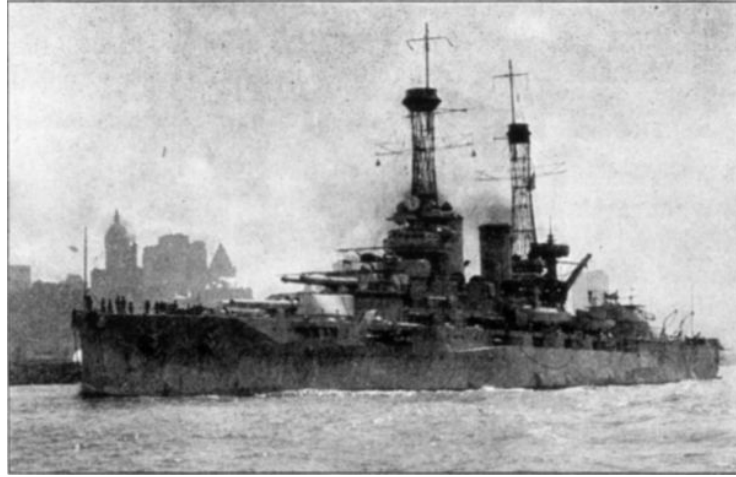

FIG. 11. The battleship is made of steel, yet it does not sink.

Why iron ships float. When people first talked about building iron ships, others laughed at them. "Iron sinks," they said, "and your boats will go to the bottom of the sea." If the boats were solid iron this would be true, for iron is certainly much heavier than water. But if the iron is bent up at the edges,—as it is in a dish pan,—it has to push much more water aside before it goes under than it would if it were flattened out. The water displaced, or pushed aside, would have to take up as much room as was taken up by the pan *and all the empty space inside of it*, before the edge would go under. Naturally this amount of water would weigh a great deal more than the empty pan.

But suppose you should fill the dish pan with water, or suppose it leaked full. Then you would have the weight of all the water in it added to the weight of the pan, and that would be heavy enough to push aside the water in which it was floating and let the pan sink. This is why a ship sometimes sinks when it springs a leak.

You may be able to see more clearly why an iron ship floats by this example: Suppose your iron ship weighs 6000 tons and that the cargo and crew weigh another 1000 tons. The whole thing, then, weighs 7000 tons. Now that ship is a big, bulky affair and takes up more space than 7000 tons of water does. As it settles into the water it pushes a great deal of water out of the way, and after it sinks a certain distance it has pushed 7000 tons of water out of the way. Since the ship weighs only 7000 tons, it evidently cannot push aside more than that weight of water; so part of the ship stays above the water, and all there is left for it to do is to float. If the ship should freeze solid in the water where it floated and then could be lifted out of the ice by a huge derrick, you would find that you could pour exactly 7000 tons of water into the hole where the ship had been.

But if you built your ship with so little air space in it that it took less room than 7000 tons of water takes, it could go clear under the water without pushing 7000 tons of water aside. Therefore a ship of this kind would sink.

The earth's gravity is pulling on the ship and on the water. If the ship has displaced (pushed aside) its own weight of water, gravity is pulling down on the water as hard as it is on the ship; so the ship cannot push any more water aside, and if there is enough air space in it, the ship floats.

Perhaps the easiest way to say it is like this: Anything that is lighter than the same volume of water will float; since a cubic foot of wood weighs less than a cubic foot of water, the wood will float; since a quart of oil is lighter than a quart of water, the oil will float; since a pint of cream is lighter than a pint of milk, the cream will rise. In the same way, anything that is lighter than the same volume of air will be pushed up by the air. When a balloon with its passengers weighs less than the amount of air that it takes the place of at any one time, it will go up. Since a quart of warm air weighs less than a quart of cold air, the warm air will rise.

You can see how a heavy substance like water pushes a lighter one, like oil, up out of its way, in the following experiment:

Experiment 11. Fill one test tube to the brim with kerosene slightly colored with a little iodine. Fill another test tube to the brim with water, colored with a little blueing. Put a small square of cardboard over the test tube of water, hold it in place, and turn the test tube upside down. You can let go of the cardboard now, as the air pressure will hold it up. Put the mouth of the test tube of water exactly over the mouth of the test

tube of kerosene. Pull the cardboard out from between the two tubes, or have some one else do this while you hold the two tubes mouth to mouth. If you are careful, you will not spill a drop. If nothing happens when the cardboard is pulled away, gently rock the two tubes, holding their mouths tightly together.



FIG. 12. The upper tube is filled with water and the lower with oil. What will happen when she pulls the cardboard out?

Oil is lighter than water, as you know, because you have seen a film of oil floating on water. When you have the two test tubes in such a position that the oil and water can change, the water is pulled down under the kerosene because gravity is pulling harder on the water than it is pulling on the kerosene. The water, therefore, goes to the bottom and this forces the kerosene up.

Application 6. Three men were making a raft. For floats they meant to use some air-tight galvanized iron cylinders. One of them wanted to fill the cylinders with cork, "because," he said, "cork is what you put in life preservers and it floats better than anything I know of." "They'd be better with nothing in them at all," said a second. "Pump all the air out and leave vacuums. They're air-tight and they are strong enough to resist the air pressure." But the third man said, "Why, you've got to have some air in them to buoy them up. Cork would be all right, but it isn't as light as air; so air would be the best thing to fill them with."

Which way would the floats have worked best?

Application 7. A little girl was telling her class about icebergs. "They are very dangerous," she said, "and ships are often wrecked by running into them. You see, the sun melts the top off them so that all there is left is under water. The sailors can't see the ice under water, and so their ships run into it and are sunk." Another girl objected to this; she said, "That couldn't be; the ice would bob up as fast as the top melted." "No, it wouldn't," said a boy. "If that lower part wasn't heavier than water, it never would have stayed under at all. And if it was heavier at the beginning, it would still be heavier after the top melted off."

Who was right?

Inference Exercise

Explain the following:

11. When you wash dishes, a cup often floats on top of the water, while a plate made of the same sort of china sinks to the bottom of the pan.
12. If you put the cup in sidewise, it sinks.
13. The water in the cup, when lying on its side, is exactly as high as the water in the dish pan.
14. If you put a glass into the water, mouth first, the water cannot get up into the glass; if you tip it a little, there are bubbles in the water and some water enters the glass.
15. If you let a dish slip while you are wiping it, it crashes to the floor.
16. It is much harder to hold a large platter while you are wiping it than it is to hold a small butter plate.
17. If you set a hot glass upside down on the oilcloth table cover, the oilcloth bulges up

into it when the hot air and steam shrink and leave a partial vacuum within the glass.

18. If you spill any of the dishwater on the floor, it flattens out.

[pg 29]

19. You may use a kind of soap that is full of invisible little air bubbles; if you do, the soap will float on top of the water.

20. When you drop a dry dishcloth into water, it floats until all the pores are filled with water; then it sinks.

SECTION 5. *How things are kept from toppling over: Stability.*

Why is it harder to keep your balance on stilts than on your feet?

Why does a rowboat tip over more easily if you stand up in it?

In Pisa, Italy, there is a beautiful marble bell tower which leans over as if it were just about to fall to the ground. Yet it has stood in this position for hundreds of years and has never given a sign of toppling. The foundations on which it rested sank down into the ground on one side while the tower was being built (it took over 200 years to build it), and this made it tip. But the men who were building it evidently felt sure that it would not fall over in spite of its tipping. They knew the law of stability.

[pg 30]

All architects and engineers and builders have to take this law into consideration or the structures they put up would topple over. And your body learned the law when you were a little over a year old, or you never could have walked. It is worth while for your brain to know it, too, because it is a very practical law that you can use in your everyday life.

If you wish to understand why the Leaning Tower of Pisa does not fall over, why it is hard to walk on stilts, why a boat tips when a person stands up in it, why blocks fall when you build too high with them, and how to keep things from tipping over, do the following experiment and read the explanation that follows it:

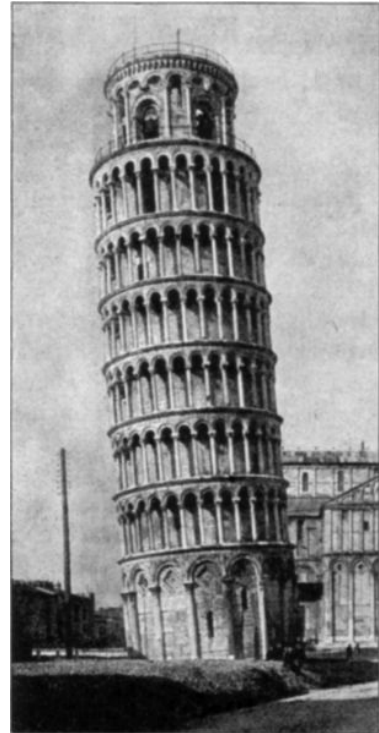

FIG. 13. The Leaning Tower of Pisa.

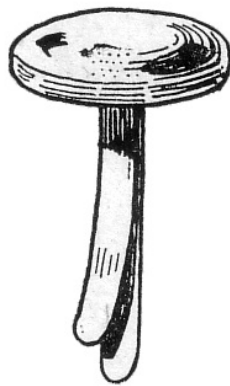

FIG. 14.

Experiment 12.² Unscrew the bell from a doorbell or a telephone. You will not harm it at all, and you can put it back after the experiment. Cut a sheet of heavy wrapping paper or light-weight cardboard about 5 × 9 inches. Roll this so as to make a cylinder about 5 inches high and as big around as the bell. Hold it in shape by pasting it or putting a couple of rubber bands around it. Cut two strips of paper about an inch wide and 8 inches long; lay these crosswise; lay the bell, round side down, on the center of the cross. Push a paper fastener through the hole in the bell (the kind shown in Figure 14) and through the crossed pieces of paper, spreading the fastener out so as to fasten the paper cross to the rounded side of the bell. Bend the arms of the cross up around the bell and paste them to the sides of the paper cylinder so that the bell makes a curved bottom to the cylinder, as shown in Figure 15.

Footnote 2: TO THE TEACHER. If you have a laboratory, it is well to have this cylinder already made for the use of all classes.

[pg 31]

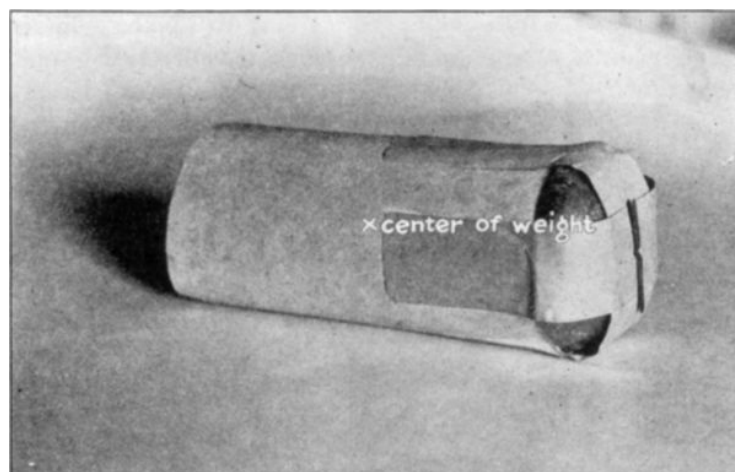

FIG. 15. In this cylinder the center of weight is so high that it is not over the bottom if the cylinder is tipped to any extent. So the cylinder falls over easily and lies quietly on its side.

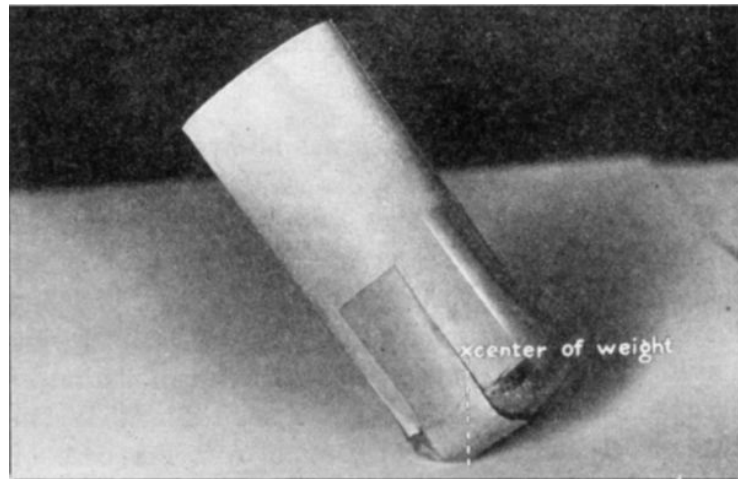

FIG. 16. But in this one the center of weight is so low that it is over the base, no matter what position the cylinder is in.

[pg 32]



Try to tip the cylinder over. Now stuff some crumpled paper loosely into the cylinder, filling it to the top. Tip the cylinder again. Will it stay on its side now? Force all the crumpled paper to the bottom of the cylinder. Now will it stay on its side? Take out the crumpled paper and lay a flat stone in the bottom of the bell, holding it in place by stuffing some crumpled paper in on top of it. Will the cylinder tip over now? Take the stone out, put the crumpled paper in the bottom of the cylinder, put the stone on top of the paper, and again try to tip the cylinder over. Will it fall?

FIG. 17. So even if the cylinder is laid on its side it immediately comes to an upright position again.

The center of the cylinder was always in one place, of course. But the *center of the weight* in that cylinder was usually near the bottom, because the bell weighed so much more than the paper. When you raised the center of weight by putting the stone up high or filling the cylinder with crumpled paper, just a little tipping moved the center of weight so that it was not directly over the bell on which the cylinder was resting. Whenever the center of weight is not over the base of support (the bottom on which the thing is standing), an object will topple over. Moving the center of weight up (Figs. 15 and 16) makes an object less stable.

[pg 33]

The two main points to remember about stability are these: the wider the base of an object, the harder it is to tip over; and the lower the center of the weight is, the harder it is to tip over.

If you were out in a rowboat in a storm, would it be better to sit up straight in the seat or to lie in the bottom of the boat?

Why is a flat-bottomed boat safer than a canoe?



FIG. 18. Which vase would be the hardest to upset?

[pg 34]

Where do you suppose the center of weight of the Leaning Tower of Pisa is,—near the bottom or near the top?

Application 8. If you had a large flower to put into a vase and you did not want it to tip over easily, which of the three vases shown in Figure 18 would you choose?

Application 9. Some boys made themselves a little sail-boat and went sailing in it. A storm came up. The boat rocked badly and was in danger of tipping over. "Throw out all the heavy things, quick!" shouted one. "No, no, don't for the life of you do it!" called another. "Chop down the mast—here, give me the hatchet!" another one said. "Crouch way down—lie on the bottom." "No, keep moving over to the side that is tipped up!" "Hold the things in the bottom of the boat still, so they'll not keep rolling from side to side." "Jump out and swim!" Every one was shouting at once. Which parts of the advice should you have followed if you had been on board?

Inference Exercise

Explain the following:

21. A ship when it goes to sea always carries ballast (weight) in its bottom.
22. If the ship springs a leak below the water line, the water rushes in.
23. The ship's pumps suck the water up out of the bottom of the ship.
24. The water pours back into the sea from the mouths of the pumps.
25. As the sailors move back and forth on the ship during a storm, they walk with their legs spread far apart.
26. Although the ship tips far from side to side, it rights itself.
27. However far the ship tips, the surface of the water in the bottom stays almost horizontal.
28. While the ship is in danger, the people put on life preservers, which are filled with cork.
29. When the ship rocks violently, people who are standing up are thrown to the floor, but those who are sitting down do not fall over.
30. If the ship fills with water faster than the engines can pump it out, the ship sinks.

[pg 35]

[pg 36]

CHAPTER TWO

MOLECULAR ATTRACTION

SECTION 6. *How liquids are absorbed: Capillary attraction.*

Why do blotters pull water into themselves when a flat piece of glass will not?

How does a towel dry your face?

Suppose you could turn off nature's laws in the way that you can turn off electric lights. And suppose you stood in front of a switchboard with each switch labeled with the name of the law it would shut off. Of course, there is no such switchboard, but we know pretty well what would happen if we *could* shut off various laws. One of the least dangerous-looking switches would be one labeled CAPILLARY ATTRACTION. And now, just for fun, suppose that you have turned that switch off in order to see the effect.

At first you do not notice any change; but after a while you begin to feel perspiration collecting all over your body as if your clothes were made of rubber sheeting. Soon this becomes so uncomfortable that you decide to take a bath. But when you put your wash cloth into the water you find that it will not absorb any water at all; it gets a little wet on the outside, but remains stiff and is not easy or pleasant to use. You reach for a sponge or a bath brush, but you are no better off. Only the outside of the sponge and brush becomes wet, and they remain for the most part harsh and dry.

[pg 37]

Then perhaps you try to dry yourself with a towel. But that does not work; not a drop of water will the towel absorb. You might as well try to dry yourself on the glossy side of a piece of oilcloth.

By this time you are shivering; so you probably decide to light the oil stove and get warm and dry over that. But the oil will not come up the wick! As a last resort you throw a dressing gown around you (it does not get wet) and start a fire in the fireplace. This at last warms and dries you; but as soon as you are dressed the clammy feeling comes again—your clothes will not absorb any perspiration. While the capillary attraction switch is turned off you will simply have to get used to this.

Then suppose you start to write your experience. Your fountain pen will not work. Even an ordinary pen does not work as well as it ought to. It makes a blot on your paper. If you use the blotter you are dismayed to find that the blot spreads out as flat as if you were pressing a piece of glass against it. You take your eraser and try to remove the blot. To your delight you find that it rubs out as easily as a pencil mark. The ink has not soaked into the paper at all. You begin to see some of the advantages in shutting off capillary attraction.

Perhaps you are writing at the dining-room table, and you overturn the inkwell on the tablecloth. Never mind, it is no trouble to brush the ink off. Not a sign of stain is left behind.

[pg 38]

By and by you look outdoors at the garden. Everything is withering. The moisture does not move through the earth to where the roots of the plants can reach it. Before everything withers completely, you rush to the switchboard and turn on the capillary attraction again.

You can understand this force of capillary attraction better if you perform the following experiments:

Experiment 13. Fill a glass with water and color it with a little blueing or red ink. Into the glass put two or three glass tubes, open at both ends, and with bores of different sizes. (One of these tubes should be so-called thermometer tubing, with about 1 mm. bore.) Watch the colored water and see in which of the tubes it is pulled highest.

Experiment 14. Put a clean washed lamp wick into the glass of colored water and watch to see if the water is pulled up the wick. Now let the upper end of the wick hang over the side of the glass all night. Put an empty glass under the end that is hanging out. The next morning see what has happened.



FIG. 19. Will the water be drawn up higher in the fine glass tube or in a tube with a larger opening?

[pg 39]



FIG. 20. The water rises through the lamp wick by capillary attraction.

The space between the threads of the wick, and especially the still finer spaces between the fibers that make up the threads, act like fine tubes and the liquid rises in them just as it did in the fine glass tube. Wherever there are fine spaces between the particles of anything, as there are in a lump of sugar, a towel, a blotter, a wick, and hundreds of other things, these spaces act like fine tubes and the liquid goes into them. The force that causes the liquid to move along fine tubes or openings is called *capillary attraction*.

Capillary attraction—this tendency of liquids to go into fine tubes—is caused by the same force that makes things cling to each other (adhesion), and that makes things hold together (cohesion). The next two sections tell about these two forces; so you will understand the cause of capillary attraction more thoroughly after reading them. But you should know capillary attraction when you see it now, and know how to use it. The following questions will show whether or not you do:

[pg 40]

Application 10. Suppose you have spilled some milk on a carpet, and that you have at hand wet tea leaves, dry corn meal, some torn bits of a glossy magazine cover, and a piece of new cloth the pores of which are stopped up with starch. Which would be the best to use in taking up the milk?

Application 11. A boy spattered some candle grease on his coat. His aunt told him to lay a blotter on the candle grease and to press a hot iron on the blotter, or to put the blotter under his coat and the iron on top of the candle grease,—he was not quite sure which. While he was trying to recall his aunt's directions, his sister said that he could use soap and water to take the grease out; then his brother told him to scrape the spot with a knife. Which would have been the right thing for him to do?

Inference Exercise

Explain the following:

31. A pen has a slit running down to the point.
32. When a man smokes, the smoke goes from the cigar into his mouth.
33. A blotter which has one end in water soon becomes wet all over.
34. Cream comes to the top of milk.
35. It is much harder to stand on stilts than on your feet.
36. Oiled shoes are almost waterproof.
37. City water reservoirs are located on the highest possible places in or near cities.
38. You can fill a self-filling fountain pen by squeezing the bulb, then letting go.
39. The oceans do not flow off the world.
40. When you turn a bottle of water upside down the water gurgles out instead of coming out in a smooth, steady stream.

[pg 41]

SECTION 7. *How things stick to one another: Adhesion.*

Why is it that when a thing is broken it will not stay together without glue?

Why does chalk stay on the blackboard?

Now that you have found out something about capillary attraction, suppose that you should go to the imaginary switchboard again and tamper with some other law of nature. An innocent-looking switch, right above the capillary attraction switch, would be labeled ADHESION. Suppose you have turned it off:

In an instant the wall paper slips down from the walls and crumples to a heap on the floor. The paint and varnish drop from the woodwork like so much sand. Every cobweb and speck of dust rolls off and falls in a little black heap below.

When you try to wash, you cannot wet your hands. But they do not need washing, as the dirt tumbles off, leaving them cleaner than they ever were before. You can jump into a tank of water with all your clothes on and come out as dry as you went in. You discover by the dryness of your clothes that capillary attraction stopped when the adhesion was turned off, for capillary attraction is just a part of adhesion. But you are not troubled now with the clamminess of unabsorbed perspiration. The perspiration rolls off in little drops, not wetting anything but running to the ground like so much quicksilver.

[pg 42]

Your hair is fluffier than after the most vigorous shampoo. Your skin smarts with dryness. Your eyes are almost blinded by their lack of tears. Even when you cry, the tears roll from your eyeballs and eyelids like water from a duck's back. Your mouth is too dry to talk; all the saliva rolls down your throat, leaving your tongue and cheeks as dry as cornstarch.

I think you would soon turn on the adhesion switch again.

Experiment 15. Touch the surface of a glass of water, and then raise your finger slightly. Notice whether the water tends to follow or to keep away from your finger as you raise it. Now dip your whole finger into the water and draw it out. Notice how the water clings, and watch the drops form and fall off. Notice the film of water that stays on, wetting your finger, after all dropping stops.



FIG. 21. As the finger is raised the water is drawn up after it.

Which do you think is the stronger, the pull of gravity which makes some of the water drip off, or the pull of adhesion which makes some of the water cling to your finger?

If the pull of gravity is stronger, would not all the water drop off, leaving your finger dry? If the pull of adhesion is the stronger, would not all the water stay on your finger, none dropping off?

The truth of the matter is that gravity is stronger than adhesion unless things are very close together; then adhesion is stronger. The part of the water that is very close to your finger clings to it in spite of gravity; the part that is farther away forms drops and falls down because of the pull of gravity.

Adhesion, then, is the force that makes things cling to each other when they are very close together.

Why it is easier to turn a page if you wet your finger. Water spreads out on things so that it gets very close to them. The thin film of water on your finger is close enough to your finger and to the page which you are turning to cling to both; so when you move your finger, the page moves along with it.

Why dust clings to the ceiling and walls. The fine particles of dust are wafted up against the ceiling and walls by the moving air in the room. They are so small that they can fit into the small dents that are in plaster and paper and can get very close to the wall. Once they get close enough, the force of adhesion holds them with a pull stronger than that of gravity.

Oily and wet surfaces catch dust much more readily than clean, dry ones, simply because the dust can get so much closer to the oil or water film and because this film flows partly around each dust particle and holds it by the force of adhesion. This is why your face gets much dirtier when it is perspiring than when it is dry.

Application 12. Explain why cobwebs do not fall from the ceiling; why dust clings to a wet broom; why a postage stamp does not fall off an envelope.

Inference Exercise

Explain the following:

41. There are no springs on the tops of high mountains.
42. People used to shake sand over their letters after writing them in ink.
43. People used to make night lights for bedrooms by pouring some oil into a cup of water and floating a piece of wick on the oil. The oil always stayed on top of the water, and went up through the wick fast enough to keep the light burning.
44. Your face becomes much dirtier when you are perspiring.
45. Ink bottles are usually made with wide bases.
46. When you spill water on the floor, you cannot wipe it up with wrapping paper, but you can dry it easily with a cloth.
47. Oiled mops are used in taking up dust.
48. Cake will stick to a pan unless the pan is greased.
49. Although the earth turns completely over every day, we never fall off it.
50. Signs are fastened sometimes to windows or to the wind shields of automobiles by little rubber "suction caps."

SECTION 8. *The force that makes a thing hold together: Cohesion.*

What makes rain fall in drops?

Why are diamonds hard?

You have not yet touched any of the most dangerous switches on the imaginary switchboard of universal laws. But if your experience in turning off the capillary attraction and adhesion switches did not discourage you, you might try turning off the one beside them labeled COHESION:



FIG. 22. El Capitan, Yosemite Valley, California. If the force of cohesion were suspended, a mountain like this would immediately become the finest dust.

Things happen too swiftly for you to know much about them. The house you are in falls to dust instantly. You fall through the place where the floor has been; but you do not bump on the cement basement floor below, partly because there is no such thing as a hard floor or even hard ground anywhere, and partly because you disintegrate—fall to pieces—so completely that there is nothing left of you but a grayish film of fine dust and a haze of warm water.

[pg 46]

With a deafening roar, rocks, skyscrapers, and even mountains tumble down, fall to pieces, and sink into an inconceivably fine dust. Nothing stands up in the world—not a tree, not an animal, not an island. With a wild rush the oceans flood in over the dust that has been nations and continents, and then this dust turns to a fine muddy ooze in the bottom of a worldwide sea.

But it is an ocean utterly different from what we have in the real world. There are no waves. Neither are there any reflections of clouds in its surface,—first because the clouds would fly to pieces and turn to invisible vapor, and second, because the ocean has no surface—it simply melts away into the air and no one can tell where the water stops and where the air begins.

Then the earth grows larger and larger. The ocean turns to a heavy, dense, transparent steam. The fine mud that used to be rocks and mountains and living things turns to a heavy, dense gas.

Our once beautiful, solid, warm, living earth now whirls on through space, a swollen, gaseous globe, utterly dead.

And the only thing that prevents all this from actually happening right now is that there is a force called *cohesion* that holds things together. It is the pull which one particle of anything has on another particle of the same material. The paper in this book, the chair on which you are sitting, and you yourself are all made of a vast number of unthinkably small particles called *molecules*, each of which is pulling on its neighbor with such force that all stay in their places. Substances in which they pull the hardest, like steel, are very hard to break in two; that is, it is difficult to pull the molecules of these substances apart. In liquids, such as water, the molecules do not pull nearly so hard on each other. In a gas, such as air, they are so far apart that they have practically no pull on each other at all. That is why everything would turn to a gas if the force of cohesion stopped. Why things would turn cold will be explained in Chapter 4.

[pg 47]

Cohesion, adhesion, and capillary attraction, all are the result of the pull of molecules on each other. The difference is that capillary attraction is the pulling of particles of liquids up into fine spaces, as when a lamp wick draws up oil; adhesion is the pull of the particles of one substance or thing on the particles of another when they are very close together, as when water clings to your hand or when dust sticks to the ceiling; while cohesion is the clinging together of the particles of the same substance, like the holding together of the particles of your chair or of this paper.

When you put your hand into water it gets wet because the adhesion of the water to your hand is stronger than the cohesion of the water itself. The particles of the water are drawn to your hand more powerfully than they are drawn to each other. But in the following experiment, you have an example of cases where cohesion is stronger than adhesion:

Experiment 16. Pour some mercury (quicksilver) into a small dish and dip your finger into it. As you raise your finger, see if the mercury follows it up as the water did in Experiment 14. When you pull your finger all the way out, has the mercury wet it at all? Put a lamp wick or a part of your handkerchief into the mercury. Does it draw the mercury up as it would draw up water?

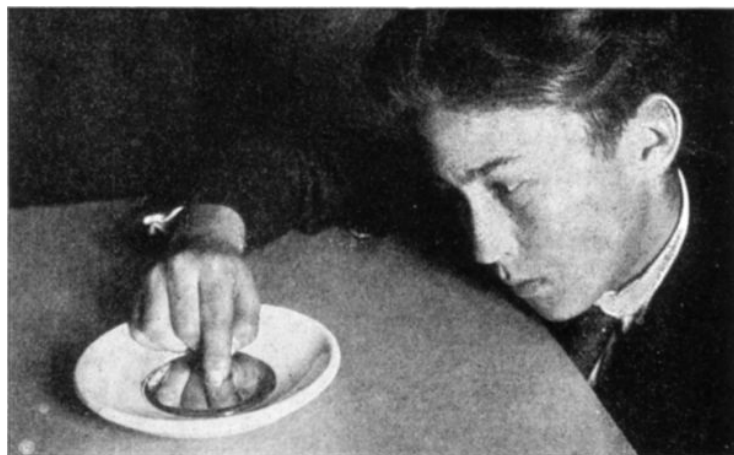

FIG. 23. The mercury does not wet the finger, and as the finger is lifted the mercury does not follow it.

The reason for this peculiarity of mercury is that the pull between the particles of mercury themselves is stronger than the pull between them and your finger or handkerchief. In scientific language, the cohesion of the mercury is stronger than its adhesion to your finger or handkerchief. Although this seems unusual for a liquid, it is what we naturally expect of solid things; you would be amazed if part of the wood of your school seat stuck to you when you got up, for you expect the particles in solid things to cohere—to have cohesion—much more strongly than they adhere to something else. It is because solids have such strong cohesion that they are solids.

Application 13. Explain why mercury cannot wet your fingers; why rain falls in *drops*; why it is harder to drive a nail into wood than into soap; why steel is hard.

Inference Exercise

Explain the following:

51. Ink spilled on a plain board soaks in, but on a varnished desk it can be easily wiped off.
52. When a window is soiled you can write on it with your finger; then your finger becomes soiled.
53. A starched apron or shirt stays clean longer than an unstarched one.
54. When you hold a lump of sugar with one edge just touching the surface of a cup of coffee, the coffee runs up the lump.
55. A drop of water on a dry plate is not flat but rounded.
56. It is hard to write on cloth because the ink spreads out and blurs.
57. If you roughen your finger nails by cleaning them with a knife, they will get soiled much more quickly than if you keep them smooth by using an orange stick.
58. When you dip your pen in the ink and then move it across the paper, it makes ink marks on the paper.
59. If you suck the air out of a bottle, the bottle will stick to your tongue.
60. You cannot break a thick piece of iron with your hands.

SECTION 9. *Friction.*

What makes ice slippery?

How does a brake stop a car?

Why do things wear out?

It would not be such a calamity if we were to turn off friction from the world. Still, I doubt whether we should want to leave it off much longer than was necessary for us to see what would happen. Suppose we imagine the world with all friction removed:

[pg 50]

A man on a bicycle can coast forever along level ground. Ships at sea can shut off steam and coast clear across the ocean. No machinery needs oiling. The clothes on your body feel smoother and softer than the finest silk. Perpetual motion is an established fact instead of an absolute impossibility; everything that is not going against gravity will keep right on moving forever or until it bumps into something else.

But, if there is no friction and you want to stop, you cannot. Suppose you are in an automobile when all friction stops. You speed along helplessly in the direction you are going. You cannot steer the machine—your hands would slip right around on the steering wheel, and even if you turn it by grasping the spoke, your machine still skids straight forward. If you start to go up a hill, you slow down, stop, and then before you can get out of the machine you start backward down the hill again and keep on going backward until you smash into something.

A person on foot does not fare much better. If he is walking at the time friction ceases, the ground is suddenly so slippery that he falls down and slides along on his back or stomach in the same direction he was walking, until he bumps into something big or starts to slip up a slope. If he reaches a slope, he, like the automobile, stops an instant a little way up, then starts sliding helplessly backward.

[pg 51]

Another man is standing still when the friction is turned off. He cannot get anywhere. As soon as he starts to walk forward, his feet slip out from under him and he falls on his face. He lies in the same spot no matter how he wriggles and squirms. If he tries to push with his hands, they slip over the rough ground more easily than they now slip through air. He cannot push sideways enough even to turn over. If there happens to be a rope within reach and one end is tied to a tree, he might try to take hold of the rope to pull himself along. But no matter how tightly he squeezes, the rope slips right through his hands when he starts to pull. If, however, there is a loop in the rope, he can slip his hand through the loop and try to pull. But the knots with which the rope is tied immediately come untied and he is as helpless as ever.

Even if he takes hold of a board fence he is no more successful. The nails in the board slip out of their holes and he is left with a perfectly slippery and useless board on the ground beside him for a companion. As it grows cold toward evening he may take some matches out of his pocket and try to start a fire. Aside from the difficulty of his being unable to hold them except by the most careful balancing or by shutting them up within his slippery hands, he is entirely incapable of lighting them; they slip over the cement beneath him or over the sole of his shoe without the least rubbing.

[pg 52]

In the real world, however, it is fortunately as impossible to get away from friction as it is to get away from the other laws we have tried to imagine as being turned off. There is always some friction, or rubbing, whenever anything moves. A bird rubs against the air, the point of a spinning top rubs against the sidewalk on which it is spinning. Your shoes rub against the ground as you walk and so make it possible for you to push yourself forward. The drive wheels of machinery rub against the belts and pull them along. There is friction between the wheels of a car and the track they are pushing against, or the wheels would whirl around and around uselessly.



FIG. 24. Hockey is a fast game because there is little friction between the skates and the ice.

But we can increase or decrease friction a great deal. If we make things rough, there is more friction between them than if they are smooth. If we press things tightly together, there is more friction than if they touch lightly. A nail in a loose hole comes out easily, but in a tight hole it sticks; the pressure has increased the friction. A motorman in starting a trolley car sometimes finds the track so smooth that the wheels whirl around without pushing the car forward; he pours

some sand on the track to make it rougher, and the car starts. When you put on new shoes, they are so smooth on the bottom that they slip over the ground because of the lack of friction. If you scratch the soles, they are rougher and you no longer slip. If you try to pull a stake out of the ground, you have to squeeze it harder than the ground does or it will slip out of your hands instead of slipping out of the ground. When you apply a brake to an automobile, the brake must press tightly against the axle or wheel to cause enough friction to stop the automobile.

There are always two results of friction: heat and wear. Sometimes these effects of friction are helpful to us, and sometimes they are quite the opposite. The heat from friction is helpful when it makes it possible for us to light a fire, but it is far from helpful when it causes a hot box because of an ungreased wheel on a train or wagon, or burns your hands when you slide down a rope. The wear from friction is helpful when it makes it possible to sandpaper a table, scour a pan, scrub a floor, or erase a pencil mark; but we don't like it when it wears out automobile tires, all the parts of machinery, and our clothes.

Experiment 17. Hold a nail against a grindstone while you turn the stone. Notice both the wear and heat. Let the nail rest lightly on the stone part of the time and press hard part of the time. Which way does the nail get hotter? Which way does it wear off more quickly? Run it over a pane of glass and see if it gets as hot as it does on the grindstone; if it wears down as quickly.

Why we oil machinery. We can decrease friction by keeping objects from pressing tightly against each other, and by making their surfaces smooth. The most common way of making surfaces smooth is by oiling or greasing them. A film of oil or grease makes things so smooth and slippery that there is very little friction. That is why all kinds of machinery will run so smoothly if they are kept oiled. And since the oil decreases friction, it decreases the wear caused by friction. So well-oiled machines last much longer than machines that are not sufficiently oiled.

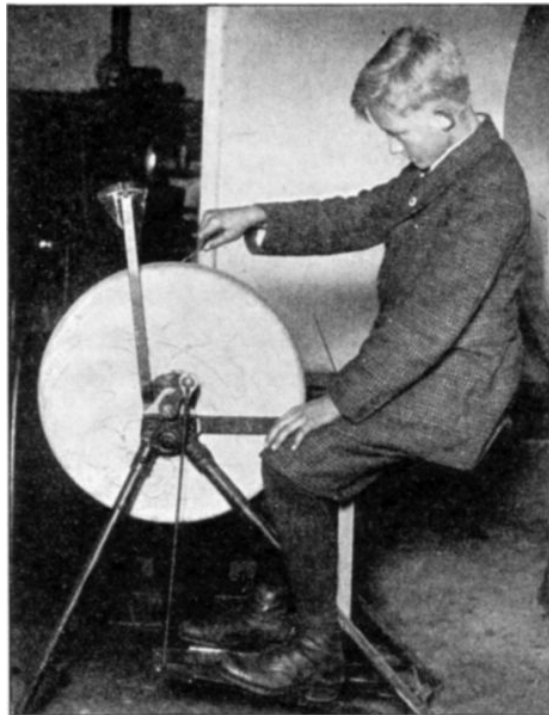

FIG. 25. The friction of the stone heats the nail and wears it away.

Why ball bearings are used. There is much less friction when a round object rolls over a surface than when two surfaces slide over one another, unless the sliding surfaces are very smooth; think how much easier it is to pull a wagon forward than it would be to take hold of the wheels and pull the wagon sidewise. So when you want the least possible friction in a machine you use ball bearings. The bearings are located in the hub of a wheel. Then, instead of the axle rubbing against the hub, the bearings roll inside of the hub. This causes very little friction; and the friction is made still less by keeping the bearings oiled.

Application 14. Suppose you were making a bicycle,—in which of the following places would you want to increase the friction, and in which would you want to decrease it? Handle grips, axles, pedals, tires, pedal cranks, the sockets in which the handle bar turns, the nuts that hold the parts together.

Application 15. A small boy decided to surprise his mother by oiling her sewing-machine. He put oil in the following places:

On the treadle, on the large wheel over which the belt runs, on the axle of the same wheel, on the groove in the little wheel up above where the belt runs, on the joint

where the needle runs up and down, on the little rough place under the needle that pushes the cloth forward. Which of these did he do well to oil and which should he have let alone?

Inference Exercise

Explain the following:

61. Rivers flow north as well as south, although we usually speak of north as "up north."
62. Tartar and bits of food stick to your teeth.
63. Brushing your teeth with tooth powder cleans them.
64. When a chair has gliders (smooth metal caps) on its feet, it slides easily across the floor.
65. When you wet your finger, you can turn a page more easily.
66. A lamp wick draws oil up from the lower part of a lamp to the burner.
67. The sidewalks on steep hills are made of rough cement.
68. Certain fish can rise in the water by expanding their air bladders, although this does not make them weigh any less.
69. When your hands are cold, you rub them together to warm them.
70. It is dangerous to stand up in a rowboat or canoe.

[pg 56]

[pg 57]

CHAPTER THREE

CONSERVATION OF ENERGY

SECTION 10. *Levers.*

How a big weight can be lifted with a little force; how one thing moving slowly a short distance can make another move swiftly a long distance.

Why can you go so much faster on a bicycle than on foot?

How can a man lift up a heavy automobile by using a jack?

Why can you crack a hard nut with a nutcracker when you cannot crack it by squeezing it between two pieces of iron?

"Give me a lever, long enough and strong enough, and something to rest it on, and I can lift the whole world," said an old Greek philosopher. And as a philosopher he was right; theoretically it would be possible. But since he needed a lever that would have been as long as from here to the farthest star whose distance has ever been measured, and since he would have had to push his end of the lever something like a quintillion (1,000,000,000,000,000,000) miles to lift the earth one inch, his proposition was hardly a practical one.

But levers are practical. Without them there would be none of our modern machines. No locomotives could speed across the continents; no derricks could lift great weights; no automobiles or bicycles would quicken our travel; our very bodies would be completely paralyzed. Yet the law back of all these things is really simple.

You have often noticed on the see-saw that a small child at one end can be balanced by a larger child at the other end, provided that the larger child sits nearer the middle. Why should it matter where the larger child sits? He is always heavier—why doesn't he overbalance the small child? It is because when the small child moves up and down he goes a longer distance than the large child does. In Figure 26 the large boy moves up and down only half as far as the little girl does. She weighs only half as much as he, yet she balances him.

[pg 58]



FIG. 26. The little girl raises the big boy, but in doing it she moves twice as far as he does.

You will begin to get a general understanding of levers and how they work by doing the following experiment:

Experiment 18. For this experiment there will be needed a small pail filled with something heavy (sand or stones will do), a yardstick with a hole through the middle and another hole near one end and with notches cut here and there along the edge, and a post or table corner with a heavy nail driven into it to within an inch of the head. The holes in the yardstick must be large enough to let the head of this nail through.

[pg 59]

Put the middle hole of the yardstick over the nail, as is shown in Figure 27. The nail is the *fulcrum* of your lever. Now hang the pail on one of the notches about halfway between the fulcrum and the end of the stick and put your hand on the opposite side of the yardstick at about the same distance as the pail is from the fulcrum. Raise and lower the pail several times by moving the opposite end of the lever up and down. See how much force it takes to move the pail.

Now slide your hand toward the fulcrum and lower and raise the pail from that position. Is it harder or easier to lift the pail from here than from the first position? Which moves farther up and down, your hand or the pail?

Next, slide your hand all the way out to the end of the yardstick and raise and lower the pail from there. Is the pail harder or easier to lift? Does the pail move a longer or a shorter distance up and down than your hand?

If you wanted to move the pail a long way without moving your hand as far, would you put your hand nearer to the fulcrum or farther from it than the pail is?

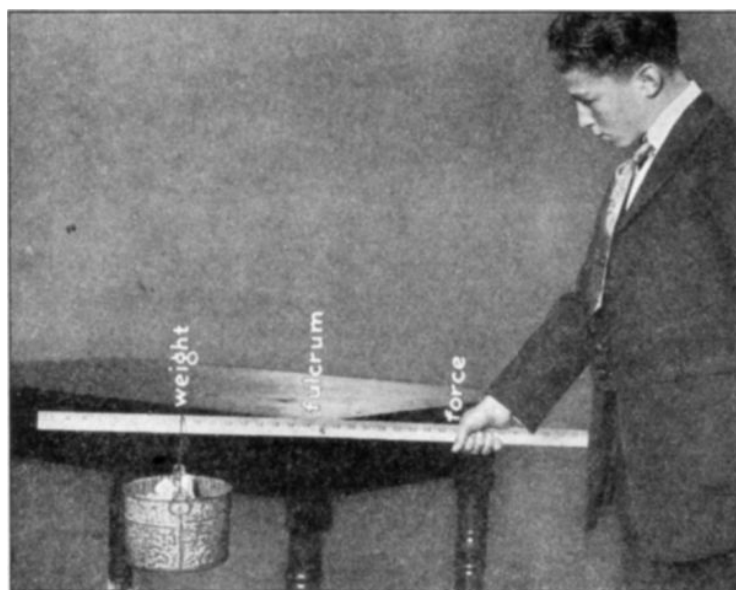

FIG. 27. The yardstick is a lever by which he lifts the pail.

[pg 60]

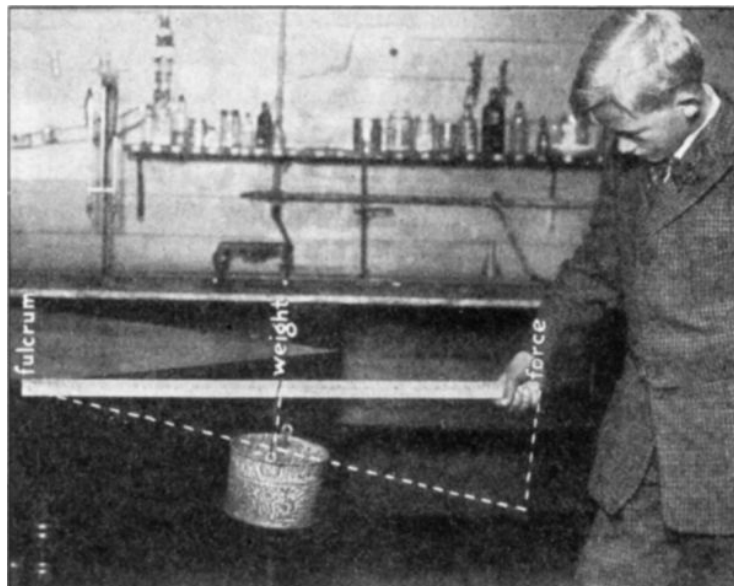

FIG. 28. A lever with the weight between the fulcrum and the force.

Suppose you wanted to lift the pail with the least possible effort, where would you put your hand?

Notice another fact: when your hand is at the end of the yardstick, it takes the same length of time to move a long way as the pail takes to move a short way. Then which is moving faster, your hand or the pail?

Experiment 19. Put the end hole of the yardstick on the nail, as shown in Figure 28. The nail is still the fulcrum of your lever. Put the pail about halfway between the fulcrum and the other end of the stick, and hold the end of the stick in your hands.

Raise and lower your hand to see how hard or how easy it is to lift the pail from this position. Which is moving farther, your hand or the pail? Which is moving faster?

Now put your hand about halfway between the fulcrum and the pail and raise and lower it. Is it harder or easier to raise than before? Which moves farther this time, your hand or the pail? Which moves faster?

[pg 61]

If you wanted to make the pail move farther and faster than your hand, would you put your hand nearer to the fulcrum than the pail is, or farther from the fulcrum than the pail? If you wanted to move the pail with the least effort, where would you put your hand?

Experiment 20. Use a pair of long-bladed shears and fold a piece of cardboard once to lie astride your own or some one else's finger. Put the finger, protected by the cardboard, between the two points of the shears. Then squeeze the handles of the shears together. See if you can bring the handles together hard enough to hurt the finger between the points.

Now watch the shears as you open and close the blades. Which move farther, the points of the shears or the handles? Which move faster?

Next, put the finger, still protected by the cardboard, between the *handles* of the shears and press the points together. Can you pinch the finger this way harder or less hard than in the way you first tried?



FIG. 29. You cannot pinch hard enough this way to hurt.

[pg 62]

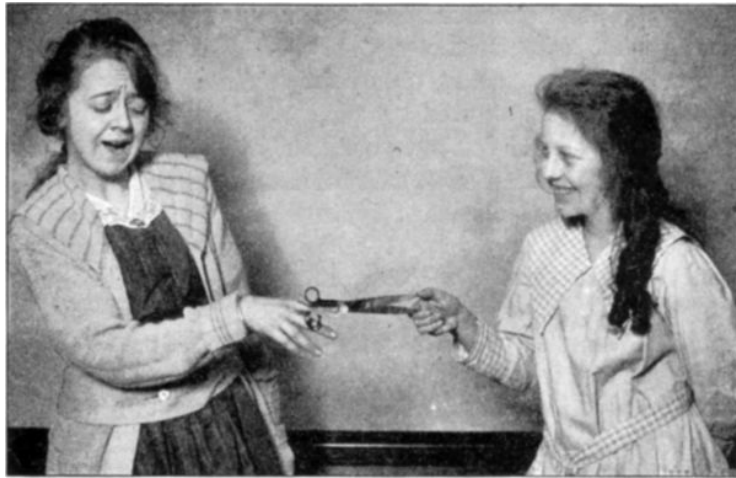

FIG. 30. But this is quite different.

Do the points or handles move farther as you close the shears? Which part closes with the greater force?

Experiment 21. Use a Dover egg beater. Fasten a small piece of string to one of the blades, so that you can tell how many times it goes around. Turn the handle of the beater around once slowly and count how many times the blade goes around. Which moves faster, the handle or the blade? Where would you expect to find more force, in the cogs or in the blades? Test your conclusion this way: Put your finger between the blades and try to pinch it by turning the handle; then place your finger so that the skin is caught between the cogs and try to pinch the finger by turning the blades. Where is there more force? Where is there more motion?



FIG. 31. When the handle is turned the blades of the egg beater move much more rapidly than the hand. Will they pinch hard enough to hurt?



FIG. 32. His hand goes down as far as the pail goes up.

the way you first tried? As you pull down with your hand, notice whether your hand moves farther than the pail, not so far as the pail, or the same distance. Is the greater amount of motion in your hand or in the pail? Then where would you expect the greater amount of force?

The whole idea of the lever can be summed up like this: one end of the contrivance *moves* more than the other. But energy cannot be lost; so to make up for this extra *motion* at one end more *force* is always exerted at the other.

This rule is true for all kinds of levers, blocks and tackles or pulley systems, automobile and bicycle gears, belt systems, cog systems, derricks, crowbars, and every kind of machine. In most machines you either put in more force than you get out and gain motion, or you put in more motion than you get out and gain force. In the following examples of the lever see if you can tell whether you are applying more force and obtaining more motion, or whether you are putting in more motion and obtaining more force:

Cracking nuts with a nut cracker.

Beating eggs with a Dover egg beater.

Going up a hill in an automobile on low gear.

Speeding on high gear.

Cutting cloth with the points of shears.

Cutting near the angle of the shears.

Turning a door knob.

Picking up sugar with sugar tongs.

Pinching your finger in the crack of a door on the hinge side.

Application 16. Suppose you wanted to lift a heavy frying pan off the stove. You have a cloth to keep it from burning your hand. Would it be easier to lift it by the end of the handle or by the part of the handle nearest the pan?

Application 17. A boy was going to wheel his little sister in a wheelbarrow. She wanted to sit in the middle of the wheelbarrow; her brother thought she should sit as near the handles as possible so that she would be nearer his hands. Another boy thought she should sit as near the wheel as possible. Who was right?

Application 18. James McDougal lived in a hilly place. He was going to buy a bicycle.

Experiment 22. Put a spool over the nail which was your fulcrum in the first two experiments. (Take the stick off the nail first, of course.) Use this spool as a pulley. Put a string over it and fasten one end of your string to the pail (Fig. 32). Lift the pail by pulling down on the other end of the string. Notice that it is not harder or easier to move the pail when it is near the nail than when it is near the floor. When your hand moves down from the nail to the floor, how far up does the pail move? Does the pail move a greater or less distance than your hand, or does it move the same distance?

Next fasten one end of the string to the nail. Set the pail on the floor. Pass the string through the handle of the pail and up over the spool (Fig. 33). Pull down on the loose end of the string. Is the pail easier to lift in this way or in



FIG. 33. With this arrangement the pail travels more slowly than the hand. Will it seem heavier or lighter than with the arrangement shown in Figure 32?

"I want one that will take the hills easily," he said. The dealer showed him two bicycles. On one the back wheel went around three times while the pedals went around once; on the other the back wheel went around four and a half times while the pedals went around once. Which bicycle should James have chosen? If he had wanted the bicycle for racing, which should he have chosen?

Application 19. A wagon stuck in the mud. The driver got out and tried to help the horse by grasping the spokes and turning the wheel. Should he have grasped the spokes near the hub, near the rim, or in the middle?

[pg 66]

Inference Exercise

Explain the following:

71. When you turn on the faucet of a distilled-water bottle, bubbles go up through the water as the water pours out.

72. A clothes wringer has a long handle. It wrings the clothes drier than you can wring them by hand.

73. You use a crowbar when you want to raise a heavy object such as a rock.

74. Sometimes it is almost impossible to get the top from a jar of canned fruit unless you let a little air under the edge of the lid.

75. It is much easier to carry a carpet sweeper if you take hold near the sweeper part than it is if you take hold at the end of the handle.

76. You can make marks on a paper by rubbing a pencil across it.

77. A motorman sands the track when he wishes to stop the car on a hill.

78. On a faucet there is a handle with which to turn it.

79. Before we pull candy we butter our fingers.

80. You can scratch glass with very hard steel but not with wood.

SECTION 11. *Inertia.*

Why is it that if you push a miniature auto rapidly, it will go straight?

Why does the earth never stop moving?

When you jerk a piece of paper from under an inkwell, why does the inkwell stay still?

When you are riding in a car and the car stops suddenly, you are thrown forward; your body tends to keep moving in the direction in which the car was going. When a car starts suddenly, you are thrown backward; your body tends to stay where it was before the car started.

[pg 67]

When an automobile bumps into anything, the people in the front seat are often thrown forward through the wind shield and are badly cut; their bodies keep on going in the direction in which the automobile was going.

When you jump off a moving street car, you have to run along in the direction the car was going or you fall down; your body tries to keep going in the same direction it was moving, and if your feet do not keep up, you topple forward.

Generally we think that it takes force to start things to move, but that they will stop of their own accord. This is not true. It takes just as much force to stop a thing as it does to start it, and what usually does the stopping is friction.

When you shoot a stone in a sling shot, the contracting rubber pulls the stone forward very rapidly. The stone has been started and it would go on and never stop if nothing interfered with it. For instance, if you should go away off in space—say halfway between here and a star—and shoot a stone from a sling shot, that stone would keep on going as fast as it was going when it left your sling shot, forever and ever, without stopping, unless it bumped into a star or something. On earth the reason it stops after a while is that it is bumping into something all the time—into the particles of air while it is in the air, and finally against the earth when it is pulled to the ground by gravity.

If you threw a ball on the moon, the person who caught it would have to have a very thick mitt to protect his hand, and it would never be safe to catch a batted fly. For there is no air on the moon, and therefore nothing would slow the ball down until it hit something; and it would be going as hard and fast when it struck the hand of the one who caught it as when it left your hand or the bat.

[pg 68]

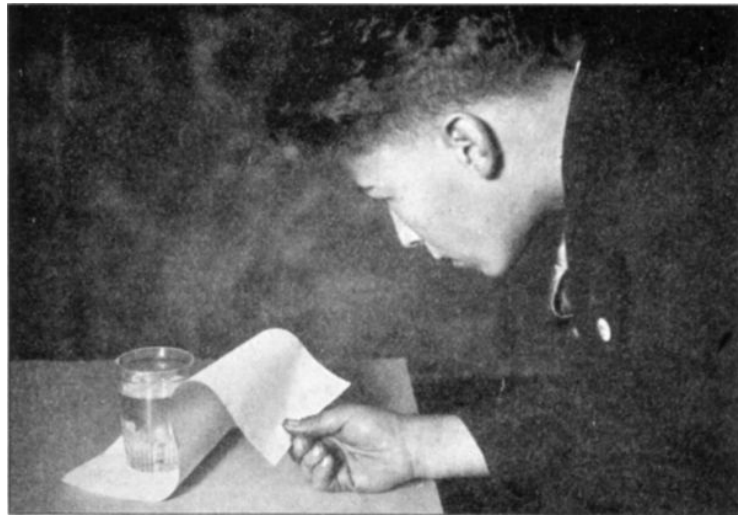

FIG. 34. When the paper is jerked out, the glass of water does not move.

Try these experiments:

Experiment 23. Fill a glass almost to the brim with water. Lay a smooth piece of writing paper 10 or 11 inches long on a smooth table, placing it near the edge of the table. Set the glass of water on the paper near its inner edge (Fig. 34).

Take hold of the edge of the paper that is near the edge of the table. Move your hand a little toward the glass so that the paper is somewhat bent. Then, keeping your hand near the level of the table, suddenly jerk the paper out from under the glass. If you give a quick enough jerk and keep your hand near the level of the table, not a drop of water will spill and the glass will stay almost exactly where it was.

This is because the glass of water has inertia. It was standing still, and so it tends to remain standing still. Your jerk was so sudden that there was not time to overcome the inertia of the glass of water; so it stayed where it was.

[pg 69]

Experiment 24. Have a boy on roller skates skate down the hall or sidewalk toward you and have him begin to coast as he comes near. When he reaches you, put out your arm and try to stop him. Notice how much force it takes to stop him in spite of the fact that he is no longer pushing himself along.

Now let the boy skate toward you again, coasting as before; but this time have him swing himself around a corner by taking hold of you as he passes. Notice how much force it takes just to change the direction in which he is moving.

You see the boy's inertia makes him tend to keep going straight ahead at the same speed; it resists any change either in the speed or the direction of his motion. So it takes a good deal of force either to stop him or to turn him.

If, on the other hand, *you* had no inertia, you could neither have stopped him nor turned him; he would have swept you right along with him. It was because inertia made you tend to remain still, that you could overcome part of his inertia. At the same time he overcame part of your inertia, for he made you move a little.

[pg 70]



FIG. 35. When a boy is moving rapidly, it takes force to change the direction of his motion.

Inertia is the tendency of a thing to keep on going forever in the same direction if once it is started, or to stand still forever unless something starts it. If moving things did not have inertia (if they did not tend to keep right on moving in the same direction forever or until *something* changed their motion), you could not throw a ball; the second you let go of it, it would stop and fall to the ground. You could not shoot a bullet any distance; as soon as the gases of the

gunpowder had stopped pushing against it, it would stop dead and fall. There would be no need of brakes on trains or automobiles; the instant the steam or gasoline was shut off, the train or auto would come to a dead stop. But you would not be jerked in the least by the stopping, because as soon as the automobile or train stopped, your body too would stop moving forward. Your automobile could even crash into a building without your being jarred. For when the machine came to a sudden stop, you would not be thrown forward at all, but would sit calmly in the undamaged automobile.

If you sat in a swing and some one ran under you, you would keep going up till he let go, and then you would be pulled down by gravity just as you now are. But just as soon as the swing was straight up and down you would stop; there would be no inertia to make you keep on swinging back and up.

[pg 71]

If the inertia of moving things stopped, the clocks would no longer run, the pendulums would no longer swing, nor the balance wheels turn; nothing could be thrown; it would be impossible to jump; there would cease to be waves on the ocean; and the moon would come tumbling to the earth. The earth would stop spinning; so there would be no change from day to night; and it would stop swinging about in its orbit and start on a rush toward the sun.

But there is always inertia. And all things everywhere and all the time tend to remain stock still if they are still, until some force makes them move; and all things that are moving tend to keep on moving at the same speed and in the same direction, until something stops them or turns them in another direction.

Application 20. Explain why you should face forward when alighting from a street car; why a croquet ball keeps rolling after you hit it; why you feel a jolt when you jump down from a high place.

Inference Exercise

Explain the following:

81. It is much easier to erase charcoal drawings than water-color paintings.
82. When an elevator starts down suddenly you feel lighter for a moment, while if it starts up quickly you feel heavier.
83. You can draw a nail with a claw hammer when you could not possibly pull it with your hand even if you could get hold of it.
84. When an automobile bumps into anything, the people in the front seat are often thrown forward through the wind shield.
85. Certain weighted dolls will rise and stand upright, no matter in what position you lay them down.
86. Some automobile tires have little rubber cups all over them which are supposed to make the tires cling to the pavement and thus prevent skidding.
87. It is hard to move beds and bureaus which have no castors or gliders.
88. When you jump off a moving street car, you lean back.
89. All water flows toward the oceans sooner or later.
90. You can skate on ice, but not on a sidewalk, with ice skates.

[pg 72]

SECTION 12. *Centrifugal force.*

Why does not the moon fall down to the earth?

Why will a lasso go so far after it is whirled?

Why does a top stand on its point while it is spinning?

If centrifugal force suddenly stopped acting, you would at first not notice any change. But if you happened to get into an automobile and rode down a muddy street, you would be delighted to find that the mud did not fly up from the wheels as you sped along. And when you went around a slippery corner, your automobile would not skid in the least.

If a dog came out of a pool of water and shook himself while centrifugal force was not acting, the water, instead of flying off in every direction, would merely drip down to the ground as if the dog were not shaking himself at all. A cowboy would find that he could no longer throw his lasso by whirling it around his head. A boy trying to spin his top would discover that the top would not stand on its point while spinning, any better than when it was not spinning.

These are little things, however. Most people would be quite unconscious of any change for some time. *Then*, as night came on and the full moon rose, it would look as if it were growing larger

and larger. It would seem slowly to swell and swell until it filled the whole sky. Then with a stupendous crash the moon would collide with the earth. Every one would be instantly killed. And it would be lucky for them that they were; for if any people survived the shock of the awful collision, they would be roasted to death by the heat produced by the striking together of the earth and the moon. Moreover, the earth would be whirled swiftly toward the sun, and a little later the charred earth would be swept into the sun's vast, tempestuous flames.

When we were talking about inertia, we said that if there were no inertia, the moon would tumble down to the earth and the earth, too, would fall into the sun. That was because if there were no inertia there would be no centrifugal force. For centrifugal force is not really a force at all, but it is one form of inertia—the inertia of whirling things. Do this experiment:

Experiment 25. Hold a pail half full of water in one hand. Swing it back and forth a couple of times; then swing it swiftly forward, up, and on around, bringing it down back of you (Fig. 36). Swing it around this way swiftly and evenly several times, finally stopping at the beginning of the up swing.



FIG. 36. Why doesn't the water spill out?

It is centrifugal force that keeps the water in the pail. It depends entirely on inertia. You see, while the pail is swinging upward rapidly, the water is moving up and tends by its inertia to keep right on moving in the same upward direction. Before you get it over your head, the tendency of the water to keep on going up is so strong that it pulls on your arm and hand and presses against the bottom of the pail above it. Its tendency to go on up is stronger than the downward pull of gravity. As you swing the pail on backward, the water of course has to move backward, too; so now it tends to keep on moving backward; and when the pail is starting down behind you, the water is tending to fly out in the backward direction in which it has just been going. Therefore it still pushes against the bottom of the pail and pulls away from your shoulder, which is in the center of the circle about which the pail is moving. By the time you have swung the pail on down, the water in it tends to keep going down, and it is still pulling away from your shoulder and pressing against the bottom of the pail.

In this way, during every instant the water tends to keep going in the direction in which it was going just the instant before. The result is that the water keeps pulling away from your shoulder as long as you keep swinging it around.

All whirling things tend to fly away from the center about which they are turning. This is the law of centrifugal force. The earth, for example, as it swings around the sun, tends to fly away from the center of its orbit. This tendency of the earth—its centrifugal force—keeps it from being drawn into the sun by the powerful pull of the sun's gravitation. At the same time it is this gravitation of the sun that keeps the earth from flying off into space, where we should all be frozen to icicles and lost in everlasting night. For if the sun's pull stopped, the earth would fly off as does a stone whirled from the end of a string, when you let go of the string.

The moon, in like manner, would fly away from the earth and sun if *gravitation* stopped pulling it, but it would crash into us if its *centrifugal force* did not keep it at a safe distance.

Have you ever sat on a spinning platform, sometimes called "the social whirl," in an amusement

park, and tried to stay on as it spun faster and faster? It is centrifugal force that makes you slide away from the center and off at the edge.

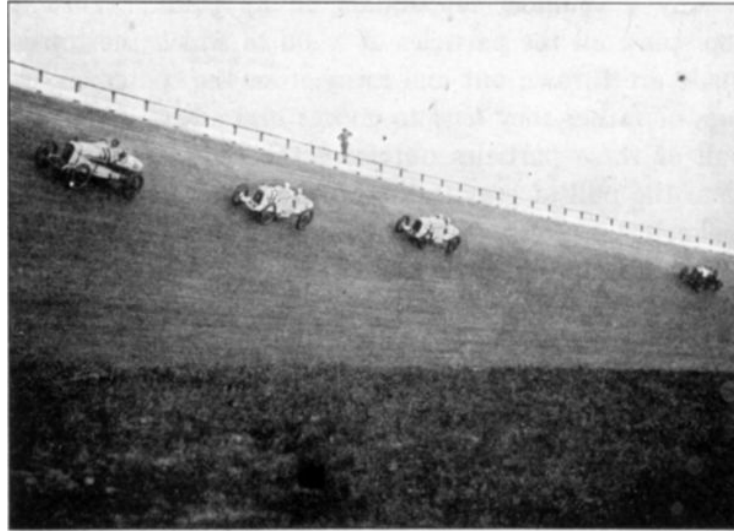

FIG. 37. An automobile race. Notice how the track is banked to keep the cars from overturning on the curves.

[pg 76]

How cream is separated from milk by centrifugal force. The heavier things are, the harder they are thrown out by centrifugal force. Milk is heavier than cream, as you know from the fact that cream rises and floats on top of the milk. So when milk is put into a centrifugal separator, a machine that whirls it around very rapidly, the milk is thrown to the outside harder than the cream, and the cream therefore stays nearer the middle. As the bowl of the machine whirls faster, the milk is thrown so hard against the outside that it flattens out and rises up the sides of the bowl. Thus you have a large hollow cylinder of milk on the outside against the wall of the bowl, while the whirling cream forms a smaller cylinder inside the cylinder of milk. By putting a spout on the machine so that it reaches the inner cylinder, the cream can be drawn off, while a spout not put in so far will draw off the milk.

Why a spinning top stands on its point. When a top spins, all the particles of wood of which the top is made are thrown out and away from the center of the top, or rather they *tend* to go out and away. And the pull of these particles out from the center is stronger than the pull of gravitation on the edges of the top to make it tip over; so it stands upright while it spins. Spin a top and see how this is.

Application 21. Explain how a motor cyclist can ride on an almost perpendicular wall in a circular race track. Explain how the earth keeps away from the sun, which is always powerfully pulling the earth toward it.

Inference Exercise

Explain the following:

91. As you tighten a screw it becomes harder to turn.
92. There is a process for partly drying food by whirling it rapidly in a perforated cylinder.
93. It is easier to climb mountains in hobnailed shoes than in smooth-soled ones.
94. When you bore a hole with a brace and bit, the hand that turns the brace goes around a circle many times as large as the hole that is being bored.
95. The hands of some persons become red and slightly swollen if they swing them while taking a long walk.
96. A flywheel keeps an engine going between the strokes of the piston.
97. In dry parts of the country farmers break up the surface of the soil frequently, as less water comes up to the surface through pulverized soil than would come through the fine pores of caked earth.
98. After you have apparently cleaned a grease spot out of a suit it often reappears when you have worn the suit a few days.
99. Mud flies up from the back wheel of a boy's bicycle when he rides along a wet street.

[pg 77]

100. A typewriter key goes down less than an inch, yet the type bar goes up nearly 5 inches.

SECTION 13. *Action and reaction.*

How can a bird fly? What makes it stay up in the air?

What makes a gun kick?

Why do you sink when you stop swimming?

Whenever anything moves, it pushes something else in an opposite direction. When you row a boat you can notice this; you see the oars pushing the water backward to push the boat forward. Also, when you shoot a bullet forward you can feel the gun kick backward; or when you pull down hard enough on a bar, your body rises up and you chin yourself. But the law is just as true for things which are not noticeable. When you walk, your feet push back against the earth; and if the earth were not so enormous and you so small, and if no one else were pushing in the opposite direction, you would see the earth spin back a little for each step you took forward, just as the big ball that a performing bear stands on turns backward as the bear tries to walk forward.

[pg 78]



FIG. 38. The horse goes forward by pushing backward on the earth with his feet.

The usual way of saying this is, "Action and reaction are equal and opposite." If you climb a rope, the upward movement of your body is the action; but you have to pull down on the rope to lift your body up. This is the reaction.

Without this law of action and reaction no fish could swim, no steamboat could push its way across the water, no bird could fly, no train or machine of any kind could move forward or backward, no man or animal could walk or crawl. The whole world of living things would be utterly paralyzed.

[pg 79]



FIG. 39. As he starts to toss the ball up, will he weigh more or less?

When *anything* starts to move, it does so by pushing on something else. When your arms start to move up, they do so by pushing your body down a little. When you swim, you push the water back and down with your arms and legs, and this pushes your body forward and up. When a bird flies up into the air, it pushes its body up by beating the air down with its wings. When an airplane whirs along, its propeller fans the air backward all the time. Street-car tracks are kept shiny by the wheels, which slip a little as they tend to shove the track backward in making the car move forward. Automobile tires wear out in much the same way,—they slip and are worn by friction as they move the earth back in pushing the automobile forward. In fact, if there are loose pebbles or mud on the road, you can see the pebbles or mud fly back, as the wheels of the automobile begin to turn rapidly and give their backward push to the earth beneath.

[pg 80]

Here are a couple of experiments that will show you action and reaction more clearly:

Experiment 26. Stand on a platform scale and weigh yourself. When the beam is exactly balanced, move your hands upward and notice whether you weigh more or less when they *start* up. Now move them downward; when they *start* down, do you weigh more or less? Toss a ball into the air, and watch your weight while you are tossing it. Does your body tend to go up or down while you are making the ball go up?



[pg 81]

Experiment 27. Go out into the yard and sit in a rope swing. Stop the swing entirely. Keep your feet off the ground all through the experiment. Now try to work yourself up in the swing; that is, make it swing by moving your legs and body and arms, but not by touching the ground. (Try to make it swing forward and backward only; when you try to swing sidewise, the distance between the ropes spoils the experiment.) See if you can figure out why the swing will not move back and forth. Notice your bodily motions; notice that when half of your body goes forward, half goes back; when you pull back with your hands, you push your body forward. If you watch yourself closely, you will see that every backward motion is exactly balanced by a forward motion of some part of your body.

Application 22. Explain why you push forward against the table to shove your chair back from it; why a bird beats down with its wings against the air to force itself up; why you push back on the water with your oars to make a rowboat go forward.

FIG. 40. Action and reaction are equal; when he pushes forward on the ropes, he pushes backward with equal force on the seat.

Inference Exercise

Explain the following:

101. Water comes up city pipes into your kitchen.

102. When you try to push a heavy trunk, your feet slip out from under you and slide in the opposite direction.

103. When you turn a bottle of water upside down with a small piece of cardboard laid over its mouth, the water stays in the bottle.

104. You can squeeze a thing very tightly in a vise.

105. There is a water game called "log rolling"; two men stand on a log floating in the water and roll the log around with their feet, each one trying to make the other lose his balance. Explain why the log rolls backward when the man apparently runs forward.

106. The oil which fills up the spaces between the parts of a duck's feathers keeps the duck from getting wet when a hen would be soaked.

107. Sleds run on snow more easily than wagons do.

108. In coasting down a hill, it is difficult to stop at the bottom.

109. When you light a pinwheel, the wheel whirls around as the powder burns, and the sparks fly off in all directions.

110. You cannot lift yourself by your own boot straps.

[pg 82]

SECTION 14. *Elasticity.*

What makes a ball bounce?

How does a springboard help you dive?

Why are automobile and bicycle tires filled with air?

Suppose there were a man who was perfectly elastic, and who made everything he touched perfectly elastic. Fortunately there is no such person, but suppose an elastic man *did* exist:

He walks with a spring and a bound; his feet bounce up like rubber balls each time they strike the earth; his legs snap back into place after each step as if pulled by a spring. If he stumbles and falls to the ground, he bounces back up into the air without a scar. (You see, his skin springs back into shape even if it is scratched, so that a scratch instantly heals.) And he bounces on and on forever without stopping.

Suppose you, seeing his plight, try to stop him. Since we are pretending that he makes everything he touches elastic, the instant you touch him you bounce helplessly away in the opposite direction.

You may think your clothes will be wrinkled by all this bouncing about, but since we are imagining that you have caught the elastic touch from the elastic man, your clothes which touch you likewise become perfectly elastic. So no matter how mussed they get, they promptly straighten out again to the condition they were in when you touched the elastic man.

If you notice that your shoe lace was untied just before you became elastic, and you now try to tie it and tuck it in, you find it most unmanageable. It insists upon flying out of your shoe and springing untied again.

[pg 83]

Perhaps your hair was mussed before you became elastic. Now it is impossible to comb it straight; each hair springs back like a fine steel wire.

If you take a handkerchief from your pocket to wipe your perspiring brow, you find that it does not stay unfolded. As soon as it is spread out on your hand, it snaps back to the shape and the folds it had while in your pocket.

Suppose you bounce up into an automobile for a ride. The automobile, now being made elastic by your magic touch, bounds up into the air at the first bump it strikes, and thereafter it goes hopping down the street in a most distressing manner, bouncing off the ground like a rubber ball each time it comes down. And each time it bumps you are thrown off the seat into the air.

You find it hard to stay in any new position. Your body always tends to snap back to the position you were in when you first became elastic. If you touch a trotting horse and it becomes elastic, the poor animal finds that his legs always straighten out to their trotting position, whether he wants to walk or stand still or lie down.

Imagine the plight of a boy pitching a ball, or some one yawning and stretching, or a clown turning a somersault, if you touch each of these just in the act and make him elastic. Their bodies always tend to snap back to these positions. Whenever the clown wants to rest, he has to get in the somersault position. The boy pitcher sleeps in the position of "winding up" to throw the ball. The one who was yawning and stretching has to be always on the alert, because the instant he

stops holding himself in some other position, his mouth flies open, his arms fly out, and every one thinks he is bored to death.

You might touch the clay that a sculptor is molding and make it elastic. The sculptor can mold all he pleases, but the clay is like rubber and always returns at once to its original shape.

If you make a tree elastic when a man is chopping it down, his ax bounces back from the tree with such force as nearly to knock him over, and no amount of chopping makes so much as a lasting dent in the tree.

Suppose you step in some mud. The mud does not stick to your shoes. It bends down under your weight, but springs back to form again as soon as your weight is removed.

And if you try to spread some elastic butter on bread, nothing will make the butter stay spread. The instant you remove your knife, the butter rolls up again into the same kind of lump it was in before.

As for chewing your bread, you might as well try to chew a rubber band. You force your jaws open, and they snap back on the bread all right; then they spring open again, and snap back and keep this up automatically until you make them stop. But for all this vigorous chewing your bread looks as if it had never been touched by a tooth.

Sewing is about as difficult. The thread springs into a coil in the shape of the spool. No hem stays turned; the cloth you try to sew springs into its original folds in a most exasperating manner.

On the whole, a perfectly elastic world would be a hopeless one to live in.

Elasticity is the tendency of a thing to go back to its original shape or size whenever it is forced into a different shape or size.

A thing does not have to be soft to be elastic. Steel is very elastic; that is why good springs are almost always made of steel. Glass is elastic; you know how you can bounce a glass marble. Rubber is elastic, too. Air is elastic in a different way; it does not go back to its original shape, since it has no shape, but if it has been compressed and the pressure is removed it immediately expands again; so a football or any such thing filled with air is decidedly elastic. That is why automobile and bicycle tires are filled with air; it makes the best possible "springs."

Balls bounce because they are elastic. When a ball strikes the ground, it is pushed out of shape. Since it is elastic it tries immediately to come back to its former shape, and so pushes out against the ground. This gives it such a push upward that it flies back to your hand.

Sometimes people confuse elasticity with action and reaction. But the differences between them are very clear. Action and reaction happen at the same time; your body goes up at the same time that you pull down on a bar to chin yourself; while in elasticity a thing moves first one way, then the other; you throw a ball down, *then* it comes back up to you. Another difference is that in action and reaction one thing moves one way and another thing is pushed the other way; while in elasticity the same thing moves first one way, then the other. If you press down on a spring scale with your hand, you are lifting up your body a little to do it; that is action and reaction. But after you take your hand off the scale the pan springs back up: first it was pushed down, then it springs back to its original position; it does this because of the elasticity of its spring.

Application 23. Explain why basket balls are filled with air; why springs are usually made of steel; why we use rubber bands to hold papers together; why a toy balloon becomes small again when you let the air out.

Inference Exercise

Explain the following, being especially careful not to confuse action and reaction with elasticity:

111. When you want to push your chair back from a table, you push forward against the table.

112. The pans in which candy is cooled must be greased.

113. Good springs make a bed comfortable.

114. Paper clips are made of steel or spring brass.

115. A spring door latch acts by itself if you close the door tightly.

116. On a cold morning, you rub your hands together to warm them.

117. If an electric fan is not fastened in place and has not a heavy base, it will move backward while it is going.

118. Doors with springs on them will close after you.

119. When you jump down on the end of a springboard, it throws you into the air.

120. You move your hands backward to swim forward.

NOTE. There are really two kinds of elasticity, which have nothing to do with each other. Elasticity of *form* is the tendency of a thing to go back to its original shape, as rubber does. If you make a dent in rubber, it springs right back to the shape it had before. Elasticity of *volume* is the tendency of a substance to go back to its original *size*, as lead does. If you manage to squeeze lead into a smaller space, it will spring right back to the same size as soon as you stop pressing it on all sides. But a dent in lead will stay there; it has little elasticity of form.

[pg 87]

Air and water—all liquids, in fact—have a great deal of elasticity of *volume*, but practically no elasticity of form. They do not tend to keep their shape, but they do tend to fill the same amount of space. Putty and clay likewise have very little elasticity of form; when you change their shape, they stay changed.

Jelly and steel and glass have a great deal of elasticity of *form*. When you dent them or twist them or in any way change their shape, they go right back to their first shape as soon as they can.

When we imagined a man with an "elastic touch," we were imagining a man who gave everything he touched perfect elasticity of *form*. It is elasticity of *form* that most people mean when they talk about elasticity.

[pg 88]

CHAPTER FOUR

HEAT

SECTION 15. *Heat makes things expand.*

How does a thermometer work? What makes the mercury rise in it?

Why does heat make things get larger?

When we look at objects through a microscope, they appear much larger and in many cases we are able to see the smaller parts of which they are made. If we had a microscope so powerful that it made a tiny speck of dust look as big as a mountain (of course no such microscope exists), and if we looked through this imaginary microscope at a piece of iron, we should find to our surprise that the particles were not standing still. The iron would probably look as if it were fairly alive with millions of tiny specks moving back and forth, back and forth, faster than the flutter of an insect's wings.

[pg 89]

These tiny moving things are *molecules*. Everything in the world is made of them. It seems strange that we should know this, since there really are no microscopes nearly powerful enough to show the molecules to us. Yet scientists know a great deal about them. They have devised all sorts of elaborate experiments—very accurate ones—and have tested the theories about molecules in many ways. They have said, for instance, "Now, if this thing *is* made of molecules, then it will grow larger when we make the molecules move faster by heating it." Then they heated it—in your next experiment you will see what happened. This is only one of thousands of experiments they have performed, measuring over and over again, with the greatest care, exactly *how much* an object expanded when it was heated a certain amount; exactly how much heat was needed to change water to steam; exactly how far a piece of steel of a certain size and shape could bend without breaking; exactly how crystals form—and so on and so on. And they have always found that everything acts as if it were made of moving molecules. Their experiments have been so careful and scientists have found out so much about what *seem* to be molecules,—how large they are, what they probably weigh, how fast they move, and even what they are made of,—that almost no one has any doubt left that fast-moving molecules make up everything in the world.



FIG. 41. A thermometer.

[pg 90]

To go back, then: if we looked at a piece of iron under a microscope that would show us the molecules,—and remember, no such powerful microscope could exist,—we should see these quivering particles, and nothing more. Then if some one heated the iron while we watched the molecules, or if the sun shone on it, we should see the molecules move faster and faster and separate farther and farther. That is why heat expands things. When the molecules in an object move farther apart, naturally the object expands.

Heat is the motion of the molecules. When the molecules move faster (that is, when the iron grows hotter), they separate farther and the iron swells.

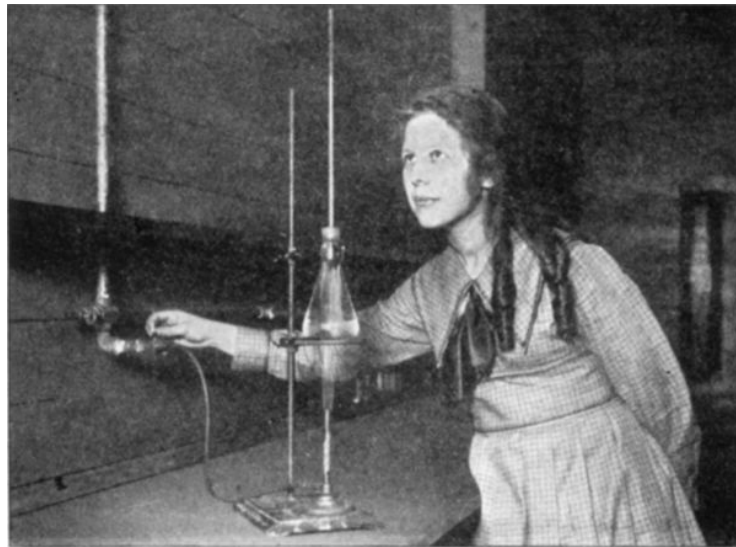

FIG. 42. A thermometer made of a flask of water. It does not show the exact degree of heat of the water, but it does show whether the water is hot or cold.

[pg 91]

How we can tell the temperature by reading a thermometer. The mercury (quicksilver) in the bulb of the thermometer like everything else expands (swells) when it becomes warm. It is shut in tightly on all sides by the glass, except for the little opening into the tube above. When it expands it must have more room, and the only space into which it can move is up in the tube. So it rises in the tube.



FIG. 43. Will the hot ball go through the ring?

Water will do the same thing. You can make a sort of thermometer, using water instead of mercury, and watch the water expand when you heat it. Here are the directions for doing this:

[pg 92]

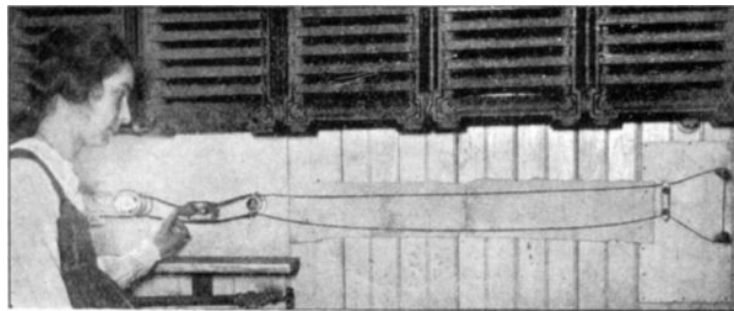

FIG. 44. When the wire is cold, it is fairly tight.

Experiment 28. Fill a flask to the top with water. Put a piece of glass tubing through a stopper, letting the tube stick 8 or 10 inches above the top of the stopper. Put the stopper into the flask, keeping out all air; the water may rise 2 or 3 inches in the glass tube. Dry the flask on the outside and put it on a screen on the stove or ring stand, and heat it. Watch the water in the tube. What effect does heat have on the water?

Here are two interesting experiments that show how solid things expand when they are heated:

Experiment 29. The brass ball and brass ring shown in Figure 43 are called the expansion ball and ring. Try pushing the ball through the ring. Now heat the ball over the flame for a minute or two—it should not be red hot—and try again to pass it through the ring.

Heat both ball and ring for a short time. Does heating expand the ring?

Experiment 30. Go to the electric apparatus (described on page 379) and turn on the switch that lets the electricity flow through the long resistance wire. Watch the wire as it becomes hot.

Application 24. A woman brought me a glass-stoppered bottle of smelling salts and asked me if I could open it. The stopper was in so tightly that I could not pull it out. I might have done any of the following things: Tried to pull the stopper out with a pair of pliers; plunged the bottle up to the neck in hot water; plunged it in ice-cold water; tried to loosen the stopper by tapping it all around. Which would have been the best way or ways?

[pg 93]

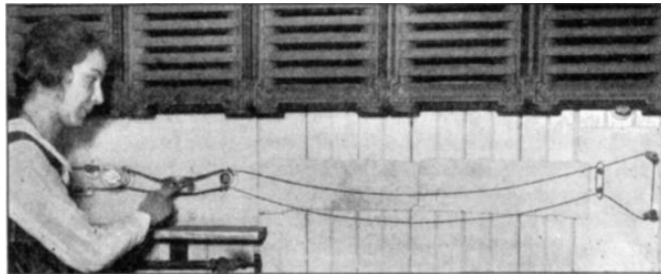

FIG. 45. But notice how it sags when it is hot.

Application 25. I used to buy a quart of milk each evening from a farmer just after he had milked. He cooled most of the milk as soon as it was strained, to make it keep better. He asked me if I wanted my quart before or after it was cooled. Either way he would fill his quart measure brim full. Which way would I have received more milk for my money?

Inference Exercise

Explain the following:

121. Billiard balls will rebound from each other and from the edges of the table again and again and finally stop.

122. In washing a tumbler in hot water it is necessary to lay it in sidewise and wet it all over, inside and out, to keep it from cracking; if it is thick in some parts and thin in others, like a cut-glass tumbler, it is not safe to wash it in hot water at all.

123. The swinging of the moon around the earth keeps the moon from falling to the earth.

124. A fire in a grate creates a draft up the chimney.

[pg 94]

125. Telegraph wires and wire fences put up in the summer must not be strung too tightly.

126. Candy usually draws in somewhat from the edge of the pan as it hardens.

127. A meat chopper can be screwed to a table more tightly than you can possibly push it on.

128. A floor covered with linoleum is more easily kept clean than a plain wood floor.

129. Rough seams on the inside of clothes chafe your skin.

130. You can take the top off a bottle of soda pop with an opener that will pry it up, but you cannot pull it off with your fingers.

SECTION 16. *Cooling from expansion.*

We get our heat from the sun; then why is it so cold up on the mountain tops?

What is coldness?

Here is an interesting and rather strange thing about heat and expansion. Although heat expands things, yet expansion does not heat them. On the contrary, if a thing expands without being heated from an outside source, it actually gets cold! You see, in order to expand, it has to push the air or something else aside, and it actually uses up the energy of its own heat to do this. You will understand this better after you do the next experiment.

Experiment 31. Wet the inside of a test tube. Hold the mouth of the test tube against the opening of a carbon dioxide tank. Open the valve of the tank with the wrench and let the compressed gas rush out into the test tube until the mouth of the test tube is white. Shut off the valve. Feel your test tube.

[pg 95]

What has happened is this: The gas was tightly compressed in the tank. It was not cold; that is, it had some heat in it, as everything has. When you let it loose, it used up much of its heat in pushing the air in the test tube and all around it out of the way. In this way it lost its heat, and then it became cold. *Cold means absence of heat*, as dark means absence of light. So when the compressed gas used up its heat in pushing the air out of its way, it became so cold that it froze the water in your test tube.



FIG. 46. The expansion of the compressed gas freezes the moisture on the tube.

One reason why it is always cold high up in the air. Even on hot summer days aviators who fly high suffer from the cold. You might think that they would get warmer as they went up nearer the sun; one reason that they get colder instead is this:

[pg 96]

As you saw in the last experiment, a gas that expands gets very cold. Air is a kind of gas. And whenever air rises to where there is not so much air crowding down on it from above, it expands. So the air that rises high and expands gets very cold. Consequently mountains which reach up into this high, cold air are snow covered all the year round; and aviators who fly high suffer keenly from the cold. There are several reasons for this coldness of the high air. This is just *one* of them.

Application 26. Explain why air usually cools when it rises; why high mountain tops are always covered with snow.

Inference Exercise

Explain the following:

131. You should not fill a teakettle brim full of cold water when you are going to put it on the stove.
132. It is harder to erase an ink mark than a pencil mark.
133. Bearings of good watches, where there is constant rubbing on the parts, are made of very hard jewels.
134. You feel lighter for an instant when you are in an elevator which starts down suddenly.
135. When men lay cement sidewalks, they almost always make cracks across them every few feet.
136. To cool hot coffee one sometimes blows on it.
137. It is much easier to turn the latch of a door with the knob than with the spindle when the knob is off.
138. Patent-leather shoes do not soil as easily as plain leather shoes.
139. We use rubber bands to hold things together tightly.
140. As air goes up it usually cools.

SECTION 17. *Freezing and melting.*

When water freezes in a pipe, why does the pipe burst?

What is liquid air?

Why does not the wire in an electric lamp melt when it is red hot?

[pg 97]

Suppose we looked at a piece of ice through the imaginary microscope that shows us the molecules. The ice molecules would be different from the iron molecules in size, but they would be vibrating back and forth in exactly the same way, only with less motion. It is because they have less motion that we say the ice is colder than the iron. Then let us suppose that the sun was

shining on the ice while we watched the ice molecules.

First we should see movements of the ice molecules become gradually more rapid, just as the iron molecules did when the iron was warmed. Then, as they moved faster and faster, they would begin to bump into each other and go around every which way, each molecule bumping first into one neighbor, then into another, and bouncing back in a new direction after each collision. This is what causes the ice to melt. When its molecules no longer go back and forth in the same path all the time, the ice no longer keeps its shape, and we call it water—a liquid.

Almost all solid substances will melt when they are heated. Or, to put it the other way around, every liquid will freeze solid if it gets cold enough. Even liquid air (which is ordinary air cooled and compressed until it runs like water) can be frozen into a solid chunk. Some things will melt while they are still very cold; solid air, for instance, melts at a temperature that would freeze you into an icicle before you could count ten. Other things, such as stones, are melted only by terrific heat.

[pg 98]

When the little particles of water that make up the clouds become very cold, they freeze as they gather and so make snowflakes. When the little particles of water in the air, that usually make dew, freeze while they are gathering on a blade of grass, we call it frost. When raindrops are carried up into colder, higher air while they are forming, they freeze and turn to hail. When snow or frost or hail or ice is heated, it melts and turns back to water.



FIG. 47. Why did the bottle break when the water in it turned to ice?

But here is a strange fact: although heat usually expands things, water expands when it *freezes*. Like everything else, however, water also expands when it becomes hot, as you found when you made a kind of thermometer, using a flask of water and a glass tube. But if you should put that flask into a freezing mixture of ice and salt, you would find that when the water became very cold it would begin to expand a little immediately before it froze.

[pg 99]

And it is very lucky for us that water does expand when it freezes, because if it did not, ice would be heavier than water is. But since the water expands as it freezes, ice weighs less than water and floats. And that is why lakes and oceans and rivers freeze over the top and do not freeze at the bottom. If they froze from the bottom up, as they would if the ice sank as it formed, every river and lake would be solid ice in the winter. All the harbors outside the tropics would probably be ice-bound all winter long. And the ice in the bottom of the lakes and rivers and in the ocean would probably never melt.

So in the case of freezing water, and in the case of a couple of metals, there is a point where coldness, not heat, makes things expand.

Experiment 32. Take a ketchup bottle with a screw cap and a cork that fits tightly. Fill it to the top with water; put a long pin beside the cork while you insert it, so that the water can be crowded out as the cork goes down; then when you have pushed the cork in tightly, pull out the pin. Screw the cap on the bottle so as to hold the cork fast. Put the bottle in a pail or box, and pack ice and salt around it. Within an hour you should be able to see what the freezing water does to the bottle.

Application 27. Explain why ice is lighter than water; why we have no snow in summer.

Inference Exercise

Explain the following:

141. Sealing wax is held over a candle flame before it is applied to a letter.
142. Automobile tires tighten upon a sudden change from cold weather to hot.
143. When paper has been rolled, it tends to curl up again after being unrolled.
144. Seats running across a car are much more comfortable when a car starts and stops, than are seats running along the sides.
145. You cannot siphon water from a low place to a higher one.
146. Candles get soft in hot weather.
147. Meteorites fall to the earth from the sky.
148. When you preserve fruit and pour the hot fruit into the jars, you fill the jars brim full and screw on the cap air-tight; yet a few hours later the fruit does not fill the jars; there is some empty space between the top of the fruit and the cover.
149. Water pipes burst in the winter when it is very cold.
150. When people want to make iron castings, they first melt the iron, then pour it into molds. They leave it in the molds until cold. After that the iron holds the shape of the molds. Explain why the iron changes from a liquid to a solid.

SECTION 18. *Evaporation.*

Why is it that when ink is spilled it dries up, but when it is in the bottle it does not dry up?

What put the salt into the ocean?

Why do you feel cold when you get out of the bathtub?

Wet clothes get dry when they are hung on the clothes-line. The water in them *evaporates*. It turns to invisible vapor and disappears into the air. Water and all liquids evaporate when they are long exposed to the air. If they didn't—well, let us imagine what the world would be like if all evaporation should suddenly stop:

You find that your face is perspiring and your hands as well. You wipe them on your handkerchief, but soon they are moist again, no matter how cool the weather. After wiping them a few more times your handkerchief becomes soaking wet, and you hang it up to dry. There may be a good breeze stirring, yet your handkerchief does not get dry. By this time the perspiration is running off your face and hands, and your underclothes are getting drenched with perspiration.

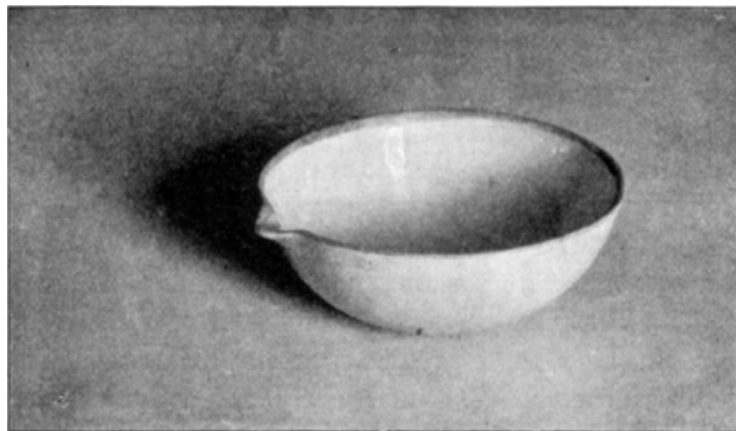

FIG. 48. An evaporating dish.

You hurry into the house, change your clothes, bathe and wipe yourself dry with a towel. When you find that your wet things are not drying, and that your dry ones are rapidly becoming moist, you hastily build a fire and hang your clothes beside it. No use, your clothes remain as wet as ever. If you get them very hot the moisture in them will boil and turn to steam, of course, but the steam will all turn back to water as soon as it cools a little and the drops will cling to your clothes

and to everything around the room. You will have to get used to living in wet clothes. You won't catch cold, though, since there is no evaporation to use up your heat.

But the water problem outside is not one of mere inconvenience. It never rains. How can it when the water from the oceans cannot evaporate to form clouds? Little by little the rivers begin to run dry—there is no rain to feed them. No fog blows in from the sea; no clouds cool the sun's glare; no dew moistens the grass at night; no frost shows the coming of cold weather; no snow comes to cover the mountains. In time there is no water left in the rivers; every lake with an outlet runs dry. There are no springs, and, after a while, no wells. People have to live on juicy plants. The crops fortunately require very little moisture, since none evaporates from them or from the ground in which they grow. And the people do not need nearly as much water to drink.

Little by little, however, the water all soaks too deep into the ground for the plants to get it. Gradually the continents become great deserts, and all life perishes from the land.

All these things would really happen, and many more changes besides, if water did not evaporate. Yet the evaporation of water is a very simple occurrence. As the molecules of any liquid bounce around, some get hit harder than others. These are shot off from the rest up into the air, and get too far away to be drawn back by the pull of the molecules behind. This shooting away of some of the molecules is evaporation. And since it takes heat to send these molecules flying off, the liquid that is left behind is colder because of the evaporation. That is why you are always cold after you leave the bathtub until you are dry. The water that evaporates from your body uses up a good deal of your heat.

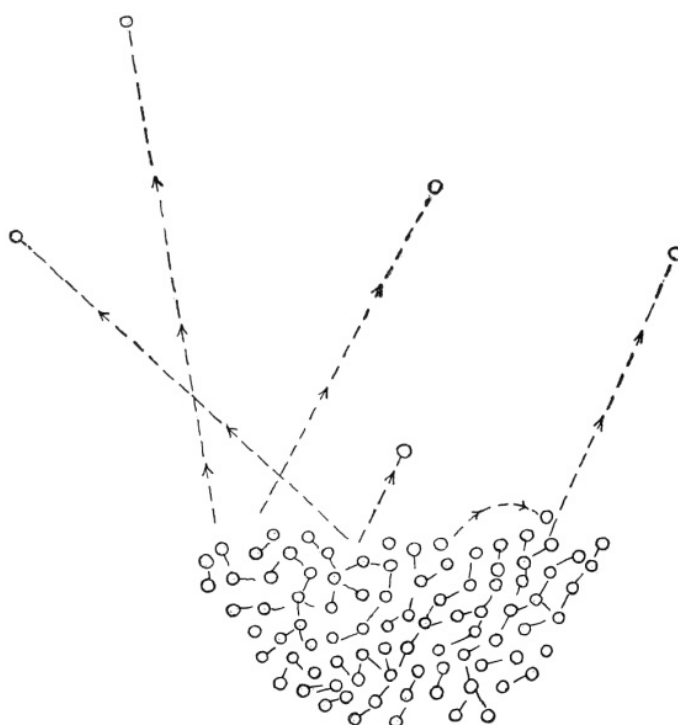

FIG. 49. Diagram illustrating how in the evaporation of water some of the molecules shoot off into the air.

Gasoline evaporates more quickly than water. That is why your hands become so cold when you get them wet with gasoline.

Since heat is required to evaporate a liquid, the quickest way to dry anything is to warm it. That is why you hang clothes in the sun or by the stove to dry.

Try these experiments:

Experiment 33. Read a thermometer that has been exposed to the room air. Now dip it in water that is warmer than the air, taking it out again at once. Watch the mercury. Does the thermometer register a higher or a lower temperature than it did at the beginning? What is taking up the heat from the mercury?

Experiment 34. Put a few drops of water in each of two evaporating dishes. Leave one cold; warm the other over the burner, but do not heat it to boiling. Which evaporates more quickly?

Why the sea is salt. You remember various fairy stories about why the sea is salt. For a long time the saltiness of the sea puzzled people. But the explanation is simple. As the water from the rains seeps through the soil and rocks, it dissolves the salt in them and continually carries some of it into the rivers. So the waters of the rivers always carry a very little salt with them out to sea.

The water in the ocean evaporates and leaves the salt behind. For millions of years this has been going on. So the rivers and lakes, which have only a little salt in them, keep adding their small amounts to the sea, and once in the sea the salt never can get out. The oceans never get any fuller of water, because water only flows into the ocean as fast as it evaporates from the ocean. Yet more salt goes into the ocean all the time, washed down by thousands of streams and rivers. So little by little the ocean has been growing more and more salty since the world began.

[pg 105]



FIG. 50. A view of the Dead Sea.

Great Salt Lake and the Dead Sea, unlike most lakes, have no rivers flowing out of them to carry the salt and water away, but rivers flow into them and bring along small amounts of salt all the time. Then the water evaporates from Great Salt Lake and the Dead Sea, leaving the salt behind; and that is why they are so very salty.

When people want to get the salt out of sea water, they put the sea water in shallow open tanks and let the water evaporate. The salt is left behind.

Experiment 35. Dissolve some salt in warm water until no more will dissolve. Pour the clear liquid off into an evaporating dish, being careful not to let any solid particles of the salt go over. Either set the dish aside uncovered, for several days, or heat it almost to boiling and let it evaporate to dryness. What is left in the dish?

Application 28. Some girls were heating water for tea, and were in a hurry. They had only an open stew pan to heat the water in.

[pg 106]

"Cover the pan with something; you'll let all the heat out!" Helen said.

"No, you want as much heat to go through the water as possible. Leave the lid off so that the heat can flow through easily," said Rose.

"The water will evaporate too fast if the lid is off, and all the heat will be used up in making it evaporate; it will take it much longer to get hot without the lid," Louise argued.

"That's not right," Rose answered. "Boiling water evaporates fastest of all. We want this to boil, so let it evaporate; leave the lid off."

What should they have done?

Application 29. Two men were about to cross a desert. They had their supply of water in canvas water bags that leaked just enough to keep the outside of the bags wet. Naturally they wanted to keep the water as cold as possible.

"I'm going to wrap my rubber poncho around my water bag and keep the hot desert air away from the water," said one.

"I'm not. I'm going to leave mine open to the air," the other said.

Which man was right? Why?

Inference Exercise

Explain the following:

151. When you go up high in an elevator, you feel the pressure of the air in your ears.

152. Water is always flowing into Great Salt Lake; it has no outlet; yet it is getting more

nearly empty all the time.

153. A nail sinks while a cork floats in water.

154. Steep hillsides are paved with cobblestones instead of asphalt.

155. If you place one wet glass tumbler inside another you can pull them apart only with difficulty, and frequently you break the outer one in the attempt.

156. Sausages often break their skins when they are being cooked.

157. A drop of water splashed against a hot lamp chimney cracks it.

[pg 107]

158. When you shoot an air gun, the air is compressed at first; then when it is released it springs out to its original volume and throws the bullet ahead of it.

159. Leather soles get wet through in rainy weather, while rubbers remain perfectly dry on the inside.

160. When you want to clean a wooden floor, you scrub it with a brush.

SECTION 19. *Boiling and condensing.*

What makes a geyser spout?

How does a steam engine go?

Once more let us imagine we are looking at molecules of water through our magical microscope. But this time suppose that the water has been made very hot. If we could watch the molecules smash into each other and bound about more and more madly, suddenly we should see large numbers of them go shooting off from the rest like rifle bullets, and they would fly out through the seemingly great spaces between the slower molecules of air. This would mean that the water was boiling and turning to steam.

Here are a couple of experiments that will show you how much more room water takes when it turns to steam than while it remains just water:

Experiment 36. Pour a half inch of water into the bottom of a test tube. Put a cork in the test tube so tightly that it will not let any steam pass it, but not too tightly. Hold the test tube with a test-tube clamp at arm's length over a flame, pointing the cork away from you. Wait for results.

[pg 108]

The reason the cork flew out of the test tube is this: Steam takes a great deal more room than water does,—many times as much room; so when the water in the test tube turned to steam, the steam had to get out and pushed the cork out ahead of it.

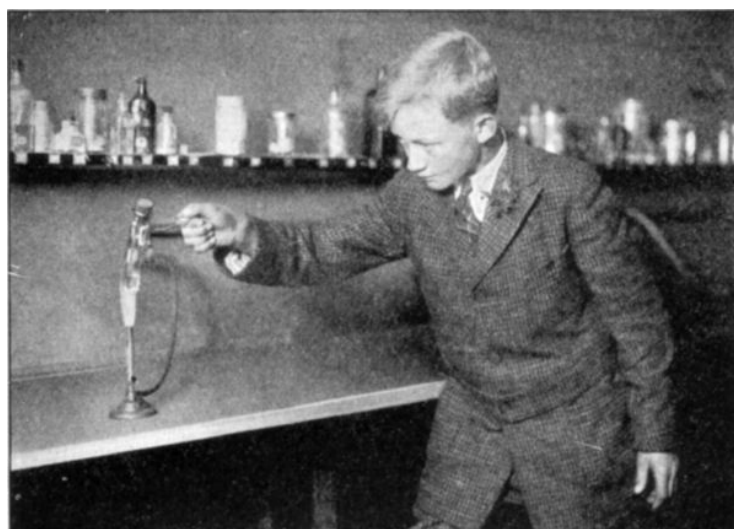

FIG. 51. In a minute the cork will fly out.

Experiment 37. Pour about half an inch of water into the bottom of a flask. Bring it to a vigorous boil over the burner and let it boil half a minute. Now take the flask off the flame and quickly slip the mouth of a toy balloon over the mouth of the flask. Watch what happens. If things go too slowly, you can speed them up by stroking the outside of the flask with a cold, wet cloth.

When the balloon has been drawn into the flask as far as it will go, you can put the flask back on the burner and heat the water till it boils. When the balloon has been forced

out of the flask again and begins to grow large, take the flask off the burner. Do this before the balloon explodes.

[pg 110]

The reason the balloon was drawn into the flask was that the steam in the flask turned back to water as it cooled, and took very much less space. This left a vacuum or empty space in the flask. What pushed the balloon into the empty space?



FIG. 52. A toy balloon has been slipped over the mouth of a flask that is filled with steam.



FIG. 53. As the steam condenses and leaves a vacuum, the air pressure forces the balloon into the flask.

How steam makes an engine go. The force of steam is entirely due to the fact that steam takes so much more room than the water from which it is made. A locomotive pulls trains across continents by using this force, and by the same force a ship carries thousands of tons of freight across the ocean. The engines of the locomotive and the ship are worked by the push of steam. A fire is built under a boiler. The water is boiled; the steam is shut in; the only way the steam can get out is by pushing the piston ahead of it; the piston is attached to machinery that makes the locomotive or ship move.

One theory about the cause of volcanoes. The water that sinks deep down into some of the hot parts of the earth turns to steam, takes up more room, and forces the water above it out as a geyser. It is thought by some scientists that volcanoes may be started by the water in the ocean seeping down through cracks to hot interior parts of the world where even the stone is melted; then the water, turning to steam, pushes its way up to the surface, forcing dust and stone ahead of it, and making a passage up for the melted stone, or lava. The persons who hold this view call attention to the fact that volcanoes are always in or near the sea. If this is the true explanation of volcanoes, then we should have no volcanoes if steam did not take more room than does the water from which it comes.

[pg 111]

Here is a very practical fact about boiling water that many people do not know; and their gas bills would be much smaller if they knew it. Try this experiment:



FIG. 54. Will boiling water get hotter if you make it boil harder?

Experiment 38. Heat some water to boiling. Put the boiling-point thermometer into the water (the thermometer graduated to 110° Centigrade and 220° Fahrenheit), and note the temperature of the boiling water. Turn up the gas and make the water boil as violently as possible. Read the thermometer. Does the water become appreciably hotter over the very hot fire than it does over the low fire, if it is boiling in both cases? But in which case is more steam given off? Will a very hot fire make the water boil away more rapidly than a low fire?

[pg 112]

When you are cooking potatoes, are you trying to keep them very hot or are you trying to boil the water away from them? Which are you trying to do in making candy, to keep the sugar very hot or to boil the water away from it?

All the extra heat you put into boiling water goes toward changing the water into steam; it cannot raise the water's temperature, because at the moment when water gets above the boiling point it ceases to be water and becomes steam. This steam takes up much more room than the water did, so it passes off into the air. You can tell when a teakettle boils by watching the spout to see when the steam³ pours forth from it in a strong, steady stream. If the steam took no more room than the water, it could stay in the kettle as easily as the water.

Footnote 3: What you see is really not the steam, but the vapor formed as the steam condenses in the cool room. The steam itself is invisible, as you can tell by looking at the mouth of the spout of a kettle of boiling water. You will see a clear space before the white vapor begins. The clear space is steam.

Distilling. When liquids are mixed together and dissolved in each other, it looks as if it would be impossible to take them apart. But it isn't. They can usually be separated almost perfectly by simply boiling them and collecting their vapor. For different substances boil at different temperatures just as they melt at different temperatures. Liquid air will boil on a cake of ice; it takes the intense heat of the electric furnace to boil melted iron. Alcohol boils at a lower temperature than water; gasoline boils at a lower temperature than kerosene. And people make a great deal of practical use of these facts when they wish to separate substances which have different boiling temperatures. They call this distilling. You can do some distilling yourself and separate a mixture of alcohol and water in the following manner:

[pg 113]

Experiment 39. First, pour a little alcohol into a cup—a few drops is enough—and touch a lighted match to it. Will it burn? Now mix two teaspoonfuls of alcohol with about half a cup of water and enough blueing to color the mixture. Pour a few drops of this mixture into the cup and try to light it. Will it burn?

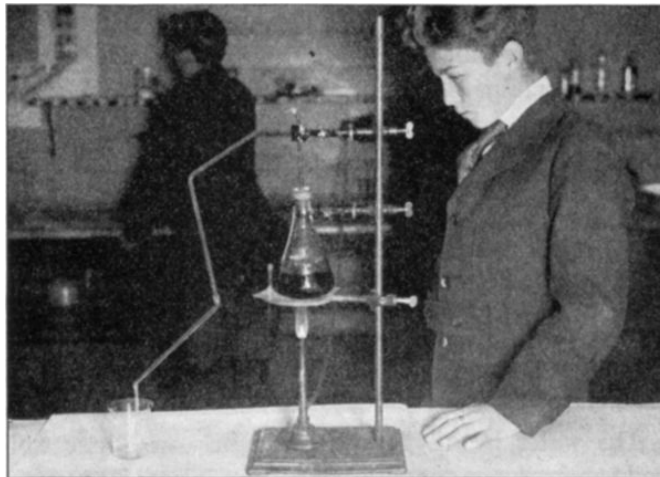

FIG. 55. By distillation clear alcohol can be separated from the water and red ink with which it was mixed.

[pg 114]

Now pour this mixture into a flask. Pass the end of the long bent glass rod (the "worm") through a one-hole rubber stopper that will fit the flask (Fig. 55). Put the flask on a ring stand and, holding it steady, fasten the neck of the flask with a clamp that is attached to the stand. Put the stopper with the worm attached into the flask, and support the worm with another clamp. Put a dry cup or beaker under the lower end of the worm. Set a lighted burner under the flask. When the mixture in the flask begins to boil, turn the flame down so that the liquid will just barely boil; if it boils violently, part of the liquid splashes up into the lower end of the worm.

As the vapor rises from the mixture and goes into the worm, it cools and condenses. When several drops have gone down into the cup, try lighting them. What is it that has boiled and then condensed: the water, the alcohol, or the blueing? Or is it a mixture of them?

Alcohol is really made in this way, only it is already mixed in the water in which the grains fermented and from which people then distil it. Gasoline and kerosene are distilled from petroleum; there is a whole series of substances that come from the crude oil, one after the other, according to their boiling points, and what is left is the foundation for a number of products, including paraffine and vaseline.

Experiment 40. Put some dry, fused calcium chlorid on a saucer and set it on the plate of the air pump. This is to absorb the moisture when you do the experiment. (This calcium chlorid is *not* the same as the chlorid of lime which you buy for bleaching or disinfecting.) Fill a flask or beaker half full of water and bring it to a boil over a Bunsen burner. Quickly set the flask on the plate of the air pump. The water will stop boiling, of course. Cover the flask and the saucer of calcium chlorid with the bell jar immediately, and pump the air out of the jar. Watch the water.

[pg 115]

The water begins to boil again because water will boil at a lower temperature when there is less air pressure on its surface. So although the water is too cool to boil in the open air, it is still hot enough to boil when the air pressure is partially removed. It is because of this that milk is evaporated in a vacuum for canning; it is not necessary to make it so hot that it will be greatly changed by the heat, if the boiling is done in a vacuum. On a high mountain the slight air pressure lets the water boil at so low a temperature that it never becomes hot enough to cook food.

Application 30. Two college students were short of money and had to economize greatly. They got an alcohol lamp to use in cooking their own breakfasts. They planned to boil their eggs.

"Let's boil the water gently, using a low flame," one said; "we'll save alcohol."

"It would be better to boil the eggs fast and get them done quickly, so that we could put the stove out altogether," the other replied.

Which was right?

Application 31. Two girls were making candy. They put a little too much water into it.

"Let us boil the candy hard so that it will candy more quickly," said one.

"Why, you wasteful girl," said the other. "It cannot get any hotter than the boiling point anyhow, so you can't cook it any faster. Why waste gas?"

Which girl was right?

Inference Exercise

Explain the following:

161. Warm air rises.
162. The lid of a teakettle rattles.
163. Heating water makes a steam engine go.
164. When an automobile with good springs and without shock absorbers goes over a rut, the passengers do not get a jolt, but immediately afterward bounce up into the air.
165. Comets swing around close to the sun, then off again into space; how do they get away from the sun?
166. When you wish to pour canned milk out, you need two holes in the can to make it flow evenly.
167. Liquid air changes to ordinary air when it becomes even as warm as a cake of ice.
168. Skid chains tend to keep automobiles from skidding on wet pavement.
169. A warm iron and a blotter will take candle grease out of your clothes.
170. Candies like fudge and nougat become hard and dry when left standing several days open to the air.

[pg 116]

SECTION 20. *Conduction of heat and convection.*

Why does a feather comforter keep you so warm?

When you heat one end of a nail, how does the heat get through to the other end?

How does a stove make the whole room warm?

Here is a way to make heat run a race. See whether the heat that goes through an iron rod will beat the heat that goes through a glass rod, or the other way round:

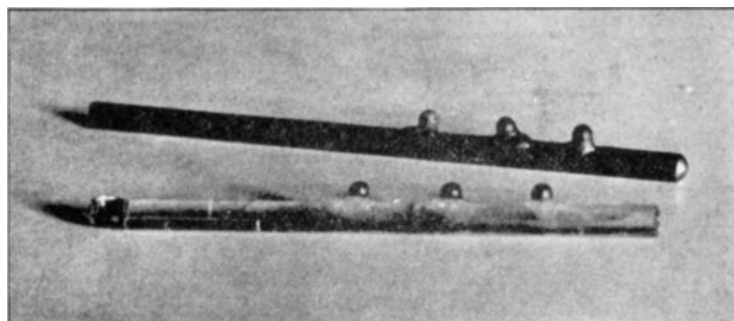

FIG. 56. The metal balls are fastened to the iron and glass rods with drops of wax.

Experiment 41. Take a solid glass rod and a solid iron rod, each about a quarter inch in diameter and about 6 inches long. With sealing wax or candle grease stick three ball bearings or pieces of lead, all the same size, to each rod, about an inch apart, beginning 2 inches from the end. Hold the rods side by side with their ends in a flame, and watch the balls fall off as the heat comes along through the rods. The heat that first melts off the balls beats.

[pg 117]



FIG. 57. Does the heat travel faster through the iron or through the glass?

[pg 118]

What really happens down among the molecules when the heat travels along the rods is that the molecules near the flame are made to move more quickly; they joggle their neighbors and make them move faster; these joggle the ones next to them, and so on down the line. Heat that travels through things in this way is called *conducted* heat. Anything like iron, that lets the heat travel through it quickly, is called a *good conductor* of heat. Anything like glass, that allows the heat to travel through it only with difficulty, is called a *poor conductor* of heat, or an *insulator* of heat.

A silver spoon used for stirring anything that is cooking gets so hot all the way up the handle that you can hardly hold it, while the handle of a wooden spoon never gets hot. Pancake turners usually have wooden handles. Metals are good conductors of heat; wood is a poor conductor.

An even more obvious example of the conducting of heat is seen in a stove lid; your fire is under it, yet the top gets so hot that you can cook on it.

When anything feels hot to the touch, it is because heat is being conducted to and through your skin to the sensitive little nerve ends just inside. But when anything feels cold, it is because heat is being conducted away from your skin into the cold object.

[pg 119]

Air carries heat by convection. One of the poorest conductors of heat is air; that is, one particle of air can hardly give any of its heat to the next particle. But particles of air move around very easily and carry their heat with them; and they can give the heat they carry with them to any solid thing they bump into. So when air can move around, the part that is next to the stove, for instance, becomes hot; this hot air is pushed up and away by cold air, and carries its heat with it. When it comes over to you in another part of the room, some of its heat is conducted to your body. When air currents—or water currents, which work the same way—carry heat from one place to another like this, we say that the heat has traveled by *convection*.

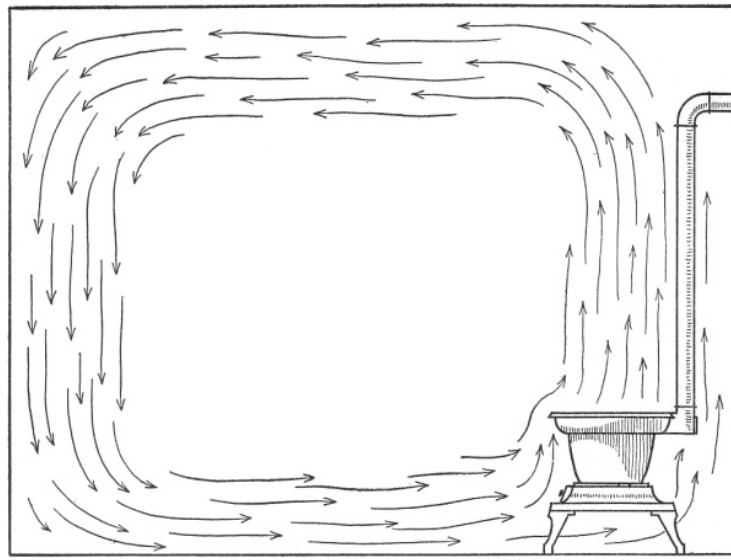

FIG. 58. Convection currents carrying the heat of the stove about the room.

Since heat is so often carried to us by convection,—by warm winds, warm air from the stove, warm ocean currents, etc.—it *seems* as if air must be a good conductor of heat. But if you shut the air up into many tiny compartments, as a bird's feathers do, or as the hair on an animal's back does, so that it cannot circulate, the passage of heat is almost completely stopped. When you use a towel or napkin to lift something hot, it is not so much the fibers of cotton which keep the heat from your hand; it is principally the very small pockets of air between the threads and even between the fibers of the threads.

[pg 120]

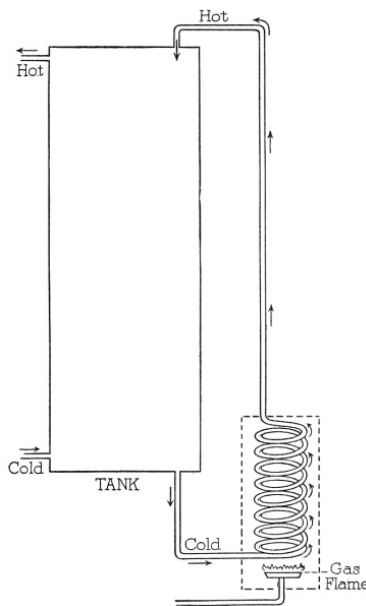

FIG. 59. Diagram of a hot-water heater. What makes the water circulate?

[pg 121]

Cold the absence of heat. Cold is merely the absence of heat; so if you keep the heat from escaping from anything warm, it cannot become cold; while if you keep the heat from reaching a cold thing it cannot become warm. A blanket is just as good for keeping ice from melting, by shutting the heat out, as it is for keeping you warm, by holding heat in.

Application 32. Explain why ice is packed in straw or sawdust; why a sweater keeps you warm.

Select from the following list the good conductors of heat from the poor conductors (insulators): glass, silver, iron, wood, straw, excelsior, copper, asbestos, steel, nickel, cloth, leather.

Inference Exercise

Explain the following:

- 171. If the axle of a wheel is not greased, it swells until it sticks fast in the hub; this is a hot box.
- 172. When you have put liquid shoe polish on your shoes, your feet become cold as it dries.
- 173. The part of an ice-cream freezer which holds the cream is usually made of metal, while that which goes outside and contains the ice and salt is usually made of wood.
- 174. The steam in a steam radiator rises from a boiler in the basement to the upper floors.
- 175. When you throw a ball, it keeps going for a while after it leaves your hand.
- 176. Clothes keep you warm, especially woolen clothes.
- 177. The Leaning Tower of Pisa does not fall over.
- 178. It is almost impossible to climb a greased pole.
- 179. Heat goes up a poker that is held in a fire.
- 180. A child can make a bicycle go rapidly without making his feet go any faster than if he were walking.

CHAPTER FIVE

RADIANT HEAT AND LIGHT

SECTION 21. *How heat gets here from the sun; why things glow when they become very hot.*

If we were to go back to our imaginary switchboard we should find a switch, between the heat and the light switches, labeled RADIATION. Suppose we turn it off:

Instantly the whole world becomes pitch dark; so does the sky. We cannot see the sun or a star; no electric lights shine; and although we can "light" a match, it gives no light. The air above the burning match is hot, and we can burn our fingers in the invisible flame, but we can see nothing whatever.

Yet the world does not get cold. If we leave the switch off for years, while the earth remains in darkness and we all live like blind people, it never gets cold. Winter and summer are alike, day and night are just the same. Gradually, after many ages, the ice and snow in the north and in the far south begin to melt as the warmth from the rest of the world is conducted to the polar regions. And the heat from the interior of the earth makes all the parts of the earth's surface warmer. Winds almost stop blowing. Ocean currents stop flowing. The land receives less rainfall, until finally everything turns to a desert; almost the only rain is on the ocean. Animals die even before the rivers dry up, for the flesh eaters are not able to see their prey, and since, without light, all green things die, the animals that live on plants soon starve. Men have to learn to live on mushrooms, which grow in the dark. The world is plunged into an eternal warm, pitch-black night.

[pg 123]



FIG. 60. It is by radiation that we get all our heat and light from the sun.

Turning off the radiation would cause all these things to happen, because it is by radiation that we get all our heat from the sun and all our light from any source. And it is by radiation that the earth loses heat into space in the night and loses still more heat into space during the winter.

We do not get our heat from the sun by conduction; we cannot, because there is nothing between us and the sun to conduct it. The earth's air, in amounts thick enough to count, goes up only a hundred miles or so. It is really just a thin sort of blanket surrounding the earth. The sun is 93,000,000 miles away. Between us and the sun there is empty space. There are no molecules to speak of in that whole vast distance. So if heat traveled only by conduction,—that is, if radiation stopped,—we should be so completely shut off from the sun that we should not know there was such a thing.

[pg 124]

But even if we filled the space between us and the sun with copper or silver, which are about the best conductors of heat in the world, it would take the heat from the sun years and years to be conducted down to us. Yet we know that the sun's heat really gets to us in a few minutes. This is because heat can travel in a very much quicker way than by conduction. It *radiates* through space, just as light does. And it can come the whole 93,000,000 miles from the sun in about 8 minutes. This is so fast that if it were going around the world instead of coming from the sun, it would go around 7-1/2 times before you could say "Jack Robinson,"—really, because it takes you at least one second to say "Jack Robinson."

We are not absolutely sure how heat gets here so fast. But what most scientists think nowadays is that there is a sort of invisible rigid stuff, not made of molecules or of anything but just itself, called *ether*. (This ether, if there really is such a thing, is not related at all to the ether that doctors use in putting people to sleep. It just happens to have the same name.) The ether is supposed to fill all space, even the tiny spaces between molecules. The fast moving particles of the sun joggle the ether up there, and make ripples that spread out swiftly all through space. When those ripples strike our earth, they make the molecules of earth joggle, and that is heat.

The ripples that spread out from the sun are called *ether waves*.

[pg 125]

But the important and practical fact to know is that there is a kind of heat, called *radiant heat*, that can pass through empty space with lightning-like quickness. And when this radiant heat strikes *things*, it is partly absorbed and changed to the usual kind of heat.

This radiant heat is closely related to light. As a matter of fact, light is only the special kind of ether waves that affect our eyes. Radiant heat is invisible. The ether waves that are visible we call light. In terms of ether waves, the only difference between light and radiant heat is that the ripples in light are shorter. So it is no wonder that when we get a piece of iron hot enough, it begins to give off light; and we say it is red hot. What happens to the ether is this: As the molecules of iron go faster and faster (that is, as the iron gets hotter and hotter), they make the ripples in the ether move more frequently until they get short enough to be *light* instead of radiant heat. Objects give off radiant heat without showing it at all; the warmth that you feel just below a hot flatiron is mainly radiant heat.

When anything becomes hot enough to glow, we say it is *incandescent*. That is why electric lamps are called *incandescent lamps*. The fine wires—called the *filament*—in the lamp get so hot when the electricity flows through them that they glow or become incandescent, throwing off light and radiant heat.

It is the absorbing of the radiant heat by your hand that makes you feel the heat the instant you turn an electric lamp on. Try this experiment:

Experiment 42. Turn on an incandescent lamp that is cold. Feel it with your hand a second, then turn it off at once. Is the glass hot? (The lamp you use should be an ordinary 25, 40, or 60 watt vacuum lamp.)

[pg 126]

The radiant heat from the incandescent filament in the lamp passed right out through the vacuum of the lamp, and much of it went on through the glass to your hand. You already know what a poor conductor of heat glass is; yet it lets a great deal of radiant heat pass through it, just as it does light. As soon as the lamp stops glowing, the heat stops coming; the glass is not made hot and you no longer feel any heat. In one way the electric filament shining through a vacuum is exactly like the sun shining through empty space: the heat from both comes to us by radiation.

If a lamp glows for a long time, however, the glass really does become hot. That is partly because there is not a perfect vacuum within it (there is a little gas inside that carries the heat to the glass by convection), and it is partly because the glass does not let quite all of the radiant heat and light go through it, but absorbs some and changes it to the regular conducted heat.

One practical use that is made of a knowledge of the difference between radiant and conducted heat is in the manufacture of thermos bottles.

Experiment 43. Take a thermos bottle apart. Examine it carefully. If it is the standard thermos bottle, with the name "thermos" on it, you will find that it is made of two layers of glass with a vacuum between them. The vacuum keeps any *conducted* heat from getting out of the bottle or into it. But, as you know, *radiant* heat can flash right through a vacuum. So to keep it from doing this the glass is silvered, making a mirror out of it. Just as a mirror sends light back to where it comes from, it sends practically all radiant heat back to where it comes from. Heat, therefore, cannot get into the thermos bottle or out of it either by radiation or conduction. And that is why thermos bottles will keep things very hot or ice-cold for such a long time.

[pg 127]



FIG. 61. How a thermos bottle is made. Notice the double layer of glass in the broken one.

Fill the thermos bottle with boiling water, stopper it, and put it aside till the next day. See whether the water is still hot.

If we could make the vacuum perfect, and surround all parts of the bottle, even the mouth, with the perfect vacuum, and if the mirror were perfect, things put into a thermos bottle would stay boiling hot or icy cold forever and ever.

Why it is cool at night and cold in winter. It is the radiation of heat from the earth into space that makes the earth cooler at night and cold in winter. Much of the heat that the earth absorbs from the sun in the daytime radiates away at night. And since it keeps on radiating away until the sun brings us more heat the next day, it is colder just before dawn than at midnight, more heat having radiated into space.

[pg 128]

For the same reason it is colder in January and February than in December. It is in December that the days are shortest and the sun shines on us at the greatest slant, so that we get the least heat from it; but we still have left some of the heat that was absorbed in the summer. And we keep losing this heat by radiation faster than we get heat from the sun, until almost spring.

Application 33. Distinguish between radiant and conducted heat in each of the following examples:

(a) The sun warms a room through the window. (b) A room is cooler with the shades down than up, when the sun shines on the window. (c) But even with the shades down a room on the sunny side of the house is warmer than a room on the shady side. (d) When a mirror is facing the sun, the back gets hot. (e) If you put your hand in front of a mirror held in the sun, the mirror reflects heat to your hand. (f) If you put a plate on a steam radiator, the top of the plate gradually becomes hot. (g) If anything very hot or cold touches a gold or amalgam filling of a sensitive tooth, you feel it decidedly. (h) The handle of your soup spoon becomes hot when the bowl of it is in the hot soup. (i) The moon is now very cold, although it probably was once very hot.

Inference Exercise

Explain the following:

181. Trees bend in the wind, then straighten up again. Why do they straighten up?

182. A cloth saturated with kerosene and placed in the bottom of a clock will oil the clockworks above it.

183. In cold weather the doorknob *inside* the front door is cold.

184. It is cool in the shade.

185. Clothes get hot when you iron them.

186. Potatoes fried in deep fat cook more quickly than those boiled in water.

187. If you hold your hand near a vacuum electric lamp globe that is glowing, some of the heat will go out to your hand at once.

188. Rubbing silver with fine powder polishes it.

189. A mosquito can suck your blood.

190. A hot-water tank becomes hot at the top first, then gradually heats downward. When you light the gas under an ordinary hot-water heater, the hot water circulates to the top of the boiler, while the cold water from the boiler pushes into the bottom part of the heater, as shown in Figure 59. What causes this circulation?

[pg 129]

SECTION 22. Reflection.

How is it that you can see yourself in a mirror?

What makes a ring around the moon?

Why can we see clouds and not the air?

Why is a pair of new shoes or anything smooth usually shiny?

If we turn off a switch labeled REFLECTION OF LIGHT on our imaginary switchboard, we think at first that we have accidentally turned off RADIATION again, for once more everything instantly becomes dark around us. We cannot see our hands in front of our faces. Although it is the middle of the day, the sky is jet black. But this time we see bright stars shining in it. And among them is the sun, shining as brightly as ever and dazzling our eyes when we look at it. But its light does no good. When we look down from the sky toward the earth, everything is so black that we should think we were blind if we had not just seen the stars and sun.

Groping our way along to an electric lamp, we turn it on. It shines brightly, but it does not make anything around it light; everything stays absolutely invisible. It is as if all things in the world except the lights had put on some sort of magic invisible caps.

We can strike a match and see its flame. We can see a fire on the hearth. We may feel around for the invisible poker, and when we find it, we may put it in the fire. When it becomes hot enough, it will glow red and become visible. We can make a match head glow by rubbing it on a wet finger. We can even see a firefly, if one comes around. But only those things which are glowing of themselves, like flames, and red-hot pokers, and fireflies, will be visible.

The reason why practically everything would be invisible if there were no reflection of light is this: When you look at anything, as a man, for instance, what you really see is the light that hits him and bounces back (reflects) into your eyes. Suppose you go into a dark room and turn on an electric light. Instantly ripples of light flash out from the lamp in every direction. As soon as they strike the object you are looking at, they reflect (bounce back) from it to your eyes. When light strikes your eyes, you see.

Of course, when you look at an electric lamp, or a star, or the sun, or anything that is incandescent (so hot that it shines by its own light), you can see it, whether reflection exists or not. But most things you look at do not shine by their own light. This book that you are reading simply reflects the light in the room to your eyes; it would not give any light in a dark room. The paper reflects a good deal of light that strikes it, so it looks very light; the print reflects practically none of the light that strikes it, so it looks dark, or black, just as a keyhole looks black because it does not reflect any light to your eyes. But without reflection, the book would be entirely invisible. The only kind of print you could read if there were no reflection would be the electric signs made out of incandescent lamps arranged to form letters.

What the ring around the moon is; what sunbeams are. The reason you sometimes see a ring around the moon is that some of the moonlight reflects from tiny droplets of water in the air, making them visible. In the same way, the dust in the air of a room becomes visible when the sun shines through it and is reflected by each speck of dust; we call it a *sunbeam*. But we are not really looking directly at the sunlight; we are seeing the part of the sunlight that is reflected by the dust specks.

Have you ever noticed that when you stand a little to one side of a mirror where you cannot see your own image in it, you can sometimes see that of another person clearly, while he cannot see his own image but can see yours? It is easy to understand this by comparing the reflection of the light from your face to his eye and from his face to your eye, to the bouncing of a ball from one person to another. Suppose you and a friend are standing a little way apart on sandy ground where you cannot bounce a ball, but that between you there is a plank. If each of you is standing well away from the plank, neither one of you can possibly bounce the ball on it in such a way that he can catch it himself. Yet you can easily bounce it to your friend and he can bounce it to you.

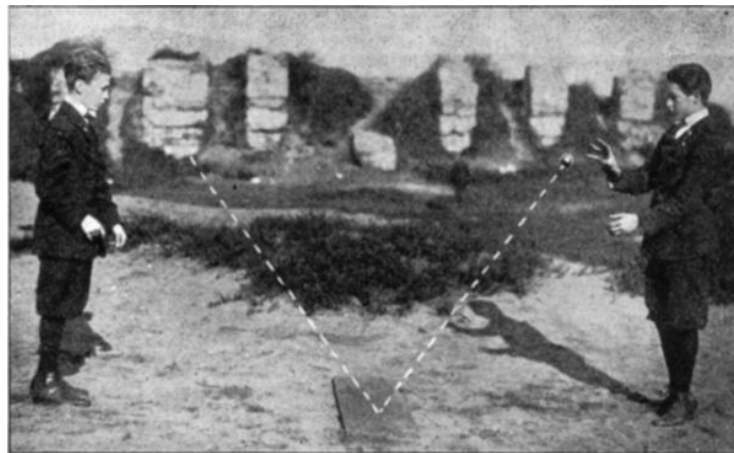

FIG. 62. The ball bounces from one boy to the other, but it does not return to the one who threw it.

The mirror is like that plank; it is something that will reflect (bounce) the light directly. The light from your face goes into the mirror, just as you may throw the ball against the plank, and the light is reflected to your friend just as the ball is bounced to him; so he sees your image in the mirror. If he can see you, you can see him, just as when you bounce the ball to him he can bounce it to you. But you may be unable to see yourself, just as you may be unable to bounce the ball on the plank so that you yourself can catch it.

In other words, when light strikes against something it bounces away, just as a rubber ball bounces from a smooth surface. If you throw a ball straight down, it comes straight up; if light shines straight down on a flat, smooth surface, it reflects straight up. If you throw a ball down at a slant, it bounces up at the same slant in the opposite direction; if light strikes a smooth surface

at a slant, it reflects at the same slant in the opposite direction.

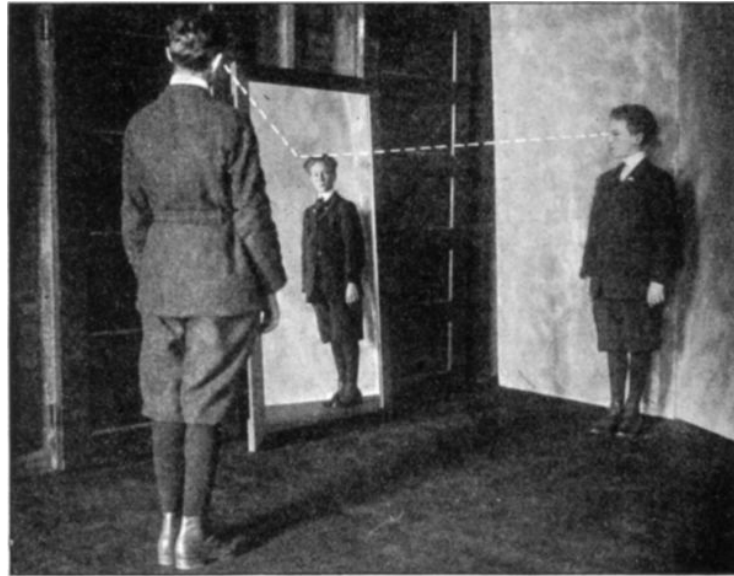

FIG. 63. In the same way, the light bounces (reflects) from one boy to the other. It does not return to the point from which it started and neither boy can see himself.

But to reflect light directly and to give a clear image, the surface the light strikes *must* be extremely smooth, just as a tennis court must be fairly smooth to make a tennis ball rebound accurately. Any surface that is smooth enough will act like a mirror, although naturally, if it lets most of the light go through, it will not reflect as well as if it sends all the light back. A pane of glass is very smooth, and you can see yourself in it, especially if there is not much light coming through the glass from the other side to mix up with your reflection. But if the pane of glass is silvered so that no light can get through, you have a real mirror; most of the light that leaves your face is reflected to your eyes again.

[pg 134]

Why smooth or wet things are shiny. When a surface is very smooth, we say it is shiny or glossy. Even black shoes, if they are polished, become smooth enough to reflect much of the light that strikes them; of course the parts where the light is being reflected do not look black but white, as any one who has tried to paint or draw a picture of polished shoes knows. Anything wet is likely to be shiny, because the surface of water is usually smooth enough to reflect light rather directly.

If a surface is uneven, like a pool with ripples on it, the light reflects unevenly, and you see a distorted image; your face seems to be rippling and moving in the water.

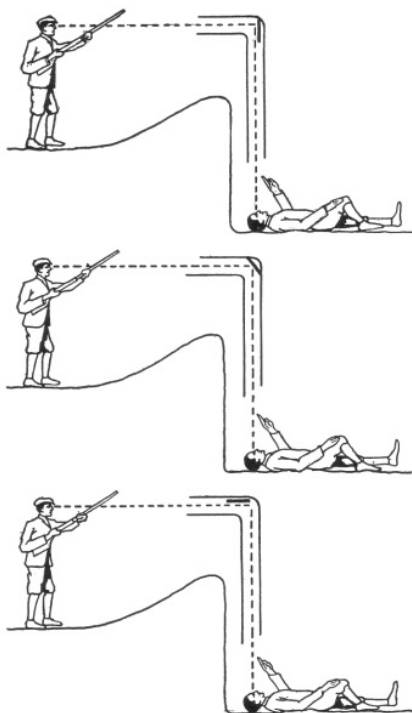

[pg 135]

FIG. 64. How should the mirror be placed?

Application 34. Some boys were playing war and were in a ditch that they called a trench. They wanted to make a simple periscope so that they could look out of the ditch at the "enemy" without being in danger. They had an old stovepipe and a mirror. Practically all of them agreed that if the mirror were fixed in the top of the stovepipe and if they looked up through the bottom, they would be able to see over the side of the ditch. But they had an argument as to how the mirror should be placed. Each drew a diagram to show how he thought the mirror should be arranged, using dotted lines to show how the light would come from the enemy to their eyes. Three of the diagrams are shown in Figure 64.

The boy who drew the first said: "If you want to see the enemy, the mirror's got to face him. Then it will reflect the light down to your eyes."

The boy who drew the second said: "No, the light would just go back to him again. The mirror must slant so that the light that strikes it at a slant will be reflected to your eye at the same slant."

"How could it get to your eye at all," the third boy said, "if the mirror didn't face you? You've got to have the mirror reflect right down toward your face. Then all the light that strikes it will come down to you."

Inference Exercise

Explain the following:

- 191. Your hands do not get wet when you put them into mercury.
- 192. When beating hot candy, we sometimes put it in a pan of water.
- 193. Electric stoves frequently have bright reflectors.
- 194. We put ice in the *top* of a refrigerator.
- 195. You can jack up the back part of an automobile when you could not possibly lift it up.
- 196. The sun shines up into your face and sunburns you when you are on the water.
- 197. People in the tropics dress largely in white.
- 198. Menthol rubbed into your skin makes it feel very cold afterward.
- 199. We feel the heat of the sun almost as soon as the sun rises.
- 200. You can shoot a stone far and hard with a sling shot.

[pg 136]

SECTION 23. *The bending of light: Refraction.*

How do glasses help your eyes?

On a hot day, how is it that you see "heat waves" rising from the street?

What makes the stars twinkle?

Light usually travels in straight lines. If the light from an object comes from straight in front of you, you know that the object is straight in front of you. But you can bend light so that it seems to come from a different place, thus making things seem to be where they are not.

Experiment 44. Hold a triangular glass prism vertically (straight up and down) in front of one eye, closing the other eye. Look through the prism, turning it or your head around until you see a chair through it. Watch only the chair through the prism. When you are sure you know just where it is, try to sit down in it.

Now look for a pencil or a piece of chalk through the prism, in the same way. When you think you know where it is, try to pick it up.

The reason the chalk and chair seem to be where they are not is that the prism bends the light that comes from them and makes the light seem to come from somewhere else.

[pg 137]

As you already know, when you look at a chair you see the light that reflects from it. You judge where the chair is by the direction from which the light is coming when it reaches your eye. But if the light is bent on its way, so that it comes to your eye as it ordinarily comes from an object off to one side, naturally you think the thing you are looking at is off to one side. Maybe the diagram (Fig. 65) will make this clearer.

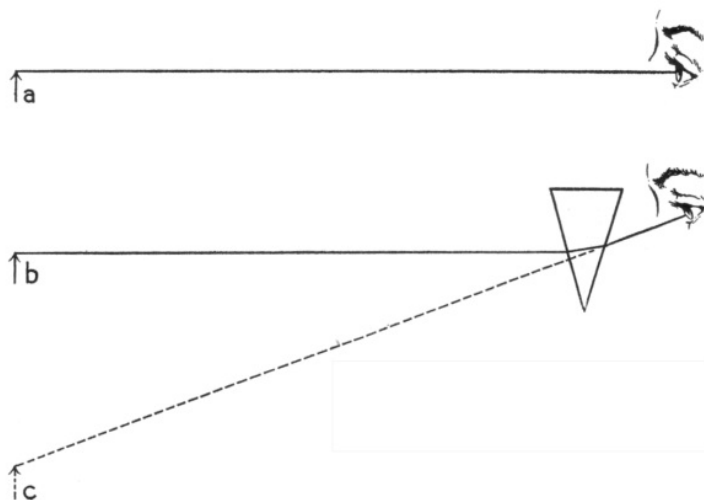

FIG. 65. In passing through the prism the light is bent so that an object at *b* appears to be at *c*.

Here in *a* is an object the same height as the eye. The light comes straight to the eye, and one knows that the object is level with the eye. In *b* the object is in the same position as in *a*, but the prism bends the light so that it strikes the eye with an upward slant. So the person thinks the object is below the eye at *c*.

Here is another experiment with bending light:

Experiment 45. Fill a china cup with water. Put a pencil in it, letting the pencil rest at a slant from left to right. Lower your head until it is almost level with the surface of the water. How does the pencil look?

[pg 138]

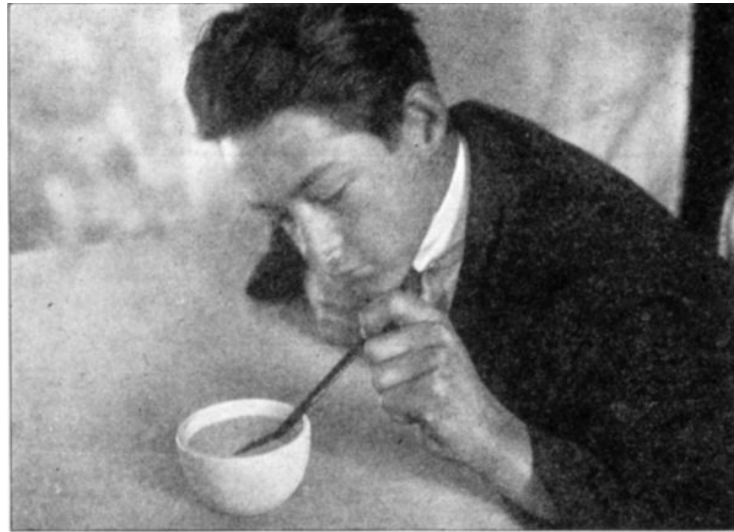

FIG. 66. The pencil is not bent, but the light that comes from it is.

The reason the pencil looks bent is because the light from the part of it under the water is bent when it passes from the water into the air on its way to your eye; so the slant at which it comes to your eye is the same slant at which it ordinarily would come from a bent pencil.

Experiment 46. Fill a glass with water. Put the pencil into it in the same way you put it in the cup in the previous experiment, letting the pencil slant from left to right. Lower your head this time until it is on a level with the water in the glass, and look through the glass and water at the pencil. Notice what happens where the pencil goes into the water.

[pg 139]

What you see is explained in the same way as are the things that took place in the other experiments in refraction, or bending of light. The light from the part of the pencil above the water comes straight to your eye, of course; so you see it just as it is. But the light from the part of the pencil in the water is bent when it comes out of the water into the air on its way to your eye. This makes it come to your eye from a different direction and makes the lower part of the pencil seem to be in a place to one side of the place where it *really* is. The pencil, therefore, looks broken.



FIG. 67. The bending of the light by the water in the glass causes the pencil to look broken.

Whenever light passes first through something dense like water or glass, and then through

something rare or thin like air, it is bent one way; whenever it passes from a rare medium into a dense one, it is bent the other way. Light passing from a fish to your eye is bent one way; light passing from you to the fish's eye is bent the other way, but the main point is that it is bent. And when light is bent before reaching your eyes it usually makes things seem to be where they are not.

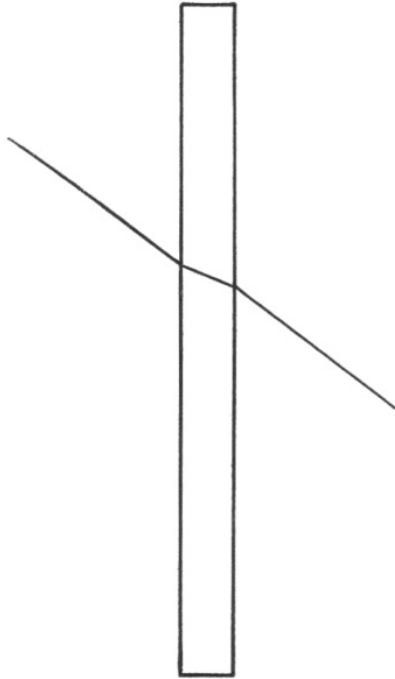

FIG. 68. The light is bent when it enters a window pane and is bent again in the opposite direction when it leaves it.

If light goes through a perfectly smooth, flat pane of glass, it is bent one way when it goes into the glass and back the other way when it comes out; so it seems to be perfectly straight and we see things practically as they are through a good window. But if the window glass has flaws in it, so that some parts are a little thicker than others, the uneven parts act like prisms and bend the light to one side. This makes anything we look at through a poor window seem bent out of shape. Of course the things are not bent any more than your pencil in the water was bent, but they look misshapen because the light from them is bent; the reflected light is all we see of things anyway.

The air itself is uneven in a way. The parts of the air that are warm, as you already know, are thinner and more expanded than are the cold parts. So light going from cold air into warm or from warm air into cold, will be bent. And this is why you see what are called "heat waves" above a stove or rising from a hot beach or sidewalk. Really these are just waves of hot air rising, and they bend the light that comes through them so as to give everything behind them a wavy appearance.

Stars twinkle for much the same reason. As the starlight comes down through the cold air and then through the warm air it is bent, and the star seems to be to one side of where it really is; but the air does not stand still,—sometimes it bends the light more and sometimes less. So the star seems to move a little back and forth. And this is what we call "twinkling." Really it is the bending of light.

Application 35. Explain why an unevenness in your eye will keep you from seeing clearly; how glasses can help this; why good mirrors are made from plate glass, which is very smooth, instead of from the cheaper and more uneven window glass; why fishes in a glass tank appear to be where they are not.

Inference Exercise

Explain the following:

201. The fire in the open fireplace ventilates a room well by making air go up the chimney.
202. A drop of water glistens in the sun.
203. Dust goes up to the ceiling and clings there.
204. When you look at a person under moving water, his face seems distorted.
205. You sit in the sun to dry your hair.
206. Paste becomes hard and unfit for use when left open to the air.
207. In laundries clothes are partly dried by whirling them in perforated cylinders.
208. Circus balloons are filled by building a big fire under them.
209. Unevenness in a window pane makes telephone wires seen through it look crooked and bent.
210. You can see the image of a star even in a shallow puddle.

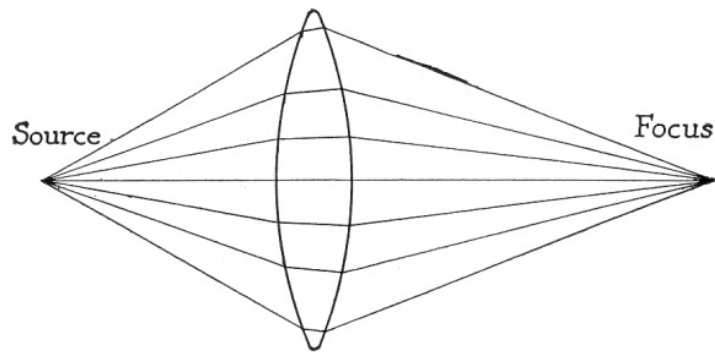

FIG. 69. When the light from one point goes through the lens, it is bent and comes together at another point called the focus.

SECTION 24. *Focus.*

How can you take pictures with a camera?

What causes the picture in the camera to be inverted?

Why is a magnifying glass able to set things on fire when you let the sun shine through it?

In your eye, right back of the pupil, there is a flattened ball, as clear as glass, called the *lens*. If the lens were left out of your eye, you never could see anything except blurs of light and shadow. If you looked at the sun it would dazzle you practically as much as it does now. However, you would not see a round sun, but only a blaze of light. You could tell night from day as well as any one, and you could tell when you stepped into the shade. If some one stepped between you and the light, you would know that some one was between you and the light or that a cloud had passed over the sun,—you could not be quite sure which. In short, you could tell all degrees of light and dark apart nearly as well as you can now, but you could not see the form of anything.

[pg 143]

In the front of a camera there is a flattened glass ball called the *lens*. If you were to remove it, the camera would not take any pictures; it would take a blur of light and shade and nothing more.

In front of a moving-picture machine there is a large lens, a piece of glass rounded out toward the middle and thinner toward the edges. If you were to take that lens off while the machine was throwing the motion pictures on the screen, you would have a flicker of light and shade, but no picture.

It is the lens that forms the pictures in your eye, on a photographic plate or film, and on a moving-picture screen. And a lens is usually just a piece of glass or something glassy, rounded out in such a way as to make all the spreading light that reaches it from one point come together in another point, as shown in Figure 69.

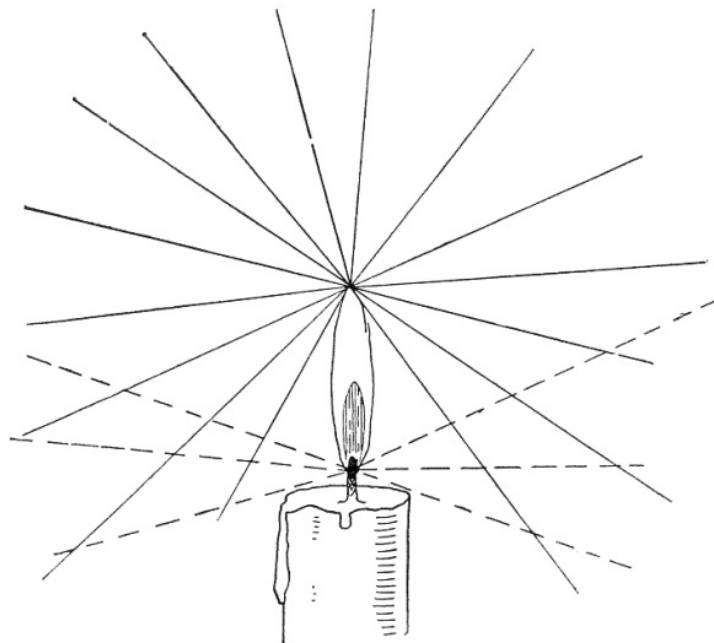

FIG. 70. The light from each point of the candle flame goes out in all directions.

As you know, when light goes out from anything, as from a candle flame or an incandescent lamp, or from the sun, it goes in all directions. If the light from the point of a candle flame goes in all directions, and if the light from the base of the flame also goes in all directions, the light from the point will get all mixed up with the light from the base, as shown in Figure 70. Naturally, if the light from the point of the candle flame is mixed up with the light from the base and the beams are all crisscross, you will not get a clear picture of the flame.

[pg 144]



FIG. 71. The reading glass is a lens which focuses the light from the candle flame and forms an image.

Experiment 47. Fasten a piece of paper against a wall and place a lighted candle about 4 feet in front of it. Look at the paper. Is there any picture of the candle flame on it? Now hold a magnifying glass (reading glass) near the candle, between the candle and the paper, so that the light will shine through the lens on to the paper. (The magnifying glass is a lens.) Move the lens slowly toward the paper until you get a clear picture of the candle flame. Is it right side up or upside down?

[pg 145]

The lens has brought the light from the candle flame to a *focus*; all the light that goes through the lens from one point of the flame has been brought together at another point (Fig. 72). In the diagram you see all the light from the *point* of the candle flame spreading out in every direction. But the part that goes through the lens is brought together at one point, called the focus. Of course the same thing happens to the light from the base of the candle flame (Fig. 73). Just as before, all the light from the base of the flame is brought to a focus. The light spreads out until it reaches the lens. Then the lens bends it together again until it comes to a point.

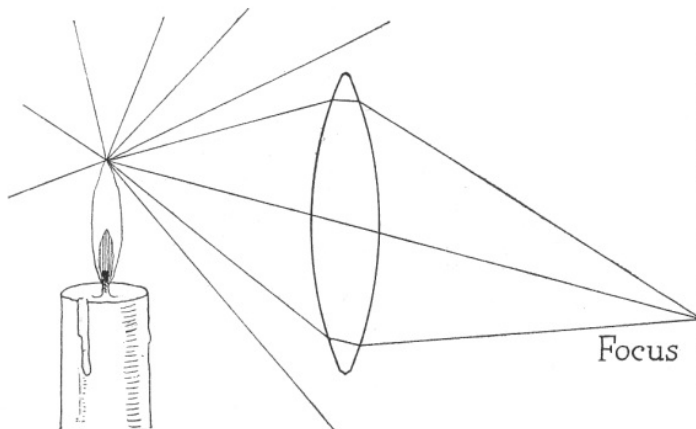

FIG. 72. The light from the tip of the candle flame is focused at one point.

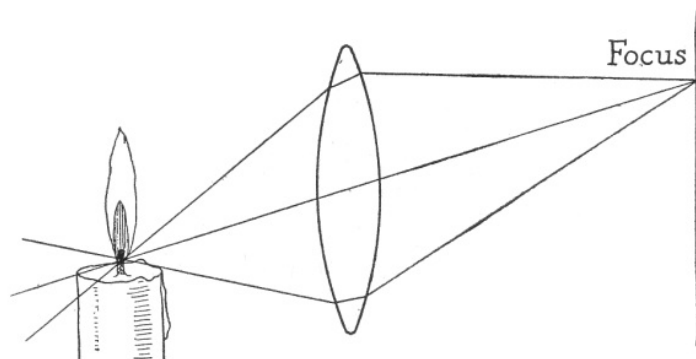

FIG. 73. And the light from the base of the flame is focused at another point.

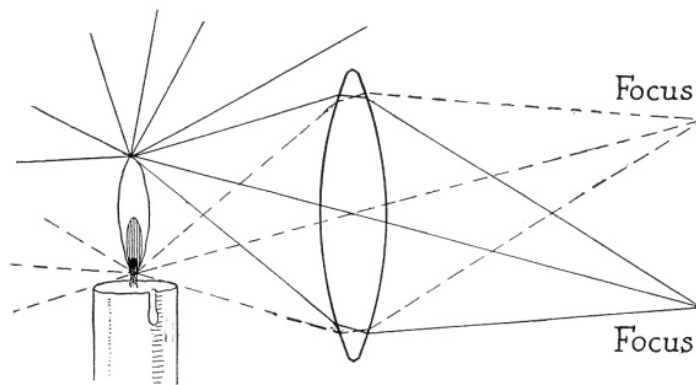

FIG. 74. The light from the tip and base (and from every other point) of the flame is, of course, focused at the same time. In this way an image of the flame is formed.

But of course the light from the base of the flame is focused at the same time as the light from the point; so what really happens is that which is illustrated in Figure 74. In this diagram, we have drawn unbroken lines to show the light from the point of the candle flame and dotted lines to show the light from the base of the flame. This is so that you can follow the light from each part and see where it goes. Compare this diagram with the one where the light is shown all crisscrossed (Fig. 70), and you will see why the lens makes an image, while you have no image without it.

By looking at the last diagram (Fig. 74) you can also see how the image happens to be upside down.

Experiment 48. Set up the candle and piece of paper as you did for the last experiment, but move the magnifying glass back and forth between the paper and the candle. Notice that there is one place where the image of the candle is very clear. Does the image become clearer or less clear if you move the lens closer to the candle? if you move it farther from the candle?

The explanation is this: After the light comes together into a point, it spreads out again beyond the point, as shown in Figure 75. So if you hold the lens in such a way that the light comes to a focus before it reaches the paper, the paper will catch the spreading light and you will get a blur instead of a sharp image. It is as shown in Figure 76.

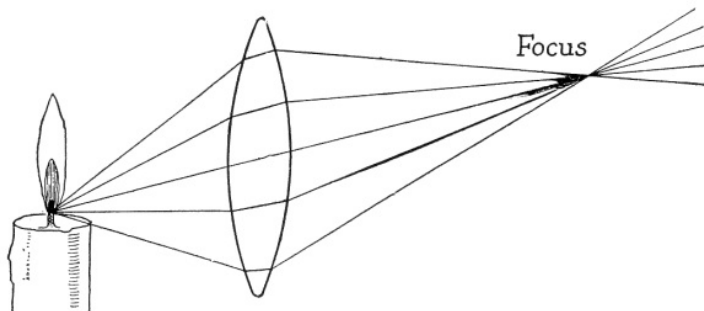

FIG. 75. The light spreads out again beyond the focus.

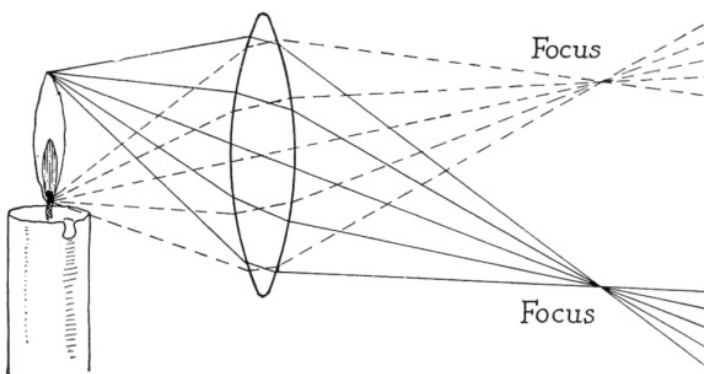

FIG. 76. So if the light comes to a focus before it reaches the paper, the image will be blurred.

On the other hand, if you hold your lens in such a way that the light has not yet come to a focus when it reaches the paper, naturally you again have a blur of light instead of a point, and the image is not sharp and definite (Fig. 77).

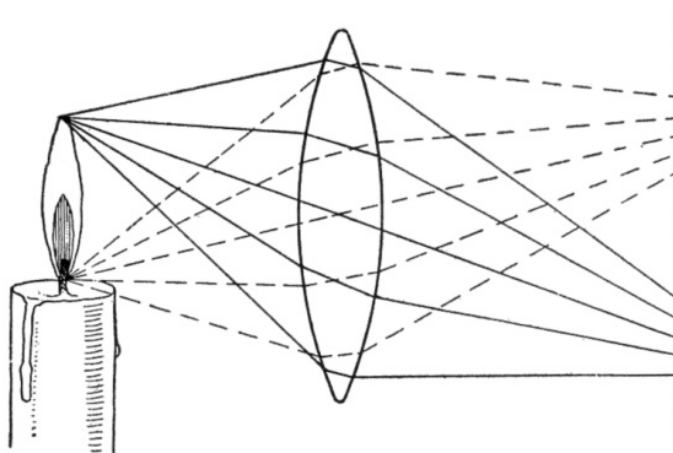

FIG. 77. Or if the light reaches the paper before it comes to a focus, the image will be blurred.

And that is why good cameras have the front part, in which the lens is set, adjustable; you can move the lens back and forth until a sharp image is formed on the plate. Motion-picture machines and stereopticons likewise have lenses that can be moved forward and back until they form a sharp focus on the screen. Even the lens in your eye has muscles that make it flatter and rounder, so that it can make a clear image on the sensitive retina in the back of your eye. The lens in the eyes of elderly people often becomes too hard to be regulated in this way, and so they have to wear one kind of glasses to see things near them clearly and another kind to see things far away.

The kind of lens we have been talking about is the *convex* lens. "Convex" means bulging out in the middle. There are other kinds of lenses, some flat on one side and bulging out on the other, some hollowed out toward the middle instead of bulging, and so on. But the only lens that most people make much use of (except opticians) is the convex lens that bulges out toward the center. The convex lens makes a clear image and it is the only kind of lens that will do this.

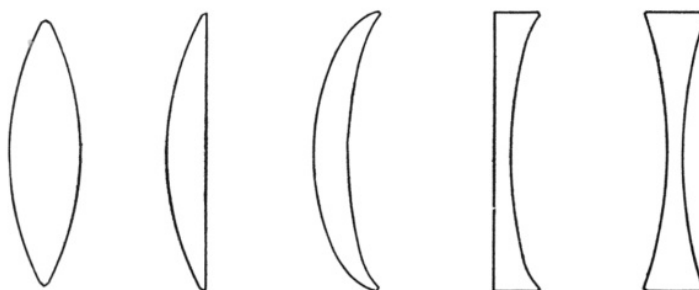

FIG. 78. Lenses of different kinds.

Why you can set fire to paper with a magnifying glass. A convex lens brings light to a focus, and it also brings radiant heat to a focus. And that is why you can set fire to things by holding a convex lens in the sunlight so that the light and heat are focused on something that will burn. All the sun's radiant heat that strikes the lens is brought practically to one point, and all the light which is absorbed at this point is changed to heat. When so much heat is concentrated at one point, that point becomes hot enough to catch fire.

Application 36. Explain why there is a lens in a moving-picture machine; why a convex lens will burn your hand if you hold it between your hand and the sun; why the front of a good camera is made so that it can be moved closer to the plate or farther away from it, according to the distance of the object you are photographing; why there is a lens in your eye.

Inference Exercise

Explain the following:

211. Cut glass ware sparkles.

212. An unpainted floor becomes much dirtier and is harder to clean than a painted one.

213. If you sprinkle wet tea leaves on a rug before sweeping it, not so much dust will be raised.
214. Food leaves a spoon when the spoon is struck sharply upon the edge of a stewpan.
215. An image is formed on the photographic plate of a camera.
216. Ripples in a pool distort the image seen in it.
217. Cream rises to the top of a bottle of milk.
218. Your eyes have to adjust themselves differently to see things near by and to see things at a distance.
219. A vacuum cleaner does not wear out a carpet nearly as quickly as a broom or a carpet sweeper does.
220. You can see a sunbeam in a dusty room.

SECTION 25. *Magnification.*

Why is it that things look bigger under a magnifying glass than under other kinds of glass?

How does a telescope show you the moon, stars, and planets?

How does a microscope make things look larger?

Everybody knows, of course, that a convex lens in the right position makes things look larger. People use convex lenses to make print look larger when they read, and for that reason such lenses are often called *reading glasses*. For practical purposes it is not necessary to understand how a convex lens magnifies; the important thing is the fact that it does magnify. But you may be curious to know just how a magnifying glass works.

First, you should realize that the image formed by a convex lens is not always larger than the object. Repeat Experiment 41, but this time move the lens from near the candle toward the paper, past the point where it makes its first clear image. Keep moving the lens slowly toward the paper until a second image is formed. Which image is larger than the flame? Which is smaller?

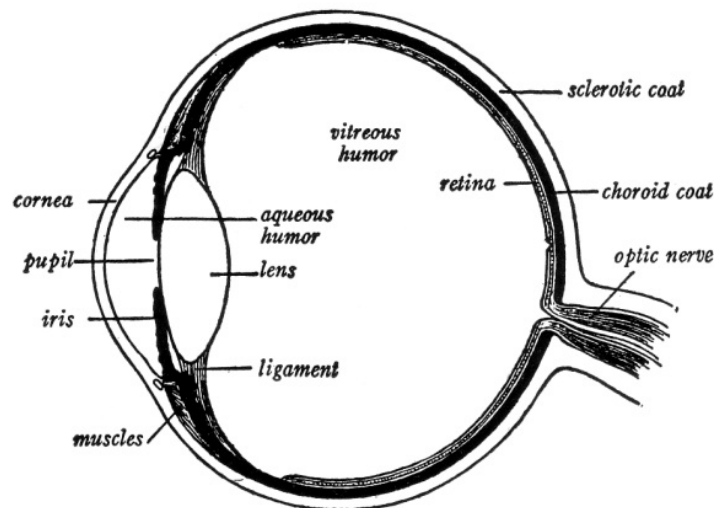

FIG. 79. A section of the eye.

The important point in this experiment is for you to see that if the lens is nearer to the image on the paper than it is to the candle, the image is smaller than the candle. That is why a photograph is usually smaller than the thing photographed; it would be impossible to take a picture of a house or a mountain if the lens in the camera gave a *magnified* image.

⁴Your eye is a small camera. It has a lens in the front; it is lined with black; and at the back there is a sensitive part on which the picture is formed. This sensitive part of the eye is called the *retina*. It is in the back part of your eyeball and is made of many very sensitive nerve endings. When the light strikes these nerve endings, it sends an impulse through the nerves to the back part of the brain; then you know that the image is formed. And, of course, since your eyeball is small and many of the things you see are large, the image on the retina must be much smaller than the object itself, and this is because the lens is so much nearer to the retina than it is to the object.

Footnote 4: The following explanation may be omitted by any children who are not

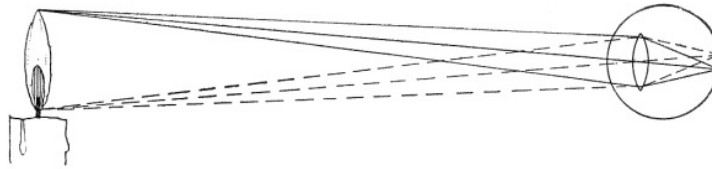

FIG. 80. How an image is formed on the retina of the eye.

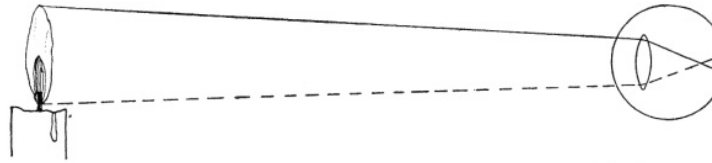

FIG. 81. A simpler diagram showing how an image is formed in the eye.

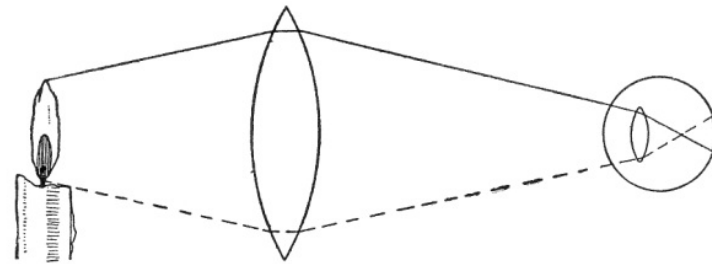

FIG. 82. A diagram showing how a reading glass causes things to look larger by making the image on the retina larger.

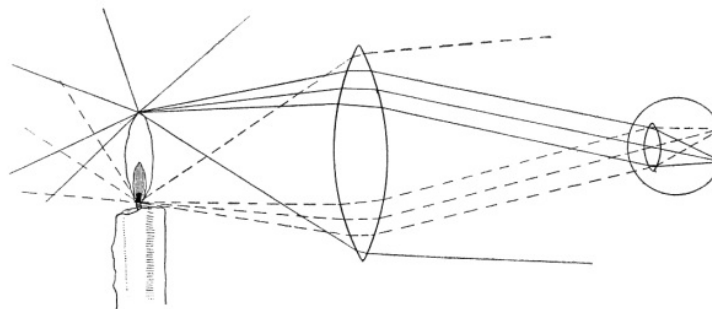

FIG. 83. Diagram showing how a reading glass enlarges the image on the retina. More lines are drawn in than in Figure 82.

You can understand magnification best by looking at Figures 80, 81, 82, and 83.

In Figure 80 there are a candle flame, the lens of an eye, and the retina on which the image is being formed.

Figure 81 is the same as Figure 80, with all the lines left out except the outside ones that go to the lens. It is shown in this way merely for the sake of simplicity. All the lines really belong in this diagram as in the first. In both diagrams the size of the image on the retina is the distance between the point where the top line touches it and the point where the bottom line touches it.

In order to make anything look larger, we must make the image on the retina larger. A magnifying glass, or convex lens, if put in the right place, will do this. In the next diagram, Figure 82, we shall include the magnifying glass, leaving out all lines except the two outside ones shown in Figure 81.

You will notice that the magnifying glass starts to bend the lines together, and that the lens in the eye bends them farther together; so they cross sooner, and the image is larger. Figure 83 shows more of the lines drawn in.

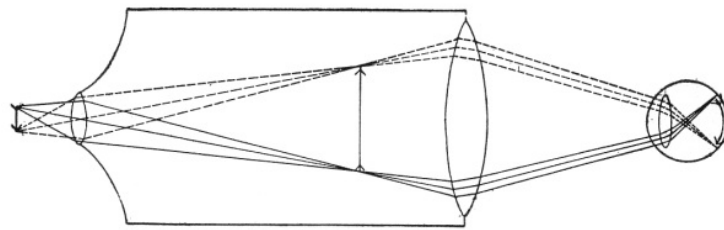

FIG. 84. Diagram of a microscope.

The two important points to notice are these: First, the magnifying glass is too close to the eye for the light to be brought to a focus before it reaches the eye; the light is bent toward a focus, but it reaches the eye before the focus is formed. The focus is formed for the first time on the retina itself. Second, the magnifying glass bends the light on its way to your eye so that the light crosses sooner in your eye and spreads out farther before it comes to a focus. This forms the larger image, as you see in the simple diagram, Figure 82.

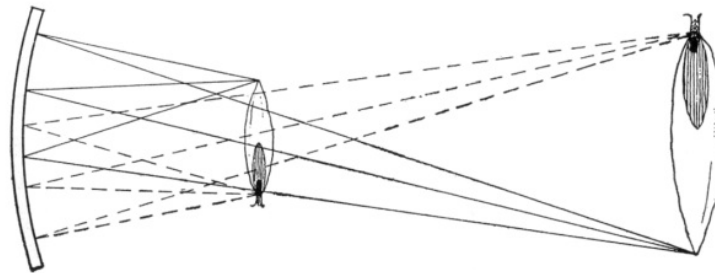

FIG. 85. This is the way a concave mirror forms a magnified image.

[pg 155]

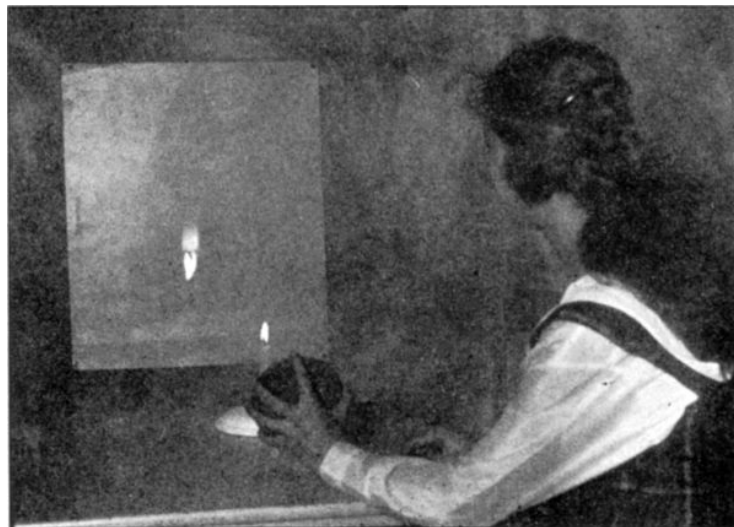

FIG. 86. The concave mirror forms an image of the burning candle.

How the microscope works. But the microscope is different. It works like this: The first lens is put very near the object which you are examining. This lens brings the light from the object to a focus and forms an image, much larger than the object itself, high up in the tube. If you held a piece of paper there you would see the image. But since there is nothing there to stop the light, it goes on up the tube, spreading as it goes. Then there is another lens which catches this light and bends it inward on its way to your eye, just as any magnifying glass does. Next the lens in the eye forms an image on the retina. The diagram (Fig. 84) will make this clearer. (A real microscope is not so simple, of course, and usually has two lenses wherever the diagram shows one.) What actually happens is that the first lens makes an image many times as big as the object; then you look at this image through a magnifying glass, so that the object is made to look very much larger than it really is. That is why you can see blood corpuscles and germs and cells through a microscope, when you cannot see them at all with your naked eye.

[pg 156]



FIG. 87. The great telescope of the Yerkes Observatory at Lake Geneva, Wisconsin.

[pg 157]

A mirror that magnifies. A convex lens is not the only thing that can magnify. A concave mirror, which is one that is hollowed out toward the middle, does the same thing. When light is reflected by such a mirror, it acts exactly as if it had gone through a convex lens (Fig. 85).

Experiment 49. Place the lighted candle and the paper about 4 feet apart, as you did in Experiment 47. Hold a concave mirror *back* of the candle (so that the candle is between the mirror and the paper); then move the mirror back, the mirror casting the reflection of the candle light on the paper, until a clear image of the candle is formed.

Look at your image in the concave mirror. Does it look larger or smaller than you?

How telescopes are made. Astronomers use convex lenses in some of their telescopes; in others, called *reflecting telescopes*, they use concave mirrors. Both do the same work, making the moon, the planets, and the sun look much larger than they otherwise would.

Application 37. Explain how a reading glass makes print look larger; how you can see germs through a microscope; what kind of mirror will magnify; what kind of lens will magnify.

Inference Exercise

Explain the following:

221. The water that forms rain comes from the ocean, yet the rain is not salty.

222. Iron glows when it is very hot.

223. You can start a fire with sunlight by holding a reading glass at the right distance above the fuel.

224. Big telescopes make it possible for us to see in detail the surface structure of the moon.

225. A room is lighter if it has white walls than if it has dark walls.

226. Iron is heated by a blacksmith before he shapes it.

[pg 158]

227. A dentist's mirror is concave; he sees your teeth enlarged in it.

228. Good penholders usually have cork or rubber tips.

229. A man's suit becomes shiny when it gets old.

230. When you look at a window from the sidewalk, you frequently see images of the houses across the street.

Why is it that on a dark day the sun cannot be seen through light clouds?

Why do not the stars come out in the daytime?

If you were on the moon, you could see the stars in the daytime. The sun would be shining even more brightly than it does here, but the sky around the sun would be pitch black, except for the stars shining out of its blackness. The reason is that there is no air on the moon to scatter the light.

Why we cannot see the stars in the daytime. Most of the sun's light that comes to the earth reaches us rather directly; that is why we can see the image of the sun. But part of the sunlight is scattered by particles of air, and that is why the whole sky is bright in the daytime. You know, of course, that the blue sky is only the air that surrounds the earth. Enough of the light is scattered around to make the sky as bright as the stars look from here; so we cannot see the stars through the sky in the daytime.

How a cloud can hide the sun without cutting off all its light. When a cloud drifts between us and the sun, we no longer see the sun; yet the earth does not become dark. The sun's light is evidently still reaching us. The cloud is made of millions of very tiny droplets of water. When the sunlight strikes the curved sides of these droplets, it is reflected at all angles according to the way it strikes, as shown in Figure 89.

[pg 159]



FIG. 88. The sunlight is scattered (diffused) by the clouds. The photograph shows in the foreground the Parliament Buildings, London, England.

Some of the light is reflected back into the sky; that is why everything becomes darker when the sun goes behind a cloud; but much of the light comes through to us, at all sorts of slants. When it comes all higgledy-piggledy and crisscross like this, no lens can put it together again; it is as hopelessly broken up as Humpty-Dumpty was. But much of the light gets here just the same; so we see it without seeing the form of the sun. Light that cannot be brought to a focus is called *scattered* or *diffused light*.

When you look through a ground-glass electric lamp, you cannot see the filament; the light passing through all the rough parts of the glass gets so scattered that you cannot bring it to a focus. Therefore, no image of the filament in the incandescent lamp can be formed on the retina of your eye.

[pg 160]

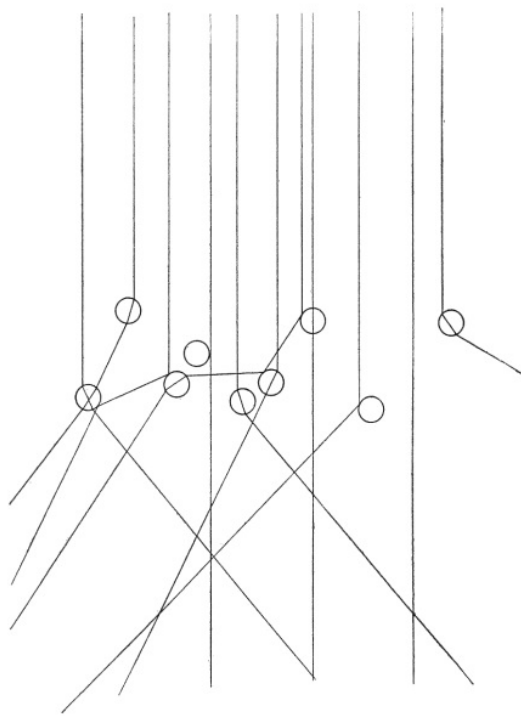

FIG. 89. How the droplets in a cloud scatter the rays of light.

[pg 161]

A piece of white paper reflects practically all the light that strikes it. Yet you cannot see yourself in a piece of ordinary white paper. The trouble is that the paper is too rough; there are too many little uneven places that reflect the light at all sorts of angles; the light is scattered and the lens in your eye cannot bring it to a focus.

Application 38. Explain why a scrim curtain will keep people from seeing into a room, but will not shut the light out; why curtains soften the light of a room; why indirect lighting (i.e. light thrown up against the ceiling and then reflected down into the room by the rough ceiling) is better for your eyes than is the old-time direct lighting.

Inference Exercise

Explain the following:

231. The alcohol formed by the yeast in making bread light is practically all gone by the time the bread is baked.
232. The oceans do not flow off the earth at the south pole.
233. Lamp globes often have frosted bottoms.
234. A damp dust cloth will take up the dust, without making it fly.
235. The stars twinkle when their light passes through the moving air currents that surround the earth.
236. Shears for cutting tin and metal have long handles and short blades.
237. A coin at the bottom of a glass of water seems raised when you look at it a little from one side.
238. You have to brace your feet to row well.
239. Light from the northern part of the sky, where the sun is not, does not make sharp shadows.
240. Pokers and lifters for stove lids often have open spiral handles.

SECTION 27. *Color.*

What makes the ocean look green in some places and blue in others?

What makes the sky blue?

What causes material to be colored?

What makes a rainbow?

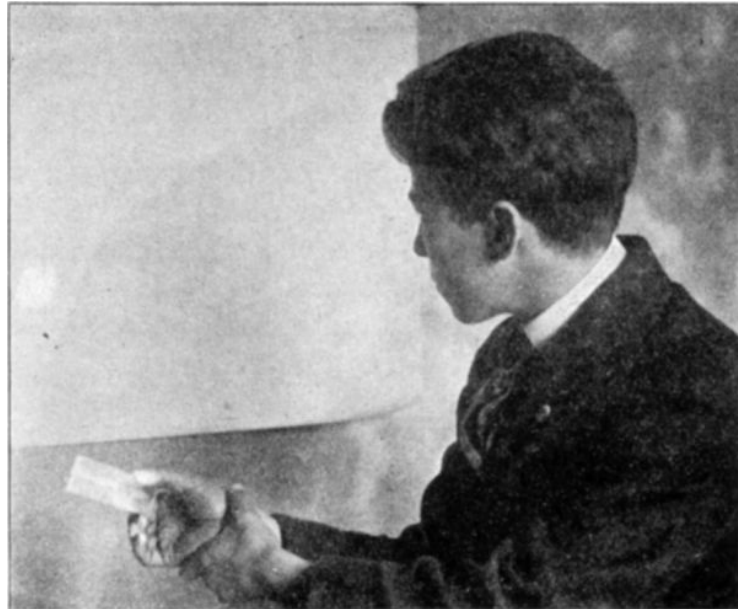

FIG. 90. Making a rainbow on the wall.

Color is merely a kind of light. We say that a sweater is red; really the sweater is not red, but the light that it reflects to our eyes is red. We speak of a piece of red glass, but the glass is not red; it is the light that it lets pass through it that is red.

White is not really a color; *all* colors put together make white. Experiments 50 and 51 will prove this.

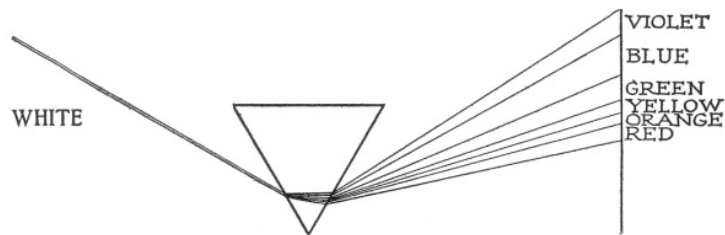

FIG. 91. The prism separates the white light into the rainbow colors.

Experiment 50. Hold a prism in the sunlight by the window and make a "rainbow" on the wall. The diagram here shown illustrates how the prism breaks up the single beam of white light into different-colored beams of light.



FIG. 92. When the wheel is rapidly whirled the colors blend to make white.

Experiment 51. Rotate the color disk on the rotator and watch it. Make it go faster

and faster until all the colors are perfectly merged. What color do you get by combining all the colors of the rainbow? If the colors on the disk were perfectly clear rainbow colors, in exactly the same proportion as in the rainbow, the whirling would give a white of dazzling purity.

Since you can break up pure white light into all the colors, and since you can combine all the colors and get pure white light, it is clear that white light is made up of all the colors.

[pg 164]

As we have already said, light is probably vibrations or waves of ether. Light made of the longest waves that we can see is red. If the waves are a little shorter, the light is orange; if they are shorter yet, it is yellow; still shorter, green; shorter still, blue; while the shortest waves that we can see are those of violet light. Black is not a color at all; it is the absence of light. We say the night is black when we cannot see anything. A deep hole looks black because practically no light is reflected up from its depths. When you "see" anything black, you really see the things around it and the parts of it that are not perfectly black. A pair of shoes, for instance, has particles of gray dust on them; or if they are very shiny they reflect part of the light that strikes them as a white high-light. But the really black part of your shoes would be invisible against an equally black background.

A black thing absorbs the light that strikes it and turns it to heat. Here is an experiment that will prove this to you:

[pg 165]

Experiment 52. (a) On a sunny day, take three bottles, all of the same size and shape, and pour water out of a pitcher or pan into each bottle. Do not run the water directly from the faucet into the bottle, because sometimes that which comes out of the faucet first is warmer or colder than that which follows; in the pitcher or pan it will all be mixed together, and so you can be sure that the water in all three bottles is of the same temperature to begin with. Wrap a piece of white cotton cloth twice around one bottle; a piece of red or green cotton cloth of the same weight twice around the second bottle, and a piece of black cotton cloth of the same weight twice around the third bottle, fastening each with a rubber band. Set all three bottles side by side in the sunlight, with 2 or 3 inches of space between them. Leave them for about an hour. Now put a thermometer into each to see which is warmest and which is least warm.



FIG. 93. Which color is warmest in the sunlight?

From which bottle has most of the light been reflected back into the air by the cloth around it? Which cloth absorbed most of the light and changed it into heat? Does the colored cloth absorb more or less light than the white one? than the black one?

(b) On a sunny day when there is snow on the ground, spread three pieces of cotton cloth, all of the same size and thickness, one white, one red or green, and one black, on top of the snow, where the sun shines on them. Watch them for a time. Under which does the snow melt first?

[pg 166]

The white cloth is white because it reflects *all* colors back at once. It therefore absorbs practically no light. But the reason the black cloth looks black is that it reflects almost none of the colors—it absorbs them all and changes them to heat. The colored cloth reflects just the red or the green light and absorbs the rest.

Maybe you will understand color better if it is explained in another way. Suppose I throw balls of all colors to you, having trained you to keep all the balls except the red ones. I throw you a blue ball; you keep it. I throw a red ball; you throw it back. I throw a green ball; you keep it. I throw a yellow ball; you keep it. I throw two balls at once, yellow and red; you keep the yellow and throw back the red. I throw a blue and yellow ball at the same time; you keep both balls.

Now suppose I change this a little. Instead of throwing balls, I shall throw lights to you. You are trained always to throw red light back to me and always to keep (absorb) all other kinds of light. I throw a blue light; you keep it, and I get no light back. I throw a red light; you throw it back to me. I throw a green light; you keep it, and I get no light back. I throw a yellow light; you keep it, and I get no light back. I throw two lights at the same time, yellow and red; you keep the yellow and throw back only the red. But yellow and red together make orange; so when I throw an orange light, you throw back the red part of it and keep the yellow.

[pg 167]

Now if we suppose that instead of throwing lights to *you* I throw them to molecules of dye which are "trained" to throw back the red lights and keep all the other kinds (absorb them and change them to heat), we can understand what the dye in a red sweater does. The dye is not really trained, of course, but for a reason which we do not entirely understand, some kinds of dye always throw back (reflect) any red that is in the light that shines on them, but they keep all other kinds of light, changing them to heat. Other dyes or coloring matter always throw back any green that is in the light that shines on them, keeping the other colors. Blue coloring matter throws back only the blue part of the light, and so on through all the colors.

So if you throw a white light, which contains all the colors, on a "red" sweater, the dye in the sweater picks out the red part of the white light and throws that back to your eyes (reflects it to you) but it keeps the rest of the colors of the white light, changing them to heat; and since only the red part of the light is reflected to your eyes, that is the only part of it that you can see; so the sweater looks red. The "green" substance (chlorophyll) in grass acts in the same way; only it throws the green part of the sunlight back to your eyes, keeping the rest; so the part of the light that reaches you from the grass is the green light, and the grass looks green.

Anything white, like a piece of paper, reflects all the light that strikes it; so if all the colors (white light) strike it, all are reflected to your eyes and the object looks white.

[pg 168]

You have looked at people under the mercury-vapor lights in photo-postal studios, have you not? The lights are long, inclined tubes which glow with a greenish-violet light. No matter how good the color of a person is in ordinary light, in that light it is ghastly.

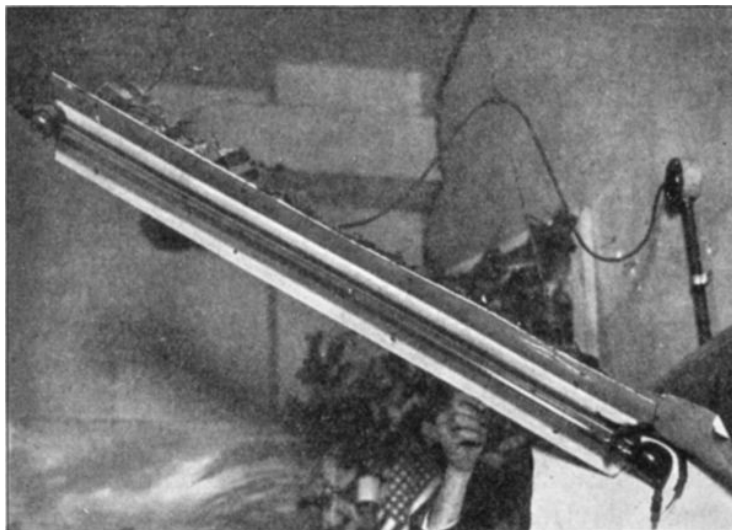

FIG. 94. A mercury-vapor lamp.

Go into the kitchen tonight, light a burner of the gas stove, turn out the light and sprinkle salt on the blue gas flame. The flame will leap up, yellow. Look at your hands, at some one's lips, at a piece of red cloth, in this light. Does anything look red?

[pg 169]

The reason why nothing looks pink or red in these two kinds of light is this: The light given by glowing salt vapor or mercury vapor has no red in it; if you tried to make a "rainbow" from it with a prism, you would find no red or orange color in it. A thing looks red when it absorbs all the parts of the light that are not red and reflects the red light to your eyes. If there is no red in the light to reflect, obviously a thing cannot look red in that light.

When you look through a piece of colored glass, the case is somewhat different. A piece of blue glass, for instance, acts as a sort of strainer. The coloring matter in it lets the blue light through it, but it holds back (absorbs) the other kinds of light. So if you look through a piece of blue glass you see everything blue; that is, only the blue part of the light from different objects can reach your eyes through this kind of glass. Anything that is transparent and colored acts in a similar

way.

Why the sky is blue. And that is why the sky looks blue. Air holds back all colors of light except blue; that is, it holds them back a little. A room full of air holds the colors back hardly at all. A few miles of air hold them back more; mountains in the distance look bluish because only the blue light from them can reach you through the air. The hundred or more miles of air above you hold back a considerable amount of the other colors of light, letting through much more of blue than of any other color. So the sky looks blue; that is, when the air scatters the sunlight above you, it is chiefly the blue parts of the sunlight that it allows to reach your eyes.

[pg 170]

Why bodies of water look green in some places and blue in others. Water acts in a similar way, but it lets the green light through instead of the blue. A little water holds back (absorbs) the other colors so slightly that you cannot notice the effect in a glass of water. But in a swimming tank full of water, or in a lake or an ocean, you can notice it decidedly when you look straight down into the water itself.

When you look at a smooth body of water at a slant on a clear day, the blue sky is reflected to you and the water looks blue instead of green. And it may even look blue when you look straight down in it if it is too deep for you to see the bottom and the sky is reflected from the surface.

Why the sky is often red at sunset. Dust lets more of red and yellow light through than of any other color, and for this reason there is much red and yellow in the sunset. Just before the sun sets, it shines through the low, dusty air. The dust filters out most of the light except the red and yellow. The red light and yellow light are reflected by the clouds (for the clouds are themselves "white"; that is, they reflect all the colors that strike them), and you have the beautiful sunset clouds. Sometimes there is a purple in the sunset, and even green. But since the air itself is blue (that is, it lets mostly blue light go through), it is easy to see how this blue can combine with the red or yellow that the dust lets through, to form purple or green.

But we could not have sunset colors or all the colors we see on earth, if it were not that the sunlight is mostly white—that it contains all colors. And that, too, is why we can have a rainbow.

[pg 171]

How rainbows are formed. You already know fairly well how a rainbow is formed, since you made an imitation of one with a prism. A rainbow appears in the sky when the sun shines through the rain; the plain white light of the sun is divided up into red, orange, yellow, green, blue, indigo, and violet. As the white light of the sun passes through the raindrops, the violet part of the light is bent more than any of the rest, the indigo part is bent not quite so much, and so on to the red, which is bent least of all. So all the colors fan out from the single beam of white light and form a band of color, which we call the rainbow.



FIG. 95. Explain why the breakers are white and the sea green or blue.

How we can tell what the sun and stars are made of. When a gas or vapor becomes hot enough to give off light (when it is incandescent), it does not give off white light but light of different colors. An experiment will let you see this for yourself.

Experiment 53. Sprinkle a little copper sulfate (bluestone) in the flame of a Bunsen burner. What color does it make the flame?

[pg 172]

Copper vapor always gives this greenish-blue light when it is heated. The photographer's mercury-vapor light gave a greenish-violet glow. When you burn salt or soda in a gas flame, you remember that you get a clear yellow light. By breaking up these lights, somewhat as you broke up the sunlight with the prism, chemists and astronomers can tell what kind of gas is glowing. The instrument they use to break up the light into its different colors is called a *spectroscope*,

and the band of colors formed is called the *spectrum*. With the spectroscope they examine the light that comes from the sun and stars and by the colors of the spectra they can tell what these far-distant bodies are made of.

Application 39. If you were going to the tropics, would it be better to wear outside clothes that were white or black?

Application 40. A dancer was to dance in a spotlight on the stage. The light was to change colors constantly. She wanted her robe to reflect each color that was thrown on it. Should she have worn a robe of red, yellow, white, green, or blue?

Application 41. If you looked through a red glass at a purple flower (purple is red mixed with blue), would the flower look red, blue, purple, black, or white?

Inference Exercise

Explain the following:

241. Mercury is separated from its ore by heating the ore so strongly that the mercury rises from it as a vapor.

242. Hothouses are built of glass.

243. A "rainbow" is sometimes seen in the spray of a garden hose.

244. Your feet become hot when your shoes are being polished.

245. Doors into offices usually have windows of ground glass or frosted glass.

[pg 173] 246. Opera glasses are of value to those sitting at a distance from the stage.

247. In order to see clearly through opera glasses, you have to adjust them.

248. It is warm inside an Eskimo's hut although it is built of ice and snow.

249. It is usually cooler on a lawn than on dry ground.

250. Black clothes are warmer in the sunlight than clothes of any other color.

[pg 174]

CHAPTER SIX

SOUND

SECTION 28. *What sound is.*

What makes a dictaphone or a phonograph repeat your words?

What makes the wind howl when it blows through the branches of trees?

Why can you hear an approaching train better if you put your ear to the rail?

If you were to land on the moon tonight, and had with you a tank containing a supply of air which you could breathe (for there is no air to speak of on the moon), you might *try* to speak. But you would find that you had lost your voice completely. You could not say a word. You would open and close your mouth and not a sound would come.

Then you might try to make a noise by clapping your hands; but that would not work. You could not make a sound. "Am I deaf and dumb?" you might wonder.

The whole trouble would lie in the fact that the moon has practically no air. And sound is usually a kind of motion of the air,—hundreds of quick, sharp puffs in a second, so close together that we cannot feel them with anything less sensitive than the tiny nerves in our ears.

If you can once realize the fact that sound is a series of quick, sharp puffs of air, or to use a more scientific term, *vibrations* of air, it will be easy for you to understand most of the laws of sound.

[pg 175] A phonograph seems almost miraculous. Yet it works on an exceedingly simple principle. When you talk, the breath passing out of your throat makes the vocal cords vibrate. These and your tongue and lips make the air in front of you vibrate.

When you talk into a dictaphone horn, the vibrating air causes the needle at the small end of the horn to vibrate so that it traces a wavy line in the soft wax of the cylinder as the cylinder turns. Then when you run the needle over the line again it follows the identical track made when you talked into the horn, and it vibrates back and forth just as at first; this makes the air in the horn vibrate exactly as when you talked into the horn, and you have the same sound.

All this goes back to the fundamental principle that sound is vibrations of air; different kinds of

sounds are simply different kinds of vibrations. The next experiments will prove this.

Experiment 54. Turn the rotator rapidly, holding the corner of a piece of stiff paper against the holes in the disk. As you turn faster, does the sound become higher or lower? Keep turning at a steady rate and move your paper from the inner row of holes to the outer row and back again. Which row has the most holes in it? Which makes the highest sound? Hold your paper against the teeth at the edge of the disk. Is the pitch higher or lower than before? Blow through a blowpipe against the different rows of holes while the disk is being whirled. As the holes make the air vibrate do you get any sound?

This experiment shows that by making the air vibrate you get a sound.

The next experiment will show that when you have sound you are getting vibrations.

Experiment 55. Tap a tuning fork against the desk, then hold the prongs lightly against your lips. Can you feel them vibrate? Tap it again, and hold the fork close to your ear. Can you hear the sound?

[pg 176]

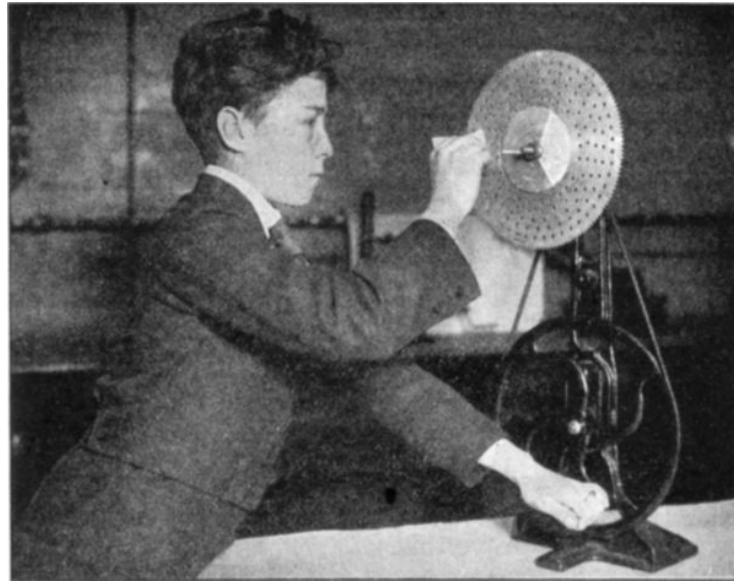

FIG. 96. An interesting experiment in sound.

The experiment which follows will show that we usually must have air to do the vibrating to carry the sound.

Experiment 56. Make a pad of not less than a dozen thicknesses of soft cloth so that you can stand an alarm clock on it on the plate of the air pump. The pad is to keep the vibrations of the alarm from making the plate vibrate. A still better way would be to set a tripod on the plate of the air pump and to suspend the alarm clock from the tripod by a rubber band. Set the alarm so that it will ring in 3 or 4 minutes, put it under the bell jar, and pump out the air. Before the alarm goes off, be sure that the air is almost completely pumped out of the jar. Can you hear the bell ring? Distinguish between a dull trilling sound caused by the jarring of the air pump when the alarm is on, and the actual *ringing* sound of the bell.

[pg 177]

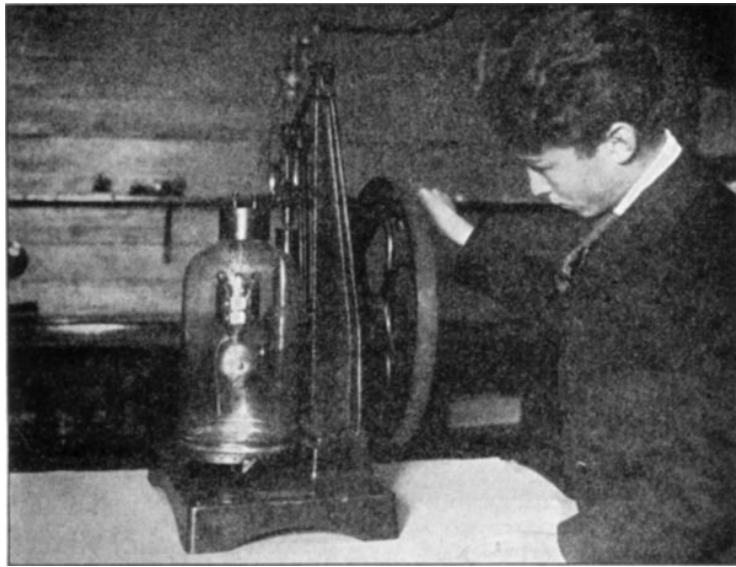

FIG. 97. When the air is pumped out of the jar, you cannot hear the bell ring.

The experiment just completed shows how we know there would be no sound on the moon, since there is practically no air around it. The next experiment will show you more about the way in which phonographs work.



FIG. 98. Making a phonograph record on an old-fashioned phonograph.

diaphragm. When the diaphragm vibrates with the needle, it makes a much larger surface of air vibrate than the needle alone could. Then the tube, like an ear trumpet, throws all the air vibrations in one direction, so that you hear the sound easily.

Experiment 58. Put a clean white sheet of paper around the recording drum, pasting the two ends together to hold it in place. Put a small piece of gum camphor on a dish just under the paper, light it, and turn the drum so that all parts will be evenly smoked. Be sure to turn it rapidly enough to keep the paper from being burned.

Experiment 57. Put a blank cylinder on the dictaphone, adjust the recording (cutting) needle and diaphragm at the end of the tube, start the motor, and talk into the dictaphone. Shut off the motor, remove the cutting needle, and put on the reproducing needle (the cutting needle, being sharp, would spoil the cylinder). Start the reproducing needle where the recording needle started, turn on the motor, and listen to your own voice.

Notice that in the dictaphone the air waves of your voice are all concentrated into a small space as they go down the tube. At the end of the tube is a diaphragm, a flat disk which is elastic and vibrates back and forth very easily. The air waves from your voice would not vibrate the needle itself enough to make any record; but they vibrate the diaphragm, and the needle, being fastened rigidly to it, vibrates with it.

In the same way, when the reproducing needle vibrates as it goes over the track made by the cutting needle, it would make air vibrations too slight for you to hear if it were not fastened to the



FIG. 99. A modern dictaphone.

Melt a piece of glass over a burner and draw it out into a thread. Break off about 8 inches of this glass thread and tie it firmly with cotton thread to the edge of one prong of a tuning fork. Clamp the top of the tuning fork firmly above the smoked drum, adjusting it so that the point of the glass thread rests on the smoked paper. Turn the handle slightly to see if the glass is making a mark. If it is not, adjust it so that it will. Now let some one turn the cylinder quickly and steadily. While it is turning, tap the tuning fork on the prong which has *not* the glass thread fastened to it. The glass point should trace a white, wavy line through the smoke on the paper. If it does not, keep on trying, adjusting the apparatus until the point makes a wavy line.

[pg 180]

Making a record in this way is, on a large scale, almost exactly like the making of a phonograph record. The smoked paper on which a tracing can easily be made as it turns is like the soft wax cylinder. The glass needle is like the recording needle of a phonograph. The chief difference is that you have struck the tuning fork to make it and the needle vibrate, instead of making it vibrate by air waves set in motion by your talking. It is because these vibrations of the tuning fork are more powerful and larger than are those of the recording needle of a phonograph that you can see the record on the recording drum, while you cannot see it clearly on the phonograph cylinder.

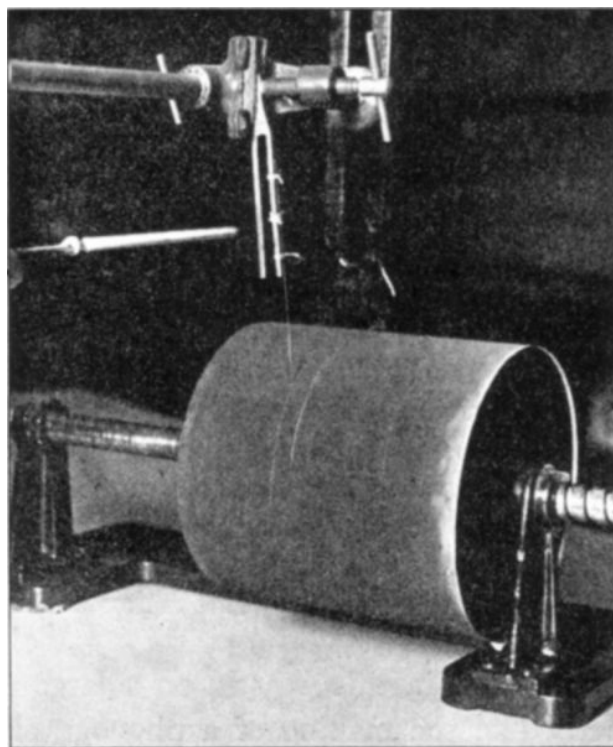

FIG. 100. How the apparatus is set up.

[pg 181]

In all ordinary circumstances, sound is the vibration of *air*. But in swimming we can hear with our ears under water, and fishes hear without any air. So, to be accurate, we should say that sound is

vibrations of any kind of matter. And the vibrations travel better in most other kinds of matter than they do in air. Vibrations move rather slowly in air, compared with the speed at which they travel in other substances. It takes sound about 5 seconds to go a mile in air; in other words, it would go 12 miles while an express train went one. But it travels faster in water and still faster in anything hard like steel. That is why you can hear the noise of an approaching train better if you put your ear to the rail.

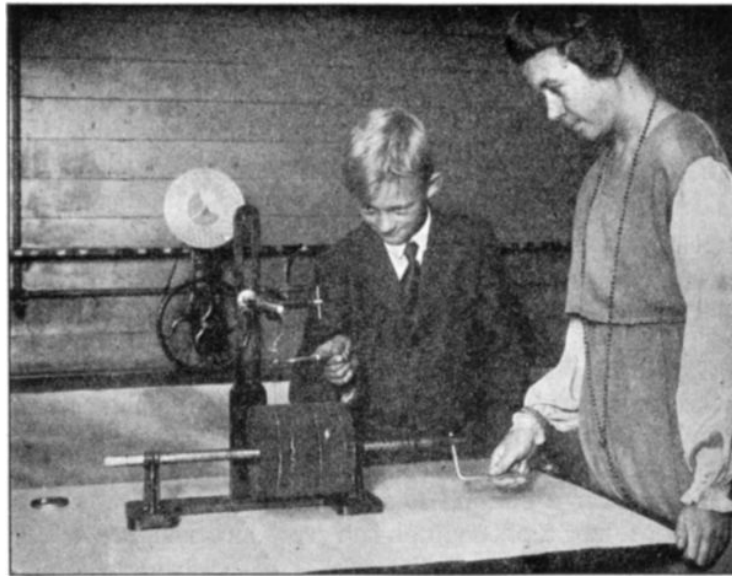

FIG. 101. When the tuning fork vibrates, the glass needle makes a wavy line on the smoked paper on the drum.

[pg 182]

Why we see steam rise before we hear a whistle blow. But even through steel, sound does not travel with anything like the speed of light. In the time that it takes sound to go a mile, light goes hundreds of thousands of miles, easily coming all the way from the moon to the earth. That is why we see the steam rise from the whistle of a train or a boat before we hear the sound. The sound and the light start together; but the light that shows us the steam is in our eyes almost at the instant when the steam leaves the whistle; the sound lags behind, and we hear it later.

Application 42. Explain why a bell rung in a vacuum makes no noise; why the clicking of two stones under water sounds louder if your head is under water, than the clicking of the two stones in the air sounds if your head is in the air; why you hear a buzzing sound when a bee or a fly comes near you; how a phonograph can reproduce sounds.

Inference Exercise

Explain the following:

251. The paint on woodwork blisters when hot.
252. You can screw a nut on a bolt very much tighter with a wrench than with your fingers.
253. When a pipe is being repaired in the basement of a house, you can hear a scraping noise in the faucets upstairs.
254. Sunsets are unusually red after volcanic eruptions.
255. Thunder shakes a house.
256. Shooting stars are really stones flying through space. When they come near the earth, it pulls them swiftly down through the air. Explain why they glow.
257. At night it is difficult to see out through a closed window of a room in which a lamp is lighted.
258. When there is a breeze you cannot see clear reflections in a lake.
259. Rubbing with coarse sandpaper makes rough wood smooth.
260. A bow is bent backward to make the arrow go forward.

[pg 183]

SECTION 29. *Echoes.*

When you put a sea shell to your ear, how is it that you hear a roar in the shell?

Why can you sometimes hear an echo and sometimes not?

If it were not for the fact that sound travels rather slowly, we should have no echoes, for the sound would get back to us practically at the instant we made it. An echo is merely a sound, a series of air vibrations, bounced back to us by something at a distance. It takes time for the vibration which we start to reach the wall or cliff that bounces it back, and it takes as much more time for the returning vibration to reach our ears. So you have plenty of time to finish your shout before the sound bounces back again. The next experiment shows pretty well how the waves, or vibrations, of sound are reflected; only in the experiment we use waves of water because they go more slowly and we can watch them.

Experiment 59. Fill the long laboratory sink (or the bathtub at home) half full of water and start a wave from one end. Watch it move along the side of the sink. Notice what happens when it reaches the other end.

Air waves do the same thing; when they strike against a flat surface, they bounce back like a rubber ball. If you are far enough away from a flat wall or cliff, and shout, the sound (the air vibrations you start) is reflected back to you and you hear the echo. But if you are close to the walls, as in an empty room, the sound *reverberates*; it bounces back and forth from one wall to the other so rapidly that no distinct echo is heard, and there is merely a confusion of sound.

[pg 184]



FIG. 102. When the wave reaches the end of the sink, it is reflected back. Sound waves are reflected in the same way.

When you drop a pebble in water, the ripples spread in all directions. In the same way, when you make a sound in the open air, the air waves spread in all directions. But when you shout through a megaphone the air waves are all concentrated in one direction and consequently they are much stronger in that direction. However, while the megaphone intensifies sound, the echoing from the sides of the megaphone makes the sound lose some of its distinctness.

Why it is hard to understand a speaker in an empty hall. A speaker can be heard much more easily in a room full of people than in an empty hall. The sound does not reflect well from the soft clothes of the audience and the uneven surfaces of their bodies, just as a rubber ball does not bounce well in sand. So the sound does not reverberate as in an empty hall.

[pg 185]

Application 43. Explain why a carpeted room is quieter than one with a bare floor; why you shout through your hands when you want to be heard at a distance.

Inference Exercise

Explain the following:

261. It is harder to walk when you shuffle your feet.
262. The air over a lamp chimney, or over a register in a furnace-heated house, is moving upward rapidly.
263. The shooting of a gun sounds much louder within a room than it does outdoors.
264. A drum makes a loud, clear sound when the tightened head is struck.
265. The pull of the moon causes the ocean tides.
266. Sand is sometimes put in the bottom of vases to keep them from falling over.

267. It is difficult to understand clearly the words of one who is speaking in an almost empty hall.

268. The ridges in a washboard help to clean the clothes that are rubbed over them.

269. One kind of mechanical toy has a heavy lead wheel inside. When you start this to whirling, the toy runs for a long time.

270. If you raise your finger slightly after touching the surface of water, the water comes up with your finger.

SECTION 30. *Pitch.*

What makes the keys of a piano give different sounds?

Why does the moving of your fingers up and down on a violin string make it play different notes?

Why is the whistle of a peanut roaster so shrill, and why is the whistle of a boat so deep?

[pg 186]

Did you ever notice how tiresome the whistle on a peanut roaster gets? Well, suppose that whenever you spoke you had to utter your words in exactly that pitch; that every time a car came down the street its noise was like the whistle of the peanut roaster, only louder; that every step you took sounded like hitting a bell of the same pitch; that when you went to the moving-picture theater the orchestra played only the one note; that when any one sang, his voice did not rise and fall; in short, that all the sounds in the world were in one pitch. That is the way it would be if different kinds of air vibrations did not make different kinds of notes,—if there were no differences in pitch.

Pitch due to rapidity of vibration. When air vibrations are slow,—far apart,—the sound is low; when they are faster, the sound is higher; when they are very quick indeed, the sound is very shrill and high. In various ways, as by people talking and walking and by the running of street cars and automobiles, all sorts of different vibrations are started, giving us a pleasant variety of high and low and medium pitches in the sounds of the world around us.

An experiment will show how pitch varies and how it is regulated:

Experiment 60. Move the slide of an adjustable tuning fork well up from the end of the prongs, tap one prong lightly on the desk, and listen. Move the slide somewhat toward the end of the prongs, and repeat. Is a higher or a lower sound produced as the slide shortens the length of the prongs?

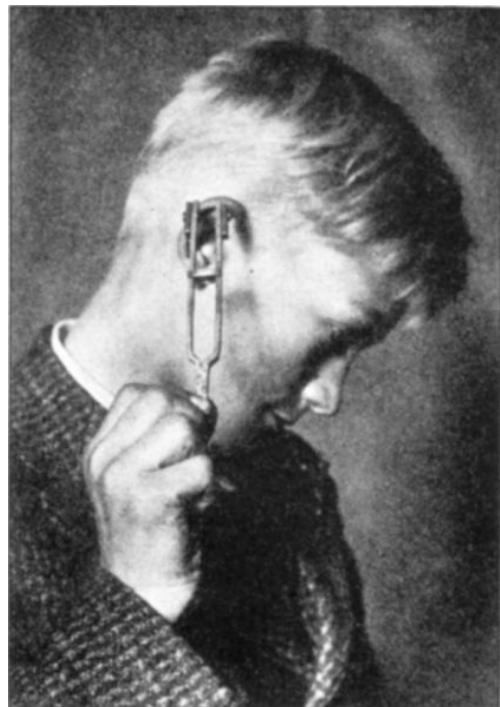

[pg 187]

Whistle a low note, then a high one. Notice what you do with your lips; when is the opening the smaller? Sing a low note, then a high one. When are the cords in your throat looser? Fill a drinking glass half full of water, and strike it. Now pour half the water out, and strike the glass again. Do you get the higher sound when the column of water is shorter or when it is longer? Stretch a rubber band across your thumb and forefinger. Pick the band as you make it tighter, not making it longer, but pulling it tighter with your other fingers. Does it make a higher or a lower sound as you increase the tightness? Stretch the band from your thumb to your little finger and pick it; now put your middle finger under the band so as to divide it in halves, and pick it again. Does a short strand give a higher or lower pitch than a long strand?

FIG. 103. When the prongs of the tuning fork are made longer or shorter, the pitch of the sound is changed.

A violinist tunes his violin by tightening the strings; the tighter they are and the thinner they are, the higher the note they give. Some of the strings are naturally higher than others; the highest is a smaller, finer string than the lowest. When the violinist plays, he shortens the strings by holding them down with his fingers, and the shorter he makes them the higher the note. A bass drum is much larger than a high-pitched kettledrum. The pipes of an organ are long and large for the low notes, shorter and smaller for the high ones.

[pg 188]

In general, the longer or larger the object is that vibrates, the slower the rate of vibration and consequently the lower the pitch. But the shorter or finer the object is that vibrates, the higher the rate of vibration and the higher the pitch.

All musical instruments contain devices which can be made to vibrate,—either strings or columns of air, or other things that swing to and fro and start waves in the air. And by tightening them, or making them smaller or shorter, the pitch can be made higher; that is, the number of vibrations to each second can be increased.

Application 44. Explain why a steamboat whistle is usually of much lower pitch than is a toy whistle; why a banjo player moves his fingers toward the drum end of the banjo when he plays high notes; why the sound made by a mosquito is higher in pitch than that made by a bumblebee.

Application 45. A boy had a banjo given him for Christmas. He wanted to tune it. To make a string give a higher note, should he have tightened or loosened it? Or could he have secured the same result by moving his finger up and down the string to lengthen or shorten it?

Application 46. A man was tuning a piano for a concert. The hall was cold, yet he knew it would be warm at the time of the concert. Should he have tuned the piano to a higher pitch than he wanted it to have on the concert night, to the exact pitch, or to a lower pitch?

Inference Exercise

Explain the following:

271. A cowboy whirls his lasso around and around his head before he throws it.

272. Furnaces are always placed in the basements of buildings, never on top floors.

[pg 189]

273. A rather slight contraction of a muscle lifts your arm a considerable distance.

274. A player on a slide trombone changes the pitch of the notes by lengthening and shortening the tube while he blows through it.

275. Rain runs off a tar roof in droplets, while on shingles it soaks in somewhat and spreads.

276. There is a sighing sound as the wind blows through the branches of trees, or through stretched wires or ropes.

277. Sometimes a very violent noise breaks the membrane in the drum of a person's ear.

278. As a street car goes faster and faster, the hum of its motor is higher and higher.

279. If a street is partly dry, the wet spots shine more than the dry spots do.

280. Molten type metal, when poured into a mold, becomes hard, solid type when it cools.

[pg 190]

CHAPTER SEVEN

MAGNETISM AND ELECTRICITY

SECTION 31. *Magnets; the compass.*

What makes the needle of a compass point north?

What causes the Northern Lights?

For many hundreds of years sailors have used the compass to determine directions. During all this time men have known that one point of the needle always swings toward the north if there is no iron near to pull it some other way, but until within the past century they did not know why. Now we have found the explanation in the fact that the earth is a great big magnet. The experiment which follows will help you to understand why the earth's being a magnet should make the compass needle point north and south.

Experiment 61. Lay a magnetic compass flat on the table. Notice which point swings to the north. Now hold a horseshoe magnet, points down, over the compass. Turn the magnet around and watch the compass needle; see which end of the magnet attracts the north point; hold that end of it toward the south point and note the effect. Hold the magnet, ends up, under the table directly below the compass and turn the magnet, watching the compass needle.

The earth is a magnet, and it acts just as your magnet does: one end attracts one point of the compass, and the other end attracts the other point. That ought to make it clear why the compass points north. But how is the compass made? The next experiment will show this plainly.

Experiment 62. Take a long shoestring and make a loop in one end of it. Slip the magnet through the loop and suspend it, ends down. Fasten the shoestring to the top of a doorway so that the magnet can swing easily. Steady the magnet and let it turn until it comes to a rest. Mark the end that swings to the north. Turn this end around to the south; let go and watch it. Place the magnet the other way around in the loop so that you can be sure that it is not twisting of the shoestring that makes the magnet turn in this direction.



FIG. 104. The compass needle follows the magnet.

Now stroke a needle several times along one arm of the magnet, *always in the same direction*, as shown in Figure 105. Hold the needle over some iron filings or touch any bit of iron or steel with it. What has the needle become? Lay it on a cardboard milk-bottle top of the flat kind, and on that float it in the middle of a glass or earthenware dish of water. Notice which end turns north. Turn this end to the south and see what happens. Hold your magnet, ends up, under the dish, and turn the magnet. What does the needle do?

Now it should be easy to understand why the compass points north. One end of any magnet pulls on *one* end of another magnet and drives the *other* end away. The earth is a big magnet. So if you make a magnet and balance it in such a way that it is free to swing, the north end of the big earth magnet pulls one end of the little magnet toward it and pushes the other end away. Therefore one end of your compass always points north.

Other effects of the earth's magnetism. Another interesting effect of the earth's being a big magnet is to be seen if you lay a piece of steel so that it points north and south, and then pound it on one end. It becomes magnetized just as your needle became magnetized when it was rubbed on the small magnet.



FIG. 105. Magnetizing a needle.



FIG. 106. A compass made of a needle and a piece of cardboard.

And still another effect of the earth's magnetism is this: Tiny particles of electricity, called *electrons*, are probably shooting through space from the sun. It is believed that as they come near the earth, the magnetism of the north and south polar regions attracts them toward the poles, and that as they rush through the thin, dry upper air, they make it glow. And this is probably what causes the Northern Lights or Aurora Borealis.

What happens when a needle is magnetized. The reason that a needle becomes magnetic if it is rubbed over a magnet is probably this: Every molecule of iron may be an extremely tiny magnet; if it is, each molecule has a north and south pole like the needle of a compass. In an ordinary needle (or in any unmagnetized piece of iron or steel) these molecules would be facing every way, as shown in Figure 107.

But

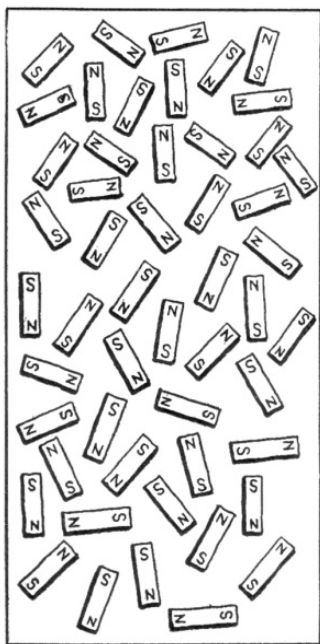

FIG. 107. Diagram of molecules in unmagnetized iron. The north and south poles of the molecules are supposed to be pointing in all directions.

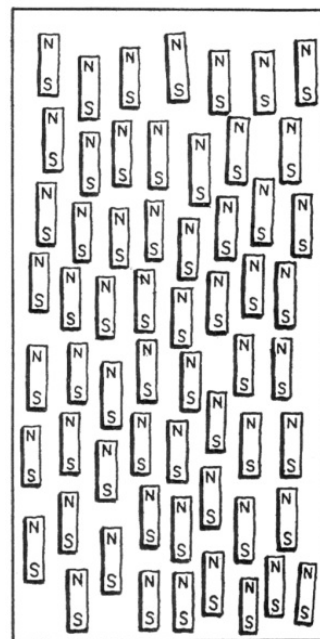

FIG. 108. Diagram of magnetized iron. The north and south poles of the molecules are all supposed to point in the same direction.

when a piece of steel or iron that is already magnetized is brought near the unmagnetized needle, all the north poles of the molecules of the needle are pulled in the same direction—it is almost like combing tangled hair to stroke a needle over a magnet. Then the molecules are arranged more as shown in Figure 108. When all the molecules, each of which is a tiny magnet, pull in the same direction, they make a strong magnet, and they magnetize any iron that comes near them just as they were magnetized.

Steel will stay magnetized a long time; but ordinary soft iron loses magnetism almost as soon as another magnet is taken away from it,—the molecules become all disarranged again.

In a later section you will find that whenever electricity flows through a wire that is coiled around a piece of iron, the iron becomes magnetized just as when it is rubbed with a magnet.

Application 47. An explorer lost his compass. In clear weather he could tell the directions by the sun and stars, but in cloudy weather he was badly handicapped. He had with him a gun, plenty of ammunition, a sewing kit, a hunting knife, and some provisions. How could he have made a compass?

Inference Exercise

Explain the following:

281. Snow turns to water in the first warm weather.

282. A person's face looks ghastly by the greenish light of a mercury-vapor lamp.

283. If a red-hot coal is touched with a cold poker, the coal turns black at the place touched.

284. Stereopticon slides are put in upside down, yet the picture on the screen is right side up.

285. If the vocal cords of your throat did not vibrate, you could not talk out loud.

286. A watch is sometimes put out of order if it is held near a magnet.

287. The water will be no higher on the inside of a leaky boat than it is on the outside.

288. A bass viol is considerably larger than a violin.

289. Ships that are used by men testing the earth's magnetism carry very sensitive compasses. Explain why such ships are made entirely of wood and brass.

290. Thunder rolls; that is, after the first peal there is a reverberating sound that becomes less and less distinct.

SECTION 32. *Static electricity.*

What is electricity?

What makes thunder and lightning?

Why does the barrel or cap of a fountain pen pick up small bits of paper after it has been rubbed on your coat sleeve?

Why do sparks fly from the fur of a cat when you stroke it in the dark?

The Greeks, 2000 years ago, knew that there was such a thing as electricity, and they used to get it by rubbing amber with silk. In the past century men have learned how to make electricity do all sorts of useful work: making boats and cars and automobiles go, ringing bells, furnishing light, and, in the telephone and telegraph, carrying messages. But no one knew what electricity really was until, within the last 25 years, scientists found out.

Atoms and electrons. When we talked about molecules, we said that they were as much smaller than a germ as a germ is smaller than a mountain. Well, a molecule is made up, probably, of some things that are much smaller still,—so small that people thought that nothing could be smaller. Those unthinkably tiny things are called *atoms*; you will hear more about them when you come to the parts of this book that tell about chemistry.

But if you took the smallest atom in the world and divided it into 1700 pieces, each one of these would be about the size of a piece of electricity.

Electricity is made up of the tiniest things known to man—things so small that nobody really can think of their smallness. These little pieces of electricity are called *electrons*, and for all their smallness, scientists have been able to find out a good deal about them. They have managed to get one electron all by itself on a droplet of oil and they have seen how it made the oil behave. Of course they could not see the electron, but they could tell from various experiments that they had just one. Scientists know how many trillions of electrons flow through an incandescent electric

lamp in a second and how many quadrillions of them it would take to weigh as much as a feather. They know what the electrons do when they move, how fast they can move, and what substances let electrons move through them easily and what substances hold them back; and they know perfectly well how to set them in motion. How the scientists came to know all these things you will learn in the study of physics; it is a long story. But you can find out some things about electrons yourself. The first experiment is a simple one such as the Greeks used to do with amber.

[pg 198]



FIG. 109. When the comb is rubbed on the coat, it becomes charged with electricity.

Experiment 63. Rub a hard rubber comb on a piece of woolen cloth. The sleeve of a woolen coat or sweater will do. Rub the comb quickly in the same direction several times. Now hold it over some small bits of paper or sawdust. What does it do to them? Hold it over some one's hair. The rest of this experiment will work well only on cool, clear days. Rub the comb again, a dozen or more times in quick succession. Now touch it gently to the lobe of your ear. Do you hear the snap as the small spark jumps from the comb to your ear?

Pull a dry hair out of your head and hold it by one end. Charge your comb by rubbing it again, and bring it near the loose end of the hair. If the end of the hair clings to the comb at first, leave it clinging until it flies off. Now try to touch the hair with the comb. Next, pinch the end of the hair between your thumb and finger and again bring the charged comb near it. Is the hair attracted or repelled? After touching the comb what does it do?

You can get the same effects by rubbing glass or amber on silk.

with electricity. There are probably electrons in everything. But when there is just the usual number of electrons in an object, it acts in an ordinary way and we say that it is not charged with electricity. If there are more than the usual number of electrons on an object, however, we say that it is *negatively charged*, or that it has a negative charge of electricity on it. But if there are fewer electrons than usual in an object, we say that it has a positive charge of electricity on it, or that it is *positively charged*.

Objects negatively and positively charged

[pg 199]

You might expect a "negative charge" to indicate fewer electrons than usual, not more. But people called the charge "negative" long before they knew anything about electrons; and it is easier to keep the old name than to change all the books that have been written about electricity. So we still call a charge "negative" when there are unusually *many* electrons, and we call it "positive" when there are unusually *few*. A *negative charge* means that more electrons are present than usual. A *positive charge* means that fewer electrons are present than usual.

Before you rubbed your comb on wool, neither the comb nor the wool was charged; both had just the usual number of electrons. But when you rubbed them together, you rubbed some of the electrons off the wool on to the comb. Then the comb had a negative charge; that is, it had too many electrons—too many little particles of electricity.



FIG. 110. The charged comb picks up pieces of paper.

When you brought the comb near the hair, the hair had fewer electrons than the comb. Whenever one object has more electrons on it than another, the two objects are pulled toward each other; so there was an attraction between the comb and the hair, and the hair came over to the comb. As soon as it touched the comb, some of the extra electrons jumped from the comb to the hair. The electrons could not get off the hair easily, so they stayed there. Electrons repel each

[pg 200]

other—drive each other away. So when you had a number of electrons on the end of the comb and a number on the end of the hair, they pushed each other away, and the hair flew from the comb. But when you pinched the hair, the electrons could get off it to your moist hand, which lets electricity through it fairly easily. Then the comb had extra electrons on it and the hair did not; so the comb pulled the hair over toward it again.

When you brought the charged comb near your ear, some of the electrons on the comb pushed the others off to your ear, and you heard them snap as they rushed through the air, making it vibrate.

How lightning and thunder are caused. In thunderstorms the strong currents of rising air blow some of the forming raindrops in the clouds into bits of spray. The tinier droplets get more than their share of electrons when this happens and are carried on up to higher clouds. In this way clouds become charged with electricity. One cloud has on it many more electrons than another cloud that is made, perhaps, of lower, larger droplets. The electricity leaps from the cloud that has the greater number of electrons to the cloud that has the less number, or it leaps from the heavily charged cloud down to a tree or house or the ground. You see the electricity leap and call it *lightning*. Much more leaps, however, than leaped from the comb to your ear, and so it makes a very much louder snap. The snap is caused in this way: As the electric spark leaps through the air, it leaves an empty space or vacuum immediately behind it. The air from all sides rushes into the vacuum and collides there; then it bounces back. This again leaves a partial vacuum; so the air rushes in once more, coming from all sides at once, and again bounces back. This starts the air vibrations which we call *sound*. Then the sound is echoed from cloud to cloud and from the clouds to the earth and back again, and we call it *thunder*.

[pg 201]

The electricity you have been reading about and experimenting with in this section is called *static electricity*. "Static" means standing still. The electricity you rubbed up to the surface of the comb or glass stayed still until it jumped to the bit of paper or hair; then it stayed still on that. This was the only kind of electricity most people knew anything about until the nineteenth century; and it is not of any great use. Electricity must be flowing through things to do work. That is why people could not invent electric cars and electric lights and telephones before they knew how to make electricity flow steadily rather than just to stand still on one thing until it jumped across to another and stood there. In the next chapter we shall take up the ways in which electrons are made to flow and to do work.

Application 48. Explain why the stroking of a cat's back will sometimes cause sparks and make the cat's hairs stand apart; why combing sometimes makes your hairs fly apart. Both of these effects are best secured on a dry day, because on a damp day the water particles in the air will let the electrons pass to them as fast as they are rubbed up to the surface of the hair.

[pg 202]

Inference Exercise

Explain the following:

291. If you shuffle your feet on a carpet in clear, cold weather and then touch a person's nose or ear, a slight spark passes from your finger and stings him.

292. If you stay out in the cold long, you get chilled through.

293. The air and earth in a greenhouse are warmed by the sun through the glass even when it is cold outside and when the glass itself remains cold.

294. When you hold a blade of grass taut between your thumbs and blow on it, you get a noise.

295. Shadows are usually black.

296. Some women keep magnets with which to find lost needles.

297. You can grasp objects much more firmly with pliers than with your fingers.

298. If the glass in a mirror is uneven, the image of your face is unnatural.

299. A sweater clings close to your body.

300. Kitchens, bathrooms, and hospitals should have painted walls.

[pg 203]

CHAPTER EIGHT

ELECTRICITY

SECTION 33. *Making electricity flow.*

What causes a battery to produce electricity?

What makes electricity come into our houses?

The kind of electricity you get from rubbing (friction) is not of much practical use, you remember. Men had to find a way to get a steady current of electricity before they could make electricity do any work for them. The difference between static electricity—when it leaps from one thing to another—and flowing electricity is a good deal like the difference between a short shower of rain and a river. Both rain and river are water, and the water of each is moving from one place to another; but you cannot get the raindrops to make any really practical machine go, while the rivers can do real work by turning the wheels in factories and mills.

Within the past century two devices for making electricity flow and do work have been perfected: One of these is the electric battery; the other is the dynamo.

[pg 204]

The electric battery. A battery consists of two pieces of different kinds of metal, or a metal and some carbon, in a chemical solution. If you hang a piece of zinc and a carbon, such as comes from an arc light, in some water, and then dissolve sal ammoniac in the water, you will have a battery. Some of the molecules of the sal ammoniac divide into two parts when the sal ammoniac gets into the water, and the molecules continue to divide as long as the battery is in use or until it "wears out." One part of each molecule has an unusually large number of electrons; the other part has unusually few. The parts with unusually large numbers of electrons gather around the zinc; so the zinc is *negatively charged*,—it has more than the ordinary number of electrons. The part of the sal ammoniac with unusually few electrons goes over to the carbon; so the carbon is *positively charged*,—it has fewer than the ordinary number of electrons.

Making the current flow. Now if we can make some kind of bridge between the carbon and the zinc, the electrons will flow from the place where there are many to the place where there are few. Electrons can flow through copper wire very easily. So if we fasten one end of the copper wire to the carbon and the other end to the zinc, the electrons will flow from the zinc to the carbon as long as there are more electrons on the zinc; that is, until the battery wears out. Therefore we have a steady flow of electricity through the wire. While the electricity is flowing from one pole to the other, we can make it do work.

Experiment 64. Set up two or three Samson cells. They consist of a glass jar, an open zinc cylinder, and a smaller carbon cylinder. Dissolve a little over half a cup of sal ammoniac in water and put it into the glass jar; then fill the jar with water up to the line that is marked on it. Put the carbon and zinc which are attached to the black jar cover into the jar. Be careful not to let the carbon touch the zinc. One of these cells will probably not be strong enough to ring a doorbell for you; so connect two or three together in series as follows:

[pg 205]

Fasten a piece of copper wire from the carbon of the first cell to the zinc of the second. If you have three cells, fasten another piece of wire from the carbon of the second cell to the zinc of the third, as shown in Figure 111.



FIG. 111. A wet battery of three cells connected to ring a bell.

Fasten one end of a copper wire to the zinc of the first cell and the other end of this wire to one binding post of an electric bell. Fasten one end of another piece of copper wire to the carbon of the third cell, if you have three, and touch the other end of this wire to the free binding post of the electric bell. If you have everything connected rightly, the bell should ring.

Different kinds of batteries. There are many different kinds of batteries. The one you have just made is a simple one frequently used for doorbells. Other batteries are more complicated. Some are made with copper and zinc in a solution of copper sulfate; some, even, are made by letting electricity from a dynamo run through a solution from one lead plate to another until a chemical

[pg 206]

substance is stored on one of them; then, when the two lead plates are connected by a wire, the electrons run from one to the other. This kind of battery is called a *storage battery*, and it is much used in submarines and automobiles.



FIG. 112. A battery of three dry cells.

But all the different batteries work on the same general principle: A chemical solution divides into two parts, one with many electrons and the other with a less number. One part of the solution gathers on one pole (piece of metal in the solution) and charges it positively; the other part gathers on the other pole and charges it negatively. Then the electricity flows from one pole to the other.

Positive and negative poles. Before people knew anything about electrons, they knew that electricity flowed from one pole of a battery to the other. But they always said that it flowed from the carbon to the zinc; and they called the carbon the positive pole and the zinc the negative. Although we now know that the electrons flow from the zinc to the carbon, it is much more convenient to use the old way of speaking, as was explained on page 199. Practically, it makes no difference which way the electrons are going as long as a current of electricity is flowing through the wire from one pole of the battery to the other pole. So every one speaks of electricity as flowing from the positive pole of a battery (usually the carbon or copper) to the negative pole (usually the zinc), although the electrons actually move in the other direction.

[pg 207]

Batteries make enough electricity flow to do a good deal of work. But they are rather expensive, and it takes a great many to give a flow of electricity sufficient for really heavy work, such as running street cars or lighting a city. Fortunately there is another way of getting large amounts of electricity to flow. This is by means of dynamos.

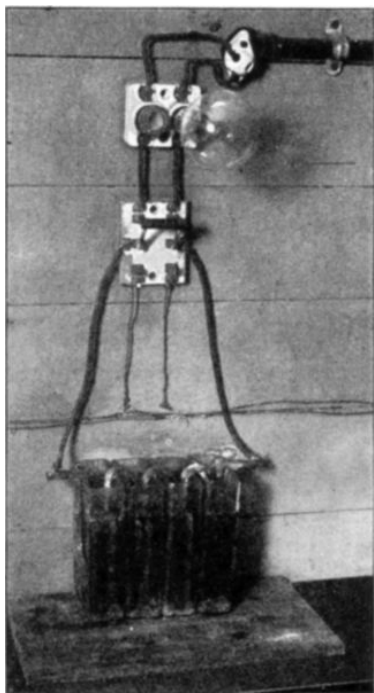

FIG. 113. A storage battery.

How a dynamo makes a current flow. To understand a dynamo, you must first realize that there are countless electrons in the world—perhaps all things are made entirely of them. But you remember that when we want to get these electrons to do work we must make them flow. This can be done by spinning a loop of wire between the poles of a magnet. Whenever a loop of wire is turned between the two poles of a magnet, the magnetism pushes the electrons that are already in the wire around and around the loop. As long as we keep the loop spinning, a current of electricity flows.

[pg 208]

If only one loop of wire is spun between the poles of a magnet, the current is very feeble. If you loop the wire around twice, as shown in Figure 114, the magnet acts on twice as much of the wire at the same time; so the current is stronger. If a very long piece of wire is used and is looped around many times, and the whole coil is spun rapidly between the poles of a powerful magnet, myriads of the electrons in the wire rush around and around the loops—a powerful current of electricity flows through the wire.

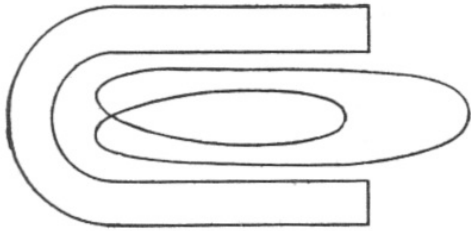

FIG. 114. Spinning loops of wire between the poles of a magnet causes a current of electricity to flow through the wire.

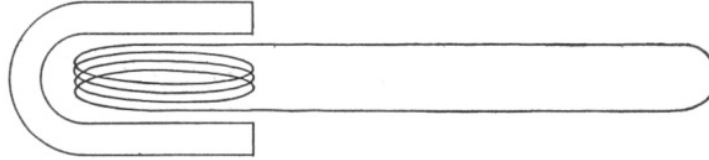

FIG. 115. The more loops there are, the stronger the current.

Now suppose you bring one loop of the long wire out, as shown in Figure 115, and suppose you spin the rest of the loops between the poles of the magnet. Then, to flow through the loops by the magnet the electricity will have to go clear out through the long loop and back again. While it is flowing through this long loop, we can make it work. We can cut the long loop and attach one broken end to one part of an electric lamp and the other end to the other part, so that the electricity has to flow through the lamp in order to get back to the spinning coil of wire, as shown in Figure 116. Such an arrangement as this is really an extremely simple dynamo.

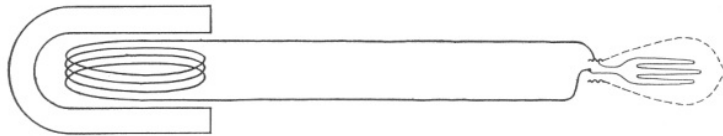

FIG. 116. If the electricity passes through a lamp on its way around the circuit the filament of the lamp glows.

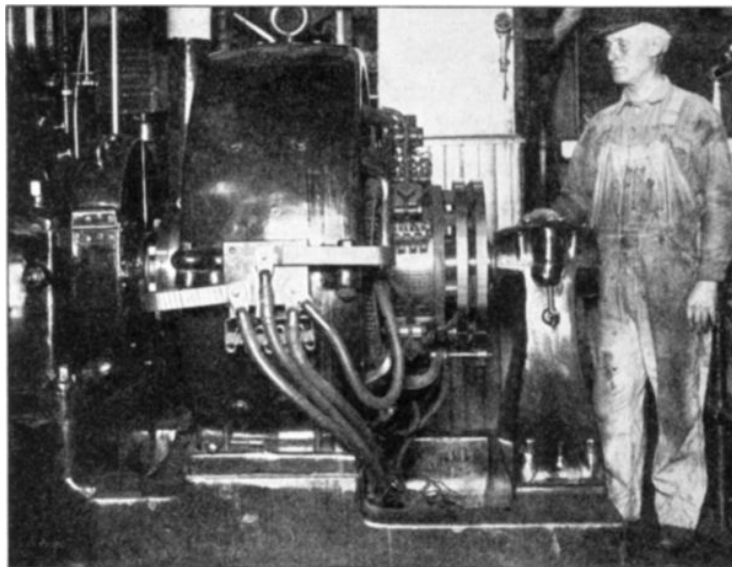

FIG. 117. A dynamo in an electric light plant.

You could make a dynamo that would actually work, by arranging such an apparatus so that the coil would spin between the poles of the magnet. But of course the big commercial dynamos are very much more complicated in their construction. Figure 116 shows only the general principle on which they work. The main point to note is that by spinning a coil of wire between the poles of a magnet, you can make electricity flow rapidly through the wire. And it is in this way that most of the electricity we use is made.

[pg 209]

[pg 210]

The power spinning the coil of wire is sometimes steam, and sometimes gasoline or distillate; and water power is very often used. A large amount of our electricity comes from places where there are waterfalls. Niagara, for instance, turns great dynamos and generates an enormous amount of electricity.

Why many automobiles have to be cranked. In an automobile, the magneto is a little dynamo that makes the sparks which explode the gasoline. While the automobile is going the engine spins the coil of wire between the magnets, but at starting you have to spin the coil yourself; and doing that is called "cranking" the automobile. "Self-starters" have a battery and motor to spin the coil for you until the engine begins to go; then the engine turns the coil of the magneto.

[pg 211]

How old-fashioned telephones are rung. The old-fashioned telephones, still often used in the country, have little cranks that you turn to ring for central. The crank turns a coil of wire between the poles of the magnet and generates the electricity for ringing the bell. These little dynamos, like those in automobiles, are usually called magnetos.



FIG. 118. The magneto in an automobile is a small dynamo.

Alternating current. For the sake of simplicity and convenience we speak of electricity as always flowing in through one wire and out through the other. With batteries this is actually the case. It is also the case where people have what is called *direct-current* (d. c.) electricity. But it is easier to raise and lower the voltage (pressure) of the current if instead of being direct it is *alternating*; that is, if for one instant the electricity flows in through one wire and out through the other, the next instant flowing the opposite way, then the first way again, and so on. This kind of current is called *alternating current* (a. c.), because the current alternates, coming in the upper wire and out of the lower for a fraction of a second; then coming in the lower and out of the upper for the next fraction of a second; then coming in the upper again and out of the lower for a fraction of a second; and so on, back and forth, all the time. For heating and lighting, this alternating current is just as good as the direct current, and it is probably what you have in your own home. For charging storage batteries and making electromagnets, separating water into two gases, and for running certain kinds of motors, however, the direct current is necessary. Find out whether the current in your laboratory is direct or alternating.

[pg 212]

Application 49. Explain why we need fuel or water to generate large currents of electricity; how we can get small amounts of electricity to flow without using dynamos; why automobiles must be cranked unless they have batteries to start them.

Inference Exercise

Explain the following:

301. Mexican water jars are made of porous clay; the water that seeps through keeps the water inside cool.

302. When you crank an automobile, electricity is generated.

303. Potatoes will not cook any more quickly in water that is boiling violently than in water that is boiling gently.

304. When you brush your hair on a winter morning, it sometimes stands up and flies apart more and more as you continue to brush it.

305. You cannot see a person clearly through a ground-glass window, although it lets most of the light through.

[pg 213]

306. There is a layer of coarse, *light-colored* gravel over the tar on roofs, to keep the tar from melting.

307. It is very easy to slip on a well-waxed hardwood floor.

308. If you have a silver filling in one of your teeth and you touch the filling with a fork or spoon, you get a slight shock.

309. You can shake a thing down into a bottle when it will not slip down by itself.

310. If you rub a needle across one pole of a magnet three or four times in the same direction, then float it on a cork in water one end of the needle will point north.

SECTION 34. *Conduction of electricity.*

How does electricity travel?

Why do you get a shock if your hands are wet when you touch a live wire?

If you were to use a piece of string instead of a copper wire to go from one pole of a battery to another or to spin between the poles of the magnet of the dynamo, you could get no flow of electricity to speak of. Electrons do not flow through string easily, but they flow through a copper wire very easily. Anything that carries, or conducts, electricity well is called a *good conductor*. Anything that carries it poorly is called a *poor conductor*. Anything that allows practically no electricity to pass through it is called an *insulator*.

Experiment 65.⁵ Turn on an electric lamp. Turn it off by opening the knife switch. Cover the blade of the knife switch with a fold of paper and close it. Will the lamp glow? Try a fold of dry cloth; a fold of the same cloth wet. Connect the blade to the slot with a piece of iron; with a piece of glass; with porcelain; with rubber; with dry wood; with wood that is soaking wet; with a coin. Which of these are good conductors of electricity? Which could be used as insulators?

Footnote 5: Read footnote, page [226](#), before doing this experiment.

[pg 214]



FIG. 119. Electricity flows through the coin.

How you can get an electrical shock. A person's body is not a very good conductor of electricity, but will conduct it somewhat. When electricity goes through your body, you get a shock. The shock from the ordinary current of electricity, 110 volts, is not enough to injure you at all; in fact, if you were standing on dry wood, it would be *safe*, although you would get a slight shock, to connect the blade of a knife switch to the slot of the switch, through your hand or body. Your body would not allow enough current to pass through it to light the lamp. Stronger currents, like those of power lines and even trolley wires, are extremely dangerous.

[pg 215]

All the electric wires entering your house are made of copper. They are all covered with cloth and rubber and are fastened with glass or porcelain knobs. The reason is simple: Copper and

practically all other metals are very good conductors of electricity; that is, they allow electricity to pass through them very easily. Cloth, rubber, glass, and porcelain are very poor conductors, and they are therefore used as insulators,—to keep the electricity from going where you do not want it to go.

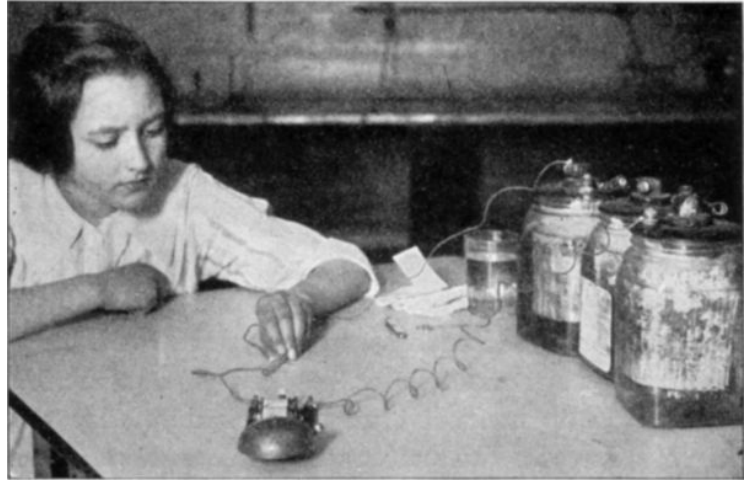

FIG. 120. Will electricity go through the glass?

Experiment 66. To each binding post of an electric bell fasten a piece of insulated copper wire with bare ends and at least 4 feet long. Connect the free end of one of these wires with one pole of a battery, using a regular laboratory battery or one you made yourself. Attach one end of another piece of wire a foot or so long, with bare ends, to the other pole of the battery. Touch the free end of this short wire to the free end of the long wire, as shown in Figure 120. Does the bell ring? If it does not, something is wrong with the connection or with the battery; fix them so that the bell will ring. Now leave a gap of about an inch between the free end of the long wire and the free end of the short wire. Try making the electricity flow from the short wire into the long one through a number of different things, such as string, a key, a knife, a piece of glass tubing, wet cloth, dry cloth, rubber, paper, a nail, a dish of mercury (dip the ends of the wire into the dish so that they both touch the mercury at the same time), a dish of water, a stone, a pail, a pin, and anything else that you may like to try.

[pg 216]

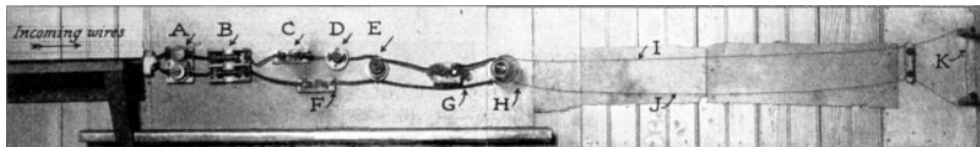

FIG. 121. Electrical apparatus: A, plug fuse; B, cartridge fuse; C, knife switch; D, snap switch; E, socket with nail plug in it; F, fuse gap; G, flush switch; H, lamp socket; I, J, K, resistance wire.

Each thing that makes the bell ring is a good conductor. Each one that will not make it ring is a poor conductor or an insulator. Make a list of the things you have tried; in one column note the good conductors, and in another column note the insulators and poor conductors.

The water and wet cloth did not ring the bell, but this is because the pressure or voltage of the electricity in the batteries is not very high. In dealing with high-power wires it is much safer to consider water, or anything wet, as a pretty good conductor of electricity. Absolutely pure, distilled water is an extremely poor conductor; but most water has enough minerals dissolved in it to make it conduct electricity fairly well. In your list you had better put water and wet things in the column with the good conductors.

[pg 217]



FIG. 122. Which should he choose to connect the broken wires?

Application 50. Robbers had cut the telegraph line between two railroad stations (Fig. 122). The broken ends of the wire fell to the ground, a number of feet apart. A farmer caught sight of the men speeding away in an automobile and he saw the cut wires on the ground. He guessed that they had some evil purpose and decided to repair the damage. He could not bring the two ends of the wire together. He ran to his barn and found the following things there:

A ball of cord, a pickax, a crowbar, some harness, a wooden wagon tongue, a whip, a piece of iron wire around a bale of hay (the wire was not long enough to stretch the whole distance between the two ends of the telegraph wire, even if you think he might have used it to patch the gap), a barrel with four iron hoops, and a rope.

Which of these things could he have made use of in connecting the broken ends of the telegraph wire?

Application 51. A man was about to put in a new socket for an electric lamp in his home. He did not want to turn off the current for the whole house, as it was night and there was no gas to furnish light while he worked.

"I've heard that if you keep your hands wet while you work, the film of water on them will keep you from getting a shock," his wife said.

"Don't you wet your hands, Father," said his 12-year-old boy; "keep them dry, and handle the wires with your pliers, so that you won't have to touch it."

[pg 218]

"I advise you to put on your canvas gloves while you work; then you can't get a shock," added another member of the family.

"That's a good idea," said the wife, "but wet the gloves, then you will have the double protection of the water and the cloth."

The man laughed and went to work on the socket. He did not get a shock. Which advice, if any, do you think he followed?

Inference Exercise

Explain the following:

311. A red postage stamp looks greenish gray in the green light of a mercury-vapor lamp.

312. Cracks are left between sections of the roadbed in cement auto highways.

313. Electricity goes up a mountain through a wire.

314. It is impossible to stand sidewise against a wall on one foot, when that foot touches the wall.

315. A charged storage battery will run an electric automobile.

[pg 219]

316. An empty house is noisier to walk in and talk in than is a furnished one.

317. Lightning rods are made of metal.

318. It is harder to hold a frying pan by the end of the handle than by part of the handle close to the pan.

319. Diamonds flash many colors.

320. In swimming, if you have hold of a fastened rope and try to pull it toward you, you go toward it.

SECTION 35. *Complete circuits.*

Why does a doorbell ring when you push a button?

Why is it that when you touch one electric wire you feel no shock, while if you touch two wires you sometimes get a shock?

When a wire is broken in an electric light, why does it not light?

Suppose you have some water in an open circular trough like the one shown in Figure 123. Then suppose you have a paddle and keep pushing the water to your right from one point. The water you push pushes the water next to it, that pushes the water next to it, and so on all around the trough until the water just behind your paddle pushes in toward the paddle; the water goes around and around the trough in a complete circuit. There never is too much water in one place; you never run out of water. But then suppose a partition is put across the trough somewhere along the circuit. When the water reaches that, it cannot pass; it has no place to flow to, and the current of water stops.

The electric circuit. The flow of electricity in an electric circuit may be compared to the flow of the water in the tank we have been imagining. The long loop of wire extending out from the dynamo to your house and back again corresponds to the tank. The electricity corresponds to the water. Your dynamo pushes the electricity around and around the circuit, as the paddle pushes the water. But let some one break the circuit by putting a partition between two parts of it, and the electricity immediately stops flowing. One of the most effective partitions we can put into an electric circuit is a gap of air. It is very difficult for any electricity to flow through the air; so if we simply cut the wire in two, electricity can no longer flow from one part to the other, and the current is broken.

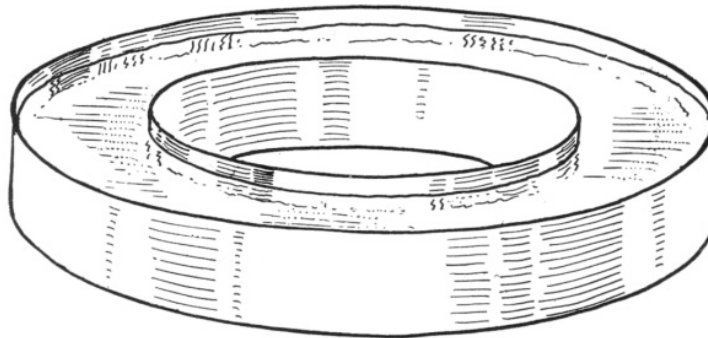

FIG. 123. Electricity flows around a completed circuit somewhat as water might be made to flow around this trough.

Breaking and making the circuit. The most convenient way to put an air partition into an electric circuit and so to break it, or to close the circuit again so it will be complete, is to use a switch.

Experiment 67. In the laboratory, examine the three different kinds of switches where the electricity flows into the lamp and resistance wire and then out again. Trace the path the electricity must take from the wire coming into the building down to the first switch that it meets; then from one end of the wire through the brass or copper to which the wire is screwed, through the switch and on out into the end of the next piece of wire. Turn the first switch off and see how a partition of air is made between the place where the electricity comes in and the place where it would get out if it could. Turn the switch on and notice how this gives the electricity a complete path through to the next piece of wire. In this way follow the circuit on through all the switches to the electric lamp.

If you examine the socket into which the lamp screws and examine the lamp itself, you will see that electricity which goes to the outer part of the socket passes into the rim of the lamp; from here it goes into one end of the filament. It passes through the filament to the other end, which is connected to the little brass disk at the end of the lamp. From this you can see that it goes into the center point of the socket, and then on into the second wire that connects to the socket. Trace the current on back through this other wire until you see where this wire leads toward the dynamo. You should understand that the electric lamp, the switches, the fuses, all things along

the circuit, are simply parts of the long loop from the dynamo, as shown in Figure 124.

[pg 222]

Connecting in parallel. The trouble with Figure 124 is that it is a little too simple. From looking at it you might think that the loop entered only one building. And it might seem that turning off one switch would shut off the electricity all along the line. It would, too, if the circuit were arranged exactly as shown above. To avoid this, and for other reasons, the main loop from the dynamo has branches so that the electricity can go through any or all of them at the same time and so that shutting off one branch will not affect the others. Electricians call this *connecting in parallel*; there are many parallel circuits from one power house.

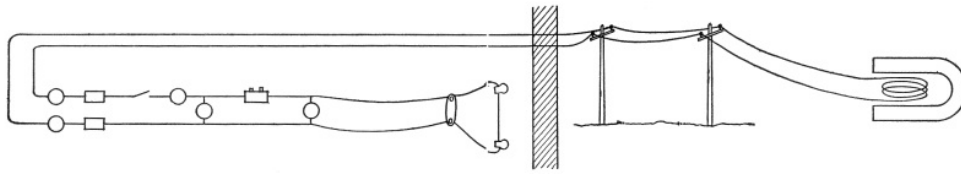

FIG. 124. Diagram of the complete circuit through the laboratory switches.

Figure 125 illustrates the principle just explained. As there diagrammed, the electricity passes out from the dynamo along the lower wire and goes down the left-hand wire of circuit *A* through one of the electric lamps that is turned on, and then it goes back through the right-hand wire of the *A* circuit to the upper wire of the main circuit and then on back to the dynamo. But only a part of the electricity goes through the *A* circuit; part goes on to the *B* circuit, and there it passes partly through the electric iron. Then it goes back through the other wire to the dynamo. No electricity can get through the electric lamp on the *B* circuit, because the switch to the lamp is open. The switch on the *C* circuit is open; so no electricity can pass through it.

[pg 223]

The purpose of the diagram is to show that electricity from the dynamo may go through several branch circuits and then get back to the dynamo, and that shutting off the electricity from one branch circuit does not shut it off from the others. And the purpose of this section is to make it clear that electricity can flow only through a complete circuit; it must have an unbroken path from the dynamo back to the dynamo again or from one pole of the battery back to the other pole. If the electricity does not have a complete circuit, it will not flow.

Application 52. A small boy disconnected the doorbell batteries from the wires that ran to them, and when he wanted to put the wires back, he could not remember how they had been connected. He tried fastening both wires to the carbon part of the battery, connecting one wire to the carbon and one to the zinc, and connecting both to the zinc. Then he decided that one wire was all that had to be connected anyway, that the second was simply to make it stronger. Which of the ways he tried, if any, would have been right?

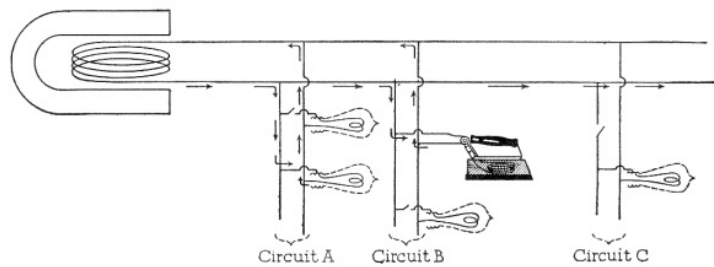

FIG. 125. Parallel circuits.

[pg 224]

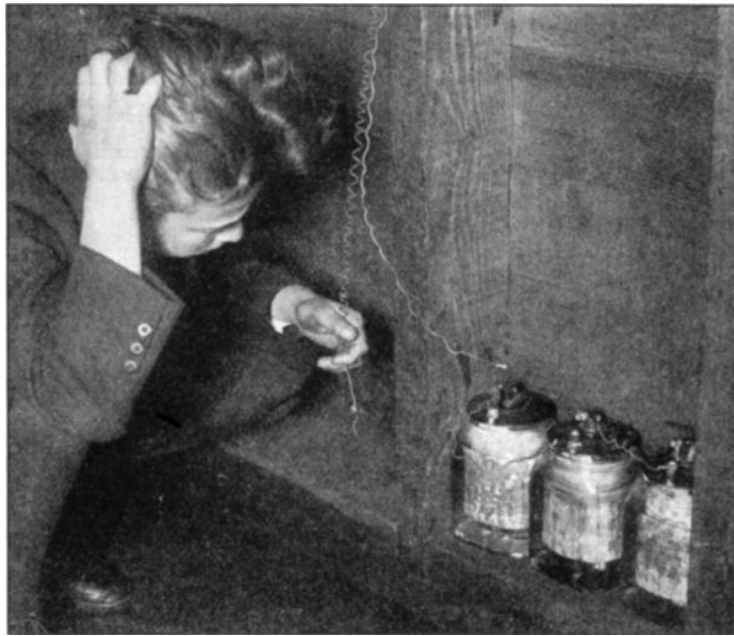

FIG. 126. How should he connect them?

Application 53. Dorothy was moving. "When they took out our telephone," she said to her chum, Helen, "the electrician just cut the wires right off."

"He must have turned off the electricity first," Helen answered, "or else it would all have run out of the cut ends of the wire and gone to waste."

"Why, it couldn't," Dorothy said. "Electricity won't flow off into the air."

"Of course it can if there is nothing to hold it in," Helen argued.

Which was right?

Inference Exercise

Explain the following:

321. It is very easy to get chilled when one is perspiring.
322. Ice cream becomes liquid if you leave it in your dish too long.
323. You should face forward when alighting from a street car.
324. There are always at least two electric wires going into a building that is wired.
325. Woolen sweaters keep you warm.
326. Steel rails are not riveted to railroad ties but the spikes are driven close to each rail so that the heads hook over the edge and hold the rail down without absolutely preventing its movement forward and backward. Why should rails be laid in this way?
327. The earth keeps whirling around the sun without falling into it, although the pull from the sun is very great.
328. Electricity is brought down from power houses in the mountains by means of cables.
329. White clothes are cooler than black when the person wearing them is out in the sun.
330. All the street cars along one line are stopped when a trolley wire breaks.

SECTION 36. *Grounded circuits.*

Why can a bird sit on a live wire without getting a shock, while a man would get a shock if he reached up and took hold of the same wire?

We have just been laying emphasis on the fact that for electricity to flow out of a dynamo or battery, it must have a complete circuit back to the battery or dynamo. Yet only one wire is needed in order to telegraph between two stations. Likewise, a single wire could be made to carry into a building the current for electric lights. This is because the ground can carry

electricity.

[pg 226]

If you make all connections from a battery or dynamo just as for any complete circuit, but use the earth for one wire, the electricity will flow perfectly well (Fig. 127). To connect an electric wire with the earth, the wire must go down deep into the ground and be well packed with earth; but since water pipes go down deep and the earth is already packed around them, the most convenient way to ground a circuit is to connect the wire that should go into the ground with the water pipe. The next experiment, the grounding of a circuit, should be done by the class with the help of the teacher.

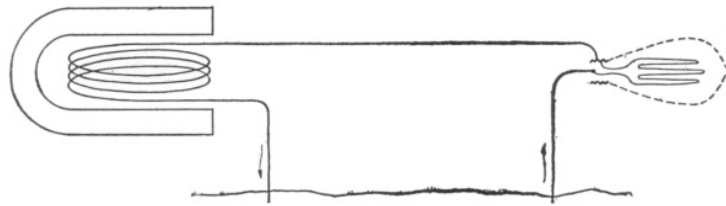

FIG. 127. The ground can be used in place of a wire to complete the circuit.

Experiment 68. *Caution: Keep the switches turned off throughout this experiment.*⁶

Footnote 6: All through this chapter it is assumed that the electrical apparatus described in the appendix is being used. In this apparatus all the switches are on one wire, the other wire being alive even when the switches are turned off.

(a) Put a piece of fuse wire across the fuse gap. Screw the plug with nails in it into the lamp socket. Connect the bare end of a piece of insulated wire to the water faucet and touch the other end to one nail of the plug. If nothing happens, touch it to the other nail instead. The electricity has gone down into the ground through the water pipe, instead of into the other wire. The ground carries the electricity back to the dynamo just as a wire would.

(b) Put a new piece of fuse wire across the gap. *Keep switches turned off.* Touch the brass disk at the bottom of an electric lamp to the nail which worked, and touch the wire from the faucet to the other brass part of the lamp (Fig. 129). What happens?

Caution: Under no circumstances allow the switch to be turned on while you are doing any part of this experiment. Under no circumstances touch the wire from the faucet to the binding posts of the fuse gap. Do only as directed. Explain what would happen if you disobeyed these rules.

[pg 227]



FIG. 128. Grounding the circuit. The faucet and water pipe lead the electricity to the ground.

Why a bird is not electrocuted when it sits on a live wire. If a man accidentally touches a live wire that carries a strong current of electricity he is electrocuted; yet birds perch on such a wire in perfect safety. If a man should leap into the air and grasp a live wire, hanging from it without touching the ground, he would be no more hurt by it than a bird is. A person who is electrocuted by touching such a wire must at the same time be standing on the ground or on something connected with it. The ground completes the electric circuit which passes through the body. An electric circuit can always be completed through the ground, and when this is done, it is called *grounding a circuit*.

[pg 228]

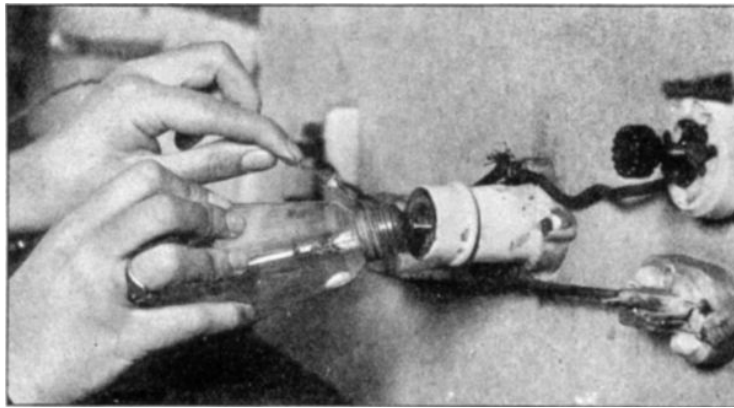

FIG. 129. How the lamp and wire are held to ground the circuit.

Application 54. Explain why only one wire is needed to telegraph between two stations; why you should not turn an electric light on or off while standing in a tub of water.

Application 55. In a house in the country, the electric wires passed through a double wall. They were separated from each other and well covered with insulation, but they were not within an iron pipe, as is now required in many cities. The current was alternating. One night when the lights were out a rat in the wall gnawed through the insulation of the wire and also gnawed clear through one of the wires. Did he get a shock? The next morning, the woman of the house wanted to use the electric iron in the kitchen and it would not work. The kitchen had in it a gas stove, a sink with running water, a table, a couple of chairs, and the usual kitchen utensils. There was also a piece of wire about long enough to reach across the kitchen. The electrician could not come out for several hours, and the woman wanted very much to do her ironing. Figure 130 is a diagram of the wires and the kitchen. Show what the woman might have done in order to use her iron until the electrician arrived.

[pg 229]

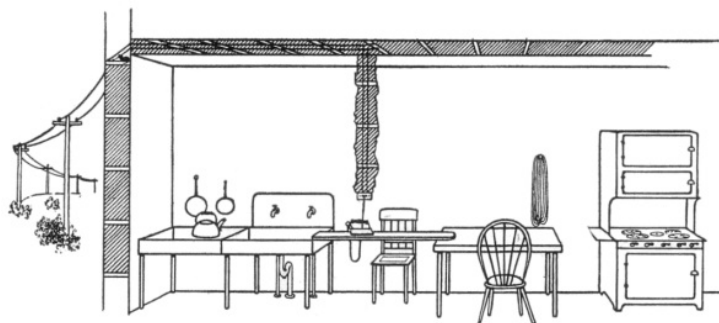

FIG. 130. How can the electric iron be used after one wire has been cut?

Application 56. A man wanted to change the location of the wiring in his cement-floored garage. While he was working, would it have been best for him to stand on the bare cement floor, on a wire mat, on an old automobile tire, on a wet rug, or on some skid chains that were there?

Inference Exercise

Explain the following:

331. An ungreased wheel squeaks.
332. Lightning rods extend into the earth.
333. A banjo player moves his fingers toward the drum end of the banjo when he plays high notes.
334. When the filament breaks, an electric lamp will no longer glow.
335. An inverted image is formed by the lens of a camera.
336. A blown-out fuse may be replaced temporarily with a hairpin or with a copper cent.

337. Sparks fly when a horse's shoe hits a stone.

338. A room requires less artificial light if the wall paper is light than if it is dark.

339. Phonographs usually have horns, either inside or outside.

340. An electric car needs only one wire to make it go.

SECTION 37. *Resistance.*

What makes an electric heater hot?

Why does lightning kill people when it strikes them?

What makes an electric light glow?

[pg 230]

We have talked about making electricity work when it flows in a steady stream, and everybody knows that it makes lights glow, makes toasters and electric stoves hot, and heats electric irons. But did it ever strike you as remarkable that the same electricity that flows harmlessly through the wires in your house without heating them, suddenly makes the wire in your toaster or the filament in your incandescent lamp glowing hot? The insulation is not what keeps the wire cool, as you can see by the next experiment.

Experiment 69. Between two of the laboratory switches you will find one piece of wire which has no insulation. Turn on the electricity and make the lamp glow; see that you are standing on dry wood and are not touching any pipes or anything connected to the ground. Feel the bare piece of wire with your fingers. Why does this not give you a shock? What would happen if you touched your other hand to the gas pipe or water pipe? *Do not try it!* But what would happen if you did?

[pg 231]

The reason that the filament of the electric lamp gets white hot while the copper wire stays cool is this: All substances that conduct electricity resist the flow somewhat; there is something like friction between the wire and the electricity passing through it. The smaller around a wire is, the greater resistance it offers to the passing of an electric current. The filament of an electric lamp is very fine and therefore offers considerable resistance. However, if the filament were made of copper, even as fine as it is, it would take a much greater flow of electricity to make it white hot, and it would be very expensive to use. So filaments are not made of copper but of substances which do not conduct electricity nearly as well and which therefore have much higher resistance. Carbon was once used, but now a metal called *tungsten* is used for most incandescent lamps. Both carbon and tungsten resist an electric current so much that they are easily heated white hot by it. On the other hand, they let so little current through that what does pass flows through the larger copper wires very easily and does not heat them noticeably.

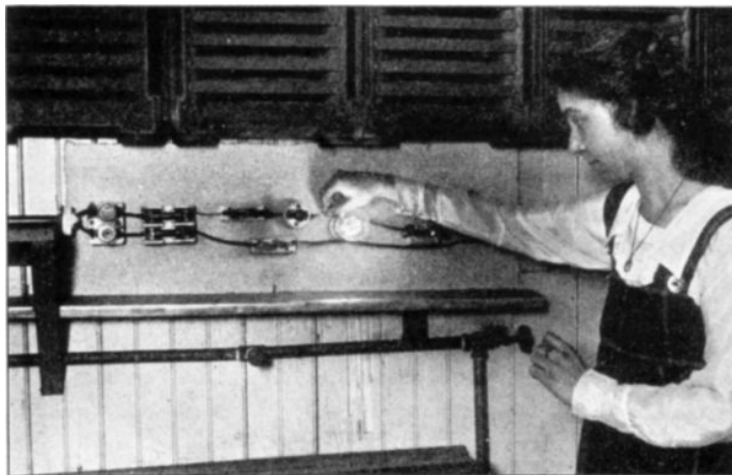

FIG. 131. Feeling one live wire does not give her a shock, but what would happen if she touched the gas pipe with her other hand?

Experiment 70. Turn on the switch that lets the electricity flow through the long resistance wire that passes around the porcelain posts. Watch the wire.

[pg 232]

The resistance wire you are using is an alloy, a mixture of metals that will resist electricity much more than ordinary metals will. This is the same kind of wire that is used in electric irons and toasters and heaters. It has so great a resistance to the electricity that it is heated red hot, or almost white hot, by the electricity passing through it.

Application 57. A power company wanted to send large quantities of electricity down from a mountain. Should the company have obtained resistance wire or copper wire to carry it? Should the wire have been large or fine?

Application 58. A firm was making electric toasters. In the experimental laboratory they tried various weights of resistance wire for the toasters. They tried a very fine wire, No. 30; a medium weight wire, No. 24; and a heavy wire, No. 18. One of these wires did not get hot enough, and it took so much electricity that it would have been too expensive to run; another got so hot that it soon burned out. One worked satisfactorily. Which of the three sizes burned out? Which was satisfactory?

Inference Exercise

Explain the following:

341. If you attach one end of a wire to a water faucet and connect the other end to an electric lamp in place of one of the regular lighting wires, the lamp will light.
342. The needle of a sewing machine goes up and down many times to each stroke of the treadle.
343. Trolley wires are bare.
344. If you had rubbers on your feet, you could take hold of one live wire with perfect safety, provided you touched nothing else.
345. If you were on the moon, you would look up at the earth.
346. Toy balloons burst when they go high up where the air is thin.
347. You have to put on the brakes to stop a car quickly.
348. Telephone wires are strung on glass supporters.
349. If you pour boiling water into a drinking glass, frequently the glass will crack.
350. An asbestos mat tends to keep food from burning.

[pg 233]

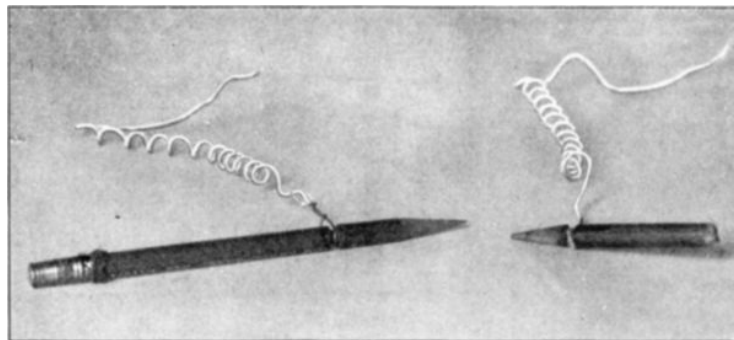

FIG. 132. Pencils ready for making an arc light.

SECTION 38. *The electric arc.*

How can electricity set a house on fire?

This is one of the most important sections in the book.

Do you know that you can make an arc light with two ordinary pencils? The next experiment, which should be done by the class with the help of the teacher, shows how to do it.

Experiment 71. Sharpen two pencils. About halfway between the point and the other end of each pencil cut a notch all the way around and down to the "lead," or burn a notch down by means of the glowing resistance wire. What you call the "lead" of the pencil is really graphite, a form of carbon. The leads of your two pencils are almost exactly like the carbons used in arc lights, except, of course, that they are much smaller. Turn off the electricity both at the snap switch and at the knife switch. Fasten the bare end of a 2-foot piece of fine insulated wire (about No. 24) around the center of the lead in each pencil so that you get a good contact, as shown in Figure 132. Fasten the other bare end of each wire to either side of the open knife switch so that when this switch is open the electricity will have to pass down one wire to the lead of one pencil, from that to the lead of the other pencil, and from that back through the second wire to the other side of the knife switch and on around the circuit, as shown in Figure 133. Keep the two pencils apart and off the desk, while some one turns on the snap switch and the "flush" switch that lets the electricity through the resistance wire. Now bring the pencil points together for an instant, immediately drawing them apart about half an inch. You should get a brilliant white arc light.

[pg 234]

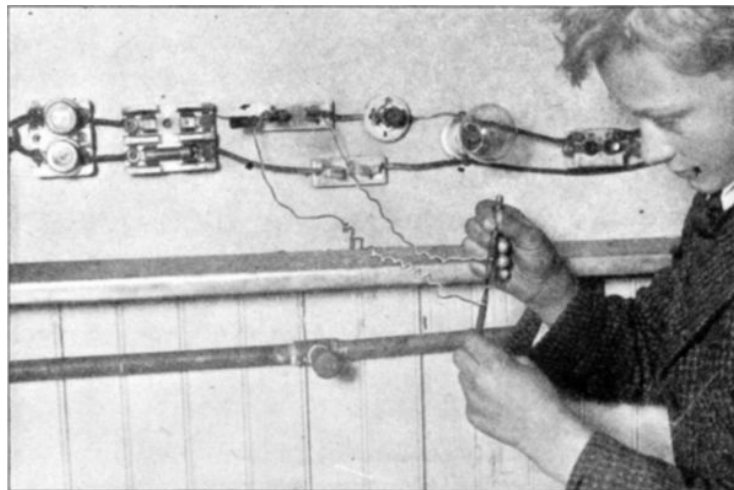

FIG. 133. The pencil points are touched together and immediately drawn apart.

Caution: Do not look at this brilliant arc for more than a fraction of a second unless you look through a piece of smoked or colored glass.

Blow out the flame when the wood catches fire. After you have done this two or three times, the inside of the wood below the notches will be burned out so completely that you can pull it off with your fingers, leaving the lead bare all the way up to the wires.

Let the class stand well back and watch the teacher do the next part of the experiment.

[pg 235]

Connect two heavy insulated copper wires, about No. 12, to the sides of the knife switch just as you connected the fine wires. But this time bring the ends of the copper wires themselves together for an instant, then draw them apart. Hold the ends of the wires over the zinc of the table while you do this, as melted copper will drop from them.



FIG. 134. A brilliant arc light is the result.

What happens when an arc is formed. What happens when you form an electric arc is this: As you draw the two ends of the pencils apart, only a speck of the lead in each touches the other. The electricity passing for an instant through the last speck at the end of the pencil makes it so hot that it turns to vapor. The vapor will let electricity go through it, and makes a bridge from one pencil point to the other. But the vapor gets very hot, because it has a rather high resistance. This heat vaporizes more carbon and makes more vapor for the electricity to pass through, and so on. The electricity passing through the carbon vapor makes it white hot, and that is what causes the brilliant glow. Regular arc lights are made exactly like this experimental one, except that the carbons used are much bigger and are made to stand the heat better than the small carbons in your pencil.

[pg 236]

Carbon is one of those substances that turn directly from a solid to a gas without first melting. That is one reason why it is used for arc lights. But copper melts when it becomes very hot, as you saw when you made an arc light with the copper wires. So copper cannot be used for practical arc lights.

Fires caused by arcs. There is one extremely important point about this experiment with arcs:

most fires that result from defective wiring are caused by the forming of arcs. You see, if two wires touch each other while the current is passing and then move apart a little, an arc is formed. And you have seen how intensely hot such an arc is. Two wires rubbing against each other, or a wire not screwed tightly to its connection, can arc. A wire broken, but with its ends close enough together to touch and then go apart, can cause an arc. And an arc is very dangerous in a house if there is anything burnable near it.

Wires should never be just twisted together and then bound with tape to form a joint. Twisted wires sometimes break and sometimes come loose; then an arc forms, and the house catches fire. Good wiring always means soldering every joint and screwing the ends of the wires tightly into the switches or sockets to which they lead.

[pg 237]

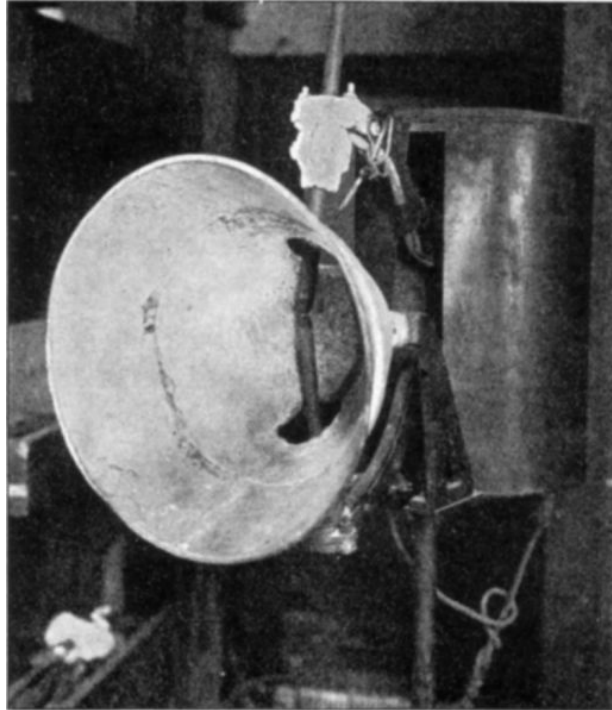

FIG. 135. An arc lamp. The carbons are much larger than the carbons in the pencils, and the arc gives an intense light.

Keeping arcs from forming. Well-wired houses have the wires brought in through iron pipes, called *conduits*, and the conduits are always grounded; so if an arc should form anywhere along the line, the house would be protected by an iron conduit and if one of the loose ends of wire came in contact with the conduit, the current would rush to the ground through it, blowing out a fuse. The next section tells about the purpose of fuses.

[pg 238]

The directions that usually come with electric irons, toasters, and stoves say that the connection should be broken by pulling out the plug rather than by turning off the switch. This is because the switch in the electric-light socket sometimes loses its spring and instead of snapping all the way around and quickly leaving a big gap, it moves only a little way around and an arc is formed in the socket; if you hear a sizzling sound in a socket, you may be pretty sure that an arc has been formed. But when you pull the plug entirely out of the iron or stove, the gap is too big for an arc to form and you are perfectly safe.

Fire commissions usually condemn extension lights, because if the insulation wears out on a lamp cord so that the two wires can come in contact, a dangerous arc may easily form. And the insulation might suddenly be scraped off by something heavy moving across the cord. This can happen whether the light at the end of the cord is turned on or off. So it is best if you have an extension light always to turn it off at the socket from which the cord leads, not at the lamp itself. Many people do not do this, and go for years without having a fire. But so might you live for years with a stick of dynamite in your bureau drawer and never have an explosion. Still, it is not wise to keep dynamite in your bureau.

Arc lights themselves, of course, are no more dangerous than is a fire in a kitchen stove. For an arc light is placed in such a way that nothing can well come near it to catch fire. The danger from the electric arc is like the danger from gasoline spilled and matches dropped where you are not expecting them, so that you are not protected against them.

[pg 239]

Fortunately ordinary batteries have not enough voltage to cause dangerous arcs. So you do not have to be as careful in wiring for electric bells and telegraph instruments. It requires the high voltage of a city power line to make a dangerous electric arc.

So many fires are caused by electric arcs forming in buildings, that you had better go back to the

beginning of this section and read it all through again carefully. It may save your home and even your life.

After you have reread this section, test your understanding of it by answering the following questions:

1. How can you make an electric arc?
2. Why should wires not be twisted together to make electric connections?
3. Why should wires be brought into houses and through walls in iron conduits?
4. Why should you pull out the plug of an electric iron, percolator, toaster, heater, or stove?
5. Why do fire commissions condemn extension lights?
6. If you use an extension light, where should it be turned off?
7. If you hear a sizzling and sputtering in your electric-light socket, what does it mean? What should you do?
8. Is there any danger in defective sockets with switches that do not snap off completely? What is the danger?
9. In Application 55, page [228](#), if the rat had gnawed the wire in two while the electric iron was being used, would anything have happened to the rat? Would there have been any danger to the house?
10. Where a wire is screwed into an electric-light socket, what harm, if any, might result from not screwing it in tightly?
11. How can a wire be safely spliced?
12. Why is an electric arc in a circuit dangerous?

[pg 240]

Inference Exercise

Explain the following:

351. White objects look blue when seen through a blue glass.
352. When you pull the plug out of an electric iron, the iron cools.
353. People who do not hear well sometimes use speaking trumpets.
354. The sounding board of a piano is roughly triangular; the longest strings are the extreme left, and those to the right get shorter and shorter.
355. Birds can sit on live wires without getting a shock.
356. Deaf people can sometimes identify musical selections by holding their hands on the piano.
357. An electric toaster gets hot when a current passes through it.
358. The cord of an electric iron sometimes catches fire while the iron is in use, especially if the cord is old.
359. If a live wire touches the earth or anything connected with it, the current rushes into the earth.
360. When you stub your toe, you have to run forward to keep from falling.

SECTION 39. *Short circuits and fuses.*

Why does a fuse blow out?

Sometimes during the evening when the lights are all on in your home, some one tinkers with a part of the electric circuit or turns on an electric heater or iron, and suddenly all the lights in that part of the house go out. A fuse has blown out. If you have no extra fuses on hand, it may be necessary to wait till the next day to replace the one that is blown out. It is always a good idea to keep a couple of extra fuses; they cost only 10 cents each. And if you do not happen to know how fuses work or how to replace them when they blow out, it will cost a dollar or so to get an electrician to put in a new fuse. The next three experiments will help you to understand fuses.

[pg 241]

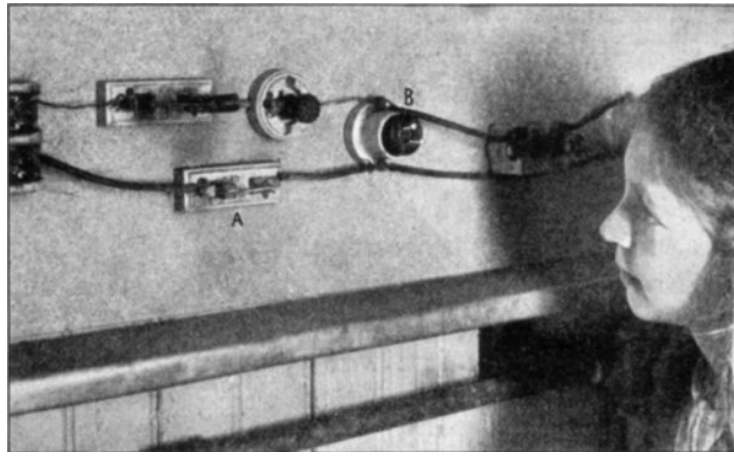

FIG. 136. *A*, the "fuse gap" and *B*, the "nail plug."

Experiment 72. On the lower wire leading to the electric lamp in the laboratory you will find a "gap," a place where the wire ends in a piece of a knife switch, and then begins again about an inch away in another piece of the switch, as shown in Figure 136. There must be some kind of wire or metal that will conduct electricity across this gap. But the gap is there to prevent as much electricity from flowing through as might flow through copper wire. So never put copper wire across this gap. If you do, you will have to pay for the other fuses which may blow out. Always keep a piece of fuse wire stretched across the gap. Fuse wire is a soft leadlike wire, which melts as soon as too much electricity passes through it.

Unscrew the lamp, and into the socket where it was, screw the plug with the two nails sticking out of it. Turn the electricity on. Does anything happen? Turn the electricity off. Now touch the heads of the two nails together, or connect them with a piece of any metal, and turn on the electricity. What happens? Examine the pieces of the fuse wire that are left.

[pg 242]

It was so easy for the electricity to pass through the nails and wire, that it gushed through at a tremendous rate. This melted the fuse wire, or blew out the fuse. If the fuse across the gap by the socket had not been the more easily burned out, one or perhaps both of the more expensive fuses up above, where the wire comes in, would have blown out. These cost about 10 cents each to replace, while the fuse wire you burned out costs only a fraction of a cent. If there were no fuses in the laboratory wirings and you had "short circuited" the electricity (given it an easy enough path), it would have blown out the much more expensive fuses where the electricity enters the building. If there were no big fuses where the electricity enters the building, the rush of electricity would make all the copper wires through which it flowed inside the building so hot that they would melt and set fire to the building. As long as you keep a piece of fuse wire across the gap, there is no danger from short circuits.

Why fuse wire melts. For two reasons, the fuse wire melts when ordinary wire would not. First, it has enough resistance to electricity so that if many amperes (much current) flow through, it gets heated. It has not nearly as much resistance, however, as the filament in an electric lamp or even as has the long resistance wire. It does not become white hot as they do.

Second, it has a low melting point. It melts immediately if you hold a match to it; try this and see. Consequently, long before the fuse wire becomes red hot, it melts in two. It has enough resistance to make it hot as soon as too many amperes flow through; and it has such a low melting point that as soon as it gets hot it melts in two, or blows out. This breaks the circuit, of course, so that no more electricity can flow. In this way the fuse protects houses from catching fire through short circuits.

[pg 243]



FIG. 137. What will happen when the pin is thrust through the cords and the electricity turned on?

Unfortunately, however, the fuse is almost no protection against an electric arc. The copper vapor through which the electricity passes in an arc has enough resistance to keep the amperage (current) low; so the arc may not blow out the fuse at all. But if it were not for fuses, there would be about as much danger of houses being set on fire by short circuits as by arcs. Perhaps there would be more danger, because short circuits are the more common.

[pg 244]

Experiment 73. Put a new piece of fuse wire across the fuse gap. Leave the "nail plug" screwed in the socket. Use a piece of flexible lamp cord—the kind that is made of two strands of wire twisted together (see Fig. 137). Fasten one bared end of each wire around each nail of the "nail plug." See that the other ends of the lamp cord are not touching each other. Turn on the electricity. Does anything happen? Turn off the electricity. Now put a pin straight through the middle of the two wires. Turn on the electricity again. What happens?

There is not much resistance in the pin, and so it allows the electricity to rush through it. People sometimes cause fuses to blow out by pinning pictures to electric lamp wires or by pinning the wires up out of the way.

A short circuit an "easy circuit." You always get a short circuit when you give electricity an easy way to get from one wire to the other. But you get no current unless you give it some way to pass from one wire to the other, thus completing the circuit. Therefore you should always complete the circuit through something which resists the flow of electricity, like an electric lamp, a heater, or an iron. Remember this and you will have the key to an understanding of the practical use of electricity.

The term "short circuit" is a little confusing, in that electricity may have to go a longer way to be short circuited than to pass through some resistance, such as a lamp. Really a short circuit should be called an "easy circuit" or something like that, to indicate that it is the path of least resistance. Wherever the electricity has a chance to complete its circuit without going through any considerable resistance, no matter how *far* it goes, we have a short circuit. And since everything resists electricity a little, a large enough flow of electricity would even heat a *copper* wire red hot; that is why a short circuit would be dangerous if you had no fuses.

[pg 245]

Application 59. To test your knowledge of short circuits and fuses, trace the current carefully from the upper wire as it enters the laboratory, through the plug fuse. Show where it comes from to enter the plug fuse, exactly how it goes through the fuse, where it comes out, and where it goes from there. Trace it on through the cartridge fuse in the same way, through all the switches into the lamp socket, through the lamp, out of the lamp socket to the fuse gap, across this to the other wire, and on out of the room.

It goes on from there through more fuses and back to the dynamo from which the other wire comes.

Test yourself further with the following questions:

1. Where in this circuit is the resistance supposed to be?
2. What happens when you put a good conductor in place of this resistance if the electricity can get from one wire to the other without passing through this resistance?
3. Why do we use fuses?
4. What is a short circuit?
5. What makes an electric toaster get hot?
6. Why should you not stick pins through electric cords?

[pg 246]

Experiment 74. Take the fuse wire out of the fuse gap and put a single strand of zinc shaving in its place. Instead of the nail plug, screw the lamp into the socket. Do not turn on the switch that lets the electricity flow through the resistance wire, but turn on the electricity so that the lamp will glow. Does the zinc shaving work satisfactorily as a fuse wire? Now turn the electricity on through the resistance wire. What happens?

When are the greater number of amperes of electricity flowing through the zinc shaving? (NOTE. "Amperes" means the amount of current flowing.) Can the zinc shaving stand as many amperes as the fuse wire you ordinarily use? Which lets more electricity pass through it, the lamp or the resistance wire? Why do electric irons and toasters often blow out fuses? If this happens at your home, examine the fuse and see how many amperes (how much current) it will allow to flow through it. It will say *6A* if it allows 6 amperes to pass through it; *25A* if it allows 25 amperes to pass through it, etc. The fuse wire across the fuse gap allows about 8 amperes to pass through before it melts. The zinc shaving allows only about 2. Read the marks on the cartridge and plug fuses. How many amperes will they stand?

Application 60. A family had just secured an electric heater. The first night it was used, the fuse blew out.

The boy said: "Let's put a piece of copper wire across the fuse socket; then there can't be any more trouble."

The father said that they had better get a new fuse to replace the old one. The old fuse was marked *10A*.

Was the boy or was the father right? If the father was right, should they have got a fuse marked *6A*, one marked *10A*, or one marked *15A*?

Application 61. The family were putting up an extension light. They wanted the cord held firmly up out of the way. One suggested that they drive a nail through both parts of the cord and into the wall. Another thought it would be better to put a loop of string around the cord and fasten the loop to the wall. A third suggested the use of a double-pointed carpet tack that would go across the wires, but not through them, and if driven tightly into the wall would hold the wire more firmly than would the loop.

[pg 247]

Which way was best?

Inference Exercise

Explain the following:

361. If the insulation wears off both wires of a lamp cord, the fuse will blow out.
362. Street cars are heated by electricity.
363. The handles of pancake turners are often made of wood.
364. Glue soaks into the pores of pieces of wood and gradually hardens.
365. The glue then holds the pieces tightly together.
366. You need a fuse of higher amperage, as a 10-ampere fuse, instead of a 6-ampere one, where you use electricity for an iron, and one of still higher amperage for an electric stove.
367. You should be careful about turning on electric lights or doing anything with electric wires when you are on a cement, iron, or earthen floor, or if you are standing in water.
368. The keys and buttons with which you turn on electric lights are usually made of a rubber composition.
369. Defective wiring, because of which bare wires may touch, has caused many fires.

370. A person wearing glasses can sometimes see in them the image of a person behind him.

SECTION 40. *Electromagnets.*

How is a telegram sent?

What carries your voice when you telephone?

So far we have talked about electricity only making heat and light by being forced through something that resists it. But everybody knows that electricity can be made to do another kind of work. It can be made to move things,—to run street cars, to click telegraph instruments, to vibrate the thin metal disk in a telephone receiver, and so on. The following experiments will show you how electricity moves things:



FIG. 138. The magnetized bolt picks up the iron filings.

Experiment 75. Bare an inch of each end of a piece of insulated wire about 10 feet long. Fasten one end to the zinc of your battery or to one wire from the storage battery; wrap the wire around and around an iron machine bolt, leaving the bolt a foot or so from the battery, until you have only about a foot of wire left. Hold your bolt over some iron filings. Is it a magnet? Now touch the free end of your wire to the carbon of your battery or to the other wire from the storage battery, and hold the bolt over the iron filings. Is it a magnet now?

You have completed the circuit by touching the free end of the wire to the free pole of your battery; so the electricity flows through the wire, around the bolt, and back to the battery.

Disconnect one end of the wire from the battery. You have now broken the circuit, and the electricity can no longer flow around the bolt to magnetize it. See if the bolt will pick up the iron filings any more; it may keep a little of its magnetism even when no electricity is flowing, but the magnetism will be noticeably less. When you disconnect the wire so that the electricity can no longer flow through a complete circuit from its source back to its source again, you are said to *break the circuit*.



FIG. 139. Sending a message with a cigar-box telegraph.

Experiment 76. Examine the cigar-box telegraph (see Appendix B) and notice that it is made on the same principle as was the magnetized bolt in Experiment 75. Complete the circuit through the electromagnet (the bolt wound with wire) by connecting the two ends of the wire that is wrapped around the bolt, with wires from the two poles of the battery. By making and breaking the circuit (connecting and disconnecting one of the wires) you should be able to make the lower bolt jump up and down and give the characteristic click of the telegraph instrument.

[pg 250]



FIG. 140. Connecting up a real telegraph instrument.

In this experiment it does not matter how long the wires are if the batteries are strong enough. Of course it makes no difference where you break the circuit. So you could have the batteries in the laboratory and the cigar box a hundred miles away, with the wire going from the batteries to the bolt and back again. Then if you made and broke the circuit at the laboratory, the instrument would click a hundred miles away. If you want to, you may take the cigar-box telegraph out into the yard, leaving the batteries in the laboratory, while you try to telegraph this short distance.

Examine a regular telegraph instrument. Trace the wire from one binding post, around the coil and through the key, back to the other binding post, and notice how pushing down the key completes the circuit and how raising it up breaks the circuit.

Experiment 77. Connect two regular telegraph instruments, leaving one at each end of the long laboratory table. Make the connections as follows:

[pg 251]

Take a wire long enough to go from one instrument to the other. Fasten the bare ends of this wire into the right-hand binding post of the instrument at your left, and into the left-hand binding post of the instrument at your right; that is, connect the binding posts that are nearest together, as in Figure 141.

Now connect one wire from the laboratory battery to the free post of the right-hand instrument. Connect the other wire from the laboratory battery to the ground through a

faucet, radiator, or gas pipe, making the connection firm and being sure that there is a good, clear contact between the bare end of the wire and the metal to which the wire is attached.

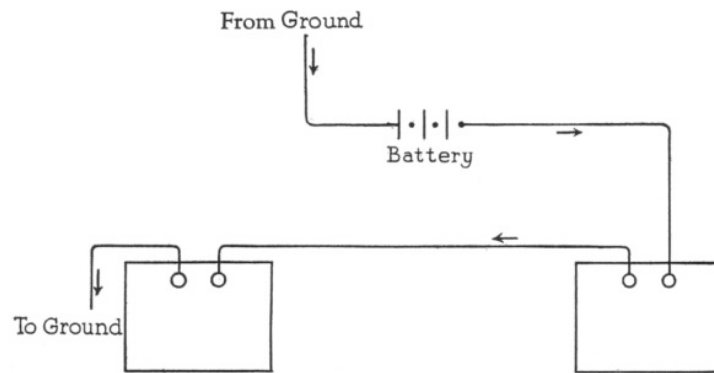

FIG. 141. Diagram showing how to connect up two telegraph instruments. The circles on the tables represent the binding posts of the instruments.

Make another ground connection near the left-hand instrument; that is, take a wire long enough to reach from some pipe or radiator to the left-hand telegraph instrument, bind one bare end of this wire firmly to a clean part of the pipe and bring the other end toward the instrument. Before attaching this other end to the free binding post of the left-hand instrument, be sure to open the switch beside the telegraph key by pushing it to your right. Close the switch on the other instrument. Now attach the free ground wire to the free binding post of your telegraph instrument, and press the key. Does the other instrument click? If not, disconnect the ground wire and examine all connections. Also press the sounder of each instrument down and see if it springs back readily. It may be that some screw is too tight, or too loose, or that a spring has come off; tinker awhile and see if you cannot make the instrument work. If you are unable to do so, ask for help.

[pg 252]

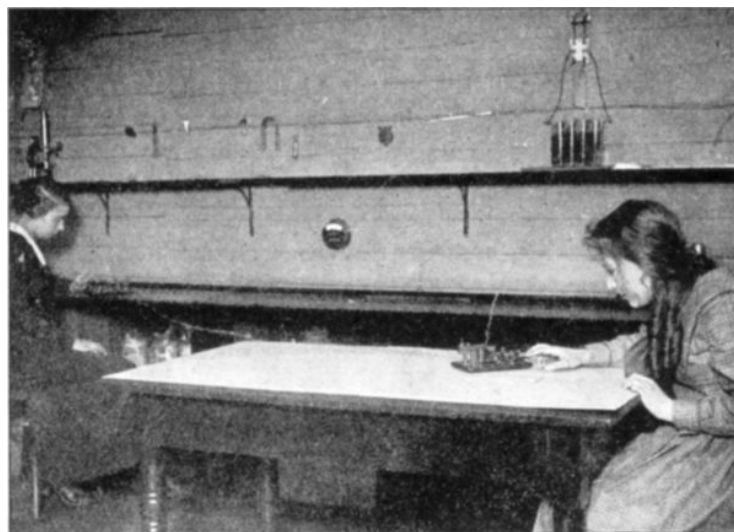

FIG. 142. Telegraphing across the room.

Figure 141 is a diagram of all the connections.

When you want to telegraph, open the switch of the instrument you want to send from and close the switch of the instrument which is to receive the message.

Holding the key down a little while, then letting it up, makes a "dash," while letting it spring up instantly, makes a "dot."

Practice making dots and dashes. Telegraph the word "cat," using the alphabet shown on the next page. Telegraph your own name; your address.

[pg 253]

Here is the Morse telegraph code in dots and dashes:

LETTERS

A	B	C	D	E	F	G
— — — — —	— — — — —	— — — — —	— — — — —	— — — — —	— — — — —	— — — — —
H	I	J	K	L	M	N
— — — — —	— — — — —	— — — — —	— — — — —	— — — — —	— — — — —	— — — — —
O	P	Q	R	S	T	U
— — — — —	— — — — —	— — — — —	— — — — —	— — — — —	— — — — —	— — — — —
V	W	X	Y	Z	&	
— — — — —	— — — — —	— — — — —	— — — — —	— — — — —	— — — — —	

NUMERALS

1	2	3	4	5
— — — — —	— — — — —	— — — — —	— — — — —	— — — — —
6	7	8	9	0
— — — — —	— — — — —	— — — — —	— — — — —	— — — — —

By using the Morse code, telegraph and cable messages are sent all over the world in a few seconds. The ability to send messages in this way arose from the simple discovery that when an electric current passes around a piece of iron, it turns the iron into a magnet.

How a telephone works. A telephone is much like a delicate and complicated telegraph in which the vibrations started by your voice press the "key," and in which the sounder can vibrate swiftly in response to the electric currents passing through the wire. The "key" in the telephone is a thin metal disk that vibrates easily, back of the rubber mouthpiece. Each time an air vibration from your voice presses against it, it increases the current flowing in the circuit. And each time the current in the circuit is increased, the disk in the receiver is pulled down, just as the sounder of a telegraph is pulled down. So every vibration of the disk back of the mouthpiece causes a vibration of the disk in the receiver of the other telephone; this makes the air over it vibrate just as your voice made the mouthpiece vibrate, and you get the same sound.

[pg 254]

To make a difference between slight vibrations and larger ones in telephones, there are some carbon granules between the mouthpiece disk and a disk behind it; and there are various other complications, such as the bell-ringing apparatus and the connections in the central office. But the principle of the telephone is almost exactly the same as the principle of the telegraph. Both depend entirely on the fact that an electric current passing around a piece of iron magnetizes the iron.

Experiment 78. By means of your battery, make an electric bell ring. Examine the bell and trace the current through it. Notice how the current passes around two iron bars and magnetizes them, as it did in the telegraph instrument. Notice that the circuit is completed through a little metal attachment on the base of the clapper, and that when the clapper is pulled toward the electromagnet the circuit is broken. The iron bars are then no longer magnetized. Notice that a spring pulls the clapper back into place as soon as the iron stops attracting it. This completes the circuit again and the clapper is pulled down. That breaks the circuit and the clapper springs back. See how this constant making and breaking of the circuit causes the bell clapper to fly back and forth.

[pg 255]

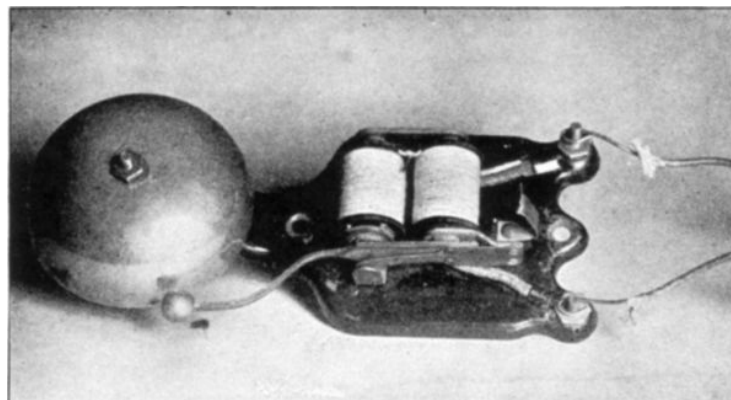

FIG. 143. The bell is rung by electromagnets.

The electric bell, like the telephone and telegraph, works on the simple principle that electricity flowing through a wire that is wrapped around and around a piece of iron will turn that piece of iron into a magnet as long as the electricity flows.

The electric motor. The motor of a street car is a still more complicated carrying out of the same principle. In the next experiment you will see the working of a motor.

Experiment 79. Connect the wires from the laboratory battery to the two binding posts of the toy motor, and make the motor run. Examine the motor and see that it is made of several electromagnets which keep attracting each other around and around.

Motors, and therefore all things that are *moved* by electricity, including trolley cars and electric railways, submarines while submerged, electric automobiles, electric sewing machines, electric vacuum cleaners, and electric player-pianos, are moved by magnetizing a piece of iron and letting this pull on another piece of iron. And the iron is magnetized by letting a current of electricity flow around and around it.

[pg 256]



FIG. 144. A toy electric motor that goes.

The making of various kinds of electromagnets and putting currents of electricity to work is becoming one of the great industries of mankind. Waterfalls are being hitched up to dynamos everywhere, and the water power that once turned the mill wheels now turns millions of coils of wire between the poles of powerful magnets. The current generated in this way is used for all kinds of work—not only for furnishing light to cities, and cooking meals, heating homes, and ironing clothes, but for running powerful motors in factories, for driving interurban trains swiftly across the country, for carrying people back and forth to work in city street cars, for lifting great pieces of iron and steel in the yards where huge electromagnets are used,—for countless pieces of work in all parts of the globe. Yet the use of electricity is still only in its beginning. Tremendous amounts of water power are still running to waste; there is almost no limit to the amount of electricity we shall be able to generate as we use the world's water power to turn our dynamos.

[pg 257]

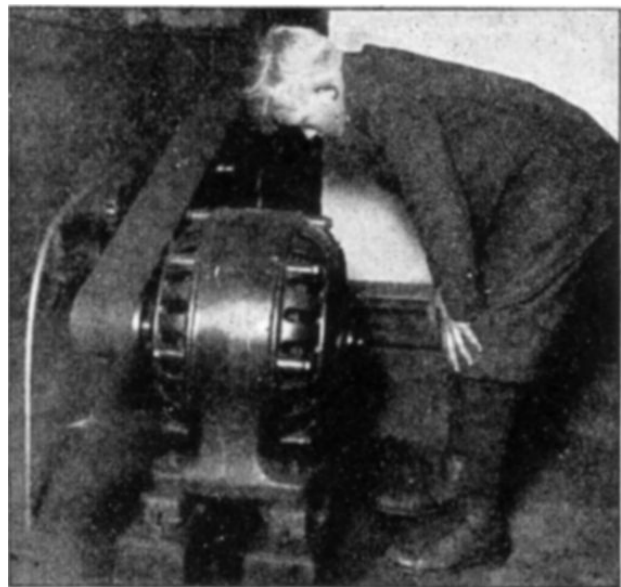

FIG. 145. An electric motor of commercial size.

Application 62. Explain how pressing a telegraph key can make another instrument click hundreds of miles away, and how you can hear over the telephone. Is it vibrations of sound or of electricity that go through the telephone wire, or does your voice travel

over it, or does the wire itself vibrate? Explain how electricity can make a car go.

Inference Exercise

Explain the following:

371. When a fuse blows out, you can get no light.

372. If you lay your ear on a desk, you hear the sounds in the room clearly.

373. If you touch a live wire with wet hands, you get a much worse shock than if you touch it with dry hands.

374. A park music stand is backed by a sounding board.

375. The clapper of an electric bell is pulled against the bell when you push the button.

376. A hot iron tire put on a wagon wheel fits very tightly when it cools.

[pg 258]

377. Candy will cool more rapidly in a tin plate than in a china plate.

378. When a trolley wire breaks and falls to the ground it melts and burns at the point at which it touches the ground.

379. By allowing the electricity from the trolley wire to flow down through an underground coil of wire, a motorman can open a switch in the track.

380. The bare ends of the two wires leading to your electric lamp should never be allowed to touch each other.

[pg 259]

CHAPTER NINE

MINGLING OF MOLECULES

SECTION 41. *Solutions and emulsions.*

How does soap make your hands clean?

Why will gasoline take a grease spot out of your clothes?

If we were to go back to our convenient imaginary switchboard to turn off another law, we should find near the heat switches, and not far from the chemistry ones, a switch labeled SOLUTION. Suppose we turned it off:

The fishes in the sea are among the first creatures to be surprised by our action. For instantly all the salt in the ocean drops to the bottom like so much sand, and most salt-water fishes soon perish in the fresh water.

If some one is about to drink a cup of tea and has sweetened it just to his taste, you can imagine his amazement when, bringing it to his lips, he finds himself drinking tasteless, white, milky water. Down in the bottom of the cup is a sediment of sugar, like so much fine gravel, with a brownish dust of tea covering it.

To see whether or not the trouble is with the sugar itself, he may take some sugar out of the bowl and taste it,—it is just like white sand. Wondering what has happened, and whether he or the sugar is at fault, he reaches for the vinegar cruet. The vinegar is no longer clear, but is a colorless liquid with tiny specks of brown floating about in it. Tasting it, he thinks it must be dusty water. Salt, pepper, mustard, onions, or anything he eats, is absolutely tasteless, although some of the things *smell* as strong as ever.

[pg 260]

To tell the truth, I doubt if the man has a chance to do all of this experimenting. For the salt in his blood turns to solid hard grains, and the dissolved food in the blood turns to dustlike particles. His blood flows through him, a muddy stream of sterile water. The cells of his body get no food, and even before they miss the food, most of the cells shrivel to drops of muddy water. The whole man collapses.

Plants are as badly off. The life-giving sap turns to water with specks of the one-time nourishment floating uselessly through it. Most plant cells, like the cells in the man, turn to water, with fibers and dust flecks making it cloudy. Within a few seconds there is not a living thing left in the world, and the saltless waves dash up on a barren shore.

Probably we had better let the SOLUTION switch alone, after all. Instead, here are a couple of experiments that will help to make clear what happens when anything dissolves to make a *solution*.

Experiment 80. Fill a test tube one fourth full of cold water. Slowly stir in salt until no more will dissolve. Add half a teaspoonful more of salt than will dissolve. Dry the

outside of the test tube and heat the salty water over the Bunsen burner. Will hot water dissolve things more readily or less readily than cold? Why do you wash dishes in hot water?

Experiment 81. Fill a test tube one fourth full of any kind of oil, and one fourth full of water. Hold your thumb over the top of the test tube and shake it hard for a minute or two. Now look at it. Pour it out, and shake some prepared cleanser into the test tube, adding a little more water. Shake the test tube thoroughly and rinse. Put it away clean.

[pg 261]

When you shake the oil with the water, the oil breaks up into tiny droplets. These droplets are so small that they reflect the light that strikes them and so look white, or pale yellow. This milky mixture is called an *emulsion*. Milk is an emulsion; there are tiny droplets of butter fat and other substances scattered all through the milk. The butter fat is *not* dissolved in the rest of the milk, and the oil is *not* dissolved in the water. But the droplets may be so small that an emulsion acts almost exactly like a solution.



FIG. 146. Will heating the water make more salt dissolve?

But when you shake or stir salt or sugar in water, the particles divide up into smaller and smaller pieces, until probably each piece is just a single molecule of the salt or sugar. And these molecules get into the spaces between the water molecules and bounce around among them. They therefore act like the water and let the light through. This is a solution. The salt or sugar is *dissolved* in the water. Any liquid mixture which remains clear is a solution, no matter what the color. Most red ink, most blueing, clear coffee, tea, and ocean water are solutions. If a liquid is *clear*, no matter what the color, you can be sure that whatever things may be in it are dissolved.

[pg 262]

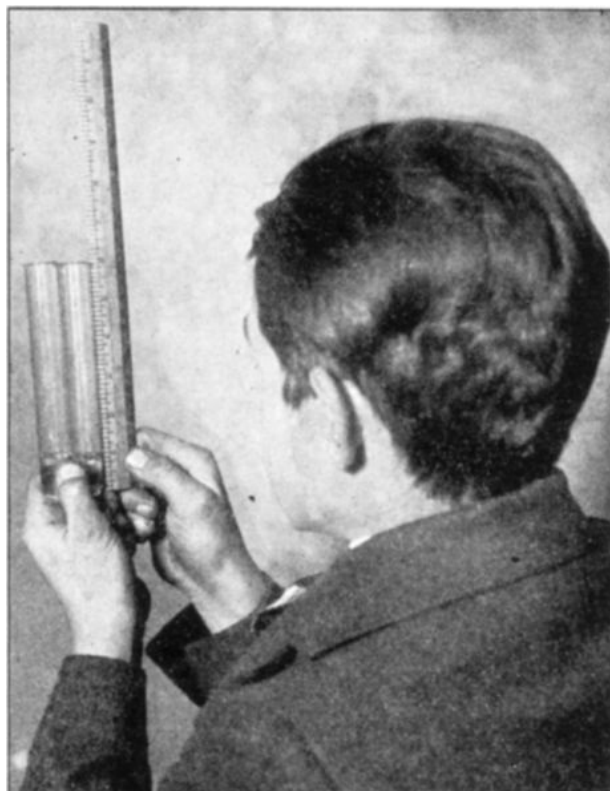

FIG. 147. Will the volume be doubled when the alcohol and water are poured together?

Experiment 82. Pour alcohol into a test tube (square-bottomed test tubes are best for this experiment), standing the tube up beside a ruler. When the alcohol is just 1 inch high in the tube, stop pouring. Put exactly the same amount of water in another test tube of the same size. When you pour them together, how many inches high do you

think the mixture will be? Pour the water into the alcohol, shake the mixture a little, and measure to see how high it comes in the test tube. Did you notice the warmth when you shook the tube?

[pg 263]

If you use denatured alcohol, you are likely to have an emulsion as a result of the mixing. The *alcohol* part of the denatured alcohol dissolves in the water well enough, but the *denaturing* substance *in* the alcohol will not dissolve in water; so it forms tiny droplets that make the mixture of alcohol and water cloudy.

The purpose of this experiment is to show that the molecules of water get into the spaces between the molecules of alcohol. It is as if you were to add a pail of pebbles to a pail of apples. The pebbles would fill in between the apples, and the mixture would not nearly fill two pails.

The most important difference between a solution and an emulsion is that the particles in an emulsion are very much larger than those in a solution; but for practical purposes that often does not make much difference. You dissolve a grease spot from your clothes with gasoline; you make an emulsion when you take it off with soap and water; but by either method you remove the spot. You dissolve part of the coffee or tea in boiling water; you make an emulsion with cocoa; but in both cases the flavor is distributed through the liquid. Milk is an emulsion, vinegar is a solution; but in both, the particles are so thoroughly mixed with the water that the flavor is the same throughout. Therefore in working out inferences that are explained in terms of solutions and emulsions, it is not especially important for you to decide whether you have a solution or an emulsion if you know that it is one or the other.

[pg 264]

How precious stones are formed. Colored glass is made by dissolving coloring matter in the glass while it is molten. Rubies, sapphires, emeralds, topazes, and amethysts were colored in the same way, but by nature. When the part of the earth where they are found was hot enough to melt stone, the liquid ruby or sapphire or emerald, or whatever the stone was to be, happened to be near some coloring matter that dissolved in it and gave it color. Several of these stones are made of exactly the same kind of material, but different kinds of coloring matter dissolved in them when they were melted.

Many articles are much used chiefly because they are good *emulsifiers* or good *solvents* (dissolve things well). Soap is a first-rate emulsifier; water is the best solvent in the world; but it will not dissolve oil and gummy things sufficiently to be of use when we want them dissolved. Turpentine, alcohol, and gasoline find one of their chief uses as solvents for gums and oils. Almost all cleaning is simply a process of dissolving or emulsifying the dirt you want to get rid of, and washing it away with the liquid. Do not forget that heat helps to dissolve most things.

Application 63. Explain why clothes are washed in hot suds; why sugar disappears in hot coffee or tea; why it does not disappear as quickly in cold lemonade; why you cannot see through milk as you can through water.

Inference Exercise

Explain the following:

381. A kind of lamp bracket is made with a rubber cup. When you press this cup against the wall or against a piece of furniture and exhaust the air from the cup, the cup sticks fast to the wall and supports the lamp bracket.

382. You can take a vaseline stain out with kerosene.

383. If the two poles of an electric battery are connected with a copper wire, the battery soon becomes discharged.

384. Electric bells have iron bars wound around and around with insulated copper wire.

[pg 265]

385. Piano keys may be cleaned with alcohol.

386. Linemen working with live wires wear heavy rubber gloves.

387. Crayon will not write on the smooth, glazed parts of a blackboard.

388. Varnish and shellac may be thinned with alcohol.

389. Filtering will take mud out of water, but it will not remove salt.

390. Explain why only one wire is needed to telegraph between two stations.

SECTION 42. *Crystals.*

How is rock candy made?

Why is there sugar around the mouth of a syrup jug?

How are jewels formed in the earth?

You can learn how crystals are formed—and many gems and rock candy and the sugar on a syrup jug are all crystals—by making some. Try this experiment:

Experiment 83. Fill a test tube one fourth full of powdered alum; cover the alum with boiling water; hold the tube over a flame so that the mixture will boil gently; and slowly add boiling-hot water until all of the alum is dissolved. Do not add any more water than you have to, and keep stirring the alum with a glass rod while you are adding the water. Pour half of the solution into another test tube for the next experiment. Hang a string in the first test tube so that it touches the bottom of the tube. Set it aside to cool, uncovered. The next day examine the string and the bottom of the tube.

Experiment 84. While the solution of alum in the second test tube (Experiment 83) is still hot, hold the tube in a pan of cold water and shake or stir it until it cools. When white specks appear in the clear solution, pour off as much of the clear part of the liquid as you can; then pour a little of the rest on a glass slide, and examine the specks under a microscope.

[pg 266]



FIG. 148. Alum crystals.

In both of the above experiments, the hot water was able to dissolve more of the alum than the cold water could possibly hold. So when the water cooled it could no longer hold the alum in solution. Therefore part of the alum turned to solid particles.

When the string was in the cooling liquid, it attracted the particles of alum as they crystallized out of the solution. The force of adhesion drew the near-by molecules to the string, then these drew the next, and these drew more, and so on until the crystals were formed. But when you kept stirring the liquid while it cooled, the crystals never had time to grow large before they were jostled around to some other part of the liquid or were broken by your stirring rod. Therefore they were small instead of large. Stirring or shaking a solution will always make crystals form more quickly, but it will also make them smaller.

[pg 267]

How rock candy is made. Rock candy is made by hanging a string in a strong sugar solution or syrup and letting the water evaporate slowly until there is not enough water to hold all the sugar in solution. Then the sugar crystals gather slowly around the string, forming the large, clear pieces of rock candy. The sugar around the mouth of a syrup jug is formed in the same way.

You always get crystallization when you make a liquid too cool to hold the solid thing in solution, or when you evaporate so much of the liquid that there is not enough left to keep the solid thing dissolved.

When you make fudge, the sugar forms small crystals as the liquid cools. When a boat has been on the ocean, salt crystals form on the sails when the spray that has wet them evaporates.

But crystals may form also in the air. There is always some moisture in the air, and when it becomes very cold, some of this moisture forms crystals of ice. If they form up in the clouds, they fall as snow. If they form around blades of grass or on the sidewalk, as the alum crystals formed on the string, we have frost.

Still another place that crystals occur is in the earth. When the rocks in the earth were hot enough to be melted and then began to cool, certain substances in the rocks crystallized. Some of these crystals that are especially hard and clear constitute precious and semi-precious stones.

[pg 268]

Application 64. Explain why you beat fudge as it cools; why the paper around butter becomes encrusted with salt if it is exposed to the air for some time.

Inference Exercise

Explain the following:

391. Dynamos have *copper* brushes to lead the current from the coils of wire to the line wires.
392. A megaphone makes the voice carry farther than usual.
393. Copper wire is used to conduct electricity, although iron wire costs much less.
394. A flute gives notes that differ in pitch according to the stops that are opened.
395. There are usually solid pieces of sugar around the mouth of a syrup jar.
396. You can beat eggs quickly with a Dover egg beater.
397. When ocean water stands in shallow open tanks for some time, salt begins to form before the water has all evaporated.
398. In a coffee percolator the boiling water goes up through a tube. As this water drips back through the ground coffee beans, it becomes brown and flavored, and the coffee is made.
399. Kerosene will clean off the rim of soap and grease that forms in bathtubs.
400. Beating cake frosting or candy causes it to sugar.

SECTION 43. *Diffusion.*

How does food get into the blood?

Why can you so quickly smell gas that is escaping at the opposite side of a room?

On our imaginary switchboard the DIFFUSION switch would not be safe to tamper with. It would be near the SOLUTION switch, and almost as dangerous. For if you were to make diffusion cease in the world, the dissolved food and oxygen in your blood would do no good; it could not get out of the blood vessels or into the cells of your body. You might breathe all you liked, but breathing would not help you; the air could not get through the walls of your lungs into the blood. Plants would begin to wither and droop, although they would not die quite as quickly as animals and fishes and people. But no sap could enter their roots and none could pass from cell to cell. The plants would be as little able to breathe through their leaves as we through our lungs.

If gas escaped in the room where you were, you could not smell it even if you stayed alive long enough to try; the gas would rise to the top of the room and stay there. All gases and all liquids would stay as they were, and neither would ever form mixtures.

It would not make so much difference in the dead parts of the world if diffusion ceased; the rocks, mountains, earth, and sea would not be changed at all at first. To be sure, the rivers where they flowed into the oceans would make big spaces of saltless water; and when water evaporated from the ocean the vapor would push aside the air and stay in a layer over the ocean, instead of mixing with the air and rising to great heights. But the real disaster would be to living things. All of them would be smothered and starved to death as soon as diffusion ceased.

Here is an experiment that shows how gases diffuse:

Experiment 85. Take two test tubes with mouths of the same size so that you can fit them snugly against each other when you want to. Fill one to the brim with water and hold your thumb or a piece of cardboard over its mouth while you place it upside down in a pan of water. Take the free end of a rubber tube that is attached to a gas pipe and put it into the test tube a short distance, so that the gas will go up into the tube, as shown in Figure 149. Now turn on the gas gently. When all the water has been forced out of the tube and the gas bubbles begin to come up on the outside, turn off the gas. Put a piece of cardboard, about an inch or so square, over the mouth of the tube so that no air can get into it, and take the tube out of the water, *keeping the mouth down and covered*. Bring the empty test tube, which of course is full of air, mouth up under the test tube full of gas, making the mouths of the two tubes meet with the cardboard between them, as shown in Figure 150. Now have some one pull the cardboard gently from between the two test tubes, so that the mouths of the tubes will be pressed against each other and so that practically no gas will escape. Hold them quietly this way, the tube of gas uppermost, for not less than one full minute by the clock. A minute and a half is not too much time. Now have some one light a match for you, or else go to a lighted Bunsen burner.

[pg 269]

[pg 270]

[pg 271]



FIG. 149. Filling a test tube with gas.



FIG. 150. The lower test tube is full of air; the upper, of gas. What will happen when the cardboard is withdrawn?

Take the test tubes apart gently and hold the lower one, which was full of air, with its mouth to the flame. What has the gas in the upper tube done? Now hold the flame to the upper test tube, which was full of gas. What happens? Has all the gas gone out of it?

As you well know, gas is much lighter than air; you can make a balloon rise by filling it with gas. Yet part of the gas went *down* into the lower tube. The explanation is that the molecules of gas and those of air were flying around at such a rate that many of the gas molecules went shooting down among the air molecules, and many of the molecules of air went shooting up among those of gas, so that the gas and the air became mixed.

[pg 272]

Diffusion in liquids. Diffusion takes place in liquids, as you know. For when you put sugar in coffee or tea and do *not* stir it, although the upper part of the tea or coffee is not sweetened, the part nearer the sugar is very sweet. If you should let the coffee or tea, with the sugar in the bottom, stand for a few months, it would get sweet all through. Diffusion is slower in liquids than in gases, because the molecules are so very much closer together.

Osmosis. One of the most striking and important facts about diffusion is that it can take place right through a membrane. Try this experiment:

Experiment 86. With a rubber band fasten a piece of parchment paper, made into a little bag, to the end of a piece of glass tubing about 10 inches long. Or make a small hole in one end of a raw egg and empty the shell; then, to get the hard part off the shell, soak it overnight in strong vinegar or hydrochloric acid diluted about 1 to 4. This will leave a membranous bag that can be used in place of the parchment bag. Fill a tumbler half full of water colored with red ink, and add enough cornstarch to make the water milky. Pour into the tube enough of a strong sugar solution to fill the membranous bag at its base and to rise half an inch in the tube. Put the membranous bag down into the pink, milky water, supporting the tube by passing it through a square cardboard and clamping it with a spring clothespin as shown in Figure 151. Every few minutes look to see what is happening. Does any of the red ink pass through the membrane? Does any of the cornstarch pass through?

This is an example of diffusion through a membrane. The process is called *osmosis*, and the pressure that forces the liquid up the tube is called *osmotic pressure*. It is by this sort of diffusion that chicks which are being incubated get air, and that growing plants get food. It is in this way that the cells of our body secure food and oxygen and get rid of their wastes. There are no little holes in our blood vessels to let the air get into them from our lungs. The air simply diffuses through the thin walls of the blood vessels. There are no holes from the intestinal tract into the blood vessels. Yet the dissolved food diffuses right through the intestinal wall and through the walls of the blood vessels. And later on, when it reaches the body cells that need nourishment, the dissolved food diffuses out through the walls of the blood vessels again and through the cell walls into the cells. Waste is taken out of the cells into the blood and passes from the blood into the lungs and kidneys by this same process of diffusion. So you can readily see why everything would die if diffusion stopped.



FIG. 151. Pouring the syrup into the "osmosis tube."

Application 65. Explain how the roots of a plant can take in water and food when there are no holes from the outside of the root to the inside; how bees can smell flowers for a considerable distance.

Inference Exercise

Explain the following:

401. A shell in the bottom of a teakettle gathers most of the scale around it and so keeps the scale from caking at the bottom of the kettle.

402. There is oxygen dissolved in water. When the water comes in contact with the fine blood vessels in a fish's gills, some of this oxygen passes through the walls of the blood vessels into the blood. Explain how it does so.

403. Asphalt becomes soft in summer.

404. When the trolley comes off the wire the car soon stops.

405. You cannot see stars in the daytime on earth, yet you could see them in the daytime on the airless moon.

406. Although the carbon dioxide you breathe out is heavier than the rest of the air, part of it goes up and mixes with the air above.

407. On a cold day wood does not feel as cold as iron.

408. To make mayonnaise dressing, the oil, egg, and vinegar are thoroughly beaten together.

409. A solution of iodine becomes stronger if it is allowed to stand open to the air.

410. A drop of milk in a glass of water clouds all the water slightly.

Why is it that you can see your breath on a cold day?

Where do rain and snow come from?

What makes the clouds?

[pg 275]

There is water vapor in the air all around us—invisible water vapor, its molecules mingling with those of the air—water that has evaporated from the oceans and lakes and all wet places.

This water vapor changes into droplets of water when it gets cool enough. And those droplets of water make up our clouds and fogs; they join together to form our rain and snow high in the air, or gather as dew or frost on the grass at night.

If the water vapor should suddenly lose its power of changing into droplets of water when it cooled,—well, let us pretend it has lost this power but that any amount of water can evaporate, and see what happens:

What fine weather it is! There is not a cloud in the sky. As evening closes in, the stars come out with intense brightness. The whole sky is gleaming with stars—more than we have ever seen at night before.

The next morning we find no dew or frost on the grass. All the green things look dry. As the day goes on, they begin to wilt and wither. We all wish the day were not quite so fine—a little rain would help things wonderfully. Not a cloud appears, however, and we water as much of our gardens as we can. They drink the water greedily, and that night, again no dew or fog, and not the faintest cloud or mist to dim the stars. And the new day once more brings the blazing sun further to parch the land and plants. Day after day and night after night the drought gets worse. The rivers sink low; brooks run dry; the edges of the lakes become marshes. The marshes dry out to hardened mud. The dry leaves of the trees rustle and crumble. All the animals and wood creatures gather around the muddy pools that once were lakes or rivers. People begin saving water and buying it and selling it as the most precious of articles.

[pg 276]

As the months go by, winter freezes the few pools that remain. No snow falls. Living creatures die by the tens of thousands. But the winter is less cold than usual, because there is now so much water vapor in the air that it acts like a great blanket holding in the earth's heat.

With spring no showers come. The dead trees send forth no buds. No birds herald the coming of warm weather. The continents of the world have become vast, uninhabitable deserts. People have all moved to the shores of the ocean, where their chemists are extracting salt from the water in order to give them something to drink. By using this saltless water they can irrigate the land near the oceans and grow some food to live on. Each continent is encircled by a strip of irrigated land and densely populated cities close to the water's edge.

It is many years before the oceans disappear. But in time they too are transformed into water vapor, and no more life as we know it is possible in the world. The earth has become a great rocky and sandy ball, whirling through space, lifeless and utterly dry.

That which prevents this from really happening is very simple: In the world as it is, water vapor condenses and changes to drops of water whenever it gets cool enough.

[pg 277]

How water vapor gets into the air. The water vapor gets into the air by evaporation. When we say that water evaporates, we mean that it changes into water vapor. As you already know, it is heat that makes water evaporate; that is why you hang wet clothes in the sun or by the fire to dry: you want to change the water in them to water vapor. The sun does not suck up the water from the ocean, as some people say; but it warms the water and turns part of it to vapor.

What happens down among the molecules when water evaporates is this: The heat makes the molecules dance around faster and faster; then the ones with the swiftest motion near the top shoot off into the air. The molecules that have shot off into the air make up the water vapor.

The water vapor is entirely invisible. No matter how much of it there is, you cannot see it. The weather is just as clear when there is a great deal of water vapor in the air as when there is very little, as long as none of the vapor condenses.

How clouds are formed. But when water vapor condenses, it forms into extremely small drops of real water. Each of these drops is so small that it is usually impossible to see one; they are so tiny that you could lay about 3000 of them side by side in one inch! Yet, small as they are, when there are many of them they become distinctly visible. We see them floating around us sometimes and call them fog or mist. And when there are millions of them floating in the air high above us, we call them a cloud.

[pg 278]

The reason clouds form so high in the air is this: When air or any gas expands, it cools. Do you remember Experiment 31, where you let the gas from a tank expand into a wet test tube and it became so cold that the water on the test tube froze? Well, it is much the same way with rising air. When air rises, there is less air above it to keep it compressed; so it expands and cools. Then

the water vapor in it condenses into droplets of water, and these form a cloud.

Each droplet forms a gathering place for more condensing water vapor, and therefore grows. When the droplets of water in a cloud are very close together, some may be jostled against one another by the wind. And when they touch each other, they stick together, forming a larger drop. When a drop grows large enough it begins to fall through the cloud, gathering up the small droplets as it goes. By the time it gets out of the cloud it has grown to a full-sized raindrop, and falls to earth. The complete story of rain, then, is this:

How rain is caused. The surface of the oceans and lakes is warmed by the sun. The water evaporates, turning to invisible water vapor. This water vapor mingles with the air. After a while the air is caught in a rising current and swept up high, carrying the water vapor with it. As the air rises, there is less air above it to press down on it; so it expands. When air expands it cools, and the water vapor which is mingled with it likewise cools. When the water vapor gets cool enough it condenses, changing to myriads of extremely small drops of water. These make a cloud.

[pg 279]

A wind comes along; that is, the air in which the cloud is floating moves. The wind carries the cloud along with it. More rising air, full of evaporated water from the ocean, joins the cloud and cools, and the water forms into more tiny droplets. The droplets get so close together that they shut out the sun's light from the earth, and people say that the sky is darkening.

Meanwhile some of the droplets begin to touch each other and to stick together. Little by little the drops grow bigger by joining together. Pretty soon they get so big and heavy that they can no longer float high in the air, and they fall to the ground as rain.

Part of the rain soaks into the ground. Some of it gradually seeps down through the ground to an underground stream. This has its outlet in a spring or well, or in an open lake or the ocean. But the rain does not all soak in. After the storm, some of the water again evaporates from the top of the ground and mixes with the warm air, and it goes through the same round. Other raindrops join on the ground to form rivulets that trickle along until they meet and join other rivulets; and all go on together as a brook. The brook joins others until the brooks form a river; and the river flows into a lake or into the ocean.

Then again the sun warms the surface of the ocean or lake; the water evaporates and mixes with the air, which rises, expands, and cools; the droplets form and make clouds; the droplets join, forming big drops, and they fall once more as rain. The rain soaks into the ground or runs off in rivulets, and sooner or later it is once more evaporated. And so the cycle is repeated again and again.

[pg 280]

And all this is accounted for by the simple fact that when water evaporates its vapor mingles with the air; and when this vapor is sufficiently cooled it condenses and forms droplets of water.

The barometer. In predicting the weather a great deal of use is made of an instrument called the *barometer*. The barometer shows how hard the air around it is pressing. If the air is pressing hard, the mercury in the barometer rises. If the air is not pressing hard the mercury sinks. Just before a storm, the air usually does not press so hard on things as at other times; so usually, just before a storm, the mercury in the barometer is lower than in clear weather. You will understand the barometer better after you make one. Here are the directions for making a barometer:

Experiment 87. *To be done by the class with the aid of the teacher.* Use a piece of glass tubing not less than 32 inches long, sealed at one end. Fill this tube to the brim with mercury (quicksilver), by pouring the mercury into it through a paper funnel. Have the sealed end of the tube in a cup, to catch any mercury that spills.⁷ When the tube is full, pour mercury into the cup until there is at least half an inch of it at the bottom. Now put your forefinger very tightly over the open end of the tube, take hold of the sealed end with your other hand, and turn the tube over. Lower the open end, with your finger over it, into the cup. When the mercury in the cup completely covers your finger and the end of the tube, remove your finger carefully so that no air can get up into the tube of mercury. Let the open end of the tube rest gently on the bottom of the cup, and hold the tube upright with your hand or by clamping it to a ring stand. Hold a yardstick or meter stick beside the tube, remembering to keep the tube straight up and down. Measure accurately the height of the mercury column from the *surface* of the mercury in the cup. Then go to the regular barometer hanging on the wall, and read it.

[pg 281]

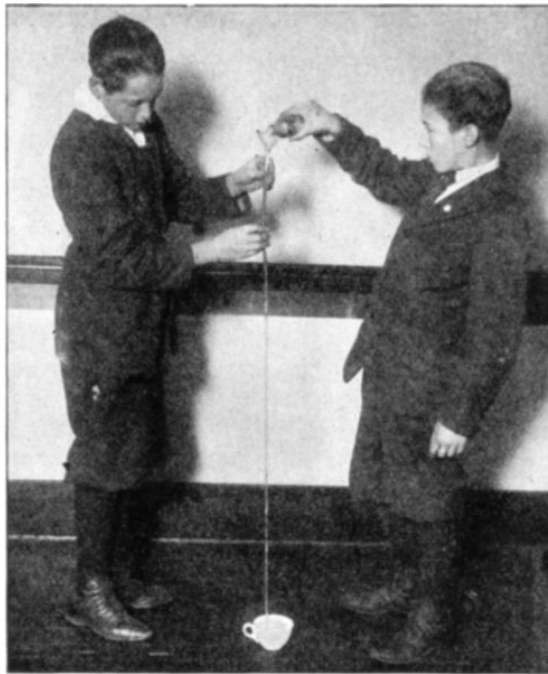

FIG. 152. Filling the barometer tube with mercury.

The reason your barometer may not read exactly the same as the expensive laboratory instrument is that a little air and water vapor stick to the inside of the tube and rise into the "vacuum" above the mercury; also, the tube may not be quite straight up and down. Otherwise the readings would be the same.

Footnote 7: If mercury spills on the floor or table during this experiment, gather it all into a piece of paper by brushing even the tiny droplets together with a soft brush; squeeze it through a towel into a cup to clean it. It is expensive; so try not to lose any of it.

[pg 282]

Of course you understand what holds the mercury up in the tube. If you could put the cup of mercury into a vacuum, the mercury in the tube would sink down into the cup. But the pressure of the air on the surface of the mercury in the cup keeps the mercury from flowing out of the tube and so leaving a vacuum in there. If the air pushes down hard on the mercury in the cup, the mercury will stand high in the tube. This is called *high pressure*. If the air does not press hard on the mercury in the cup, the mercury stands low in the tube. This is called *low pressure*.



[pg 283]

FIG. 153. Inverting the filled tube in the cup of mercury.

How weather is forecast. Weather forecasters make a great deal of use of the barometer, for storms are usually accompanied by low pressure, and clear weather nearly always goes with high pressure.

The reason storms are usually accompanied by low pressure is this: A storm is almost always due to the rising of air, for the rising air expands and cools, and if there is much water vapor in it, this condenses when it cools and forms clouds and rain. Now air rises only when there is comparatively little pressure from above. Therefore, before and during a storm there is not so much pressure on the mercury of the barometer and the barometer is low.

Clear weather, on the other hand, is often the result of air being compressed, for compressing air warms it. When air is being warmed, the water vapor in it will not condense; so the air remains clear. But when the air is being compressed, it presses hard on the mercury of the barometer; the pressure is high, and the mercury in the barometer rises high. Therefore when the mercury in the barometer is rising, the weather is usually clear.

These two statements are true only in a very general way, however. If weather forecasters had only their own barometers to go by, they would not be of much value; for one thing, they could not tell us that a storm was coming much before it reached us. But there are weather stations all over the civilized world, and they

keep in touch with each other by telegraph. It is known that storms travel from west to east in our part of the world. If one weather man reports a storm at his station, and tells how his barometer stands, the weather men to the east of him know that the storm is coming their way. From several such reports the weather men to the east can tell how fast the storm is traveling and exactly which way it is going. Then they can tell when it will reach their station and can make the correct prediction.

Weather men do not have to wait for an actual storm to be reported. If the reports from the west show that the air is rising as it swirls along—that is, if the barometer readings in the west are low—they know that this low-pressure air is approaching them. And they know that low pressure usually means air that is rising and cooling and therefore likely to drop its moisture. In the same way, if the barometers to the west show high pressure, the eastern weather men know that the air that is blowing toward them is being compressed and warmed, and is therefore not at all likely to drop its moisture; so they predict fair weather.



FIG. 154. Finding the pressure of the air by measuring the height of the mercury in the tube.



FIG. 155. The kind of mercury barometer that you buy.

The weather man is not ever certain of his forecasts, however. Sometimes the air will begin to rise just before it gets to him. Then there may be a shower of rain when he has predicted fair weather. Or sometimes the air that has been rising to the west, and which has made him predict bad weather, may stop rising; the storm may be over before it reaches his station. Then his prediction of bad weather is wrong. Or sometimes the storm unexpectedly changes its path. There are many ways in which a weather prophecy may go wrong; and then we blame the weather man. We are likely to remember the times that his prophecy is mistaken and to forget the many, many times when it is right.



FIG. 156. An aneroid barometer is more convenient than one made with mercury. The walls are forced in or spring back out according to the pressure of the air. This movement of the walls forces the hand around.

[pg 286]

How snow is formed. The difference between the ways in which snow and rain are formed is very slight. In both cases water evaporates and its vapor mingles with the warm air. The warm air rises and expands. It cools as it expands, and when it gets cool enough the water vapor begins to condense. *But* if the air as it expands becomes *very* cold, so cold that the droplets of water freeze as they form and gather together to make delicate crystals of ice, snow is formed. The ice crystals found in snow are always six-sided or six-pointed, because, probably, the water or ice molecules pull from six directions and therefore gather each other together along the six lines of this pull. At any rate, the tiny crystals of frozen water are formed and come floating down to the ground; and we call them *snowflakes*. After the snow melts it goes through the same cycle as the rain, most of it finally getting back to the ocean through rivers, and there, in time, being evaporated once more.

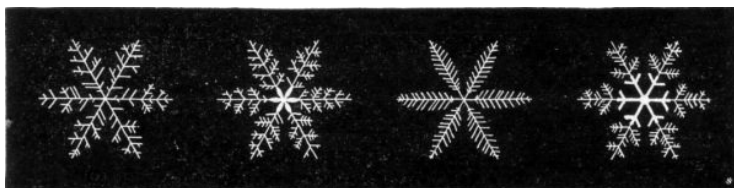

FIG. 157. Different forms of snowflakes. Each snowflake is a collection of small ice crystals.

Hail is rain that happens to be caught in a powerful current of rising air as it forms, and is carried up so high that it freezes in the cold, expanding air into little balls of ice, or hail stones, which fall to the ground before they have time to melt.

[pg 287]

Why one side of a mountain range usually has rainfall. When air that is moving along reaches a mountain range, it either would have to stop, or rise and go over the mountain. The pressure of the air behind it, moving in the same direction, keeps it from stopping, and so it has to go up the slopes and over the range. But as it goes up, there is less air above it to push down on it; so it expands. This makes it cool, and the water vapor in it begins to condense and form snow or rain. Therefore the side of mountain ranges against which the wind usually blows, almost always has plenty of rainfall.

It is different on the farther side of the mountain range. For here the air is sinking. As it sinks it is being compressed. And as it is compressed it is heated. If you hold your finger over the mouth of a bicycle pump and compress the air in the pump by pushing down on the handle, you will find that the pump is decidedly warmed. When the air, sinking down on the farther side of the mountain range, is heated, the water vapor in it is not at all likely to condense. Therefore rain seldom falls on the side of the mountains which is turned away from the prevailing winds.

How dew and frost are formed. The heat of the earth radiates out into the air and on out into space. At night, when the earth loses its heat this way and does not receive heat from the sun, it becomes cooler. When the air, carrying its water vapor, touches the cool leaves and flowers, the water vapor is condensed by the coolness and forms drops of dew upon them. Or, if the night is colder, the droplets freeze as they form, and in the morning we see the grass and shrubs all covered with frost.

[pg 288]

The cause of fogs. When warm air is cooled while it is down around us, the water vapor in it

condenses into myriads of droplets that float in the air and make it foggy. The air may be cooled by blowing in from the warm lake or ocean in the early morning, for at night the land cools more rapidly than the water does. This accounts for the early morning fogs in many cities that are on the coasts.

Likewise when the wind has been blowing over a warm ocean current, the surface of the warm water evaporates and fills the air with water vapor. Then when this air passes over a cold current, the cold current cools the air so much that the moisture in it condenses and forms fog. That is why there are fog banks, dangerous to navigation, in parts of the ocean, particularly off Labrador.

Why you can see your breath on cold days. You really make a little fog when you breathe on a cold morning. The air in your lungs is warm. The moisture in the lungs evaporates into this warm air, and you breathe it out. If the outside air is cold, your breath is cooled; so some of the water vapor in it condenses into very small droplets, and you see your breath.

Here are two experiments in condensing water vapor by cooling the air with which it is mixed. Both work best if the weather is warm or the air damp.

Experiment 88. Put the bell jar on the plate of the air pump and begin to pump the air out of it. Watch the air in the jar. If the day is warm or damp, a slight mist will form.

[pg 289]

As part of the air is pumped out, the rest expands and cools, as warm air does when it rises and is no longer pressed on so hard by the air above it. And as in the case of the rising warm air, the water vapor condenses when it cools, and forms the mist that you see. This mist, like all clouds and fog, consists of thousands of extremely small droplets.

Experiment 89. Hold a saucer of ice just below your mouth. Open your mouth wide and breathe gently over the ice. Can you see your breath?

Now put the ice into half a glass of water and cover the glass. Be sure the outside of the glass is thoroughly dry. Set it aside and look at it again in a few minutes.

What caused the mist when you breathed across the ice?

Where did the water on the outside of the glass of ice water come from? What made it condense?

Application 66. Explain why clouds are formed high in the atmosphere; why we have dew at night instead of in the daytime; why clothes dry more quickly in a breeze than in still air; why clothes dry more quickly on a sunny day than on a foggy one.

Inference Exercise

Explain the following:

411. A gas-filled electric lamp gets hotter than a vacuum lamp.

412. You can remove a stamp from an envelope by soaking it in water.



FIG. 158. If you blow gently over ice, you can see your breath.

[pg 290]



FIG. 159. The glass does not leak; the moisture on it comes from the air.

413. We see our breath on cold days and not on warm days.

414. The electric arc is exceedingly hot.

415. Rock candy is made by hanging a string in a strong syrup left open to the air.

416. Dishes in which candy has been made should be put to soak.

417. Moisture gathers on eyeglasses when the wearer comes from a cold room into a warm one.

418. Sprinkling the street on a hot day makes the air cool.

419. You cannot see things in a dark room.

420. Where air is rising there is likely to be rain.

SECTION 45. *Softening due to oil or water.*

Why does fog deaden a tennis racket?

How does cold cream keep your face from becoming chapped?

Let us now imagine that animal and plant substances have suddenly lost their ability to be softened by oil or water.

[pg 291]

All living things soon feel very uncomfortable. Your face and hands sting and crack; the skin all over your body becomes harsh and dry; your mouth feels parched. The shoes you are wearing feel as if they had been dried over a radiator after being very wet, only they are still harder and more uncomfortable.

A man driving a horse feels the lines stiffening in his hands; and the harness soon becomes so dry and brittle that it cracks and perhaps breaks if the horse stops suddenly.

The leaves on the trees begin to rattle and break into pieces as the wind blows against them. Although they keep their greenness, they act like the driest leaves of autumn.

I doubt whether you or any one can stay alive long enough to notice such effects. For the muscles of your body, including those that make you breathe and make your heart beat, probably become so harsh and stiff that they entirely fail to work, and you drop dead among thousands of other stiff, harsh-skinned animals and people.

So it is well that in the real world oil and water soften practically all plant and animal tissues. Of course, in living plants and animals the oil and water come largely from within themselves. Your skin is kept moist and slightly oily all the time by little glands within it, some of which, called *sweat glands*, secrete perspiration and others of which secrete oil. But sometimes the oil is washed off the surface of your hands, as when you wash an article in gasoline or strong soap. Then you feel that your skin is dry and harsh.

[pg 292]

And when you want to soften it again you rub into it oily substances, like cold cream or vaseline.

In the same way if harness or shoes get wet and then are dried out, they can be made properly flexible by oiling. You could wet them, of course, and this would soften them as long as they stayed wet. But water evaporates rather quickly; so when you want a thing to *stay* soft, you

usually apply some kind of oil or grease.

Just as diffusion and the forming of solutions are increased by heat, this softening by oil and water works better if the oil or water is warm. That is why you soak your hands in *warm* water before manicuring your nails.

Application 67. Explain why women dampen clothes before ironing them; why crackers are put up in waterproof cartons; why an oil shoe polish is better than one containing water.

Inference Exercise

Explain the following:

421. You can shorten your finger nails by filing them.
422. You can do it more quickly after washing them than before.
423. After a flashlight picture is taken, the smoke soon reaches all parts of the room.
424. A jeweler wears a convex lens on his eye when he works with small objects.
425. Shoemakers soak the leather before half-soling shoes.
426. Lightning often sets fire to houses or trees that it strikes.
427. The directions on many bottles of medicine and of preparations for household use say, "Shake well before using."
428. If you set a cold tumbler inside of one that has just been washed in hot water, the outer one will crack in a few minutes.
429. A dry cloth hung out at night becomes wet, while a wet cloth hung out on a clear day dries.
430. Putting cold cream or tallow around the roots of your finger nails will help to prevent hangnails.

[pg 293]

CHAPTER TEN

CHEMICAL CHANGE AND ENERGY

SECTION 46. *What things are made of: Elements.*

What is water made of?

What is iron made of?

Is everything made out of dust?

One of the most natural questions in the world is, "What is this made of?" If we are talking about a piece of bread, the answer is, of course, "flour, water, milk, shortening, sugar, salt, and yeast." But what is each of these made of? Flour is made of wheat, and the wheat is made of materials that the plant gets from the earth, water, and air. Then what are the earth, water, and air made of? A chemist is a person who can answer these questions and who can tell what almost everything is made of. And a strange thing that chemists have found out is this: Everything in the world is made out of one or more of about eighty-five simple substances called *elements*.

What an element is. An element is a substance that is not made of anything else but itself. Gold is one of the eighty-five elements; there are no other substances known to man that you can put together to make gold. It is made of gold and that is all. There is a theory that maybe all the elements are made of electrons in different arrangements, or of electrons and one other thing; but we do not know that, it is only a theory. Carbon is another element; pure charcoal is carbon. The part of the air that we use when we breathe or when we burn things is called *oxygen*. Oxygen is an element; it is not made of anything but itself. There is another gas which is often used to fill balloons that are to go very high; it is the lightest in the world and is called *hydrogen*. Hydrogen is an element.

[pg 294]

For a long time people thought that water was an element. Water certainly looks and seems as if it were made only of itself. Yet during the thousands of years that people believed water was an element, they were daily putting two elements together and making water out of them. When you put a kettle, or anything cold, over a fire, tiny drops of water always form on it. These are not drops of water that were dissolved in the air, and that condense on the sides of the cold kettle; if they were, they would gather on the kettle better in the open air than over the hot fire. Really there is some of that very light gas, hydrogen, in the wood or coal or gas that you use, and this hydrogen joins the oxygen in the air to make water whenever we burn ordinary fuel.

But the best way to prove that water is made of two gases is to take the water apart and get the gases from it. Here are the directions for doing this:

Experiment 90. A regular bought electrolysis apparatus may be used, or you can make a simple one as follows:

Use a tumbler and two test tubes. If the test tubes are rather small (3/8" X 3") they will fill more quickly. Dissolve a little lye (about 1/8 teaspoonful) in half a pint of water to make the water conduct electricity easily, or you may use sulfuric acid in place of lye. Pour half of this solution into the tumbler. Pour as much more as possible into the test tubes, filling both tubes brim full. Cover the mouth of each test tube with a small square of dry paper or cardboard, and turn it upside down, lowering it into the tumbler.

[pg 295]

The "electrodes" are two 3/4" pieces of platinum wire (#30), which are soldered to two pieces of insulated copper wire, each about 2 feet long.⁸ The other ends of the copper wire are bare. Fasten the bare end of one copper wire to one nail of the nail plug if you have direct current (d. c.) in the laboratory, and fasten the bare end of the other wire to the other nail; then turn on the electricity. If you do not have direct current in the laboratory, attach the copper wires to the two poles of a battery instead.

Footnote 8: If the copper wire is drawn through a piece of 1/4-inch soft glass tubing so that only the platinum wire projects from the end of the tube, and the tube is then sealed around the platinum by holding it in a Bunsen burner a few minutes, your electrodes will be more permanent and more satisfactory. The pieces of glass tubing should be about 6 inches long (see Fig. 160).

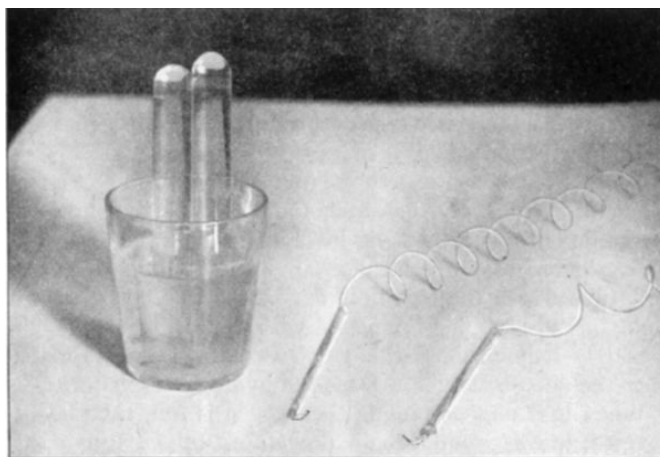

FIG. 160. The electrodes are made of loops of platinum wire sealed in glass tubes.

Bend the platinum electrodes up so that they will stick up into the test tubes from below. Bubbles should immediately begin to gather on the platinum wire and to rise in the test tubes. As the test tubes fill with gas, the water is forced out; so you can tell how much gas has collected at any time by seeing how much water is left in each tube.

[pg 296]

One tube should fill with gas twice as fast as the other. The gas in this tube is hydrogen; there is twice as much hydrogen as there is oxygen in water. The tube that fills more slowly contains oxygen.

When the faster-filling tube is full of hydrogen—that is, when all of the water has been forced out of it—take the electrode out and let it hang loose in the glass. Put a piece of cardboard about 1 inch square over the mouth of the test tube; take the test tube out of the water and turn it right side up, keeping it covered with the cardboard. Light a match, remove the cardboard cover, and hold the match over the open test tube. Does the hydrogen in it burn?

When the tube containing the oxygen is full, take it out, covered, just as you did the hydrogen test tube. But in this case make the end of a stick of charcoal glow, remove the cardboard from the tube, and then plunge the glowing charcoal into the test tube full of oxygen.

Only oxygen will make charcoal burst into flame like this.

When people found that they could take water apart in this way and turn it into hydrogen and oxygen, and when they found that whenever they combined hydrogen with oxygen they got water, they knew, of course, that water was not an element. Maybe some day they will find that some of the eighty-five or so substances that we now consider elements can really be divided into two or more elements; but so far the elements we know show no signs of being made of anything except themselves.

The last section of this book will explain something about the way the chemist goes to work to find out what elements are hidden in compounds.

[pg 297]

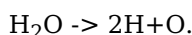

FIG. 161. Water can be separated into two gases by a current of electricity.

The quick way chemists write about elements. Since everything in the world is made of a combination or a mixture of elements, chemists have found it very convenient to make abbreviations for the names of the elements so that they can quickly write what a thing is made of. They indicate hydrogen by the letter H. O always means oxygen to the chemist; C means carbon; and Cl means chlorine, the poison gas so much used in the World War. The abbreviation stands for the Latin name of the element instead of for the English name, but they are often almost alike. The Latin name for the metal sodium, however, is *natrum*, and chemists always write Na when they mean sodium; this is fortunate, because S already stands for the element sulfur. Fe means iron (Latin, *ferrum*). But I stands for the element iodine. (The iodine you use when you get scratched is the element iodine dissolved in alcohol.) It is not necessary for you to remember the chemical symbols unless you mean to become a chemist or unless you read a good deal about chemistry. But almost every one knows at least that H means hydrogen, O means oxygen, and C means carbon.

[pg 298]

When a chemist wants to show that water is made of hydrogen two parts and oxygen one part, he writes it very quickly like this: H_2O (pronounced "H two O"). " H_2O " means to a chemist just as much as "w-a-t-e-r" means to you; and it means even more, because it tells that water is made of two parts hydrogen and one part oxygen. If a chemist wanted to write, "You can take water apart and it will give you two parts of hydrogen and also one part of oxygen," this is what he would put down:



If he wanted to show that you could combine two parts of hydrogen and one part of oxygen to form water, he would write it quickly like this:

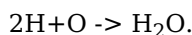

These are called *chemical equations*. You do not need to remember them; they are put here merely so that you will know what they look like. Some of them are much longer and more complicated, like this:

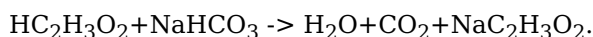

This is the chemist's way of saying, "Vinegar is made of one part of hydrogen gas that will come off easily and that gives it its sour taste, two parts of carbon, three parts of hydrogen that does not come off so easily, and two parts of oxygen. When you put this with baking soda, which is made of one part of the metal sodium, one part of hydrogen, one part of carbon, and three parts of oxygen, you get water and carbon dioxide gas and a kind of salt called sodium acetate." Or, more briefly, "If you put baking soda with vinegar, you get water, a gas called carbon dioxide, and a salt." You can see how much shorter the chemist's way of writing it is.

[pg 299]

Some elements you already know. Here is a list of some elements that you are already pretty well acquainted with. The abbreviation is put after the name for each. This list is only for reference and need not be learned.

Aluminum (Al)

Carbon (C) Charcoal, diamonds, graphite (the lead in a pencil is graphite), hard coal, and soot are all made of carbon.

Chlorine	(Cl)	A poison gas that was used in the war.
Copper	(Cu)	
Gold	(Au)	
Hydrogen	(H)	The lightest gas in the world; you got it from water in the last experiment and will get it from an acid in the next.
Iodine	(I)	It is a solid; what you use is iodine dissolved in alcohol.
Iron	(Fe)	
Lead	(Pb)	
Mercury	(Hg)	This is another name for quicksilver.
Nickel	(Ni)	
Nitrogen	(N)	About four fifths of the air is pure nitrogen.
Oxygen	(O)	This is the part of the air we use in breathing. You got some out of water, and you will have it to deal with in another experiment.
Phosphorus	(P)	Phosphorus makes matches glow in the dark, and it makes them strike easily.
Platinum	(Pt)	
Radium	(Ra)	
Silver	(Ag)	
Sodium	(Na)	You are not acquainted with sodium by itself, but when it is combined with the poison gas, chlorine, it makes ordinary table salt.
Sulfur	(S)	
Tin	(Sn)	
Zinc	(Zn)	

[pg 300]

For the rest of the elements you can refer to any textbook on chemistry.

How elements hide in compounds. One strange thing about an element is that it can hide so completely, by combining with another element, that you would never know it was present unless you took the combination apart. Take the black element carbon, for instance. Sugar is made entirely of carbon and water. You can tell this by making sugar very hot. When it is hot enough, it turns black; the water part is driven off and the carbon is left behind. Yet to look at dry, white sugar, or to taste its sweetness, one would never suspect that it was made of pure black, tasteless carbon and colorless, tasteless water. Mixing carbon and water would never give you sugar. But combining them in the right proportions into a chemical compound does produce sugar.

Not only is carbon concealed in sugar, but it is present in all plant and animal matter. That is why burning almost any kind of food makes it black. You drive off most of the other elements and separate the food into its parts by getting it too hot; the water evaporates and so does the nitrogen; what is left is mainly black carbon.

[pg 301]

Making hydrogen come out of hiding. The light gas, hydrogen, conceals itself as perfectly as carbon does by combining with other elements. It is hiding in everything that is sour and in many things that are not sour. And you can get it out of sour things with metals. In some cases it is harder to separate than in others; and some metals separate it better than others do. But one sour compound that you can easily get the hydrogen out of is hydrochloric acid (HCl), which is hydrogen combined with the poison gas, chlorine. One of the best metals to get the hydrogen out with is zinc. Here are the directions for doing it and incidentally for making a toy balloon:

Experiment 91. *Do this experiment on the side of the laboratory farthest from any flames or fire. Do not let any flame come near the flask in which you are making hydrogen.*

In the bottom of a flask put two or three wads of zinc shavings, each about the size of your thumb. Fit a one-hole rubber stopper to the flask. Take the stopper out and put a piece of glass tubing about 5 inches long through the hole of the stopper, letting half an inch or so stick down into the flask when the stopper is in place (Fig. 162). With a rubber band fasten the mouth of a rubber balloon over the end of the glass tube that will be uppermost. Fill the balloon by blowing through the glass tube to see if all connections are tight, and to see how far it may be expanded without danger of breaking. You can tell when the balloon has about all it will hold, by pressing gently with your fingers. If the rubber feels tight, do not blow any more. Let the air out of the balloon again.

[pg 302]

Now get some hydrochloric acid (HCl) diluted with three parts of water. Find the bottle marked "HCl, dilute 1-3," in which the acid is already diluted. Before you open the bottle, get some solution of soda, and keep it near you; if in this experiment or any other you spatter acid on your hands or face or clothes, wash it off *immediately* with soda solution. *Remember this.* Ammonia will do as well as the soda solution to wash off the acid, but be careful not to get it into your eyes.



FIG. 162. Filling a balloon with hydrogen.

Pour the hydrochloric acid (HCl) on the zinc shavings in the bottom of the flask, until the acid stands about an inch deep. Then quickly put the rubber stopper with its attachments into the flask, so that the gas that bubbles up will blow up the balloon.

[pg 303]



FIG. 163. Adding more acid without losing the gas.

If the bubbles do not form rapidly, ask the teacher to pour a little strong hydrochloric acid into the flask; but this will probably not be necessary. Let the balloon keep filling until it is as large as you blew it. But if the bubbles stop coming before it gets as large as that, close the neck of the balloon by pinching it tightly, and take the stopper out. Let some one add more zinc shavings and more acid to the flask; put the stopper back in, and stop pinching the neck of the balloon. *In this and all other experiments when you use strong acids, pour the used acids into the crockery jar that is provided for such wastes. Do not pour them into the sink, as acids ruin sink drainpipes.*

[pg 304]

When the balloon is full, close the neck by slipping the rubber band up from the part of the neck that is over the glass tube on to the upper part of the neck. Pull the balloon off the glass tube and pinch the neck firmly shut. Take the stopper out and rinse the flask several times with running water. Any zinc that is left should be rinsed thoroughly, dried, and set aside so that it may be used again. Now tie one end of a long thread firmly around the mouth of the balloon and let the balloon go. Does it rise? If it does not, the reason is that you did not get it full enough. In that case make more hydrogen and fill it fuller, as explained above.

Here is another experiment with hydrogen:

Experiment 92. Put a wad of zinc shavings, about the size of the end of your little

finger, into the bottom of a test tube. Cover it with hydrochloric acid (HCl) diluted one to three, as in the preceding experiment. After the bubbles have been rising for a couple of minutes, take the test tube to the side of the laboratory where the burners are, and hold a lighted match at its mouth. Will hydrogen burn?

Remember that the hydrogen which the zinc is driving out of the acid is exactly the same as the hydrogen you drove out of water with an electric current. There is a metal called *sodium* (Na) and another called *potassium* (K) which are as soft as stiff putty and as shiny as silver; if you put a tiny piece of sodium (Na) or potassium (K) on water, it will drive the hydrogen out of the water just as zinc drove it out of the acid. The action is so swift and violent and releases so much heat that the hydrogen which is set free catches fire. This makes it look as if the metal were burning as it sputters around on top of the water. There is so much sputtering that the experiment is dangerous; people have been blinded by the hot alkaline water spattering into their eyes. So you cannot try this until sometime when you take a regular course in chemistry.

[pg 305]

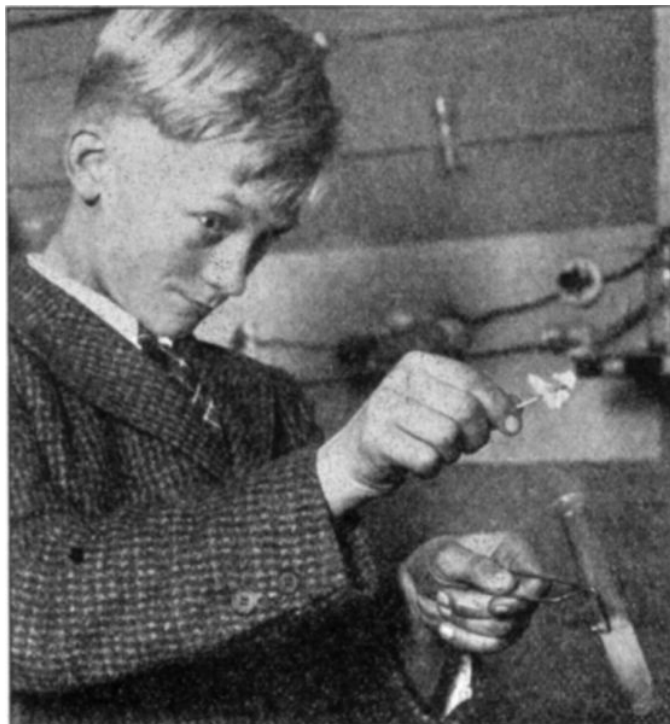

FIG. 164. Trying to see if hydrogen will burn.

Getting oxygen, a gas, from two solids. Oxygen (O) can hide just as successfully as hydrogen. Practically all elements can do the same by combining with others. Here is an experiment in which you can get the gas, oxygen, out of a couple of solids. If you went to the moon or some other place where there is no air, you could carry oxygen very conveniently locked up in these solid substances. Oxygen, you remember, is the part of the air that keeps us alive when we breathe it.

Experiment 93. In a test tube mix about one half teaspoonful each of white potassium chlorate crystals and black grains of manganese dioxid. Put a piece of glass tubing through a cork so that the tubing will stick down a little way into the test tube. *Do not put the glass tubing through the cork while the cork is in the test tube: insert the glass tubing first, then put the cork into the test tube.* Put one end of a 2-foot piece of rubber tubing over the glass tube and put the other end into a pan of water.

[pg 306]



FIG. 165. Filling a bottle with oxygen.

Fill a flask or bottle to the brim with water, letting it overflow a little; hold a piece of cardboard firmly over the mouth of the bottle; turn the bottle upside down quickly, putting the mouth of it under water in the pan; take the cardboard away. The water should all stay in the bottle.

Now shove the rubber tube into the neck of the bottle until it sticks up an inch or two. During this experiment, be careful not to let the neck of the bottle or flask pinch the rubber tubing; small pieces of wood or glass tubing laid beside the rubber tubing where it goes under the run of the neck will prevent this.

Hold, the test tube, tightly corked, over the flame of a burner, keeping the tube at a slant and moving it slightly back and forth so that all the material in it will be thoroughly heated. If you stop heating the test tube even for a couple of seconds, take the cork out; if you do not remove the cork, the cooling gas in the test tube will shrink and allow the water from the pan to be forced through the rubber tube into the test tube, breaking it into pieces.

[pg 307]



FIG. 166. The iron really burns in the jar of oxygen.

When enough gas has bubbled up into the bottle to force all the water out, and when bubbles begin to come up outside the bottle, uncork the test tube and lay it aside where it will not burn anything; then slide the cardboard under the mouth of the bottle and turn it right side up; leave the cardboard on the bottle.

Light a piece of charcoal, or let a splinter of wood burn a few minutes and then blow it out so that a glowing coal will be left on the end of it. Lift the cardboard off the bottle and plunge the glowing stick into it for a couple of seconds. Cover the bottle after taking out the stick, and repeat, using a lighted match or a burning piece of wood instead of the glowing stick. If you dip a piece of iron picture wire in sulfur and light it, and then plunge it into the bottle, you will see iron burn.

[pg 308]

Both manganese dioxid and potassium chlorate have a great deal of oxygen bound up in them. When they join together, as they do when you heat them, they cannot hold so much oxygen, and it escapes as a gas. In the experiment, the escaping oxygen passed through the tube, filled the bottle, and forced the water out.

What burning is. When anything burns, it is simply joining oxygen. When a thing burns in air, it cannot join the oxygen of the air very fast, for every quart of oxygen in the air is diluted with a gallon of a gas called *nitrogen*. Nitrogen will not burn and it will not help anything else to burn. But when you have pure oxygen, as in the bottle, the particles of wood or charcoal or picture wire can join it easily; so there is a very bright blaze.

Although free oxygen helps things to burn so brilliantly, a match applied to the solids from which you got it would go out. And while hydrogen burns very easily, you cannot burn water although it is two-thirds hydrogen. Water is H_2O , you remember.

What compounds are. When elements are combined with other elements, the new substances that are formed are called *compounds*. Water (H_2O) is a compound, because it is made of hydrogen and oxygen combined.

[pg 309]

When elements unite to form compounds, they lose their original qualities. The oxygen in water will not let things burn in it; the hydrogen in water will not burn. Salt ($NaCl$) is a compound. It is made of the soft metal sodium (Na), which when placed on water sputters and drives hydrogen out of the water, and the poison gas chlorine (Cl), combined with each other. And salt is neither dangerous to put in water like sodium, nor is it a greenish poison gas like chlorine.

Mixtures. But sometimes elements can be mixed without their combining to form compounds, in such a way that they keep most of their original properties. Air is a mixture. It is made of oxygen (O) and nitrogen (N). If they were *combined*, instead of *mixed*, they might form laughing gas,—the gas dentists use in putting people to sleep when they pull teeth. So it is well for us that air is only a *mixture* of oxygen and nitrogen, and *not* a compound.

You found that things burned brilliantly in oxygen. Well, things burn in air too, because a fifth of the air is oxygen and the oxygen of the air has all its original properties left. Things do not burn as brightly in air as they do in pure oxygen for the same reason that a teaspoonful of sugar mixed with 4 teaspoonfuls of boiled rice does not taste as sweet as pure sugar. The sugar itself is as sweet, but it is not as concentrated. Likewise the oxygen in the air is as able to help things burn as pure oxygen is; but it is diluted with four times its own volume of nitrogen.

[pg 310]

A solution is a mixture, too; for although substances disappear when they dissolve, they keep their own properties. Sugar is sweet whether it is dissolved or not. Salt dissolved in water makes brine; but the water will act in the way that it did before. It will still help to make iron rust; and salt will be salty, whether or not it is dissolved in water. That is why solutions are only mixtures and are not chemical compounds.

Everything in the world is made of atoms. Everything in the world is either an element or a compound or a mixture. Most plant and animal matter is made of very complicated compounds, or mixtures of compounds. All pure metals are elements; but metals, when they are melted, can be dissolved in each other to form alloys, which really are mixtures. Most of the so-called gold and silver and nickel articles are really made of alloys; that is, the gold, silver, or nickel has some other elements dissolved in it to make it harder, or to impart some other quality. Bronze and brass are always alloys; steel is generally an alloy made chiefly of iron but with other elements such as tungsten, of which electric lamp filaments are made, dissolved in it to make it harder. An alloy is a special kind of solution not quite like an ordinary solution.

You remember that in the opening chapters we often spoke of molecules, the tiny particles of matter that are always moving rapidly back and forth. Well, if you were to examine a molecule of water with the microscope which we imagined could show us molecules, you would find that the molecule of water was made of three still smaller particles, called *atoms*. Two of these would be atoms of hydrogen and would probably be especially small; the third would be larger and would be an oxygen atom.

[pg 311]

In the same way if you looked at a *molecule* of salt under this imaginary microscope, you would probably find it made of *two atoms*, one of sodium (Na) and one of chlorine (Cl), held fast together in some way which we do not entirely understand.

The smallest particle of an *element* is called an *atom*.

The smallest particle of a *compound* is called a *molecule*.

Molecules are usually made of two or more atoms joined together.

Application 68. In the following list tell which things are elements, which are compounds, and which are mixtures, remembering that both solutions and alloys are mixtures:

Air, water, salt, gold, hydrogen, milk, oxygen, radium, nitrogen, sulfur, baking soda, sodium, diamonds, sweetened coffee, phosphorus, hydrochloric acid, brass.

Inference Exercise

Explain the following:

431. Although in most electric lamps there is a vacuum between the glowing filaments and the glass, the glass nevertheless becomes warm.
432. Clothes left out on the line overnight usually become damp.
433. You can separate water into hydrogen and oxygen, yet you cannot separate the hydrogen or the oxygen into any other substances.
434. Wet paper tears easily.
435. Windows are soiled on the outside much more quickly in rainy weather than in clear weather.
436. If you stir iron and sand together, the iron will rust as if alone.
437. Rust is made of iron and oxygen, yet you cannot separate the iron from the oxygen with a magnet.
438. A reading glass helps you to read fine print.
439. Stretching the string of a musical instrument more tightly makes the note higher.
440. Mayonnaise dressing, although it contains much oil, can readily be washed off a plate with cold water.

[pg 312]

SECTION 47. *Burning: Oxidation.*

What makes smoke?

What makes fire burn?

Why does air keep us alive?

Why does an apple turn brown after you peel it?

If oxygen should suddenly lose its power of combining with other things to form compounds, every fire in the world would go out at once. You could go on breathing at first, but your breathing would be useless. You would shiver, begin to struggle, and death would come, all within a minute or two. Plants and trees would die, but they would remain standing until blown down by the wind. Even the fish in the water would all die in a few minutes,—more quickly than they usually do when we take them out of the water. In a very short time everything in the world would be dead.

Then suppose that this condition lasted for hundreds and hundreds of years, the oxygen remaining unable to combine with other elements. During all that time nothing would decay. The trees would stay as they fell. The corpses of people would dry and shrivel, but they would lie where they dropped as perfectly preserved as the best of mummies. The dead fish would float about in the oceans and lakes.

This is all because life is kept up by burning. And burning is simply the combining of different things with oxygen. If oxygen ceased to combine with the wood or gas or whatever fuel you use, that fuel could not burn; how could it when "burning" *means* combining with oxygen? The heat in your body and the energy with which you move come entirely from the burning (oxidation) of materials in your body; and that is why you have to breathe; you need to get more and more oxygen into your body all the time to combine with the carbon and hydrogen in the cells of which your body is made. Plants breathe, too. They do not need so much oxygen, since they do not keep warm and do not move around; but each plant cell needs oxygen to live; there is burning (oxidation) going on in every living cell. Fishes breathe oxygen through their gills, absorbing the oxygen that is dissolved in the water. They do not take the water apart to get some of the combined oxygen from it; there is always some free oxygen dissolved in any water that is open to the air. It is clear that fires would all go out and everything would die if burning (combining with oxygen) stopped.

[pg 313]

The reason things would not decay is that decay usually is a slow kind of oxidation (burning). When it is not this, it is the action of bacteria. But bacteria themselves could not live if they had *no* oxygen; so they could not make things decay.

Not only would the dead plants and animals remain in good condition, but the clothes people were wearing when they dropped dead would stay unfaded and bright colored through all the storms and sunshine. And the iron poles and car tracks and window bars would remain unruined. For bleaching and rusting are slow kinds of oxidation or burning (combining with oxygen).

Here are two experiments which show that you cannot make things burn unless you have oxygen to combine with them:

[pg 314]

Experiment 94. Light a candle not more than 4 inches long and stand it on the plate of the air pump. Cover it with the bell jar and pump the air out. What happens to the flame?

Experiment 95. Fasten a piece of candle 3 or 4 inches long to the bottom of a pan. Pour water into the pan until it is about an inch deep. Light the candle. Turn an empty milk bottle upside down over the candle. Watch the flame. Leave the bottle over the candle until the bottle cools. Watch the water around the bottom of the bottle. Lift the bottle partly out of the water, keeping the mouth under water.

The bubbles that came out for a few seconds at the beginning of the experiment were caused by the air in the bottle being heated and expanded by the flame. Soon, however, the oxygen in the air was used so fast that it made up for this expansion, and the bubbles stopped going out. When practically all the oxygen was used, the flame went out.

The candle is made mostly of a combination of hydrogen and carbon. The hydrogen combines with part of the oxygen in the air that is in the bottle to form a little water. The carbon combines with the rest of the oxygen to make carbon dioxide, much of which dissolves in the water below. So there is practically empty space in the bottle where the oxygen was, and the air outside forces the water up into this space. The rest of the bottle is filled with the nitrogen that was in the air and that has remained unchanged.

About how much of the air was oxygen is indicated by the space that the water filled after the oxygen was combined with the candle.

[pg 315]



FIG. 167. The water rises in the bottle after the burning candle uses up the oxygen.

Carbon and hydrogen the chief elements in fuel. Carbon and hydrogen make up the larger part of almost every substance that is used for fuel, including gas, gasoline, wood, and soft coal; alcohol, crude oil, kerosene, paper, peat, and the acetylene used in automobile and bicycle lamps. Hard coal, coke, and charcoal are, however, chiefly plain carbon. Since burning is simply the combining of things with oxygen, it is plain that when the carbon of fuel joins oxygen we shall get carbon dioxide (CO_2). When the hydrogen in the fuel joins oxygen, what must we get?

[pg 316]

When things do not burn up completely, the carbon may be left behind as charcoal. That is what happens when food "burns" on the stove. But if anything burns up entirely, the carbon or charcoal burns too, passing off as the invisible gas, carbon dioxide, just as the hydrogen burns to form steam or water.

It is because almost every fuel forms water when it burns, that we find drops of water gathering on the outside of a cold kettle or cold flatiron if either is put directly over a flame. The hydrogen in the fuel combines with the oxygen of the air to form steam. As the steam strikes the cold kettle or iron, it condenses and forms drops of water.

Nothing ever destroyed. One important result of the discovery that burning is only a combining of oxygen with the fuel was that people began to see that nothing is ever destroyed. There is exactly as much carbon in the carbon dioxide that floats off from a fire as there was in the wood that was burned up; and there is exactly as much hydrogen in the water vapor that floats off from the fire as there was in the wood. Chemists have caught all the carbon dioxide and the water vapor and weighed them and added their weight to the weight of the ashes; and they have found them to weigh even more than the original piece of wood, because of the presence of the oxygen

that combined with them in the burning.

[pg 317]

If everything in the world were to burn up, using the oxygen that is already here, the world would not weigh one ounce more or less than it does now. All the elements that were here before would still be here; but they would be combined in different compounds. Instead of wood and coal and oxygen we should have water and carbon dioxide; instead of diamonds, we should have just carbon dioxide; and so on with everything that can burn.

Why water puts out a fire. Water puts out a fire because it will not let enough free oxygen get to the wood, or whatever is burning, to combine with it. The oxygen that is locked up in a compound, like water, you remember, has lost its ability to combine with other things. Sand puts out a fire in the same way that water does. Most fire extinguishers make a foam of carbon dioxide (CO₂) which covers the burning material and keeps the free oxygen in the air from coming near enough to combine with it.

Water will not put out burning oil, however, as the oil floats up on top of the water and still combines with the oxygen in the air.

Why electric lamps are usually vacuums. Electric lamps usually have vacuums inside because the filament gets so hot that it would burn up if there were any oxygen to combine with it. But in a globe containing no oxygen the filament may be made ever so hot and it cannot possibly burn.

[pg 318]

High-power electric lamps are not made with vacuums but are "gas-filled." The gas that is oftenest put into lamps is nitrogen,—the same gas that is mixed with the oxygen in air. By taking all the oxygen out of a quantity of air, the lamp manufacturers can use in perfect safety the nitrogen that is left. It will not combine with the glowing filament. There is no oxygen to combine with the filament; so the lamp does not burn out.

What flames are. When you look at a flame, it seems as if fire were a real thing and not merely a process of combining something with oxygen. The flame is a real thing. It is made up of hot gases, rising from the hot fuel, and it is usually filled with tiny glowing particles of carbon. When you burn a piece of wood, the heat partly separates its elements, just as heating sugar separates the carbon from the water. Some of the hydrogen gas in the wood and some of the carbon too are separated from the wood by the heat. These are pushed up by the cooler air around and combine with the oxygen as they rise. The hydrogen combines more easily than the carbon; part of the carbon may remain behind as charcoal if your wood does not all burn up, and many of the smaller carbon particles only glow in the burning hydrogen, instead of burning. That is what makes the flame yellow. If you hold anything white over a yellow flame, it will soon be covered with black soot, which is carbon.

What smoke is. Smoke consists mostly of little specks of unburned carbon. That is why it is gray or black. When you have black smoke, you may always be sure that some of the carbon particles are not combining properly with oxygen.

[pg 319]

Yellow flames are usually smoky; that is, they usually are full of unburned bits of carbon that float off above the flame. But by letting enough air in with the flame, it is possible to make all the little pieces of carbon burn (combine with the oxygen of the air) before they leave the heat of the burning hydrogen. That is why kerosene lamps do not smoke when the chimney is on. The chimney keeps all the hot gases together, and this causes a draft of fresh air to blow up the chimney to push the hot gases on up. The fresh air blowing up past the flame gives plenty of oxygen to combine with the carbon. The drum part of an oil heater acts in the same way; when the drum is open, the heater smokes badly; when it is closed up, enough air goes past the flame to burn up all the carbon. But if you turn either lamp or heater too high, it will smoke anyway; you cannot get enough air through to combine with all the carbon.

The hottest flames are the blue flames. That is because in a blue flame all the carbon is burning up along with the hydrogen of the fuel—both are combining with the oxygen of the air as rapidly as possible. A gas or gasoline stove is so arranged that air is fed into the burner with the gas. You will see this in the following experiment:

Experiment 96. Light the Bunsen burner in the laboratory. Open wide the little valve in the bottom. Now put your finger and thumb over the hole in the bottom of the burner. What happens to the flame? Turn the valve so that it will close the hole in the same way. Now hold a white saucer over the flame, being careful not to get it hot enough to break. What is the black stuff on the bottom of the saucer?

[pg 320]

Examine the gas plate (small gas stove) in the laboratory. Light it, and see if you can find the place where the air is fed in with the gas. Close this place and see what happens. Open it wider and see what happens. If the air opening is too large, the flame "blows"; there is too much cold air coming in with the gas, and your flame is not as hot as it would be if it did not "blow." Also, the stove is liable to "back-fire" (catch fire at the air opening) when the air opening is too wide.

Application 69. An oil lamp tipped over and the burning oil spread over the floor. Near by were a pail of water, a pan of ashes, a rug, and a seltzer siphon. Which of these might have been used to advantage in putting out the fire?



FIG. 168. The Bunsen burner smokes when the air holes are closed.

Application 70. My finger was burned. I wanted the flesh around it to heal and new skin cells to live and grow rapidly around the burn.

"Put a rubber finger cot on the finger and keep all air out," one friend advised me. "Air causes decay and will therefore be bad for the burn."

"He's wrong; you should bandage it with clean cloth; you want air to reach the finger, I've heard," said another friend.

"Oh, no, you don't; air makes things burn, and the burn will therefore get worse," still another one said. What should I have done?

Application 71. Two students were discussing how coal was formed.

"The trees must have fallen into water and been completely covered by it, or they would have decayed," said one.

[pg 321]



FIG. 169. Regulating the air opening in a gas stove.

"Water makes things decay more quickly; there must have been a drought and the trees must have fallen on dry ground," said the second.

Which was right?

Application 72. A gas stove had a yellow flame. In front, by the handles, was a metal disk with holes so arranged that turning it to the left allowed air to mix with the gas on the way to the flame, and turning it to the right shut the air off (see Fig. 170).

One member of the family said, "Turn the disk to the left and let more air mix with the gas."

But another objected. "It has too much air already; that's why the flame is yellow. Turn it to the right and shut off the air from below."

"You're both wrong. Why do you want to change it?" said a third member of the family. "The yellow flame is the hottest, anyway. Can't you see that the yellow flame gives more light? And don't you know that light is just a kind of radiant heat? Of course the yellow flame is the hottest. Leave the stove alone."

Who was right?

[pg 322]

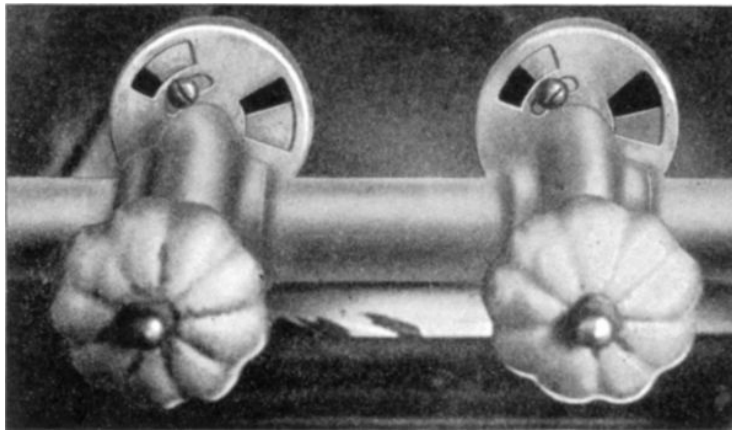

FIG. 170. The air openings in the front of a gas stove.

Inference Exercise

Explain the following:

441. Iron tracks are welded together with an electric arc.
442. The cool mirror in a bathroom becomes covered with moisture when you take a hot bath.
443. This prevents you from seeing yourself in the mirror.
444. Carbon dioxide has oxygen in it, yet a burning match dropped into a bottle of it will go out.
445. A ship that sinks to the bottom of the ocean does not decay.
446. When women put their hair in curlers, they usually moisten the hair slightly.
447. To dry a pan after washing it, a person often sets it on the hot stove for a few minutes.
448. When you put a kettle of cold water over a gas flame, drops of water appear on the lower part of the sides of the kettle.
449. Electric power plants are often situated where running water will turn the dynamo. Explain the necessity of turning the dynamo.
450. We make carbon dioxide by burning carbon, but you cannot put different things together to make carbon.

[pg 323]

SECTION 48. *Chemical change caused by heat.*

Why do you have to strike a match to make it burn?

How does pulling the trigger make a gun go off?

What makes cooked foods taste different from raw ones?

Has it struck you as strange that we do not all burn up, since burning is a combining with oxygen, and we are walking around in oxygen all the time? The only reason we do not burn up is that it usually requires heat to start a chemical change. You already know this in a practical way. You know that you have to rub the head of a match and get it hot before it will begin to burn; that gunpowder does not go off unless you heat it by the sudden blow of the gun hammer which you release when you pull the trigger; that you have to concentrate the sun's rays with a magnifying glass to make it set a piece of paper on fire; and that to change raw food into food that tastes pleasant you have to heat it. If heat did not start chemical change, you could never cook food,—partly because the fire would not burn, and partly because the food would not change its taste even if heated by electricity or concentrated sunlight.

Here is an experiment to show that gas will not burn unless it gets hot enough:

Experiment 97. Hold a wire screen 2 or 3 inches above the mouth of a Bunsen burner. Turn on the gas and light a match, holding the lighted match *above* the screen. Why, do you suppose, does the gas below the screen not burn? Hold a lighted match to the gas below the screen. Does it burn now?

The reason the screen kept the gas below it from catching fire although the gas above it was

[pg 324]

burning was this: The heat from the flame above was conducted out to the sides by the wire screen as soon as it reached the screen; so very little heat could get through the screen to the gas below. Therefore the gas below the screen never got hot enough for the chemical change of oxidation, or burning, to take place. So the gas below it did not catch fire.

Another simple experiment with the Bunsen burner, that shows the same thing in a different way, is this:

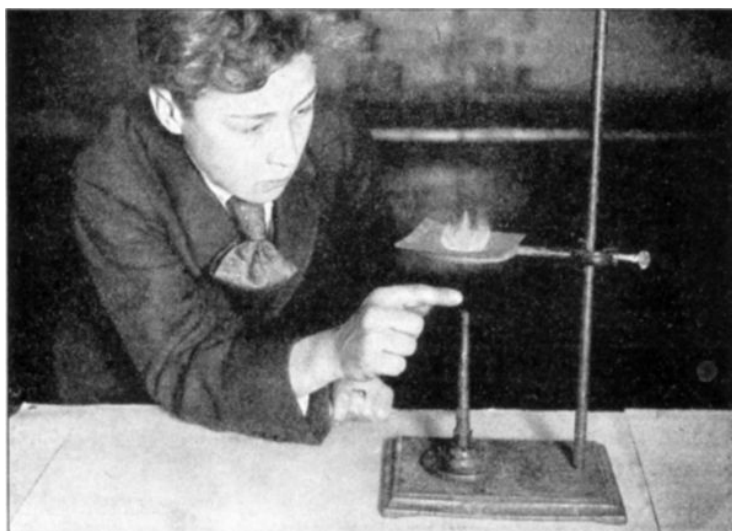

FIG. 171. Why doesn't the flame above the wire gauze set fire to the gas below?

Experiment 98. Light the Bunsen burner. Open the air valve at the bottom all the way. Hold the wood end of a match (not the head) in the center of the inner greenish cone of flame, about half an inch above the mouth of the burner. Does the part of the match in the center of the flame catch fire? Does the part on the edge? What do you suppose is the reason for this? Where are the cold gas and air rushing in? Can they get hot all at once, or will they have to travel out or up a way before they have time to get hot enough to combine?

[pg 325]



Fig. 172. The part of the match in the middle of the flame does not burn.

Application 73. Explain why boiled milk has a different taste from fresh milk; why blowing on a match will put it out; why food gets black if it is left on the stove too long.

Inference Exercise

Explain the following:

451. When you want bread dough to rise, you put it in a warm place.

452. Ink left long in an open inkwell becomes thick.

453. A ball bounces up when you throw it down.

454. When the warm ocean air blows over the cool land in the early morning, there is a heavy fog.

[pg 326]

455. Striking a match makes it burn.

456. When you have something hard to cut, you put it in the part of the scissors nearest the handles.

457. A magnet held over iron filings makes them leap up.

458. Dishes in which flour thickening or dough has been mixed should be washed out with cold water.

459. A woolen sweater is liable to stretch out of shape after being washed.

460. When a telegraph operator presses a key in his set, a piece of iron is pulled down in the set of another operator.

SECTION 49. *Chemical change caused by light.*

How can a camera take a picture?

Why does cloth fade in the sun?

What makes freckles?

If light could not help chemical change, nothing would ever fade when hung in the sun; wall paper and curtains would be as bright colored after 20 years as on the day they were put up, if they were kept clean; you would never become freckled, tanned, or sunburned; all photographers and moving-picture operators would have to go out of business; but worst of all, every green plant would immediately stop growing and would soon die. Therefore, all cows and horses and other plant-eating animals would die; and then the flesh-eating animals would have nothing to eat and they would die; and then all people would die.

You will be able better to understand why all this would happen after you do the following experiments, the first of which will show that light helps the chemical change called bleaching or fading.

Experiment 99. Rinse two small pieces of light-colored cloth. (Lavender is a good color for this experiment.) Lay one piece in the bright sun to dry; dry the other in a dark cabinet or closet. The next day compare the two cloths. Which has kept its color the better? If the difference is not marked, repeat the experiment for 2 or 3 days in succession, putting the same cloth, wet, in the sun each time.

[pg 327]

Bleaching is usually a very slow kind of burning. It is the dye that is oxidized (burned), not the cloth. Most dyes will combine with the oxygen in the air *if they are exposed to the sunlight*. The dampness quickens the action.

Why some people freckle in the sun. When the sunlight falls for a long time on the skin, it often causes the cells in the under part of the skin to produce some dark coloring matter, or pigment. This dark pigment shows through the outer layer of skin, and we call the little spots of it *freckles*. Some people are born with these pigment spots; but when the freckles come out from long exposure to the sunlight, they are an example right in our own skins of chemical change caused by the action of light. Tan also is due to pigment in the skin and is caused by light.

The next experiments with their explanations will show you how cameras can take pictures. If you are not interested in knowing how photographs are made, do the experiments and skip the explanations down to the middle of page [332](#).

Experiment 100. Dissolve a small crystal of silver nitrate (AgNO_3) in about half an inch of pure water in the bottom of a test tube. Distilled water is best for this purpose. Now add one drop of hydrochloric acid (HCl). The white powder formed is a silver salt, called *silver chlorid* (AgCl); the rest of the liquid is now a diluted nitric acid (HNO_3).

[pg 328]

Pour the suspension of silver chlorid (AgCl) on a piece of blotting paper or on a paper towel, so that the water will be absorbed. Spread the remaining white paste of silver chlorid (AgCl) out over the blotter as well as you can. Cover part of it with a key (or anything that will shut off the light), and leave the other part exposed. If the sun is shining, put the blotter in the sunlight for 5 minutes. Otherwise, let as much daylight fall on it as possible for about 10 minutes. Now take the key off the part of the silver chlorid (AgCl) that it was covering and compare this with the part that was exposed to

the light. What has the light done to the silver chlorid (AgCl) that it shone on?

What has happened is that the light has made the silver (Ag) *separate* from the chlorine (Cl) of the silver chlorid (AgCl). Chemists would write this:

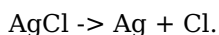

That is, silver chlorid (AgCl) has changed into silver (Ag) and chlorine (Cl). Chlorine, as you know, is a poisonous gas, and it floats off in the air, leaving the fine particles of silver behind. When silver is divided into very tiny particles, it absorbs light instead of reflecting it; so it looks dark gray or black.

How photographs are made. All photography depends on this action of light. The plates or films are coated with a silver salt,—usually a more sensitive salt than silver chlorid. This is exposed to the light that shines through the lens of the camera. As you have learned, the lens brings the light from the object to a focus and makes an image on the film or plate. The light parts of this image will change the silver salt to silver; the dark parts will not change it. So wherever there is a white place on the object you are photographing, there will be a dark patch of silver on the film or plate, and wherever there is a dark spot on the object, there will be no change on the film or plate.

[pg 329]

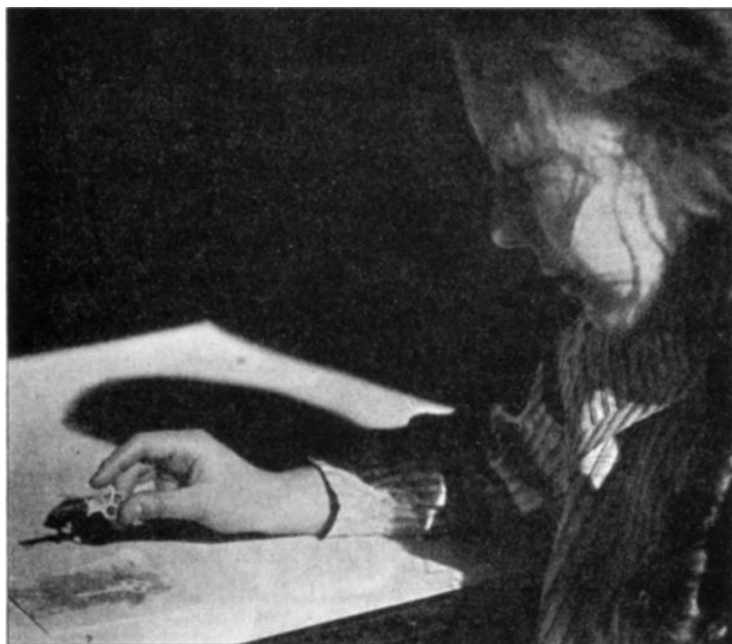

FIG. 173. The silver salt on the paper remains white where it was shaded by the key.

As a matter of fact, the film or plate is exposed such a short time that there is not time for the change to be completed. So the photographer develops the negative; he washes it in some chemicals that finish the process which the light started.

If he exposed the whole plate to the light now, however, all the *unchanged* parts of the silver salt would also be changed by the light, and there would be no picture left. So before he lets any light shine on it, except red light which has no effect on the silver salt, he dissolves off all the white unchanged part of the silver salt, in another kind of chemical called the *fixing bath*. This is called "fixing" the negative.

[pg 330]

The only trouble with the picture now is that wherever there should be a patch of white, there is a patch of dark silver particles; and wherever there should be a dark place, there is just the clear glass or celluloid, with all the silver salt dissolved off. This kind of picture is called a *negative*; everything is just the opposite shade from what it should be. A white man dressed in a black suit looks like a negro dressed in a white suit.

How a photographic print is made. The negative not only has the lights and shadows reversed, but it is on celluloid or glass, and except for moving pictures and stereopticons, we usually want the picture on paper. So a print is made of the negative. The next experiment will show you how this is done.

Experiment 101. In a dark room or closet, take a sheet of blueprint paper from the package, afterwards closing the package carefully so that no light can get to the papers inside. Hold the piece of blueprint paper under your waist or coat, to keep it dark when you go into the light. Now lay it, greenish side downward, on a negative. Hold the two together, or place them in a printing frame, and turn them over so that the light will shine through the negative upon the greenish side of the blueprint paper. Be sure that the paper is held firmly against the negative and not moved around. Let the sun shine

through the negative upon the paper for 1 or 2 minutes according to the brightness of the sun, or let the gray light of the sky, if it is cloudy, shine on it for 5 or 10 minutes. Now quickly put the blueprint paper (not the negative) into a basin of water, face down. Wash for a couple of minutes. Turn it over and examine it. If it has been exposed to the light too long, it will be dark; if it has been exposed too short a time, it will be too light; in either case, if the print is not clear, repeat with a fresh piece of blueprint paper, altering the time of exposure to the sunlight to improve the print.

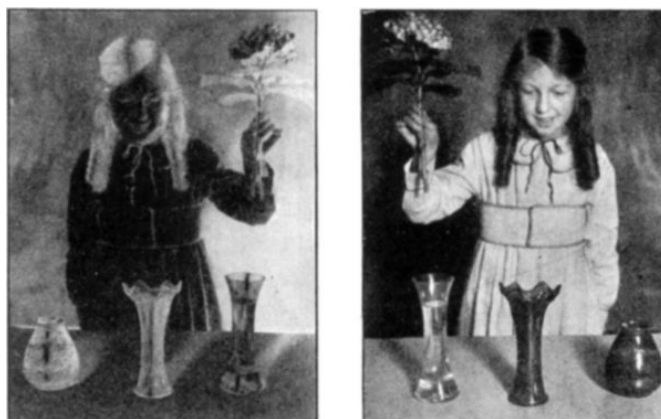

FIGS. 174 and 175. Where the negative is dark, the print is light.

You can make pretty outline pictures of leaves and pressed flowers, or of lace, by laying these on the blueprint paper in place of the negative and in other respects doing as directed above.

In making blueprints you are changing an iron salt instead of a silver salt, by the action of light. Regular photographic prints are usually made on paper treated with a silver salt rather than with iron salt, and sometimes a gold or platinum salt is used. But these other salts have to be washed off with chemicals since they do not come off in water, as the unchanged part of the iron salt comes off when you fix the blueprint paper in the water bath.

Since the light cannot get through the black part of a negative, the coating on the paper behind that part is not affected and it stays light colored; and since the light can get through the clear parts of the negative, the coating on the paper back of those parts *is* affected and becomes dark. Therefore, the print is "right side out,"—there is a light place on the print for every white place on the object photographed, and there is a dark place on the print for every black place on the object.

Moving-picture films are printed from one film to another, just as you printed from a negative to a piece of paper. The negative is taken on one film, then this is printed on another film. The second film is "right side out."

Light and the manufacture of food in plants. Much the most important chemical effect of light, however, is not in making photographs, in bleaching things, or in "burning" your skin. It is in the putting together of carbon and water to make sugar in plants. Plants get water (H_2O) from the earth and carbon dioxide (CO_2) from the air. When the sun shines on chlorophyll, the green substance in plants, the chlorophyll puts them together and makes sugar. The plant changes this sugar into starch and other foods, and into the tissues of the plant itself. Nothing in the world can put carbon dioxide and water together and make food out of them except certain bacteria and the chlorophyll of plants. And light is absolutely necessary for this chemical action. Try this experiment:

Experiment 102. Pin together two pieces of cork on opposite sides of a leaf that is exposed to the sun. The next day take this leaf from the plant and heat it in a beaker of alcohol until the green coloring matter is removed from the leaf. Then place the leaf in a glass of water that contains iodine. The iodine will color the leaf dark where the cells contain starch. (See Experiment 115, page 373.) Is starch formed where the light does not reach the leaf?

No plant can make food except with the help of light. The part of the plant that can put carbon dioxide and water together is the green stuff or chlorophyll, and this can work only when light is shining on it. So all plants would die without light.

But if all plants should die, all animals would die also, for animals cannot make food out of carbon dioxide and water, as they do not have the chlorophyll that puts these things together. A lion does not live on leaves, it is true, but he lives on deer and other animals that do live on leaves and plants. If the plants died, all plant-eating animals would die. Then there would be nothing for the flesh-eating animals to eat except each other, and in time no animals would be left in the world. The same thing would happen to the fish. And man, of course, could no longer exist. The food

supply of the world depends on the fact that light can start chemical change.

[pg 334]

Oxygen released in the manufacture of plant food. Besides in one way or another giving us all of our food, plants, helped by light, also give us most of the free oxygen that we breathe. We and all animals get the energy by which we live by *combining* oxygen with the hydrogen of our food (forming water) and by combining oxygen with the carbon in our food (forming carbon dioxide). This combining (burning or oxidizing) gives us our body heat and the energy to move. The free oxygen is carried to the different parts of our bodies by the red blood corpuscles that float in the liquid part of the blood. The liquid part of the blood also carries the food to the different parts of the body, and the food contains the carbon and hydrogen that is to be burned. Then in a muscle, for instance, the oxygen that has been carried by the corpuscles combines with the carbon to form carbon dioxide, and with the hydrogen to form water. The corpuscles carry part of the carbon dioxide back to the lungs, and the water is carried with other wastes and the rest of the carbon dioxide in the liquid part of the blood. In the lungs the carbon dioxide is exchanged for the free oxygen we have just inhaled, and we exhale the carbon dioxide. A good deal of water is also breathed out, as you can tell from the way the mist gathers on a window pane when you blow on it.

If there were only animals (including people) in the world, all the free oxygen in the air would in time be combined by the animals with hydrogen to make water and with carbon to make carbon dioxide (CO₂). As animals cannot breathe water and cannot get any good from carbon dioxide, they would all smother.

[pg 335]

But the plants, as we have already said, use carbon dioxide (CO₂) and water (H₂O) to make food. They do not need so much oxygen, and so they set some of it free. The countless plants in the world set the oxygen free as rapidly as the countless animals combine it with hydrogen to make water and with carbon to make carbon dioxide. Since the water and carbon dioxide are the main things a plant needs to make its food, the animals really are as helpful to the plants as the plants are to the animals. For the animals furnish the materials to the plants for making their food in exchange for the ready-made food furnished by the plant. And both plants and animals would die if light stopped helping to bring about chemical change.

Application 74. Explain why the heart of a cabbage is white instead of green like the outside leaves; why a photographer works in a dark room with only a ruby light; why you get freckled in the sun.

Inference Exercise

Explain the following:

461. If a pin is put through a lamp cord, a fuse is likely to blow out.
462. The wall paper back of a picture is often darker than that on the rest of the wall.
463. If you wet an eraser, it rubs through the paper.
464. Clothes are hot after being ironed.
465. If you drop candle grease on your clothes, you can remove the grease by placing a blotter over it and pressing the blotter with a warm iron.
466. Milliners cover hats that are on display in windows where the sun shines in on the hats.
467. You pull down on a rope when you try to climb it.
468. In taking a picture, you expose the sensitive film or plate to the light for a short time.
469. Good cameras have an adjustable front part so that the lens may be moved nearer to the plate or film, or farther from it, according to the distance of the object to be photographed.
470. A pencil has to be resharpened frequently when it is much used.

SECTION 50. *Chemical change caused by electricity.*

How are storage batteries charged?

How is silver plating done by electricity?

[pg 336]

You have already done an experiment showing that electricity can start chemical change, for you changed water into hydrogen and oxygen by passing a current of electricity through the water.

The plating of metals is made possible by the fact that electricity helps chemical change. You can nickel plate a piece of copper in the following manner:

Experiment 103. Dissolve a few green crystals of "double nickel salts" in water, until the water is a clear green. The water should be about 2 or 3 inches deep in a glass or china bowl that is not less than 5 inches across.

Lay two bare copper wires across the bowl, about 3 inches apart, as shown in Figure 177. Connect the positive wire from a storage battery, or the wire from the carbon of a battery of three or four cells, to an end of one bare wire. Connect the negative wire from the storage or the negative wire from the zinc of the other battery to an end of the second bare wire.

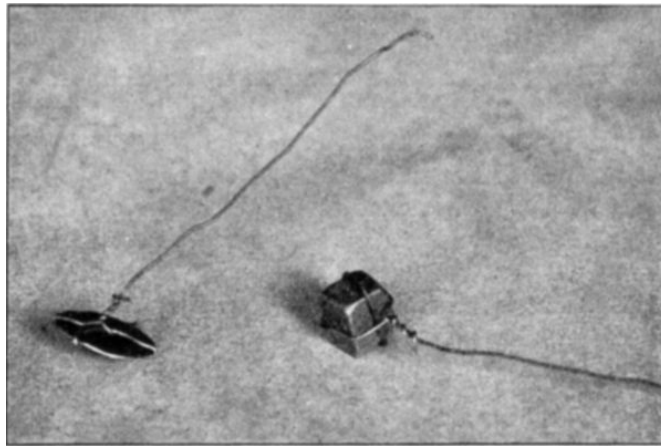

FIG. 176. The copper and the nickel cube ready to hang in the cleansing solution.

Now fasten a fine bare wire 5 or 6 inches long around a small piece of copper, and another like it around a piece of nickel, as shown in Figure 176. Then put the piece of copper in the bottom of an evaporating dish, with the wire hanging out, as in Figure 177.



FIG. 177. Cleaning the copper in acids.

Pour over the piece of copper enough of the cleansing solution to cover it.⁹ *The cleansing solution contains strong acids. If you get any on your skin or clothes, wash it off immediately with ammonia or soda.* As soon as the copper is bright and clean, take it out of the cleansing solution and suspend it by the *negative* wire in the green nickel solution. You can tell if you have it on the negative wire, for in that case bubbles will rise from it during the experiment. The copper should be entirely covered by the nickel solution, but should not touch the bottom or sides of the bowl. Pour the cleansing solution from the evaporating dish back into the bottle. Suspend the nickel, in the same way as the copper, from the *positive* wire crossing the bowl. When set up, the apparatus should appear as shown in Figure 178.

Footnote 9:

The formula for making the cleansing solution is as follows:

1 cup water.

1 cup concentrated sulfuric acid.

1 cup concentrated nitric acid.

1 teaspoonful concentrated hydrochloric acid.

The sulfuric and nitric acids must be measured in glass or china cups, and the hydrochloric acid must be measured in a silver-plated spoon or in glass—not in tin.



FIG. 178. Plating the copper by electricity.

Turn on the electricity. If the copper becomes black instead of silvery, clean it again in the cleansing solution, and move the two bare wires much farther apart,—practically the full width of the bowl. If the copper still turns black, it means that too much electricity is flowing. In that case use fewer batteries.

[pg 339]

The electricity has started two chemical changes. It has made part of the piece of nickel combine with part of the solution of nickel salt to form more nickel salt, and it has made some of the nickel salt around the copper change into metallic nickel. Then the negative electricity in the copper has attracted the positive bits of nickel metal made from the nickel salt, and made them cling to the copper. If there is no dirt or grease on the copper, the particles of nickel get so close to it that they stick by adhesion, even after the electric attraction has ceased. This leaves the copper nickel-plated, but to make it shiny the nickel plating must be polished.

Silver plating and gold plating are done substantially in the way that you have done the nickel plating, only gold salt or silver salt is used instead of nickel salt.

Just as electricity helps chemical changes in plating, it helps changes in a storage battery. But in the storage battery the new compounds formed by "charging" the battery change back again and generate electricity when the poles of the battery are connected with each other by a good conductor.

Application 75. Explain how spoons can be silver plated; how water can be changed into hydrogen and oxygen.

Inference Exercise

Explain the following:

471. Clothes dry best in the sun and wind.

472. Proofs of photographs that have not been thoroughly "fixed" fade if left out of their envelope.

473. Blowing a match puts it out, yet a good draft is necessary for a hot fire.

474. A cup does not naturally fall apart, yet after it is broken it falls apart even if you fit the pieces together again.

475. Crayon leaves marks on a blackboard.

476. A baked potato tastes very different from a raw one.

[pg 340]

477. An air-filled automobile tire is harder at noon than in the early morning.

478. When a live trolley wire breaks and falls to the street, it becomes so hot that it burns.

479. Glass jars of fruit should be kept in a fairly dark place.

480. You wash dishes in *hot* water.

SECTION 51. *Chemical change releases energy.*

Why is fire hot?

What makes glowworms glow?

Why does cold quicklime boil when you pour cold water on it?

If no energy were released by chemical change, we should run down like clocks, and could never be wound up again. We could breathe, but to do so would do us no more good than it would if oxygen could not combine with things. Oxidation would go on in our bodies, but it would neither keep us warm nor help us to move. A few spasmodic jerks of our hearts, a few gasps with our lungs, and they would stop, as the muscles would have no energy to keep them going.

The sunlight *might* continue to warm the earth, as we are not sure that the sun gets any of its heat from chemical change. But fires, while they would burn for an instant, would be absolutely cold; no energy would be given out by the fuel combining with oxygen. But the fires could not burn long, because there would be nothing to keep the gases and fuel hot enough to make them combine with the oxygen.

[pg 341]

Even during the instant that a fire lasted it would be invisible, for it would give off no light if no energy were released by the chemical change. Only electric lights and heaters would continue to work, and even some of these would fail. The electric motors in submarines and electric automobiles would instantly stop; battery flashlights would go out as quickly as the fire; no doorbells would ring. In short, all forms of electric batteries would stop sending currents of electricity out through their wires, and everything depending upon batteries would stop running.

A fire gives out heat and light; both are kinds of energy. And it is the electric energy caused by the chemical change in batteries that runs submarines, electric automobiles, flashlights, and doorbells. Since burning (oxidation) is simply a form of chemical change, it is not difficult to realize that chemical change releases energy.

Why glowworms glow. When a glowworm glows at night, or when the head of a match glows as you rub it on your wet hand in the dark, we call the light *phosphorescence*. The name "phosphorus" means light-bearing, and anything like the element phosphorus, that glows without actively burning, is said to be phosphorescent. Match heads have phosphorus in them. Phosphorescence is almost always caused by chemical change. The energy released is a dim light, not heat or electricity. Sometimes millions of microscopic sea animals make the sea water in warm regions phosphorescent. They, like fireflies, glowworms, and will-o'-the-wisps, have in them some substance that is slowly changing chemically, and energy is released in the form of dim light as the change takes place. Most luminous paint is phosphorescent for the same reason, —there is a chemical change going on that releases energy in the form of light.

[pg 342]

When you poured the hydrochloric acid on the zinc to make hydrogen, the flask became warm; the chemical change going on in the flask released heat energy.

Application 76. Explain why pouring cold water on cold quicklime makes the slaked lime that results boiling hot; why a cat's eyes shine in the dark; why a piece of carbon and a piece of zinc placed in a solution of sal ammoniac will make electricity run through the wire that connects them; why fire is hot.

Inference Exercise

Explain the following:

481. A baking potato sometimes bursts in the oven.

482. Turpentine is used in mixing paint.

483. Sodium is a metal; chlorine is a poisonous gas; yet salt, which is made up of these two, is a harmless food.

484. When bricklayers mix water with cement and lime, the resulting mortar boils and steams.

485. Green plants will not grow in the dark.

486. Parts of the body are constantly uniting with oxygen. This keeps the body warm.

487. Water will not always put out a kerosene fire.

488. Delicately colored fabrics should be hung in the shade to dry.

489. A match glows when you rub it in the dark.

490. Candy hardens when it cools.

SECTION 52. *Explosions.*

What makes a gun shoot?

What makes an automobile go?

Usually we think of explosions as harmful, and they often are, of course. Yet without them we could no longer run automobiles; gasoline launches would stop at once; motorcycles would no longer run; gasoline engines for pumping water or running machinery would not be of any use; and all aviation would immediately cease. Tunneling through mountains, building roads in rocky places, taking up tree stumps, and preparing hard ground for crops would all be made very much more difficult. War would have to be carried on much as it was during the Middle Ages; soldiers would use spears and bows and arrows; battleships would be almost useless in attacking; modern forts would be of little value; cannon, guns, rifles, howitzers, mortars, and revolvers would all be so much junk.

[pg 343]

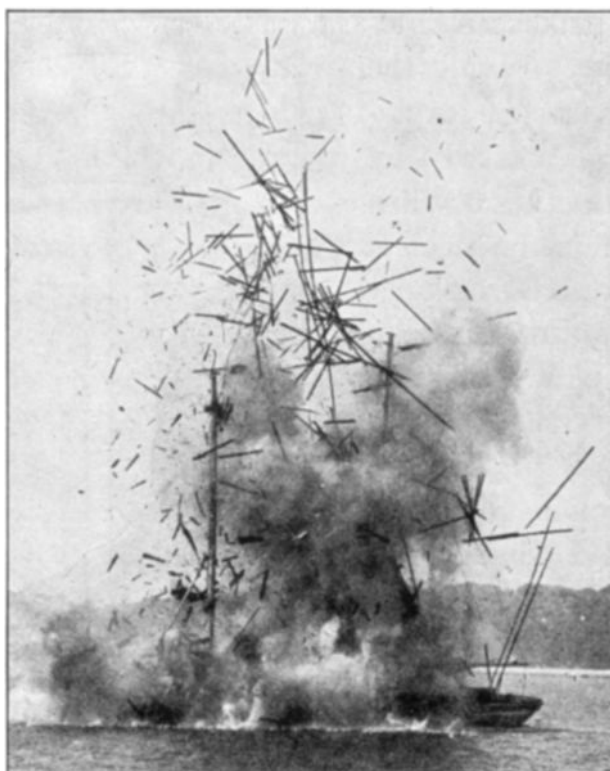

FIG. 179. The explosion of 75 pounds of dynamite. A "still" from a motion-picture film.

What makes an automobile go. In all the above cases the explosions are caused by chemical action. When gasoline mixed with air is sprayed into the cylinder of an automobile, an electric spark makes the gasoline combine with the oxygen of the air; the gasoline suddenly burns and changes to steam and carbon dioxide. As you already know, when a liquid like gasoline turns to gases such as steam and carbon dioxide, the gases take much more room. But that is not all that happens. Much heat is released by the burning of the gasoline spray, and heat causes expansion. So the gases formed by the burning gasoline are still further expanded by the heat released by the burning. Therefore they need a great deal more room; but they are shut up in a small place in the top of a cylinder. The only thing to hold them up in this small space, however, is a piston (Fig. 180), and the suddenly expanding gases shove this piston down and escape. The piston is attached to the drive wheel of the automobile, and when the piston is pushed down it gives the automobile a push forward. If it were not for the expansion of a gas in the cylinder, this gas being confined to a small space, the piston would not be pushed down.

[pg 344]

[pg 345]

An explosion is simply the sudden pushing of a confined gas expanding on its way to freedom. The gasoline vapor and air were the confined gas. Their chemical combining made them expand; by pushing the piston out of its way the newly formed gas suddenly freed itself. This was an explosion, and it gave the automobile one forward push. But the automobile engine is so arranged that the piston goes up into the cylinder again, and is pulled down again, drawing a spray of gasoline and air into the cylinder after it. Then it goes up a second time, an electric spark explodes the gasoline, the piston is forced down violently once more, and so it goes on.

There are several cylinders, of course, and the explosions take place within them one after the other so as to keep the automobile going steadily.

How a gun shoots. Pulling a trigger makes a gun shoot by causing an explosion. There is a spring on the hammer of a gun. This drives the hammer down suddenly when you release the spring by pulling the trigger. The hammer jars the chemicals in the cap and causes them to explode. The heat and flame then cause the oxygen in the gunpowder to combine with some of the other elements in the powder to make a gas. The gas requires more room than the powder and is further expanded by the heat released by the chemical change. The expanding gas frees itself by pushing the bullet out of its way. The bullet gets such a push through the exploding of the gunpowder that it may fly to a mark and pierce it.

[pg 346]

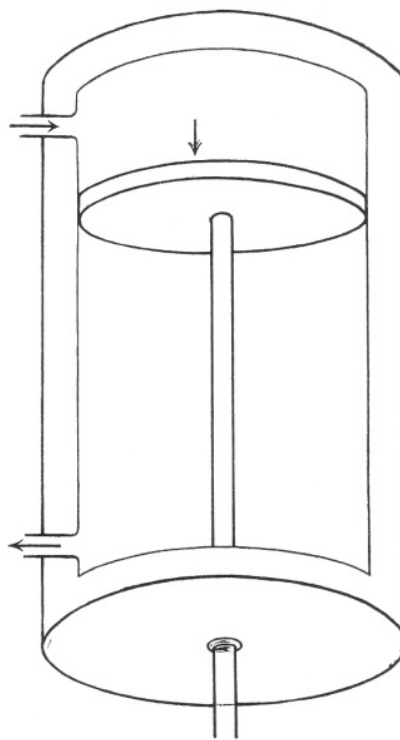

FIG. 180. Diagram of the cylinder of an engine. The piston is driven forward by the explosion of the gasoline in the cylinder.



FIG. 181. The most powerful explosions on earth occur in connection with volcanic activity. The photograph shows Mt. Lassen, California, the only active volcano in the United States.

There is a slight explosion even when you shoot an air gun. First you compress some air in the upper part of the barrel of the air gun; then you suddenly release it. The only thing in the way of the expanding air is the bullet; so the air pushes this out in front of it.

[pg 347]

In Experiment 36, where you stoppered a test tube containing a little water and then held the tube over a flame until the cork flew out, you were causing an explosion. As the water changed to steam, the steam was an expanding gas. It was at first confined to the test tube by the cork. Then there was an explosion; the gas freed itself by blowing out the cork.

Steam boilers have safety valves to prevent explosions. These are valves so arranged that when the steam expands and presses hard enough to endanger the boiler, the steam will open the valves and escape instead of bursting the boiler to get free.

Explosives. Dynamite, gunpowder, and most explosives are mixtures of solids or liquids that will combine easily and will form gases that expand greatly as a result of the combination. One of the essentials in explosives is some compound of oxygen (such as the manganese dioxid or potassium chlorate you used to make oxygen in Experiment 93) which will easily set its oxygen free. This oxygen combines very swiftly with something else in the explosive, releasing heat and forming a gas that takes much more room. In its effort to free itself, this expanding gas will blast rocks out of the way, shoot cannon balls, or do any similar work.

But if gunpowder does not have to push anything of much importance out of its way to expand,

there is no explosion. That is why a firecracker merely fizzes when you break it in two and light the powder. The cardboard no longer confines the expanding gas; so there is nothing to burst or to push violently out of the way.

[pg 348]

Useful explosions are generally caused by a chemical action which suddenly releases a great deal of heat and combines solid things into expanding gases. But the bursting of a steam boiler, or the "blow out" of an automobile tire, or the bursting of a potato in the oven, although not caused by chemical action, still are real explosions. An explosion is the *sudden* release of a confined gas.

Application 77. Explain how gasoline makes a motorcycle go, and why it goes "pop, pop, pop." Explain why a paper bag will burst with a bang, when you blow it up and then clap it between your hands; why a Fourth-of-July torpedo "goes off" when you throw it on the pavement.

Inference Exercise

Explain the following:

491. The engine of an automobile is cooled by the water that passes over it from the radiator.

492. When you light a firecracker, the flame travels down the wick until it reaches the gunpowder, and then the firecracker bursts with a bang.

493. If you light a small pile of gunpowder in the open, as you do when you make a squib by breaking the firecracker in two, you merely have a blaze.

494. Air-filled tires make bicycles ride much more evenly than solid tires would.

495. When clay has once been baked into brick, you can never change it back to clay.

496. A photographic negative turns black all over if it is exposed to the light before it is "fixed."

497. The outside of a window shade fades.

498. A vacuum electric lamp globe feels hot instantly when turned on, but if turned off again at once, it immediately feels cold.

499. Coal gas is made by heating coal very hot in an air-tight chamber.

500. White straw turns yellow when it is long exposed to the sunlight.

[pg 349]

CHAPTER ELEVEN

SOLUTION AND CHEMICAL ACTION

SECTION 53. *Chemical change helped by solution.*

Why does iron have to get wet to rust?

Is it good to drink water with your meals?

When iron rusts, it is really slowly burning (combining with oxygen). If your house is on fire, you throw water on it to stop the burning. Yet if you throw water on iron it rusts, or burns, better than if you leave it dry. What do you suppose is the reason for this?

The answer is not difficult. You know perfectly well that iron does not burn easily; we could not make fire grates and stoves out of iron if it did. But when iron is wet, a little of it dissolves in the water that wets it. There is also a little oxygen dissolved in the water, as we know from the fact that fish can breathe under the water. This *dissolved* oxygen can easily combine with the *dissolved* iron; the *solution* helps the chemical change to take place. The chemical change that results is oxidation,—the iron combining with oxygen,—which is a slow kind of burning; and in iron this is usually called *rusting*.¹⁰ But when we pour water on burning wood, the wood *stops* burning, for there is not nearly enough oxygen dissolved in water to combine rapidly with burning wood; and the water shuts off the outside air from burning wood and therefore puts the fire out.

Footnote 10: The rusting of iron is not quite as simple as this, as it probably undergoes two or three changes before finally combining with oxygen. But the solution helps all these changes.

Another chemical change, greatly helped by solution, is the combining of the two things that baking powder is made of, and the setting free of the carbon dioxide (CO₂) that is in one of them.

Try this experiment:

[pg 350]

Experiment 104. Put half a teaspoonful of baking powder in the bottom of a cup and add a little water. What happens?

The chemical action which takes place in the baking powder and releases the gas in bubbles—the gas is carbon dioxide (CO₂)—will not take place while the baking powder is dry; but when it is dissolved, the chemical change takes place in the solution.

If you ate your food entirely dry, you would have a hard time digesting it; and this would be for the same reason that baking powder will not work without water. Perhaps you can drink too much water with a meal and dilute the digestive juices too much; certainly you should not use water to wash down your food and take the place of the saliva, for the saliva is important in the digestion of starch. But you need also partly to dissolve the food to have it digest well. Crackers and milk are usually more easily digested than are plain crackers, for the milk partly dissolves the crackers, and drinking one or two glasses of water with a meal hastens the digestion of the food.

Application 78. Explain why paint preserves wood; why iron will rust more quickly in a wet place than it will either under water or in a dry place; why silver salts must be dissolved in order to plate a spoon by electricity.

Inference Exercise

Explain the following:

501. There is dew on the grass early in the morning.
502. Cold cream makes your hands and face soft.
503. Glowworms and fireflies can be seen on the darkest nights.
504. A lake looks gray on a cloudy day and blue on a clear day.
505. Dried fruit will keep much longer than fresh fruit.
506. If you scratch a varnished surface, you can rub the scratch out completely by using a cloth wet with alcohol.
507. Soda is usually dissolved in a little water before it is added to a sour-milk batter.
508. Iron rusts when it gets wet.
509. Peroxide is usually kept in brown bottles.
510. Dry lye may be kept in tin cans, but if the lye is *moistened* it will eat the can.

SECTION 54. *Acids.*

Why are lemons sour?

How do acids act?

Some acids are very powerful. There is one, called *hydrofluoric acid*, that will eat through glass and has to be kept in wax bottles; and all acids tend to eat or corrode metals. You saw what hydrochloric acid did to the zinc shavings when you wanted to make a balloon; or, to be more accurate, you saw what the zinc shavings did to the acid, for the hydrogen gas that bubbled off was driven out of the acid by the zinc. Then the zinc combined with the rest of the acid to form what chemists call a *salt*.

If we were to let the soft metal, sodium, act on hydrochloric acid, we should get hydrogen also; but the salt that formed would be regular table salt (NaCl). You cannot do this experiment, however, as the sodium does its work so violently that it is dangerous.

Experiment 105. *To be done by the teacher before the class. If acid spatters on any one's skin or clothes, wash it off immediately with ammonia or a strong soda solution.*



FIG. 182. Etching copper with acid.

Drop a little candle grease on a piece of copper about $\frac{3}{4}$ inch wide and 2 or 3 inches long. In the flame of a Bunsen burner, gently heat the end of the copper that has the candle grease (paraffin) on it, so that the paraffin will spread out all over the end. Let it harden. With a nail, draw a design in the paraffin on the copper, scratching through the thin coat of paraffin to the copper below. Pour a couple of drops of concentrated nitric acid on the paraffin-covered end of the piece of copper, and spread the acid with a match so that it can get down into the scratches. Let it stand by an open window for 5 or 10 minutes. Do not inhale the brown fumes that are given off. They are harmless in small amounts, but if breathed directly they are very irritating. Now wash off the acid by holding the copper under the hydrant, and scrape off the paraffin.

[pg 353]

The nitric acid did to the copper in this experiment exactly what the hydrochloric acid did to the zinc shavings when you made the toy balloon. The copper drove the hydrogen out of the nitric acid and incidentally broke down some of the nitric acid to make the brown gas, and then the copper joined the rest of the nitric acid to make a salt called *copper nitrate*. This salt is green, and it dissolves in water. When you washed the copper, the green salt was washed away and a dent remained in the copper where the copper salt had been.

Here is a more practical experiment showing the action of acid on metal:

Experiment 106. Use two knives, one of bright steel and the other a silver-plated one. If the steel knife is not bright, scour it until it is. Drop a little lemon juice on each knife and let it stand for a few minutes, while the teacher does the next experiment. Then rinse both knives and examine them. What has the lemon juice done to the silver knife? to the steel one?

The lemon juice acts in this way because it is acid. Acids act on the taste nerves in the tongue and give the taste of sourness; everything sour is an acid. The black stuff formed on the steel knife by the lemon juice is an iron salt. The iron in the knife drove the hydrogen out of the lemon juice, but there was not enough for you to see it coming off; then the iron combined with the rest of the lemon juice to form an iron salt.

Whenever an acid acts on a metal, the metal drives off the hydrogen and forms a salt. The salt is not always good to eat; for instance, the salt that tin forms with acids is poisonous.

[pg 354]

Action of acids on other substances. Acids do not act on metals only, however. Watch the next experiment to see what a strong acid will do to cloth.

Experiment 107. *To be done by the teacher.* Put a drop of concentrated nitric or sulfuric acid on a piece of colored wool cloth, or on a piece of colored silk. Let it stand for a few minutes, then rinse it thoroughly. Test the cloth where the acid has been to see whether or not it is as strong as the rest of the cloth. How has the acid affected the color?



FIG. 183. Strong acids will eat holes like this in cloth.

[pg 355]

Action of acids on the nerves of taste. Acids act on the taste nerves in the tongue and give the taste of sourness; everything sour is an acid. Lemon juice, sour milk, and sour fruits are all too weak acids to injure clothes or skin, but their sour taste is a result of the acid in them acting on the nerves of taste.

Application 79. A girl wanted to make lemonade. She did not know which of two knives to use, a steel-bladed one or a silver-plated one. Which should she have used?

Application 80. A woman was going to put up some tomatoes. She needed something large to cook them in. She had a shiny new tin dish pan, an older enamelware dish pan, a galvanized iron water pail, and an old-fashioned copper kettle. Which would have been best for her to use?

Make a list of as many acids as you can think of.

Inference Exercise

Explain the following:

511. Sugar dissolves readily in *hot* coffee.
512. The sugar disappears, yet the coffee flavor remains and so does the sweetness of the sugar.
513. A tin spoon left overnight in apple sauce becomes black.
514. If one's clothes are on fire, rolling over on the ground is better than running.
515. Lemon juice bleaches straw hats.
516. Will-o'-the-wisps glow at night, deceiving travelers by their resemblance to moving lanterns.
517. Tomatoes should never be left in a tin can after it has been opened.
518. Boiled milk tastes different from ordinary milk.
519. Your hands become very cold after you have washed things in gasoline.
520. Wood decays more quickly when wet than when dry.

SECTION 55. *Bases.*

Why does strong soap make your face sting?

How is soap made?

"Contains no free alkali," "Will not injure the most delicate of fabrics," "99-44/100% pure,"—such phrases as these are used in advertising soaps. What is meant by 99-44/100% pure? What is free alkali? Why should any soap injure fabrics? What makes a soap "strong"?

The answer to all these questions is that there are some substances called *bases*, which are the opposites of acids, and some of which are as powerful as acids. Lye, ammonia, caustic soda, and baking and washing soda are common bases. The strong bases, like lye and caustic soda, are also called *alkalies*. If you want to see what a strong base—an alkali—will do to "the most delicate of fabrics," and to fabrics that are not so delicate, for that matter, try the following experiment:

Experiment 108. *To be done by the teacher.* If you get any alkali on your skin or clothes, wash it off immediately with vinegar or lemon juice.

Put half a teaspoonful of lye and a quarter of a cup of water into a beaker, a small pan, or an evaporating dish. Bring it to a *gentle* boil. Drop a small piece of woolen cloth and a small piece of silk cloth into it and let them boil gently for a couple of minutes. What happens to them? Try a piece of plain cotton cloth, and then a piece of cloth that is mixed wool and cotton or mixed silk and cotton. What happens to them? This is a very good test to determine whether any goods you buy are pure silk or wool, or whether there is a cotton thread mixed with them. Drop one end of a long hair into the hot lye solution. What happens to it? Drop a speck of meat or a piece of finger nail into it.

From this experiment you can readily see why lye will burn your skin and ruin your clothes. You can also see how it softens the food that sticks to the bottom of the cooking pan and makes the pan easy to clean. Lye is one of the strongest bases or alkalies in the world.

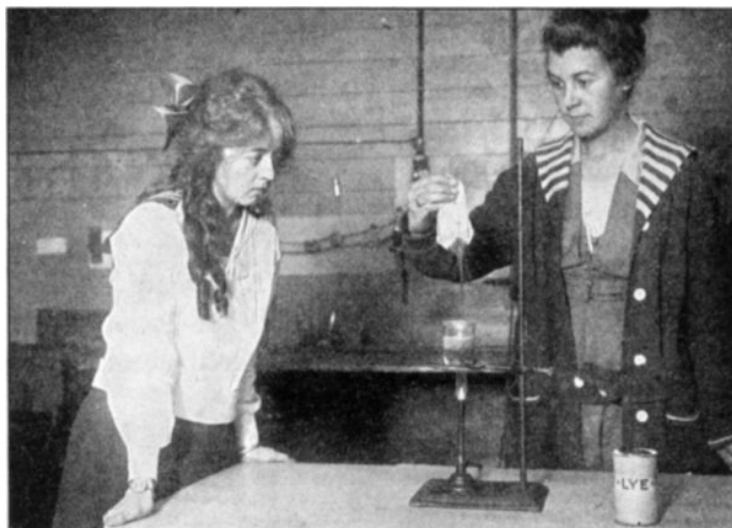

FIG. 184. The lye has changed the wool cloth to a jelly.

How soap is made. When lye and grease are boiled together, they form soap. You cannot very well make soap in the laboratory now, as the measurements must be exact and you need a good deal of strong lye to make it in a quantity large enough to use. But the fact that soap is made with oil, fat, or grease boiled with lye, or caustic soda, which is almost the same thing, shows why a soap must be 99-44/100% pure, or something like that, if it is not to injure "the most delicate fabric." If a little too much lye is used there will be free alkali in the soap, and it will make your hands harsh and sore and spoil the clothes you are washing. A "pure" soap is one with no free alkali in it. A "strong" soap is one that does have some free alkali in it; there is a little too much lye for the oil or fat, so some lye is left uncombined when the soap is made. This free alkali cleans things well, but it injures hands and clothes.

When the drainpipe of a kitchen sink is stopped up, you can often clear it by sprinkling lye down it, and then adding boiling water. *If you ever do this, stand well back so that no lye will spatter into your face; it sputters when the boiling water strikes it.* The grease in the drainpipe combines with the lye when the hot water comes down; then the soap that is formed is carried down the pipe, partly dissolved by the hot water.

When you sponge a grease spot with ammonia, the same sort of chemical action takes place. The ammonia is a base; it combines with the grease to form soap, and this soap rinses out of the cloth.

The litmus test. To tell what things are bases and what are acids, a piece of paper dyed with litmus is ordinarily used. Litmus is made from a plant (lichen). This paper is called *litmus paper*. Try the following experiment with litmus paper:

Experiment 109. Pour a few drops of ammonia, a base, into a cup. Into another cup pour a few drops of vinegar, an acid. Dip your litmus paper first into one, then into the

other, and then back into the first. What color does the vinegar turn it? the ammonia? Try lemon juice; diluted hydrochloric acid; a *very* dilute lye solution.

[pg 359]

This is called the *litmus test*. All ordinary acids, if not too strong, will turn litmus pink. All bases or alkalis will turn it blue. If it is already pink when you put it into an acid, it will stay pink, of course; if it is already blue when you put it into a base, it will stay blue. But if you put a piece of litmus paper into something that is neither an acid nor a base, like sugar or salt, it will still stay the same color. So, to test for a base, use a piece of litmus paper that is pink and see if it turns blue, or if you want to test for an acid, use blue litmus paper. Do this experiment:

Experiment 110. With pink and blue litmus paper, test the different substances named below to see which are acids and which are bases. Make a list of all the acids and another list for all the bases. Do not put down anything that is neither acid or base. You cannot be sure a thing is an acid unless it turns *blue* litmus *pink*. A piece of pink litmus would stay pink in an acid, but it would also stay pink in things that were neither acid nor base, like salt or water. In the same way you cannot be sure a thing is a base unless it turns *pink* litmus *blue*. Here is a list of things to try: 1, sugar; 2, orange; 3, dilute sulfuric acid; 4, baking soda in water; 5, alum in water; 6, washing soda in water; 7, ammonia; 8, dilute lye; 9, lemon juice; 10, vinegar; 11, washing powder in water; 12, sour milk; 13, cornstarch in water; 14, wet kitchen soap; 15, oil; 16, salt in water.

You may have to make the orange and sour milk test at home. You may take two pieces of litmus paper home with you and test anything else that you may care to. If you have a garden, try the soil in it. If it is acid it needs lime.

Application 81. A boy spilled some greasy soup on his best dark blue coat. Which of the following methods would have served to clean the coat? to sponge it (a) with cold water; (b) with water (hot) and ammonia; (c) with hot water and vinegar; (d) with concentrated nitric acid; to sprinkle lye on the spot and pour boiling water over it.

[pg 360]

Application 82. A woman scorched the oatmeal she was cooking for breakfast. When she wanted to wash the pan, she found that the blackened cereal stuck fast to the bottom. Which of the following things would have served best to loosen the burned oatmeal from the pan: lye and hot water, ammonia, vinegar, salt water, lemon juice?

Inference Exercise

Explain the following:

521. After clothes have been washed with washing soda or strong soap, they should be thoroughly rinsed. Otherwise they will be badly eaten as they dry.

522. Carbon will burn; oxygen will support combustion; yet carbon dioxide (CO₂), which is made of both these elements, will neither burn nor support combustion.

523. You can clean silver by putting it in hot soda solution in contact with aluminum.

524. When you stub your toe while walking, you tend to fall forward.

525. Electric lamps glow when you turn on the switch.

526. If you use much ammonia in washing clothes or cleaning, your hands become harsh and dry.

527. If a person swallows lye or caustic soda, he should immediately drink as much vegetable oil or animal oil as possible.

528. Water is made of hydrogen and oxygen; air is made of nitrogen and oxygen; yet while things will not burn in water, they will burn easily in air.

529. The backs of books that have been kept in cases for several years are not as bright colored as the side covers.

530. If you try to burn a book or magazine in a grate, only the outer pages and edges burn.

SECTION 56. *Neutralization.*

When you put soda in vinegar, what makes the vinegar less sour?

When we use sour milk for cooking, why does the food not taste sour?

[pg 361]

One of the most interesting and important facts about acids and bases is that if they are put together in the right proportions they turn to salt and water. Strong hydrochloric acid (HCl), for instance, will attack the skin and clothes, as you know; if you should drink it, it would kill you. Caustic soda (NaOH), a kind of lye, is such a strong alkali that it would dissolve the skin of your mouth in the way that lye dissolved hair in Experiment 108. Yet if you put these two strongly

poisonous chemicals together, they promptly turn to ordinary table salt (NaCl) and water (H₂O). Or, as the chemists write it:

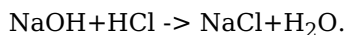

You can make this happen yourself in the following experiment, using the acid and base dilute enough so that they will not hurt you:

Experiment 111. Although strong hydrochloric acid and strong caustic soda are dangerous, if they are diluted with enough water they are perfectly harmless. You will find two bottles, one labeled "*caustic soda* (NaOH) diluted for tasting," and the other labeled "*hydrochloric acid* (HCl) diluted for tasting." From one bottle take a little in the medicine dropper and let a drop fall on your tongue. Taste the contents of the other bottle in the same way. *It is not usually safe to taste things in the laboratory. Taste only those things which are marked "for tasting."*

Now put a teaspoonful of the same hydrochloric acid into a clean evaporating dish. Lay a piece of litmus paper in the bottom of the dish. With a medicine dropper gradually add the dilute caustic soda (NaOH), stirring as you add it. Watch the litmus paper. When the litmus paper begins to turn blue, add the dilute caustic soda drop by drop until the litmus paper stays blue when you stir the mixture. Now add a drop or two more of the acid until the litmus turns pink again. Taste the mixture.

[pg 362]

Put the evaporating dish on the wire gauze over a Bunsen burner, and bring the liquid to a boil. Boil it gently until it begins to sputter. Then take the Bunsen burner in your hand and hold it under the dish for a couple of seconds; remove it for a few seconds, and then again hold it under the dish for a couple of seconds; remove it once more, and keep this up until the water has all evaporated and left dry white crystals and powder in the bottom of the dish. As soon as the dish is cool, taste the crystals and powder. What are they?

Is salt an acid or a base?

Whenever you put acids and bases together, you get some kind of salt and water. Thus the chlorine (Cl) of the hydrochloric acid (HCl) combines with the sodium (Na) of caustic soda (NaOH) to form ordinary table salt, sodium chloride (NaCl), while the hydrogen (H) of the hydrochloric acid (HCl) combines with the oxygen and hydrogen (OH) of the caustic soda (NaOH) to form water (H₂O). Chemists write this as follows:

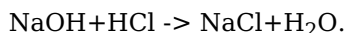

Why sour milk pancakes are not sour. It is because bases neutralize acids that you put baking soda with sour milk when you make sour milk pancakes or muffins. The soda is a weak base. The sour milk is a weak acid. The soda neutralizes the acid, changing it into a kind of salt and plain water. Therefore the sour milk pancakes or muffins do not taste sour.

In the same way a little soda keeps tomatoes from curdling the milk when it is added to make cream of tomato soup. It is the acid in the tomatoes that curdles milk. If you neutralize the acid by adding a base, there is no acid left to curdle the milk; the acid and base turn to water and a kind of salt.

[pg 363]

When you did an experiment with strong acid, you were advised to have some ammonia at hand to wash off any acid that might get on your skin or clothes. The ammonia, being a base, would immediately neutralize the acid and therefore keep it from doing any damage. Lye also would neutralize the acid, but if you used the least bit too much, the lye would do as much harm as the acid. That is why you should use a weak base, like ammonia or baking soda or washing soda, to neutralize any acid that spills on you. Then if you get too much on, it will not do any harm.

In the same way you were warned to have vinegar near at hand while you worked with lye. Strong nitric acid also would neutralize the lye, but if you happened to use a drop too much, the acid would be worse than the lye. Vinegar, of course, would not hurt you, no matter how much you put on.

Any acid will neutralize *any* base. But it would take a great deal of a weak acid to neutralize a strong base or alkali; you would have to use a great deal of vinegar to neutralize concentrated lye. In the same way it would take a great deal of a weak base to neutralize a strong acid; you would have to use a large amount of baking soda or ammonia to neutralize concentrated nitric acid.

Application 83. A woman was cleaning kettles with lye. Her little boy was playing near, and some lye splashed on his hand. She looked swiftly around and saw the following things: soap, oil, lemon, flour, peroxide, ammonia, iodine, baking soda, essence of peppermint. Which should she have put on the boy's hand?

[pg 364]

Application 84. A teacher spilled some nitric acid on her apron. On the shelf there were: hydrochloric acid, vinegar, lye, caustic soda, baking soda, ammonia, salt, alcohol,

kerosene, salad oil. Which should she have put on her apron?

Application 85. A boy had "sour stomach." His sister said, "Chew some gum." His aunt said, "Drink hot water with a little peppermint in it." His mother told him to take a little baking soda in water. His brother said, "Try some hot lemonade." Which advice should he have followed?

Application 86. Two women were bleaching a faded pair of curtains. The Javelle water which they had used was made of bleaching powder and washing soda. Before hanging the curtains out to dry, one of them said that she was afraid the Javelle water would become so strong as the water evaporated from the curtains that it would eat the curtains. They decided they had better rinse them out with something that would counteract the soda and lime in the Javelle water, and in the laundry and pantry they found: ammonia, blueing, starch, washing powder, soap, vinegar, and gasoline. Which of them, if any, would it have been well to put in the rinsing water?

Inference Exercise

Explain the following:

531. Solid pieces of washing soda disappear in hot water.
532. Greasy clothes put into hot water with washing soda become clean.
533. If you hang these clothes up to dry without rinsing them, the soda will weaken the cloth.
534. Lemon juice in the rinsing water will prevent washing soda from injuring the clothes.
535. If you hang them in the sun, the color will fade.
536. A piece of soot blown against them will stick.
537. A drop of oil that may spatter against them will spread.
538. The clothes will be easier to iron if dampened.
539. The creases made in ironing the clothes will reappear even if you flatten the creases out with your hand.
540. After they have been worn, washed, and ironed a number of times, clothes are thinner than they were when they were new.

[pg 365]

SECTION 57. *Effervescence.*

What makes baking powder bubble?

What makes the foam on soda water?

Did you ever make soda lemonade? It is easy to make and is rather good. Try making it at home. Here are the directions:

Experiment 112. Make a glass of ordinary lemonade (half a lemon, 1-1/2 teaspoonfuls of sugar; fill the glass with water). Pour half of this lemonade into another cup or glass. Into the remaining half glass stir half a teaspoonful of soda. Drink it while it fizzes. Does it taste sour?

When anything fizzes or bubbles up like this, we say that it *effervesces*. Effervescence is the bubbling up of a gas from a liquid. The gas that bubbled up from your lemonade was carbon dioxid (CO₂), and this is the gas that usually bubbles up out of things when they effervesce.

When you make bread, the yeast turns the sugar into carbon dioxid (CO₂) and alcohol. The carbon dioxid tries to bubble up out of the dough, and the bubbles make little holes all through the dough. This makes the bread light. When bread rises, it really is slowly effervescing.

How soda water is made. Certain firms make pure carbon dioxid (commercially known as *carbonic acid gas*) and compress it in iron tanks. These iron tanks of carbon dioxid (CO₂) are shipped to soda-water fountains and soda-bottling works. Here the compressed carbon dioxid is dissolved in water under pressure,—this is called "charging" the water. When the charged water comes out of the faucet in the soda fountains, or out of the spout of a seltzer siphon, or out of a bottle of soda pop, the carbon dioxid that was dissolved in the water under pressure bubbles up and escapes,—the soda water effervesces.

[pg 366]

Sometimes there is compressed carbon dioxid down in the ground. This dissolves in the underground water, and when the water bubbles up from the ground and the pressure is released, the carbon dioxid foams out of the water; it effervesces like the charged water at a soda

fountain.

But the most useful and best-known effervescence is the kind you got when you stirred the baking soda in the lemonade. Baking soda is made of the same elements as caustic soda (NaOH), with carbon dioxide (CO_2) combined with them. The formula for baking soda could be written NaOHCO_2 , but usually chemists put all of the O's together at the end and write it NaHCO_3 . Whenever baking soda is mixed with any kind of acid, the caustic soda part (NaOH) is used up in neutralizing the acid. This leaves the carbon dioxide (CO_2) part free, so that it bubbles off and we have effervescence. Baking soda mixed with an acid always effervesces. That is why sour milk muffins and pancakes are light as well as not sour. The effervescing carbon dioxide makes bubbles all through the batter, while the caustic soda (NaOH) in the baking soda neutralizes the acid of the sour milk.

[pg 367]



FIG. 185. Making a glass of soda lemonade.

Effervescence generally due to the freeing of carbon dioxide. Since baking soda is so much used in the home for neutralizing acids, people sometimes get the idea that whenever there is neutralization there is effervescence. Of course this is not true. Whenever you neutralize an acid with baking soda or washing soda, the carbon dioxide in the soda bubbles up and you have effervescence. But if you neutralize an acid with ammonia, lye, or plain caustic soda, there is not a bit of effervescence. Ammonia, lye, and plain caustic soda have no carbon dioxide in them to bubble out.

[pg 368]

Baking *powder* is merely a mixture of baking soda and dry acid (cream of tartar or phosphates in the better baking powders, alum in the cheap ones). These dry acids cannot act on the soda until they go into solution. As long as the baking powder remains dry in the can, there is no effervescence. But when the baking powder is stirred into the moist biscuit dough or cake batter, the baking powder dissolves; so the acid in it can act on the baking soda and set free the carbon dioxide.

In most cases it is the freeing of carbon dioxide that constitutes effervescence, but the freeing of any gas from liquid is effervescence. When you made hydrogen by pouring hydrochloric acid (HCl) on zinc shavings, the acid effervesced,—the hydrogen gas was set free and it bubbled up.

Stirring or shaking helps effervescence, just as it does crystallization. As the little bubbles form, the stirring or shaking brings them together and lets them join to form big bubbles that pass quickly up through the liquid. That is why soda pop will foam so much if you shake it before you pour it, or if you stir it in your glass.

Application 87. Explain why we do not neutralize the acid in sour milk gingerbread with weak caustic soda instead of with baking soda; why soda water which is drawn with considerable force from the fine opening at a soda fountain makes so much more foam than does the same charged water if it is drawn from a large opening, from which it flows gently; why there is *always* baking soda and dry acid in baking powder.

Application 88. A woman wanted to make gingerbread. She had no baking powder and no sour milk, but she had sweet milk and all the other articles necessary for making gingerbread. She had also baking soda, caustic soda, lemons, oranges, vanilla, salad oil, vinegar, and lye. Was there any way in which she might have made the

[pg 369]

gingerbread light without spoiling it?

Inference Exercise

Explain the following:

541. Harness is oiled to keep it flexible.
542. When you pour nitric acid on copper filings, there is a bubbling up of gas.
543. The flask or dish in which the action takes place becomes very hot.
544. The copper disappears and a clear green solution is left.
545. In making cream of tomato soup, soda is added to the tomatoes before the milk is, so that the milk will not curdle How does the soda prevent curdling?
546. The soda makes the soup froth up.
547. A wagon squeaks when an axle needs greasing.
548. Seidlitz powders are mixed in only *half* a glass of water.
549. The work of developing photographs is all done with a ruby light for illumination.
550. Coal slides forward off the shovel into a furnace when you stop the shovel at the furnace door.

[pg 370]

CHAPTER TWELVE

ANALYSIS

SECTION 58. *Analysis.*

How can people tell what things are made of?

If it were not for chemical analysis, most of the big factories would have to shut down, much of our agricultural experimentation would stop, the Pure Food Law would be impossible to enforce, mining would be paralyzed, and the science of chemistry would almost vanish.

Analysis is finding out what things are made of. In order to make steel from ore, the ore has to be analyzed; and factories could not run very well without steel. In order to test soil, to test cow's milk, or to find the food value of different kinds of feed, analysis is essential. As to the Pure Food Law, how could the government find out that a firm was using artificial coloring matter or preservatives if there were no way of analyzing the food? In mining, the ore must be assayed; that is, it must be analyzed to show what part of it is gold, for instance, and what part consists of other minerals. Also, the analysis must show what these substances are, so that they can be treated properly. And the science of chemistry is largely the science of analyzing—finding out what things are made of and how they will act on each other.

The subject of chemical analysis is extremely important. But in this course it is impossible and unnecessary for you to learn to analyze everything; the main thing is for you to know what analysis is and to have a general notion of how a chemist analyzes things.

[pg 371]

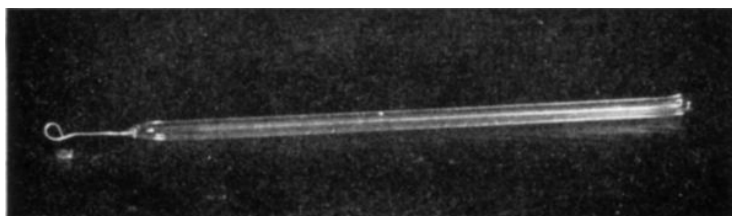

FIG. 186. The platinum loop used in making the borax bead test.

When you tested a number of substances with litmus paper to find out which of them were acids, you were really doing some work in chemical analysis. Chemists actually use litmus paper in this way to find out whether a substance is an acid or a base.

The borax bead test. This is another chemical test, by which certain substances can be recognized:

Experiment 113. Make a loop of wire about a quarter of an inch across, using light-weight platinum wire (about No. 30). Seal the straight end of the wire into the end of a piece of glass tubing by melting the end of the tube around the wire.

Hold the loop of wire in the flame of a Bunsen burner for a few seconds, then dip the looped end in borax powder. Be careful not to get borax on the upper part of the wire or on the handle. Some of the borax will stick to the hot loop. Hold this in the flame until it melts into a glassy bead in the loop. You may have to dip it into the borax once or twice more to get a good-sized bead.

When the bead is all glassy, and while it is melted, touch it lightly to *one small grain* of one of the chemicals on the "jewel-making plate." This jewel-making plate is a plate with six small heaps of chemicals on it. They are: manganese dioxide, copper sulfate, cobalt chloride, nickel salts, chrome alum, and silver nitrate. Put the bead back into the flame and let it melt until the color of the chemical has run all through it. Then while it is still melted, shake the bead out of the loop on to a clean plate. If it is dark colored and cloudy, try again, getting a still smaller grain of the chemical. You should get a bead that is transparent, but clearly colored, like an emerald, topaz, or sapphire.

[pg 372]



FIG. 187. Making the test.

Repeat with each of the six chemicals, so that you have a set of six different-colored beads.

This is a regular chemical test for certain elements when they are combined with oxygen. The cobalt will always change the borax bead to the blue you got; the chromium will make the bead emerald green or, in certain kinds of flame, ruby red; etc. If you wanted to know whether or not certain substances contained cobalt combined with oxygen, you could really find out by taking a grain on a borax bead and seeing if it turned blue.

[pg 373]

The hydrochloric acid test for silver. The experiment in which you tested the action of light in effecting chemical change, and in which you made a white powder or precipitate in a silver nitrate solution by adding hydrochloric acid (page 327), is a regular chemical test to find out whether or not a thing has silver in it. If any silver is dissolved in nitric acid, you will get a precipitate (powder) when hydrochloric acid is added. Make the test in the following experiment:

Experiment 114. Use distilled water all through this experiment if possible. First wash two test tubes and an evaporating dish thoroughly, rinsing them several times. Into one test tube pour some nitric acid diluted 1 to 4. Heat this to boiling, then add a few drops of hydrochloric acid diluted 1 to 10. Does anything happen? Pour out this acid and rinse the dish thoroughly. Now put a piece of silver or anything partly made of silver into the bottom of the evaporating dish. Do not use anything for the appearance of which you care. Cover the silver with some of the dilute nitric acid, put the dish over the Bunsen burner on a wire gauze, and bring the acid to a gentle boil. As soon as it boils, take the dish off, pour some clean, cold water into it to stop the action, and pour the liquid off into the clean test tube. Add a few drops of the dilute hydrochloric acid to the liquid in the test tube. What happens? What does this show must have been in the liquid?

You can detect very small amounts of silver in a liquid by this test. It is a regular test in chemical analysis.

The iodine test for starch. A very simple test for starch, but one that is thoroughly reliable, is the following:

Experiment 115. Mix a little starch with water. Add a drop of iodine. What color does the starch turn? Repeat with sugar. You can tell what foods have starch in them by testing them with iodine. If they turn black, blue, or purple instead of brown, you may be sure there is starch in them. And if they do not turn black, blue, or purple, you can be equally sure that they have no starch in them. Some baking powders contain starch to keep them dry. Test the baking powder in the laboratory for starch. Often a little

[pg 374]

cornstarch is mixed with powdered sugar to keep it from lumping. Test the powdered sugar in the laboratory to see if it contains starch.



FIG. 188. The white powder that is forming is a silver salt.

Test the following or any other ten foods to see if any of them are partly made of starch: salt, potatoes, milk, meat, sausage, butter, eggs, rice, oatmeal, cornmeal, onions.

[pg 375]

The limewater test for carbon dioxid. In crowded and badly ventilated rooms carbon dioxid in unusual amounts is in the air. It can be detected by the limewater test.

Experiment 116. Pour an inch or two of limewater into a glass. Does it turn milky? Pump ordinary air through it with a bicycle pump. Now blow air from your lungs through a glass tube into some fresh limewater until it turns milky. By this test you can always tell if carbon dioxid (CO_2) is present.



FIG. 189. The limewater test shows that there is carbon dioxid in the air.

[pg 376]

Carbon dioxid turns limewater milky as it combines with the lime in the limewater to make tiny particles (a precipitate) of limestone. If you pour seltzer water or soda pop into limewater, you get the same milkiness, for the bubbles of carbon dioxid in the charged water act as the carbon dioxid in your breath did. If you pumped enough air through the limewater you would produce

some milkiness in it, for there is always some carbon dioxide in the air.

The purpose of these experiments is only to give you a general notion of how a chemist analyzes things,—by putting an unknown substance through a series of tests he can tell just what that substance contains; and by accurately weighing and measuring everything he puts in and everything he gets out, he can determine how much of each thing is present in the compound or mixture. To learn to do this accurately takes years of training. But the men who go through this training and analyze substances for us are among the most useful members of the human race.

Inference Exercise

Explain the following:

551. A little soda used in canning an acid fruit will save sugar.
552. The fats you eat are mostly digested in the small intestine, where there is a large excess of alkali.
553. The dissolved food in the liquid part of the blood gets out of the blood vessels and in among the cells of the body, and it is finally taken into the cells through their walls.
554. Ammonia takes the color out of delicate fabrics.
555. Dishes in which cheese has been cooked can be cleaned quickly by boiling vinegar in them.
556. Prepared pancake flour contains baking powder. It keeps indefinitely when dry, but if the box gets wet, it spoils.
557. When water or milk is added to prepared pancake flour to make a batter, bubbles appear all through it.
558. When a roof leaks a *little*, a *large* spot appears on the ceiling.
559. Gasoline burns quietly enough in a stove, but if a spark gets into a can containing gasoline vapor, there is a violent explosion.
560. Turpentine will remove fresh paint.

[pg 377]

General Review Inference Exercise

Explain the following:

561. We can remove fresh stains by pouring boiling water through them.
562. A ship can be more heavily laden in salt water than in fresh water.
563. Water flies off a wet dog when he shakes himself.
564. In cooking molasses candy, baking soda is often added to make it lighter.
565. An egg will not stand on end.
566. Women who carry bundles on their heads stand up very straight.
567. To get all crayon marks off a blackboard, the janitor uses *vinegar* in water.
568. Sunlight makes your skin darker.
569. Water puts out a fire.
570. You get a much worse shock from a live wire when your hands are wet than when they are dry.
571. Stone or brick buildings are cool in summer but warm in winter.
572. If you take the handle off a faucet, it is almost impossible to turn the valve with your fingers.
573. Sparks fly from a grindstone when you are sharpening a knife.
574. Violin strings are spoiled by getting wet.
575. The oxygen of the air gets into the blood from the lungs, although there are no holes from the blood vessels into the lungs.
576. You push a button or turn a key switch and an electric lamp lights.

577. A rubber comb, rubbed on a piece of wool cloth, will attract bits of paper to it.
578. People whose eyes no longer adjust themselves have to have "reading glasses" and "distance glasses" to see clearly.
579. When you look through a triangular glass prism, things appear to be where they are not.
580. Lye and hot water poured down a clogged kitchen drainpipe clear out the grease.
581. You can draw on rough paper with charcoal.
582. When little children get new shoes, the soles should be scratched and made rough.
583. You can get your face very clean by rubbing cold cream into it, then wiping the cold cream off on a towel or cloth.
584. Soft paper blurs writing when you use ink.
585. Water will flow over the side of a pan through a siphon, if the outer end of the siphon is lower than the surface of the water in the pan.
586. There is a loud noise when a gun is fired.
587. Colored cloths should be matched in daylight, not in artificial light.
588. Lamp chimneys are made of *thin* glass.
589. When you sweep oiled floors, no dust flies around the room.
590. The ocean is salty, while lakes are usually fresh.
591. A glass gauge on the side of a water tank shows how high the Water in the tank is.
592. You burn your hand when you touch a hot stove.
593. Pounding a piece of steel held horizontally over the earth and pointing north and south will make it become a magnet.
594. When only one side of a sponge is in water, the sponge gradually gets soft all over.
595. If we breathe on a cold mirror, a fine mist collects on it.
596. Butter is kept in cool places.
597. Water will boil more quickly in a covered pan than in an open one.
598. Mucilage, glue, and paste all become hard and dry after being spread out on a surface for a while.
599. You cannot see things clearly through a dusty window.
600. In making fire grates it is necessary to have the bars free to move a little.

APPENDIX

A. THE ELECTRICAL APPARATUS

For giving children a practical understanding of such laws of electricity as affect everybody, the following simple apparatus is invaluable. It is the electrical apparatus referred to several times in the text. The only part of it that is at all difficult to get is the nichrome resistance wire. There is a monopoly on this and each licensee has to agree not to sell it. It can be bought direct from the manufacturer by the school board if a statement accompanies the order to the effect that it is not to be used in any commercial devices, nor to be sold, but is for laboratory experimentation only. The manufacturers are Hoskins Manufacturing Company, Detroit, Michigan.

The following diagram will make the connections and parts of the electrical apparatus clear:

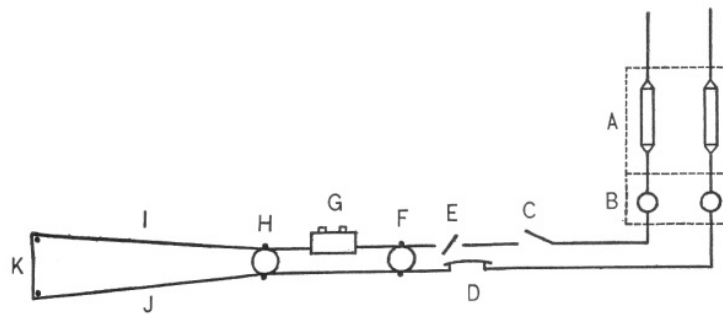

FIG. 190. Electrical apparatus: At the right are the incoming wires. Dotted lines show outlines of fuse block. A, 2 cartridge fuses, 15 A; B, 2 plug fuses, 10 A; C, knife switch; D, fuse gap; E, snap switch; F, H, lamp sockets; G, flush switch; I, J, K, nichrome resistance wire, No. 24 (total length of loop, 6 feet), passing around porcelain posts at left.

The flush switch (*G*) should be open at the bottom for inspection,—remove the back. The snap switch (*E*) should have cover removed so that pupils can see exactly how it works.

[pg 380]

The fuse gap (*D*) consists either of two parts of an old knife switch, the knife removed, or of two brass binding posts. Across it a piece of 4-ampere fuse wire is always kept as a protection to the more expensive plug and cartridge fuses. Between the resistance wire (*I, J, K*) and the wall should be either slate or sheet asbestos, double thickness. Under the fuse gap the table should be protected by galvanized iron so that the melted bits of fuse wire can set nothing on fire when the fuse wire burns out.

B. CONSTRUCTION OF THE CIGAR-BOX TELEGRAPH

The "cigar-box telegraph" shown on page 381 is made as follows: An iron machine bolt (*A*) is wound with about three layers of No. 24 insulated copper magnet wire, the two ends of the wire (*B, B*) projecting. The threaded end of the bolt (*C*) is not wound. A nut (*D*) is screwed on the bolt as far down as the wire wrapping. The threaded end is then pushed up through the hole in the top of the cigar box as that stands on its edge. Another nut (*E*) is then screwed on to the bolt, holding it in position. The bolt can now be raised or lowered and tightened firmly in position by adjusting the two nuts (*D* and *E*), one above and one below the wood.

A screw eye (*F*), large enough to form a rest for the head of another machine bolt (*G*), is screwed into the back of the box about three fourths of an inch below the head of the suspended bolt (*A*). Two or three inches away, at a slightly higher level, another screw eye (*H*) is screwed into the back of the cigar box. This screw eye must have an opening large enough to permit an iron machine bolt (*G*) to pass through it easily. A nut (*I*) is screwed down on the threaded end of a machine bolt until about an inch of the bolt projects beyond the nut. This projecting part of the bolt is then passed through the screw eye (*H*) and another nut (*J*) screwed on to it to hold it in place. This nut must not be so tight as to prevent the free play of the bolt as its head rises and falls under the influence of the vertical bolt. The head of the horizontal bolt rests upon the screw eye which is immediately below the head of the suspended bolt. You therefore have the wrapped bolt hanging vertically from the top of the box, with its head just over the head of the horizontal bolt. There should be about one quarter inch of space between the heads of the two bolts. An electric current passing through the wires of the vertical bolt will therefore lift the head of the horizontal bolt, which will drop back on to the screw eye when the circuit is broken.

[pg 381]

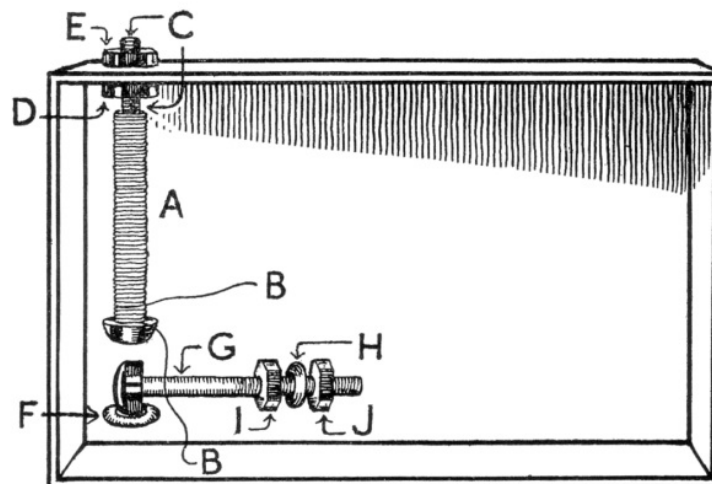

Fig. 191. The cigar-box telegraph.

INDEX

An asterisk (*) indicates use of one or more illustrations in connection with reference to which appended.

[A](#) [B](#) [C](#) [D](#) [E](#) [F](#) [G](#) [H](#) [I](#) [K](#) [L](#) [M](#)
[N](#) [O](#) [P](#) [Q](#) [R](#) [S](#) [T](#) [U](#) [V](#) [W](#) [Y](#) [Z](#)

- Acetylene, carbon and hydrogen in, [315](#).
- Acids, [351](#) ff.;
- action of, on metals, [351](#)-353*;
 - action of, on cloth, [354](#)*;
 - action of, on nerves of taste, [354](#)-355;
 - distinguished from bases by litmus test, [358](#)-359;
 - neutralization of, by bases, [360](#)-364.
- Action and reaction, law of, [77](#)-81*.
- Adhesion, [39](#), [41](#)-44;
- cohesion, capillary attraction, and, [47](#).
- Air, cooling of, on expanding, [95](#)-96;
- liquid, [97](#);
 - heat carried by, by convection, [118](#)-119;
 - absorption of light by, [169](#);
 - sound produced by vibrations of, [174](#)-181*;
 - pitch due to rapidity of vibrations of, [186](#);
 - water vapor in, [275](#)-280*;
 - a mixture and not a compound, [309](#);
 - part taken by, in making automobile go, [344](#);
 - limewater test for carbon dioxide in, [375](#).
- Air pressure, [10](#) ff., [14](#)*;
- height water is forced up by, in vacuum, [19](#);
 - high and low, [20](#), [282](#);
 - winds caused by, [20](#)-21.
- Air pump, [14](#)*, [15](#).
- Alcohol, boiling of, [112](#);
- distilling, [113](#)*-114.
- Alkali, [356](#);
- in soap, [357](#)-358.
- Alloys, definition of, [310](#).
- Alternating current, defined, [211](#)-212.
- Alum crystals, experiment with, [265](#)-266*.
- Aluminum, an element, [299](#).
- Alum in water, testing with litmus paper, [359](#).
- Amber, electricity produced by rubbing with silk, [196](#).
- Ammonia, example of a common base, [356](#);
- action of, in cleaning cloth, [358](#);
 - litmus test of, [359](#);
 - neutralization of acid by, [363](#).
- Ampere, defined, [246](#).
- Analysis, chemical, [370](#)-376.
- Aneroid barometer, [285](#)*.
- Arc, the electric, [233](#)-240*.
- Atoms, description of, [196](#);
- electrons and, [197](#);
 - everything in the world made of, [310](#)-311;
 - in molecules, [311](#).
- Aurora Borealis, cause of, [193](#).
- Automobile, reason for cranking, [210](#);
- how made to go, [344](#)-345.
- Automobile races, overcoming of centrifugal force in, [75](#)*.
- Automobile tires, reason for wearing of, [80](#);
- blow-outs of, [348](#).
- Baking powder, chemical change by solution shown by, [349](#)-350;
- elements of which made, [367](#)-368.
- Baking soda, a common base, [356](#);
- testing with litmus paper, [359](#);
 - neutralization of sour milk by, in cooking, [362](#);

carbon dioxide in, [366-367](#).
 Ball bearings, used to diminish friction, [54-55](#).
 Balloon, expansion of, [17-18](#), [109*](#);
 reason for rising of, [26](#);
 filling of, with hydrogen, [301-304*](#).
 Barometer, use of, [280-285*](#).
 Bases, substances called, [355-358](#);
 litmus test for distinguishing from acids, [358-359](#);
 neutralization of, by acids, [360-364](#).
 Batteries, electric, [203-205*](#);
 different kinds of, [205*-207*](#);
 general principle of all, [206](#).
 Bell, electric battery for ringing, [204-205*](#);
 working of electric, [255*](#).
 Bending of light (refraction), [136-141*](#).
 Black, the absence of light, [164](#).
 Bleaching, process of, [326-327](#).
 Blow-out of tire, a real explosion, [348](#).
 Blue-flame heaters, [319](#).
 Blueness of sky, reason for, [169](#).
 Blueprints, making of, [330-331](#).
 Boiling and condensing, [107-115*](#).
 Borax bead test, [371*-372*](#).
 Brass, an alloy, [310](#).
 Bread making, chemical action in, [365](#).
 Breath, cause of visibility of, on cold days, [288](#), [289*](#).
 Bronze, an alloy, [310](#).
 Burning, explanation of, [308](#), [312-313](#).

 Calcium chlorid, [114](#).
 Camera, lens of, [143](#), 148;
 human eye as a small, [151*-153](#);
 explanation of, [327-332](#).
 Capillary attraction, [36*-40](#);
 difference between adhesion, cohesion, and, [47](#).
 Carbon, in electric battery, [203-206](#);
 resistance of, to electric current, [231](#);
 an element, [293](#), [299](#);
 one of chief elements in fuel, [315-316](#).
 Carbon dioxide, in seltzer siphon, [17](#);
 produced by joining of carbon with oxygen, [315](#);
 combining of water and, by plants, [332-333](#);
 releasing of, in baking powder, [349-350](#);
 bubbling of, in effervescence, [365-366](#);
 in soda water, springs, and baking soda, [366-367](#);
 limewater test for, [375-376](#).
 Carbonic acid gas, commercial name for pure carbon dioxide, [365-366](#).
 Cat's hairs, static electricity in, [201](#).
 Caustic soda, a common base, [356](#).
 Center of weight, [30-33*](#).
 Centrifugal force, [5](#), [72-74](#);
 law of, [74-75](#).
 Charcoal, production of, [316](#).
 Charging water with carbon dioxide, [366](#).
 Chemical analysis, [370-376](#).
 Chemical change, and energy, [293](#) ff.;
 burning (oxidation), [312-322](#);
 caused by heat, [323-325](#);
 caused by light, [326-335](#);
 caused by electricity, [335-339](#);
 energy released by, [340-341](#);
 helped by solution, [349-351](#).
 Chemical equations, [297-299](#).
 Chlorine, an element, [299](#).
 Chlorophyll in plants, work of, [332](#).
 Cigar-box telegraph, construction of, [249*](#), [380-381*](#).
 Circuits, electric, [219-220*](#);

breaking and making, [220-221](#);
 connecting in parallel, [221-223*](#);
 grounded, [225-229*](#);
 short, [240-245*](#).
 Cloth, action of acids on, [354*](#);
 action of an alkali on, [356](#), [357*](#).
 Clouds, how formed, [277-278](#).
 Coal, carbon and hydrogen in, [315](#).
 Cohesion, [39](#), [44*](#)-49.
 Cold, caused by expansion, [94](#);
 is the absence of heat, [95](#), [120](#).
 Color, [161-172*](#).
 Comb, electricity produced by rubbing, [197-198](#).
 Compass, use of, [190-195*](#).
 Complete electric circuits, [219-224*](#).
 Compounds, how elements hide in, [300](#);
 definition of, [308-309](#);
 mixtures distinguished from, [309-310](#).
 Concave mirrors, [154*](#), [155*](#), [157](#);
 magnification by, [157](#);
 in reflecting telescopes, [157](#).
 Conduction, of heat, [116-118](#);
 of electricity, [213-218](#).
 Conductors of electricity, good and poor, [213](#).
 Conduits for electric wires, [237](#).
 Conservation of energy, [57](#) ff.
 Convection, carrying of heat by, [118-119](#).
 Convex lens, [148-149*](#);
 in microscope, [155-157*](#);
 in telescope, [157](#).
 Cooling from expansion, [94-96](#).
 Coolness at night and in winter, [127-128](#).
 Copper, a good conductor of electricity, [215](#);
 an element, [299](#);
 nickel plating of, [336-339*](#);
 etching of, with acid, [352*](#)-353.
 Copper nitrate, salt called, [353](#).
 Cream, separating from milk, by centrifugal force, [75-76](#).
 Crystals, formation of, [265-268](#).
 Cylinder of engine, [344*](#).

 Dead Sea, reason for salt in, [104-105*](#).
 Decay, a kind of oxidation, [313](#).
 Dew, [275](#);
 how formed, [287](#).
 Dictaphone, working of, [175](#), [178](#), [179*](#).
 Diffusion, [268-274](#);
 of light, [158-161](#).
 Direct-current electricity, [211-212](#).
 Distilling of liquids, [112-115*](#).
 Doorbell, electric battery for ringing, [204-205](#).
 "Down," meaning of word, [4](#).
 Drainpipe, cleaning of, with lye, [358](#).
 Dry-cell battery, [206*](#).
 Dust, reason for clinging to walls, [43-44](#).
 Dynamite, [343*](#);
 making of, [347](#).
 Dynamo, how electric current is made to flow by, [207*](#)-210*.

 Earth, magnetism of, [190-195](#).
 Easy circuit, a short circuit an, [244-245](#).
 Echoes, explanation of, [183-185](#).
 Effervescence, process of, [365](#);
 generally due to freeing of carbon dioxide, [367*](#)-368;
 helped by stirring or shaking, [368](#).
 Elasticity, [82-86](#);
 of form distinguished from elasticity of volume, [86-87](#).

Electrical apparatus, [216-217*](#), [222-223*](#);
description of, [379-380](#).

Electric arc, the, [233*](#)-240.

Electric battery, the, [203-206*](#).

Electricity, magnetism and, [190](#) ff.;

- static, [196-202](#);
- negative and positive charges of, [198*](#)-200;
- action of, in thunderstorms, [200-201](#);
- flowing, [203](#) ff.;
- flowing of, in dynamo, [207-210](#);
- alternating and direct-current, [211-212](#);
- conduction of, [213*](#)-218;
- chemical change caused by, [335-339](#).

Electric lamps, vacuums in, [12*](#), [317](#);

- incandescent, [125](#);
- gas-filled, [317](#).

Electric motors, [256*](#)-257*.

Electrolysis apparatus, [294-295*](#).

Electromagnets, [247-257*](#).

Electrons, [193](#);

- description of, [197](#);
- number of, in negative and in positive charges, [198-200](#).

Elements, defined, [293](#);

- chemists' abbreviations of, [297-299](#);
- list of common, [299-300](#);
- hiding of, in compounds, [300-301](#).

Emulsion, defined, [261](#);

- difference between solution and, [263](#).

Energy released by chemical change, [340-341](#).

Engine, working of cylinder and piston of, [344*](#).

Ether, carrying of heat and light by, [124-125](#);

- light as waves of, [163-164](#).

Ether waves, [124-125](#), [163-164](#).

Evaporating dish, [101*](#).

Evaporation, [100-106*](#);

- part taken by, in formation of clouds, rain, and dew, [277](#).

Expansion, caused by heat, [88-93](#);

- cooling from, [94-96*](#).

Expansion ball and ring experiment, [91*](#)-92.

Explosions, use of, [342*](#) ff.;

- automobiles made to go by succession of, [344-345](#);
- cause of, [345](#);
- shooting of guns caused by, [345-346](#).

Explosives, manufacture of, [347](#).

Extension lights, [238](#).

Eye, lens of, [142](#);

- section of, [151*](#);
- working of, [151*](#)-153.

Fading, process of, [326-327](#).

Filament of incandescent lamp, [125](#).

Fire engines, need of, to force water high, [9](#).

Fire extinguishers, action of, [317](#).

Fires, caused by electric arcs, [236](#);

- putting out of, by water, [317](#).

See Burning.

Flames, formation of, [318](#).

Floating, sinking and, [23-28](#).

Focus of light, [142*](#)-149*.

Fogs, cause of, [288](#).

Food, light necessary to production of, [332-333](#).

Force, overcoming of extra motion by, in lever, [63-64*](#);

- reason for, of steam, [110](#).

Forecasters, weather, [282-285](#).

Form, elasticity of, [86-87](#).

Freckles, cause of, [327](#).

Freezing and melting, [96-99](#).

Friction, [49-55*](#);
 electricity produced by, [197-198*](#).

Frost, [97](#), [275](#);
 explanation of, [287](#).

Fuel, chief elements in, [315-316](#).

Fulcrum of lever, [59-60*](#).

Fuse gap, the, [241*](#), [379*](#).

Fuses, short circuits and, [240-245](#).

Gas, cooling of, on expanding, [94-95](#);
 carbon and hydrogen in, [315](#);
 used for filling electric lamps, [317-318](#);
 will not burn until hot enough, [323-324](#);
 an explosion the sudden release of a confined, [348](#).

Gases, diffusion of, [269-271](#);
 as elements, [293-294](#).

Gas heaters, action of, [319](#), [321*](#), [322*](#).

Gasoline, evaporation of, [103](#);
 boiling of, [112](#);
 distilled from petroleum, [114](#);
 elements of, [315](#);
 action of, in making automobiles go, [344-345](#).

Geysers, cause of, [110](#).

Glass, a poor conductor of heat, [118](#);
 used as insulator of electricity, [215](#).

Glowworms, reason for glowing of, [341-342](#).

Gold, an element, [293](#), [299](#);
 plating of, [339](#).

Gravitation, defined, [3](#).

Gravity, [1](#);
 pull of, opposed to pull of adhesion, [42-43](#).

Grease, friction diminished by, [53-54](#);
 combined with lye to form soap, [357](#).

Great Salt Lake, reason for salt in, [104-105](#).

Greeks, early knowledge of electricity possessed by, [196](#).

Green color of water, reason for, [169-171*](#).

Grounded circuits, [225-229*](#).

Gun, shooting of, caused by explosion, [345-346](#).

Gunpowder, action of, in shooting of a gun, [345-346](#);
 how made, [347](#).

Hail, explanation of, [286](#).

Heat, a result of friction, [53](#);
 is the motion of molecules, [90](#);
 not caused by expansion, [94-95](#);
 cold is absence of, [95](#), [120](#);
 required to evaporate liquids, [102-103](#);
 conduction of, [116-118](#);
 carried by air, by convection, [118-119](#);
 radiation of, [122-128](#);
 of incandescent lamp, [125-126](#);
 brought to focus by convex lens, [149](#);
 chemical change caused by, [323-325](#).

Heaters, hot-water, [120*](#);
 electric, [230](#), [232](#);
 gas, [319](#), [321*](#), [322*](#).

Heat waves, cause of, [141](#).

Hydrochloric acid, getting hydrogen from, [301-304](#);
 testing for silver with, [373](#).

Hydrofluoric acid, [351](#).

Hydrogen, an element, [294](#), [299](#);
 in water, [295-296](#);
 experiments with, [301-304*](#);
 one of chief elements in fuel, [315-316](#);
 part taken by, in burning, [312-319](#).

Ice, slight friction of, [52*](#);

action of molecules in, on freezing and melting, [96-97](#);
reason for floating of, [98-99](#).
Incandescence, defined, [125](#).
Incandescent lamps, [125-126](#);
number of electrons in, [197](#);
working of, [229-232](#).
Inertia, [66-71](#);
definition of, [70](#).
Insulators, of heat, [118](#);
of electricity, [213](#);
substances used as, [215](#).
Iodine, an element, [299](#);
testing with, for starch, [373-374](#).
Iron, a good conductor of heat, [118](#);
an element, [299](#).
Irons, electric, [229*](#), [230](#), [232](#).
Iron salt, formed by lemon juice on steel, [353](#).
Iron ships, reason for floating, [24*](#)-26.

Kerosene, boiling of, [112](#);
distilled from petroleum, [114](#);
carbon and hydrogen in, [315](#).

Laughing gas, [309](#).
Lava in volcanoes, [110](#).
Lead, an element, [299](#).
Lead pencils, arc light from, [233*](#)-234*.
Leaning Tower of Pisa, [29*](#)-30.
Lemon juice, action of, on silver and on steel, [353](#);
litmus test of, [359](#).
Lens, of eye, [142](#), [151*](#)-153;
of camera, [143](#), [149*](#), [328](#);
convex, [148-149](#);
concave, [149*](#);
in telescope, [157](#).
Levers, [57-65*](#).
Light, radiation of, [122](#), [123*](#)-128;
reflection of, [129-135*](#);
refraction of, [136*](#)-141;
focus of, [142-149*](#);
brought to focus by convex lens, [149](#);
diffusion of, [158-161*](#);
color a kind of, [162](#);
speed of, [182](#);
chemical change caused by, [326-335](#);
and manufacture of food in plants, [332-333](#).
Lightning, cause of, [200-201](#).
Limewater test for carbon dioxide, [375*](#)-376.
Liquid air, [97](#), [112](#).
Liquids, absorption of, [36-40](#);
diffusion in, [272](#).
Litmus paper, experiments with, [358-359](#).
Litmus test, the, [358-359](#).
Lye, a common base, [356](#);
experiment with, [356](#);
soap made from, [357](#);
used for clearing out drainpipe, [358](#);
neutralization of, by acids, [363](#).

Machinery, oiling of, to decrease friction, [53-54](#).
Magdeburg hemispheres, [15](#), [16*](#)-17.
Magnetism, [190](#) ff.
Magneto, of automobile, [210](#), [211*](#);
of old-fashioned telephone, [210-211](#).
Magnets, [190-195*](#).
Magnification, [150-157](#);
by concave mirror, [157](#).

Magnifying glass, convex lens in, [149](#);
 operation of, [150-156*](#).

Manganese dioxid, an essential in explosives, [347](#).

Megaphone, working of, [184](#).

Melting, freezing and, [96-99](#).

Membrane, diffusion through a, [272](#).

Mercury, cohesion of, [47-48*](#);
 use of, in thermometer, [89*](#), [90-91](#);
 an element, [299](#).

Mercury-vapor lamps, [167-168*](#), [172](#).

Metals, good conductors of heat, [118](#);
 good conductors of electricity, [215](#);
 as elements, [310](#);
 plating of, [336-339*](#);
 action of acids on, [351-353](#).

Microscope, [88](#);
 working of, [155-157*](#).

Mirrors, concave, [154*](#), [155*](#), [157](#).

Mixtures, distinguished from compounds, [309-310](#).

Molecular attraction, [36](#) ff.

Molecules, pull of, on each other, [46-47](#);
 explanation of, [88-89](#);
 heat defined as the motion of, [90](#);
 action of, in evaporation, [102-103*](#);
 action of, in boiling water, [107](#);
 action of, in conduction of heat, [117](#);
 action of, in radiation of heat and light, [125](#);
 action of, in magnetizing, [194*](#)-195;
 made up of atoms, [196](#), [310](#);
 mingling of, [259](#) ff.;
 action of, in formation of clouds, rain, and dew, [277](#).

Moon, cause of ring around, [131](#).

Morse telegraph code, [253](#).

Motion-picture machines, lenses of, [143](#), [148](#).

Motor, the electric, [255-257*](#).

Mountains, rainfall on, [286-287](#).

Musical instruments, pitch of, [185-187*](#), [188](#);
 vibrating devices of, [188](#).

Nail plug, the, [241*](#), [379*](#).

Needle, magnetizing of, [192*](#), [193*](#)-195.

Negative charges of electricity, [198-200](#).

Neutralization of acids and bases, [360-364](#).

Niagara Falls, electricity generated by, [210](#).

Nickel, an element, [299](#).

Nickel-plating copper, process of, [336-339*](#).

Night, reason for coolness at, [127-128](#).

Nitric-acid, etching copper with, [352*](#)-353;
 action of, on cloth, [354*](#).

Nitrogen, an element, [299](#);
 a non-burning gas, [308](#);
 used in electric lamps, [317](#).

Northern Lights, cause of, [193](#).

Ocean, why salt, [104-105](#).

Oil, reason for floating of, [26-27](#);
 decreasing of friction by, [53-54](#);
 softening due to, [290-292](#);
 carbon and hydrogen in crude, [315](#);
 why water will not put out burning, [317](#).

Oil heaters, action of, [319](#).

Orange, litmus test of, [359](#).

Osmosis, process called, [272-274](#).

Osmotic pressure, [272-273*](#).

Oxidation, [312-322](#).

Oxygen, an element, [293](#), [299](#);
 an element of water, [295-296](#);

experiments in getting, from two solids, [305-308*](#);
function of, in burning, [308](#);
part taken by, in burning (oxidation), [312-313](#);
released in manufacture of plant food, [333-335](#);
a compound of, an essential in explosives, [347](#).

Pancakes, made from sour milk, [362](#).

Paper, carbon and hydrogen in, [315](#).

Paraffine, production of, [114](#).

Parallel circuits, [221-223*](#).

Peat, carbon and hydrogen in, [315](#).

Pencils, making arc light with, [233*-234*](#).

Periscope experiment, [134-135*](#).

Petroleum, gasoline and kerosene distilled from, [114](#).

Phonograph, working of, [177-178*](#).

Phosphorescence, cause of, [341-342](#).

Phosphorus, an element, [300](#);
meaning of name, [341](#).

Photographs, process of making, [327-332*](#).

Pitch of sound, explanation of, [185-188*](#).

Plants, light and the manufacture of food in, [332-333](#);
how oxygen is supplied by, [333-335](#).

Plating of metals, [336-339*](#).

Platinum, an element, [300](#).

Poles, positive and negative, [206-207](#).

Porcelain, used as insulator, [215](#).

Positive charges of electricity, [198-200](#).

Potassium, experiment with, [304](#).

Potassium chlorate, an essential in explosives, [347](#).

Precious stones, formation of, [263-264](#).

Prism, refraction of light by, [136-140*](#);
separation of light into rainbow colors by, [162-163*](#).

Quicksilver. *See* Mercury.

Radiation of heat and light, [122*-128](#).

Radium, an element, [300](#).

Rain, [275](#);
cause of, [278-280](#).

Rainbow, making a, on wall, [162*-163](#);
how formed, [170-171](#).

Reading glasses, [144*](#);
convex lens in, [150](#).

Red color of sky at sunset, reason for, [170](#).

Reflecting telescopes, [157](#).

Reflection of light, [129-135*](#).

Refraction of light, [136-141*](#).

Resistance, electrical, [229-232](#).

Retina of eye, [151*](#), [153](#).

Reverberation of sound, [183-185](#).

Ring around moon, cause of, [131](#).

Rock candy, how made, [267](#).

Rubber, used as insulator, [215](#).

Rusting of iron, [349](#).

Safety valves on steam boilers, [347](#).

Salt, reason for, in sea, [104-105*](#);
a compound, [308](#);
elements of, [310-311](#);
formed by hydrochloric acid and zinc, [351](#);
iron, formed by lemon juice on steel, [353](#);
acids and bases turned to water and, by combining, [361-362](#).

Salt water, litmus test of, [359](#).

Samson cells, [204](#).

Scattering of light (diffusion), [158-161*](#).

Seesaw, example of a lever, [57-58*](#).

Seltzer siphon, working of, [17](#).

Ships, reason for floating, [24*-26](#).

Shock, electrical, [214](#)-215.
 Short circuits and fuses, [240](#)-245.
 Silver, an element, [300](#);
 plating of, [339](#);
 hydrochloric acid test for, [373](#).
 Silver chlorid, formation of, [327](#).
 Sinking and floating, [23](#)-28*.
 Siphon, [18](#)*.
 Sky, reason why blue, [169](#);
 why red at sunset, [170](#).
 Smoke, consistency of, [318](#)-319.
 Snow, [275](#);
 formation of, [285](#)-286.
 Snowflakes, [97](#), [286](#)*.
 Soap, how made, [357](#)-358.
 Soda water, how made, [365](#)-366.
 Sodium, experiment with, [304](#).
 Softening due to oil or water, [290](#)-292.
 Soil, litmus test of, [359](#).
 Solution, defined, [261](#);
 difference between emulsion and, [263](#);
 a mixture and not a compound, [309](#);
 chemical change helped by, [349](#).
 Sound, cause of, [174](#);
 rate of speed, [181](#)-182;
 action of, in echoes, [183](#)-185*;
 pitch of, [185](#)-188.
 Sour milk, litmus test of, [359](#);
 neutralization of, by baking soda, [362](#).
 Sourness, taste of, caused by acids, [353](#), [354](#)-355.
 Spectroscope, use of the, [172](#).
 Spectrum, the, [172](#).
 Spring water, carbon dioxid in, [366](#).
 Stability, [29](#)-34.
 Starch, iodine test for, [373](#)-374.
 Stars, twinkling of, [141](#);
 how to tell of what made, [171](#)-172.
 Static electricity, [196](#)-202*.
 Steam, reason for force exerted by, [110](#);
 geysers and volcanoes caused by, [110](#);
 real, not visible, [112](#) n.
 Steel, generally an alloy, [310](#).
 Stereopticons, lenses of, [148](#).
 Storage battery, [206](#), [207](#)*;
 action of electricity in, [339](#).
 Stoves, electric, [230](#), [232](#).
 Street car, electric motor of, [255](#)-257.
 Suction pump, [19](#)*.
 Sugar, making of, by plants, [332](#)-333;
 litmus test of, [359](#).
 Sulfur, an element, [300](#).
 Sulfuric acid, action of, on cloth, [354](#);
 litmus test of, [359](#).
 Sun, radiation of heat and light from the, [122](#)-128;
 how to tell of what made, [171](#)-172.
 Sunbeams, explanation of, [131](#).
 Sweat glands, function of, [291](#).

 Tanning, process of, [327](#).
 Telegraph apparatus, [247](#)-252*, [380](#)-381*.
 Telegraph code, [253](#).
 Telephone, working of, [253](#)-255.
 Telescopes, [156](#)*, [157](#);
 how made, [157](#);
 reflecting, [157](#).
 Temperature, finding the, by reading a thermometer, [90](#)-91.
 Thermometer, the, [89](#)*-91*.

Thermos bottle, how made, [126-127*](#).
Thunder, cause of, [200-201](#).
Tin, an element, [300](#).
Tin salt, poisonous, [353](#).
Toasters, electric, [230](#), [232](#).
Tomatoes, use of soda to neutralize acid of, [362-363](#).
Tungsten, in incandescent lamps, [231](#).
Tuning-fork experiments, [181*](#), [186-187*](#).
Twinkling of stars, cause of, [141](#).

"Up," meaning of word, [4](#).

Vacuum, defined, [11](#);
 reason for, in electric lamp, [12*](#), [317](#);
 use of, in manufacture of thermos bottles, [126-127*](#);
 impossibility of producing sound in, [176-177](#).
Valves, safety, on boilers, [347](#).
Vaseline, production of, [114](#).
Vibrations, of air, [174-181*](#);
 pitch due to rapidity of, [186](#).
Vinegar, litmus test of, [359](#);
 neutralization of lye by, [363](#).
Violin, tuning of, [187](#).
Volcanoes, cause of, [110](#);
 explosions and, [346*](#).
Volume, elasticity of, [86-87](#).

Washing soda, a common base, [356](#);
 litmus test of, [359](#).

Water, seeks its own level, [6-10](#);
 gurgling of, when poured from bottle, [13](#);
 experiment with, to show centrifugal force, [73-74](#);
 used for making thermometer, [90*-92](#);
 expansion of, when frozen, [98](#);
 evaporation of, [100-106](#);
 action of, in geysers and volcanoes, [110](#);
 absorption of light by, [169-170](#);
 as conductor of electricity, [216](#);
 use of, for generating electricity, [256-257](#);
 softening due to, [290-292](#);
 elements of, [294-297](#);
 a compound and not a mixture, [308](#);
 formed by burning fuel, [316](#);
 why fire is put out by, but not burning oil, [317](#);
 combining of carbon dioxide and, by plants, [332-333](#);
 rusting of iron by, [349](#);
 acids and bases turned to salt and, by combining, [361-362](#).
Wear, a result of friction, [53](#).
Weather, forecasting of, [282-285](#).
Weight, center of, [30-33*](#).
Wet battery, [204-205*](#).
White, a combination of all colors, [162](#).
Winds, cause of, [20-21](#).
Winter, reason for cold in, [127-128](#).
Wiring for arc lamps, [236-239](#).
Wood, poor conductor of heat, [118](#);
 carbon and hydrogen in, [315](#).

Yardstick, experiment with, to show leverage, [59*-60](#).
Yeast, action of, in bread making, [365](#).
Yellow, in flames, [318](#).
Yerkes Observatory, telescope of, [156*](#).

Zinc, in electric battery, [203-206](#);
 an element, [300](#);
 used for driving hydrogen out of acid, [301](#), [304](#).



Conservation Reader

By HAROLD W. FAIRBANKS, *Ph. D.*

Lecturer, University of California; Geography Supervisor Berkeley Public Schools

A small book bringing out in a simple and interesting manner the principles of conservation of natural resources has long been wanted, or there has been little on the subject that could be placed in the hands of pupils. It is to answer this need that Fairbanks' CONSERVATION READER has been prepared.

The book touches upon every phase of conservation, but it deals at greatest length with saving the soil, the forests, and wild life. It is one of the author's main purposes to arouse a stronger sentiment for preserving what remains of the forests as well as for extending their areas. This is because proper forestation will lessen the danger of floods and of erosion of the soil, and it will encourage the return of the wild creatures that are of so much economic importance and add so much to the joy of life.

The matter is presented in an easy narrative style that is calculated to arouse the intelligent interest of children. The text is illustrated with photographs of wild animals, trees, landscapes, and rarely beautiful birds, printed in colors. The subject is timely and the treatment is happy throughout.

CONSERVATION READER should be used as a reader or as a book for regular study in every elementary school in the country.

Cloth, vi + 216 pages.

Price \$1.40.

WORLD BOOK COMPANY

YONKERS-ON-HUDSON, NEW YORK
2126 PRAIRIE AVENUE, CHICAGO

[pg 392]



INDIAN LIFE AND INDIAN LORE

INDIAN DAYS OF THE LONG AGO

IN THE LAND OF THE HEAD-HUNTERS

TWO BOOKS FOR YOUNG PEOPLE BY

EDWARD S. CURTIS

Author of "The North American Indian"

In *Indian Days of The Long Ago* the author gives an intimate view of Indian life in the olden days, reveals the great diversity of language, dress, and habits among them, and shows how every important act of their lives was influenced by spiritual beliefs and practices.

The book tells the story of Kukúsím, an Indian lad who is eagerly awaiting the time when he shall be a warrior. It is full of mythical lore and thrilling adventures, culminating in the mountain vigil, when Kukúsím hears the spirit voices which mark the passing of his childhood. *Illustrated with photographs by the author and drawings by F. N. Wilson.*

Theodore Roosevelt once said that Mr. Curtis has caught glimpses, such as few white men ever catch, into the strange spiritual and mental life of the Indians. In *In the Land of the Head-Hunters* these glimpses are shared with his readers.

The story centers about Motana, the son of the great War Chief. The mountain vigil, the wooing and winning of Naida, the raid of Yaklus and his warriors, the rescue of the captured Naida, and the final victory, celebrated by ceremonial dances, are all described. The action is rapid and the story is told in the direct, simple style of the true epic. *Illustrated with thirty full-page photographs by the author.*

Price \$1.60 each.

WORLD BOOK COMPANY

YONKERS-ON-HUDSON, NEW YORK
2126 PRAIRIE AVENUE, CHICAGO



[pg 393]

INSECT ADVENTURES

By J. HENRI FABRE

Selected and Arranged for Young People by Louis Seymour Hasbrouck

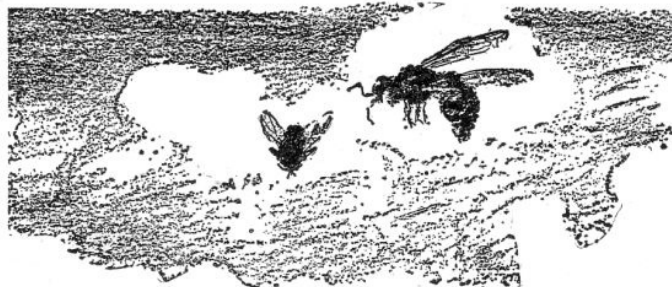

A new supplementary reader in nature study for the intermediate grades. A book containing a vast amount of information relating to insect life—the life story of the spider, the fly, the bee, the wasp, and other insects—told by one who was at once a lover of nature, a great scientist, and a most entertaining writer. Maeterlinck calls Fabre the "insects' Homer," and declares that his work is as much a classic as the famous Greek epic, and deserves to be known and studied as a classic.

This is the first time that Fabre's writings have been made available for school use, and the book will prove a delight to school children wherever they are given the chance to read it. No live boy or girl could fail to be interested in nature subjects presented by so gifted a naturalist as Fabre in the form of such absorbing adventures.

The many quaint sketches with which the book has been illustrated by Elias Goldberg complete its charm.

A useful index is included.

Cloth. 300 pages. Price \$1.48.

WORLD BOOK COMPANY

YONKERS-ON-HUDSON, NEW YORK
2126 PRAIRIE AVENUE, CHICAGO

[pg 394]

NEW-WORLD SCIENCE SERIES
Edited by John W. Ritchie

TREES, STARS *and* BIRDS

A BOOK OF OUTDOOR SCIENCE

By EDWIN LINCOLN MOSELEY
Head of the Science Department, State Normal College of Northwestern Ohio

The usefulness of nature study in the schools has been seriously limited by the lack of a suitable textbook. It is to meet this need that *Trees, Stars, and Birds* is issued. The author is one of the most successful teachers of outdoor science in this country. He believes in field excursions, and his text is designed to help teachers and pupils in the inquiries that they will make for themselves.

The text deals with three phases of outdoor science that have a perennial interest, and it will make the benefit of the author's long and successful experience available to younger teachers.

The first section deals with trees, and the discussion of maples is typical: the student is reminded that he has eaten maple sugar; there is an interesting account of its production; the fact is brought out that the sugar is really made in the leaves. The stars and planets that all should know are told about simply and clearly. The birds commonly met with are considered, and their habits of feeding and nesting are described. Pertinent questions are scattered throughout each section.

The book is illustrated with 167 photographs, 69 drawings, 9 star maps, and with 16 color plates of 58 birds, from paintings by Louis Agassiz Fuertes.

It is well adapted for use in junior high schools, yet the presentation is simple enough for pupils in the sixth grade.

Cloth. viii + 404 + xvi pages. Price \$1.80.

WORLD BOOK COMPANY

YONKERS-ON-HUDSON, NEW YORK
2126 PRAIRIE AVENUE, CHICAGO

[pg 395]

NEW-WORLD SCIENCE SERIES
Edited by John W. Ritchie

SCIENCE *for* BEGINNERS

By DELOS FALL
Professor of Chemistry, Albion College

To supply the need for a course that will give the preparatory training which any scientific study demands, *SCIENCE FOR BEGINNERS* by Professor Delos Fall was made. The aim in this text is to win the interest of pupils, to give them conceptions of nature that are fundamental, and above all to ground them in the method of science.

The subject matter has to do with the earth sciences, and principally with physics and chemistry. In the development of each topic, every advantage that the pupils' experience and interest may afford is utilized. Exercises or experiments are interspersed throughout the work, and for these only the simplest materials are required. The studies are carried to those connecting principles which permit the organization of knowledge. The book is illustrated with a number of excellent photographs and over 200 drawings of more than usual merit.

The text is adapted *for use in grades seven, eight, and nine*, or in any classes that are about to take up their first work in science. It will prove helpful to the teachers and pupils who use it directly, and its influence will continue with classes as they advance. It will thoroughly ground pupils in those ideas that are prerequisite to any right work in science.

xi + 388 pages. Price \$1.68

WORLD BOOK COMPANY

YONKERS-ON-HUDSON, NEW YORK
2126 PRAIRIE AVENUE, CHICAGO

[pg 396]

NEW-WORLD SCIENCE SERIES

Edited by JOHN W. RITCHIE

The publication of books that "apply the world's knowledge to the world's needs" is the ideal of this house and it is intended that the different volumes of this series shall express this ideal in a very concrete way.

Completed

Human Physiology. By *John W. Ritchie*, Professor of Biology, College of William and Mary. A text on physiology, hygiene, and sanitation for upper grammar or junior high schools. \$1.60.

Laboratory Manual for Human Physiology. By *Carl Hartman*, University of Texas. A manual to accompany Ritchie's Human Physiology. **Bound in paper and cloth.** 60 cents and \$1.00.

Science for Beginners. By *Delos Fall*, Albion College, Michigan. A beginning text in general science for intermediate schools and junior high schools. \$1.68.

Exercise and Review Book in Biology. By *J. G. Blaisdell*, Yonkers, N. Y., High School. A combined laboratory guide, notebook and review book for students' use. Written from the standpoint of efficiency and furnishing material for a year's work and to accompany any one of several high-school texts in general biology. **Bound in strong paper.** \$1.20.

Trees, Stars, and Birds. By *E. L. Moseley*, Ohio State Normal College, Bowling Green. A book of outdoor science for junior high schools and the upper grammar grades. \$1.80.

Personal Hygiene and Home Nursing. By *Louisa C. Lippitt*, University of Wisconsin. A practical text for use with classes of young women in vocational and industrial high schools, colleges, and normal schools. \$1.68.

Science of Plant Life. By *E. N. Transeau*, Ohio State University. A scientific and very practical text for high schools. \$1.88.

Zoölogy. By *T. D. A. Cockerell*, University of Colorado. A text for college use. \$3.60.

Experimental Organic Chemistry. By *A. P. West*, University of the Philippines. A text for college use. \$3.20.

Common Science. By *Carleton W. Washburne*, Superintendent of Schools, Winnetka, Illinois. Especially made for junior high schools. \$1.68. Also *Manual* for above, 20 cents.

Other volumes are also in preparation.

WORLD BOOK COMPANY

YONKERS-ON-HUDSON, NEW YORK
2126 PRAIRIE AVENUE, CHICAGO

[pg 397]

INDIAN LIFE AND INDIAN LORE

THE HERO OF THE LONGHOUSE

By MARY E. LAING

Illustrations from 27 paintings by David C. Lithgow

This story gives a portrayal of the noblest of Indians—Hiawatha. It follows established facts, and bares to the reader the heart of his race. It is a convincing tale.

The training of the Indian youth is shown; the career of the hero as a warrior is told; his great work for peace with the Five Tribes is described.

Besides the story, there is an account of the historical Hiawatha; also a complete Glossary giving definitions as well as pronunciations of the new Indian words. A map of the country of the Longhouse will enable the reader to follow the journeys of the Indian people.

The book is intended as a supplementary reader in schools, being adapted to the sixth grade or above. It will also be valuable in groups of the Wood-craft League, Camp-fire Girls, and Boy Scouts.

WORLD BOOK COMPANY

YONKERS-ON-HUDSON, NEW YORK
2126 PRAIRIE AVENUE, CHICAGO

[pg 398]



REGISTERED TRADE MARK

CHEMCRAFT

THE CHEMICAL OUTFIT
Makes You an Amateur Chemist!

You can perform a great many useful and practical chemical experiments, have a lot of fun, and learn the principles of chemistry, if you have a CHEMCRAFT outfit. And an outfit now will help you in chemistry later on.

Each CHEMCRAFT outfit is a complete chemical laboratory containing many harmless chemicals, all needed apparatus, and a Manual of Instruction giving accurate information on the subject. CHEMCRAFT is real chemistry. These outfits are now used by many schools and are endorsed by professors and teachers. You can choose your outfit from

Five Sizes=No. 0—75c. No. 1—\$1.50. No. 2—\$2.50. No. 3—\$5.00. No. 4—\$10.00
(West of Denver, Colo., 10% additional)

Sold by most toy stores and in any toy departments. If not obtainable near your home, any outfit will be delivered from the factory at the price listed. More complete descriptions will be sent Free to any boy or girl, or school authority, upon request.

THE PORTER CHEMICAL COMPANY

Porter Products Put Science at Your Service
HAGERSTOWN—MARYLAND

[pg 399]

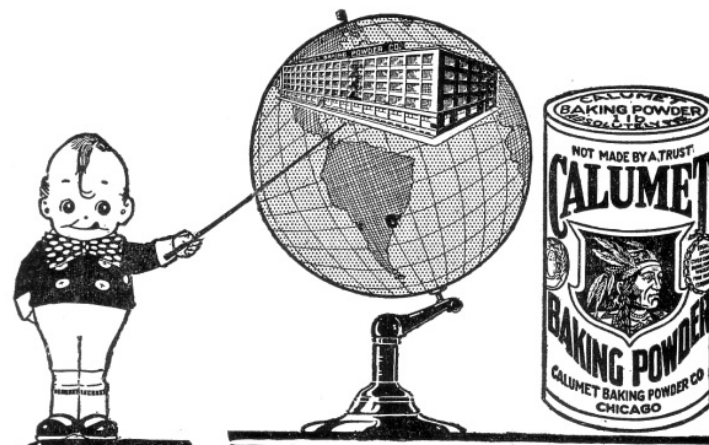

The Biggest Thing
of its kind in the World
CALUMET BAKING POWDER

The Biggest Thing of its kind in the World

CALUMET BAKING POWDER

It may be interesting to know which is the largest city in China—the largest river in Africa—but it is **more** important to know about the industrial life of your country—because when most of you go out into the world you will become active figures in the making, buying and selling of things.

The Calumet Baking Powder factories, in Chicago and East St. Louis are the largest, most modern and sanitary plants of their kind on earth. More pounds of Calumet are sold than of any other brand of baking powder.

That is because Calumet is the best purest, most dependable baking powder made; makes the finest, most wholesome, tasty pies, cakes, biscuits, doughnuts, etc.

You will find the same rule applies to everything you do in life. If you do a thing better than any one else—your services will always be in demand and you will surely be a leader in your line of work. Calumet Baking Powder is sold at a moderate price—has more than the usual leavening strength—and **never** fails.

A slip in pound can tells how to get the beautifully illustrated Calumet Cook Book.

[pg 400]

VENUS

PENCILS

The largest selling Quality pencil in the world

As soft as you wish; as hard as you please; but always smoother than you had dreamed. Any Venus Pencil you select glides over the paper with a restful freedom from friction.

17 Black Degrees, 3 Copying

- For bold, heavy lines 6B-5B-4B-3B
- For writing sketching 2B-B-HB-F-H
- For clean fine lines 2H-3H-4H-5H-6H
- For delicate, thin lines 7H-8H-9H

Plain Ends, per doz. \$1.00

Rubber Ends, per doz. 1.20

VENUS ERASERS
12 sizes

Of the same superb quality as the Venus Pencil

*Send for free sample.
At all Stationers and Stores*

American Lead Pencil
Co.
220 Fifth Ave., N. Y.
and London, Eng.



Transcriber's Notes:

page 238: changed "diagramed" to "diagrammed" (As there diagrammed, the electricity passes out...)

page 253: the Morse telegraph code is as in the original; this is not the modern International Morse code

page 383: the table of hyperlinked first letters has been added for your convenience and is not present in the original

Page 412: changed "concrete" to "concrete" (... shall express this ideal in a very concrete way.)

General: variable spelling of iodine/iodine in the original has been preserved

General: spelling of dioxid and chlorid in the original has been preserved

*** END OF THE PROJECT GUTENBERG EBOOK COMMON SCIENCE ***

Updated editions will replace the previous one—the old editions will be renamed.

Creating the works from print editions not protected by U.S. copyright law means that no one owns a United States copyright in these works, so the Foundation (and you!) can copy and distribute it in the United States without permission and without paying copyright royalties. Special rules, set forth in the General Terms of Use part of this license, apply to copying and distributing Project Gutenberg™ electronic works to protect the PROJECT GUTENBERG™ concept and trademark. Project Gutenberg is a registered trademark, and may not be used if you charge for an eBook, except by following the terms of the trademark license, including paying royalties for use of the Project Gutenberg trademark. If you do not charge anything for copies of this eBook, complying with the trademark license is very easy. You may use this eBook for nearly any purpose such as creation of derivative works, reports, performances and research. Project Gutenberg eBooks may be modified and printed and given away—you may do practically ANYTHING in the United States with eBooks not protected by U.S. copyright law. Redistribution is subject to the trademark license, especially commercial redistribution.

START: FULL LICENSE

THE FULL PROJECT GUTENBERG LICENSE

PLEASE READ THIS BEFORE YOU DISTRIBUTE OR USE THIS WORK

To protect the Project Gutenberg™ mission of promoting the free distribution of electronic works, by using or distributing this work (or any other work associated in any way with the phrase “Project Gutenberg”), you agree to comply with all the terms of the Full Project Gutenberg™ License available with this file or online at www.gutenberg.org/license.

Section 1. General Terms of Use and Redistributing Project Gutenberg™ electronic works

1.A. By reading or using any part of this Project Gutenberg™ electronic work, you indicate that you have read, understand, agree to and accept all the terms of this license and intellectual property (trademark/copyright) agreement. If you do not agree to abide by all the terms of this agreement, you must cease using and return or destroy all copies of Project Gutenberg™ electronic works in your possession. If you paid a fee for obtaining a copy of or access to a Project Gutenberg™ electronic work and you do not agree to be bound by the terms of this agreement, you may obtain a refund from the person or entity to whom you paid the fee as set forth in paragraph 1.E.8.

1.B. “Project Gutenberg” is a registered trademark. It may only be used on or associated in any way with an electronic work by people who agree to be bound by the terms of this agreement. There are a few things that you can do with most Project Gutenberg™ electronic works even without complying with the full terms of this agreement. See paragraph 1.C below. There are a lot of things you can do with Project Gutenberg™ electronic works if you follow the terms of this agreement and help preserve free future access to Project Gutenberg™ electronic works. See paragraph 1.E below.

1.C. The Project Gutenberg Literary Archive Foundation (“the Foundation” or PGLAF), owns a compilation copyright in the collection of Project Gutenberg™ electronic works. Nearly all the individual works in the collection are in the public domain in the United States. If an individual work is unprotected by copyright law in the United States and you are located in the United States, we do not claim a right to prevent you from copying, distributing, performing, displaying or creating derivative works based on the work as long as all references to Project Gutenberg are removed. Of course, we hope that you will support the Project Gutenberg™ mission of promoting free access to electronic works by freely sharing Project Gutenberg™ works in compliance with the terms of this agreement for keeping the Project Gutenberg™ name associated with the work. You can easily comply with the terms of this agreement by keeping this work in the same format with its attached full Project Gutenberg™ License when you share it without charge with others.

1.D. The copyright laws of the place where you are located also govern what you can do with this work. Copyright laws in most countries are in a constant state of change. If you are outside the United States, check the laws of your country in addition to the terms of this agreement before downloading, copying, displaying, performing, distributing or creating derivative works based on this work or any other Project Gutenberg™ work. The Foundation makes no representations concerning the copyright status of any work in any country other than the United States.

1.E. Unless you have removed all references to Project Gutenberg:

1.E.1. The following sentence, with active links to, or other immediate access to, the full Project Gutenberg™ License must appear prominently whenever any copy of a Project Gutenberg™ work (any work on which the phrase “Project Gutenberg” appears, or with which the phrase “Project Gutenberg” is associated) is accessed, displayed, performed, viewed, copied or distributed:

This eBook is for the use of anyone anywhere in the United States and most other parts of the world at no cost and with almost no restrictions whatsoever. You may copy it, give it away or re-use it under the terms of the Project Gutenberg License included with this eBook or online at www.gutenberg.org. If you are not located in the United States, you will have to check the laws of the country where you are located before using this

1.E.2. If an individual Project Gutenberg™ electronic work is derived from texts not protected by U.S. copyright law (does not contain a notice indicating that it is posted with permission of the copyright holder), the work can be copied and distributed to anyone in the United States without paying any fees or charges. If you are redistributing or providing access to a work with the phrase “Project Gutenberg” associated with or appearing on the work, you must comply either with the requirements of paragraphs 1.E.1 through 1.E.7 or obtain permission for the use of the work and the Project Gutenberg™ trademark as set forth in paragraphs 1.E.8 or 1.E.9.

1.E.3. If an individual Project Gutenberg™ electronic work is posted with the permission of the copyright holder, your use and distribution must comply with both paragraphs 1.E.1 through 1.E.7 and any additional terms imposed by the copyright holder. Additional terms will be linked to the Project Gutenberg™ License for all works posted with the permission of the copyright holder found at the beginning of this work.

1.E.4. Do not unlink or detach or remove the full Project Gutenberg™ License terms from this work, or any files containing a part of this work or any other work associated with Project Gutenberg™.

1.E.5. Do not copy, display, perform, distribute or redistribute this electronic work, or any part of this electronic work, without prominently displaying the sentence set forth in paragraph 1.E.1 with active links or immediate access to the full terms of the Project Gutenberg™ License.

1.E.6. You may convert to and distribute this work in any binary, compressed, marked up, nonproprietary or proprietary form, including any word processing or hypertext form. However, if you provide access to or distribute copies of a Project Gutenberg™ work in a format other than “Plain Vanilla ASCII” or other format used in the official version posted on the official Project Gutenberg™ website (www.gutenberg.org), you must, at no additional cost, fee or expense to the user, provide a copy, a means of exporting a copy, or a means of obtaining a copy upon request, of the work in its original “Plain Vanilla ASCII” or other form. Any alternate format must include the full Project Gutenberg™ License as specified in paragraph 1.E.1.

1.E.7. Do not charge a fee for access to, viewing, displaying, performing, copying or distributing any Project Gutenberg™ works unless you comply with paragraph 1.E.8 or 1.E.9.

1.E.8. You may charge a reasonable fee for copies of or providing access to or distributing Project Gutenberg™ electronic works provided that:

- You pay a royalty fee of 20% of the gross profits you derive from the use of Project Gutenberg™ works calculated using the method you already use to calculate your applicable taxes. The fee is owed to the owner of the Project Gutenberg™ trademark, but he has agreed to donate royalties under this paragraph to the Project Gutenberg Literary Archive Foundation. Royalty payments must be paid within 60 days following each date on which you prepare (or are legally required to prepare) your periodic tax returns. Royalty payments should be clearly marked as such and sent to the Project Gutenberg Literary Archive Foundation at the address specified in Section 4, “Information about donations to the Project Gutenberg Literary Archive Foundation.”
- You provide a full refund of any money paid by a user who notifies you in writing (or by e-mail) within 30 days of receipt that s/he does not agree to the terms of the full Project Gutenberg™ License. You must require such a user to return or destroy all copies of the works possessed in a physical medium and discontinue all use of and all access to other copies of Project Gutenberg™ works.
- You provide, in accordance with paragraph 1.F.3, a full refund of any money paid for a work or a replacement copy, if a defect in the electronic work is discovered and reported to you within 90 days of receipt of the work.
- You comply with all other terms of this agreement for free distribution of Project Gutenberg™ works.

1.E.9. If you wish to charge a fee or distribute a Project Gutenberg™ electronic work or group of works on different terms than are set forth in this agreement, you must obtain permission in writing from the Project Gutenberg Literary Archive Foundation, the manager of the Project Gutenberg™ trademark. Contact the Foundation as set forth in Section 3 below.

1.F.

1.F.1. Project Gutenberg volunteers and employees expend considerable effort to identify, do copyright research on, transcribe and proofread works not protected by U.S. copyright law in creating the Project Gutenberg™ collection. Despite these efforts, Project Gutenberg™ electronic works, and the medium on which they may be stored, may contain “Defects,” such as, but not limited to, incomplete, inaccurate or corrupt data, transcription errors, a copyright or other intellectual property infringement, a defective or damaged disk or other medium, a computer virus, or computer codes that damage or cannot be read by your equipment.

1.F.2. LIMITED WARRANTY, DISCLAIMER OF DAMAGES - Except for the “Right of Replacement or Refund” described in paragraph 1.F.3, the Project Gutenberg Literary Archive Foundation, the owner of the Project Gutenberg™ trademark, and any other party distributing a Project

Gutenberg™ electronic work under this agreement, disclaim all liability to you for damages, costs and expenses, including legal fees. YOU AGREE THAT YOU HAVE NO REMEDIES FOR NEGLIGENCE, STRICT LIABILITY, BREACH OF WARRANTY OR BREACH OF CONTRACT EXCEPT THOSE PROVIDED IN PARAGRAPH 1.F.3. YOU AGREE THAT THE FOUNDATION, THE TRADEMARK OWNER, AND ANY DISTRIBUTOR UNDER THIS AGREEMENT WILL NOT BE LIABLE TO YOU FOR ACTUAL, DIRECT, INDIRECT, CONSEQUENTIAL, PUNITIVE OR INCIDENTAL DAMAGES EVEN IF YOU GIVE NOTICE OF THE POSSIBILITY OF SUCH DAMAGE.

1.F.3. LIMITED RIGHT OF REPLACEMENT OR REFUND - If you discover a defect in this electronic work within 90 days of receiving it, you can receive a refund of the money (if any) you paid for it by sending a written explanation to the person you received the work from. If you received the work on a physical medium, you must return the medium with your written explanation. The person or entity that provided you with the defective work may elect to provide a replacement copy in lieu of a refund. If you received the work electronically, the person or entity providing it to you may choose to give you a second opportunity to receive the work electronically in lieu of a refund. If the second copy is also defective, you may demand a refund in writing without further opportunities to fix the problem.

1.F.4. Except for the limited right of replacement or refund set forth in paragraph 1.F.3, this work is provided to you 'AS-IS', WITH NO OTHER WARRANTIES OF ANY KIND, EXPRESS OR IMPLIED, INCLUDING BUT NOT LIMITED TO WARRANTIES OF MERCHANTABILITY OR FITNESS FOR ANY PURPOSE.

1.F.5. Some states do not allow disclaimers of certain implied warranties or the exclusion or limitation of certain types of damages. If any disclaimer or limitation set forth in this agreement violates the law of the state applicable to this agreement, the agreement shall be interpreted to make the maximum disclaimer or limitation permitted by the applicable state law. The invalidity or unenforceability of any provision of this agreement shall not void the remaining provisions.

1.F.6. INDEMNITY - You agree to indemnify and hold the Foundation, the trademark owner, any agent or employee of the Foundation, anyone providing copies of Project Gutenberg™ electronic works in accordance with this agreement, and any volunteers associated with the production, promotion and distribution of Project Gutenberg™ electronic works, harmless from all liability, costs and expenses, including legal fees, that arise directly or indirectly from any of the following which you do or cause to occur: (a) distribution of this or any Project Gutenberg™ work, (b) alteration, modification, or additions or deletions to any Project Gutenberg™ work, and (c) any Defect you cause.

Section 2. Information about the Mission of Project Gutenberg™

Project Gutenberg™ is synonymous with the free distribution of electronic works in formats readable by the widest variety of computers including obsolete, old, middle-aged and new computers. It exists because of the efforts of hundreds of volunteers and donations from people in all walks of life.

Volunteers and financial support to provide volunteers with the assistance they need are critical to reaching Project Gutenberg™'s goals and ensuring that the Project Gutenberg™ collection will remain freely available for generations to come. In 2001, the Project Gutenberg Literary Archive Foundation was created to provide a secure and permanent future for Project Gutenberg™ and future generations. To learn more about the Project Gutenberg Literary Archive Foundation and how your efforts and donations can help, see Sections 3 and 4 and the Foundation information page at www.gutenberg.org.

Section 3. Information about the Project Gutenberg Literary Archive Foundation

The Project Gutenberg Literary Archive Foundation is a non-profit 501(c)(3) educational corporation organized under the laws of the state of Mississippi and granted tax exempt status by the Internal Revenue Service. The Foundation's EIN or federal tax identification number is 64-6221541. Contributions to the Project Gutenberg Literary Archive Foundation are tax deductible to the full extent permitted by U.S. federal laws and your state's laws.

The Foundation's business office is located at 809 North 1500 West, Salt Lake City, UT 84116, (801) 596-1887. Email contact links and up to date contact information can be found at the Foundation's website and official page at www.gutenberg.org/contact

Section 4. Information about Donations to the Project Gutenberg Literary Archive Foundation

Project Gutenberg™ depends upon and cannot survive without widespread public support and donations to carry out its mission of increasing the number of public domain and licensed works that can be freely distributed in machine-readable form accessible by the widest array of equipment including outdated equipment. Many small donations (\$1 to \$5,000) are particularly important to maintaining tax exempt status with the IRS.

The Foundation is committed to complying with the laws regulating charities and charitable donations in all 50 states of the United States. Compliance requirements are not uniform and it takes a considerable effort, much paperwork and many fees to meet and keep up with these requirements. We do not solicit donations in locations where we have not received written confirmation of compliance. To SEND DONATIONS or determine the status of compliance for any particular state visit www.gutenberg.org/donate.

While we cannot and do not solicit contributions from states where we have not met the solicitation requirements, we know of no prohibition against accepting unsolicited donations from donors in such states who approach us with offers to donate.

International donations are gratefully accepted, but we cannot make any statements concerning tax treatment of donations received from outside the United States. U.S. laws alone swamp our small staff.

Please check the Project Gutenberg web pages for current donation methods and addresses. Donations are accepted in a number of other ways including checks, online payments and credit card donations. To donate, please visit: www.gutenberg.org/donate

Section 5. General Information About Project Gutenberg™ electronic works

Professor Michael S. Hart was the originator of the Project Gutenberg™ concept of a library of electronic works that could be freely shared with anyone. For forty years, he produced and distributed Project Gutenberg™ eBooks with only a loose network of volunteer support.

Project Gutenberg™ eBooks are often created from several printed editions, all of which are confirmed as not protected by copyright in the U.S. unless a copyright notice is included. Thus, we do not necessarily keep eBooks in compliance with any particular paper edition.

Most people start at our website which has the main PG search facility: www.gutenberg.org.

This website includes information about Project Gutenberg™, including how to make donations to the Project Gutenberg Literary Archive Foundation, how to help produce our new eBooks, and how to subscribe to our email newsletter to hear about new eBooks.