

The Project Gutenberg eBook of "I'll Leave It To You": A Light Comedy In Three Acts, by Noel Coward

This ebook is for the use of anyone anywhere in the United States and most other parts of the world at no cost and with almost no restrictions whatsoever. You may copy it, give it away or re-use it under the terms of the Project Gutenberg License included with this ebook or online at www.gutenberg.org. If you are not located in the United States, you'll have to check the laws of the country where you are located before using this eBook.

Title: "I'll Leave It To You": A Light Comedy In Three Acts

Author: Noel Coward

Release Date: January 20, 2010 [EBook #31029]

Language: English

Credits: Produced by Chuck Greif and the Online Distributed Proofreading Team at <http://www.pgdp.net> (This file was produced from images generously made available by The Internet Archive)

*** START OF THE PROJECT GUTENBERG EBOOK "I'LL LEAVE IT TO YOU": A LIGHT COMEDY
IN THREE ACTS ***

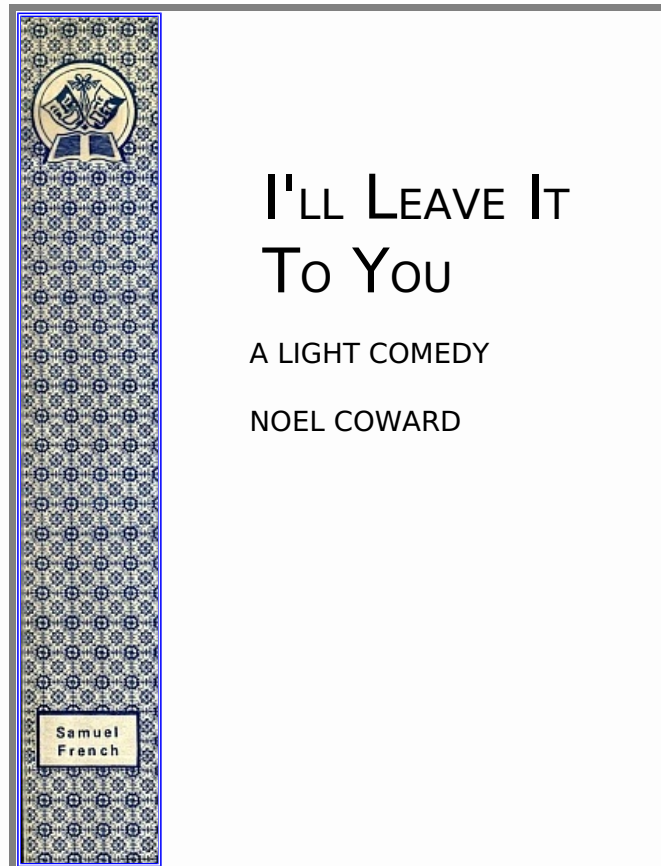

"I'LL LEAVE IT

TO YOU"

A LIGHT COMEDY IN THREE ACTS

BY
NOEL COWARD



LONDON
NEW YORK TORONTO SYDNEY HOLLYWOOD

The following text concerning the copyright and royalties was printed at the beginning of the book. It is included here for historical interest only. (note of transcriber)

Copyright 1920 by Samuel French Ltd

This play is fully protected under the copyright laws of the British Commonwealth of Nations, the United States of America, and all countries of the Berne and Universal Copyright Conventions.

All rights are strictly reserved.

It is an infringement of the copyright to give any public performance or reading of this play either in its entirety or in the form of excerpts without the prior consent of the copyright owners. No part of this publication may be transmitted, stored in a retrieval system, or reproduced in any form or by any means, electronic, mechanical, photocopying, manuscript, typescript, recording, or otherwise, without the prior permission of the Copyright owners.

SAMUEL FRENCH LTD. 26 SOUTHAMPTON STREET, STRAND, LONDON, WC2, or their authorized agents, issue licences to amateurs to give performances of this play on payment of a fee. The fee must be paid, and the licence obtained, before a performance is given.

Licences are issued subject to the understanding that it shall be made clear in all advertising matter that the audience will witness an amateur performance; and that the names of the authors of plays shall be included in all announcements and on all programmes.

The royalty fee indicated below is subject to contract and subject to variation at the sole discretion of Samuel French Ltd.

Fee for each and every
performance by amateurs Code H
in the British Isles

In territories overseas the fee quoted above may not apply. A quotation will be given upon application to the authorized agents, or direct to Samuel French Ltd.

ISBN 0 573 01199 0

To
MY MOTHER

"I'LL LEAVE IT TO YOU"

Produced on Wednesday, July 21, 1920, at the New Theatre, London, with the following Cast of Characters:—

MRS. DERMOTT		<i>Miss Kate Cutler.</i>
OLIVER	(Her Children)	<i>Mr. Douglas Jefferies.</i>
EVANGELINE		<i>Miss Muriel Pope.</i>
SYLVIA		<i>Miss Stella Jesse.</i>
BOBBIE		<i>Mr. Noël Coward.</i>
JOYCE		<i>Miss Moya Nugent.</i>
DANIEL DAVIS	(Her Brother)	<i>Mr. E. Holman Clark.</i>
MRS. CROMBIE		<i>Miss Lois Stuart.</i>
FAITH CROMBIE		<i>Miss Esmé Wynne.</i>
GRIGGS (Butler)		<i>Mr. David Clarkson.</i>

The action of the play takes place in MULBERRY MANOR, MRS. DERMOTT'S house, a few miles out of London.

Eighteen months elapse between acts one and two, and one night between acts two and three.

Act I
Act II.
Act III.
Scene Plot
Property Plot
Electric Plot

"I'LL LEAVE IT TO YOU"

A plan of the stage of the New Theatre, London, set for the play is given at the end of the book.
{*}

SCENE.—*The Hall of Mulberry Manor. All the furniture looks very comfortable. Through the window can be seen a glimpse of a snowy garden; there is a log fire. The light is a little dim, being late afternoon. Seated on the table swinging her legs is JOYCE, she is attired in a fur coat and goloshes, very little else can be seen, except a pink healthy looking young face. SYLVIA is seated on the Chesterfield R. She is twenty-one and exceedingly pretty. It is about five days before Christmas.*

JOYCE (*brightly*). My feet are simply soaking.

SYLVIA (*sewing*). Why on earth don't you go and change them? You'll catch cold.

(BOBBIE *enters* R. *He is a slim, bright-looking youth of twenty.*)

JOYCE. I don't mind if I do. (*Laughs.*) Colds are fun.

BOBBIE. She loves having a fuss made of her, beef tea—chicken—jelly with whipped cream—and fires in her bedroom, little Sybarite.

JOYCE. So do you.

BOBBIE (*comes* C.). No, I don't; whenever my various ailments confine me to my bed, I chafe—positively chafe at the terrible inactivity. I want to be up and about, shooting, riding, cricket,

football, judo, the usual run of manly sports.

SYLVIA. Knowing you for what you are—lazy, luxurious—

BOBBIE (*pained*). Please, please, please, not in front of the child. (JOYCE *kicks*). It's demoralizing for her to hear her idolized brother held up to ridicule.

JOYCE. You're not my idolized brother at all—Oliver is. (*Turning away, pouting.*)

BOBBIE (*seated R. on Chesterfield, sweetly*). If that were really so, dear, I know you have much too kind a heart to let me know it.

SYLVIA. What is the matter with you this afternoon, Bobbie—you are very up in the air about something.

(JOYCE *takes her coat off, puts on back of chair R. of table.*)

BOBBIE (*rising and sitting on club fender*). Merely another instance of the triumph of mind over matter; in this case a long and healthy walk was the matter. I went into the lobby to put on my snow boots and then—as is usually the case with me—my mind won. I thought of tea, crumpets and comfort. Oliver has gone without me, he simply bursts with health and extraordinary dullness. Personally I shall continue to be delicate and interesting.

SYLVIA (*seriously*). You may *have* to work, Bobbie.

BOBBIE. Really, Sylvia, you do say the most awful things, remember Joyce is only a school-girl, she'll be quite shocked.

JOYCE. We work jolly hard at school, anyhow.

BOBBIE. Oh, no, you don't. I've read the modern novelists, and I *know*; all you do is walk about with arms entwined, and write poems of tigerish adoration to your mistresses. It's a beautiful existence.

JOYCE. You are a silly ass. (*Picks up magazine.*)

SYLVIA. It's all very well to go on fooling Bobbie, but *really* we shall have to pull ourselves together a bit. Mother's very worried, as you know, money troubles are perfectly beastly, and she hasn't told us nearly all. I do so hate her to be upset, poor darling.

BOBBIE. What can we do? (*Sits L. end of Chesterfield. JOYCE puts down magazine and listens.*)

SYLVIA. Think of a way to make money.

BOBBIE. It's difficult now that the war is over.

SYLVIA. That's cheap wit, dear; also it's the wrong moment for it. (JOYCE *giggles.*)

BOBBIE. It's always the wrong moment for cheap wit, admitting for one moment that it was, which it wasn't.

JOYCE. Oh, do shut up, you make my head go round.

(*Enter EVANGELINE downstairs; she is tall and almost beautiful; she carries a book in her hand.*)

BOBBIE (*turning*). Oh, Vangy, do come and join us; we're on the verge of a congress.

EVANGELINE. I must read some more Maeterlinck. (*Posing.*)

BOBBIE. You mean you must let us see you reading Maeterlinck.

EVANGELINE (*goes to him, back of Chesterfield, touches his hair.*) Try not to be so irritating, Bobbie dear; just because you don't happen to appreciate good literature, it's very small and narrow to laugh at people who do.

SYLVIA. But seriously, Vangy, we are rather worried (EVANGELINE *moves*) about mother; she's been looking harassed for days.

EVANGELINE (*sitting in armchair*). What about?

SYLVIA. Money, money, money! Haven't you realized that! Uncle Daniel sent a pretty substantial cheque from South America (*all nod*) that helped things on a bit after Father's death, but that must be gone by now—and mother won't say how much father left.

JOYCE. Perhaps she doesn't know.

BOBBIE. She must know now, he's been dead nearly six months—inconsiderate old beast!

SYLVIA. Bobbie, you're not to talk about father like that. I won't have it; after all—

BOBBIE. After all what?—He was perfectly rotten to mother, and never came near her for four years before his death. Why should we be charming and reverent about him just because he's our father. When I saw him I hated him, and his treatment of mum hasn't made me like him any better, I can tell you.

EVANGELINE. But still, Bobbie, he was *our father*, and mother was fond of him—(BOBBIE. Ha!)—once, anyhow there's nothing to be gained by running him down.

SYLVIA. The point is, have we enough money to keep on as we are, or haven't we?

JOYCE (*quickly*). The only one who knows is mother, and she won't say.

SYLVIA. We haven't asked her yet; we'll make her say. Where is she?

BOBBIE. Up in her room, I think.

SYLVIA. Go and fetch her down. (*Puts sewing on form.*)

BOBBIE. What, now?

SYLVIA. Yes, *now*.

BOBBIE. Oh, no!

SYLVIA AND EVANGELINE. Yes, go along.

BOBBIE. Righto! we'll tackle her straight away.

(*Exit BOBBIE upstairs.*)

JOYCE (*goes to EVANGELINE*). Do—do you think we may have to leave this house?

SYLVIA. I don't know.

JOYCE. I should simply hate that. (*Sits on right end of form.*)

EVANGELINE. So should we all—it would be miserable.

SYLVIA. Think how awful it must be for mother.

JOYCE. I say, don't you think Oliver ought to be here—if anything's going to happen? He's the eldest.

SYLVIA. He wouldn't be any help. He cares for nothing but the inside of motors and the outside of Maisie Stuart; he's not observant enough to know her inside.

EVANGELINE. What a perfectly horrible thing to say!

SYLVIA. Well, it's absolutely true; he thinks she's everything that's good and noble, when all the time she's painfully ordinary and a bit of a cat; what fools men are.

JOYCE (*blasé*). One can't help falling in love.

(*Enter MRS. DERMOTT downstairs followed by BOBBIE; she is a pretty little woman with rather a plaintive manner.*)

MRS. DERMOTT (*as she descends*). Bobbie says you all want to talk to me! What's the matter, darlings? (*Comes C.*)

SYLVIA. That's what we want to know, mum; come on now, out with it. You've been looking worried for ever so long.

(BOBBIE *stays at foot of stairs.*)

MRS. DERMOTT. I don't know what you mean, Sylvia dear I—

SYLVIA. Now listen to me, mother; you've got something on your mind, that's obvious to any one; you're not a bit good at hiding your feelings. Surely we're all old enough to share the worry, whatever it is.

MRS. DERMOTT. (*kissing her*). Silly old darlings—it's true I have been a little worried—you see, we're ruined.

SYLVIA.
EVANGELINE. }
BOBBIE. } Mother!
JOYCE. }

(*The girls rise.*)

MRS. DERMOTT (*shaking her head sadly*). Yes, we're ruined; we haven't a penny. (*Moves to chair below table.*)

SYLVIA. Why didn't you tell us before?

MRS. DERMOTT (*sitting*). I only knew it myself this morning, I had a letter from Tibbets; he's been through all the papers and things.

EVANGELINE. Father's papers?

MRS. DERMOTT. I suppose so, dear. There wouldn't be any others, would there?

BOBBIE (*coming down*). But mother, what did he say, how did he put it?

MRS. DERMOTT. I really forget—but I know it worried me dreadfully.

(JOYCE *sits on form.*)

EVANGELINE. And we literally haven't a penny?

MRS. DERMOTT. Well, only fifteen hundred a year; it's almost as bad.

(EVANGELINE *sits in armchair.*)

JOYCE. Shall we have to give up the house?

MRS. DERMOTT. I'm afraid so, darling; you see there are taxes and rates and things. Tibbets knows all about it—he's coming down to-night.

SYLVIA. Can't Uncle Daniel do anything?

(BOBBIE *sits on table.*)

MRS. DERMOTT. He's my only hope. I cabled to South America three weeks ago. I didn't know the worst then, but I felt I wanted some one to lean on—after all, his cheque was a great help.

JOYCE. Is he very, very rich?

MRS. DERMOTT. He must be, he's a bachelor, and he has a ranch and a mine and things.

BOBBIE. Has he answered your cable?

MRS. DERMOTT. No, but of course he may have been out prospecting or broncho-breaking or something when it arrived. They live such restless lives out there—oh, no, I don't think he'll fail me, he's my only brother.

EVANGELINE. I wonder how much he *has* got.

MRS. DERMOTT. Perhaps Tibbets will know—we'll ask him.

BOBBIE. Why, is he Uncle Daniel's lawyer as well?

MRS. DERMOTT. No, dear, but you know lawyers are always clever at knowing other people's business—I shall never forget—

BOBBIE. Yes—but mother, what will happen if he *isn't* rich, and doesn't help us after all?

MRS. DERMOTT. I really don't know, darling. It's terribly upsetting, isn't it?

JOYCE. It will be *awful* having to give up the house.

MRS. DERMOTT. Well, Tibbets says we needn't for another two years. It's paid for until then or something.

SYLVIA (*sits on the Chesterfield*). Thank heaven! What a relief!

MRS. DERMOTT. But we shall have to be awfully careful. Oh, darlings (*she breaks down*), thank God I've got you. (*Weeps on BOBBIE'S knee.*)

SYLVIA. Buck up mother, it isn't as bad as all that. After all, we can work.

BOBBIE (*without enthusiasm*). Yes, we can work. (*Moving from table to R.*)

EVANGELINE. I shall write things, really artistic little fragments—

BOBBIE. We want to make money, Vangy.

MRS. DERMOTT. But, darlings, you know you can't make money unless you're Socialists and belong to Unions and things.

EVANGELINE. Well, I know *I* should make money in time. There's a great demand for really good stuff now.

SYLVIA. Do you think yours *is* really good?

EVANGELINE. I'm sure it is.

(MRS. DERMOTT *reads a magazine.*)

BOBBIE. Well, God help the bad.

EVANGELINE (*rising*). Look here, Bobbie, I'm tired of your silly jeering at me. Just stop trying to be funny. (*Moves to L.C.*)

BOBBIE (*hotly*). I realize the futility of endeavour when I see how funny others can be *without* trying (*following her.*)

EVANGELINE. Ill-bred little pip squeak!

JOYCE (*jumping up; firing*). He's not a pip squeak. Fanny Harris says he's the most good-looking boy she's ever seen.

EVANGELINE. She can't have seen many then. (*Moves to fireplace.*)

BOBBIE. Oh! Don't betray your jealousy of my looks, Evangeline. It's so degrading.

EVANGELINE. I tell you—

MRS. DERMOTT. Children, stop quarelling at once. I think it's most inconsiderate of you under the circumstances.

(BOBBIE *sits on table back to audience. There is silence for a moment.*
Enter GRIGGS from hall with a telegram.)

GRIGGS. For you, madam.

(*All show an interest.*)

MRS. DERMOTT (*taking it*). Thank you, Griggs. (*She opens it and reads it.*) There is no answer, Griggs.

(*Exit GRIGGS, R.*)

My dears!

JOYCE. What is it, mother, quick?

MRS. DERMOTT (*reading*). Arrive this afternoon—about tea time, Daniel.

SYLVIA. Uncle Daniel!

EVANGELINE. In England!

MRS. DERMOTT. I suppose so. It was handed in at Charing Cross.

BOBBIE. What luck! (*Gets off table.*)

MRS. DERMOTT. We're saved—oh, my darlings! (*She breaks down again.*)

JOYCE. He may not have any money after all.

MRS. DERMOTT. He'd never have got across so quickly if he hadn't. (*She sniffs.*) Oh, it's too, too wonderful—I have not seen him for six years.

BOBBIE. As a matter of fact it is jolly decent of him to be so prompt.

MRS. DERMOTT. Where's Oliver? He ought to be here to welcome him too.

BOBBIE (C.). Oliver has gone for a brisk walk, to keep fit he said, as if it made any difference whether he kept fit or not.

MRS. DERMOTT. It makes a lot of difference, dear. He is the athletic one of the family. (BOBBIE *is annoyed.*) I don't like the way you speak of him, Bobbie. We can't all compose songs and be brilliant. You must try and cultivate a little toleration for others, darling. (OLIVER *passes window from L.*) Oliver is a great comfort to me. Tibbets only said—

EVANGELINE (*glancing out of the window*). Here he is, anyhow. Who's going to tell him the news?

MRS. DERMOTT (*rising, goes to stairs*). Well, I've no time now, I must change my dress for Daniel. Turn on the lights, Bobbie; make everything look as cosy and festive as you can. (*On stairs.*) Run into the kitchen, Joyce dear, and tell cook to make an extra supply of hot cakes for tea. I'm sure Daniel will love them after being so long abroad and living on venison and bully beef and things. (*Ascending, then turns.*) You will all wash before tea, won't you, darlings? It's always so important to make a good first impression, and he hasn't seen any of you since you've been grown up. (*Glances in mirror.*) Oh! look at my face, I look quite happy now.

(*Exit MRS. DERMOTT upstairs.*)

SYLVIA. I think mother is rather mixing up North and South America; they don't have such awful hardships where Uncle Daniel comes from.

(*Enter OLIVER from hall; he is a thick-set, determined-looking man of twenty-five.*)

OLIVER. Hallo! (*Crossing to table, L.C.*)

JOYCE (*going to him, excitedly*). Something wonderful has happened, Oliver.

OLIVER. What is it?

JOYCE. We're ruined. I've just got to go and order extra teacakes. Isn't it all thrilling?

(*Exit JOYCE into hall.*)

OLIVER. What on earth's she talking about?

SYLVIA. It's perfectly true. We haven't any money, but Uncle Daniel's coming to-day, and we're sure he'll help us.

OLIVER (*dazed*). Haven't any money, but—

EVANGELINE (*at fire*). Mother's been rather vague as usual, but we gather that we're practically penniless, and that we shall have to give up the house after two years unless something happens.

SYLVIA. Luckily Uncle Daniel is happening—this afternoon. Mother's just had a wire from him—he's certain to be rich, mother says.

(BOBBIE *leaning against stairs*.)

OLIVER. Why?

SYLVIA. Because he's a bachelor, and has been living in South America for five years.

BOBBIE. Six years.

SYLVIA. Five years.

BOBBIE. Six years—mother said so.

SYLVIA. No, she didn't—

OLIVER. Well, it doesn't matter. How does mother know we're penniless?

BOBBIE (*coming C.*). She heard from Tibbets this morning, he's coming down to-night.

OLIVER (*sinking into chair*). By Jove, what a muddle!

(JOYCE *re-enters, crosses to chair L.C., takes coat and exits up stairs*.)

SYLVIA. It's all quite clear when you think it out.

BOBBIE (*C.*). We've all got to wash and make ourselves look clean and sweet for Uncle Daniel. Your collar's filthy; you'd better go and change it quickly. He may be here at any minute.

SYLVIA. Turn on the lights, Bobbie—and do let's hurry.

(BOBBIE *turns up the lights and goes upstairs followed by OLIVER*.
EVANGELINE *goes up slowly after them*.)

OLIVER. What a muddle! What a muddle! (*As he crosses to stairs*.)

EVANGELINE (*following him*). What a muddle! What a muddle! (*Turns on stairs*.) Shall I put on my emerald green tea gown? (*To SYLVIA*.)

SYLVIA. No, dear; it's ever so much too old for you.

EVANGELINE (*piqued*). I don't think it's at all too old for me. I shall certainly put it on.

(*She disappears upstairs. SYLVIA is left alone. Suddenly there comes a loud peal at the front door bell. SYLVIA sees some half-made crêpe-de-chine underclothes on form, takes them, hides them under cushions on window seat L. Draws curtains to window L., then L.C. as enter GRIGGS, followed by UNCLE DANIEL in an opulent-looking fur coat—he is a tall, stoutish man of about forty-five. SYLVIA shrinks back by stairs*.)

GRIGGS (*assisting him off with his coat*). If you will wait, sir, I'll tell Mrs. Dermott you are here.

DANIEL. Thank you. (*Goes round to fireplace, warms hands, turns*.)

(*GRIGGS has meanwhile taken his coat into the lobby. SYLVIA creeps cautiously from behind and goes towards stairs. DANIEL looks round and sees her. He watches her in silence for a moment, as she goes up a few stairs*.)

Excuse me—have you been stealing anything?

SYLVIA (*jumping*). Oh, Uncle Daniel—I didn't want you to see me.

DANIEL. Why not?

SYLVIA. I wanted to change my frock and do my hair.

DANIEL. It looks quite charming as it is—I suppose you are Evangeline?

SYLVIA. No I'm not, I'm Sylvia. (*Coming to him*.)

DANIEL (*below Chesterfield*). Sylvia! I didn't know there was a Sylvia.

SYLVIA (*R.C., laughing*). I was having concussion last time you were here, having cut my head open on a door scraper at school. Naturally you wouldn't remember me.

DANIEL. Oh, but I do now, you were the sole topic of conversation at lunch. How foolish of me to have let you slip my memory. Where are all the others?

SYLVIA. They're upstairs improving on the Almighty's conception of them as much as possible in your honour; I was just going to do the same when you caught me.

DANIEL. You looked extraordinarily furtive.

SYLVIA. And untidy. We've just been having a sort of family conference. It was very heating.

DANIEL. I think you might have waited for me—I'm a most important factor. What were you discussing?

SYLVIA. Oh—er—ways and means.

DANIEL. I see, it's as bad as that!

SYLVIA. But you wait until mother comes. She'll explain everything. I'll go and hurry her up. (*She goes up stairs.*)

DANIEL. Don't leave me all alone. I'm a timid creature.

SYLVIA (*turns*). After all that Broncho busting! I don't think!

(*Exit SYLVIA upstairs.*)

DANIEL. Broncho busting! What on earth does she mean? (*He walks slowly to fireplace and stands with his back to it.*)

(*Enter MRS. DERMOTT down stairs. They meet C.*)

MRS. DERMOTT. Danny! Danny! darling—

DANIEL (C.). Anne! (*He kisses her fondly.*)

MRS. DERMOTT. Oh, my dear, you have been away such a long time.

DANIEL (*he turns her round to R.*). Well, this is splendid—you do look fit! Do you know I've often longed to be home. I've imagined winter afternoons just like this—with a nice crackly fire and tea and muffins in the grate. (*Pulling her on Chesterfield.*)

MRS. DERMOTT. Oh well, they're not in the grate yet, dear, but they will be soon. I ordered a special lot because I knew you loved them.

(*He sits beside her; she is nearest the fire.*)

MRS. DERMOTT. I can never thank you enough for sending the cheque, Danny.

DANIEL. Oh, rubbish.

MRS. DERMOTT. It was the greatest help in the world.

DANIEL. I started for home the very moment I heard you were in trouble; has everything been very, very trying?

MRS. DERMOTT. Only during the last few days. You see, George hadn't been near me for four years before he died, so it wasn't such a terrible shock as it might have been. Of course, he was my husband, and it was upsetting, but still—

DANIEL. He behaved like a beast to you, and—

MRS. DERMOTT. Well, he's dead now—but don't let's discuss my affairs. Tell me about yourself; what have you been doing?

DANIEL. That can wait. Considering that the sole object of my coming to England was to help you, I think we ought to concentrate. Tell me now, has he left you very badly off?

MRS. DERMOTT. Well, Tibbets says we're ruined, but you know what Tibbets is. Such a pessimist!

DANIEL. Tibbets?

MRS. DERMOTT. Yes, our lawyer, you know.

DANIEL. Do I? How much have you got?

MRS. DERMOTT. I think Tibbets said about fifteen hundred; of course we can't keep the house and family going on that, can we?

DANIEL. Of course we can't. What do the children intend to do?

MRS. DERMOTT. Well, they don't quite know, poor darlings.

DANIEL. Poor darlings! Is Oliver at home?

MRS. DERMOTT. Yes. He's going to be a barrister or an engineer. He's very vague about it, but has been learning Pelmanism, so I know he's going to be something.

DANIEL. I see. Bobbie?

MRS. DERMOTT. Oh, Bobbie, he's so young. Of course, it's not his fault.

DANIEL. Naturally.

MRS. DERMOTT. He composes, you know—beautiful little songs,—mostly about moonlight. Evangeline writes the words. She is *very* artistic, and—

DANIEL. What does Sylvia do?

MRS. DERMOTT. Oh, she helps me.

DANIEL. In what way?

MRS. DERMOTT. Oh—er—she—well—she does the flowers, and comes calling with me, and she's *invaluable* at jumble sales, when we have them.

DANIEL. And the youngest?

MRS. DERMOTT. Joyce? Oh, she's still at school—she's going to Roedean next year to be finished.

DANIEL. Finished? Oh, I see! Well! They sound a pretty hopeless lot.

MRS. DERMOTT. Oh, Danny, how can you be so horrid? Why, they're all darlings! You can't expect them to work. They've not been brought up to it.

DANIEL. I think it's about time they started.

(*Enter* EVANGELINE *down stairs, followed by* OLIVER, BOBBIE *and* JOYCE. SYLVIA *comes last.*)

MRS. DERMOTT (*rising, back to audience*). Here they are. Children this is Uncle Daniel.

(DANIEL *rises, stands L. of Chesterfield.*)

EVANGELINE (*gracefully embracing him*). I remember you quite well.

DANIEL. Splendid. Evangeline?

EVANGELINE. Yes, Evangeline. (*Crosses to fire, down stage.*)

OLIVER (*shaking hands*). So do I. (*Moves to above* EVANGELINE.)

BOBBIE (*shaking hands*). I don't remember you a bit, but I may later when we all start reminiscencing. (*Goes L.*)

JOYCE (*kissing him*). We've been simply longing for you to come home.

DANIEL. Little Joyce— (*Joyce moves to top of table*)

SYLVIA (*kissing him*). D'you know you haven't changed a bit since I last saw you!

(DANIEL *smiles at her.*)

DANIEL. May I say that it gives me immeasurable joy to be here once more in the bosom of my family. (*Sits on Chesterfield.*)

BOBBIE. We're not really your family, but never mind.

DANIEL. I don't. But I have looked forward to this moment through the long sun-scorched nights with the great dome of the sky above me—shapes have drifted out of the surrounding blackness and beckoned to me, crying "Home, home" in depressing voices. I have heard the sand-bug calling to its mate. "Home," it said, and bit me—

(SYLVIA *sits on arm of chair, R.C.*)

MRS. DERMOTT. Silly old darling, Danny. (*Sits R. of Chesterfield.*)

JOYCE. What did you do out there, Uncle?

DANIEL. Lots of things—gold mining, ranching, auction—

BOBBIE. Auction? (*Leaning on table.*)

MRS. DERMOTT. Is it a very wonderful life, Danny?

DANIEL. Occasionally—on good days.

BOBBIE. How do you mean, good days?

DANIEL (*rather embarrassed*). Well—er—just good days.

MRS. DERMOTT. Do come and sit down, all of you; you look so terribly restless.

(*They sit, OLIVER on arm of Chesterfield, JOYCE crosses to form R., EVANGELINE on club-fender, BOBBIE chair below table, SYLVIA arm-chair.*)

DANIEL. I feel restless. It must be the home surroundings after all these years.

BOBBIE. I should love to go abroad.

DANIEL. It would make a man of you, my boy.

BOBBIE. I should simply loathe that.

DANIEL. So should I between ourselves, but still—. Oh, by the way, I—I have something rather important to say to you, you must prepare yourselves for a shock—I—I— (*He dabs his eyes with his handkerchief.*)

MRS. DERMOTT. What on earth is it, Danny?

DANIEL. I—I— (Another dab.)

SYLVIA. Oh, uncle, tell us.

DANIEL. I—er—it's this. I consulted my doctor just before I sailed.

MRS. DERMOTT. Yes?

DANIEL. He—he gave me just three years to live.

MRS. DERMOTT. Danny, what do you mean?

DANIEL (*firmly*). It's true—three years, he said.

MRS. DERMOTT. It's the most awful thing. Tell us why—what's the matter with you? (*Quickly*.)

DANIEL (*rather staggered*). The matter with me?

MRS. DERMOTT. Yes, of course, you must see a specialist at once.

DANIEL (*pulling himself together dramatically*). No specialist in the world could ever do me any good.

MRS. DERMOTT. Well, what is it? For God's sake tell us!

DANIEL (*takes big breath*). Sleeping sickness! (*Smiles broadly at MRS. DERMOTT.*)

MRS. DERMOTT. What!! (*They all move.*)

DANIEL. Yes, it's frightfully prevalent out there.

MRS. DERMOTT. Oh, Danny, I hope its not infectious.

OLIVER. Sleeping sickness! By Jove!

DANIEL. Yes, I simply daren't go to sleep without an alarm clock.

MRS. DERMOTT. Danny darling, it's all too dreadful—I can't believe it.

BOBBIE (*rising*). But, uncle, I thought sleeping sickness polished you off in one night.

DANIEL (*embarrassed*). So it does, but that one night won't happen to me for three years. The doctor says so. He knows. You see I've got it internally or something.

MRS. DERMOTT (*firmly*). You must never go back there—you shall stay with us until—until—the end—

(*She breaks down, sobs on DANIEL'S shoulder.*)

SYLVIA (*goes behind Chesterfield*). Oh, mother darling, don't cry. (*She looks at DANIEL rather angrily.*)

DANIEL (*rising*). I'm sorry I have upset you, Anne. But I have told you this to-day with a purpose in my mind. (*Moving to C.*)

OLIVER. A purpose?

DANIEL (*L. of arm-chair*). Yes, I have a few words to say to you all—words which, though they may sound a little mercenary, are in reality prompted by very deep feeling.

MRS. DERMOTT. Poor Danny.

DANIEL. Ssh! (*waves her to silence*). It may seem to all of you "banal" in the extreme to talk of money on an occasion such as this, but believe me, it's best to get it over. I came over to England this time, as I have said, with a purpose—one might almost say a double purpose. Firstly, to comfort my sister, your dear mother, in her hour of—er—tribulation. (*He pauses.*) If you would just say "yes" or "quite so" whenever I pause, it would help me enormously.

SYLVIA. All right, we will.

DANIEL. Thank you, you are a good girl. Where was I?

BOBBIE. Tribulation.

EVANGELINE. Hour of tribulation (*in his tone.*)

DANIEL. —hour of tribulation. (*He pauses.*)

SYLVIA. } Yes.
BOBBIE. } Quite so.

DANIEL. I thank you. And secondly, to feast my eyes, perhaps for the last time on earth, upon you children—also to talk to you seriously, for after all, you're my only relatives in the world.

SYLVIA. } Yes, yes.
BOBBIE. } Quite so.

DANIEL. I am as you may have guessed, a wealthy man—

EVERYONE (*eagerly*). Yes, yes! (*Movement from all.*)

DANIEL. And out there (*he nods his head descriptively*) we don't get much chance of spending our money—

BOBBIE. } Quite so.
OLIVER. } No, no!

DANIEL. And now I come to the point. At the end of three years I shall be no more.

EVANGELINE. Quite so!

OTHERS. Sh!!

(MRS. DERMOTT *sniffs.*)

DANIEL. Bear up, Anne; we must all die sometime.

MRS. DERMOTT. Yes, but not of sleeping sickness. It's so horrible. Anything else—but not sleeping sickness.

DANIEL. I believe it is very comfortable, but that is neither here nor there. What I was going to say was this, I am a firm believer in the old-fashioned laws of entail. I have no patience with this modern way of dividing up legacies between large numbers of people—

SYLVIA (*with interest*). Yes, yes?

BOBBIE (*with equal interest*). Quite so!

DANIEL. When I pass into the great beyond (MRS. DERMOTT *sniffs. He is obviously rather pleased with that remark, so he repeats it*)—pass into the great beyond, I intend to leave the whole bulk of my fortune to the one of you who has made good—

OLIVER. How do you mean "Made good"?

DANIEL. I mean make good your position in the world, justify your existence, carve for yourself a niche in the Temple of Fame— (*Turning R.*)

BOBBIE (*very quickly and brightly*). Yes, yes?

DANIEL (*turns, sharply*). That was entirely unnecessary, I didn't pause.

BOBBIE. Sorry.

(*They are all self-conscious as he addresses them.*)

DANIEL. What is the use of idling through life, frittering away your youth, I repeat, frittering away your youth, when you might be working to achieve some great and noble end? (OLIVER *embarrassed*) You, Oliver, you might in time be a great inventor, and know all about the insides of the most complicated machines. You, Evangeline (EVANGELINE *rises, poses by fireplace, one hand on mantel. JOYCE laughs—she pulls her hair*), might develop into a great poetess; your mother tells me that you already write verses about the moonlight. They all start like that, only unfortunately some of them stay like it. (*She sits again.*) You, Bobbie, you are artistic, too, you might without undue strain become a world famed composer, artist, actor. (BOBBIE *rises, moves down L., posing as actor.*) Sylvia, for you I foresee a marvellous career as a decorative designer. You already arrange flowers and jumble sales—and last, but not by any means least, little Joyce (JOYCE *hangs her head, polishes her nails*), now on the very threshold of life. What are you going to do with yourself? Sit at home and wait for a nice husband with mediocre prospects and perhaps an over-developed Adam's apple? Never, never! You too must rise and go forth—the world is calling to you. Do what you will. I can't think of a career for you at the moment, but no matter. I only want to impress upon you all the necessity of making good at something—make good, make good, make good! And the one I consider has done best for himself and the family name, to him—or her—I will bequeath every penny I possess. (*Goes up four stairs.*)

OLIVER } (*rising and all talking at once*). But look here—
EVANGELINE. } Uncle dear, of course—
BOBBIE. } How in Heaven's name are we to—
SYLVIA. } Really I don't quite see—
JOYCE. } It's going to be very difficult—

(*All looking towards DANIEL, the positions are now as follows:—DANIEL, up four stairs. MRS. DERMOTT extreme R. SYLVIA up R.C. OLIVER down R.C. EVANGELINE down C. JOYCE up L.C.. BOBBIE down L.*)

DANIEL (*holding up his hand*). Please—couldn't you possibly speak one at a time? Sylvia? (*Motions to her.*)

SYLVIA (*stepping forward*). What we want to know, uncle, is how on earth are we to start?

(*They all nod.*)

DANIEL (*smiling benignly, arms outstretched*). I'll leave it to you!

All turn to audience open-mouthed as the CURTAIN descends.

ACT II.

The SCENE is the same as Act I. Eighteen months have elapsed. All the windows are wide open. It is a glorious summer day. Alterations in the furniture are noted at the end of the play. At the table L. EVANGELINE is seated when the CURTAIN rises, typewriting slowly but firmly. There are a lot of papers strewn about. On the piano there is a sort of a pastry board to which is affixed a working model of a motor engine in miniature. JOYCE is seated at table L.C. laboriously copying out a sheet of music on to some manuscript paper.

JOYCE (*showing music*). Is it a crotchet or a quaver that has a waggle on the end of it?

EVANGELINE. I haven't the remotest idea.

JOYCE. I do think Bobbie might write them a little more distinctly, it's awfully difficult to copy.

(*JOYCE hums.*)

EVANGELINE. I don't wish to appear surly or disagreeable to my younger sister, but if you don't stop squawking I shall hurl something at you.

JOYCE. Oh, all right. (*She hums louder.*)

EVANGELINE (*after a short pause*). Joyce, you really are maddening; you know perfectly well that I have to revise and retype an entire short story which in itself is a nerve-racking job, and all you do is to burble and sing, and gabble. Can't you be quiet?

JOYCE. Why don't you go and work in your own room?

EVANGELINE. Because it would be neither comfortable or proper with three inquisitive painters there, running up and down the kitchen steps.

JOYCE. Oh, I'd forgotten.

(*JOYCE hums again.*)

EVANGELINE. But if you desire to continue your noises, may I suggest that you do your music in the summer house. There's a nice firm table there.

JOYCE. No thanks, I'm quite comfy here.

EVANGELINE. Well, I'm sorry to hear it.

(*Enter MRS. DERMOTT from hall. Goes to table and tidies papers.*)

MRS. DERMOTT. Vangy dear, I *do* think you might have made the hall look a little tidier. We shall have Mrs. Crombie and Faith here soon. It really is tiresome of Bobbie to have made me ask them, specially as Uncle Daniel's coming too. They'll be terribly in the way and we shall have to make conversation instead of listening to Uncle Daniel's thrilling stories. (*Goes to Chesterfield and tidies papers.*)

EVANGELINE. I can't think why you didn't wire and put them off yesterday.

MRS. DERMOTT. Because Bobbie would have been miserable and sulky.

EVANGELINE. He's very inconsiderate. I don't think you ought to give in to him so much, mother; it only makes him worse. What he can see in that tiresome little cat beats me.

JOYCE. She's awfully pretty.

(*MRS. DERMOTT merely takes papers from one place to another, frequently dropping some, as she is "tidying up."*)

EVANGELINE. And entirely brainless.

JOYCE. Well, we can be thankful that Mrs. Crombie isn't staying over the week-end. One day of her is bad enough.

MRS. DERMOTT (*tidying papers on form*). You mustn't talk like that, dear. After all they are our guests and Bobbie's friends, and we must be kind even if we don't like them very much. (*Picking up waste paper basket from the front of table.*) I'm only worrying because darling Daniel may be hurt at our having strangers in the house when he arrives.

JOYCE. Oh, Uncle Dan won't mind. He's probably used to face polar bears and things in his shack.

EVANGELINE. But it seems hard luck to leave raging bears on one side of the Atlantic and meet Mrs. Crombie on the other.

(JOYCE goes into screams of laughter and then chokes.)

MRS. DERMOTT (*anxiously*). Darling—do be careful. (*Drops papers and puts waste paper basket through window* L.C. Enter BOBBIE downstairs. MRS. DERMOTT continues to tidy up room.)

BOBBIE. What's the matter?

EVANGELINE. Nothing much, only your crochets and quavers have sent our little ray of sunshine into a rapid decline.

BOBBIE. Have you done it?

JOYCE (*weakly*). The top treble thing's a little wobbly, but I'll ink it over afterwards.

(MRS. DERMOTT is tidying window seat.)

BOBBIE (*kissing her hurriedly and loudly*). Thanks, you're a lamb. I'll try it now.

EVANGELINE. Oh! Bobbie, don't try it now!

BOBBIE. I shall. (*He goes to piano, then turns furiously.*) Well, really it is the *limit*. Why can't Oliver keep his rotten engine in the shed. It will scratch all the polish. (*He takes the model off piano and bangs it on to the floor.*)

MRS. DERMOTT. Oh, Bobbie, don't break that thing. Oliver's *so* proud of it. I can't think why.

BOBBIE. Well, I wish he'd go and be proud of it somewhere else. Look here, three distinct scratches.

MRS. DERMOTT. Never mind dear. Griggs will get them out with sandpaper or something.

(BOBBIE commences to play over the manuscript JOYCE has just copied. Occasionally he stops and alters something with a pencil. No one takes any notice. The dialogue goes on just the same.)

(Coming down to EVANGELINE.) If you've nearly finished, Vangy dear, do put the typewriter away. It looks so untidy.

EVANGELINE (*rather crossly, rising*). Of course I quite see that until my room's done, I shall never be able to do any work at all. (*Puts cover on typewriter, then pushes table up to back* L.)

MRS. DERMOTT. Don't be cross, darling. You know how worried I am over everything this morning. It's one long rush.

EVANGELINE (*kissing her*). Sorry dear. I quite understand, only I must have this story sent to the *Clarion* by Tuesday. If not, it won't be out until the August number.

MRS. DERMOTT. You're a dear darling, and you work terribly hard. I only hope you won't overdo it.

EVANGELINE. Oh no, these stories are only pot boilers. They just fill in the time until my next novel is ready.

BOBBIE (*suddenly*). Listen, don't you think this is a ripping change? (*He plays a few chords. He then sits back complacently.*)

MRS. DERMOTT. Perfectly lovely, darling.

EVANGELINE. It sounds very much like everything else to me.

BOBBIE. Only because you haven't got any ear. As a matter of fact they're quite good chords. I shall put them into the new tomb-stone cycle.

EVANGELINE. Don't alter many of my words, will you?

BOBBIE. Not many, but the bit about "worms gnawing the grave of my beloved" is a little too gloomy. Couldn't you make it butterflies?

(JOYCE giggles.)

EVANGELINE. Don't be silly, Bobbie! butterflies don't live in graves. Well, you can use the first two verses as they are.

BOBBIE. I will.

(He starts to play again, MRS. DERMOTT is just going towards the stairs when there comes a ring and knock at the front door.)

JOYCE (*rising*). My goodness, the Crombies—I must go and wash. I'm covered in ink. (*Going to stairs.*)

EVANGELINE (*down L. of table*). I shouldn't worry, dear, they'll be so overdressed themselves they will amply make up for any deficiencies in our appearances.

JOYCE. I think I'd better go all the same. I must do my hair.

BOBBIE. Don't dazzle them too much, dear.

(Exit JOYCE upstairs. GRIGGS crosses in corridor to open front door.)

EVANGELINE *(going to corridor)*. I'll be in presently, mother. I've left my note-book in the summer house, and I'm afraid of forgetting it.

BOBBIE *(still at piano)*. You'll meet them on the doorstep.

EVANGELINE. No, I shan't. I'm going through the drawing room window.

(Exit EVANGELINE, R.)

MRS. DERMOTT (C.). Really it's most inconsiderate of her to leave me alone like this. Bobbie darling— *(BOBBIE crosses to her, kisses her.)*

(Re-enter GRIGGS.)

GRIGGS. Mrs. Crombie, Miss Faith Crombie.

(Enter MRS. CROMBIE, and FAITH. MRS. CROMBIE is a well-preserved, rather flashy woman. FAITH is a very pretty girl, perhaps a shade too self-assured. She is all right when by herself, but when compared with the Dermott girls, there is obviously a little something lacking.)

MRS. DERMOTT *(going to her, drops quantity of papers)*. I'm so glad you were able to come, dear Mrs. Crombie. How are you, Faith dear? *(FAITH giggles, goes down to Chesterfield.)* I do hope you weren't too shaken up in the Ford, but Sylvia has taken the car up to Town to meet my brother.

(BOBBIE kicks papers up stage, then moves to bottom of table.)

MRS. CROMBIE *(up R.C.)*. Not at all, we didn't expect to be met at all. It's such a little way. Well, Bobbie, have you been writing any more successes?

BOBBIE *(laughing)*. I think I've done one or two bad enough to be good.

FAITH. Oh, mother, isn't he cynical?

MRS. DERMOTT (C.). He always talks like that. Fancy, he says his Rose song is bad. Fancy that wonderful Rose song. I'm always humming it. *(Hums few notes of "The Rosary," BOBBIE attempting to stop her.)* Well, I forget it now, but I love it.

FAITH *(down R.)*. I love it too.

BOBBIE *(down L.)*. Do you really?

FAITH. Of course. *(Moves to piano.)*

MRS. DERMOTT. Now then, shall we all go out into the garden? Oliver and Vangy are somewhere about. We always sit under the big cedar in the afternoons. It's so beautifully shady.

MRS. CROMBIE *(walking towards door with MRS. DERMOTT)*. I envy you your garden so much, Mrs. Dermott. I have about two rose bushes and a tennis net. Faith insists on that.

MRS. DERMOTT. You're lucky even to have a small garden in London.

MRS. CROMBIE *(as they go off)*. Yes, I suppose we are, you see...

(Exeunt to garden.)

FAITH. Come on, Bobbie. *(Coming C.)*

BOBBIE. No, stay here and talk to me. *(Goes to her and takes her hand.)*

FAITH. Mother will only come back and fetch me.

BOBBIE. No, she won't. They're both jawing quite happily. I have been so looking forward to today.

FAITH. So have I.

BOBBIE. I was terrified that you'd wire or something to say you couldn't come.

FAITH. Silly Bobbie.

BOBBIE. Do you realize it's a whole week since I've seen you. *(Dropping her hand.)* I've got something for you.

FAITH *(eagerly)*. What is it?

BOBBIE. A song.

FAITH *(without enthusiasm)*. Oh.

BOBBIE. Shall I play it?

FAITH *(moves to R. of table.)* Yes, do.

(Enter JOYCE downstairs.)

BOBBIE. Damn.

JOYCE. Hullo, Faith, how are you? (*They kiss.*) Come and play a single with me.

BOBBIE (*at piano*). Oh, do go away, Joyce. I'm just going to play her a song—her song.

FAITH. My song? (*Sits R. of table.*)

BOBBIE. I wrote it specially for her.

JOYCE. Aren't you lucky? Well, come out presently when you feel you're rhapsodized enough. (*Crosses to corridor.*)

BOBBIE. Oh, do shut up, Joy, and go away.

(BOBBIE *starts to play.*)

JOYCE. All right, keep calm. (*Exits and re-enters.*) Have you seen my racquet?

BOBBIE. No.

JOYCE. Oh, thanks, dear, for your kind help. Sorry I came in at the wrong moment.

(Exit JOYCE *brightly.*)

BOBBIE. Young sisters are a nuisance sometimes.

FAITH (*giggling*). They must be.

BOBBIE. Listen...

(FAITH *reads magazine and takes no notice of song. He plays and sings a short love song.*)

BOBBIE. There! Do you like it.

FAITH (*putting magazine down—ecstatically*). Oh, Bobbie, that's simply too sweet for words. It has a something about it—did you really write it for me?

BOBBIE (*ardently*). Every note.

(BOBBIE *plays a well-known and hackneyed song.*)

FAITH. Bobbie! that's wonderful! Wonderful!! It's the best you've ever done. Now I *know* you are clever.

BOBBIE (*coming C.*). Yes! but I didn't write that one.

FAITH (*goes to him*). Oh! didn't you. Well, I know you would if you had thought of it—but never mind—

FAITH. Can you play the Indian Love Lyrics—I never get tired of them!

BOBBIE. I don't want to play any more, I want to talk to you.

FAITH. What shall we talk about?

BOBBIE. I could tell you such wonderful things—but I don't know whether you would understand.

FAITH (*pouting girlishly*). That's not very polite. (*Coming down between armchair and Chesterfield.*)

BOBBIE. I mean that you wouldn't understand unless you felt like I do. Oh, I don't know how to put it—but do you?

FAITH (*coyly*). Do I what? (*Sits L. of Chesterfield.*)

BOBBIE (*by armchair—desperately*). Feel as if you could ever care—even a little bit—for me?

FAITH. I haven't tried yet.

BOBBIE. Well, will you try?

FAITH. I must ask mother.

BOBBIE (*in anguish—moving slightly C.*). Ask mother! But that's no use. Why, my mother could never make me care for someone I didn't want to, or not care for some one I did. Don't you see what I mean. If you are ever going to care for me you will have to do it on your own. Love isn't a thing to be ordered about at will. Love is wonderful—glorious, but above all, it's individual—you can't guide it. Why, you might fall in love with a taxi driver or a dope fiend—

FAITH. Mother would never allow me to *know* a dope fiend.

BOBBIE (*L. of Chesterfield—firmly*). But if you *did*, your mother's opinion wouldn't have any effect at all—not if you had it in your heart—really and truly.

FAITH. Mother's disapproval might stop me falling in love.

BOBBIE. No, it mightn't—nothing could stop it. On the contrary it would probably strengthen it; opposition always does.

FAITH (*doubtfully*). Do you think so?

BOBBIE. I'm sure of it, but anyhow, I'm going to tell you something.

(MRS. DERMOTT *appears at window* L.C. *with telegram*.)

MRS. DERMOTT. Bobbie, darling—

BOBBIE (*irritably*). What is it, mother? (*Goes up to window*.)

(FAITH *powders her nose, etc.*)

MRS. DERMOTT. I've just received the oddest telegram. We met the boy in the drive. Do listen, I can't understand it. (*She reads*.) "Come to lunch Monday and discuss Royalties—Claverton." What *does* it all mean?

BOBBIE. It's not for you, it's for Vangy. Claverton's her publisher.

MRS. DERMOTT. What on earth do they want to discuss Royalties for. It sounds *so* snobbish.

BOBBIE (*laughing*). Mother, at times you're inimitable. Royalties means money, so much per cent., you know. We've explained it heaps of times.

MRS. DERMOTT. Of course, dear, how stupid of me; but still it is very muddling, when they call things by fancy names like that. Put it on the mantelpiece and give it to Vangy when she comes in.

(*She disappears*.)

BOBBIE. Mother never will grasp the smallest technicality.

(*Coming down to fireplace, he puts the telegram on the mantelpiece*.)

FAITH. You were going to tell me something.

BOBBIE. Yes, I know something that will banish your mother's disapproval altogether....

FAITH. She hasn't disapproved yet. I only said she might.

BOBBIE. Well, she's pretty certain to want you to make a good match. I know what mothers are, they all do. I'm not a good match I know, but what she doesn't know is that I have wonderful prospects.

FAITH (*with interest*). Have you?

BOBBIE. I should never have proposed to you, otherwise.

FAITH. Well, you haven't proposed properly.

BOBBIE. I mean to when I've told you everything. Will you listen? (*Moves to R. of Chesterfield*.)

FAITH. Of course.

BOBBIE. Well, have you ever met my Uncle Daniel? (*Sits by her on Chesterfield*.)

FAITH. No.

BOBBIE. You will to-day, he's a wonderful chap. Eighteen months ago his doctor told him that he only had three years to live. (FAITH *giggles*.) And the day he came over from South America he gave us all a jolly good talking to—quite right too.

FAITH. Why?

BOBBIE. You see father had left mother badly off, and we were all drooping round doing nothing.

FAITH. Of course!

BOBBIE. Then Uncle Dan turned up and said he'd leave his whole fortune to the one of us who made good in some way or other. Of course that bucked us up no end, and look at us now—Vangy's raking in the dubs with her novel, Sylvia's on a fair way to be a big film star, Oliver has just been made assistant manager at the motor works, which is a good leg-up considering that he started as an ordinary mechanic. I'm doing jolly well out of my songs—specially "The Rose of Passion Sweet." Why they buy the beastly thing I don't know. It's the worst of the lot.

FAITH. Oh! Bobbie!

BOBBIE. Even Joyce has walked off with all the prizes at school and intends to be a great artist. You see we've all risen to the bait. Eighteen months ago it seemed providential that Uncle should only have such a short time to live, now I rather hate it, in spite of the money. He's a dear, though of course we didn't see much of him. He went back to South America soon after he'd seen us, but still he left an impression. Here we are, all working like slaves, and helping mother to keep on the house. It would have broken her heart to have given it up. There are my prospects—a huge fortune, quite soon.

FAITH. Yes, but, Bobbie, one of the others might get it.

BOBBIE (*after looking round*). Ah, but there is just one more thing to tell you. Two days before he sailed Uncle Dan took me aside and told me—in the very strictest confidence of course—that I was the one out of us all that he had his eye on; he said he'd practically made out his will in my favour already....

FAITH (*ecstatically*). Bobbie!

BOBBIE. Yes, but promise you won't breathe a word to the others; of course you understand he couldn't show favouritism openly.

FAITH. No—I see.

BOBBIE. Now that I have told you everything, Faith darling, will you—will you marry me?

FAITH. Yes, Bobbie—

BOBBIE. Oh! (*He kisses her.*)

FAITH. —if mother says I may.

BOBBIE. Oh! (*mastering slight irritation*). But don't you think she will, now?

FAITH. Yes, I think so.

BOBBIE (*sadly*). I don't believe you love me a bit.

FAITH (*filled with reproach*). Oh, Bobbie, how *can* you.

BOBBIE. Well, do you?

(MRS. CROMBIE *sees them through window L.C.*)

FAITH. Of course, silly! (*She kisses him.*)

BOBBIE (*joyfully—taking her hands*). Oh, Faith we'll have the most wonderful times in the world—just you and me together; say you're happy, say you're excited about it.

FAITH. I'm absolutely thrilled—I'm—— (BOBBIE *sees* MRS. CROMBIE. *Picks up papers on floor to hide his confusion.*)

(*Enter* MRS. CROMBIE. *They get up.*)

MRS. CROMBIE (*going L.C.*). You ought to be ashamed of yourselves, sitting indoors on a lovely day like this. (FAITH *giggles.*) Heaven knows we get little enough good air in town, without wasting it when we get into the country.

FAITH. Mother, something important has happened. (*By front of couch.*)

BOBBIE (*sincere*). Look here, Faith, you must let me tell her—it's my job, I won't shirk it.

FAITH. Don't be silly, Bobbie, go into the garden, there's a darling—I'll come out in a minute or two.

BOBBIE. But—but——

FAITH. Do be sensible.

BOBBIE. Oh, all right.... (*Goes up between Chesterfield and fireplace, and exits into garden.*)

MRS. CROMBIE. You are a little fool, Faith. Fancy flirting with that—the elder one has much more in him.

FAITH. But I don't like Oliver so much, his chin's so scrubby.

MRS. CROMBIE. Oliver is a steady man with an assured career in front of him—this one——

FAITH. Mother, we're engaged!

MRS. CROMBIE. Of course you are. That has been perfectly obvious from the moment I passed the window. Now of course we have all the trouble of getting you disengaged again. Really you are very tiresome. (*Below table.*)

FAITH. Mother, how can you be so horrid, you will *not* understand! Bobbie has ever so much better prospects than Oliver.

MRS. CROMBIE. Who said so? Bobbie?

FAITH. Yes, but it's true; his Uncle is going to leave him a huge fortune in a year's time.

MRS. CROMBIE. Which Uncle? (*Takes out cigarette from case.*)

FAITH. He's only got one—Daniel Davis. He landed in England yesterday, and is coming down here to-day. Eighteen months ago the doctor said he only had three years to live——

MRS. CROMBIE. I've been caught like that before. (*Crosses to mantelpiece for matches.*)

FAITH. Why, how do you mean?

MRS. CROMBIE. Experience has taught me one thing, and that is that in this world people *never* die when they're expected to. (*Sits on Chesterfield.*) The old man will probably live to a ripe old age, then where would you be?

FAITH. Well, anyhow Bobbie makes quite a lot out of his songs. (*Sits in armchair.*)

MRS. CROMBIE. Don't be childish, Faith. You know perfectly well I should never allow you to marry a man without a settled income—prospects never kept anyone. Besides, if any of them get the uncle's money it will be Oliver—he's the eldest. (*Lights cigarette.*)

FAITH (*in chair* L.C.). That's where you are wrong, mother. Just before he sailed back to America, he took Bobbie aside and told him in confidence that he was the one he meant to leave everything to. Of course the others mustn't know because it would be favouritism—don't you see?

MRS. CROMBIE. How much is he going to leave?

FAITH. I don't know, but it's sure to be a lot.

MRS. CROMBIE. Why?

FAITH. Well, he's a bachelor and—and he's been mining in South America.

MRS. CROMBIE. There are hundreds of bachelors in South America who are absolutely penniless—whether they mine or not.

FAITH. You are horrid, mother. (*Sniffs.*) I did feel so happy, and I wanted you to be happy too.

MRS. CROMBIE (*with slight sarcasm*). It was sweet of you, dear. I really can't work myself up to a high pitch of enthusiasm over an uncle who though apparently in the last throes of a virulent disease is well able to gallop backwards and forwards across the Atlantic gaily arranging to leave an extremely problematic fortune to an extremely scatter-brained young man.

FAITH. Bobbie isn't *scatter-brained*.

MRS. CROMBIE. The whole family is scatter-brained, and I expect the uncle's the worst of the lot—he wouldn't have been sent to South America otherwise.

FAITH. He wasn't *sent*, he went.

MRS. CROMBIE. How do you know? He probably did something disgraceful in his youth and had to leave the country. Just like my brother, your Uncle Percy. I'm certain there's a skeleton of some kind in this family—anyhow he's sure not to die when we want him to.

FAITH. The doctor said three years.

MRS. CROMBIE. Only to frighten him, that's what doctors are for. I believe they cured hundreds of cases in the army like that.

FAITH. Did they, mother.

MRS. CROMBIE. What's the matter with the man?

FAITH. I don't know.

MRS. CROMBIE. It strikes me, dear, that you had better find out a bit more before you get engaged another time.

FAITH (*tearfully*). But I don't want to be engaged another time. I want to be engaged this time. Oh, mother darling, won't you wait a little while? Just *see* the uncle. If you got him alone for a while you could find out anything—you're always so clever at that sort of thing. Oh, mother, do.

MRS. CROMBIE. I'll interview the man on one condition. That is that whatever decision I may make you promise to abide by it afterwards.

FAITH (*rises*). Yes, mother, I promise. (*Kisses her, remains below fireplace.*)

MRS. CROMBIE. Now I suppose we had better join the rest, they're being feverishly bright on the tennis lawn.

(*Enter* MRS. DERMOTT *followed by* EVANGELINE. MRS. DERMOTT *motions to* EVANGELINE *to pick up papers, who does so, placing them on table.*)

MRS. DERMOTT. Ah, there you are, Mrs. Crombie; you were bored with watching tennis too. Of course Oliver and Joyce's efforts cannot really be called tennis, but still it's an amusement for them. (*Sits in armchair.*) Have you seen my knitting anywhere, Vangy darling? I'm certain I left it here.

(FAITH *sits on form* R.)

EVANGELINE. You had it in the drawing-room before lunch. I'll go and look.

(*Exit* EVANGELINE R.)

MRS. DERMOTT. Thank you so much, dear. You know, Mrs. Crombie, I imagined that all authors

became terribly superior after a little time, but Vangy hasn't a bit—it is such a relief to me.

MRS. CROMBIE. I haven't read her book yet; I must really order it from Boots.

MRS. DERMOTT. Oh, you belong to Boots too, I did for years—there's something so fascinating in having those little ivory marker things with one's name on them, but, of course, I had to give it up when the crash came.

(Re-enter EVANGELINE with knitting.)

EVANGELINE. Here you are, mother. *(Crosses to below table.)*

MRS. DERMOTT. Thank you so much, darling. Do you know, Mrs. Crombie, I started this at the beginning of the War and I haven't finished it yet? I do hope you are not being terribly dull here, Mrs. Crombie. *(Drops ball of wool.)* I'm afraid we're awfully bad at entertaining.

MRS. CROMBIE. Not at all. You are one of those excellent hostesses who allow their guests to do as they like, it's so much more comfortable.

FAITH *(rising)*. I think I'll go and talk to Bobbie in the garden.

(Goes between Chesterfield and armchair.)

MRS. DERMOTT. Do dear, I'm sure he'd love it. *(Kisses her. FAITH giggles.)*

(Exit FAITH.)

(During following scene MRS. DERMOTT gets into complications with knitting. EVANGELINE settles herself L. with illustrated paper.)

MRS. DERMOTT. Your daughter is a dear girl, Mrs. Crombie—we are all so fond of her.

MRS. CROMBIE. It's charming of you—she simply loves being down here. Of course it is so good for her to get away from London for a little while.

MRS. DERMOTT. I only wish we could have put you up as well, but really with all the children at home, there's no room at all. I was only saying to Tibbets—my solicitor, you know—that the one thing—

MRS. CROMBIE. I understand perfectly. Anyhow, I can never leave my husband for long—men are so selfish, aren't they?

MRS. DERMOTT. Sometimes I'm afraid, but still they're rather darlings when you know how to manage them. Vangy, dear, did I tell you how many stitches I set on this sleeve?

EVANGELINE. We have many confidences, mother, but that is not one of them.

MRS. DERMOTT. Dear me, how tiresome. I'm certain I told someone.

(She gets up and rings bell above fireplace, and sits down again.)

MRS. CROMBIE. I was saying, Miss Dermott, that I must make an effort to get your book from the library.

EVANGELINE. Oh, there are one or two copies in the house—I'll lend you one.

MRS. CROMBIE. It's very kind of you.

MRS. DERMOTT. I'm sure you'll like it, I did, though Vangy tells me I didn't understand half of it. Naturally being my daughter's work it thrilled me, though where she got all her ideas from I can't think—I've always been most careful with the children's upbringing—

(Enter GRIGGS, R. and moves to above Chesterfield. He coughs.)

What is it, Griggs?

GRIGGS. You rang, madam.

MRS. DERMOTT. Did I? Now what on earth could it have been? Was it a flustered ring, Griggs, or just an ordinary calm one?

GRIGGS. Quite calm, madam.

MRS. DERMOTT *(in anguish)*. Oh, Vangy dear, what *did* I ring for?

EVANGELINE. You said something about your knitting just before.

MRS. DERMOTT. Oh, of course, yes. Griggs, do you know how many stitches I cast on for this sleeve?

GRIGGS. Forty-seven, madam.

MRS. DERMOTT. Oh, thank you so much—you're quite sure?

GRIGGS. Quite, madam, but if I might suggest it, next time an even number would be easier to remember.

MRS. DERMOTT. Yes, Griggs—remind me, won't you? You're a great help.

GRIGGS. Yes, madam.

MRS. DERMOTT. Thank you, Griggs.

(*Exit GRIGGS, R.*)

Really, I don't know what I should do without that man. I believe he's Scotch, but he's quite invaluable.

MRS. CROMBIE. So it seems.

EVANGELINE. Will Sylvia and Uncle Daniel be here in time for dinner, mother?

MRS. DERMOTT. Yes, his train arrived at Euston at eleven-thirty. They ought to be here quite soon now, unless, of course, anything has happened to the car—but still, Sylvia drives very carefully. They taught her to do lots of things like that on the films, you know—they're awfully daring—I shall never forget when they made her jump off Westminster Bridge on a horse—my sister Amy was scandalized, and I said—

MRS. CROMBIE. I can *quite* imagine it. It was very plucky of your daughter to do it, though I'm glad Faith isn't on the films—I should be worried to death.

MRS. DERMOTT. Of course I felt like that at first—but one gets hardened to anything—even my poor brother's approaching death seems less terrible now—at the time when he told us it was a fearful shock, but somehow—

MRS. CROMBIE. It must be terribly sad for you. Faith told me about it this morning. What is he suffering from?

MRS. DERMOTT. Well, to tell you the truth, we don't quite know, he will joke about it so—at first he said it was "Sleeping Sickness" and then "Creeping quickness" or pneu-somnia or something or other—one comfort, he doesn't seem to mind a bit.

MRS. CROMBIE. Perhaps the doctor diagnosed the case all wrong.

MRS. DERMOTT. Oh yes, they are careless—aren't they? Did you say "diagnosed," there now, that's the word you were trying to think of the other day for your short story, Vangy. I knew it was dia— something.

(*Enter OLIVER and JOYCE from garden—followed by FAITH and BOBBIE.*)

JOYCE. I won a sett. (*Goes to chair L. of table past.*)

OLIVER. Only because I had the sun in my eyes.

(*OLIVER puts racquet on piano.*)

JOYCE. Well, I offered to change over, but you wouldn't.

MRS. DERMOTT. What time will Sylvia and your uncle arrive?

OLIVER (*sitting on top of table*). They ought to be here any moment now, unless Sylvia's bashed up the bus.

BOBBIE (*above Chesterfield to MRS. CROMBIE, admiringly*). Isn't he technical, the way he uses all the right expressions—it gives one such a professional air to call cars "buses."

MRS. DERMOTT. It's very muddling.

(*A motor horn is heard.*)

JOYCE (*rushing to window*). Here they are.

BOBBIE. I wonder how Uncle Daniel is.

MRS. CROMBIE (*rising*). You must all be wondering that. (*Goes to table powdering.*) Faith, I shall go soon. I'm sure this man is going to be simply odious.

(*All except MRS. CROMBIE and FAITH go out to meet DANIEL. All enter together talking about their various professions. BOBBIE to fireplace; OLIVER behind table; SYLVIA up stage; JOYCE to form; EVANGELINE above fireplace; MRS. CROMBIE below table; MRS. DERMOTT C.; DANIEL L.C.; FAITH R. of table.*)

MRS. DERMOTT. Oh, Danny, darling—let me introduce you to Mrs. Crombie—my brother. And this is Faith—such a dear girl.

MRS. CROMBIE. How do you do. I've heard so much about you. Are you feeling better?

DANIEL (L.C., *jovially*). Better! Why, I never had a day's illness in my life—(*look from all*)—at least—that is until I had the illness. Yes, it's very tiresome. (*He gulps.*) A short life and a gay one, you know. (*He laughs forcedly.*)

MRS. DERMOTT. Danny, darling, I *do* hope—

DANIEL. Nonsense, dear—there is no hope—but that's a comfort to me. I always imagine hope weary after a game of blind man's buff sitting on an orange—so uncomfortable.

(MRS. CROMBIE and FAITH sit below and R. of table respectively.)

MRS. DERMOTT (*sits Chesterfield, dabbing her eyes*). Really, Danny, you are too absurd.... I'm so glad Sylvia brought you safely, I never really feel happy in my mind when she's out with the car. It's not really woman's work.

DANIEL (*sitting armchair*). As far as I can gather from what she has been telling me—filming seems to require a certain amount of unwomanly abandon!

SYLVIA (*at back of Chesterfield, laughing*). I was only telling him about that day in the middle of the village street, when I had to do three "close ups" on top of one another.

MRS. DERMOTT. It all sounds vaguely immoral to me, but I hope it's all right.

DANIEL. Define the expression "close up." What does it mean?

SYLVIA. When they bring the camera right up to your face and you have to register various emotions—fear—suspicion—joy—yearning—sorrow—(*she does them*) that's a close up.

MRS. DERMOTT. Isn't she wonderful?

MRS. CROMBIE. It really is most entertaining.

DANIEL. I think they ought to film Evangeline's novel—it's chock full of incident.

EVANGELINE (*rising, poses by mantel*). Yes, uncle, but only psychological incident—they want luridly exciting episodes for a real thriller. I mean to write a scenario one day though, it's a money-making game. (*Sits again.*)

MRS. DERMOTT. Do, dear—but please don't make the heroine jump out of attic windows or anything—it *is* so trying for Sylvia—I shall never forget Westminster Bridge and that horse.

DANIEL. It appears to be a most dashing profession.

MRS. DERMOTT (*with pride*). Oh, it is. Sylvia does the most thrilling things, I assure you. She had to rescue the Rajah from a burning house in Piccadilly only last Wednesday. It caused a great sensation.

DANIEL. So I should imagine, but why was the Rajah burning in Piccadilly?

MRS. DERMOTT. Oh, it wasn't a real Rajah of course—but he was supposed to be in the clutch of Bolsheviks—or was that another film, Sylvia?—I get so muddled—

SYLVIA. It was another film, mother, but it doesn't matter. How's your illness, Uncle Dan? You look pretty bright.

DANIEL. Oh, I expect to be quite cheery right up to the last.

MRS. DERMOTT. Oh, Danny dear, don't talk about it.

DANIEL (*with meaning*). I always think we attach too much importance to life and death.

MRS. CROMBIE (*acidly*). It depends on circumstances, of course.

DANIEL (*dramatically*). Out there where I come from—

JOYCE. Go on, uncle, do tell us.

DANIEL. I was just going to, only you interrupted me—out there on the limitless prairie, a man's life is not considered worth that much. (*He tries to snap his fingers without any success.*) There now, I can never do that properly—that much. (*He tries again.*) Damn!

BOBBIE. I can do it, uncle. (*He does it.*)

JOYCE. So can I. (*She tries.*) Oh, no I can't—Sylvia, you can. You had to when you were playing in "Spanish Passion."

SYLVIA. Never mind now, let uncle get on with his story.

DANIEL. Out there Death waits round every corner—

BOBBIE. I didn't know there were any corners on the limitless prairie.

DANIEL (*testily*). I was millions of miles away from any prairie—and, anyhow, I was only speaking metaphorically.

SYLVIA. You are irritating, Bobbie, why can't you keep quiet.

MRS. CROMBIE. There seems to be some doubt, Mr. Davis, as to what part of America you were in.

DANIEL. South America—firmly South America—in the little tiny wee, bijou village of Santa Lyta—far away from the beaten track, this lonely place lies basking in the sun. Heavens, how it basked! its natives care-free and irresponsible, dreaming idly through the long summer heat—

OLIVER. What did you do there, uncle?

DANIEL. Eh?

OLIVER. What did you do there, uncle?

DANIEL (*coming to earth*). Oh, er—lots of things—fishing—yachting.

BOBBIE. But I thought it was inland.

DANIEL. Eh?

BOBBIE. I thought it was inland.

DANIEL. So it is, but there's a lake, there's a lake! We used to sit round the camp fire in the evenings and cook the fish—yes, salmon and cucumber, and sing songs—sweet little homely ditties—your Rose song in particular, Bobbie, was a great success, I must say that—

BOBBIE. Don't perjure yourself, uncle, I know perfectly well that it's the worst thing that has ever been written.

SYLVIA. It's your most successful.

BOBBIE. Of course—I've made literally hundreds out of it—the public wallow in it—roses and passion, and wine, and eyes of blue—it makes me absolutely sick every time I hear it, but still one must write down in this world if one wants to get up.

MRS. DERMOTT. Speaking of roses, let's go out into the garden and talk—it's so stuffy in here—you can tell me some more of your adventures, Danny.

SYLVIA (*looking at him*). I'm sure he'd love to.

(*Every one gets up and drifts out on to the lawn talking. BOBBIE hangs behind for a moment with FAITH.*)

BOBBIE (*anxiously*). What did she say? (*Catching her hand as she is going out.*)

FAITH. She said she'll see—wait until to-night....

BOBBIE. Oh, Faith darling....

FAITH. Come out now, quick, or they'll miss us.

BOBBIE (*grumbling*). It doesn't matter if they do.

FAITH. Oh, yes, it does—I don't want to be talked about.

(*They go out and bang into DANIEL, who is coming in.*)

BOBBIE. Hallo, aren't you going to tell us things?

DANIEL (*comes C.*). No, not now—I must unpack—I'm feeling rather tired—I have to change—I must send a wire.... The truth of the matter is, I just want a little peace.

BOBBIE. All right, we'll leave you to it.

(*Exit BOBBIE and FAITH. DANIEL comes slowly down stage—lights a cigar and settles himself in Chesterfield.*)

(*Re-enter SYLVIA, quickly touches DANIEL on face—he jumps.*)

SYLVIA. Uncle dear, why did you slip away?

DANIEL. I explained to your brother—because I felt a little tired and wanted a rest.

SYLVIA. You're not too tired to talk to me though, are you? (*Quite quietly.*)

DANIEL (*without conviction*). No. (*Lies full length.*)

SYLVIA. Well, I'll sit down then. (*To side of Chesterfield.*)

DANIEL. Do. (*Sees she wants to sit down. He takes his legs off Chesterfield.*)

SYLVIA. So you really are better? (*Sitting L. of Chesterfield.*)

DANIEL. Of course I'm better—I feel splendid.

SYLVIA. And you *still* believe what the doctor said?

DANIEL. I always believe what every one says, I'm a most trusting person.

SYLVIA. Oh, is that how you made your money—by being trusting?

DANIEL. Certainly. I trusted other people to lose it and they did.

SYLVIA. How d'you mean—lose it?

DANIEL. Well, you see—look here, Sylvia, are you cross-examining me?

SYLVIA. Nothing could be further from my thoughts, uncle dear, I only wondered, that's all.

DANIEL. Well, don't wonder any more—it's most embarrassing—what have you been doing with yourself lately?...

SYLVIA. You know perfectly well, uncle, because you sat next to me in the car and I told you everything.

DANIEL. Well, tell me some more. Have you had any love affairs—girls always like to confide their love affairs.

SYLVIA. Only when they haven't got any—but I don't, anyhow. The only one of the family who has got it in the least badly is Bobbie; he's mad on Faith Crombie.

DANIEL. So I gathered—why, do you suppose?

SYLVIA. We can't think—she's the most irritating girl I've met for years—and her mother's hateful, too.

DANIEL. Why are they here?

SYLVIA. Oh, Bobbie wanted them asked, and mother's much too sweet to deny us anything in reason.

DANIEL. I shouldn't call Mrs. Crombie in reason—she's trying to pump me.

SYLVIA. You are rather a mysterious person you know, uncle, I should like to know lots more about you.

DANIEL. Everything about me is absolutely honourable and above board.

SYLVIA. I don't know that it is.

DANIEL. My dear Sylvia—you wound me, you grieve me—I feel deeply pained. I—

SYLVIA (*laughing*). It's no use trying to bluster out of it, uncle, you know as well as I do that it wasn't honourable of you to single me out for your money without letting the others know anything about it.

DANIEL (*quickly*). You haven't told them, have you? (*Puts his feet down.*)

SYLVIA. No—I don't break *my* word.

DANIEL. And I don't break mine, so you needn't be so sniffy.

SYLVIA. It is breaking it in a way to show favouritism.

DANIEL. I only told you in the very strictest confidence because I had faith in you—trusted you....

SYLVIA. It was very sweet of you, uncle, but I don't think you should have.

DANIEL. Well, after all, I... it's my money and surely I—

SYLVIA. You see, it's so terribly unfair to the others—of course they don't know, and I shall never breathe a word, but, uncle, I do wish you'd leave everything to one of them and not me—I shouldn't feel happy for a moment with the money—not for a single moment if I'd known all the time that I was going to get it. Rule me out of the list, there's a dear—I'm earning an awful lot now, you know, on the films and I really don't need any more—promise you'll do what I ask you?

DANIEL. I don't think you're quite in your right mind, but, still—(*smiling*) I'll see.

SYLVIA. There, I knew you'd see what I meant and be a lamb. Now tell me some of your adventures and things, and how you made the money.

DANIEL (*uncomfortably*). Really, I don't think that....

SYLVIA. It must be so glorious out there—mining and prospecting and—by the way how does one prospect?

DANIEL. How does one prospect? When one prospects one scoops up water from rivers and finds nuggets in one's hands—if one's lucky, of course.

SYLVIA. You don't seem to know very much about it, uncle.

DANIEL (*nettled*). On the contrary I know *all* about it—but you wouldn't understand if I went into technical details.

SYLVIA. I don't believe you would, either.

DANIEL (*rises and goes L.*). I think, Sylvia, that this lack of trust in your fellow-creatures is a very sinister trait in your character—you must remember that I am a much older man than you are and—

SYLVIA. I'm not a man at all.

DANIEL (*turns*). Sometimes I wish you were, then I could tell you what I really think of you.

SYLVIA (*rises and goes to him—laughing*). There, uncle, I won't tease you any more, but still it must have been a wonderful moment when you discovered you had made a fortune out of your

mine.

DANIEL. I didn't.

SYLVIA (*relentlessly*). But I thought—

DANIEL. That is—not exactly—you see it was like this....

(*Enter OLIVER from garden.*)

DANIEL (*under his breath*). Thank God! (*Sits chair below table.*)

OLIVER (*above arm-chair*). Hallo Sylvia. Mother's been looking for you—she wants you to help her pick strawberries for tea. Joyce is with her now, but she isn't much use because she eats them as fast as she picks them.

SYLVIA. I'll go now. Stay and keep Uncle Dan company, Oliver. Get him to tell you some of his South American experiences. They're awfully interesting. Bye-bye for the present, uncle.

DANIEL. Cheerio!

(*Exit SYLVIA, R.*)

I suppose you haven't such a thing as a whisky and soda about you, have you, Oliver?

OLIVER. Of course, I'll get you one.

DANIEL. I'm feeling rather exhausted.

(*OLIVER goes to side table, mixes a drink and gives it to him.*)

(*Weakly*) Thank you very much.

OLIVER (*C., fingering arm-chair*). I say, uncle—can you—er—spare me a few minutes?

DANIEL (*apprehensively*). Yes—what is it?

OLIVER (*awkwardly*). Well, it's like this—I know it's rather bad form to talk about your will—

DANIEL. Yes, it is.

OLIVER. But I feel I must. I—

DANIEL (*hurriedly*). Wait until another time, don't you worry yourself about it now. You wait until I'm dead.

OLIVER (*firmly*). No, I must get it over—I want to ask you to leave your money to one of the others and not to me at all. It was awfully decent of you to single me out and it bucked me up a lot to feel that you thought well of me, but now—well, I'm earning steadily and I really don't need a lot, in fact, it might do me harm to feel that I needn't work—also it would seem frightfully caddish to the others for me to have known all along that I was going to get it. Don't you see what I'm driving at?

DANIEL. In a way, I do, yes....

OLIVER. Well, you'll do what I ask, won't you? It's a ripping feeling being independent (*EVANGELINE passes the window*) and earning money, and I want to go on at it—(*He glances out of the window*). Here comes Vangy. Now leave it to her. Novel writing is a frightfully precarious show and she's a woman and—anyhow, will you?

DANIEL. I'll see.

(*Enter EVANGELINE.*)

EVANGELINE. Ah, there you are, Uncle Daniel—I've been looking for you—I want to have a little talk with you. (*Above Chesterfield.*)

DANIEL. My God!

EVANGELINE. What did you say?

DANIEL (*feverishly*). I said, My God!

EVANGELINE. Wasn't that a little unnecessary—but still, I expect you get used to swearing over trifles out in the backwoods.

DANIEL. I wasn't anywhere near the backwoods.

EVANGELINE. Well, wherever you were then. Do go away, Oliver, I want to talk to Uncle Daniel privately.

OLIVER. Righto—you'll remember what I said, won't you, Uncle? Cheerio.

(*Exit OLIVER, R.*)

UNCLE. Cheerio. What? Oh, yes, yes. (*after OLIVER has gone.*)

EVANGELINE (*goes to him*). Now, look here—about that will of yours—I don't feel that it's quite

fair to the others to—

(Enter MRS. CROMBIE from garden.)

MRS. CROMBIE. Oh, there you are, Mr. Davis—I've been wanting to have a little talk to you about South America. I had a brother out there, you know. (*Behind chair R.C.*)

DANIEL (*rising, jovially*). Splendid—let's talk about him for hours.

EVANGELINE (*a little annoyed*). I'll come back later, uncle. (*Moves to stairs.*)

MRS. CROMBIE. I hope I'm not interrupting a heart-to-heart talk between uncle and niece.

DANIEL. Not at all, not at all—it's a pleasure, I assure you.

EVANGELINE (*on stairs*). It doesn't matter a bit. Uncle Daniel is going to stay with us a long time, I hope.

(Exit upstairs.)

MRS. CROMBIE (*settling herself in arm-chair*). Splendid—have you such a thing as a cigarette?

DANIEL. A cigarette, yes, certainly.

MRS. CROMBIE. And a match.

DANIEL. And a match.

(*He hands her a case, she takes one, goes to mantel for matches—then he strikes a match and lights it.*)

MRS. CROMBIE (*girlishly*). Now we can be quite comfortable, can't we?

DANIEL. Quite. (*Sits on Chesterfield.*)

MRS. CROMBIE. As I was saying just now, I had a brother out in South America.

DANIEL. What part?

MRS. CROMBIE. I'm not quite sure—we don't hear from him much—he was sent out there for—for

DANIEL. I quite understand.

MRS. CROMBIE. For his health.

DANIEL. I know, they all are. It's a wonderful climate.

MRS. CROMBIE. He hasn't written for ages and ages—we were wondering if he was making money or not—it seems so far away, anything may be happening to him.

DANIEL. In all probability everything is— (*laughs to himself*).

MRS. CROMBIE. Did you have any thrilling adventures when you were making your pile?

DANIEL. Oh yes, heaps and heaps.

MRS. CROMBIE. I gather that you have a mine of some sort?

DANIEL. Yes—just near the Grand Stand.

MRS. CROMBIE. The what?

DANIEL. The Grand Slam.

MRS. CROMBIE. Slam!

DANIEL. It's the name of a mountain, you know.

MRS. CROMBIE. What a strange name! Why do they call it that?

DANIEL. I can't imagine. It's often been a source of great perplexity to me.

MRS. CROMBIE. I take it that yours is a gold mine.

DANIEL. Not so that you'd notice it.

MRS. CROMBIE. I beg your pardon?

DANIEL. Well, I mean—it's not especially a gold mine—it's a mixed mine—a little bit of everything—there's tin and silver and salt and copper and brass, and God knows what—it's most exciting wondering what we are going to find next.

MRS. CROMBIE. Yes, so I should imagine....

DANIEL. Often on weary, dark nights—filled with the cries of the jackal and the boa-constrictor.

MRS. CROMBIE. I didn't know boa-constrictors cried.

DANIEL. Only when they are upset about something. Then they can't help it. There are few

animals as highly emotional as a boa-constrictor. Anyhow, as I was saying, we lay awake in the throbbing darkness—the darkness out there always throbs—it's a most peculiar phenomenon—and wondered—Heavens, how we wondered what we should find on the following day.

MRS. CROMBIE. If you'll forgive my saying so, Mr. Davis, I fear that you are a bit of a fraud.

DANIEL. I beg your pardon?

MRS. CROMBIE. I said I thought you were a fraud.

DANIEL. Of course I am—all great men are. Look at George Washington.

MRS. CROMBIE. He wasn't a fraud.

DANIEL. We only have his word for it. Besides he knew his father had seen him cut down the cherry tree. That's why he confessed. Anyhow, why should you think I am?

MRS. CROMBIE. Because you obviously know nothing about mining, and I happen to know that there is no such thing as a mountain in South America called the Grand Slam. I was determined to find out as much as I could about you on account of my daughter.

DANIEL (*rises*). My dear madam, I assure you that there is nothing whatever between your daughter and me—my intentions are absolutely honourable. (*Moves to fireplace.*)

MRS. CROMBIE (*coldly*). I was not alluding to you, but to your nephew—your youngest nephew.

DANIEL. Oh, I see.

MRS. CROMBIE. He has been making love to her. This afternoon he proposed to her....

DANIEL. Did he, by Jove!

MRS. CROMBIE. He also spoke about a large sum of money that you intended to leave him—I'm sure you will understand my position—I naturally want my daughter to marry well—and—

DANIEL. And you mean to make quite sure of the money beforehand. I see.

MRS. CROMBIE. You put it rather crudely.

DANIEL. I think matters of this kind are better discussed crudely. One thing I will promise you, Mrs. Crombie. You shall know full particulars of my finances and everything else by the end of the day. Until then I fear that you must continue to regard me as a fraud.

MRS. CROMBIE. I hope you are not offended at my inquisitiveness, but I really—

DANIEL. My dear Mrs. Crombie, when you have knocked about the world as much as I have—one learns never to be either surprised or shocked.

MRS. CROMBIE. It is very, very hard for mothers, nowadays.

DANIEL. Yes, isn't it?

MRS. CROMBIE. The children are all so modern they become quite ungovernable....

DANIEL (*coming forward slightly*). I can only say then that my nephews and nieces are exceptions to the rule.

MRS. CROMBIE. I am so glad you are so satisfied with them.

DANIEL. I am! I never realised until to-day how absolutely splendid it was to be an uncle. How wonderfully proud I should be of the fact that they are related to me. I came home eighteen months ago expecting to find a family of irritating self-centred young people idling about—true they were idling, but I liked them in spite of it—I have returned this time to find them not only hard-workers, but successful hard-workers. There is not one of them who hasn't achieved something—even Joyce, the flapper, has set to and made good at school. I tell you I'm proud of them, so proud that I could shout it from the house tops, and may I say this, Mrs. Crombie, that if your daughter has succeeded in making Bobbie fall in love with her, she is a very fortunate young woman.

(MRS. CROMBIE *shows boredom during speech.*)

MRS. CROMBIE. Oh, is she?

DANIEL. Because he is a fine boy, so is Oliver, so are they all splendid—and she should be proud to know them.

MRS. CROMBIE. It really is very lucky that you are so contented with your lot. Personally, I'm not so ecstatic. Admitting for a moment that your nephew has such a marvellously fine character—which I doubt—he should not have made love to my daughter without being certain of his prospects.

DANIEL. I will speak to him, Mrs. Crombie.

MRS. CROMBIE. I should be very grateful if you would. (*Rises and moves up to him.*) And please understand that nothing—nothing is to be settled without my consent.

DANIEL. I quite understand that.

MRS. CROMBIE. Thank you so much—I think I'll rejoin the others in the garden now.

DANIEL. I'm sure they'd be charmed.

(Exit MRS. CROMBIE into garden. DANIEL, left alone, lights another cigarette.)

DANIEL (*feelingly*). Whew! What a woman! (*Falls on Chesterfield.*)

(EVANGELINE *peeps downstairs.*)

EVANGELINE. Has she gone?

DANIEL. Yes, thank Heaven. I say, Vangy, she is a very objectionable woman.

EVANGELINE (*coming down*). I know—we all loathe her. Now at last I can talk to you alone. (*Sits beside him.*)

DANIEL. Look here, Evangeline, I know exactly what you are going to say, and I settle it all on Griggs, if you like. He'll take it, he's a Scotsman.

EVANGELINE. How did you know?

DANIEL. Instinct, my dear, pure instinct.

EVANGELINE (*rises*). Let's talk it all over.

DANIEL (*rises and goes L.*). No, not now, I must go up to my room.

EVANGELINE. Oh, just a little talk!

DANIEL. I have some letters to write. Also I'm tired and I feel my illness coming on again. Also I must wash before tea. Also—

EVANGELINE (*laughing*). It's quite obvious that you don't want to, so I'll leave you alone. Cheerio for the present.

DANIEL. They all say that. Cheerio! I'm sure it portends something....

(*He goes off upstairs.*)

(Enter JOYCE from garden dragging FAITH after her.)

JOYCE. Now you've just got to tell the others that.

FAITH (*flustered*). But I promised Bobbie I wouldn't say a word....

JOYCE. Well, you've broken your word once, so you can do it again. Vangy! Vangy! (*She goes to window, still dragging FAITH.*) Sylvia! Oliver! Bobbie!

EVANGELINE. What on earth is the matter?

JOYCE. Faith will tell you when the others come. (*Dragging FAITH back to C.*)

FAITH. Look here, this isn't a bit fair of you. Bobbie will never forgive me....

JOYCE. I can't help Bobbie's troubles—you should have thought of that before.

(Enter SYLVIA and OLIVER from garden.)

OLIVER. What's up?

JOYCE. The moment Bobbie comes, you shall know—yell for him, Oliver....

(FAITH *attempts to escape*, SYLVIA *stops her.*)

OLIVER (*goes to window and yells*). Bobb-ie! Hurry up, we want you.

BOBBIE (*off*). All right—coming....

(*They wait in silence—JOYCE still holds firmly on to FAITH'S arm. Enter BOBBIE from garden—rather breathless. The positions are as follows:—EVANGELINE down R. SYLVIA R.C. above Chesterfield.*)

BOBBIE *a little above SYLVIA slightly on her L. FAITH C. JOYCE on FAITH'S L. OLIVER up L.*)

BOBBIE. What's the bother?

JOYCE. Now, Faith, tell them.

FAITH. I won't.

JOYCE. Very well, I will—it's most important—listen, all of you—Bobbie was flirting with Faith this afternoon, and he told her that Uncle had singled him out from us all to leave his money to....

BOBBIE. Oh, Faith, how could you. (FAITH *crosses to window L.*)

SYLVIA (*judiciously*). Is this true, Bobbie?

BOBBIE (*miserably*). Yes, but I couldn't help it....

SYLVIA. Of course you couldn't. Don't be silly—now *I'll* tell you something. Uncle said exactly the same thing to me.

EVERY ONE. What!

OLIVER. So he did to me, the dirty dog.

JOYCE. Yes, I guessed as much when Faith told me—he promised his whole fortune to me if I won prizes and things at school.

EVANGELINE. Well, I needn't tell you that he said the same to me.

BOBBIE. What's his game?

SYLVIA. Hadn't we better ask him?

OLIVER. Yes, where is he?

EVANGELINE. Upstairs writing letters, washing and being ill.

SYLVIA. Run up and fetch him, Bobbie.

BOBBIE. All right.

(*Exit upstairs two at a time.*)

OLIVER. I'd love to know what he's up to.

JOYCE. You will in a minute.

EVANGELINE. I shouldn't be too sure, if he's deceived us once, he'll probably try to do it again. I don't feel that I can trust him at all now.

JOYCE. Look here, when he comes down, what are we to say to him—Oliver'd better do it all, he's the eldest.

OLIVER (*comes down to table*). I'm hanged if I will.

SYLVIA. All right, dear, don't get crusty before the time; I expect you'll have full opportunities for that later. I'll be spokesman.

EVANGELINE. All right.

(*Re-enter DANIEL, followed by BOBBIE, wiping his hands on a towel. BOBBIE goes R.*)

DANIEL (C.). I feel a little like Lady Macbeth, but Bobbie wouldn't let me dry properly. What on earth's the matter?

EVERY ONE. [We want to know.
Look here, Uncle Daniel....
We want an explanation, Uncle Daniel.

DANIEL. You all appear to be perturbed about something.

BOBBIE. We are.

SYLVIA. Shut up, Bobbie, I'm spokesman.

DANIEL (*weakly*). Couldn't it be some one else? Sylvia's so firm with me.

SYLVIA. I think, uncle, that you occasionally need firmness. (*Coming down R. by Chesterfield.*)

DANIEL. We all do, it's a weakness of the human race—lack of stamina—I have it at the moment. Please may I sit down?

OLIVER. Yes.

DANIEL (*sinking into arm-chair*). Thank you so much. (*Weakly.*) I begin to feel sleepy. May I have perhaps—a small glass of water?

BOBBIE. All right—I'll get it. (*He goes to sideboard.*)

DANIEL. With perhaps the teeniest, weeniest little drop of whisky?

SYLVIA. This is all useless prevarication, you know—we have some very important questions to ask you.

DANIEL (*rising*). Perhaps I'd better stand up then, it's more imposing. (*He takes water from Bobbie.*) Thank you a thousand times. Cheerio!!

(*They all make a movement of annoyance.*)

SYLVIA. Now then, uncle, we've discovered that you have been deceiving us....

DANIEL (*amazed*). I—deceive you? I'm pained! I'm hurt! You've wounded me to the quick.

BOBBIE. I don't believe you've got a quick.

SYLVIA. Shut up, Bobbie!

(FAITH *is by window L.*)

SYLVIA. Yes, through the agency of Miss Crombie here.

DANIEL. Ah, Miss Crombie, I've just been chatting to your mother. (*Goes to table and puts glass on it.*)

SYLVIA (*ignoring his interruption.*) Your dastardly trick has been exposed, is it or is it not true that you took each of us aside in turn a year and a half ago and filled us up with confidential lies about your will?

DANIEL (*bravely*). It's absolutely true.

(*Move from all.*)

SYLVIA. Why did you do it?

DANIEL (*laughing with forced roguishness*). Ah!...

SYLVIA (*firmly—with emphasis on each word*). Why did you do it?

DANIEL. Do you really want to know?

EVANGELINE (*below form*). Of course we do.

DANIEL. Very well, then I'll tell you. The reason was this. You were a set of idle young bounders. (*A move from all.*) You'd never done a stroke of work in your lives—neither have I, but I didn't see why you shouldn't. There was your poor mother left comparatively hard up—you would have to have left this house which would have made her perfectly miserable, so I determined to spur you on to do something (*breaking into a smile*). I say, you must admit I've succeeded!

SYLVIA. Never mind, that—go on.

DANIEL (*still smiling*). Well, not having a penny in the world with which to help you myself—

EVERYONE. What!!!!

DANIEL. I repeat—not having a penny—

OLIVER (*below table*). Do you mean to say you haven't any money at all?

DANIEL (*cheerfully*). Not a bob! Except on the all too rare occasions when I win a bit. (*Laughing.*) If it were not for the darling little horses, I shouldn't be able to get across to England at all.

EVANGELINE. What about the mine you told us of?

(JOYCE *is R. of table.*)

DANIEL. I never told you of a mine.

EVANGELINE. Oh, uncle, you are a fibber!

DANIEL. You said I had a mine. As a matter of fact I am part owner in one. Unfortunately it was long ago proved to be absolutely worthless. But please don't worry yourselves over me. I shall be all right.

SYLVIA (R.C.). We weren't.

DANIEL (C). I didn't say you were, I said don't. I also told you, now that I come to think of it, that I had only three years to live. That was put in as a bit of local colour. I hope to live to eighty-two or even eighty-three.

BOBBIE (*above Chesterfield*). Well, all I can say is—it's the rottenest trick I ever heard.

JOYCE. Uncle, how could you? (*She sniffs.*)

BOBBIE. How dare you come here and stuff us up with promises that you can never keep. I'm jolly well fed up. I thought you were such a sport and—oh, what's the use of talking. You don't give a damn. Come away, Faith.

FAITH (*tossing her head*). Very well.

(*Exit BOBBIE and FAITH into garden.*)

EVANGELINE (*coming forward, moves between Chesterfield and arm-chair—contemptuously*). It strikes me as being a singularly pointless practical joke—I'm very disappointed in you, Uncle Daniel.

(*Exit R.*)

OLIVER (*coming in front of JOYCE*). So am I—damned disappointed. I thought you were too decent to do a thing like that.

(Exit R.)

JOYCE. I think you're horrid, it'll get all over the school now. (*She bursts into tears and exits R.*)

(SYLVIA *turns and looks at* UNCLE DANIEL.)

DANIEL. They've all had a go at me. Haven't you anything to say too, Sylvia?

SYLVIA. No, I haven't anything to say at all.

UNCLE DANIEL. Oh! (*Sits in armchair.*)

SYLVIA. You see I knew all the time. (*Goes to above him.*)

DANIEL (*incredulously*). You knew?

SYLVIA. Well, I guessed from the first and found out afterwards.

DANIEL. But how?

SYLVIA. Well, uncle darling, I knew that no one with a smile like yours could ever have a bob!

(*Kisses him, goes off laughing.* UNCLE DANIEL *settles himself in armchair, smiling.*)

CURTAIN.

ACT III.

SCENE.—*The scene is the same as the preceding acts. Alterations in the furniture are noted at the end of the play. It is seven-thirty on the morning following the events of ACT II. When the CURTAIN rises, the sun is streaming in through the open window L.C. BOBBIE can be seen standing just outside looking up apparently at an upper window.*

BOBBIE (*calling softly*). Faith! Faith!

FAITH (*heard off*). What is it?

BOBBIE. Come down and talk to me.

FAITH. Don't be silly—

BOBBIE. Please do—I've got lots to tell you.

FAITH. Oh, all right—wait a minute.

(BOBBIE *comes mooching into the hall through the window. Enter FAITH downstairs.*)

FAITH. Good morning, Mr. Dermott. (*Offers hand coldly.*)

BOBBIE (L.C.). I say—you have been quick.

FAITH (C., *coldly*). I've been up for hours—what is it you want?

BOBBIE. I've had a perfectly miserable night—I couldn't sleep a wink. I want to know if you really meant what you said last night.

FAITH. Of course I really meant it, how silly you are.

BOBBIE. I'm not silly—I thought maybe it was only the heat of the moment that made you so utterly beastly.

FAITH. If you're going to be rude I shall go away. (*She sits down in chair by Chesterfield.*)

BOBBIE. Do you really care for me so little that you can give me up at a moment's notice like that?

FAITH. You will not understand Bobbie—I had to.

BOBBIE. Why?

FAITH. Because mother made me promise.

BOBBIE (*up to her*). What did she make you promise?

FAITH. She made me promise that—that—

BOBBIE. Well?

FAITH. Well, you see I'm an only child, and mother wants me to be happy above all things and

BOBBIE. I could make you happy—wonderfully happy.

FAITH. Mother doesn't think so. You see I've always been used to having money and comforts and things.

BOBBIE. Do you imagine that I shouldn't have been able to give you all the comforts you wanted whether I had uncle's money or not? Why, in a year or so I shall be making hundreds and hundreds. I mean to be successful—nothing will stop me.

FAITH. Well, Bobbie, if you come to me again then, perhaps mother would—

BOBBIE. You mean that I'm to go on working for my happiness on the off chance of your being free to accept me? Neither you nor your mother have enough trust in me to believe that I shall make a big name for myself. Good God, it was a pretty thought of your parents to call you "Faith." I suppose if you had a couple of sisters you'd call them Hope and Charity.

FAITH. It's no use being angry and beastly about it. One must use a little common sense.

BOBBIE. It isn't a question of common sense, but common decency.

FAITH. How dare you say that. (*She pulls him round by the leg of his trousers. He brushes her hand away. She repeats this business.*) Why can't we just be friends?

BOBBIE. You know I'm much too fond of you to be just friends. Men can't switch their feelings on and off like bath-taps. If they mean a thing they mean it, and there's an end of it.

FAITH. I wish I'd never come down at all if all you mean to do is grumble at me.

BOBBIE. It's more than grumbling—it's genuine unhappiness. (*Sits on form below table.*) I quite realize now that you never really cared for me a bit, in spite of what you said; but still I want to find out why—*why* you've changed so suddenly, *why* need you have hurt me so much. If you'd written breaking it off, it would have been different, but you've been so—so unnecessarily brutal.

FAITH. It was mother's fault.

BOBBIE. Is everything you do your mother's affair? Does she count every breath you take? Why, your life simply can't be worth living!

FAITH. I wish I could make you see....

BOBBIE (*in a lower register*). I'm afraid you've made me see too much. I didn't know people could be so callous and cruel....

FAITH (*quickly*). I'm not callous and cruel.

BOBBIE. Oh yes, you are, and you've made me determine one thing, and that is that henceforth I honestly mean to cut women out of my life for ever. (*A move from FAITH.*) I know it's a hackneyed thing to say, but I mean it. I ought to have taken a lesson from other fellows' experiences, but of course I didn't.

FAITH. I think you're very silly and childish to be so bitter.

BOBBIE. Bitter! (*Laughs satirically.*) What else could I be? The one girl whom I cared for and trusted has gaily thrown me over the first moment she hears that I am not going to have as much money as she thought. I'm losing my temper now, and I'm glad of it. I shall probably repent every word I say afterwards, but that won't stop me telling you exactly what I think of you. I don't suppose you've ever been in love at all—except to the extent of having signed photographs of Owen Nares and Henry Ainley stuck all over your bedroom, but when you do, I hope you get it really badly, you deserve to be absolutely utterly wretched, as wretched as you've made me, and I hope when you do marry that you get a rotten old Scotch marmalade maker who says "Hoots!" and spills haggis all down his waistcoat.

FAITH (*bursting into tears*). Oh, Bobbie, how dare you....

(*goes to her and goes down on his knees*)

BOBBIE. Oh, Faith darling, forgive me, I didn't mean a word of it—I swear I didn't....

FAITH (*they both rise*). Whether you meant it or not I hate you. (*Pushes him away.*) You're blatant and beastly, and I never wish to see you again. (*She walks upstairs and pauses.*) I shall have breakfast in my room. (*Exit.*)

(*BOBBIE stamps out and collides with SYLVIA, who is coming in with a bunch of freshly picked flowers.*)

BOBBIE. Why can't you look where you're going?

(*He stamps out of sight.*)

SYLVIA. Nice sweet-tempered little fellow. (*Moves to above table; puts roses in bowl. Takes "Daily Mirror" from window-seat, goes down to Chesterfield and reads it.*)

(*Enter DANIEL downstairs with bag. He comes very quietly and doesn't see SYLVIA. He stumbles and SYLVIA watches him.*)

SYLVIA (*suddenly*). Excuse me! Have you been stealing any thing.

DANIEL (*putting down bag*). Damn! I didn't want any one to see me.

SYLVIA. Where were you going?

DANIEL (*coming R.C.*). To the *Green Hart*. I couldn't face another meal like dinner last night.

SYLVIA. I know it was pretty awful, but you can't go out of the house like this. Mother'd be furious.

DANIEL. One more wouldn't matter—everybody else is. (*Coming L.C.*)

SYLVIA. I'm not a bit.

DANIEL. I know, I was just going to except you; you've been charming, but really it was terrible. I can't stay. Oliver has such a lowering expression, and if Joyce gives me one more "dumb animal in pain" look, I shall scream.

SYLVIA. I can't understand why they're all being so silly—I gave them credit for more sense of humour.

DANIEL. And Bobbie—Bobbie was the worst of the lot.

SYLVIA. Well, one can forgive him a little more because of Faith.

DANIEL. Why? What about Faith?

SYLVIA (*rising, going to him*). Oh, the little beast chucked him last night, the moment she heard you weren't going to leave him a fortune.

DANIEL. Did she, by Jove!

SYLVIA (*returning R.C.*). Personally I'm delighted. I always distrusted her, and this proves what I've said all along. But that doesn't make Bobbie any better tempered about it.

DANIEL (L.C.). Poor old Bobbie, I bet he hates me.

SYLVIA. If he does he's a fool.

DANIEL. After all you can't blame him, it's only natural.

SYLVIA. He ought to be jolly grateful to you for being the means of showing her up.

DANIEL. Perhaps—but he won't be. I know what it feels like; we all go through it sometime or another. I'd love to wring that girl's neck though.

SYLVIA. You like Bobbie best of us all, don't you?

DANIEL. With the exception of you—yes. I think it's because he's the most like me. He is, you know. If he'd lived my life he'd have done exactly the same things.

SYLVIA. I wonder. (*Sits L. of Chesterfield.*)

DANIEL (*smiling*). I know. (*He sits on chair, head of table.*) He's got just the same regard for the truth, the same sublime contempt of the world, and the same amount of bombast and good opinion of himself that I started with, I only hope he'll make better use of his chances, and carve out a better career for himself.

SYLVIA. If he does, he'll owe it all to you—first for rousing him up and making him work, and secondly for getting rid of Faith for him. Had he married her, she'd have been a millstone round his neck. He doesn't realize it now, but yesterday was one of the luckiest days of his life.

DANIEL. D'you really think so?

SYLVIA. I'm sure of it.

DANIEL. That's simply splendid. You've bucked me up tremendously. I shan't mind the *Green Hart* nearly so much now. (*Rising.*)

SYLVIA (*putting him back on seat*). Uncle, you're not to go to the *Green Hart* at all, I won't have it.

DANIEL. I must. When they all sit round looking reproachfully at me, it makes me feel as if I could sink under the table.

SYLVIA (*patting him and kneeling by him*). But they won't—they'll have got over it.

DANIEL. They're all much too young to get over being made fools of as quickly as that.

SYLVIA. But, uncle—

DANIEL. It's no use—I'm firm. I won't come back until they want me. As a matter of fact I realise I've been very foolish. I shouldn't have let things go so far. Naturally they were terribly disappointed at my wanting to live till eighty-two or eighty-three, and not having any money to leave them.

SYLVIA. They're not really disappointed so much as outraged. They feel you've been laughing up your sleeve at them, as of course you have.

DANIEL. No, I haven't—you're wrong there—I haven't. I couldn't help you financially. I'd borrowed the money to come over and the cheque I'd sent before. I'd just won, so I thought that the only way to assist at all was to use mental persuasion on all of you. There's always something fascinating in the idea of having money left one. It seems such an easy way of getting it. Of course it answered better than I could have imagined in my wildest dreams.

SYLVIA. It was a little unnecessary to take each of us aside like you did and stuff us up with hope.

DANIEL. That and a bunch of keys was all I had. It was such a wonderful situation. I—never having had a penny in the wide, (*gaily*), arranging to leave you my entire fortune. (*He starts to laugh.*) You must confess it was very, very funny.

SYLVIA (*also laughing*). Yes, it was.... (*They both laugh heartily.*)

DANIEL (*still laughing*). And when I said I had sleeping sickness!...

SYLVIA (*weak with laughter*). Oh, uncle, how *could you*.

DANIEL (*wiping his eyes*). Oh dear, oh dear!

SYLVIA. Poor mother getting more mystified every minute, and bothered poor Tibbets till he doesn't know if he is on his head or his heels.

DANIEL (*rising suddenly*). But look here, they'll all be down in a minute. (*SYLVIA stands up.*) They mustn't find me here, poised for flight. I must go at once. (*Going behind Chesterfield and picking up bag.*)

SYLVIA (*L. of him*). Yes, but will you promise on your word of honour to come back the moment I send for you?

DANIEL. If you give me *your* word of honour not to send for me until everything's quite all right and everyone is perfectly amiable towards me. I couldn't bear any more rebuffs. I should burst into tears if anybody even gave me a look!

SYLVIA. Yes, I'll promise.

DANIEL. I trust you because, after all, you spotted from the first.

SYLVIA. That wasn't very difficult. I've always had a good eye for hypocrites. (*DANIEL slaps her.*) Mind you don't go any further afield than the *Green Hart!*

DANIEL. You bet I shan't!

(*Exit DANIEL through window.*)

SYLVIA (*looking out of window after him*). Bye-bye! (*Coming down stage.*) Bless his heart!

(*Enter GRIGGS from R. with breakfast dishes which he places on sideboard.*)

GRIGGS. Will you do the coffee as usual, miss?

SYLVIA. Yes, Griggs. By the way, get me a bigger bowl for those roses when you have time.

GRIGGS. Yes, miss.

(*He bangs loudly on a big gong, and exits R. Enter MRS. DERMOTT downstairs.*)

SYLVIA. Hello, mother. (*Kiss across L. banisters.*)

MRS. DERMOTT. Good morning, darling. Are there any letters?

SYLVIA. Only one for you, I think.

MRS. DERMOTT (*taking letter from table*). From Tibbets, I expect. (*Sniffs at it.*) No! From Isobel Harris. (*Sits at the head of the table.*) I do hope she doesn't want to come and stay—I couldn't bear that. (*Opens it.*) Oh no, it's only to say that Fanny's engaged to an officer in the Coldstream Guards. How splendid for her.

SYLVIA. Poor Fanny—I'm glad. (*Sits in chair on her mother's left.*)

MRS. DERMOTT. Why do you say poor Fanny, dear? I'm sure she's very fortunate. Now-a-days when nice men are so scarce. I was only saying—

SYLVIA. She didn't say he was a nice man—only that he was in the Coldstream Guards. I said poor because I can just imagine all her awful relations as bridesmaids, and her father and mother shoving her up the altar steps in their efforts to get her safely married.

MRS. DERMOTT. Isobel means well, although she's a little trying. But I've never liked Charlie—no man with such a long, droopy moustache could ever be really trusted. Besides, they're so insanitary. Sound the gong again, dear. I do wish they'd all learn to be a little more punctual.

(*SYLVIA does so, and returns to sideboard. Enter JOYCE downstairs followed by OLIVER; they are both*

obviously suffering from temper. They both kiss mother.)

JOYCE (*disagreeably, as she comes downstairs*). All right! All right!—we're coming. What's the fuss? (*Sits on form.*)

(*OLIVER crosses to Chesterfield, picks up SYLVIA's paper and reads, pacing up and down.*)

MRS. DERMOTT. There's no fuss, darling, but it's stupid to let the breakfast get cold. I've got mushrooms this morning, specially because Uncle Daniel likes them.

(*Enter BOBBIE from garden profoundly gloomy. Kisses mother.*)

BOBBIE. You could hear that beastly gong a mile off.

(*SYLVIA crosses to table with coffee and milk.*)

MRS. DERMOTT. I'm so glad, dear. It shows it's a good gong. Ring the bell, will you, Oliver? (*OLIVER does so.*) Where's Evangeline? She's generally quite an early bird.

(*Enter EVANGELINE downstairs. She is distinctly depressed.*)

EVANGELINE (*on the stairs*). Here I am, mother (*kisses MRS. DERMOTT*). (*With sarcasm.*) What a pity it is that the bath water isn't a *little* hotter. I hate tepidity in anything. (*Sits on SYLVIA's left.*)

(*BOBBIE serves bacon, sitting at the foot of the table, facing MRS. DERMOTT.*)

OLIVER. If Joyce didn't bounce in and take it all it *would* be hotter.

JOYCE. I didn't have a bath at all this morning, so there.

OLIVER. Well, you're a dirty little pig then.

MRS. DERMOTT. There's probably something wrong with the boiler. I'll see about it after breakfast.

(*Enter GRIGGS, comes below MRS. DERMOTT.*)

Oh, Griggs, just tap on Miss Crombie's door, will you, and tell her that breakfast is ready.

GRIGGS. Miss Crombie wished me to say that she is taking breakfast in her bedroom, madam. I'm sending up a tray.

MRS. DERMOTT. Quite right, Griggs. I wonder if she's feeling ill or anything. I'll go up presently. Oh, and will you find out if Mr. Davis is coming down soon?

GRIGGS. Mr. Davis is not in his room, madam.

MRS. DERMOTT. Not? How very strange—he's probably in the garden somewhere. That'll do, Griggs?

(*Exit GRIGGS, R.*)

Perhaps you'd better sound the gong again, Bobbie, he might not have heard it.

(*BOBBIE crossing in front of table goes to the gong and bangs savagely on it. Every one stops up their ears.*)

MRS. DERMOTT. You seem to have taken a dislike to that gong, darling. We must start without him, that's all. Do sit down, Oliver, you're much too big to pace backwards and forwards like that. Pour out the coffee, Sylvia dear, if it's ready.

(*OLIVER sits on EVANGELINE's left. BOBBIE sits again at the foot of the table. JOYCE drops her fork with a loud clatter—every one jumps. SYLVIA pours out coffee.*)

EVANGELINE. If you'd endeavour to cultivate a little more repose, Joyce dear, it would be an advantage.

JOYCE (*truculently*). I couldn't help it.

MRS. DERMOTT (*brightly*). Fancy—Fanny Harris is engaged.

BOBBIE (*gloomily*). What fun.

MRS. DERMOTT. It may not be fun to you, but it will be most amusing to Mrs. Harris. I do wish Daniel would come in. Where can he be?

BOBBIE. No one cares, anyhow.

MRS. DERMOTT. How can you be so horrid, Bobbie—I did think you'd have recovered from your silly temper before this. Fancy not being able to take a joke.

OLIVER. It wasn't a joke, it was true.

MRS. DERMOTT. You really are utterly absurd. Pass me the toast. I wouldn't have believed you could all have been so silly. I expect Uncle Daniel is just laughing at you.

OLIVER. Yes, that's just what he *is* doing.

MRS. DERMOTT. I really think, Oliver, that you, as the eldest, ought to set a little better example. And the marmalade—thank you. After all, considering how good he's been to us, we might allow him to have a little joke without becoming disagreeable—even if it doesn't amuse us very much. Why, I—

JOYCE. But, mother, I tell you it isn't a joke—it's the gospel truth.

MRS. DERMOTT. I've never known such a set of maddening children. Pass me the paper, will you, Sylvia? I wish to read it.

(SYLVIA *hands her newspaper from window seat and she opens it out and reads it, ignoring the family altogether. Telegraph—with extra pages inserted.*)

OLIVER (*breaking the silence*). Has any one seen my tennis racquet?

JOYCE. Bobbie had it yesterday.

BOBBIE. No, I didn't.

JOYCE. Yes, you did, you and Faith—I saw you.

OLIVER. Well, where is it now?

SYLVIA (*ruminatively*). I did see a racquet behind the summer house this morning. Would that be it?

OLIVER (*furiously*). Look here, Bobbie, if you go leaving my racquet out all night again I'll punch your head....

BOBBIE (*rising, flaring up*). I tell you I never touched your damned racquet—I've got one of my own. (*Knocks his chair over.*)

JOYCE. A jolly rotten one, though.

BOBBIE. Shut up, Joyce, and mind your own business.

EVANGELINE. Don't speak to Joyce like that, Bobbie. You ought to be ashamed of yourself.

BOBBIE. I'll speak how I like.

OLIVER (*rising*). Not while I'm here, you won't.

BOBBIE (*jeeringly*). Come on, oh strong and silent elder brother, let's be manly and knock one another about.

OLIVER. A little more of that would do you a lot of good.

BOBBIE. Well, you'd better not try it.

(OLIVER *knocks a plate on to the floor, breaking it.*)

There, that's what happens when you let elephants loose in the house. (*Picks up his chair.*)

(*During this, MRS. DERMOTT does comic business with newspaper, repeatedly dropping sheets and attempting to fold the paper.*)

MRS. DERMOTT. Oliver, if you and Bobbie can't stop quarrelling you'd better both leave the table. I can't think what's the matter with you all. Just because Uncle Daniel chose to have a little fun with you, you all behave like bears with sore heads.

(BOBBIE *and* OLIVER *re-sit and continue eating.*)

EVANGELINE. Uncle Daniel meant every word he said, mother. He hasn't got a penny in the world.

MRS. DERMOTT. Nonsense, Evangeline. How do you suppose he could get backwards and forwards to America and send me large cheques and things?

JOYCE. He wins a little from time to time by horse-racing.

MRS. DERMOTT. Rubbish. No one can ever win at horse-racing. I never did. The bookies and jockeys and people don't let you.

EVANGELINE. Mother dear, how *can* you be so obstinate. I tell you he told us all about it in here yesterday afternoon—gave us his solemn word—

MRS. DERMOTT. But only in fun, darling, only in fun—he's obviously a very rich man.

OLIVER. Hah!

MRS. DERMOTT. By the by, I wish one of you would just go into the garden and find him. The mushrooms will be ruined.

SYLVIA. He isn't in the garden at all, mother, he's gone to the *Green Hart*.

(*All look surprised.*)

MRS. DERMOTT. What do you mean, Sylvia? Why has he gone to the *Green Hart*?

SYLVIA. Because every one here had been so beastly to him.

(*They all continue breakfast hurriedly.*)

MRS. DERMOTT. You mean that he—! Oh, Sylvia! (*She bursts into tears.*)

SYLVIA. Mother darling, don't cry.... (*Rises and kisses her.*)

MRS. DERMOTT (*weeping bitterly*). Darling Danny. My only brother. And you've driven him away—after all his kindness and everything. Oh, how could you? How could you? He must be sent for at once. (*She rises and rings the bell, dropping bits of newspaper en route.*) You're wicked, wicked children, and you don't deserve any one to be kind to you ever again.

(*Enter GRIGGS, R.*)

Oh, Griggs, send the car down to the *Green Hart* at once to fetch Mr. Davis.

GRIGGS. Yes, madam.

(*Exit GRIGGS, R.*)

MRS. DERMOTT (C.). How dare you behave like you have done. I shall never, never forgive you—you're cruel and horrid and—

OLIVER. It's all very fine, mother, but he made fools of us.

MRS. DERMOTT. He didn't do anything of the sort—he only meant it kindly—going to all that trouble, too (*she weeps again*), with one foot in the grave.

BOBBIE. And the other in the *Green Hart*.

JOYCE. He's not going to die. He said he meant to live to eighty-two.

MRS. DERMOTT. Eighty-three, I think, was the age, dear, but that's just another instance of his dear unselfishness—so that you wouldn't worry over him. I know! I'm going up to my room—you've upset me for the rest of the day. Call me the very moment he comes. Oh, how could you? How could you be so unkind? Oh, just look at my nose, it's all red and shiny.

(*Exit upstairs. SYLVIA follows, standing at the foot of the stairs, looking after her. There is silence for a moment.*)

BOBBIE. That's torn it.

JOYCE. Now what are we to do?

SYLVIA (*moving down*). I know. (*At head of table.*)

OLIVER. What, then?

SYLVIA. Apologise to Uncle Dan, every one of you, for being such utter beasts.

OLIVER. Well, I'm hanged!

(*During the following speech, the others continue their breakfasts.*)

SYLVIA. So you jolly well ought to be. Who do you owe your position in the motor works to, Oliver? Uncle Dan. Who do you owe your song successes to, Bobbie? Uncle Dan. And you, Joyce, d'you think you'd have won a single thing if it hadn't been for him? Do you imagine Evangeline would have had the vim to have stuck to her novel if it hadn't been for Uncle Dan's faith in her? I know I should never have done a thing, either. And all we did it for apparently, was that he could die off conveniently and leave us his money—the moment he'd done that I suppose we should have stopped working. What charming characters! Waiting for a man to die, and then getting disagreeable because he says he doesn't want to. Do you think any one of you would stop work now for anything? Of course you wouldn't. I know *that*. Don't you see that Uncle Dan chose the one and only way of really helping us? He's worked wonders and we ought to be thankful to him until our dying day....

BOBBIE (*marmalade on toast in hand*). It's all very fine for you—he hasn't come between you and the only person you've ever loved....

SYLVIA. And that's one of the best things of all—he's been the means of showing Faith up in her true colours. Bobbie, you must realise now in your heart of hearts what a rotter she is?

BOBBIE. She wouldn't have been if it wasn't for her beastly mother. Just because you found him out before us, by a fluke, you think you can preach to us about being rude to him. Well, you'd have been just as bad under the same circumstances, if not worse. The fact of you having spotted his game doesn't make it any the less disgusting. He's behaved atrociously and you know it, making fools of us all. What do you think my friends will say? Joyce's school girls? Vangy's literary nuts?

SYLVIA (*coming down R. to below Chesterfield*). It's your own silly faults. You shouldn't have told them.

EVANGELINE (*rising*). Don't be so superior. Of course we only did in confidence. (*Going up R., followed by JOYCE.*)

SYLVIA. Well, that's not Uncle Dan's fault, he only did it for the best....

BOBBIE. Best be damned!

SYLVIA. If you can't curb your language I should think you'd better go outside.

BOBBIE (*rising, knife in hand*). I shall do exactly as I like. I'm fed up with you, Sylvia, you're as bad as he is. (*Throws knife on table.*) And if you think you can get round us by making excuses for him you're jolly well mistaken. I suppose all this is a put-up job! (*Moves to L.C.*)

SYLVIA (*R.C.*). How dare you, Bobbie! It's nothing of the sort. Only luckily I have a little discrimination, I can see the difference between good and bad, and Uncle Dan's good, good all through. He wouldn't do harm to any one or anything in the world. He did all this out of genuine kindness. He couldn't help us in any other way, so he made us work, hoping it would improve us. And I should think he'd go back to America sick and wretched inside with disappointment having discovered that we, his only relatives, have only liked him and been nice to him because of his money—waiting for him to die like beastly treacherous ghouls.

(*EVANGELINE attempts to speak.*)

That's what you are, ghouls! (*Turning on EVANGELINE.*) And selfish pigs, and if you don't apologise to him I shall never speak to any of you again.

OLIVER. Hah! (*Throws down serviette and exits R.*)

SYLVIA. Oh, you're very dignified walking out like that without saying anything. I hate you! I hate you all! Poor Uncle Daniel—it's rotten. (*She bursts out crying, and subsides on Chesterfield.*)

(*Towards the end of her speech, the rest have risen and walked out with their heads in the air, R. BOBBIE kicks violently at paper on floor and goes upstairs. There is a moment's pause, then enter DANIEL from garden.*)

DANIEL (*coming C.*). I left the car down the drive, hoping to make a sweet lovable entrance with perhaps a few rose leaves on my coat. Where is everybody?

SYLVIA (*sniffing on Chesterfield*). It's no use, they're still being beastly. Mother sent for you. She's frightfully upset at your going to the *Green Hart*.

DANIEL. If they're keeping it up, I think I'd better go back. (*Moving towards entrance.*)

SYLVIA (*rising*). No, you're not to do anything of the sort, you're to stay here. (*Firmly.*) They can be as disagreeable as they like, we'll go about together; you can come to the studio with me tomorrow morning.

DANIEL (*up to her*). You, Sylvia, are what is described as a sympathetic character. You've been very nice to me all along. Can I leave you anything?

SYLVIA. Don't joke about it, uncle, it's all so horrid.

DANIEL. If I don't joke I shall burst into storms of passionate sobbing. (*Moves down C.*)

SYLVIA. That would be rather awful. Here comes mother....

(*Enter MRS. DERMOTT downstairs.*)

MRS. DERMOTT. Danny darling, why were you so silly as to take any notice of the children? They're unkind and heartless, and I ordered the mushrooms specially for you this morning. Sit down and have them now. They'll be quite hot still. (*She pushes him into chair.*) Sylvia, get them, if you please. I can't think why they're all behaving like this, I shall never forgive them, Danny dear. You won't let them upset you, will you?

(*She kisses him. MRS. DERMOTT sits in SYLVIA'S chair, DANIEL in MRS. DERMOTT'S.*)

DANIEL. Well, they seem to have upset everything else.

(*Enter GRIGGS, R.*)

MRS. DERMOTT. Bring some more toast and coffee, Griggs. Or would you rather have tea?

DANIEL. Tea, please.

MRS. DERMOTT. Tea then, Griggs.

GRIGGS. Very good, madam. (*Picks up remains of paper above Chesterfield and exit R.*)

SYLVIA (*handing him plate of mushrooms and bacon*). Here you are, uncle dear—I'm going upstairs. Call me if you want anything.

(*Exit SYLVIA upstairs.*)

DANIEL. I will.

MRS. DERMOTT. I'm sure he won't.

DANIEL. Now look here, Anne, you're not to include Sylvia in your fury against the family. She has been perfectly sweet.

MRS. DERMOTT. So she ought to be—and the others as well. Such nonsense, I never heard of such a thing. Not being able to take a joke better than that. I don't know what's happened to them, they were such dear good-natured children. They used to make booby traps and apple-pie beds for one another and not mind a bit.

(MRS. DERMOTT *keeps buttering toast for him, arranging it round his plate.*)

DANIEL. But you see, Anne, this perhaps has irritated them more than an apple-pie bed.

MRS. DERMOTT. I don't see why, it's just as harmless, and much less trouble.

DANIEL. If I had known they were going to take it so badly I should have thought of something else. I have lots of ideas. But even now, when I come to look back over everything, I don't see what else I could have done.

MRS. DERMOTT. You're just the kindest old darling in the world and everything, every single thing you have done for us, has been perfect.

DANIEL. Dear Anne, don't be absurd. It was nothing, worse than nothing, but I'd given it a lot of thought, and after all it has bucked them up and made them work. They're looking much better in health, too.

MRS. DERMOTT. Oh, Danny, I only wish you were better in health. The shadow of your illness just hangs over me like a nightmare. I can't pass a flower shop without thinking of you.

DANIEL (*puts down knife and fork*). But I'm not ill at all. I've no intention of dying until I'm eighty-three or even eighty-four.

MRS. DERMOTT. Dear old boy, you're only saying that so that I shan't worry. (*She dabs her eyes.*) But it's no use, you can't deceive me, you know.

DANIEL. But, Anne, I swear.—

MRS. DERMOTT. There, there, we'll say no more about it. It only upsets me and here's your tea.

(*She takes tea from GRIGGS, who has entered with tea and toast. He goes off again.*)

Have you seen your doctor lately?

DANIEL (*resignedly*). Yes, I saw him the other day.

MRS. DERMOTT (*pouring out tea*). And what did he say?

DANIEL (*confused*). Well—er—I don't know—he sounded me.

MRS. DERMOTT. Yes, they always do that. I wonder why. Your illness has nothing to do with your heart has it?

DANIEL (*firmly*). My dear Anne, I haven't got an illness.

MRS. DERMOTT. I'm sure I hope not, dear, but if he said that, I should really get another more expert opinion if I were you. A man like that can't be really reliable. I don't believe in doctors ever since poor Millicent Jenkins died.

DANIEL. Look here, Anne, I really do want to make you understand that what I told the children is perfectly true. I haven't any money.

MRS. DERMOTT. Nonsense, dear, you can't pull my leg as easily as that. How were you able to send that cheque when I most needed it, and those lovely Christmas presents, and the fares backwards and forwards to America—I believe you've got some big surprise for us all later on and you're afraid that we'll guess it.

DANIEL. Yes, I have.

MRS. DERMOTT (*rising*). Now look here, dear, I must leave you for a little while. Saturday is the busiest morning in the whole week. Finish off your breakfast and smoke a pipe—or a cigar or something; if any of the children come near you, just ignore them or pretend to be frightfully angry with them. That will bring them round.

(*Enter GRIGGS hurriedly, R.*)

GRIGGS. If you please, madam, the boiler is making the most peculiar noises. Shall I send for Brown to come and look at it?

MRS. DERMOTT. I don't think that will do it any good, but still perhaps you'd better. I'll come myself in a minute.

(*Exit GRIGGS, R.*)

MRS. DERMOTT (C.). Really, everything is going wrong this morning, first you, Danny, then the boiler; sometimes life isn't worth living—I do hope it won't burst.

(Exit MRS. DERMOTT, R. DANIEL *sits thoughtful for a moment and then resumes his breakfast. Enter JOYCE from garden. She sees UNCLE DANIEL and comes rather sheepishly up to him.*)

JOYCE. Uncle, I—

DANIEL (*gruffly*). Good morning.

JOYCE (*feebly*). Good morning. (*There is a long pause.*) Uncle Daniel—we've—er—we've all been talking—

DANIEL. That's quite a natural and healthy occupation.

JOYCE. We—we were talking about you.

DANIEL. That makes it none the less natural or healthy.

JOYCE. Of course it didn't. You see—I mean to say—we—well, they sent me in to tell you that—

DANIEL. Perhaps you'd better tell me another time when you are more in the mood. Have you seen the papers anywhere?

JOYCE. They ought to be over there. (*She points to window seat R., and goes down to BOBBIE'S chair.*)

DANIEL (*rising and moving quickly to R.*). Thanks. Don't you bother—I can get my own paper. (*Gets newspaper and returns to his seat at the head of the table.*)

(*There is a long silence, DANIEL reads the paper. JOYCE shakes her head as OLIVER strolls in from the garden and looks at JOYCE for news.*)

OLIVER. Have you had your breakfast, uncle?

DANIEL. Yes, thank you, and I slept beautifully.

OLIVER. It's a jolly nice morning.

DANIEL. That remark makes up in truth for what it lacks in originality.

OLIVER. Oh. (*Moves to window, L.C., turns, catches DANIEL'S eye and turns quickly back.*)

(*JOYCE continues to fidget at the foot of the table. Enter BOBBIE downstairs and EVANGELINE, R. They look meaningly at JOYCE, who shakes her head vigorously.*)

DANIEL. Have you a headache, Joyce, you keep wagging it about.

JOYCE (*very politely*). No, thank you, uncle, I—

DANIEL. Splendid, then I shan't have to offer you an aspirin.

EVANGELINE and BOBBIE (*together, coming forward hand-in-hand down R.C.*). Uncle, we've all been — (*They stop.*)

DANIEL. Yes?

(*There is business of each of them wishing the other to speak to DANIEL.*)

Tell me one thing, if any of you are capable of uttering a word, is this a game? Have I got to guess whether something's a vegetable or a mineral or something?

EVANGELINE. No, uncle, it's a much harder game than that—for us, anyhow. We've come to apologise.

DANIEL (*lowering the paper*). Oh, have you? (*Turns to them.*)

EVANGELINE. Oh, won't you please be nice and make it easier for us?

DANIEL. You none of you made things in the least easy for me.

EVANGELINE. I know we didn't, but we're all sorry—frightfully sorry—we've talked it all over. Sylvia said we were beasts and ghouls and we wouldn't admit it then, but we do now. We are terribly ashamed of the way we've behaved. Please, please say you forgive us. (*Kneels to him.*)

BOBBIE (*placing chair behind Chesterfield*). And it doesn't matter about Faith, uncle, I'm glad you were the means of showing her up. I don't love her a bit now. I hate her, and we all want you to understand that we'd rather have you alive and with us than all the beastly money in the world.

JOYCE (*leaning forward over table*). And we'll do anything you like to atone for it. We'll abase ourselves like they used to in the olden days to show they repented.

OLIVER. Will you let it go at that, uncle? (*He comes forward to L. of DANIEL.*)

DANIEL (*softly*). I should just think I will. (*Kisses EVANGELINE.*)

(JOYCE *comes round and kisses him. OLIVER moves down L. EVANGELINE moves behind table.*)

JOYCE (*running to R.*). Sylvia! Sylvia! Mother, come here! It's all right!

(*Enter MRS. DERMOTT from R.*)

MRS. DERMOTT. I've just come out of the boiler. What on earth is all this noise?

JOYCE. We've all made it up with Uncle Daniel and he's forgiven us.

MRS. DERMOTT. I'm sure I'm very glad, darlings, and I hope you're none of you too old to take a lesson from it. (*Comes to DANIEL'S R.*)

(*Enter SYLVIA downstairs.*)

SYLVIA. Is everything forgiven and forgotten?

DANIEL. Everything. (*Rising.*)

(*Enter GRIGGS, R., with cablegram.*)

GRIGGS (*handing it to UNCLE DANIEL*). For you, sir.

DANIEL. Excuse me. (*Takes it, opens it in silence and reads it.*) My God!

MRS. DERMOTT. What is it, dear, what is it?

DANIEL. It's not true! After all these years, I can't believe it!

SYLVIA. What is it, Uncle, tell us, tell us, quick.

DANIEL. It's from my agent. Listen! (*Reads.*) "Struck big vein, Santa Lyta mine—come at once!" I'm worth thousands, thousands. (*Going down R. gives MRS. DERMOTT telegram as he passes her. The others, except SYLVIA, crowd round her C., excited at the news.*)

MRS. DERMOTT. There now.... I told you so.

SYLVIA (*coming L. of him*). Uncle! Did you send that telegram to yourself?

UNCLE. Yes!!!

CURTAIN.

Words by **ROSE WYNN** "Faith." Music by **NOEL COWARD**



Andante grazioso.

f *Diminuendo.*

ritard. *a tempo.*

1st ver. *2nd ver.*

pp *p* *fz* *pp* *fz*

Fine.

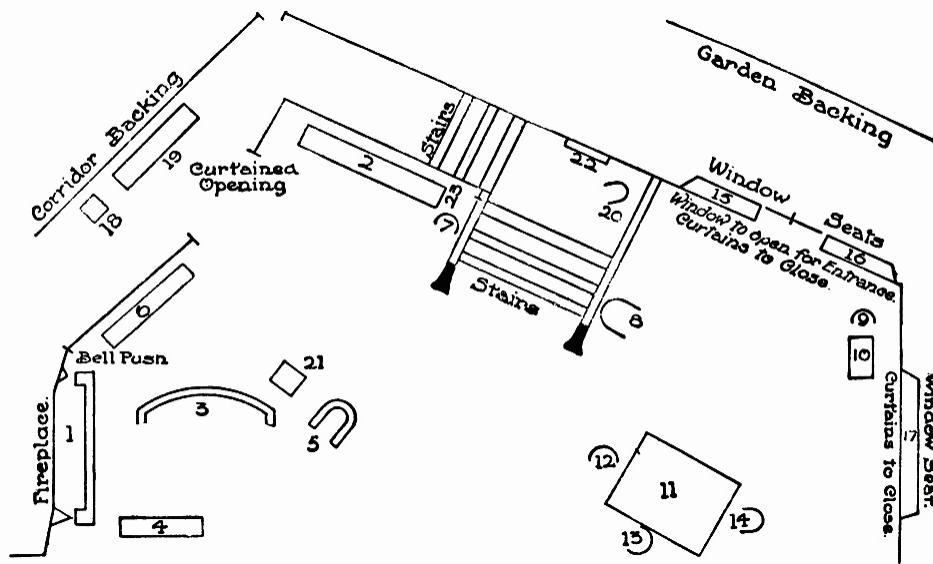

This scene plot indicates how the scene was set at the New Theatre, London. The play can be given, of course, without a staircase.

ACT I

1. Club fender.
2. Small sideboard.
3. Chesterfield.
4. Jacobean form.
5. Armchair.
6. Small sideboard.
7. Chair.
8. Armchair.
9. Chair.
10. Small table.
11. Expanding table. If difficulty is experienced in obtaining an expanding table, a small table can be used for the first two acts and a table of sufficient size to seat three people on one side substituted for the last act.
- 12, 13 and 14. Chairs.
- 15, 16 and 17. Cushions.
18. Gong.
19. Hall stand and hats.
20. Chair.
21. Small table.
22. Mirror.
23. Electric light switch.

ALTERATIONS FOR ACT II

- Open out all curtains in windows.
- Open window up L.C.
- Remove 2 and 7.
- Substitute in their places a Baby Grand piano and a piano stool.
- Bring 9 and 10 down to above table (11)—the chair facing window L.
- Change cushions.
- Place model of motor on piano.
- Place typewriter on 10, cover beside it.
- Change flowers.
- Place papers on window seats, Chesterfield, table and form.
- Flowers in grate.
- Ash tray on club fender.
- Matches on mantel.
- Syphon and glasses on sideboard.
- Writing materials and music paper on 11.

ALTERATIONS FOR ACT III

Put back 10 to original position.
Change 12 and 5.
Put 4 by table, side nearest the audience.
Place 7, 9, 14 on opposite side.
13 at foot of table, nearest window L.
Lay breakfast for eight on table, consisting of rose bowl in centre, toast rack, marmalade, entrée dish, plate of bread, butter, tray of teacups, etc., sugar, pile of plates, and for each person a bread plate, a serviette, a fork, two knives.
Remove racquet and models.
Close piano.
Put cover on typewriter.
Remove most papers, ash trays, etc.
Remove everything from sideboard.
Place daily papers on window seat L.
Letter on table.

PROPERTY PLOT

ACT I

Carpet.
Rugs.
Chesterfield.
2 sideboards (Jacobean).
Club fender.
Low form (Jacobean).
Oblong table (Jacobean) to seat 8.
Typewriter table.
Armchair.
6 small chairs: Jacobean.
2 armchairs: Jacobean.
2 pairs window curtains.
Cushions on window seats.
Pictures (hunting prints).
Book (Evangeline) off R.
Telegram (Griggs) off R. on salver.
Door bell effect off R.
Books and periodicals on table.
Crêpe-de-chine "undies."
Fire-irons, etc.
Winter flowers in vases.
Salver (off R.).
Hall-stand.
Coats, hats, etc.
Mirror on stairs.

ACT II

Typewriter with cover.
Miscellaneous papers.
Model of motor engine on board on piano.
Manuscript music paper on table.
Writing materials on table.
Pencil (Bobbie).
Baby Grand piano and stool.
Quantity of sheet music.
Door knock effect off R.
Knitting (Evangeline) off R.
Illustrated papers.
Motor horn effect off R.
Matches on mantel.
Tantalus on sideboard R.
Syphon of soda.
2 glasses (whisky).
Cigarette case (Daniel).
Cigarette case (Mrs. Crombie).

Glass jug of water.
Telegram (Mrs. Dermott off L.).
Tennis Racquet off R.
Cigarettes.
Ash tray on club fender.
Waste-paper basket.
Bank of flowers in fireplace.

ACT III

5 morning papers on window seat L.C.
Bunch of roses (Sylvia) off R.
Suit case (Daniel) off R.C.
Gong and beater off R.
Flower bowl.
Letter on table.
Teapot off R. with tea for one.
Cablegram off R.
Plate, fork and spoon on sideboard.
Paper on Chesterfield.
Breakfast for 8 people as follows:—
Large silver tray for teacups.
Small silver tray off R.
Tablecloth.
Table centre.
8 medium plates.
8 small plates.
16 knives (small).
8 forks (small).
8 breakfast cups and saucers on silver tray.
8 spoons.
8 serviettes.
Cruet.
2 toast racks and toast.
1 toast rack and toast off R.
Marmalade dish and marmalade.
Butter dish and "butter."
Sugar bowl and sugar.
Spoons for sugar and marmalade.
Entrée dish with "bacon."
Entrée dish with mushrooms off R.
2 large spoons and forks.
Cut bread on plate.
Coffee urn and coffee off R. (for five).
Milk jug and hot milk off R.
Bread fork.
Sugar tongs.
Rosebowl.
Butter knife.

ELECTRIC PLOT

ACT I.

Table lamp on table L.C.] connected by practical switch R. side of
Hanging lamp on stairs.] Bannisters *out* to open.
2 wall brackets.
Bell push above fireplace.
Fire (alight).
Red lime in fireplace.
Floats. C. and O.P. sections, *white*, slightly down on resistance to open.
No. 1 batten. C. section only. *White*.
P. perches. Dark amber to open.
O.P. perches. 1 red, 1 dark amber.
Light amber on garden backings.
Lengths in corridor and stairway.
At Cue. "*Thank God I've got you.*" Slowly check floats, batten, and backing limes (garden).

At Cue. "Do let's hurry." Bring up floats and No. 1 batten as BOBBIE switches on lamps. Change P. perches to light amber and O.P. red to dark amber.
At Cue. Sylvia drawing curtains, slowly check backing limes *out.*

ACTS II AND III.

Same sections of *floats* and *batten* as Act I.

Full up, *white.*

O.P. perches, light amber.

P. perches, flood white.

Garden backings flood white, and into room fire off. Lamps and brackets off.

MADE AND PRINTED IN GREAT BRITAIN BY WHITSTABLE LITHO LTD., WHITSTABLE, KENT

NOEL COWARD

I'LL LEAVE IT TO YOU

ISBN 0 573 01199 0

*** END OF THE PROJECT GUTENBERG EBOOK "I'LL LEAVE IT TO YOU": A LIGHT COMEDY
IN THREE ACTS ***

Updated editions will replace the previous one—the old editions will be renamed.

Creating the works from print editions not protected by U.S. copyright law means that no one owns a United States copyright in these works, so the Foundation (and you!) can copy and distribute it in the United States without permission and without paying copyright royalties. Special rules, set forth in the General Terms of Use part of this license, apply to copying and distributing Project Gutenberg™ electronic works to protect the PROJECT GUTENBERG™ concept and trademark. Project Gutenberg is a registered trademark, and may not be used if you charge for an eBook, except by following the terms of the trademark license, including paying royalties for use of the Project Gutenberg trademark. If you do not charge anything for copies of this eBook, complying with the trademark license is very easy. You may use this eBook for nearly any purpose such as creation of derivative works, reports, performances and research. Project Gutenberg eBooks may be modified and printed and given away—you may do practically ANYTHING in the United States with eBooks not protected by U.S. copyright law. Redistribution is subject to the trademark license, especially commercial redistribution.

START: FULL LICENSE

THE FULL PROJECT GUTENBERG LICENSE

To protect the Project Gutenberg™ mission of promoting the free distribution of electronic works, by using or distributing this work (or any other work associated in any way with the phrase “Project Gutenberg”), you agree to comply with all the terms of the Full Project Gutenberg™ License available with this file or online at www.gutenberg.org/license.

Section 1. General Terms of Use and Redistributing Project Gutenberg™ electronic works

1.A. By reading or using any part of this Project Gutenberg™ electronic work, you indicate that you have read, understand, agree to and accept all the terms of this license and intellectual property (trademark/copyright) agreement. If you do not agree to abide by all the terms of this agreement, you must cease using and return or destroy all copies of Project Gutenberg™ electronic works in your possession. If you paid a fee for obtaining a copy of or access to a Project Gutenberg™ electronic work and you do not agree to be bound by the terms of this agreement, you may obtain a refund from the person or entity to whom you paid the fee as set forth in paragraph 1.E.8.

1.B. “Project Gutenberg” is a registered trademark. It may only be used on or associated in any way with an electronic work by people who agree to be bound by the terms of this agreement. There are a few things that you can do with most Project Gutenberg™ electronic works even without complying with the full terms of this agreement. See paragraph 1.C below. There are a lot of things you can do with Project Gutenberg™ electronic works if you follow the terms of this agreement and help preserve free future access to Project Gutenberg™ electronic works. See paragraph 1.E below.

1.C. The Project Gutenberg Literary Archive Foundation (“the Foundation” or PGLAF), owns a compilation copyright in the collection of Project Gutenberg™ electronic works. Nearly all the individual works in the collection are in the public domain in the United States. If an individual work is unprotected by copyright law in the United States and you are located in the United States, we do not claim a right to prevent you from copying, distributing, performing, displaying or creating derivative works based on the work as long as all references to Project Gutenberg are removed. Of course, we hope that you will support the Project Gutenberg™ mission of promoting free access to electronic works by freely sharing Project Gutenberg™ works in compliance with the terms of this agreement for keeping the Project Gutenberg™ name associated with the work. You can easily comply with the terms of this agreement by keeping this work in the same format with its attached full Project Gutenberg™ License when you share it without charge with others.

1.D. The copyright laws of the place where you are located also govern what you can do with this work. Copyright laws in most countries are in a constant state of change. If you are outside the United States, check the laws of your country in addition to the terms of this agreement before downloading, copying, displaying, performing, distributing or creating derivative works based on this work or any other Project Gutenberg™ work. The Foundation makes no representations concerning the copyright status of any work in any country other than the United States.

1.E. Unless you have removed all references to Project Gutenberg:

1.E.1. The following sentence, with active links to, or other immediate access to, the full Project Gutenberg™ License must appear prominently whenever any copy of a Project Gutenberg™ work (any work on which the phrase “Project Gutenberg” appears, or with which the phrase “Project Gutenberg” is associated) is accessed, displayed, performed, viewed, copied or distributed:

This eBook is for the use of anyone anywhere in the United States and most other parts of the world at no cost and with almost no restrictions whatsoever. You may copy it, give it away or re-use it under the terms of the Project Gutenberg License included with this eBook or online at www.gutenberg.org. If you are not located in the United States, you will have to check the laws of the country where you are located before using this eBook.

1.E.2. If an individual Project Gutenberg™ electronic work is derived from texts not protected by U.S. copyright law (does not contain a notice indicating that it is posted with permission of the copyright holder), the work can be copied and distributed to anyone in the United States without paying any fees or charges. If you are redistributing or providing access to a work with the phrase “Project Gutenberg” associated with or appearing on the work, you must comply either with the requirements of paragraphs 1.E.1 through 1.E.7 or obtain permission for the use of the work and the Project Gutenberg™ trademark as set forth in paragraphs 1.E.8 or 1.E.9.

1.E.3. If an individual Project Gutenberg™ electronic work is posted with the permission of the copyright holder, your use and distribution must comply with both paragraphs 1.E.1 through 1.E.7 and any additional terms imposed by the copyright holder. Additional terms will be linked to the Project Gutenberg™ License for all works posted with the permission of the copyright holder found at the beginning of this work.

1.E.4. Do not unlink or detach or remove the full Project Gutenberg™ License terms from this work, or any files containing a part of this work or any other work associated with Project

Gutenberg™.

1.E.5. Do not copy, display, perform, distribute or redistribute this electronic work, or any part of this electronic work, without prominently displaying the sentence set forth in paragraph 1.E.1 with active links or immediate access to the full terms of the Project Gutenberg™ License.

1.E.6. You may convert to and distribute this work in any binary, compressed, marked up, nonproprietary or proprietary form, including any word processing or hypertext form. However, if you provide access to or distribute copies of a Project Gutenberg™ work in a format other than "Plain Vanilla ASCII" or other format used in the official version posted on the official Project Gutenberg™ website (www.gutenberg.org), you must, at no additional cost, fee or expense to the user, provide a copy, a means of exporting a copy, or a means of obtaining a copy upon request, of the work in its original "Plain Vanilla ASCII" or other form. Any alternate format must include the full Project Gutenberg™ License as specified in paragraph 1.E.1.

1.E.7. Do not charge a fee for access to, viewing, displaying, performing, copying or distributing any Project Gutenberg™ works unless you comply with paragraph 1.E.8 or 1.E.9.

1.E.8. You may charge a reasonable fee for copies of or providing access to or distributing Project Gutenberg™ electronic works provided that:

- You pay a royalty fee of 20% of the gross profits you derive from the use of Project Gutenberg™ works calculated using the method you already use to calculate your applicable taxes. The fee is owed to the owner of the Project Gutenberg™ trademark, but he has agreed to donate royalties under this paragraph to the Project Gutenberg Literary Archive Foundation. Royalty payments must be paid within 60 days following each date on which you prepare (or are legally required to prepare) your periodic tax returns. Royalty payments should be clearly marked as such and sent to the Project Gutenberg Literary Archive Foundation at the address specified in Section 4, "Information about donations to the Project Gutenberg Literary Archive Foundation."
- You provide a full refund of any money paid by a user who notifies you in writing (or by e-mail) within 30 days of receipt that s/he does not agree to the terms of the full Project Gutenberg™ License. You must require such a user to return or destroy all copies of the works possessed in a physical medium and discontinue all use of and all access to other copies of Project Gutenberg™ works.
- You provide, in accordance with paragraph 1.F.3, a full refund of any money paid for a work or a replacement copy, if a defect in the electronic work is discovered and reported to you within 90 days of receipt of the work.
- You comply with all other terms of this agreement for free distribution of Project Gutenberg™ works.

1.E.9. If you wish to charge a fee or distribute a Project Gutenberg™ electronic work or group of works on different terms than are set forth in this agreement, you must obtain permission in writing from the Project Gutenberg Literary Archive Foundation, the manager of the Project Gutenberg™ trademark. Contact the Foundation as set forth in Section 3 below.

1.F.

1.F.1. Project Gutenberg volunteers and employees expend considerable effort to identify, do copyright research on, transcribe and proofread works not protected by U.S. copyright law in creating the Project Gutenberg™ collection. Despite these efforts, Project Gutenberg™ electronic works, and the medium on which they may be stored, may contain "Defects," such as, but not limited to, incomplete, inaccurate or corrupt data, transcription errors, a copyright or other intellectual property infringement, a defective or damaged disk or other medium, a computer virus, or computer codes that damage or cannot be read by your equipment.

1.F.2. LIMITED WARRANTY, DISCLAIMER OF DAMAGES - Except for the "Right of Replacement or Refund" described in paragraph 1.F.3, the Project Gutenberg Literary Archive Foundation, the owner of the Project Gutenberg™ trademark, and any other party distributing a Project Gutenberg™ electronic work under this agreement, disclaim all liability to you for damages, costs and expenses, including legal fees. YOU AGREE THAT YOU HAVE NO REMEDIES FOR NEGLIGENCE, STRICT LIABILITY, BREACH OF WARRANTY OR BREACH OF CONTRACT EXCEPT THOSE PROVIDED IN PARAGRAPH 1.F.3. YOU AGREE THAT THE FOUNDATION, THE TRADEMARK OWNER, AND ANY DISTRIBUTOR UNDER THIS AGREEMENT WILL NOT BE LIABLE TO YOU FOR ACTUAL, DIRECT, INDIRECT, CONSEQUENTIAL, PUNITIVE OR INCIDENTAL DAMAGES EVEN IF YOU GIVE NOTICE OF THE POSSIBILITY OF SUCH DAMAGE.

1.F.3. LIMITED RIGHT OF REPLACEMENT OR REFUND - If you discover a defect in this electronic work within 90 days of receiving it, you can receive a refund of the money (if any) you paid for it by sending a written explanation to the person you received the work from. If you received the work on a physical medium, you must return the medium with your written explanation. The person or entity that provided you with the defective work may elect to provide a replacement copy in lieu of a refund. If you received the work electronically, the person or entity providing it to you may choose to give you a second opportunity to receive the work electronically in lieu of a refund. If the second copy is also defective, you may demand a refund in writing without further opportunities to fix the problem.

1.F.4. Except for the limited right of replacement or refund set forth in paragraph 1.F.3, this work is provided to you 'AS-IS', WITH NO OTHER WARRANTIES OF ANY KIND, EXPRESS OR IMPLIED, INCLUDING BUT NOT LIMITED TO WARRANTIES OF MERCHANTABILITY OR FITNESS FOR ANY PURPOSE.

1.F.5. Some states do not allow disclaimers of certain implied warranties or the exclusion or limitation of certain types of damages. If any disclaimer or limitation set forth in this agreement violates the law of the state applicable to this agreement, the agreement shall be interpreted to make the maximum disclaimer or limitation permitted by the applicable state law. The invalidity or unenforceability of any provision of this agreement shall not void the remaining provisions.

1.F.6. INDEMNITY - You agree to indemnify and hold the Foundation, the trademark owner, any agent or employee of the Foundation, anyone providing copies of Project Gutenberg™ electronic works in accordance with this agreement, and any volunteers associated with the production, promotion and distribution of Project Gutenberg™ electronic works, harmless from all liability, costs and expenses, including legal fees, that arise directly or indirectly from any of the following which you do or cause to occur: (a) distribution of this or any Project Gutenberg™ work, (b) alteration, modification, or additions or deletions to any Project Gutenberg™ work, and (c) any Defect you cause.

Section 2. Information about the Mission of Project Gutenberg™

Project Gutenberg™ is synonymous with the free distribution of electronic works in formats readable by the widest variety of computers including obsolete, old, middle-aged and new computers. It exists because of the efforts of hundreds of volunteers and donations from people in all walks of life.

Volunteers and financial support to provide volunteers with the assistance they need are critical to reaching Project Gutenberg™'s goals and ensuring that the Project Gutenberg™ collection will remain freely available for generations to come. In 2001, the Project Gutenberg Literary Archive Foundation was created to provide a secure and permanent future for Project Gutenberg™ and future generations. To learn more about the Project Gutenberg Literary Archive Foundation and how your efforts and donations can help, see Sections 3 and 4 and the Foundation information page at www.gutenberg.org.

Section 3. Information about the Project Gutenberg Literary Archive Foundation

The Project Gutenberg Literary Archive Foundation is a non-profit 501(c)(3) educational corporation organized under the laws of the state of Mississippi and granted tax exempt status by the Internal Revenue Service. The Foundation's EIN or federal tax identification number is 64-6221541. Contributions to the Project Gutenberg Literary Archive Foundation are tax deductible to the full extent permitted by U.S. federal laws and your state's laws.

The Foundation's business office is located at 809 North 1500 West, Salt Lake City, UT 84116, (801) 596-1887. Email contact links and up to date contact information can be found at the Foundation's website and official page at www.gutenberg.org/contact

Section 4. Information about Donations to the Project Gutenberg Literary Archive Foundation

Project Gutenberg™ depends upon and cannot survive without widespread public support and donations to carry out its mission of increasing the number of public domain and licensed works that can be freely distributed in machine-readable form accessible by the widest array of equipment including outdated equipment. Many small donations (\$1 to \$5,000) are particularly important to maintaining tax exempt status with the IRS.

The Foundation is committed to complying with the laws regulating charities and charitable donations in all 50 states of the United States. Compliance requirements are not uniform and it takes a considerable effort, much paperwork and many fees to meet and keep up with these requirements. We do not solicit donations in locations where we have not received written confirmation of compliance. To SEND DONATIONS or determine the status of compliance for any particular state visit www.gutenberg.org/donate.

While we cannot and do not solicit contributions from states where we have not met the solicitation requirements, we know of no prohibition against accepting unsolicited donations from donors in such states who approach us with offers to donate.

International donations are gratefully accepted, but we cannot make any statements concerning tax treatment of donations received from outside the United States. U.S. laws alone swamp our small staff.

Please check the Project Gutenberg web pages for current donation methods and addresses. Donations are accepted in a number of other ways including checks, online payments and credit card donations. To donate, please visit: www.gutenberg.org/donate

Section 5. General Information About Project Gutenberg™ electronic works

Professor Michael S. Hart was the originator of the Project Gutenberg™ concept of a library of electronic works that could be freely shared with anyone. For forty years, he produced and distributed Project Gutenberg™ eBooks with only a loose network of volunteer support.

Project Gutenberg™ eBooks are often created from several printed editions, all of which are confirmed as not protected by copyright in the U.S. unless a copyright notice is included. Thus, we do not necessarily keep eBooks in compliance with any particular paper edition.

Most people start at our website which has the main PG search facility: www.gutenberg.org.

This website includes information about Project Gutenberg™, including how to make donations to the Project Gutenberg Literary Archive Foundation, how to help produce our new eBooks, and how to subscribe to our email newsletter to hear about new eBooks.