

The Project Gutenberg eBook of The Seven Follies of Science [2nd ed.], by John Phin

This ebook is for the use of anyone anywhere in the United States and most other parts of the world at no cost and with almost no restrictions whatsoever. You may copy it, give it away or re-use it under the terms of the Project Gutenberg License included with this ebook or online at [www.gutenberg.org](http://www.gutenberg.org). If you are not located in the United States, you'll have to check the laws of the country where you are located before using this eBook.

Title: The Seven Follies of Science [2nd ed.]

Author: John Phin

Release date: June 28, 2011 [EBook #36547]

Language: English

Credits: Produced by Jonathan Ingram, Stephen Blundell and the Online Distributed Proofreading Team at <http://www.pgdp.net> (This file was produced from images generously made available by The Internet Archive/American Libraries.)

\*\*\* START OF THE PROJECT GUTENBERG EBOOK THE SEVEN FOLLIES OF SCIENCE [2ND ED.] \*\*\*

# THE SEVEN FOLLIES OF SCIENCE

A

POPULAR ACCOUNT OF THE MOST FAMOUS

## SCIENTIFIC IMPOSSIBILITIES

AND THE ATTEMPTS WHICH HAVE BEEN MADE TO SOLVE THEM.

TO WHICH IS ADDED A SMALL BUDGET OF INTERESTING  
PARADOXES, ILLUSIONS, AND MARVELS.

WITH NUMEROUS ILLUSTRATIONS

BY

JOHN PHIN

AUTHOR OF "HOW TO USE THE MICROSCOPE"; "THE WORKSHOP COMPANION";  
"THE SHAKESPEARE CYCLOPEDIA"; EDITOR MARQUIS OF WORCESTER'S,  
"CENTURY OF INVENTIONS"; ETC.

**SECOND EDITION**



NEW YORK  
D. VAN NOSTRAND COMPANY  
23 MURRAY AND 27 WARREN STS.  
1906

---

## PREFACE

[iii]

IN the following pages I have endeavored to give a simple account of problems which have occupied the attention of the human mind ever since the dawn of civilization, and which can never lose their interest until time shall be no more. While to most persons these subjects will have but an historical interest, yet even from this point of view they are of more value than the history of empires, for they are the intellectual battlefields upon which much of our progress in science has been won. To a few, however, some of them may be of actual practical importance, for although the schoolmaster has been abroad for these many years, it is an unfortunate fact that the circle-squarer and the perpetual-motion-seeker have not ceased out of the land.

In these days of almost miraculous progress it is difficult to realize that there may be such a thing as a scientific impossibility. I have therefore endeavored to point out where the line must be drawn, and by way of illustration I have added a few curious paradoxes and marvels, some of which show apparent contradictions to known laws of nature, but which are all simply and easily explained when we understand the fundamental principles which govern each case.

In presenting the various subjects which are here discussed, I have endeavored to use the simplest language and to avoid entirely the use of mathematical formulae, for I know by large experience that these are the bugbear of the ordinary reader, for whom this volume is specially intended. Therefore I have endeavored to state everything in such a simple manner that any one with a mere common school education can understand it. This, I trust, will explain the absence of everything which requires the use of anything higher than the simple rules of arithmetic and the most elementary propositions of geometry. And even this I have found to be enough for many lawyers, physicians, and clergymen who, in the ardent pursuit of their professions, have forgotten much that they learned at college. And as I hope to find many readers amongst intelligent mechanics, I have in some cases suggested mechanical proofs which any expert handler of tools can easily carry out.

[iv]

As a matter of course, very little originality is claimed for anything in the book,—the only points that are new being a few illustrations of well-known principles, some of which had already appeared in "The Young Scientist" and "Self-education for Mechanics." Whenever the exact words of an author have been used, credit has always been given; but in regard to general statements and ideas, I must rest content with naming the books from which I have derived the greatest assistance. Ozanam's "Recreations in Science and Natural Philosophy," in the editions of Hutton (1803) and Riddle (1854), has been a storehouse of matter. Much has been gleaned from the "Budget of Paradoxes" by Professor De Morgan and also from Professor W. W. R. Ball's "Mathematical Recreations and Problems." Those who wish to inform themselves in regard to what has been done by the perpetual-motion-mongers must consult Mr. Dirck's two volumes entitled "Perpetuum Mobile" and I have made free use of his labors. To these and one or two others I acknowledge unlimited credit.

[v]

Some of the marvels which are here described, although very old, are not generally known, and as they are easily put in practice they may afford a pleasant hour's amusement to the reader and his friends.

JOHN PHIN

*Paterson, N. J., July, 1905.*

---

## CONTENTS

[vii]

### Preface

#### THE SEVEN FOLLIES OF SCIENCE

	PAGE
Introductory Note	1
I Squaring the Circle	9
II The Duplication of the Cube	30
III The Trisection of an Angle	33
IV Perpetual Motion	36
V The Transmutation of Metals—Alchemy	79

VI The Fixation of Mercury	92
VII The Universal Medicine and the Elixir of Life	95

ADDITIONAL FOLLIES

Perpetual or Ever-burning Lamps	100
The Alkahest or Universal Solvent	104
Palingenesy	106
The Powder of Sympathy	111

A SMALL BUDGET OF PARADOXES, ILLUSIONS, AND MARVELS (WITH APOLOGIES TO PROFESSOR DE MORGAN)

The Fourth Dimension	117
How a Space may be apparently Enlarged by merely changing its Shape	126
Can a Man Lift Himself by the Straps of his Boots?	128
How a Spider Lifted a Snake	130
How the Shadow may be made to move backward on the Sun-dial	133
How a Watch may be used as a Compass	134
Micrography or Minute Writing. Writing so fine that the whole Bible, if written in characters of the same size, might be inscribed twenty-two times on a square inch	136
Illusions of the Senses	149
Taste and Smell	150
Sense of Heat	150
Sense of Hearing	150
Sense of Touch—One Thing Appearing as Two	151
How Objects may be apparently Seen through a Hole in the Hand	156
How to See (apparently) through a Solid Brick	158

[viii]

CURIOUS ARITHMETICAL PROBLEMS

The Chess-board Problem	163
The Nail Problem	164
A Question of Population	165
How to Become a Millionaire	166
The Actual Cost and Present Value of the First Folio Shakespeare	168
Arithmetical Puzzles	170
Archimedes and His Fulcrum	171

---

## THE SEVEN FOLLIES OF SCIENCE

[1]



HE difficult, the dangerous, and the impossible have always had a strange fascination for the human mind. We see this every day in the acts of boys who risk life and limb in the performance of useless but dangerous feats, and amongst children of larger growth we find loop-the-loopers, bridge-jumpers, and all sorts of venture-seekers to whom much of the attraction of these performances is undoubtedly the mere risk that is involved, although, perhaps, to some extent, notoriety and money-making may contribute their share. Many of our readers will doubtless remember the words of James Fitz-James, in "The Lady of the Lake":

Or, if a path be dangerous  
known  
The danger's self is lure  
alone.

And in commenting on the old-time game laws of England, Froude, the historian, says: "Although the old forest laws were terrible, they served only to enhance the excitement by danger."

That which is true of physical dangers holds equally true in regard to intellectual difficulties. Professor De Morgan tells us, in his "Budget of Paradoxes," that he once gave a lecture on "Squaring the Circle" and that a gentleman who was introduced to it by what he said, remarked loud enough to be heard by all around: "Only prove to me that it is impossible and I will set about it this very evening."

[2]

Therefore it is not to be wondered at that certain very difficult, or perhaps impossible problems have in all ages had a powerful fascination for certain minds. In that curious *olla podrida* of fact and fiction, "The Curiosities of Literature," D'Israeli gives a list of six of these problems, which he calls "The Six Follies of Science." I do not know whether the phrase "Follies of Science" originated with him or not, but he enumerates the Quadrature of the Circle; the Duplication, or, as he calls it, the Multiplication of the Cube; the Perpetual Motion; the Philosophical Stone; Magic, and Judicial Astrology, as those known to him. This list, however, has no classical standing such as pertains to the "Seven Wonders of the World," the "Seven Wise Men of Greece," the "Seven Champions of Christendom," and others. There are some well-known follies that are omitted, while some authorities would peremptorily reject Magic and Judicial Astrology as being attempts at fraud rather than earnest efforts to discover and utilize the secrets of nature. The generally accepted list is as follows:

1. The Quadrature of the Circle or, as it is called in the vernacular, "Squaring the Circle."
2. The Duplication of the Cube.
3. The Trisection of an Angle.
4. Perpetual Motion.
5. The Transmutation of the Metals.
6. The Fixation of Mercury.
7. The Elixir of Life.

The Transmutation of the Metals, the Fixation of Mercury, and the Elixir of Life might perhaps be properly classed as one, under the head of the Philosopher's Stone, and then Astrology and Magic might come in to make up the mystic number Seven. [3]

The expression "Follies of Science" does not seem a very appropriate one. Real science has no follies. Neither can these vain attempts be called *scientific* follies because their very essence is that they are unscientific. Each one is really a veritable "Will-o'-the-Wisp" for unscientific thinkers, and there are many more of them than those that we have here named. But the expression has been adopted in literature and it is just as well to accept it. Those on the list that we have given are the ones that have become famous in history and they still engage the attention of a certain class of minds. It is only a few months since a man who claims to be a professional architect and technical writer put forth an alleged method of "squaring the circle," which he claims to be "exact"; and the results of an attempt to make liquid air a pathway to perpetual motion are still in evidence, as a minus quantity, in the pockets of many who believed that all things are possible to modern science. And indeed it is this false idea of the possibility of the impossible that leads astray the followers of these false lights. Inventive science has accomplished so much—many of her achievements being so astounding that they would certainly have seemed miracles to the most intelligent men of a few generations ago—that the ordinary mind cannot see the difference between unknown possibilities and those things which well-established science pronounces to be impossible, because they contradict fundamental laws which are thoroughly established and well understood.

Thus any one who would claim that he could make a plane triangle in which the three angles would measure more than two right angles, would show by this very claim that he was entirely ignorant of the first principles of geometry. The same would be true of the man who would claim that he could give, in exact figures, the diagonal of a square of which the side is exactly one foot or one yard, and it is also true of the man who claims that he can give the exact area of a circle of which either the circumference or the diameter is known with precision. That they cannot both be known exactly is very well understood by all who have studied the subject, but that the area, the circumference, and the diameter of a circle may all be known with an exactitude which is far in excess of anything of which the human mind can form the least conception, is quite true, as we shall show when we come to consider the subject in its proper place. [4]

These problems are not only interesting historically but they are valuable as illustrating the vagaries of the human mind and the difficulties with which the early investigators had to contend. They also show us the barriers over which we cannot pass, and they enforce the immutable character of the natural laws which govern the world around us. We hear much of the progress of science and of the changes which this progress has brought about, but these changes never affect the fundamental facts and principles upon which all true science is based. Theories and explanations and even practical applications change or pass away, so that we know them no more, but nature remains the same throughout the ages. No new theory of electricity can ever take away from the voltaic battery its power, or change it in any respect, and no new discovery in regard to the constitution of matter can ever lessen the eagerness with which carbon and oxygen combine together. Every little while we hear of some discovery that is going to upset all our preconceived notions and entirely change those laws which long experience has proved to be invariable, but in every case these alleged discoveries have turned out to be fallacies. For example, the wonderful properties of radium have led some enthusiasts to adopt the idea that many of our old notions about the conservation of energy must be abandoned, but when all the facts are carefully examined it is found that there is no rational basis for such views. Upon this point Sir Oliver Lodge says: [5]

"There is absolutely no ground for the popular and gratuitous surmise that radium emits energy without loss or waste of any kind, and that it is competent to go on forever. The idea, at one time irresponsibly mooted, that it contradicted the principle of the conservation of energy, and was troubling physicists with the idea that they must overhaul their theories—a thing which they ought always to be delighted to do on good

evidence—this idea was a gratuitous absurdity, and never had the slightest foundation. It is reasonable to suppose, however, that radium and the other like substances are drawing upon their own stores of internal atomic energy, and thereby gradually disintegrating and falling into other and ultimately more stable forms of matter."

One would naturally suppose that the extensive diffusion of sound scientific knowledge which has taken place during the century just past, would have placed these problems amongst the lumber of past ages; but it seems that some of them, particularly the squaring of the circle and perpetual motion, still occupy considerable space in the attention of the world, and even the futile chase after the "Elixir of Life" has not been entirely abandoned. Indeed certain professors who occupy prominent official positions, assert that they have made great progress towards its attainment. In view of such facts one is almost driven to accept the humorous explanation which De Morgan has offered and which he bases on an old legend relating to the famous wizard, Michael Scott. The generally accepted tradition, as related by Sir Walter Scott in his notes to the "Lay of the Last Minstrel," is as follows:

[6]

"Michael Scott was, once upon a time, much embarrassed by a spirit for whom he was under the necessity of finding constant employment. He commanded him to build a 'cauld,' or dam head across the Tweed at Kelso; it was accomplished in one night, and still does honor to the infernal architect. Michael next ordered that Eildon Hill, which was then a uniform cone, should be divided into three. Another night was sufficient to part its summit into the three picturesque peaks which it now bears. At length the enchanter conquered this indefatigable demon, by employing him in the hopeless task of making ropes out of sea-sand."

Whereupon De Morgan offers the following exceedingly interesting continuation of the legend:

"The recorded story is that Michael Scott, being bound by contract to procure perpetual employment for a number of young demons, was worried out of his life in inventing jobs for them, until at last he set them to make ropes out of sea-sand, which they never could do. We have obtained a very curious correspondence between the wizard Michael and his demon slaves; but we do not feel at liberty to say how it came into our hands. We much regret that we did not receive it in time for the British Association. It appears that the story, true as far as it goes, was never finished. The demons easily conquered the rope difficulty, by the simple process of making the sand into glass, and spinning the glass into thread which they twisted. Michael, thoroughly disconcerted, hit upon the plan of setting some to square the circle, others to find the perpetual motion, etc. He commanded each of them to transmigrate from one human body into another, until their tasks were done. This explains the whole succession of cyclometers and all the heroes of the Budget. Some of this correspondence is very recent; it is much blotted, and we are not quite sure of its meaning. It is full of figurative allusions to driving something illegible down a steep into the sea. It looks like a humble petition to be allowed some diversion in the intervals of transmigration; and the answer is:

[7]

"'Rumpat et serpens iter institutum'

"a line of Horace, which the demons interpret as a direction to come athwart the proceedings of the Institute by a sly trick."

And really those who have followed carefully the history of the men who have claimed that they had solved these famous problems, will be almost inclined to accept De Morgan's ingenious explanation as something more than a mere "skit." The whole history of the philosopher's stone, of machines and contrivances for obtaining perpetual motion, and of circle-squaring, is permeated with accounts of the most gross and obvious frauds. That ignorance played an important part in the conduct of many who have put forth schemes based upon these pretended solutions is no doubt true, but that a deliberate attempt at absolute fraud was the mainspring in many cases cannot be denied. Like *Dousterswivel* in "The Antiquary," many of the men who advocated these delusions may have had a sneaking suspicion that there might be some truth in the doctrines which they promulgated; but most of them knew that their particular claims were groundless, and that they were put forward for the purpose of deceiving some confiding patron from whom they expected either money or the credit and glory of having done that which had been hitherto considered impossible.

[8]

Some of the questions here discussed have been called "scientific impossibilities"—an epithet which many have considered entirely inapplicable to any problem, on the ground that all things are possible to science. And in view of the wonderful things that have been accomplished in the past, some of my readers may well ask: "Who shall decide when doctors disagree?"

Perhaps the best answer to this question is that given by Ozanam, the old historian of these and many other scientific puzzles. He claimed that "it was the business of the Doctors of the Sorbonne to discuss, of the Pope to decide, and of a mathematician to go straight to heaven in a perpendicular line!"

In this connection the words of De Morgan have a deep significance. Alluding to the difficulty of preventing men of no authority from setting up false pretensions and the impossibility of destroying the assertions of fancy speculation, he says: "Many an error of thought and learning has fallen before a gradual growth of thoughtful and learned opposition. But such things as the quadrature of the circle, etc., are never put down. And why? Because thought can influence thought, but thought cannot influence self-conceit; learning can annihilate learning; but learning cannot annihilate ignorance. A sword may cut through an iron bar, and the severed ends will not reunite; let it go through the air, and the yielding substance is whole again in a moment."

## I.

## SQUARING THE CIRCLE

**U**NDoubtedly one of the reasons why this problem has received so much attention from those whose minds certainly have no special leaning towards mathematics, lies in the fact that there is a general impression abroad that the governments of Great Britain and France have offered large rewards for its solution. De Morgan tells of a Jesuit who came all the way from South America, bringing with him a quadrature of the circle and a newspaper cutting announcing that a reward was ready for the discovery in England. As a matter of fact his method of solving the problem was worthless, and even if it had been valuable, there would have been no reward.

Another case was that of an agricultural laborer who spent his hard-earned savings on a journey to London, carrying with him an alleged solution of the problem, and who demanded from the Lord Chancellor the sum of one hundred thousand pounds, which he claimed to be the amount of the reward offered and which he desired should be handed over forthwith. When he failed to get the money he and his friends were highly indignant and insisted that the influence of the clergy had deprived the poor man of his just deserts!

And it is related that in the year 1788, one of these deluded individuals, a M. de Vausenville, actually brought an action against the French Academy of Sciences to recover a reward to which he felt himself entitled. It ought to be needless to say that there never was a reward offered for the solution of this or any other of the problems which are discussed in this volume. Upon this point De Morgan has the following remarks:

[10]

"Montucla says, speaking of France, that he finds three notions prevalent among the cyclometers [or circle-squarers]: 1. That there is a large reward offered for success; 2. That the longitude problem depends on that success; 3. That the solution is the great end and object of geometry. The same three notions are equally prevalent among the same class in England. No reward has ever been offered by the government of either country. The longitude problem in no way depends upon perfect solution; existing approximations are sufficient to a point of accuracy far beyond what can be wanted. And geometry, content with what exists, has long pressed on to other matters. Sometimes a cyclometer persuades a skipper, who has made land in the wrong place, that the astronomers are in fault for using a wrong measure of the circle; and the skipper thinks it a very comfortable solution! And this is the utmost that the problem ever has to do with longitude."

In the year 1775 the Royal Academy of Sciences of Paris passed a resolution not to entertain communications which claimed to give solutions of any of the following problems: The duplication of the cube, the trisection of an angle, the quadrature of a circle, or any machine announced as showing perpetual motion. And we have heard that the Royal Society of London passed similar resolutions, but of course in the case of neither society did these resolutions exclude legitimate mathematical investigations—the famous computations of Mr. Shanks, to which we shall have occasion to refer hereafter, were submitted to the Royal Society of London and published in their Transactions. Attempts to "square the circle," when made intelligently, were not only commendable but have been productive of the most valuable results. At the same time there is no problem, with the possible exception of that of perpetual motion, that has caused more waste of time and effort on the part of those who have attempted its solution, and who have in almost all cases been ignorant both of the nature of the problem and of the results which have been already attained. From Archimedes down to the present time some of the ablest mathematicians have occupied themselves with the quadrature, or, as it is called in common language, "the squaring of the circle"; but these men are not to be placed in the same class with those to whom the term "circle-squarers" is generally applied.

[11]

As already noted, the great difficulty with most circle-squarers is that they are ignorant both of the nature of the problem to be solved and of the results which have been already attained. Sometimes we see it explained as the drawing of a square inside a circle and at other times as the drawing of a square around a circle, but both these problems are amongst the very simplest in practical geometry, the solutions being given in the sixth and seventh propositions of the Fourth Book of Euclid. Other definitions have been given, some of them quite absurd. Thus in France, in 1753, M. de Causans, of the Guards, cut a circular piece of turf, squared it, and from the result deduced original sin and the Trinity. He found out that the circle was equal to the square in which it is inscribed, and he offered a reward for the detection of any error, and actually deposited 10,000 francs as earnest of 300,000. But the courts would not allow any one to recover.

[12]

In the last number of the Athenæum for 1855 a correspondent says "the thing is no longer a *problem* but an *axiom*." He makes the square equal to a circle by making each side equal to a quarter of the circumference. As De Morgan says, he does not know that the area of the circle is greater than that of any other figure of the same circuit.

Such ideas are evidently akin to the poetic notion of the quadrature. Aristophanes, in the "Birds," introduces a geometer, who announces his intention to make a *square circle*. And Pope in the "Dunciad" delivers himself as follows:

Mad Mathesis alone was unconfined,  
Too mad for mere material chains to  
bind,—  
Now to pure space lifts her ecstatic  
stare,  
Now, running round the circle, finds it  
square.

The author's note explains that this "regards the wild and fruitless attempts of squaring the circle." The poetic idea seems to be that the geometers try to make a square circle.

As stated by all recognized authorities, the problem is this: To describe a square which shall be exactly equal in area to a given circle.

The solution of this problem may be given in two ways: (1) the arithmetical method, by which the area of a circle is found and expressed numerically in square measure, and (2) the geometrical quadrature, by which a square, equal in area to a given circle, is described by means of rule and compasses alone.

Of course, if we know the area of the circle, it is easy to find the side of a square of equal area; this can be done by simply extracting the square root of the area, provided the number is one of which it is possible to extract the square root. Thus, if we have a circle which contains 100 square feet, a square with sides of 10 feet would be exactly equal to it. But the ascertaining of the area of the circle is the very point where the difficulty comes in; the dimensions of circles are usually stated in the lengths of the diameters, and when this is the case, the problem resolves itself into another, which is: To find the area of a circle when the diameter is given. [13]

Now Archimedes proved that the area of any circle is equal to that of a triangle whose base has the same length as the circumference and whose altitude or height is equal to the radius. Therefore if we can find the length of the circumference when the diameter is given, we are in possession of all the points needed to enable us to "square the circle."

In this form the problem is known to mathematicians as that of the rectification of the curve.

In a practical form this problem must have presented itself to intelligent workmen at a very early stage in the progress of operative mechanics. Architects, builders, blacksmiths, and the makers of chariot wheels and vessels of various kinds must have had occasion to compare the diameters and circumferences of round articles. Thus in I Kings, vii, 23, it is said of Hiram of Tyre that "he made a molten sea, ten cubits from the one brim to the other; it was round all about \* \* \* and a line of thirty cubits did compass it round about," from which it has been inferred that among the Jews, at that time, the accepted ratio was 3 to 1, and perhaps, with the crude measuring instruments of that age, this was as near as could be expected. And this ratio seems to have been accepted by the Babylonians, the Chinese, and probably also by the Greeks, in the earliest times. At the same time we must not forget that these statements in regard to the ratio come to us through historians and prophets, and may not have been the figures used by trained mechanics. An error of one foot in a hoop made to go round a tub or cistern of seven feet in diameter, would hardly be tolerated even in an apprentice. [14]

The Egyptians seem to have reached a closer approximation, for from a calculation in the Rhind papyrus, the ratio of 3.16 to 1 seems to have been at one time in use. It is probable, however, that in these early times the ratio accepted by mechanics in general was determined by actual measurement, and this, as we shall see hereafter, is quite capable of giving results accurate to the second fractional place, even with very common apparatus.

To Archimedes, however, is generally accorded the credit of the first attempt to solve the problem in a scientific manner; he took the circumference of the circle as intermediate between the perimeters of the inscribed and the circumscribed polygons, and reached the conclusion that the ratio lay between  $3\frac{1}{7}$  and  $3\frac{10}{71}$ , or between 3.1428 and 3.1408.

This ratio, in its more accurate form of 3.141592.. is now known by the Greek letter  $\pi$  (pronounced like the common word *pie*), a symbol which was introduced by Euler, between 1737 and 1748, and which is now adopted all over the world. I have, however, used the term ratio, or value of the ratio instead, throughout this chapter, as probably being more familiar to my readers.

Professor Muir justly says of this achievement of Archimedes, that it is "a most notable piece of work; the immature condition of arithmetic, at the time, was the only real obstacle preventing the evaluation of the ratio to any degree of accuracy whatever." [15]

And when we remember that neither the numerals now in use nor the Arabic numerals, as they are usually called, nor any system equivalent to our decimal system, was known to these early mathematicians, such a calculation as that made by Archimedes was a wonderful feat.

If any of my readers, who are familiar with the Hebrew or Greek numbers, and the mode of representing them by letters, will try to do any of those more elaborate sums which, when

worked out by modern methods, are mere child's play in the hands of any of the bright scholars in our common schools, they will fully appreciate the difficulties under which Archimedes labored.

Or, if ignorant of Greek and Hebrew, let them try it with the Roman numerals, and multiply XCVIII by MDLVII, without using Arabic or common numerals. Professor McArthur, in his article on "Arithmetic" in the Encyclopædia Britannica, makes the following statement on this point:

"The methods that preceded the adoption of the Arabic numerals were all comparatively unwieldy, and very simple processes involved great labor. The notation of the Romans, in particular, could adapt itself so ill to arithmetical operations, that nearly all their calculations had to be made by the abacus. One of the best and most manageable of the ancient systems is the Greek, though that, too, is very clumsy."

After Archimedes, the most notable result was that given by Ptolemy, in the "Great Syntaxis." He made the ratio 3.141552, which was a very close approximation.

For several centuries there was little progress towards a more accurate determination of the ratio. Among the Hindoos, as early as the sixth century, the now well-known value, 3.1416, had been obtained by Arya-Bhata, and a little later another of their mathematicians came to the conclusion that the square root of 10 was the true value of the ratio. He was led to this by calculating the perimeters of the successive inscribed polygons of 12, 24, 48, and 96 sides, and finding that the greater the number of sides the nearer the perimeter of the polygon approached the square root of 10. He therefore thought that the perimeter or circumference of the circle itself would be the square root of exactly 10. It is too great, however, being 3.1622 instead of 3.14159... The same idea is attributed to Bovillus, by Montucla.

[16]

By calculating the perimeters of the inscribed and circumscribed polygons, Vieta (1579) carried his approximation to ten fractional places, and in 1585 Peter Metius, the father of Adrian, by a lucky step reached the now famous fraction  $355/113$ , or 3.14159292, which is correct to the sixth fractional place. The error does not exceed one part in thirteen millions.

At the beginning of the seventeenth century, Ludolph Van Ceulen reached 35 places. This result, which "in his life he found by much labor," was engraved upon his tombstone in St. Peter's Church, Leyden. The monument has now unfortunately disappeared.

From this time on, various mathematicians succeeded, by improved methods, in increasing the approximation. Thus in 1705, Abraham Sharp carried it to 72 places; Machin (1706) to 100 places; Rutherford (1841) to 208 places, and Mr. Shanks in 1853, to 607 places. The same computer in 1873 reached the enormous number of 707 places.

[17]

Printed in type of the same size as that used on this page, these figures would form a line nearly six feet long.

As a matter of interest I give here the value of the ratio of the circumference to the diameter, to 127 places:

3.14159 26535 89793 23846 26433 83279  
50288 41971  
69399 37510 58209 74944 59230 78164  
06286 20899  
86280 34825 34211 70679 82148 08651  
32723 06647  
09384 46+

The degree of accuracy which may be attained by using a ratio carried to only ten fractional places, far exceeds anything that can be required in even the finest work, and indeed it is beyond anything attainable by means of our present tools and instruments. For example: If the length of a curve of 100 feet radius were determined by a value of ten fractional places, the result would not err by the one-millionth part of an inch, a quantity which is quite invisible under the best microscopes of the present day. This shows us that in any calculations relating to the dimensions of the earth, such as longitude, etc., we have at our command, in the 127 places of figures given above, an exactness which for all practical purposes may be regarded as absolute. This will be best appreciated by a consideration of the fact that if the earth were a perfect sphere and if we knew its exact diameter, we could calculate so exactly the length of an iron hoop which would go round it, that the difference produced by a change of temperature equal to the millionth of a millionth part of a degree Fahrenheit, would far exceed the error arising from the difference between the true ratio and the result thus reached.

Such minute quantities are far beyond the powers of conception of even the most thoroughly trained human mind, but when we come to use six and seven hundred places the results are simply astounding. Professor De Morgan, in his "Budget of Paradoxes," gives the following illustration of the extreme accuracy which might be attained by the use of 607 fractional places, the highest number which had been reached when he wrote:

[18]

"Say that the blood-globule of one of our animalcules is a millionth of an inch in diameter.<sup>[1]</sup> Fashion in thought a globe like our own, but so much larger that our globe is but a blood-globule in one of its animalcules; never mind the microscope which shows the creature being rather a bulky instrument. Call this the first globule above us. Let the first globe above us be but a blood-globule, as to size, in the animalcule of a still larger



globe, which call the second globe above us. Go on in this way to the twentieth globe above us. Now, go down just as far on the other side. Let the blood-globule with which we started be a globe peopled with animals like ours, but rather smaller, and call this the first globe below us. This is a fine stretch of progression both ways. Now, give the giant of the twentieth globe above us the 607 decimal places, and, when he has measured the diameter of his globe with accuracy worthy of his size, let him calculate the circumference of his equator from the 607 places. Bring the little philosopher from the twentieth globe below us with his very best microscope, and set him to see the small error which the giant must make. He will not succeed, unless his microscopes be much better for his size than ours are for ours."

[19]

It would of course be impossible for any human mind to grasp the range of such an illustration as that just given. At the same time these illustrations do serve in some measure to give us an impression, if not an idea, of the vastness on the one hand and the minuteness on the other of the measurements with which we are dealing. I therefore offer no apology for giving another example of the nearness to absolute accuracy with which the circle has been "squared."

It is common knowledge that light travels with a velocity of about 185,000 miles per second. In other words, light would go completely round the earth in a little more than one-eighth of a second, or, as Herschel puts it, in less time than it would take a swift runner to make a single stride. Taking this distance of 185,000 miles per second as our unit of measurement, let us apply it as follows:

It is generally believed that our solar system is but an individual unit in a stellar system which may include hundreds of thousands of suns like our own, with all their attendant planets and moons. This stellar system again may be to some higher system what our solar system is to our own stellar system, and there may be several such gradations of systems, all going to form one complete whole which, for want of a better name, I shall call a universe. Now this universe, complete in itself, may be finite and separated from all other systems of a similar kind by an empty space, across which even gravitation cannot exert its influence. Let us suppose that the imaginary boundary of this great universe is a perfect circle, the extent of which is such that light, traveling at the rate we have named (185,000 miles per second), would take millions of millions of years to pass across it, and let us further suppose that we know the diameter of this mighty space with perfect accuracy; then, using Mr. Shanks' 707 places of decimal fractions, we could calculate the circumference to such a degree of accuracy that the error would not be visible under any microscope now made.

[20]

An illustration which may impress some minds even more forcibly than either of those which we have just given, is as follows:

Let us suppose that in some titanic iron-works a steel armor-plate had been forged, perfectly circular in shape and having a diameter of exactly 185,000,000 miles, or very nearly that of the orbit of the earth, and a thickness of 8000 miles, or about that of the diameter of the earth. Let us further assume that, owing to the attraction of some immense stellar body, this huge mass has what we would call a weight corresponding to that which a plate of the same material would have at the surface of the earth, and let it be required to calculate the length of the side of a square plate of the same material and thickness and which shall be exactly equal to the circular plate.

Using the 707 places of figures of Mr. Shanks, the length of the required side could be calculated so accurately that the difference in weight between the two plates (the circle and the square) would not be sufficient to turn the scale of the most delicate chemical balance ever constructed.

Of course in assuming the necessary conditions, we are obliged to leave out of consideration all those more refined details which would embarrass us in similar calculations on the small scale and confine ourselves to the purely mathematical aspect of the case; but the stretch of imagination required is not greater than that demanded by many illustrations of the kind.

[21]

So much, then, for what is claimed by the mathematicians; and the certainty that their results are correct, as far as they go, is shown by the predictions made by astronomers in regard to the moon's place in the heavens at any given time. The error is less than a second of time in twenty-seven days, and upon this the sailor depends for a knowledge of his position upon the trackless deep. This is a practical test upon which merchants are willing to stake, and do stake, billions of dollars every day.

It is now well established that, like the diagonal and side of a square, the diameter and circumference of any circle are incommensurable quantities. But, as De Morgan says, "most of the quadrators are not aware that it has been fully demonstrated that no two numbers whatsoever can represent the ratio of the diameter to the circumference, with perfect accuracy. When, therefore, we are told that either 8 to 25 or 64 to 201 is the true ratio, we know that it is no such thing, without the necessity of examination. The point that is left open, as not fully demonstrated to be impossible, is the *geometrical* quadrature, the determination of the circumference by the straight line and circle, used as in Euclid."

But since De Morgan wrote, it has been shown that a Euclidean construction is actually impossible. Those who desire to examine the question more fully, will find a very clear discussion of the subject in Klein's "Famous Problems in Elementary Geometry." (Boston, Ginn & Co.)

There are various geometrical constructions which give approximate results that are

[22]

sufficiently accurate for most practical purposes. One of the oldest of these makes the ratio  $3\frac{1}{7}$  to 1. Using this ratio we can ascertain the circumference of a circle of which the diameter is given by the following method: Divide the diameter into 7 equal parts by the usual method. Then, having drawn a straight line, set off on it three times the diameter and one of the sevenths; the result will give the circumference with an error of less than the one twenty-five-hundredth part or one twenty-fifth of one per cent.

If the circumference had been given, the diameter might have been found by dividing the circumference into twenty-two parts and setting off seven of them. This would give the diameter. A more accurate method is as follows:

Given a circle, of which it is desired to find the length of the circumference: Inscribe in the given circle a square, and to three times the diameter of the circle add a fifth of the side of the square; the result will differ from the circumference of the circle by less than one-seventeen-thousandth part of it. Another method which gives a result accurate to the one-seventeen-thousandth part is as follows:

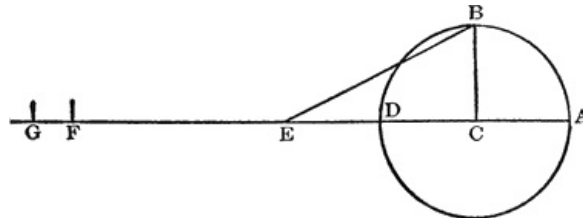

Fig. 1.

Let AD, Fig. 1, be the diameter of the circle, C the center, and CB the radius perpendicular to AD. Continue AD and make DE equal to the radius; then draw BE, and in AE, continued, make EF equal to it; if to this line EF, its fifth part FG be added, the whole line AG will be equal to the circumference described with the radius CA, within one-seventeen-thousandth part.

[23]

The following construction gives even still closer results: Given the semi-circle ABC, Fig. 2; from the extremities A and C of its diameter raise two perpendiculars, one of them CE, equal to the tangent of  $30^\circ$ , and the other AF, equal to three times the radius. If the line FE be then drawn, it will be equal to the semi-circumference of the circle, within one-hundred-thousandth part nearly. This is an error of one-thousandth of one per cent, an accuracy far greater than any mechanic can attain with the tools now in use.

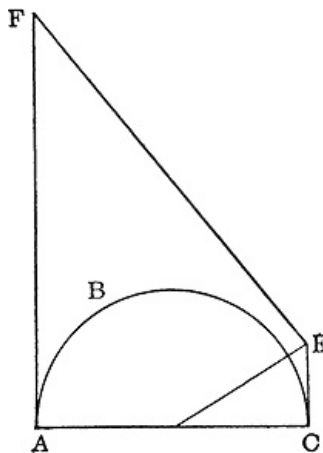

Fig. 2.

When we have the length of the circumference and the length of the diameter, we can describe a square which shall be equal to the area of the circle. The following is the method:

[24]

Draw a line ACB, Fig. 3, equal to half the circumference and half the diameter together. Bisect this line in O, and with O as a center and AO as radius, describe the semi-circle ADB. Erect a perpendicular CD, at C, cutting the arc in D; CD is the side of the required square which can then be constructed in the usual manner. The explanation of this is that CD is a mean proportional between AC and CB.

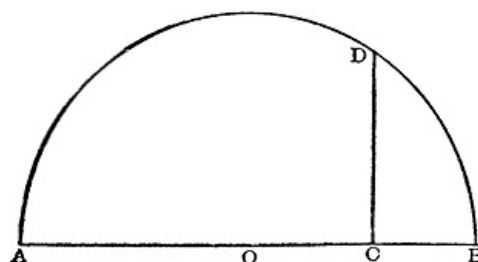

Fig. 3.

De Morgan says: "The following method of finding the circumference of a circle (taken from a

paper by Mr. S. Drach in the 'Philosophical Magazine,' January, 1863, Suppl.), is as accurate as the use of eight fractional places: From three diameters deduct eight-thousandths and seven-millionths of a diameter; to the result, add five per cent. We have then not quite enough; but the shortcoming is at the rate of about an inch and a sixtieth of an inch in 14,000 miles."

For obtaining the side of a square which shall be equal in area to a given circle, the empirical method, given by Ahmes in the Rhind papyrus 4000 years ago, is very simple and sufficiently accurate for many practical purposes. The rule is: Cut off one-ninth of the diameter and construct a square upon the remainder. [25]

This makes the ratio 3.16.. and the error does not exceed one-third of one per cent.

There are various mechanical methods of measuring and comparing the diameter and the circumference of a circle, and some of them give tolerably accurate results. The most obvious device and that which was probably the oldest, is the use of a cord or ribbon for the curved surface and the usual measuring rule for the diameter. With an accurately divided rule and a thin metallic ribbon which does not stretch, it is possible to determine the ratio to the second fractional place, and with a little care and skill the third place may be determined quite closely.

An improvement which was no doubt introduced at a very early day is the measuring wheel or circumferentor. This is used extensively at the present day by country wheelwrights for measuring tires. It consists of a wheel fixed in a frame so that it may be rolled along or over any surface of which the measurement is desired.

This may of course be used for measuring the circumference of any circle and comparing it with the diameter. De Morgan gives the following instance of its use: A squarer, having read that the circular ratio was undetermined, advertised in a country paper as follows: "I thought it very strange that so many great scholars in all ages should have failed in finding the true ratio and have been determined to try myself." He kept his method secret, expecting "to secure the benefit of the discovery," but it leaked out that he did it by rolling a twelve-inch disk along a straight rail, and his ratio was 64 to 201 or 3.140625 exactly. As De Morgan says, this is a very creditable piece of work; it is not wrong by 1 in 3000. [26]

Skilful machinists are able to measure to the one-five-thousandth of an inch; this, on a two-inch cylinder, would give the ratio correct to five places, provided we could measure the curved line as accurately as we can the straight diameter, but it is difficult to do this by the usual methods. Perhaps the most accurate plan would be to use a fine wire and wrap it round the cylinder a number of times, after which its length could be measured. The result would of course require correction for the angle which the wire would necessarily make if the ends did not meet squarely and also for the diameter of the wire. Very accurate results have been obtained by this method in measuring the diameters of small rods.

A somewhat original way of finding the area of a circle was adopted by one squarer. He took a carefully turned metal cylinder and having measured its length with great accuracy he adopted the Archimedean method of finding its cubical contents, that is to say, he immersed it in water and found out how much it displaced. He then had all the data required to enable him to calculate the area of the circle upon which the cylinder stood.

Since the straight diameter is easily measured with great accuracy, when he had the area he could readily have found the circumference by working backward the rule announced by Archimedes, viz.: that the area of a circle is equal to that of a triangle whose base has the same length as the circumference and whose altitude is equal to the radius.

One would almost fancy that amongst circle-squarers there prevails an idea that some kind of ban or magical prohibition has been laid upon this problem; that like the hidden treasures of the pirates of old it is protected from the attacks of ordinary mortals by some spirit or demoniac influence, which paralyses the mind of the would-be solver and frustrates his efforts. [27]

It is only on such an hypothesis that we can account for the wild attempts of so many men, and the persistence with which they cling to obviously erroneous results in the face not only of mathematical demonstration, but of practical mechanical measurements. For even when working in wood it is easy to measure to the half or even the one-fourth of the hundredth of an inch, and on a ten-inch circle this will bring the circumference to 3.1416 inches, which is a corroboration of the orthodox ratio (3.14159) sufficient to show that any value which is greater than 3.142 or less than 3.141 cannot possibly be correct.

And in regard to the area the proof is quite as simple. It is easy to cut out of sheet metal a circle 10 inches in diameter, and a square of 7.85 on the side, or even one-thousandth of an inch closer to the standard 7.854. Now if the work be done with anything like the accuracy with which good machinists work, it will be found that the circle and the square will exactly balance each other in weight, thus proving in another way the correctness of the accepted ratio.

But although even as early as before the end of the eighteenth century, the value of the ratio had been accurately determined to 152 places of decimals, the nineteenth century abounded in circle-squarers who brought forward the most absurd arguments in favor of other values. In 1836, a French well-sinker named Lacomme, applied to a professor of mathematics for information in regard to the amount of stone required to pave the circular bottom of a well, and was told that it was impossible "to give a correct answer, because the exact ratio of the diameter of a circle to its circumference had never been determined"! This absolutely true but very [28]

unpractical statement by the professor, set the well-sinker to thinking; he studied mathematics after a fashion, and announced that he had discovered that the circumference was exactly  $3\frac{1}{8}$  times the length of the diameter! For this discovery (?) he was honored by several medals of the first class, bestowed by Parisian societies.

Even as late as the year 1860, a Mr. James Smith of Liverpool, took up this ratio  $3\frac{1}{8}$  to 1, and published several books and pamphlets in which he tried to argue for its accuracy. He even sought to bring it before the British Association for the Advancement of Science. Professors De Morgan and Whewell, and even the famous mathematician, Sir William Rowan Hamilton, tried to convince him of his error, but without success. Professor Whewell's demonstration is so neat and so simple that I make no apology for giving it here. It is in the form of a letter to Mr. Smith: "You may do this: calculate the side of a polygon of 24 sides inscribed in a circle. I think you are mathematician enough to do this. You will find that if the radius of the circle be one, the side of the polygon is .264, etc. Now the arc which this side subtends is, according to your proposition,  $3.125\sqrt{12} = .2604$ , and, therefore, the chord is greater than its arc, which, you will allow, is impossible."

This must seem, even to a school-boy, to be unanswerable, but it did not faze Mr. Smith, and I doubt if even the method which I have suggested previously, viz., that of cutting a circle and a square out of the same piece of sheet metal and weighing them, would have done so. And yet by this method even a common pair of grocer's scales will show to any common-sense person the error of Mr. Smith's value and the correctness of the accepted ratio.

[29]

Even a still later instance is found in a writer who, in 1892, contended in the New York "Tribune" for 3.2 instead of 3.1416, as the value of the ratio. He announces it as the re-discovery of a long lost secret, which consists in the knowledge of a certain line called "the Nicomedean line." This announcement gave rise to considerable discussion, and even towards the dawn of the twentieth century 3.2 had its advocates as against the accepted ratio 3.1416.

Verily the slaves of the mighty wizard, Michael Scott, have not yet ceased from their labors!

#### FOOTNOTES:

- [1] What follows is an exceedingly forcible illustration of an important mathematical truth, but at the same time it may be worth noting that the size of the blood-globules or corpuscles has no relation to the size of the animal from which they are taken. The blood corpuscle of the tiny mouse is larger than that of the huge ox. The smallest blood corpuscle known is that of a species of small deer, and the largest is that of a lizard like reptile found in our southern waters—the amphiuma.

These facts do not at all affect the force or value of De Morgan's mathematical illustration, but I have thought it well to call the attention of the reader to this point, lest he should receive an erroneous physiological idea.

---

## II

[30]

### THE DUPLICATION OF THE CUBE



HIS problem became famous because of the halo of mythological romance with which it was surrounded. The story is as follows:

About the year 430 B.C. the Athenians were afflicted by a terrible plague, and as no ordinary means seemed to assuage its virulence, they sent a deputation of the citizens to consult the oracle of Apollo at Delos, in the hope that the god might show them how to get rid of it.

The answer was that the plague would cease when they had doubled the size of the altar of Apollo in the temple at Athens. This seemed quite an easy task; the altar was a cube, and they placed beside it another cube of exactly the same size. But this did not satisfy the conditions prescribed by the oracle, and the people were told that the altar must consist of one cube, the size of which must be exactly twice the size of the original altar. They then constructed a cubic altar of which the side or edge was twice that of the original, but they were told that the new altar was eight times and not twice the size of the original, and the god was so enraged that the plague became worse than before.

According to another legend, the reason given for the affliction was that the people had devoted themselves to pleasure and to sensual enjoyments and pursuits, and had neglected the study of philosophy, of which geometry is one of the higher departments—certainly a very sound reason, whatever we may think of the details of the story. The people then applied to the mathematicians, and it is supposed that their solution was sufficiently near the truth to satisfy

[31]

Apollo, who relented, and the plague disappeared.

In other words, the leading citizens probably applied themselves to the study of sewerage and hygienic conditions, and Apollo (the Sun) instead of causing disease by the festering corruption of the usual filth of cities, especially in the East, dried up the superfluous moisture, and promoted the health of the inhabitants.

It is well known that the relation of the area and the cubical contents of any figure to the linear dimensions of that figure are not so generally understood as we should expect in these days when the schoolmaster is supposed to be "abroad in the land." At an examination of candidates for the position of fireman in one of our cities, several of the applicants made the mistake of supposing that a two-inch pipe and a five-inch pipe were equal to a seven-inch pipe, whereas the combined capacities of the two small pipes are to the capacity of the large one as 29 to 49.

This reminds us of a story which Sir Frederick Bramwell, the engineer, used to tell of a water company using water from a stream flowing through a pipe of a certain diameter. The company required more water, and after certain negotiations with the owner of the stream, offered double the sum if they were allowed a supply through a pipe of double the diameter of the one then in use. This was accepted by the owner, who evidently was not aware of the fact that a pipe of double the diameter would carry *four* times the supply.

A square whose side is twice the length of another, and a circle whose diameter is twice that of another will each have an area four times that of the original. And in the case of solids: A ball of twice the diameter will weigh eight times as much as the original, and a ball of three times the diameter will weigh twenty-seven times as much as the original.

[32]

In attempting to calculate the side of a cube which shall have twice the volume of a given cube, we meet the old difficulty of incommensurability, and the solution cannot be effected geometrically, as it requires the construction of two mean proportionals between two given lines.

---

### III

[33]

## THE TRISECTION OF AN ANGLE



HIS problem is not so generally known as that of squaring the circle, and consequently it has not received so much attention from amateur mathematicians, though even within little more than a year a small book, in which an attempted solution is given, has been published. When it is first presented to an uneducated reader, whose mind has a mathematical turn, and especially to a skilful mechanic, who has not studied theoretical geometry, it is apt to create a smile, because at first sight most persons are impressed with an idea of its simplicity, and the ease with which it may be solved. And this is true, even of many persons who have had a fair general education. Those who have studied only what is known as "practical geometry" think at once of the ease and accuracy with which a right angle, for example, may be divided into three equal parts. Thus taking the right angle  $ACB$ , Fig. 4, which may be set off more easily and accurately than any other angle except, perhaps, that of  $60^\circ$ , and knowing that it contains  $90^\circ$ , describe an arc  $ADEB$ , with  $C$  for the center and any convenient radius. Now every school-boy who has played with a pair of compasses knows that the radius of a circle will "step" round the circumference exactly six times; it will therefore divide the  $360^\circ$  into six equal parts of  $60^\circ$  each. This being the case, with the radius  $CB$ , and  $B$  for a center, describe a short arc crossing the arc  $ADEB$  in  $D$ , and join  $CD$ . The angle  $DCB$  will be  $60^\circ$ , and as the angle  $ACB$  is  $90^\circ$ , the angle  $ACD$  must be  $30^\circ$ , or one-third part of the whole. In the same way lay off the angle  $ACE$  of  $60^\circ$ , and  $ECB$  must be  $30^\circ$ , and the remainder  $DCE$  must also be  $30^\circ$ . The angle  $ACB$  is therefore easily divided into three equal parts, or in other words, it is trisected. And with a slight modification of the method, the same may be done with an angle of  $45^\circ$ , and with some others. These however are only special cases, and the very essence of a geometrical solution of any problem is that it shall be applicable to *all* cases so that we require a method by which *any* angle may be divided into three equal parts by a pure Euclidean construction. The ablest mathematicians declare that the problem cannot be solved by such means, and De Morgan gives the following reasons for this conclusion: "The trisector of an angle, if he demand attention from any mathematician, is bound to produce from his construction, an expression for the sine or cosine of the third part of any angle, in terms of the sine or cosine of the angle itself, obtained by the help of no higher than the square root. The mathematician knows that such a thing cannot be; but the trisector virtually says it can be, and is bound to produce it to save time. This is the misfortune of most of the solvers of the celebrated problems, that they have not knowledge enough to present those consequences of their results by which they can be easily judged."

[34]

[35]

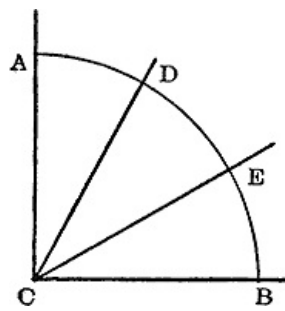

Fig. 4.

De Morgan gives an account of a "terrific" construction by a friend of Dr. Wallich, which he says is "so nearly true, that unless the angle be very obtuse, common drawing, applied to the construction, will not detect the error." But geometry requires *absolute* accuracy, not a mere approximation.

## IV

[36]

### PERPETUAL MOTION



It is probable that more time, effort, and money have been wasted in the search for a perpetual-motion machine than have been devoted to attempts to square the circle or even to find the philosopher's stone. And while it has been claimed in favor of this delusion that the pursuit of it has given rise to valuable discoveries in mechanics and physics, some even going so far as to urge that we owe the discovery of the great law of the conservation of energy to the suggestions made by the perpetual-motion seekers, we certainly have no evidence to show anything of the kind. Perpetual motion was declared to be an impossibility upon purely mechanical and mathematical grounds long before the law of the conservation of energy was thought of, and it is very certain that this delusion had no place in the thoughts of Rumford, Black, Davy, Young, Joule, Grove, and others when they devoted their attention to the laws governing the transformation of energy. Those who pursued such a will-o'-the-wisp, were not the men to point the way to any scientific discovery.

The search for a perpetual-motion machine seems to be of comparatively modern origin; we have no record of the labors of ancient inventors in this direction, but this may be as much because the records have been lost, as because attempts were never made. The works of a mechanical inventor rarely attracted much attention in ancient times, while the mathematical problems were regarded as amongst the highest branches of philosophy, and the search for the philosopher's stone and the elixir of life appealed alike to priest and layman. We have records of attempts made 4000 years ago to square the circle, and the history of the philosopher's stone is lost in the mists of antiquity; but it is not until the eleventh or twelfth century that we find any reference to perpetual motion, and it was not until the close of the sixteenth and the beginning of the seventeenth century that this problem found a prominent place in the writings of the day.

[37]

By perpetual motion is meant a machine which, without assistance from any external source except gravity, shall continue to go on moving until the parts of which it is made are worn out. Some insist that in order to be properly entitled to the name of a perpetual-motion machine, it must evolve more power than that which is merely required to run it, and it is true that almost all those who have attempted to solve this problem have avowed this to be their object, many going so far as to claim for their contrivances the ability to supply unlimited power at no cost whatever, except the interest on a small investment, and the trifling amount of oil required for lubrication. But it is evident that a machine which would of itself maintain a regular and constant motion would be of great value, even if it did nothing more than move itself. And this seems to have been the idea upon which those men worked, who had in view the supposed reward offered for such an invention as a means for finding the longitude. And it is well known that it was the hope of attaining such a reward that spurred on very many of those who devoted their time and substance to the subject.

[38]

There are several legitimate and successful methods of obtaining a practically perpetual motion, provided we are allowed to call to our aid some one of the various natural sources of power. For example, there are numerous mountain streams which have never been known to fail, and which by means of the simplest kind of a water-wheel would give constant motion to any light machinery. Even the wind, the emblem of fickleness and inconstancy, may be harnessed so that it will furnish power, and it does not require very much mechanical ingenuity to provide means whereby the surplus power of a strong gale may be stored up and kept in reserve for a time of calm. Indeed this has frequently been done by the raising of weights, the winding up of springs, the pumping of water into storage reservoirs and other simple contrivances.

The variations which are constantly occurring in the temperature and the pressure of the

atmosphere have also been forced into this service. A clock which required no winding was exhibited in London towards the latter part of the eighteenth century. It was called a perpetual motion, and the working power was derived from variations in the quantity, and consequently in the weight of the mercury, which was forced up into a glass tube closed at the upper end and having the lower end immersed in a cistern of mercury after the manner of a barometer. It was fully described by James Ferguson, whose lectures on Mechanics and Natural Philosophy were edited by Sir David Brewster. It ran for years without requiring winding, and is said to have kept very good time. A similar contrivance was employed in a clock which was possessed by the Academy of Painting at Paris. It is described in Ozanam's work, Vol. II, page 105, of the edition of 1803.

[39]

The changes which are constantly taking place in the temperature of all bodies, and the expansion and contraction which these variations produce, afford a very efficient power for clocks and small machines. Professor W. W. R. Ball tells us that "there was at Paris in the latter half of last century a clock which was an ingenious illustration of such perpetual motion. The energy, which was stored up in it to maintain the motion of the pendulum, was provided by the expansion of a silver rod. This expansion was caused by the daily rise of temperature, and by means of a train of levers it wound up the clock. There was a disconnecting apparatus, so that the contraction due to a fall of temperature produced no effect, and there was a similar arrangement to prevent overwinding. I believe that a rise of eight or nine degrees Fahrenheit was sufficient to wind up the clock for twenty-four hours."

Another indirect method of winding a watch is thus described by Professor Ball:

"I have in my possession a watch, known as the Lohr patent, which produces the same effect by somewhat different means. Inside the case is a steel weight, and if the watch is carried in a pocket this weight rises and falls at every step one takes, somewhat after the manner of a pedometer. The weight is moved up by the action of the person who has it in his pocket, and in falling the weight winds up the spring of the watch. On the face is a small dial showing the number of hours for which the watch is wound up. As soon as the hand of this dial points to fifty-six hours, the train of levers which wind up the watch disconnects automatically, so as to prevent overwinding the spring, and it reconnects again as soon as the watch has run down eight hours. The watch is an excellent time-keeper, and a walk of about a couple of miles is sufficient to wind it up for twenty-four hours."

Dr. Hooper, in his "Rational Recreations," has described a method of driving a clock by the motion of the tides, and it would not be difficult to contrive a very simple arrangement which would obtain from that source much more power than is required for that purpose. Indeed the probability is that many persons now living will see the time when all our railroads, factories, and lighting plants will be operated by the tides of the ocean. It is only a question of return for capital, and it is well known that that has been falling steadily for years. When the interest on investments falls to a point sufficiently low, the tides will be harnessed and the greater part of the heat, light, and power that we require will be obtained from the immense amount of energy that now goes to waste along our coasts.

[40]

Another contrivance by which a seemingly perpetual motion may be obtained is the dry pile or column of De Luc. The pile consists of a series of disks of gilt and silvered paper placed back to back and alternating, all the gilt sides facing one way and all the silver sides the other. The so-called gilding is really Dutch metal or copper, and the silver is tin or zinc, so that the two actually form a voltaic couple. Sometimes the paper is slightly moistened with a weak solution of molasses to insure a certain degree of dampness; this increases the action, for if the paper be artificially dried and kept in a perfectly dry atmosphere, the apparatus will not work. A pair of these piles, each containing two or three thousand disks the size of a quarter of a dollar, may be arranged side by side, vertically, and two or three inches apart. At the lower ends they are connected by a brass plate, and the upper ends are each surmounted by a small metal bell and between these bells a gilt ball, suspended by a silk thread, keeps vibrating perpetually. Many years ago I made a pair of these columns which kept a ball in motion for nearly two years, and Professor Silliman tells us that "a set of these bells rang in Yale College laboratory for six or eight years unceasingly." How much longer the columns would have continued to furnish energy sufficient to cause the balls to vibrate, it might be difficult to determine. The amount of energy required is exceedingly small, but since the columns are really nothing but a voltaic pile, it is very evident that after a time they would become exhausted.

[41]

Such a pair of columns, covered with a tall glass shade, form a very interesting piece of bric-a-brac, especially if the bells have a sweet tone, but the contrivance is of no practical use except as embodied in Bohnenberger's electroscope.

Inventions of this kind might be multiplied indefinitely, but none of these devices can be called a perpetual motion because they all depend for their action upon energy derived from external sources other than gravity. But the authors of these inventions are not to be classed with the regular perpetual-motion-mongers. The purposes for which these arrangements were invented were legitimate, and the contrivances answered fully the ends for which they were intended. The real perpetual-motion-seekers are men of a different stamp, and their schemes readily fall into one of these three classes: 1. ABSURDITIES, 2. FALLACIES, 3. FRAUDS. The following is a description of the most characteristic machines and apparatus of which accounts have been published.

[42]

# 1. ABSURDITIES

In this class may be included those inventions which have been made or suggested by honest but ignorant persons in direct violation of the fundamental principles of mechanics and physics. Such inventions if presented to any expert mechanic or student of science, would be at once condemned as impracticable, but as a general rule, the inventors of these absurd contrivances have been so confident of success, that they have published descriptions and sketches of them, and even gone so far as to take out patents before they have tested their inventions by constructing a working machine. It is said, that at one time the United States Patent Office issued a circular refusal to all applicants for patents of this kind, but at present instead of sending such a circular, the applicant is quietly requested to furnish a *working* model of his invention and that usually ends the matter. While I have no direct information on the subject, I suspect that the circular was withdrawn because of the amount of useless correspondence, in the shape of foolish replies and arguments, which it drew forth. To require a working model is a reasonable request and one for which the law duly provides, and when a successful model is forthcoming, a patent will no doubt be granted; but until that is presented the officials of the Patent Office can have no positive information in regard to the practicability of the invention.

The earliest mechanical device intended to produce perpetual motion is that known as the overbalancing wheel. This is described in a sketch book of the thirteenth century by Wilars de Honcourt, an architect of the period, and since then it has been re-invented hundreds of times. In its simplest forms it is thus described and figured by Ozanam:

[43]

"Fig. 5 represents a large wheel, the circumference of which is furnished, at equal distances, with levers, each bearing at its extremity a weight, and movable on a hinge so that in one direction they can rest upon the circumference, while on the opposite side, being carried away by the weight at the extremity, they are obliged to arrange themselves in the direction of the radius continued. This being supposed, it is evident that when the wheel turns in the direction ABC, the weights A, B, and C will recede from the center; consequently, as they act with more force, they will carry the wheel towards that side; and as a new lever will be thrown out, in proportion as the wheel revolves, it thence follows, say they, that the wheel will continue to move in the same direction. But notwithstanding the specious appearance of this reasoning, experience has proved that the machine will not go; and it may indeed be demonstrated that there is a certain position in which the center of gravity of all these weights is in the vertical plane passing through the point of suspension, and that therefore it must stop."



Fig. 5.



Fig. 6.

Another invention of a similar kind is thus described by the same author:

"In a cylindrical drum, in perfect equilibrium on its axis, are formed channels as seen in Fig. 6, which contain balls of lead or a certain quantity of quicksilver. In consequence of this disposition, the balls or quicksilver must, on the one side, ascend by approaching the center, and on the other must roll towards the circumference. The machine ought, therefore, to turn incessantly towards that side."

[44]

In his "Course of Lectures on Natural Philosophy," Dr. Thomas Young speaks of these contrivances as follows:

"One of the most common fallacies, by which the superficial projectors of machines for obtaining perpetual motion have been deluded, has arisen from imagining that any number of weights ascending by a certain path, on one side of the center of motion and descending on the other at a greater distance, must cause a constant preponderance on the side of the descent: for this purpose the weights have either been fixed on hinges, which allow them to fall over at a certain point, so as to become more distant from the center, or made to slide or roll along grooves or planes which lead them to a more remote part of the wheel, from whence they return as they ascend; but it will appear on the inspection of such a machine, that although some of the weights are more distant from the center than others, yet there is always a proportionately smaller number of them on that side on which they have the greatest power, so that these circumstances precisely counterbalance each other."

[45]



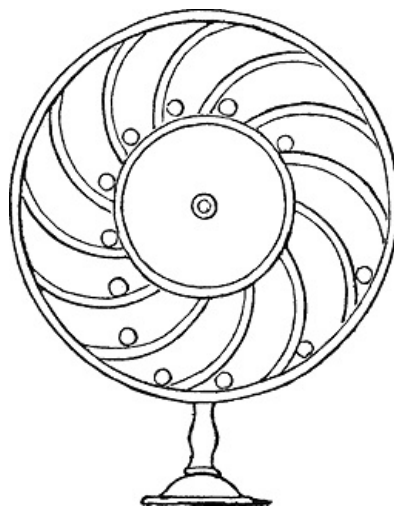

Fig. 7.

He then gives the illustration (Fig. 7), shown on the preceding page, of "a wheel supposed to be capable of producing a perpetual motion; the descending balls acting at a greater distance from the center, but being fewer in number than the ascending. In the model, the balls may be kept in their places by a plate of glass covering the wheel."

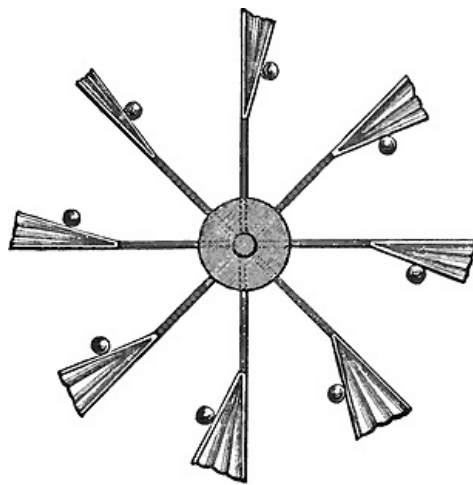

Fig. 8.

A more elaborate arrangement embodying the same idea is figured and described by Ozanam. The machine, which is shown in Fig. 8, consists of "a kind of wheel formed of six or eight arms, proceeding from a center where the axis of motion is placed. Each of these arms is furnished with a receptacle in the form of a pair of bellows: but those on the opposite arms stand in contrary directions, as seen in the figure. The movable top of each receptacle has affixed to it a weight, which shuts it in one situation and opens it in the other. In the last place, the bellows of the opposite arms have a communication by means of a canal, and one of them is filled with quicksilver." [46]

"These things being supposed, it is visible that the bellows on the one side must open, and those on the other must shut; consequently, the mercury will pass from the latter into the former, while the contrary will be the case on the opposite side."

Ozanam naïvely adds: "It might be difficult to point out the deficiency of this reasoning; but those acquainted with the true principles of mechanics will not hesitate to bet a hundred to one, that the machine, when constructed, will not answer the intended purpose."

That this bet would have been a perfectly safe one must be quite evident to any person who has the slightest knowledge of practical mechanics, and yet the fundamental idea which is embodied in this and the other examples which we have just given, forms the basis of almost all the attempts which have been made to produce a perpetual motion by purely mechanical means.

The hydrostatic paradox by which a few ounces of liquid may apparently balance many pounds, or even tons, has frequently suggested a form of apparatus designed to secure a perpetual motion. Dr. Arnott, in his "Elements of Physics," relates the following anecdote: "A projector thought that the vessel of his contrivance, represented here (Fig. 9), was to solve the renowned problem of the perpetual motion. It was goblet-shaped, lessening gradually towards the bottom until it became a tube, bent upwards at *c* and pointing with an open extremity into the goblet again. He reasoned thus: A pint of water in the goblet *a* must more than counterbalance an ounce which the tube *b* will contain, and must, therefore, be constantly pushing the ounce forward into the vessel again at *a*, and keeping up a stream or circulation, which will cease only when the water dries up. He was confounded when a trial showed him the same level in *a* and in *b*." [47]

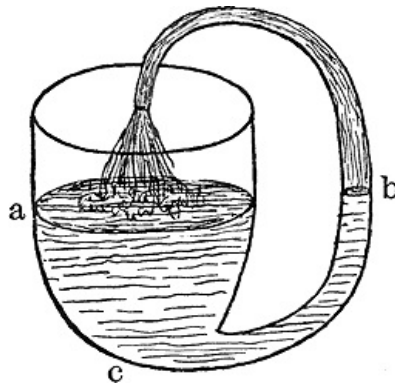

Fig. 9.

This suggestion has been adopted over and over again by sanguine inventors. Dircks, in his "Perpetuum Mobile," tells us that a contrivance, on precisely the same principle, was proposed by the Abbé de la Roque, in "Le Journal des Sçavans," Paris, 1686. The instrument was a U tube, one leg longer than the other and bent over, so that any liquid might drop into the top end of the short leg, which he proposed to be made of wax, and the long one of iron. Presuming the liquid to be more condensed in the metal than the wax tube, it would flow from the end into the wax tube and so continue.

[48]

This is a typical case. A man of learning and of high position is so confident that his theory is right that he does not think it worth while to test it experimentally, but rushes into print and immortalizes himself as the author of a blunder. It is safe to say that this absurd invention will do more to perpetuate his name than all his learning and real achievements. And there are others in the same predicament—circle-squarers who, a quarter of a century hence, will be remembered for their errors when all else connected with them will be forgotten.

To every miller whose mill ceased working for want of water, the idea has no doubt occurred that if he could only pump the water back again and use it a second or a third time he might be independent of dry or wet seasons. Of course no practical miller was ever so far deluded as to attempt to put such a suggestion into practice, but innumerable machines of this kind, and of the most crude arrangement, have been sketched and described in magazines and papers. Figures of wheels driving an ordinary pump, which returns to an elevated reservoir the water which has driven the wheel, are so common that it is not worth while to reproduce any of them. In the following attempt, however, which is copied from Bishop Wilkins' famous book, "Mathematical Magic" (1648), the well-known Archimedean screw is employed instead of a pump, and the naïveté of the good bishop's description and conclusion are well worth the space they will occupy.

After an elaborate description of the screw, he says: "These things, considered together, it will hence appear how a perpetual motion may seem easily contrivable. For, if there were but such a water-wheel made on this instrument, upon which the stream that is carried up may fall in its descent, it would turn the screw round, and by that means convey as much water up as is required to move it; so that the motion must needs be continual since the same weight which in its fall does turn the wheel, is, by the turning of the wheel, carried up again. Or, if the water, falling upon one wheel, would not be forcible enough for this effect, why then there might be two, or three, or more, according as the length and elevation of the instrument will admit; by which means the weight of it may be so multiplied in the fall that it shall be equivalent to twice or thrice that quantity of water which ascends; as may be more plainly discerned by the following diagram (Fig. 10):

[49]

"Where the figure LM at the bottom does represent a wooden cylinder with helical cavities cut in it, which at AB is supposed to be covered over with tin plates, and three waterwheels, upon it, HIK; the lower cistern, which contains the water, being CD. Now, this cylinder being turned round, all the water which from the cistern ascends through it, will fall into the vessel at E, and from that vessel being conveyed upon the water-wheel H, shall consequently give a circular motion to the whole screw. Or, if this alone should be too weak for the turning of it, then the same water which falls from the wheel H, being received into the other vessel F, may from thence again descend on the wheel I, by which means the force of it will be doubled. And if this be yet insufficient, then may the water, which falls on the second wheel I, be received into the other vessel G, and from thence again descend on the third wheel at K; and so for as many other wheels as the instrument is capable of. So that besides the greater distance of these three streams from the center or axis by which they are made so much heavier; and besides that the fall of this outward water is forcible and violent, whereas the ascent of that within is natural—besides all this, there is twice as much water to turn the screw as is carried up by it.

[50]

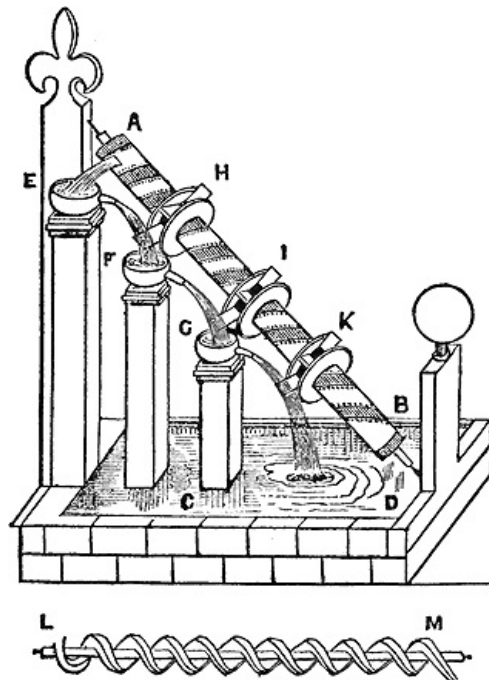

Fig. 10.

"But, on the other side, if all the water falling upon one wheel would be able to turn it round, then half of it would serve with two wheels, and the rest may be so disposed of in the fall as to serve unto some other useful, delightful ends.

[51]

"When I first thought of this invention, I could scarce forbear, with Archimedes, to cry out 'Eureka! Eureka!' it seeming so infallible a way for the effecting of a perpetual motion that nothing could be so much as probably objected against it; but, upon trial and experience, I find it altogether insufficient for any such purpose, and that for these two reasons:

- "1. The water that ascends will not make any considerable stream in the fall.
- "2. This stream, though multiplied, will not be of force enough to turn about the screw."

How well it would have been for many of those inventors, who supposed that they had discovered a successful perpetual motion, if they had only given their contrivances a fair and unprejudiced test as did the good old bishop!

A modification of this device, in which mercury is used instead of water, is thus described by a correspondent of "The Mechanic's Magazine." (London.)

"In Fig. 11, A is the screw turning on its two pivots GG; B is a cistern to be filled above the level of the lower aperture of the screw with mercury, which I conceive to be preferable to water on many accounts, and principally because it does not adhere or evaporate like water; C is a reservoir, which, when the screw is turned round, receives the mercury which falls from the top; there is a pipe, which, by the force of gravity, conveys the mercury from the reservoir C on to (what for want of a better term may be called) the float-board E, fixed at right angles to the center [axis] of the screw, and furnished at its circumference with ridges or floats to intercept the mercury, the moment and weight of which will cause the float-board and screw to revolve, until, by the proper inclination of the floats, the mercury falls into the receiver F, from whence it again falls by its spout into the cistern G, where the constant revolution of the screw takes it up again as before."

He then suggests some difficulties which the ball, seen just under the letter E, is intended to overcome, but he confesses that he has never tried it, and to any practical mechanic it is very obvious that the machine will not work. But we give the description in the language of the inventor, as a fair type of this class of perpetual-motion machines.

[52]

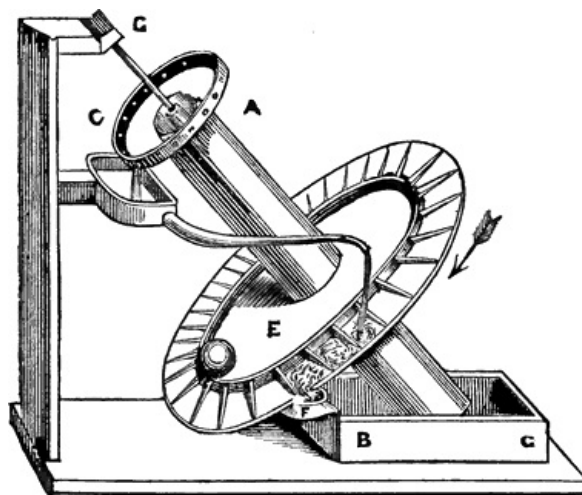

Fig. 11.

In the year 1790 a Doctor Schweirs took out a patent for a machine in which small metal balls were used instead of a liquid, and they were raised by a sort of chain pump which delivered them upon the circumference of a large wheel, which was thus caused to revolve. It was claimed for this invention that it kept going for some months, but any mechanic who will examine the Doctor's drawing must see that it could not have continued in motion after the initial impulse had been expended. [53]

That property of liquids known as capillary attraction has been frequently called to the aid of perpetual-motion seekers, and the fact that although water will, in capillary tubes and sponges, rise several inches above the general level, it will not overflow, has been a startling surprise to the would-be inventors. Perhaps the most notable instance of a mistake of this kind occurred in the case of the famous Sir William Congreve, the inventor of the military rockets that bore his name, and the author of certain improvements in matches which were called after him. It was thus described and figured in an article which appeared in the "Atlas" (London) and was copied into "The Mechanic's Magazine" (London) for 1827:

"The celebrated Boyle entertained an idea that perpetual motion might be obtained by means of capillary attraction; and, indeed, there seems but little doubt that nature has employed this force in many instances to produce this effect.

"There are many situations in which there is every reason to believe that the sources of springs on the tops and sides of mountains depend on the accumulation of water created at certain elevations by the operation of capillary attraction, acting in large masses of porous material, or through laminated substances. These masses being saturated, in process of time become the sources of springs and the heads of rivers; and thus by an endless round of ascending and descending waters, form, on the great scale of nature, an incessant cause of perpetual motion, in the purest acceptance of the term, and precisely on the principle that was contemplated by Boyle. It is probable, however, that any imitation of this process on the limited scale practicable by human art would not be of sufficient magnitude to be effective. Nature, by the immensity of her operations, is able to allow for a slowness of process which would baffle the attempts of man in any direct and simple imitation of her works. Working, therefore, upon the same causes, he finds himself obliged to take a more complicated mode to produce the same effect. [54]

"To amuse the hours of a long confinement from illness, Sir William Congreve has recently contrived a scheme of perpetual motion, founded on this principle of capillary attraction, which, it is apprehended, will not be subject to the general refutation applicable to those plans in which the power is supposed to be derived from gravity only. Sir William's perpetual motion is as follows:

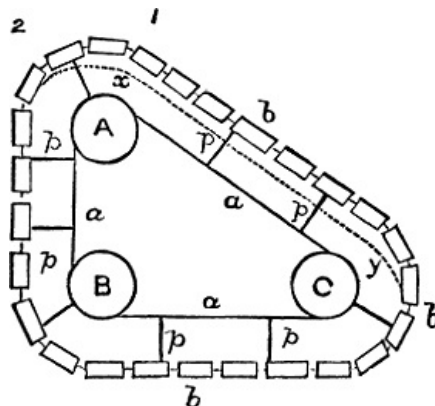

Fig. 12.

"Let ABC, Fig. 12, be three horizontal rollers fixed in a frame; aaa, etc., is an endless band of sponge, running round these rollers; and bbb, etc., is an endless chain of weights, surrounding the band of sponge, and attached to it, so that they must move together; every part of this band and chain being so accurately uniform in weight that the perpendicular side AB will, in all positions of the band and chain, be in equilibrium

with the hypotenuse AC, on the principle of the inclined plane. Now, if the frame in which these rollers are fixed be placed in a cistern of water, having its lower part immersed therein, so that the water's edge cuts the upper part of the rollers BC, then, if the weight and quantity of the endless chain be duly proportioned to the thickness and breadth of the band of sponge, the band and chain will, on the water in the cistern being brought to the proper level, begin to move round the rollers in the direction AB, by the force of capillary attraction, and will continue so to move. The process is as follows:

[55]

"On the side AB of the triangle, the weights bbb, etc., hanging perpendicularly alongside the band of sponge, the band is not compressed by them, and its pores being left open, the water at the point x, at which the band meets its surface, will rise to a certain height y, above its level, and thereby create a load, which load will not exist on the ascending side CA, because on this side the chain of weights compresses the band at the water's edge, and squeezes out any water that may have previously accumulated in it; so that the band rises in a dry state, the weight of the chain having been so proportioned to the breadth and thickness of the band as to be sufficient to produce this effect. The load, therefore, on the descending side AB, not being opposed by any similar load on the ascending side, and the equilibrium of the other parts not being disturbed by the alternate expansion and compression of the sponge, the band will begin to move in the direction AB; and as it moves downwards, the accumulation of water will continue to rise, and thereby carry on a constant motion, provided the load at xy be sufficient to overcome the friction on the rollers ABC.

"Now to ascertain the quantity of this load in any particular machine, it must be stated that it is found by experiment that the water will rise in a fine sponge about an inch above its level; if, therefore, the band and sponge be one foot thick and six feet broad, the area of its horizontal section in contact with the water would be 864 square inches, and the weight of the accumulation of water raised by the capillary attraction being one inch rise upon 864 square inches, would be 30 lb., which, it is conceived, would be much more than equivalent to the friction of the rollers."

The article, inspired no doubt by Sir William, then goes on to give elaborate reasons for the success of the device, but all these are met by the damning fact that the machine never worked. Some time afterwards Sir William, at considerable expense, published a pamphlet in which he explained and defended his views. If he had only had a working model made and the thing had continued in motion for a few hours, he would have silenced all objectors far more quickly and forcibly than he ever could have done by any amount of argument.

[56]

And in his case there could have been no excuse for his not making a small machine after the plans that he published and even patented. He was wealthy and could have commanded the services of the best mechanics in London, but no working model was ever made. Many inventors of perpetual-motion machines offer their poverty as an excuse for not making a model or working machine. Thus Dircks, in his "Perpetuum Mobile" gives an account of "a mechanic, a model maker, who had a neat brass model of a time-piece, in which were two steel balls A and B;—B to fall into a semicircular gallery C, and be carried to the end D of a straight trough DE; while A in its turn rolls to E, and so on continuously; only the gallery C not being screwed in its place, we are desired to take the will for the deed, until twenty shillings be raised to complete this part of the work!"

And Mr. Dircks also quotes from the "Builder" of June, 1847: "This vain delusion, if not still in force, is at least as standing a fallacy as ever. Joseph Hutt, a frame-work knitter, in the neighborhood of the enlightened town of Hinckley, professes to have discovered it [perpetual motion] and only wants twenty pounds, as usual, to set it agoing."

The following rather curious arrangement was described in "The Mechanic's Magazine" for 1825.

"I beg leave to offer the prefixed device. The point at which, like all the rest, it fails, I confess I did not (as I do now) plainly perceive at once, although it is certainly very obvious. The original idea was this—to enable a body which would float in a heavy medium and sink in a lighter one, to pass successively through the one to the other, the continuation of which would be the end in view. To say that valves cannot be made to act as proposed will not be to show the *rationale* (if I may so say) upon which the idea is fallacious."

[57]

The figure is supposed to be tubular, and made of glass, for the purpose of seeing the action of the balls inside, which float or fall as they travel from air through water and from water through air. The foot is supposed to be placed in water, but it would answer the same purpose if the bottom were closed.

DESCRIPTION OF THE ENGRAVING, FIG. 13. No. 1, the left leg, filled with water from B to A. 2 and 3, valves, having in their centers very small projecting valves; they all open upwards. 4, the right leg, containing air from A to F. 5 and 6, valves, having very small ones in their centers; they all open downwards. The whole apparatus is supposed to be air and water-tight. The round figures represent hollow balls, which will sink one-fourth of their bulk in water (of course will fall in air); the weight therefore of three balls resting upon one ball in water, as at E, will just bring its top even with the water's edge; the weight of four balls will sink it under the surface until the ball immediately over it is one-fourth its bulk in water, when the under ball will escape round the corner at C, and begin to ascend.

"The machine is supposed (in the figure) to be in action, and No. 8 (one of the balls) to have just escaped round the corner at C, and to be, by its buoyancy, rising up to valve No. 3, striking

first the small projecting valve in the center, which when opened, the large one will be raised by the buoyancy of the ball; because the moment the small valve in the center is opened (although only the size of a pin's head), No. 2 valve will have taken upon itself to sustain the whole column of water from A to B. The said ball (No. 8) having passed through the valve No. 3, will, by appropriate weights or springs, close; the ball will proceed upwards to the next valve (No. 2), and perform the same operation there. Having arrived at A, it will float upon the surface three-fourths of its bulk out of water. Upon another ball in due course arriving under it, it will be lifted quite out of the water, and fall over the point D, pass into the right leg (containing air), and fall to valve No. 5, strike and open the small valve in its center, then open the large one, and pass through; this valve will then, by appropriate weights or springs, close; the ball will roll on through the bent tube (which is made in that form to gain time as well as to exhibit motion) to the next valve (No. 6), where it will perform the same operation, and then, falling upon the four balls at E, force the bottom one round the corner at C. This ball will proceed as did No. 8, and the rest in the same manner successively."

[58]

[59]

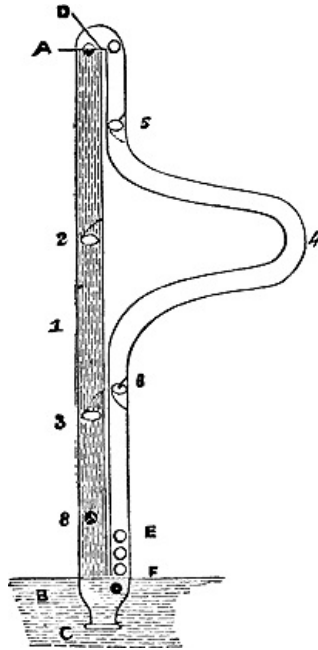

Fig. 13.

That an ordinary amateur mechanic should be misled by such arguments is perhaps not so surprising, when we remember that the famous John Bernoulli claimed to have invented a perpetual motion based on the difference between the specific gravities of two liquids. A translation of the original Latin may be found in the Encyclopædia Britannica, Vol. XVIII, page 555. Some of the premises on which he depends are, however, impossibilities, and Professor Chrystal concludes his notice of the invention thus: "One really is at a loss with Bernoulli's wonderful theory, whether to admire most the conscientious statement of the hypothesis, the prim logic of the demonstration—so carefully cut according to the pattern of the ancients—or the weighty superstructure built on so frail a foundation. Most of our perpetual motions were clearly the result of too little learning; surely this one was the product of too much."

A more simple device was suggested recently by a correspondent of "Power." He describes it thus:

The J-shaped tube A, Fig. 14, is open at both ends, but tapers at the lower end, as shown. A well-greased cotton rope C passes over the wheel B and through the small opening of the tube with practically little or no friction, and also without leakage. The tube is then filled with water. The rope above the line WX balances over the pulley, and so does that below the line YZ. The rope in the tube between these lines is lifted by the water, while the rope on the other side of the pulley between these lines is pulled downward by gravity.

[60]

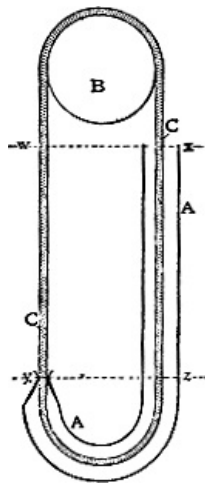

Fig. 14.

The inventor offers the above suggestion rather as a kind of puzzle than as a sober attempt to solve the famous problem, and he concludes by asking why it will not work?

In addition to the usual resistance or friction offered by the air to all motion, there are four drawbacks:

1. The friction in its bearings of the axle of the wheel B.
2. The power required to bend and unbend the rope.
3. The friction of the rope in passing through the water from z to x and its tendency to raise a portion of the water above the level of the water at x.
4. The friction at the point y, this last being the most serious of all. An "opening of the tube with practically little or no friction, and also without leakage" is a mechanical impossibility. In order to have the joint water-tight, the tube must hug the rope very tightly and this would make friction enough to prevent any motion. And the longer the column of water xz, the greater will be the tendency to leak, and consequently the tighter must be the joint and the greater the friction thereby created.

[61]

A favorite idea with perpetual-motion seekers is the utilization of the force of magnetism. Some time prior to the year 1579, Joannes Taisnierus wrote a book which is now in the British Museum and in which considerable space is devoted to "Continual Motions" and to the solving of this problem by magnetism. Bishop Wilkins in his "Mathematical Magick" describes one of the many devices which have been invented with this end in view. He says: "But amongst all these kinds of invention, that is most likely, wherein a loadstone is so disposed that it shall draw unto it on a reclined plane a bullet of steel, which steel as it ascends near to the loadstone, may be contrived to fall down through some hole in the plane, and so to return unto the place from whence at first it began to move; and, being there, the loadstone will again attract it upwards till coming to this hole, it will fall down again; and so the motion shall be perpetual, as may be more easily conceivable by this figure (Fig. 15):

"Suppose the loadstone to be represented at AB, which, though it have not strength enough to attract the bullet C directly from the ground, yet may do it by the help of the plane EF. Now, when the bullet is come to the top of this plane, its own gravity (which is supposed to exceed the strength of the loadstone) will make it fall into that hole at E; and the force it receives in this fall will carry it with such a violence unto the other end of this arch, that it will open the passage which is there made for it, and by its return will again shut it: so that the bullet (as at the first) is in the same place whence it was attracted, and, consequently must move perpetually."

[62]

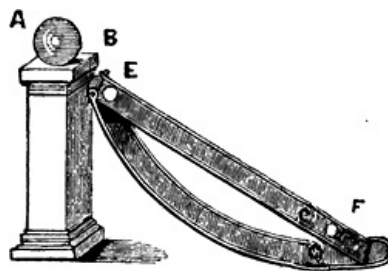

Fig. 15.

Notwithstanding the positiveness of the "must" at the close of his description, it is very obvious to any practical mechanic that the machine will not move at all, far less move perpetually, and the bishop himself, after carefully and conscientiously discussing the objections, comes to the same conclusion. He ends by saying: "So that none of all these magnetical experiments, which have been as yet discovered, are sufficient for the effecting of a perpetual motion, though these kind of qualities seem most conducive unto it, and perhaps hereafter it may be contrived from them."

It has occurred to several would-be inventors of perpetual motion that if some substance could be found which would prevent the passage of the magnetic force, then by interposing a plate of this material at the proper moment, between the magnet and the piece of iron to be attracted, a perpetual motion might be obtained. Several inventors have claimed that they had discovered such a non-conducting substance, but it is needless to say that their claims had no foundation in fact, and if they had discovered anything of the kind, it would have required just as much force to interpose it as would have been gained by the interposition. It has been fully proved that in every case where a machine was made to work apparently by the interposition of such a material, a fraud was perpetrated and the machine was really made to move by means of some concealed springs or weights.

[63]

A correspondent of the "Mechanic's Magazine" (Vol. xii, London, 1829), gives the following curious design for a "Self-moving Railway Carriage." He describes it as a machine which, were it possible to make its parts hold together unimpaired by rotation or the ravages of time, and to give it a path encircling the earth, would assuredly continue to roll along in one undeviating course until time shall be no more.

A series of inclined planes are to be erected in such a manner that a cone will ascend one (its sides forming an acute angle), and being raised to the summit, descend on the next (having parallel sides), at the foot of which it must rise on a third and fall on a fourth, and so continue to do alternately throughout.

The diagram, Fig. 16, is the section of a carriage A, with broad conical wheels *a, a*, resting on the inclined plane *b*. The entrance to the carriage is from above, and there are ample accommodations for goods and passengers. "The most singular property of this contrivance is, that its speed increases the more it is laden; and when checked on any part of the road, it will, when the cause of stoppage is removed, proceed on its journey by mere power of gravity. Its path may be a circular road formed of the inclined planes. But to avoid a circuitous route, a double road ought to be made. The carriage not having a retrograde motion on the inclined planes, a road to set out upon, and another to return by, are indispensable."

[64]

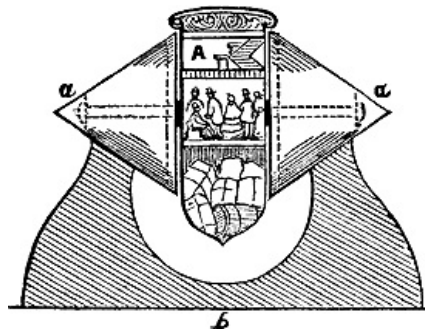

Fig. 16.

How any one could ever imagine that such a contrivance would ever continue in motion for even a short time, except, perhaps, on the famous *descensus averni*, must be a puzzle to every sane mechanic. I therefore give it as a climax to the absurdities which have been proposed in sober earnest. As a fitting close, however, to this chapter of human folly, I give the following joke from the "Penny Magazine," published by the Society for the Diffusion of Useful Knowledge.

"Father, I have invented a perpetual motion!" said a little fellow of eight years old. 'It is thus: I would make a great wheel, and fix it up like a water-wheel; at the top I would hang a great weight, and at the bottom I would hang a number of little weights; then the great weight would turn the wheel half round and sink to the bottom, because it is so heavy: and when the little weights reach the top they would sink down, because they are so many; and thus the wheel would turn round for ever.'"

[65]

The child's fallacy is a type of all the blunders which are made on this subject. Follow a projector in his description, and if it be not perfectly unintelligible, which it often is, it always proves that he expects to find certain of his movements alternately strong and weak—not according to the laws of nature—but according to the wants of his mechanism.

## 2. FALLACIES

Fallacies are distinguished from absurdities on the one hand and from frauds on the other, by the fact that without any intentionally fraudulent contrivances on the part of the inventor, they seem to produce results which have a tendency to afford to certain enthusiasts a basis of hope in the direction of perpetual motion, although usually not under that name, for that is always explicitly disclaimed by the promoters.

The most notable instance of this class in recent times was the application of liquid air as a source of power, the claim having been actually made by some of the advocates of this fallacy that a steamship starting from New York with 1000 gallons of liquid air, could not only cross the Atlantic at full speed but could reach the other side with more than 1000 gallons of liquid air on board—the power required to drive the vessel and to liquefy the surplus air being all obtained during the passage by utilizing the original quantity of liquid air that had been furnished in the



That this was equivalent to perpetual motion, pure and simple, was obvious even to those who were least familiar with such subjects, though the idea of calling it perpetual motion was sternly repudiated by all concerned—the term "perpetual motion" having become thoroughly offensive to the ears of common-sense people, and consequently tending to cast doubt over any enterprise to which it might be applied.

That liquid air is a real and wonderful discovery, and that for a certain small range of purposes it will prove highly useful, cannot be doubted by those who have seen and handled it and are familiar with its properties, but that it will ever be successfully used as an economical source of mechanical power is, to say the least, very improbable. That a small quantity of the liquid is capable of doing an enormous amount of work, and that under some conditions there is *apparently* more power developed than was originally required to liquefy the air, is undoubtedly true, but when a careful quantitative examination is made of the outgo and the income of energy, it will be found in this, as in every similar case, that instead of a gain there is a very decided and serious loss. The correct explanation of the fallacy was published in the "Scientific American," by the late Dr. Henry Morton, president of the Stevens Institute, and the same explanation and exposure were made by the writer, nearly fifty years ago, in the case of a very similar enterprise. The form of the fallacy in both cases is so similar and so interesting that I shall make no apology for giving the details.

About the year 1853 or 1854, two ingenious mechanics of Rochester, N. Y., conceived the idea that by using some liquid more volatile than water, a great saving might be effected in the cost of running an engine. At that time gasolene and benzine were unknown in commerce, and the same was true in regard to bisulphide of carbon, but as the process of manufacturing the latter was simple and the sources of supply were cheap and apparently unlimited, they adopted that liquid. The name of one of these inventors was Hughes and that of the other was Hill, and it would seem that each had made the invention independently of the other. They had a fierce conflict over the patent, but this does not concern us except to this extent, that the records of the case may therefore be found in the archives of the Patent Office at Washington, D.C. Hughes was backed by the wealth of a well-known lawyer of Rochester, whose son subsequently occupied a high office in the state of New York, and he constructed a beautiful little steam-engine and boiler, made of the very finest materials and with such skill and accuracy that it gave out a very considerable amount of power in proportion to its size. The source of heat was a series of lamps, fed, I think, with lard oil (this was before the days of kerosene), and the exhibition test consisted in first filling the boiler with water, and noting the time that it took to get up a certain steam pressure as shown by the gage. After this test, bisulphide of carbon was added to the water, and the time and pressure were noted. The difference was of course remarkable, and altogether in favor of the new liquid. The exhaust was carried into a vessel of cold water and as bisulphide of carbon is very easily condensed and very heavy, almost the entire quantity used was recovered and used over and over again.

[67]

But to the uninstructed onlooker, the most remarkable part of the exhibition was when the steam pressure was so far lowered that the engine revolved very slowly, and then, on a little bisulphide being injected into the boiler, the pressure would at once rise, and the engine would work with great rapidity. This seemed almost like magic.

[68]

The same experiment was tried on an engine of twelve horse-power, and with a like result. When the steam pressure had fallen so far that the engine began to move quite slowly, a quantity of the bisulphide would be injected into the boiler and the pressure would at once rise, the engine would move with renewed vigor, and the fly-wheel would revolve with startling velocity. All this was seen over and over again by myself and others. At that time the writer, then quite a young man, had just recovered from a very severe illness and was making a living by teaching mechanical drawing and making drawings for inventors and others, and in the course of business he was brought into contact with some parties who thought of investing in the new and apparently wonderful invention. They employed him to examine it and give an opinion as to its value. After careful consideration and as thorough a calculation as the data then at command would allow, he showed his clients that the tests which had been exhibited to them proved nothing, and that if a clear proof of the value of the invention was to be given, it must be after a run of many hours and not of a few minutes, and against a properly adjusted load, the amount of which had been carefully ascertained. This test was never made, or if made the results were not communicated to the prospective purchasers; the negotiations fell through, and the invention which was to have revolutionized our mechanical industries fell into "innocuous desuetude."

That the inventors were honest I have no doubt. They were themselves deceived when they saw the engine start off with tremendous velocity as soon as a little bisulphide of carbon was injected into the boiler, and they failed to see that this spurt, if I may use the expression, was simply due to a draft upon capital previously stored up. The capacity of bisulphide of carbon for heat is quite low, when compared with that of water; its vaporizing point is also much lower and consequently, an ordinary boiler full of hot water contains enough heat to vaporize a considerable quantity of bisulphide of carbon at a pretty high pressure.

[69]

In even a still greater measure the same is true of liquid air, and this was the underlying fallacy in the case of the tests made with liquid-air motors.

### 3. FRAUDS

But while the inventors of these schemes may have been honest, there is another class who deliberately set out to perpetrate a fraud. Their machines work, and work well, but there is always some concealed source of power, which causes them to move. As a general rule, such inventors form a company or corporation of unlimited "lie-ability," as De Morgan phrases it, and then they proceed by means of flaring prospectuses and liberal advertising, to gather in the dupes who are attracted by their seductive promises of enormous returns for a very small outlay. Perhaps the most widely known of these fraudulent schemes of recent years was the notorious Keeley motor, the originator of which managed to hoodwink a respectable old lady, and to draw from her enormous supplies of cash. At his death, however, the absolutely fraudulent nature of his contrivances was fully disclosed, and nothing more has been heard of his alleged discovery. But, while he lived and was able to put forward claims based upon some apparent results, he found plenty of fools who accepted the idea that there is nothing impossible to science. [70]

It is true that the Keeley motor was examined by several committees and some very respectable gentlemen acted in such a way as to give a seeming endorsement of the scheme, but it must not be supposed for an instant that any well-educated engineers and scientific men were deceived by Mr. Keeley's nonsense. The very fact that he refused to allow a complete examination of his machine by intelligent practical men, ought to have been enough to condemn his scheme, for if he had really made the discovery which he claimed there would have been no difficulty in proving it practically and thoroughly, and then he might have formed company after company that would have rewarded him with "wealth beyond the dreams of avarice."

The Keeley motor was not put forward as a perpetual motion; in these days none of these schemes is admitted to be a perpetual motion, for that term has now become exceedingly offensive and would condemn any invention; but the result is the same in the end, and the whole history of perpetual motion is permeated with frauds of this kind, some of them having been so simple that they were obvious to even the most unskilled observer, while others were exceedingly complicated and most ingeniously concealed. Many years ago a number of these fraudulent perpetual-motion machines were manufactured in America and sent over to Great Britain for exhibition, and quite a lucrative business was done by showing them in various towns. But the fraud was soon detected and the British police then made it too warm for these swindlers. [71]

Mr. Dircks, in his "Perpetuum Mobile," has given accounts of quite a number of these impostures. The following are some of the most notable:

M. Poppe of Tübingen tells of a clock made by M. Geiser, which was an admirable piece of mechanism and seemed to have solved this great problem in an ingenious and simple manner, but it deceived only for a time. When thoroughly examined inwardly and outwardly, some time after his death, it was found that the center props supporting its cylinders contained cleverly constructed, hidden clock-work, wound up by inserting a key in a small hole under the second-hand.

Another case was that of a man named Adams who exhibited, for eight or nine days, his pretended perpetual motion in a town in England and took in the natives for fifty or sixty pounds. Accident, however, led to a discovery of the imposture. A gentleman, viewing the machine took hold of the wheel or trundle and lifted it up a little, which probably disengaged the wheels that connected the hidden machinery in the plinth, and immediately he heard a sound similar to that of a watch when the spring is running down. The owner was in great anger and directly put the wheel into its proper position, and the machine again went around as before. The circumstance was mentioned to an intelligent person who determined to find out and expose the imposture. He took with him a friend to view the machine and they seated themselves one on each side of the table upon which the machine was placed. They then took hold of the wheel and trundle and lifted them up, there being some play in the pivots. Immediately the hidden spring began to run down and they continued to hold the machine in spite of the endeavors of the owner to prevent them. When the spring had run down, they placed the machine again on the table and offered the owner fifty pounds if it could then set itself going, but notwithstanding his fingering and pushing, it remained motionless. A constable was sent for, the impostor went before a magistrate and there signed a paper confessing his perpetual motion to be a cheat. [72]

In the "Mechanic's Magazine," Vol. 46, is an account of a perpetual motion, constructed by one Redhoeffler of Pennsylvania, which obtained sufficient notoriety to induce the Legislature to appoint a committee to enquire into its merits. The attention of Mr. Lukens was turned to the subject, and although the actual moving cause was not discovered, yet the deception was so ingeniously imitated in a machine of similar appearance made by him and moved by a spring so well concealed, that the deceiver himself was deceived and Redhoeffler was induced to believe that Mr. Lukens had been successful in obtaining a moving power in some way in which he himself had failed, when he had produced a machine so plausible in appearance as to deceive the public.

Instances of a similar kind might be multiplied indefinitely.

The experienced mechanic who reads the descriptions here given of the various devices which have been proposed for the construction of a perpetual-motion machine must be struck with the childish simplicity of the plans which have been offered; and those who will search the pages of the mechanical journals of the last century or who will examine the two closely printed volumes

in which Mr. Dircks has collected almost everything of the kind, will be astonished at the sameness which prevails amongst the offerings of these would-be inventors. Amongst the hundreds, or, perhaps, thousands, of contrivances which have been described, there is probably not more than a dozen kinds which differ radically from each other; the same arrangement having been invented and re-invented over and over again. And one of the strange features of the case is that successive inventors seem to take no note of the failure of those predecessors who have brought forward precisely the same combination of parts under a very slightly different form.

[73]

It is true that we occasionally find a very elaborate and apparently complicated machine, but in such cases it will be found, on close examination, to owe its apparent complexity to a mere multiplication of parts; no real inventive ingenuity is exhibited in any case.

Another singular characteristic of almost all those who have devoted themselves to the search for a perpetual motion is their absolute confidence in the success of the plans which they have brought forth. So confident are they in the soundness of their views and so sure of the success of their schemes that they do not even take the trouble to test their plans but announce them as accomplished facts, and publish their sketches and descriptions as if the machine was already working without a hitch. Indeed, so far was one inventor carried away with this feeling of confidence in the success of his machine that he no longer allowed himself to be troubled with any doubts as to the machine's *going* but was greatly puzzled as to what means he should take to *stop* it after it had been set in motion!

These facts, which are well known to all who have been brought into contact with this class of minds, explain many otherwise puzzling circumstances and enable us to place a proper value on assertions which, if not made so positively and by such apparently good authority, would be at once condemned as deliberate falsehoods. That falsehood, pure and simple, has formed the basis of a good many claims of this kind, there can be no doubt, but at the same time, it is probable that some of the claimants really deceived themselves and attributed to causes other than radical errors of theory, the fact that their machines would not continue to move.

[74]

While many have claimed the actual invention of a perpetual motion it is very certain that not one has ever succeeded. How, then, are we to explain the statements which have been made in regard to Orffyreus and the claims of the Marquis of Worcester? For both of these men it is claimed that they constructed wheels which were capable of moving perpetually and apparently strong testimony is offered in support of these assertions.

In the famous "Century of Inventions," published by the Marquis in 1663, four years before his death, the celebrated 56th article reads as follows (*verbatim et literatim*):

"To provide and make that all the Weights of the descending side of a Wheel shall be perpetually further from the Centre, then those of the mounting side, and yet equal in number and heft to the one side as the other. A most incredible thing, if not seen, but tried before the late king (of blessed memory) in the *Tower*, by my directions, two Extraordinary Embassadors accompanying His Majesty, and the Duke of *Richmond* and Duke *Hamilton*, with most of the Court, attending Him. The Wheel was 14. Foot over, and 40. Weights of 50. pounds apiece. Sir *William Balfore*, then Lieutenant of the *Tower*, can justifie it, with several others. They all saw, that no sooner these great Weights passed the Diameter-line of the lower side, but they hung a foot further from the Centre, nor no sooner passed the Diameter-line of the upper side, but they hung a foot nearer. Be pleased to judge the consequence."

Such is the account given by the Marquis himself, and that he exhibited such a wheel at the time and place which he names, I have not the least doubt. And that some of the weights on one side hung a foot further from the center than did weights on the other side is also no doubt true, but, as the judging of the "consequence" is left to ourselves we know that after the first impulse given to it had been expended, the wheel would simply stand still unless kept in motion by some external force.

[75]

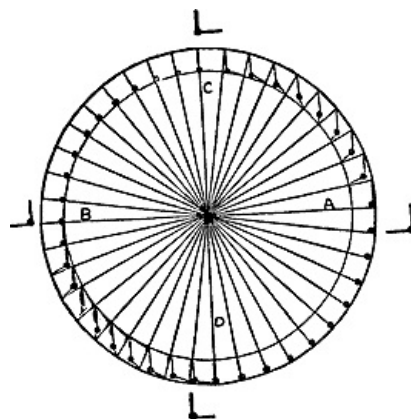

Fig. 17.

Mr. Dircks in his "Life, Times and Scientific Labours of the Second Marquis of Worcester," gives an engraving of a wheel which complies with all the conditions laid down by the Marquis and which is thus described:

"Let the annexed diagram, Fig. 17, represent a wheel of 14 feet in diameter, having 40 spokes, seven feet each, and with an inner rim coinciding with the periphery, at one foot distance all round. Next provide 40 balls or weights, hanging in the center of cords or chains two feet long. Now, fasten one end of this cord at the top of the center spoke C, and the other end of the cord to the next right-hand spoke one foot below the upper end, or on the inner ring; proceed in like manner with every other spoke in succession; and it will be found that, at A, the cord will have the position shown outside the wheel; while at B, C, and D, it will also take the respective positions, as shown on the outside. The result in this case will be, that all the weights on the side A, C, D, hang to the great or outer circle, while on the side B, C, D, all the weights are suspended from the lesser or inner circle. And if we reverse the motion of the wheel, turning it from the right to the left hand, we shall reverse these positions also (the lower end of the cord sliding in a groove towards a left-hand spoke), but without the wheel having any tendency to move of itself."

[76]

But it is quite as likely that the wheel constructed by the Marquis was like one of the "overbalancing" wheels described at the beginning of this article.

It is upon this "scantling" that has been based the claim that the Marquis really invented a perpetual motion, but to those who have seen much of inventors of this kind, the discrepancy between the suggested claim made by the Marquis and what we know must have been the actual results, is easily explained. The Marquis felt sure that the thing *ought to work*, and the excuse for its not doing so was probably the imperfect manner in which the wheel was made. Only put a little better work on it, says the inventor, and it will go.

Caspar Kaltoff, mechanician to the Marquis, probably got the wheel up in a hurry so as to exhibit it on the occasion of the king's visit to the tower. If he only had had a little more time he would have made a machine that would have worked. (?) I have heard the same excuse under almost the same circumstances, scores of times.

The case of Orffyreus was very different. The real name of this inventor was Jean Ernest Elie-Bessler, and he is said to have manufactured the name Orffyreus by placing his own name between two lines of letters, and picking out alternate letters above and below. He was educated for the church, but turned his attention to mechanics and became an expert clock maker. His character, as given by his contemporaries was fickle, tricky, and irascible. Having devised a scheme for perpetual motion he constructed several wheels which he claimed to be self-moving. The last one which he made was 12 feet in diameter and 14 inches deep, the material being light pine boards, covered with waxed cloth to conceal the mechanism. The axle was 8 inches thick, thus affording abundant space for concealed machinery.

[77]

This wheel was submitted to the Landgrave of Hesse who had it placed in a room which was then locked, and the lock secured with the Landgrave's own seal. At the end of forty days it was found to be still running.

Professor Gravesande having been employed by the Landgrave to make an examination and pronounce upon its merits, he endeavored to perform his work thoroughly; this so irritated Orffyreus that the latter broke the machine in pieces, and left on the wall a writing stating that he had been driven to do this by the impertinent curiosity of the Professor!

I have no doubt that this was a clear case of fraud, and that the wheel was driven by some mechanism concealed in the huge axle. As already stated, Orffyreus was at one time a clock maker; now clocks have been made to go for a whole year without having to be rewound, so that forty days was not a very long time for the apparatus to keep in motion.

[78]

Professor Gravesande seems to have had some faith in the invention, but then we must remember that it would not have been very difficult to deceive an honest old professor whose confidence in humanity was probably unbounded. The crowning argument against the genuineness of the motion was the fact that the inventor refused to allow a thorough examination, although a wealthy patron stood ready with a large reward if the machine could be proved to be what was claimed.

And now comes up the question which has arisen in regard to other problems, and will recur again and again to the end of the chapter: Is a perpetual motion machine one of the scientific impossibilities?

The answer to this question lies in the fact that there is no principle more thoroughly established than that no combination of machinery can create energy. So far as our present knowledge of nature goes we might as well try to create matter as to create energy, and the creation of energy is essential to the successful working of a perpetual-motion machine because some power must always be lost through friction and other resistances and must be supplied from some source if the machine is to keep on moving. And since the law of the conservation of energy makes it positive that no more power can be given out by a machine than was originally supplied to it, it seems as certain as anything can be that the construction of a perpetual-motion machine is one of the impossibilities.

## TRANSMUTATION OF THE METALS



HE "accursed thirst for gold" has existed from the earliest ages and, as the apostle says, "is the root of all evil." Those who have a greed for power, a craving for luxury, or a fever for lust, all think that their wildest dreams might be realized if they could only command sufficient gold. Never was there a more lurid picture of a mind inflamed with all these evil passions than that set forth by Ben Jonson in the Second Act of "The Alchemist," and who can doubt but that such desires and dreams spurred on many, either to engage in an actual search for the philosopher's stone, or to become the dupes of what Van Helmont calls "a diabolical crew of gold and silver sucking flies and leeches."

As we might naturally expect, the early history of alchemy is shrouded in myths and fables. Zosimos the Panopolite tells us that the art of Alchemy was first taught to mankind by demons, who fell in love with the daughters of men, and, as a reward for their favors, taught them all the works and mysteries of nature. On this Boerhaave remarks:

"This ancient fiction took its rise from a mistaken interpretation of the words of Moses, 'That the sons of God saw the daughters of men that they were fair, and they took them wives of all which they chose.'<sup>[2]</sup> From whence it was inferred that the sons of God were dæmons, consisting of a soul, and a visible but impalpable body, like the image in a looking-glass (to which notion we find several allusions in the evangelists); that they know all things, appeared to men and conversed with them, fell in love with women, had intrigues with them and revealed secrets. From the same fable probably arose that of the Sibyl, who is said to have obtained of Apollo the gift of prophecy, and revealing the will of heaven in return for a like favor. So prone is the roving mind of man to figments, which it can at first idly amuse itself with, and at length fall down and worship."

[80]

This idea of the supernatural origin of the arts permeates the ancient mythology which everywhere teaches that men were taught the sacred arts of medicine and chemistry by gods and demigods.

Modern science discards all these mythological accounts. Whatever knowledge the ancients acquired of medicine and chemistry was, no doubt, reached along two lines—pharmacy and metallurgy. That the pharmacist or apothecary exercised his calling at a very early period we have positive knowledge; thus in the Book of Ecclesiastes we are told that "dead flies cause the ointment of the apothecary to send forth a stinking savor," and that men at a very early day found out the means of working iron, copper, gold, silver, etc., is evident from the accounts given of Vulcan and Tubalcain, as well as from the remains of old tools and weapons. And that Alchemy, as it is generally understood, is a comparatively modern outgrowth of these two arts, is pretty certain. No mention of the art of converting the baser metals into gold, and no account of a universal medicine or elixir of life is to be found in any of the authentic writings of the ancients. Homer, Aristotle, and even Pliny are all silent on the subject, and those writings which treat of the art, and which claim an ancient origin, such as the books of Hermes Trismegistus, are now regarded by the best authorities as spurious—the evidence that they were the work of a far later age being irrefragable.

[81]

Several writers have taken the ground that the alchemical treatises which have come down to us from the early writers on the subject, are purely allegorical and do not relate to material things, but to the principles of a higher religion which, in those days, it was dangerous to expound in plain language. One or two elaborate works and several articles supporting this view have been published, but the common-sense reader who will glance through the immense collection of alchemical tracts gathered together by Mangetus in two folio volumes of a thousand pages each, will rise from such examination, very thoroughly convinced that it was the actual metal gold, and the fabled universal medicine that these writers had in view.

There can be little doubt that Geber, Roger Bacon, Albertus Magnus, Raymond Lully, Helvetius, Van Helmont, Basil Valentine, and others, describe very substantial things with a minuteness of detail which leaves no room for doubt as to their materiality though we cannot always be sure of their identity.

Some confusion of thought has been caused by the difference which has been made between the terms alchemy and chemistry and their applications. The word *alchemy* is simply the word chemistry with the Arabic word *al*, which signifies *the*, prefixed, and the history of alchemy is really the history of chemistry—wild and erratic in its beginnings, and giving rise to strange hopes and still stranger theories, but ever working along the line of discovery and progress. And, although many of the professional chemists or alchemists of the middle ages were undoubted charlatans and quacks, yet did we not have many of the same kind in the nineteenth century? We may use the word alchemist as a term of reproach, and apply it to these early workers because their theories appear to us to be absurd, but how do we know that the chemists of the twenty-second century will not regard us in a similar light, and set at naught the theories we so fondly cherish?

[82]

Only seven out of the large number of metals now catalogued by us were known to the ancients; these were gold, silver, mercury, copper, tin, lead, and iron. And as it happened that the list of so-called planets also numbered exactly seven, it was thought that there must be a

connection between the two, and, consequently, in the alchemical writings, each metal was called by the name of that one of the heavenly bodies which was supposed to be connected with it in influence and quality.

In the astronomy of the ancients, as is generally known, the earth occupied the center of the universe, and the list of planets included the sun and moon. After them came Mercury, Venus, Mars, Jupiter, and Saturn. To the metal gold was given the name of Sol, or the sun, on account of its brightness and its power of resisting corroding agents; hence the compounds of gold were known as solar compounds and solar medicines. As might have been expected, silver was assigned to Luna or the moon, and in the modern pharmacopœia such terms as lunar caustic and lunar salts still have a place. Mercury was, of course, appropriated to the planet of that name. Copper was named after Venus, and cupreous salts were known as venereal salts. Iron, probably from its being the metal chiefly used for making arms and armor, was dedicated to Mars, and we still speak of martial salts. Tin was named after Jupiter from his brilliancy, the compounds of tin being called jovial salts. The dull, leaden color of Saturn, with his apparently heavy and slow motion, seemed to fit him for association with lead, and we still have the saturnine ointment as a reminder of old alchemical times.

[83]

Of these metals gold was supposed to be the only one that was perfect, and the belief was general that if the others could be purified and perfected they would be changed to gold. Many of the old chemists worked faithfully and honestly to accomplish this, but the path to wealth seemed so direct and the means for deception were so ready and simple, that large numbers of quacks and charlatans entered the field and held out the most alluring inducements to dupes who furnished them liberally with money and other necessaries in the hope that when the discovery was made they would be put in possession of unbounded wealth. These dupes were easily deceived and led astray by simple frauds, which scarcely rose to the level of amateur legerdemain. In the "Memoirs of the Academy of Sciences" for 1772, M. Geoffroy gives an account of the various modes in which the frauds of these swindlers were carried on. The following are a few of their tricks: Instead of the mineral substances which they pretended to transmute they put a salt of gold or silver at the bottom of the crucible, the mixture being covered with some powdered crucible and gum water or wax so that it might look like the bottom of the crucible. Another method was to bore a hole in a piece of charcoal, fill the hole with fine filings of gold or silver, stopping it with powdered charcoal, mixed with some agglutinant so that the whole might look natural. Then when the charcoal burned away, the silver or gold was found in the bottom of the crucible. Or they soaked charcoal in a solution of these metals and threw the charcoal, when powdered, upon the material to be transmuted. Sometimes they whitened gold with mercury and made it pass for silver or tin, and the gold when melted was exhibited as the result of transmutation. A common exhibition was to dip nails in a liquid and to take them out apparently half converted into gold; these nails consisted of one-half iron neatly soldered to the other half, which was gold, and covered with something to conceal the color. The paint or covering was removed by the liquid. A very common trick was the use of a hollow, iron stirring rod; the hollow was filled with gold or silver filings, and neatly stopped with wax. When used to stir the contents of the crucible the wax melted and allowed the gold or silver to fall out.

[84]

These frauds were rendered all the more easy because of certain statements which were current in regard to successful attempts to convert lead and other metals into gold. These accounts were vouched for by well-known chemists and others of high standing. Perhaps the most famous of these is that given by Helvetius in his "Brief of the Golden Calf; Discovering the Rarest Miracle in Nature; how by the smallest portion of the Philosopher's Stone, a great piece of common lead was totally transmuted into the purest translucent gold, at the Hague in 1666." The following is Brande's abridgment of this singular account.

"The 27th day of December, 1666, in the afternoon, came a stranger to my house at the Hague, in a plebeick habit, of honest gravity and serious authority, of a mean stature and a little long face, black hair not at all curled, a beardless chin, and about forty-four years (as I guess) of age and born in North Holland. After salutation, he beseeched me with great reverence to pardon his rude accesses, for he was a lover of the Pyrotechnian art, and having read my treatise against the sympathetic powder of Sir Kenelm Digby, and observed my doubt about the philosophic mystery, induced him to ask me if I really was a disbeliever as to the existence of an universal medicine which would cure all diseases, unless the principal parts were perished, or the predestinated time of death come. I replied, I never met with an adept, or saw such a medicine, though I had fervently prayed for it. Then I said, 'Surely you are a learned physician.' 'No,' said he, 'I am a brass-founder, and a lover of chemistry.' He then took from his bosom-pouch a neat ivory box, and out of it three ponderous lumps of stone, each about the bigness of a walnut. I greedily saw and handled for a quarter of an hour this most noble substance, the value of which might be somewhere about twenty tons of gold; and having drawn from the owner many rare secrets of its admirable effects, I returned him this treasure of treasures with a most sorrowful mind, humbly beseeching him to bestow a fragment of it upon me in perpetual memory of him, though but the size of a coriander seed. 'No, no,' said he, 'that is not lawful, though thou wouldest give me as many golden ducats as would fill this room; for it would have particular consequences, and if fire could be burned of fire, I would at this instant rather cast it all into the fiercest flames.' He then asked if I had a private chamber whose prospect was from the public street; so I presently conducted him to my best furnished room backwards, which he entered, says Helvetius (in the true spirit of Dutch cleanliness), without wiping his shoes, which were full of snow and dirt. I now expected he would bestow some great secret upon me; but in vain. He asked for a piece of gold, and opening his doublet showed me five pieces of that precious metal which he wore upon a green riband, and which very much excelled mine in flexibility and

[85]

color, each being the size of a small trencher. I now earnestly again craved a crumb of the stone, and at last, out of his philosophical commiseration, he gave me a morsel as large as a rapeseed; but I said, 'This scanty portion will scarcely transmute four grains of lead.' 'Then,' said he, 'Deliver it me back:' which I did, in hopes of a greater parcel; but he, cutting off half with his nail, said: 'Even this is sufficient for thee.' 'Sir,' said I, with a dejected countenance, 'what means this?' And he said, 'Even that will transmute half an ounce of lead.' So I gave him great thanks, and said I would try it, and reveal it to no one. He then took his leave, and said he would call again next morning at nine. I then confessed, that while the mass of his medicine was in my hand the day before, I had secretly scraped off a bit with my nail, which I projected on lead, but it caused no transmutation, for the whole flew away in fumes. 'Friend,' said he, 'thou art more dexterous in committing theft than in applying medicine; hadst thou wrapt up thy stolen prey in yellow wax, it would have penetrated and transmuted the lead into gold.' I then asked if the philosophic work cost much or required long time, for philosophers say that nine or ten months are required for it. He answered, 'Their writings are only to be understood by the adepts, without whom no student can prepare this magistry. Fling not away, therefore, thy money and goods in hunting out this art, for thou shalt never find it.' To which I replied, 'As thy master showed it thee so mayest thou perchance discover something thereof to me who know the rudiments, and therefore, it may be easier to add to a foundation than begin anew.' 'In this art,' said he, 'it is quite otherwise, for unless thou knowest the thing from head to heel, thou canst not break open the glassy seal of Hermes. But enough; tomorrow at the ninth hour I will show thee the manner of projection.' But Elias never came again; so my wife, who was curious in the art whereof the worthy man had discoursed, teased me to make the experiment with the little spark of bounty the artist had left me; so I melted half an ounce of lead, upon which my wife put in the said medicine; it hissed and bubbled, and in a quarter of an hour the mass of lead was transmuted into fine gold, at which we were exceedingly amazed. I took it to the goldsmith, who judged it most excellent, and willingly offered fifty florins for each ounce."

[86]

Such is the celebrated history of Elias the artist and Dr. Helvetius.

Helvetius stood very high as a man and chemist, but in connection with this and some other narratives of the same kind, it may be well to remember that something over a hundred years before that time the celebrated Paracelsus had introduced laudanum.

[87]

The following is another history of transmutation, given by Mangetus, on the authority of M. Gros, a clergyman of Geneva, "of the most unexceptionable character, and at the same time a skilful physician and expert chemist."

"About the year 1650 an unknown Italian came to Geneva and took lodgings at the sign of the Green Cross. After remaining there a day or two, he requested De Luc, the landlord, to procure him a man acquainted with Italian, to accompany him through the town and point out those things which deserved to be examined. De Luc was acquainted with M. Gros, at that time about twenty years of age, and a student in Geneva, and knowing his proficiency in the Italian language, requested him to accompany the stranger. To this proposition he willingly acceded, and attended the Italian everywhere for the space of a fortnight. The stranger now began to complain of want of money, which alarmed M. Gros not a little, for at that time he was very poor, and he became apprehensive, from the tenor of the stranger's conversation, that he intended to ask the loan of money from him. But instead of this, the Italian asked him if he was acquainted with any goldsmith, whose bellows and other utensils they might be permitted to use, and who would not refuse to supply them with the different articles requisite for a particular process which he wanted to perform. M. Gros named a M. Bureau, to whom the Italian immediately repaired. He readily furnished crucibles, pure tin, quicksilver, and the other things required by the Italian. The goldsmith left his workshop, that the Italian might be under the less restraint, leaving M. Gros, with one of his own workmen as an attendant. The Italian put a quantity of tin into one crucible, and a quantity of quicksilver into another. The tin was melted in the fire and the mercury heated. It was then poured into the melted tin, and at the same time a red powder enclosed in wax was projected into the amalgam. An agitation took place and a great deal of smoke was exhaled from the crucible; but this speedily subsided, and the whole being poured out, formed six heavy ingots, having the color of gold. The goldsmith was called in by the Italian and requested to make a rigid examination of the smallest of these ingots. The goldsmith not content with the touch-stone and the application of aquafortis, exposed the metal on the cupel with lead and fused it with antimony, but it sustained no loss. He found it possessed of the ductility and specific gravity of gold; and full of admiration, he exclaimed that he had never worked before upon gold so perfectly pure. The Italian made him a present of the smallest ingot as a recompense and then, accompanied by M. Gros, he repaired to the mint, where he received from M. Bacuet, the mint-master, a quantity of Spanish gold coin, equal in weight to the ingots which he had brought. To M. Gros he made a present of twenty pieces on account of the attention that he had paid to him and after paying his bill at the inn, he added fifteen pieces more, to serve to entertain M. Gros and M. Bureau for some days, and in the meantime he ordered a supper, that he might, on his return, have the pleasure of supping with these two gentlemen. He went out, but never returned, leaving behind him the greatest regret and admiration. It is needless to add that M. Gros and M. Bureau continued to enjoy themselves at the inn till the fifteen pieces which the stranger had left, were exhausted."

[88]

Narratives such as these led even Bergman, a very able chemist of the period, to take the ground that "although most of these relations are deceptive and many uncertain, some bear such character and testimony that, unless we reject all historical evidence, we must allow them entitled to confidence."

A much more probable explanation is that the relators were either dreaming or deceived by clever legerdemain.

Of the possibility or impossibility of converting the more common metals into gold or silver, it would be rash to give a positive opinion. To say that gold, silver, lead, copper, etc., are elements and cannot be changed, is merely to say that we have not been able to decompose them. Water, potash, soda, and other substances, were at one time considered elements, and resisted all the efforts of the older chemists to resolve them into their components, but with the advent of more powerful means of analysis they were shown to be compounds, and it is not impossible that the so-called elements into which they were resolved may themselves be found to be compounds. This has happened in regard to some substances which were at one time announced as elements, and it is not impossible that it may happen in regard to others. The ablest chemists of the present day recognize this fully and are prepared for radical changes in our knowledge of the nature and constitution of matter. Amongst the new views is the hypothesis of Rutherford and Soddy, which, as given by Sir William Ramsay, in a recent article contributed by him to "Harper's Magazine," is that,

[89]

"atoms of elements of high atomic weight, such as radium, uranium, thorium, and the suspected elements polonium and actinium, are unstable; that they undergo spontaneous change into other forms of matter, themselves radioactive and themselves unstable; and that finally elements are produced, which, on account of their non-radioactivity, are as a rule, impossible to recognize, for their minute amount precludes the application of any ordinary test with success. The recognition of helium however, which is comparatively easy of detection, lends great support to this hypothesis."

At the same time we must not lose sight of the fact that the substances which we now recognize as elements have not only resisted the most powerful analytical agencies and dissociating forces, but have maintained their elemental character in spectrum analysis, and shown their presence as distinct elements in the sun and other heavenly bodies where they must have been subjected to the action of the most energetic decomposing forces. So that in the present state of our knowledge the near prospect of successful transmutation does not seem to be very bright, although we cannot regard it as impossible. In the article from which we have already quoted, Sir William Ramsay, after discussing the bearing of certain experiments in regard to the parting with and absorbing of energy by certain elements, says: "If these hypotheses are just, then the transmutation of the elements no longer appears an idle dream. The philosopher's stone will have been discovered, and it is not beyond the bounds of possibility that it may lead to that other goal of the philosophers of the dark ages—the *elixir vitæ*. For the action of living cells is also dependent on the nature and direction of the energy which they contain; and who can say that it will be impossible to control their action, when the means of imparting and controlling energy shall have been investigated!"

[90]

In the event of the discovery of a cheap method of producing gold, the change which would certainly occur in our financial or currency system would be important, if not revolutionary. It has become the fashion at present with certain writers to scout the so-called "quantitative theory" of money as if it were an exposed fallacy. Now the quantitative theory of money rests on one of the most well-grounded and firmly established principles in political economy: the trouble is that the writers in question do not understand it or even know what it is. At present, the production of gold barely keeps pace with the increasing demand for the metal as currency and in the arts, but if that production were increased ten-fold, the value of gold would decline and prices would go up astonishingly.

[91]

One of the objects which the better class of alchemists had in view was the making of gold to such an extent that it might become quite common and cease to be sought after by mankind. One alchemical writer says: "Would to God that all men might become adepts in our art, for then gold, the common idol of mankind, would lose its value and we should prize it only for its scientific teaching."

FOOTNOTES:

[2] Genesis vi, 2.

VI

[92]

THE FIXATION OF MERCURY

HIS is really one of the processes supposed to be involved in the transmutation of the metals and might, therefore, perhaps, with propriety, be included under that head. But as it has received special attention in the apocryphal works of Hermes Trismegistus, who is generally regarded as





the Father of Alchemy, it is frequently mentioned as one of the old scientific problems. Readers of Scott's novel, "Kenilworth," may remember that Wayland Smith, in his account of his former master, Demetrius Doboobius, describes him as a profound chemist who had "made several efforts to fix mercury, and judged himself to have made a fair hit at the philosopher's stone." Hermes, or, rather, those who wrote over his name, speaks in the jargon of the adepts, about "catching the flying bird," by which is meant mercury, and "drowning it so that it may fly no more." The usual means for effecting this was amalgamation with gold, or some other metal or solution in some acid.

To the ancient chemists mercury must have been one of the most interesting of objects. Its great heaviness, its metallic brilliancy, and its wonderful mobility, must all have combined to render it a subject for deep thought and an attractive object for experiment and investigation.

Living in a warm climate, as they did, there was no means at their command by which its fluidity could be impaired. This subtle substance seemed to defy the usual attempts to grasp it; it rolled about like a solid sphere, but offered no resistance to the touch, and when pressed it split up into innumerable smaller globules so that the problem of "fixing" it must have had a strange fascination for the thoughtful alchemist, especially when he found that, on subjection to a comparatively moderate degree of heat, this heavy metal disappeared in vapor and left not a trace behind.

[93]

I have often wondered what the old alchemists would have said if they had seen fluid mercury immersed in a clear liquid and brought out in the form of a lump of solid, bright metal. For, although this is not in any sense a solution of the problem, yet it is a most curious sight and one which was rarely seen before the discovery of the liquefaction of the gases. To Geber, Basil Valentine, Van Helmont, Helvetius, and men of their day, living in their climate, this startling phenomenon would have seemed nothing short of a miracle.

In modern times the solidification of mercury had been frequently witnessed by these who dwelt in northern climates and by the skilful use of certain freezing mixtures made up of ordinary salts, it is not difficult to exhibit this metal in the solid state at any time. But it was not until the discovery of the liquefaction of carbonic acid, nitrous oxide, and other gases by Faraday, about 1823, that the freezing of mercury became a common lecture-room experiment.

In the year 1862 the writer delivered a course of lectures on chemistry, in the city of Rochester, N. Y., and during the progress of these lectures he reduced carbonic acid first to the liquid, and then to the solid state, in the form of a white snow. The temperature of this snow was about  $-80^{\circ}$  Cent. ( $-176^{\circ}$  Fahr.) and when it was mixed with ether and laid on a quantity of mercury, the latter was quickly frozen. In this way it was easy to make a hammer-head of frozen mercury and drive a nail with it.

[94]

Another very interesting experiment was the freezing of a slender triangular bar of mercury which might be twisted, bent, and tied in a knot. This was done by folding a long strip of very stiff paper so as to make an angular trough into which the mercury was poured. This trough was then carefully leveled and a mixture of solid carbonic acid and ether was placed over the metal in the usual way. In a few seconds the mercury was frozen quite solid so that it could be lifted out by means of two pairs of wooden forceps and bent and knotted at will. But the most striking part of the experiment was the melting of this bar of mercury by means of a piece of ice. The moment the ice touched the mercury, the latter melted and fell down in drops in the same way that a bar of lead or solder melts when it is touched with a red-hot iron.

The melted mercury was allowed to fall into a tall ale-glass of water, the temperature of which had been reduced as nearly as possible to the freezing point. When the mercury came in contact with the cold water, the latter began to freeze and by careful manipulation it was possible to freeze a tube of ice through the center of the column of water. The effect of this under proper illumination was very striking.

Owing to the fact that the specific heat or thermal capacity of mercury is only about one-thirtieth of that of water, it requires a considerable amount of melted mercury to produce the desired result.

But these processes do not enable us to fix mercury in the alchemical sense; the accomplishment of that still remains an unsolved problem, and it is more than likely that it will remain so.

---

## VII

[95]

### THE UNIVERSAL MEDICINE AND THE ELIXIR OF LIFE

OVE of life is a characteristic of all animals, man included, and notwithstanding the fact that an occasional individual becomes so dissatisfied with his environment that he commits suicide, and also in the face of the poet's assertion that



most men and women are of the same way of thinking as Charmian, the attendant on Cleopatra, and "love long life better than figs." And the force of this general feeling is appealed to in the only one of the Mosaic commandments to which a promise is attached, the inducement for honoring father and mother being "that thy days may be long in the land that the Lord thy God giveth thee."

No wonder then that the old alchemists dreamed of a universal medicine that would not only prevent or cure sickness but that would renew the youth of the aged and the feeble, for in this, as in most other attempts at discovery, the wish was father to the thought. That the renewal of youth in the aged was supposed to be within the ability of the magicians and gods of old, we gather from the stories of Medea and Aeson and the ivory shoulder of Pelops, as referred to in Shakespeare, and explained in the "Shakespeare Cyclopeda."

Of the form of this supposed elixir we know very little for the language of the alchemists was so vague and mystical that it is often very difficult to ascertain their meaning with any approach to certainty. The following, which is a fair sample of their metaphorical modes of expressing themselves, is found in the works of Geber. In one of his writings, he exclaims: "Bring me the six lepers that I may cleanse them." Modern commentators explain this as being his mode of telling his readers that he would convert into gold the six inferior or, as they were called by the alchemists, the six imperfect metals. No wonder that Dr. Johnson adopted the idea that the word *gibberish* (anciently written *geberish*) owed its origin to an epithet applied to the language of Geber and his tribe.

[96]

Some have claimed that the elixir and the philosopher's stone were one and the same thing, and some of the writings of the old alchemists would seem to confirm this view. Thus, at the close of a formula for preparing the philosopher's stone, Carolus Musitanus gives the following admonition:

"Thus friend, you have a description of the universal medicine, not only for curing diseases and prolonging life, but also for transmuting all metals into gold. Give therefore thanks to Almighty God, who, taking pity on human calamities, has at last revealed this inestimable treasure, and made it known for the benefit of all."

And Brande tells us that "nearly all the alchemists attributed the power of prolonging life either to the philosopher's stone or to certain preparations of gold, imagining possibly that the permanence of that metal might be transferred to the human system. The celebrated Descartes is said to have supported such opinions; he told Sir Kenelm Digby that although he would not venture to promise immortality, he was certain that life might be lengthened to the period of that of the Patriarchs. His plan, however, seems to have been the very rational one of limiting all excess of diet and enjoining punctual and frugal meals."

[97]

It is an old saying that history repeats itself. About forty years ago certain medical practitioners strongly urged the use of salts of gold in the treatment of disease, and great hopes were entertained in regard to their efficacy. And the Keeley gold cure for drunkards is strongly in evidence, even at the present day.

On the other hand, some have held that the elixir was quite distinct from the stone by which metals might be transmuted into gold. In the second part of "King Henry IV," Falstaff (Act III, Scene 2, line 355), says of Shallow: "it shall go hard but I will make him a philosopher's two stones to me," and this saying of his has given considerable trouble to the commentators.

Warburton's explanation of this expression is, that "there was two stones, one of which was a universal medicine and the other a transmuter of base metals into gold." And in Churchyard's "Discourse and Commendation of those that can make Gold," we read of Remundus, who

Wrote sundry workes, as well doth yet  
    appeare  
Of stone for gold, and shewed plaine  
    and cleare  
A stone for health.

Johnson and some others have objected to this explanation, but it seems to be evident that Falstaff meant that he would get health and wealth from Shallow. He got the wealth to the extent of a thousand pounds.

The intense desire which exists in the human bosom for an elixir that will cure all diseases, and prolong life has made itself evident, even in recent times, and has called forth serious efforts on the part of men occupying prominent positions in the scientific world. Both in Europe and in this country suggestions have been made of fluids which, when injected into the veins of the old and the feeble, would renew youth and impart fresh strength. But alas! the results thus far attained have been anything but gratifying, and the probabilities against success in this direction are very strong.

[98]

The latest gleam of light comes from discoveries in connection with the radioactive elements, as the reader will find, on referring to Sir William Ramsay's utterance, which is given at the close of the article on the "Transmutation of the Metals," on a preceding page.

## ADDITIONAL "FOLLIES"

In addition to the seven "Follies," of which an account has been given in the preceding pages, there are a few which deserve to be classed with them, although they do not find a place in the usual lists. These are known as

PERPETUAL LAMPS.  
 THE ALKAHEST OR UNIVERSAL SOLVENT.  
 PALINGENESY.  
 THE POWDER OF SYMPATHY.

[100]

### PERPETUAL OR EVER-BURNING LAMPS

**P**ART of the sepulchral rites of the ancients consisted in placing lighted lamps in the tombs or vaults in which the dead were laid, and, in many cases, these lamps were carefully tended and kept continually burning. Some authors have claimed, however, that these men of old were able to construct lamps which burned perpetually and required no attention. In number 379 of the "Spectator" there is an anecdote of some one having opened the sepulcher of the famous Rosicrucius. There he discovered a lamp burning which a statue of clock-work struck into pieces. Hence, says the writer, the disciples of this visionary claimed that he had made use of this method to show that he had re-invented the ever-burning lamps of the ancients. And Fortunio Liceti wrote a book in which he collected a large number of stories about lamps, said to have been found burning in tombs or vaults. Ozanam fills eight closely printed pages with a discussion of the subject.

Attempts have been made to explain many of the facts upon which is based the claim that the ancients were able to construct perpetual lamps by the suggestion that the light sometimes seen on the opening of ancient tombs may have been due to the phosphorescence which is well known to arise during the decomposition of animal and vegetable matter. Decaying wood and dead fish are familiar objects which give out a light that is sufficient to render dimly visible the outlines of surrounding objects, and such a light, seen in the vicinity of an old lamp, might give rise to the impression that the lamp had been actually burning and that it had been blown out by sudden exposure to a draft of air.

[101]

Another supposition was that the flame, which was supposed to have been seen, may have been caused by the ignition of gases arising from the decomposition of dead bodies, and set on fire by the flambeaux or candles of the investigators, and it is quite possible that the occurrence of each of these phenomena may have given a certain degree of confirmation to preconceived ideas.

After the discovery of phosphorus in 1669, by Brandt and Kunckel, it was employed in the construction of luminous phials which could be carried in the pocket, and which gave out sufficient light to enable the user to see the hands of a watch on a dark night. Directions for making these luminous phials are very simple, and may be found in most of the books of experiments published prior to the introduction of the modern lucifer match. They were also used for obtaining a light by means of the old matches, which were tipped merely with a little sulphur, and which could not be ignited by friction. Such a match, after being dipped into one of these phosphorus bottles, would readily take fire by slight friction, and some persons preferred this contrivance to the old flint and steel, partly, no doubt, because it was a novelty. But these bottles were not in any sense perpetual, the light being due to the slow oxidation of the phosphorus so that, in a comparatively short time, the luminosity of the materials ceased. Nevertheless, it has been suggested that some form of these old luminous phials may have been the original perpetual lamp.

After the discovery of the phosphorescent qualities of barium sulphate or Bolognian phosphorus, as it was called, it was thought that this might be a re-discovery of the long-lost art of making perpetual lamps. But it is well known that this substance loses its phosphorescent power after being kept in the dark for some time, and that occasional exposure to bright sun-light is one of the conditions absolutely essential to its giving out any light at all. This condition does not exist in a dark tomb.

[102]

A few years ago phosphorescent salts of barium and calcium were employed in the manufacture of what was known as luminous paint. These materials shine in the dark with brilliancy sufficient to enable the observer to read words and numbers traced with them, but regular exposure to the rays of the sun or some other bright light is absolutely necessary to enable them to maintain their efficiency.

More recently it has been suggested that the ancients may have been acquainted with some

form of radioactive matter like radium, and that this was the secret of the lamps in question. It is far more likely, however, that the reports of their perpetual lamps were based upon mere errors of observation.

The perpetual lamp is, in chemistry, the counterpart of perpetual motion in mechanics—both violate the fundamental principle of the conservation of energy. And just as suggestions of impossible movements have been numerous in the case of perpetual motion, so impossible devices and constructions have been suggested in regard to perpetual lamps. Prior to the development, or even the suggestion of the law of the conservation of energy, it was believed that it might be possible to find a liquid which would burn without being consumed, and a wick which would feed the liquid to the flame without being itself destroyed. Dr. Plott suggested naphtha for the fluid and asbestos for the wick, but since kerosene oil, naphtha, gasolene, and other liquids of the kind have become common, every housewife knows that as her lamp burns, the oil, of whatever kind it may be, disappears.

[103]

Under present conditions the construction of a perpetual lamp is not a severely felt want; for constancy and brilliancy our present means of illumination are sufficient for almost all our requirements. Whether or not it would be possible to gather up those natural currents of electricity, which are suspected to flow through and over the earth, and utilize them for purposes of illumination, however feeble, it might be difficult to decide. But such means of perpetual electric lighting would be similar to a perpetual motion derived from a mountain stream. Such natural means of illumination already exist, and have existed for ages in the fire-giving wells of naphtha which are found on the shores of the Caspian sea, and in other parts of the east, and which have long been objects of adoration to the fire-worshippers.

As for the outcome of present researches into the properties of radium, polonium, and similar substances, and their possible applications, it is too early to form even a surmise.

---

## THE ALKAHEST OR UNIVERSAL SOLVENT

[104]



THE production of a universal solvent or alkahest was one of the special problems of the alchemists in their general search for the philosopher's stone and the means of transmuting the so-called inferior metals into gold and silver. Their idea of the way in which it would aid them to attain these ends does not seem to be very clearly stated in any work that I have consulted; probably they thought that a universal solvent would wash away all impurities from common materials and leave in absolute purity the higher substance, which constituted the gold of the adepts. But whatever their particular object may have been, it is well known that much time and labor were expended in the fruitless search.

The futility of such attempts was very well exposed by the cynical sceptic, who asked them what kind of vessel could they provide for holding such a liquid? If its solvent powers are such that it dissolves everything, it is very evident that it would dissolve the very material of the vessel in which it must be placed.

When hydrofluoric acid became a subject of investigation it was thought that its characteristics approached, more nearly than those of any other substance known, to those of the universal solvent, and the very difficulty above suggested, presented itself strongly to the chemists who experimented with it. Not only common metals but glass and porcelain were acted upon by this wonderfully energetic liquid and when attempts were made to isolate the fluorine, even the platinum electrodes were corroded and destroyed. Vessels of pure silver and of lead served tolerably well, but Davy suggested that the most scientific method of constructing a containing vessel would be to use a compound in which fluorine was already present to the point of saturation. As there is a limit to the amount of fluorine with which any base can combine, such a vessel would be proof against its solvent action. I am not aware, however, that the suggestion was ever carried into actual practice with success.

[105]

---

## PALINGENESY

[106]



HIS singular delusion may have been partly due to errors of observation, the instruments and methods of former times having been notably crude and unreliable. This fact, taken in connection with the wild theories upon which the natural sciences of the middle ages were based, is a sufficient explanation of some of the extraordinary statements made by Kircher, Schott, Digby, and others.

By palingenesy these writers meant a certain chemical process by means of which a plant or an animal might be revived from its ashes. In other words a sort of material resurrection. Most of

the accounts given by the old authors go no further than to assert that by proper methods the ashes of plants, when treated with water, produce small forests of ferns and pines. Thus, an English chemist, named Coxe, asserts that having extracted and dissolved the essential salts of fern, and then filtered the liquor, he observed, after leaving it at rest for five or six weeks, a vegetation of small ferns adhering to the bottom of the vessel. The same chemist, having mixed northern potash with an equal quantity of sal ammoniac, saw, some time after, a small forest of pines and other trees, with which he was not acquainted, rising from the bottom of the vessel.

And Kircher tells us in his "Ars Magnetica" that he had a long-necked phial, hermetically sealed, containing the ashes of a plant which he could revive at pleasure by means of heat; and that he showed this wonderful phenomenon to Christina, Queen of Sweden, who was highly delighted with it. Unfortunately he left this valuable curiosity one cold day in his window and it was entirely destroyed by the frost. Father Schott also asserts that he saw this chemical wonder which, according to his account, was a rose revived from its ashes. And he adds that a certain prince having requested Kircher to make him one of the same kind, he chose rather to give up his own than to repeat the operation.

[107]

Even the celebrated Boyle, though not very favorable to palingenesis, relates that having dissolved in water some verdigris, which, as is well known, is produced by combining copper with the acid of vinegar, and having caused this water to congeal, by means of artificial cold, he observed, at the surface of the ice, small figures which had an exact resemblance to vines.

In this connection it is well to bear in mind that in Boyle's time almost all vinegar was really what its name implies—*sour wine* (*vin aigre*)—and verdigris or copper acetate was generally prepared by exposing copper plates to the action of refuse grapes which had been allowed to ferment and become sour. Therefore to him it might not have seemed so very improbable that the green crystals which appeared on the surface of the ice were, in reality, minute resuscitated grape-vines.

The explanation of these facts given by Father Kircher is worthy of the science of the times. He tells us that the seminal virtue of each mixture is contained in its salts and these salts, unalterable by their nature, when put in motion by heat, rise in the vessel through the liquor in which they are diffused. Being then at liberty to arrange themselves at pleasure, they place themselves in that order in which they would be placed by the effect of vegetation, or the same as they occupied before the body to which they belonged had been decomposed by the fire; in short, they form a plant, or the phantom of a plant, which has a perfect resemblance to the one destroyed.

[108]

That the operators have here mistaken for true vegetable growth the fern-like crystals of the salts which exist in the ashes of all plants is very obvious. Their knowledge of plant structure was exceedingly limited and their microscopes were so imperfect that imagination had free scope. As seen under our modern microscopes, there are few prettier sights than the crystallization of such salts as sal ammoniac, potassic nitrate, barium chloride, etc. The crystals are actually seen to grow and it would not require a very great stretch of the imagination to convince one that the growth is due to a living organism. Indeed, this view has actually been taken in an article which recently appeared in a prominent magazine. The writer of that article sees no difference between the mere aggregation of inorganic particles brought together by voltaic action and the building up of vital structures under the influence of organic forces. This is simply materialism run mad.

Perhaps the finest illustration of such crystallization is to be found in the deposition of silver from a solution of the nitrate as seen under the microscope. A drop of the solution is placed on a glass slide and while the observer watches it through a low power, a piece of copper wire or, preferably, a minute quantity of the amalgam of tin and mercury, such as is used for "silvering" cheap looking glasses, is brought into contact with it. Chemical decomposition at once sets in and then the silver thus deposited forms one element of a very minute voltaic couple and fresh crystals of silver are deposited upon the silver already thrown down. When the illumination of this object under the microscope is properly managed, the appearance, which resembles that shown in Fig. 18, is exceedingly brilliant, and beautiful beyond description.

[109]



Fig. 18.

That imagination played strange pranks in the observations of the older microscopists is shown by some of the engravings found in their books. I have now before me a thick, dumpy quarto in which the so-called seminal animalcules are depicted as little men and women, and I have no

doubt that, to the eye of this early observer, they had that appearance. But the microscopists of to-day know better.

Sir Kenelm Digby, whose name is associated with the Sympathetic Powder, tells us that he took the ashes of burnt crabs, dissolved them in water and, after subjecting the whole to a tedious process, small crabs were produced in the liquor. These were nourished with blood from the ox, and, after a time, left to themselves in some stream where they thrived and grew large.

[110]

Now, although Evelyn, in his diary, declares that "Sir Kenelm was an errant mountebank," it is quite possible that he was honest in his account of his experiments and that he was merely led astray by the imperfection of his instruments of observation. It is more than likely that the creatures which Digby saw were entomostraca introduced in the form of ova which, unless a good microscope be used, are quite invisible. These would develop rapidly and might easily be mistaken for some species of crab, though, when examined with proper instruments, all resemblance vanishes. When let loose in a running stream it would evidently be impossible to trace their identity and follow their growth.

But while some of these stories may have originated in errors of observation this will hardly explain some of the statements made by those who have advocated this strange doctrine. Father Schott, in his "Physica Curiosa," gives an account of the resurrection of a sparrow and actually gives an engraving in which the bird is shown in a bottle revived!

Although the subject, of itself, is not worthy of a moment's consideration, it deserves attention as an illustration of the extraordinary vagaries into which the human mind is liable to fall.

---

## THE POWDER OF SYMPATHY

[111]



HIS curious occult method of curing wounds is indissolubly associated with the name of Sir Kenelm Digby (born 1603, died 1665), though it was undoubtedly in use long before his time. He himself tells us that he learned to make and apply the drug from a Carmelite, who had traveled in the east, and whom he met in Florence, in 1622. The descendants of Digby are still prominent in England, and O. W. Holmes, in his "One Hundred Days in Europe," tells us that he had met a Sir Kenelm Digby, a descendant of the famous Sir Kenelm of the seventeenth century, and that he could hardly refrain from asking him if he had any of his ancestor's famous powder in his pocket.

Digby was a student of chemistry, or at least of the chemistry of those days, and wrote books of Recipes and the making of "Methington [metheglin or mead?] Syder, etc." He was, as we have seen in the previous article, a believer in palingenesis and made experiments with a view to substantiate that strange doctrine. Evelyn calls him an "errant quack," and he may have been given to quackery, but then the loose scientific ideas of those days allowed a wide range in drawing conclusions which, though they seem absurd to us, may have appeared to be quite reasonable to the men of that time.

From his book on the subject,<sup>[3]</sup> we learn that the wound was never to be brought into contact with the powder. A bandage was to be taken from the wound, immersed in the powder, and kept there until the wound healed.

[112]

This beats the absent treatment of Christian Science!

The powder was simply pulverized vitriol, that is, ferric sulphate, or sulphate of iron.

There was another and probably an older method of using sympathetic powders and salves; this was to apply the supposed curative to the weapon which caused the wound, instead of the wound itself. In the "Lay of the Last Minstrel," Scott gives an account of the way in which the Lady of Buccleuch applied this occult surgery to the wound of William of Deloraine:

"She drew the splinter from the  
wound,  
And with a charm she stanch'd the  
blood.  
She bade the gash be cleansed and  
bound:  
No longer by his couch she stood;  
But she has ta'en the broken lance.  
And washed it from the clotted  
gore,  
And salv'd the splinter o'er and  
o'er.  
William of Deloraine, in trance,  
Whene'er she turned it round and  
round

Twisted as if she galled his wound.  
Then to her maidens she did say,  
That he should be whole man and  
sound,  
Within the course of a night and  
day.  
Full long she toiled, for she did rue  
Mishap to friend so stout and  
true."<sup>[4]</sup>

That no direct benefit could have been derived from such a mode of treatment must be obvious, but De Morgan very plausibly claims that in the then state of surgical and medical knowledge, it was really the very best that could have been adopted. His argument is as follows: "The sympathetic powder was that which cured by anointing the weapon with its salve instead of the wound. I have been long convinced that it was efficacious. The directions were to keep the wound clean and cool, and to take care of diet, rubbing the salve on the knife or sword. If we remember the dreadful notions upon drugs which prevailed, both as to quantity and quality, we shall readily see that any way of *not* dressing the wound, would have been useful. If the physicians had taken the hint, had been careful of diet, etc., and had poured the little barrels of medicine down the throat of a practicable doll, *they* would have had their magical cures as well as the surgeons. Matters are much improved now; the quantity of medicine given, even by orthodox physicians, would have been called infinitesimal by their professional ancestors. Accordingly, the College of Physicians has a right to abandon its motto, which is, *Ars longa, vita brevis*, meaning, *Practice is long, so life is short.*"

[113]

As set forth by Digby and others, the use of the Powder of Sympathy is free from all taint of witchcraft or magic, but, in another form, it was wholly dependent upon incantations and other magical performances. This idea of sympathetic action was even carried so far as to lead to attempts to destroy or injure those whom the operator disliked. In some cases this was done by moulding an image in wax which, when formed under proper occult influences, was supposed to have the power of transferring to the victim any injuries inflicted on the image. Into such images pins and knives were thrust in the hope that the living original would suffer the same pains and mutilations that would be inflicted if the knives or pins were thrust into him, and sometimes the waxen form was held before the fire and allowed to melt away slowly in the hope that the prototype would also waste away, and ultimately die. Shakespeare alludes to this in the play of King John. In Act v., Scene 4, line 24, Melun says:

[114]

"A quantity of life  
Which bleeds away, even as a form  
of wax,  
Resolveth from his figure 'gainst the  
fire?"

And Hollinshed tells us that "it was alleged against Dame Eleanor Cobham and her confederates that they had devised an image of wax, representing the king, which, by their sorcerie, by little and little consumed, intending thereby, in conclusion, to waste and destroy the king's person."

In these cases, however, the operator always depended upon certain occult or demoniacal influences, or, in other words, upon the art of magic, and therefore examples of this kind do not come within the scope of the present volume. In the case of the Powder of Sympathy the results were supposed to be due entirely to natural causes.

#### FOOTNOTES:

[3] Touching the Cure of Wounds by the Powder of Sympathy. With Instructions how to make the said Powder. Rendered faithfully out of French into English by R. White, Gent. London, 1658.

[4] Canto III. Stanza 23.

---

## A SMALL BUDGET OF PARADOXES, ILLUSIONS, AND MARVELS

---

[115]

[117]

# THE FOURTH DIMENSION AND THE POSSIBILITY OF A NEW SENSE AND NEW SENSE-ORGAN



HIS subject has now found its way not only into semi-scientific works but into our general literature and magazines. Even our novel-writers have used suggestions from this hypothesis as part of the machinery of their plots so that it properly finds a place amongst the subjects discussed in this volume.

Various attempts have been made to explain what is meant by "the fourth dimension," but it would seem that thus far the explanations which have been offered are, to most minds, vague and incomprehensible, this latter condition arising from the fact that the ordinary mind is utterly unable to conceive of any such thing as a dimension which cannot be defined in terms of the three with which we are already familiar. And I confess at the start that I labor under the superlative difficulty of not being able to form any conception of a fourth dimension, and for this incapacity my only consolation is, that in this respect I am not alone. I have conversed upon the subject with many able mathematicians and physicists, and in every case I found that they were in the same predicament as myself, and where I have met men who professed to think it easy to form a conception of a fourth dimension, I have found their ideas, not only in regard to the new hypothesis, but to its correlations with generally accepted physical facts, to be nebulous and inaccurate. [118]

It does not follow, however, that because myself and some others cannot form such a clear conception of a fourth dimension as we can of the third, that, therefore, the theory is erroneous and the alleged conditions non-existent. Some minds of great power and acuteness have been incapable of mastering certain branches of science. Thus Diderot, who was associated with d'Alembert, the famous mathematician, in the production of "L'Encyclopedie," and who was not only a man of acknowledged ability, but who, at one time, taught mathematics and wrote upon several mathematical subjects, seems to have been unable to master the elements of algebra. The following anecdote regarding his deficiency in this respect is given by Thiébault and indorsed by Professor De Morgan: At the invitation of the Empress, Catherine II, Diderot paid a visit to the Russian court. He was a brilliant conversationalist and being quite free with his opinions, he gave the younger members of the court circle a good deal of lively atheism. The Empress herself was very much amused, but some of her councillors suggested that it might be desirable to check these expositions of strange doctrines. As Catherine did not like to put a direct muzzle on her guest's tongue, the following plot was contrived. Diderot was informed that a learned mathematician was in possession of an algebraical demonstration of the existence of God and would give it to him before all the court if he desired to hear it. Diderot gladly consented, and although the name of the mathematician is not given, it is well known to have been Euler. He advanced toward Diderot, and said in French, gravely, and in a tone of perfect conviction: "*Monsieur, (a + bn) / n = x, therefore, God exists; reply!*" Diderot, to whom algebra was Hebrew, was embarrassed and disconcerted, while peals of laughter rose on all sides. He asked permission to return to France at once, which was granted. [119]

Even such a mind as that of Buckle, who was generally acknowledged to be a keen-sighted thinker, could not form any idea of a geometrical line—that is, of a line without breadth or thickness, a conception which has been grasped clearly and accurately by thousands of school-boys. He therefore asserts, positively, that there are no lines without breadth, and comes to the following extraordinary conclusions:

"Since, however, the breadth of the faintest line is so slight as to be incapable of measurement, except by an instrument under the microscope, it follows that the assumption that there can be lines without breadth is so nearly true that our senses, when unassisted by art, can not detect the error. Formerly, and until the invention of the micrometer, in the seventeenth century, it was impossible to detect it at all. Hence, the conclusions of the geometrician approximate so closely to truth that we are justified in accepting them as true. The flaw is too minute to be perceived. But that there is a flaw appears to me certain. It appears certain that, whenever something is kept back in the premises, something must be wanting in the conclusion. In all such cases, the field of inquiry has not been entirely covered; and part of the preliminary facts being suppressed, it must, I think, be admitted that complete truth be unattainable, and that no problem in geometry has been exhaustively solved."<sup>[5]</sup>

The fallacy which underlies Mr. Buckle's contention is thus clearly exposed by the author of "The Natural History of Hell." [120]

"If it be conceded that lines have breadth, then all we have to do is to assign some definite breadth to each line—say the one-thousandth of an inch—and allow for it. But the lines of the geometer have no breadth. All the micrometers of which Mr. Buckle speaks depend, either directly or indirectly, upon lines for their graduations, and the positions of these lines are indicated by rulings or scratches. Now, in even the finest of these rulings, as, for example, those of Nobert or Fasoldt, where the ruling or scratching, together with its accompanying space, amounts to no more than the one hundred and fifty thousandth part of an inch, the scratch has a perceptible breadth. But this broad scratch is not the line recognized by the microscopist, to say nothing of the geometer.



The true line is a line which lies in the very center of this scratch and it is certain that this central line has absolutely no breadth at all."<sup>[6]</sup>

It must be very evident that if Mr. Buckle's contention that geometrical lines have breadth were true, then some of the fundamental axioms of geometry must be false. It could no longer hold true that "the whole is equal to all its parts taken together," for if we divide a square or a circle into two parts by means of a line which has breadth, the two parts cannot be equal to the whole as it formerly was. As a matter of fact, Mr. Buckle's lines are saw-cuts, not geometrical lines. Geometrical points, lines, and surfaces, have no material existence and can have none. An ideal conception and a material existence are two very different things.

A very interesting book<sup>[7]</sup> has been written on the movements and feelings of the inhabitants of a world of two dimensions. Nevertheless, if we know anything at all, we know that such a world could not have any actual existence and when we attempt to form any mental conception of it and its inhabitants, we are compelled to adopt, to a certain extent, the idea of the third dimension. [121]

But at the same time we must remember that since the ordinary mechanic and the school-boy who has studied geometry, find no difficulty in conceiving of points without magnitude, lines without breadth, and surfaces without thickness—conceptions which seem to have been impossible to Buckle, a man of acknowledged ability—it may be possible that minds constituted slightly differently from that of myself and some others, might, perhaps, be able to form a conception of a fourth dimension.

Leaving out of consideration the speculations of those who have woven this idea into romances and day-dreams we find that the hypothesis of a fourth dimension has been presented by two very different classes of thinkers, and the discussion has been carried on from two very different standpoints.

The first suggestion of this hypothesis seems to have come from Kant and Gauss and to have had a purely metaphysical origin, for, although attempts have been made to trace the idea back to the famous phantoms of Plato, it is evident that the ideas then advanced had nothing in common with the modern theory of the existence of a fourth dimension. The first hint seems to have been a purely mathematical one and did not attract any very general attention. It was, however, seized upon by a certain branch of the transcendentalists, closely allied to the spiritualists, and was exploited by them as a possible explanation of some curious and mysterious phenomena and feats exhibited by certain Indian and European devotees. This may have been done merely for the purpose of mystifying and confounding their adversaries by bringing forward a striking illustration of Hamlet's famous dictum— [122]

"There are more things in heaven and  
earth, Horatio,  
Than are dreamt of in your philosophy."

A very fair statement of this view is thus given by Edward Carpenter:<sup>[8]</sup>

"There is another idea which modern science has been familiarizing us with, and which is bringing us towards the same conception—that, namely, of the fourth dimension. The supposition that the actual world has four space-dimensions instead of three makes many things conceivable which otherwise would be incredible. It makes it conceivable that apparently separate objects, e. g., distinct people, are really physically united; that things apparently sundered by enormous distances of space are really quite together; that a person or other object might pass in and out of a closed room without disturbance of walls, doors or windows, etc., and if this fourth dimension were to become a factor of our consciousness it is obvious that we should have means of knowledge which, to the ordinary sense, would appear simply miraculous. There is much, apparently, to suggest that the consciousness attained to by the Indian gñanis in their degree, and by hypnotic subjects in theirs, is of this fourth dimensional order.

"As a solid is related to its own surface, so, it would appear, is the cosmic consciousness related to the ordinary consciousness. The phases of the personal consciousness are but different facets of the other consciousness; and experiences which seem remote from each other in the individual are perhaps all equally near in the universal. Space itself, as we know it, may be practically annihilated in the consciousness of a larger space, of which it is but the superficies; and a person living in London may not unlikely find that he has a back door opening quite simply and unceremoniously out in Bombay."

On the other hand, the mathematicians, looking at it as a purely speculative idea, have endeavored to arrive at definite conclusions in regard to what would be the condition of things if the universe really exists in a fourth, or even in some higher dimension. Professor W. W. R. Ball tells us that [123]

"the conception of a world of more than three dimensions is facilitated by the fact that there is no difficulty in imagining a world confined to only two dimensions—which we may take for simplicity to be plane—though equally well it might be a spherical or other surface. We may picture the inhabitants of flatland as moving either on the surface of a plane or between two parallel and adjacent planes. They could move in any direction along the plane, but they could not move perpendicularly to it, and would have no consciousness that such a motion was possible. We may suppose them to have no thickness, in which case they would be mere geometrical abstractions; or we may think of them as having a small but uniform thickness, in which case they would be realities."

"If an inhabitant of flatland was able to move in three dimensions, he would be credited with supernatural powers by those who were unable so to move; for he could appear or disappear at will; could (so far as they could tell) create matter or destroy it, and would be free from so many constraints to which the other inhabitants were subject that his actions would be inexplicable to them."

"Our conscious life is in three dimensions, and naturally the idea occurs whether there may not be a fourth dimension. No inhabitant of flatland could realize what life in three dimensions would mean, though, if he evolved an analytical geometry applicable to the world in which he lived, he might be able to extend it so as to obtain results true of that world in three dimensions which would be to him unknown and inconceivable. Similarly we cannot realize what life in four dimensions is like, though we can use analytical geometry to obtain results true of that world, or even of worlds of higher dimensions. Moreover, the analogy of our position to the inhabitants of flatland enables us to form some idea of how inhabitants of space of four dimensions would regard us."

[124]

"If a finite solid was passed slowly through flatland, the inhabitants would be conscious only of that part of it which was in their plane. Thus they would see the shape of the object gradually change and ultimately vanish. In the same way, if a body of four dimensions was passed through our space, we should be conscious of it only as a solid body (namely, the section of the body by our space) whose form and appearance gradually changed and perhaps ultimately vanished. It has been suggested that the birth, growth, life, and death of animals, may be explained thus as the passage of finite four-dimensional bodies through our three-dimensional space."

Attempts have been made to construct drawings and models showing a four-dimensional body. The success of such attempts has not been very encouraging.

Investigators of this class look upon the actuality of a fourth dimension as an unsolved question, but they hold that, provided we could see our way clear to adopt it, it would open up wondrous possibilities in the way of explaining abstruse and hitherto inexplicable physical conditions and phenomena.

There is obviously no limit to such speculations, provided we assume the existence of such conditions as are needed for our purpose. Too often, however, those who indulge in such day-dreams begin by assuming the impossible, and end by imagining the absurd.

We have so little positive knowledge in regard to the ultimate constitution of matter and even in regard to the actual character of the objects around us, which are revealed to us through our senses, that the field in which our imagination may revel is boundless. Perhaps some day the humanity of the present will merge itself into a new race, endowed with new senses, whose revelations are to us, for the present, at least, utterly inconceivable.

[125]

The possibility of such a development may be rendered more clear if we imagine the existence of a race devoid of the sense of hearing, and without the organs necessary to that sense. They certainly could form no idea of sound, far less could they enjoy music or oratory, such as afford us so much delight. And, if one or more of our race should visit these people, how very strange to them would appear those curious appendages, called ears, which project from the sides of our heads, and how inexplicable to them would be the movements and expressions of intelligence which we show when we talk or sing? It is certain that no development of the physical or mathematical sciences could give them any idea whatever of the sensations which sound, in its various modifications, imparts to us, and neither can any progress in that direction enable us to acquire any idea of the revelations which a new sense might open up to us. Nevertheless, it seems to me that the development of new senses and new sense organs is not only more likely to be possible, but that it is actually more probable, than any revelation in regard to a fourth dimension.

#### FOOTNOTES:

- [5] "History of Civilization in England." American edition, Vol. II, page 342.
- [6] "The Natural History of Hell," by John Phillipson, page 37.
- [7] "Flatland," by E. A. Abbott. London, 1884.
- [8] "From Adam's Peak to Elephanta—" page 160.

## HOW A SPACE MAY BE APPARENTLY ENLARGED BY CHANGING ITS SHAPE

[126]



THE following is a curious illustration of the errors to which careless observers may be subject:

Draw a square, like Fig. 19, and divide the sides into 8 parts each. Join the points of division in opposite sides so as to divide the whole square into 64 small squares. Then draw the lines shown in black and cut up the drawing into four pieces. The lines indicating the cuts have been made quite heavy so as to show up clearly, but on the actual card they may be made quite light. Now, put the four pieces together, so as to form the rectangle shown in Fig. 20. Unless the scale, to which the drawing is made is quite large and the work very accurate, it will seem that the rectangle contains 5 squares one way and 13 the other which, when multiplied together, give 65 for the number of small squares, being an apparent gain of one square by the simple process of cutting.

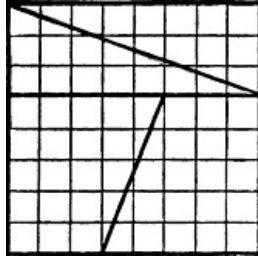

Fig. 19.

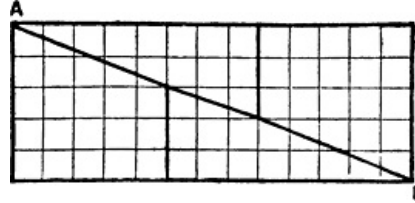

Fig. 20.

This paradox is very apt to puzzle those who are not familiar with accurate drawings. Of course, every person of common sense knows that the card or drawing is not made any larger by cutting it, but where does the 65th small square come from? [127]

On careful examination it will be seen that the line AB, Fig. 20, is not quite straight and the three parts into which it is divided are thus enabled to gain enough to make one of the small squares. On a small scale this deviation from the straight line is not very obvious, but make a larger drawing, and make it carefully, and it will readily be seen how the trick is done.

---

## CAN A MAN LIFT HIMSELF BY THE STRAPS OF HIS BOOTS? [128]



THINK it was the elder Stephenson, the famous engineer, who told a man who claimed the honor of having invented a perpetual motion, that when he could lift himself over a fence by taking hold of his waist-band, he might hope to accomplish his object. And the query which serves as a title for this article has long been propounded as one of the physical impossibilities. And yet, perhaps, it might be possible to invent a waist-band or a boot-strap by which this apparently impossible feat might be accomplished!

Travelers in Mexico frequently bring home beans which jump about when laid on a table. They are well-known as "jumping beans" and have often been a puzzle to those who were not familiar with the facts in the case. Each bean contains the larva of a species of beetle and this affords a clue to the secret. But the question at once comes up: "How is the insect able to move, not only itself, but its house as well, without some purchase or direct contact with the table?"

The explanation is simple. The hollow bean is elastic and the insect has strength enough to bend it slightly; when the insect suddenly relaxes its effort and allows the bean to spring back to its former shape, the reaction on the table moves the bean. A man placed in a perfectly rigid box could never move himself by pressing on the sides, but if the box were elastic and could be bent by the strength of the man inside, it might be made to move. [129]

A somewhat analogous result, but depending on different principles, is attained in certain curious boat races which are held at some English regattas and which is explained by Prof. W. W. Rouse Ball, in his "Mathematical Recreations and Problems." He says that it

"affords a somewhat curious illustration of the fact that commonly a boat is built so as to make the resistance to motion straight forward less than that to motion in the opposite direction.

"The only thing supplied to the crew is a coil of rope, and they have (without leaving the boat) to propel it from one point to another as rapidly as possible. The motion is given by tying one end of the rope to the afterthwart, and giving the other end a series of violent jerks in a direction parallel to the keel.

"The effect of each jerk is to compress the boat. Left to itself the boat tends to resume its original shape, but the resistance to the motion through the water of the stern is much greater than that of the bow, hence, on the whole, the motion is forwards. I am told that in still water a pace of two or three miles an hour can be thus attained."

## HOW A SPIDER LIFTED A SNAKE

**O**NE of the most interesting books in natural history is a work on "Insect Architecture," by Rennie. But if the architecture of insect homes is wonderful, the engineering displayed by these creatures is equally marvellous. Long before man had thought of the saw, the saw-fly had used the same tool, made after the same fashion, and used in the same way for the purpose of making slits in the branches of trees so that she might have a secure place in which to deposit her eggs. The carpenter bee, with only the tools which nature has given her, cuts a round hole, the full diameter of her body, through thick boards, and so makes a tunnel by which she can have a safe retreat, in which to rear her young. The tumble-bug, without derrick or machinery, rolls over large masses of dirt many times her own weight, and the sexton beetle will, in a few hours, bury beneath the ground the carcass of a comparatively large animal. All these feats require a degree of instinct which in a reasoning creature would be called engineering skill, but none of them are as wonderful as the feats performed by the spider. This extraordinary little animal has the faculty of propelling her threads directly against the wind, and by means of her slender cords she can haul up and suspend bodies which are many times her own weight.

Some years ago a paragraph went the rounds of the papers in which it was said that a spider had suspended an unfortunate mouse, raising it up from the ground, and leaving it to perish miserably between heaven and earth. Would-be philosophers made great fun of this statement, and ridiculed it unmercifully. I know not how true it *was*, but I know that it *might have been* true.

[131]

Some years ago, in the village of Havana, in the State of New York, a spider entangled a milk-snake in her threads, and actually raised it some distance from the ground, and this, too, in spite of the struggles of the reptile, which was alive.

By what process of engineering did the comparatively small and feeble insect succeed in overcoming and lifting up by mechanical means, the mouse or the snake? The solution is easy enough if we only give the question a little thought.

The spider is furnished with one of the most efficient mechanical implements known to engineers, viz., a strong elastic thread. That the thread is strong is well known. Indeed, there are few substances that will support a greater strain than the silk of the silkworm, or the spider; careful experiment having shown that for equal sizes the strength of these fibers exceeds that of common iron. But notwithstanding its strength, the spider's thread alone would be useless as a mechanical power if it were not for its elasticity. The spider has no blocks or pulleys, and, therefore, it cannot cause the thread to divide up and run in different directions, but the elasticity of the thread more than makes up for this, and renders possible the lifting of an animal much heavier than a mouse or a snake. This may require a little explanation.

Let us suppose that a child can lift a six-pound weight one foot high and do this twenty times a minute. Furnish him with 350 rubber bands, each capable of pulling six pounds through one foot when stretched. Let these bands be attached to a wooden platform on which stand a pair of horses weighing 2,100 lbs., or rather more than a ton. If now the child will go to work and stretch these rubber bands, singly, hooking each one up, as it is stretched, in less than twenty minutes he will have raised the pair of horses one foot!

[132]

We thus see that the elasticity of the rubber bands enables the child to divide the weight of the horses into 350 pieces of six pounds each, and at the rate of a little less than one every three seconds, he lifts all these separate pieces one foot, so that the child easily lifts this enormous weight.

Each spider's thread acts like one of the elastic rubber bands. Let us suppose that the mouse or the snake weighed half an ounce and that each thread is capable of supporting a grain and a half. The spider would have to connect the mouse with the point from which it was to be suspended with 150 threads, and if the little quadruped was once swung off his feet, he would be powerless. By pulling successively on each thread and shortening it a little, the mouse or snake might be raised to any height within the capacity of the building or structure in which the work was done. So that to those who have ridiculed the story we may justly say: "There are more things in heaven and earth than are dreamed of in *your* philosophy."

What object the spider could have had in this work I am unable to see. It may have been a dread of the harm which the mouse or snake might work, or it may have been the hope that the decaying carcass would attract flies which would furnish food for the engineer. I can vouch for the truth of the snake story, however, and the object of this article is to explain and render credible a very extraordinary feat of insect engineering.

# THE SUN-DIAL

**I**N the twentieth chapter of II Kings, at the eleventh verse we read, that "Isaiah the prophet cried unto the Lord, and he brought the shadow ten degrees backward, by which it had gone down in the dial of Ahaz."

It is a curious fact, first pointed out by Nonez, the famous cosmographer and mathematician of the sixteenth century, but not generally known, that by tilting a sun-dial through the proper angle, the shadow at certain periods of the year can be made, for a short time, to move backwards on the dial. This was used by the French encyclopædists as a rationalistic explanation of the miracle which is related at the opening of this article.

The reader who is curious in such matters will find directions for constructing "a dial, for any latitude, on which the shadow shall retrograde or move backwards," in Ozanam's "Recreations in Science and Natural Philosophy," Riddle's edition, page 529. Professor Ball in his "Mathematical Recreations," page 214, gives a very clear explanation of the phenomenon. The subject is somewhat too technical for these pages.

---

## HOW A WATCH MAY BE USED AS A COMPASS

[134]

**S**EVERAL years ago a correspondent of "Truth" (London) gave the following simple directions for finding the points of the compass by means of the ordinary pocket watch: "Point the hour hand to the sun, and south is exactly half way between the hour hand and twelve on the watch, counting forward up to noon, but backward after the sun has passed the meridian."

Professor Ball, in his "Mathematical Recreations and Problems," gives more complete directions and explanations. He says:

"The position of the sun relative to the points of the compass determines the solar time. Conversely, if we take the time given by a watch as being the solar time (and it will differ from it only by a few minutes at the most), and we observe the position of the sun, we can find the points of the compass. To do this it is sufficient to point the hour-hand to the sun and then the direction which bisects the angle between the hour and the figure XII will point due south. For instance, if it is four o'clock in the afternoon, it is sufficient to point the hour-hand (which is then at the figure IIII) to the sun, and the figure II on the watch will indicate the direction of south. Again, if it is eight o'clock in the morning, we must point the hour-hand (which is then at the figure VIII) to the sun, and the figure X on the watch gives the south point of the compass.

"Between the hours of six in the morning and six in the evening the angle between the hour and XII, which must be bisected is less than 180 degrees, but at other times the angle to be bisected is greater than 180 degrees; or perhaps it is simpler to say that at other times the rule gives the north point and not the south point.

"The reason is as follows: At noon the sun is due south, and it makes one complete circuit round the points of the compass in 24 hours. The hour-hand of a watch also makes one complete circuit in 12 hours. Hence, if the watch is held with its face in the plane of the ecliptic, and the figure XII on the dial is pointed to the south, both the hour-hand and the sun will be in that direction at noon. Both move round in the same direction, but the angular velocity of the hour-hand is twice as great as that of the sun. Hence the rule. The greatest error due to the neglect of the equation of time is less than 2 degrees. Of course, in practice, most people would hold the face of the watch horizontal, and in our latitude (that of London) no serious error would thus be introduced.

"In the southern hemisphere, or in any tropical country where at noon the sun is due north, the rule will give the north point instead of the south."

[135]

---

## MICROGRAPHY OR MINUTE WRITING AND MICROPHOTOGRAPHY

[136]

MINUTE works of art have always excited the curiosity and commanded the admiration of the average man. Consequently Cicero thought it worth while to record that the entire Iliad of Homer had been written upon parchment in characters so fine that the copy could be enclosed in a



nutshell. This has always been regarded as a marvelous feat.

There is in the French Cabinet of Medals a seal, said to have belonged to Michael Angelo, the fabrication of which must date from a very remote epoch, and upon which fifteen figures have been engraved in a circular space of fourteen millimeters (.55 inch) in diameter. These figures cannot be distinguished by the naked eye.

The Ten Commandments have been engraved in characters so fine that they could be stamped upon one side of a nickle five-cent piece, and on several occasions the Lord's Prayer has been engraved on one side of a gold dollar, the diameter of which is six-tenths of an inch. I have also seen it written with a pen within a circle which measured four-tenths of an inch in diameter.

In the Harleian manuscript, 530, there is an account of a "rare piece of work, brought to pass by Peter Bales, an Englishman, and a clerk of the chancery." D'Israeli tells us that it was "The whole Bible in an English walnut, no bigger than a hen's egg. The nut holdeth the book: there are as many leaves in his little book as in the great Bible, and he hath written as much in one of his little leaves as a great leaf of the Bible."

[137]

By most people, such achievements are considered marvels of skill, and the newspaper accounts of them which are published always attract special attention. And it must be acknowledged that such work requires good eyes, steady nerves, and very delicate control of the muscles. But with ordinary writing materials there are certain mechanical limitations which must prevent even the most skilful from going very far in this direction. These limitations are imposed by the fiber or grain of the paper and the construction of the ordinary pen, neither of which can be carried beyond a certain very moderate degree of fineness. Of course, the paper that is chosen will be selected on account of its hard, even-grained surface, and the pen will be chosen on account of the quality of its material and its shape, and the point is always carefully dressed on a whetstone so as to have both halves of the nib equal in strength and length, and the ends smooth and delicate. When due preparation has been made, and when the eyes and nerves of the writer are in good condition, the smallness of the distinctly readable letters that may be produced is wonderful. And in this connection it is an interesting fact that in many mechanical operations, writing included, the hand is far more delicate than the eye. That which the unaided eye can see to write, the unaided eye can see to read, but the hand, without the assistance or guidance of the eye, can produce writing so minute that the best eyes cannot see to read it, and yet, when viewed under a microscope, it is found to compare favorably with the best writing of ordinary size. And those who are conversant with the more delicate operations of practical mechanics, know that this is no exceptional case. The only aid given by the eye in the case of such minute writing is the arrangement of the lines, otherwise the writing could be done as well with the eyes shut as open.

[138]

Since the mechanical limitations which we have noted prevent us from going very far with the instruments and materials mentioned, the next step is to adopt a finer surface and a sharper point. These conditions may be found in the fine glazed cards and the metal pencils or styles used by card writers. In these cards the surface is nearly homogeneous, that is to say, free from fibers, and the point of the metal pencil may be made as sharp as a needle, but to utilize these conditions to the fullest extent, it is necessary to aid the eye, and a magnifier is, therefore, brought into use. Under a powerful glass the hand may be so guided by the eye that the writing produced cannot be read by the unaided vision.

The specimens of fine writing thus far described have been produced directly by the hand under the guidance either of a magnifier or the simple sense of motion. Just how far it would be possible to go by these means has never been determined, so far as I know, but those who have examined the specimens of selected diatoms and insect scales in which objects that are utterly invisible to the naked eye are arranged with great accuracy so as to form the most beautiful figures, can readily believe that a combination of microscopical dexterity and skill in penmanship might easily go far beyond anything that has yet been accomplished in this direction, either in ancient or modern times.

But by means of a very simple mechanical arrangement, the motion of the hand in every direction may be accurately reduced or enlarged to almost any extent, and it thus becomes possible to form letters which are inconceivably small. The instrument by which this is accomplished is known as a pantagraph, and it has, within a few years, become quite popular as a means of reducing or enlarging pictures of various kinds, including crayon reproductions of photographs. Its construction and use are, therefore, very generally understood. It was by means of a very finely-made instrument embodying the principles of the pantagraph that the extraordinarily fine work which we are about to describe was accomplished.

[139]

It is obvious, however, that in order to produce very fine writing we must use a very fine pen or point and the finer the point the sooner does it wear out, so that in a very short time the lines which go to form the letters become thick and blurred and the work is rendered illegible. As a consequence of this, when the finest specimens of writing are required, it is necessary to abandon the use of ordinary points and surfaces and to resort to the use of the diamond for a pen, and glass for a surface upon which to write. One of the earliest attempts in this direction was that of M. Froment, of Paris, who engraved on glass, within a circle, the one-thirtieth of an inch in diameter, the Coat of Arms of England—lion, unicorn, and crown—with the following inscription, partly in Roman letters, partly in script: "*Honi soit qui mal y pense*, Her Most Gracious Majesty, Queen Victoria, and His Royal Highness, Prince Albert, *Dieu et mon droit*. Written on occasion of the Great Exhibition, by Froment, à Paris, 1851."

The late Dr. Barnard, President of Columbia College, had in his possession a copy of the device borne by the seal of Columbia College, New York, executed for him by M. Dumoulin-Froment, within a circle less than three one-hundredths of an inch in diameter, "in which are embraced four human figures and various other objects, together with inscriptions in Latin, Greek, and Hebrew, all clearly legible. In this device the rising sun is represented in the horizon, the diameter of the disk being about three one-thousandths of an inch. This disk has been cross-hatched by the draughtsman in the original design from which the copy was made; and the copy shows the marks of the cross-hatching with perfect distinctness. When this beautiful and delicate drawing is brought clearly out by a suitably adjusted illumination, the lines appear as if traced by a smooth point in a surface of opaque ice."

[140]

Lardner, in his book on the "Microscope," published in 1856, gives a wood cut which shows the first piece of engraving magnified 120 diameters, but he said that he was not at liberty to describe the method by which it was done. As happens in almost all such cases, however, the very secrecy with which the process was surrounded naturally stimulated others to rival or surpass it, and Mr. N. Peters, a London banker, turned his attention to the subject and soon invented a machine which produced results far exceeding anything that M. Froment had accomplished. On April 25, 1855, Mr. Farrants read before the Microscopical Society of London a full account of the Peters machine, with which the inventor had written the Lord's Prayer (in the ordinary writing character, without abbreviation or contraction of any kind), in a space not exceeding the one hundred and fifty-thousandth of a square inch. Seven years later, Mr. Farrants, as President of the Microscopical Society, described further improvements in the machine of Mr. Peters, and made the following statement: "The Lord's Prayer has been written and may be read in the one-three hundred and fifty-six thousandth of an English square inch. The measurements of one of these specimens was verified by Dr. Bowerbank, with a difference of not more than one five-millionth of an inch, and that difference, small as it is, arose from his not including the prolongation of the letter *f* in the sentence 'deliver us from evil'; so he made the area occupied by the writing less than that stated above."

[141]

Some idea of the minuteness of the characters in these specimens may be obtained from the statement that the whole Bible and Testament, in writing of the same size, might be placed twenty-two times on the surface of a square inch. The grounds for this startling assertion are as follows: "The Bible and Testament together, in the English language, are said to contain 3,566,480 letters. The number of letters in the Lord's Prayer, as written, ending in the sentence, 'deliver us from evil,' is 223, whence, as 3,566,480 divided by 223, is equal to 15,922, it appears that the Bible and Testament together contain the same number of letters as the Lord's Prayer written 16,000 times; if then the prayer were written in  $\frac{1}{16,000}$  of an inch, the Bible and Testament in writing of the same size would be contained by one square inch; but as  $\frac{1}{356,000}$  of an inch is one twenty-second part of  $\frac{1}{15,922}$  of an inch, it follows that the Bible and Testament, in writing of that size, would occupy less space than one twenty-second of a square inch."

It only now remains to be seen that, minute as are the letters written by this machine, they are characterized by a clearness and precision of form which proves that the moving parts of the machine, while possessing the utmost delicacy of freedom, are absolutely destitute of shake, a union of requisites very difficult of fulfilment, but quite indispensable to the satisfactory performance of the apparatus.

[142]

I have no information in regard to the present whereabouts of any of the specimens turned out by Mr. Peters, and inquiry in London, among persons likely to know, has not supplied any information on the subject.

There was, however, another micrographer, Mr. William Webb, of London, who succeeded in producing some marvellous results. Epigrams and also the Lord's Prayer written in the one-thousandth part of a square inch have been freely distributed. Mr. Webb also produced a few copies of the second chapter of the Gospel, according to St. John, written on the scale of the whole Bible, to a little more than three-quarters of a square inch, and of the Lord's Prayer written on the scale of the whole Bible eight times on a square inch. Mr. Webb died about fifteen years ago, and I believe he has had no successor in the art. Specimens of his work are quite scarce, most of them having found their way into the cabinets of public Museums and Societies, who are unwilling to part with them. The late Dr. Woodward, Director of the Army Medical Museum, Washington, D.C., procured two of them on special order for the Museum. Mr. Webb had brought out these fine writings as tests for certain qualities of the microscope, and it was to "serve as tests for high-power objectives" that Dr. Woodward procured the specimens now in the microscopical department of the Museum. I am so fortunate as to have in my possession two specimens of Mr. Webb's work. One is an ordinary microscopical glass slide, three inches by one, and in the center is a square speck which measures  $\frac{1}{45}$ th of an inch on the side. Upon this square is written the whole of the second chapter of the Gospel according to St. John—the chapter which contains the account of the marriage in Cana of Galilee.

[143]

In order to estimate the space which the whole Bible would occupy if written on the same scale as this chapter, I have made the following calculation which, I think, will be more easily followed and checked by my readers, than that of Mr. Farrants.

The text of the old version of the Bible, as published in minion by the American Bible Society, contains 1272 pages, exclusive of title pages and blanks. Each page contains two columns of 58 lines each, making 116 lines to the page. This includes the headings of the chapters and the

synopses of their contents, which are, therefore, thrown in to make good measure. We have, therefore, 1272 pages of 116 lines each, making a total of 147,552 lines.

The second chapter of St. John has 25 verses containing 95 lines, and is written on the 1-2025th of an inch, or, in other words, it would go 2025 times on a square inch. A square inch would, therefore, contain  $95 \times 2025$  or 192,375 lines. This number (192,375), divided by the number of lines in the Bible (147,552), gives 1.307, which is the number of times the Bible might be written on a square inch in letters of the same size. In other words, the whole Bible might be written on .77 inch, or very little more than three-quarters of a square inch.

Perhaps the following gives a more impressive illustration: The United States silver quarter of a dollar is .95 inch in diameter, so that the surface of each side is .707 of a square inch. The whole Bible would, therefore, very nearly go on one side of a quarter of a dollar. If the blank spaces at the heads of the chapters and the synopses of contents were left out, it would easily go on one side.

[144]

The second specimen, which I have of Mr. Webb's writing, is a copy of the Lord's Prayer written on a scale of eight Bibles to the square inch. According to a statement kindly sent me by the superintendent of the United States Mint at Philadelphia, the diameter of the last issued gold dollar, and also of the silver half-dime, is six-tenths of an inch. This gives .2827+ of a square inch as the area of the surface of one side, and, therefore, the whole Bible might be written more than two and a quarter times on one side of either the gold dollar or the silver half dime.

Such numerical and space relations are far beyond the power of any ordinary mind to grasp. With the aid of a microscope we can see the object and compare with other magnifications the rate at which it is enlarged, and a person of even the most ordinary education can follow the calculation and understand why the statements are true, but the final result, like the duration of eternity or the immensity of space, conveys no definite idea to our minds.

But at the same time we must carefully distinguish between our want of power to grasp these ideas and our inability to form a conception of some inconceivable subject, such as a fourth dimension or the mode of action of a new sense.

Wonderful as these achievements are, there is another branch of the microscopic art which, from the practical applications that have been made of it, is even more interesting. This is the art of microphotography.

About the middle of the last century Mr. J. B. Dancer, of Manchester, England, produced certain minute photographs of well-known pictures and statues which commanded the universal attention of the microscopists of that day, and for a time formed the center of attraction at all microscopical exhibitions. They have now, however, become so common that they receive no special notice. Mr. Dancer and other artists also produced copies of the Lord's Prayer, the Creed, the Declaration of Independence, etc., on such a scale that the Lord's Prayer might be covered with the head of a common pin, and yet, when viewed under a very moderate magnifying power, every letter was clear and distinct. I have now before me a slip of glass, three inches long and one inch wide, in the center of which is an oval photograph which occupies less than the 1-200th of a square inch. This photograph contains the Declaration of Independence with the signatures of all the signers, surrounded by portraits of the Presidents and the seals of the original thirteen States. Under a moderate power every line is clear and distinct. In the same way copies of such famous pictures as Landseer's "Stag at Bay," although almost invisible to the naked eye, come out beautifully clear and distinct under the microscope, so that it has been suggested that one might have an extensive picture gallery in a small box, or pack away copies of all the books in the Congressional Library in a small hand-bag. With such means at our command, it would be a simple matter to condense a bulky dispatch into a few little films, which might be carried in a quill or concealed in ways which would have been impossible with the original. If Major André had been able to avail himself of this mode of reducing the bulk of the original papers, he might have carried, without danger of discovery, those reports which caused his capture and led to his death. And hereafter the ordinary methods of searching suspected spies will have to be exchanged for one that is more efficient.

[145]

[146]

The most interesting application of microphotography, of which we have any record, occurred during the Franco-Prussian war in 1870-71.

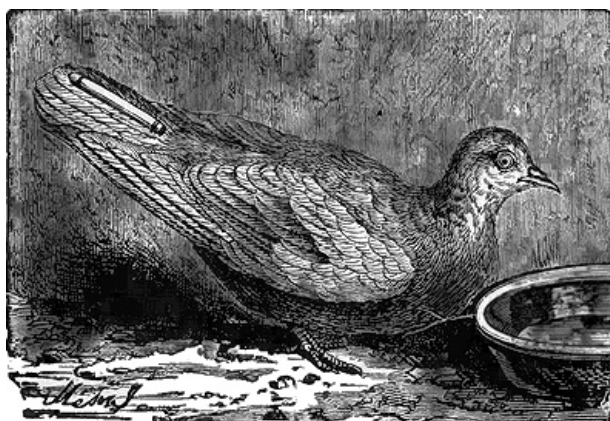



On September 21, 1870, the Germans so completely surrounded the French capitol, that all communication by roads, railways, and telegraphs, was cut off and the only way of escape from the city was through the air. On April 23, the first balloon left Paris, and in a short time after that, a regular balloon post was established, letters and packages being sent out at intervals of three to seven days. In order to get news back to the city, carrier pigeons were employed, and at first the letters were simply written on very thin paper and enclosed in quills which were fastened to the middle tail-feather of the bird, as shown in the engraving, Fig. 21. It is, of course, needless to say, that the ordinary pictures of doves with letters tied round their necks or love-notes attached to their wings, are all mere romance. A bird loaded in that way would soon fall a prey to its enemies. As it was, some of the pigeons were shot by German gunners or captured by hawks trained by the Germans for the purpose, but the great majority got safely through.

[147]

Written communications, however, were of necessity, bulky and heavy, and therefore M. Dagron, a Parisian photographer, suggested that the news be printed in large sheets of which microphotographs could be made and transferred to collodion positives which might then be stripped from the glass and would be very light. This was done; the collodion pellicles measuring about ten centimeters (four inches) square and containing about three thousand average messages. Eighteen of these pellicles weighed less than one gramme (fifteen grains) and were easily carried by a single pigeon. The pigeons having been bred in Paris and sent out by balloons, always returned to their dove-cotes in that city.

M. Dagron left Paris by balloon on November 12, and after a most adventurous voyage, being nearly captured by a German patrol, he reached Tours and there established his headquarters, and organized a regular system of communication with the capitol. The results were most satisfactory, upwards of two and a half millions of messages having been sent into the city. Even postal orders, and drafts were transmitted in this way and duly honored.

And thus through the pigeon-post, aided by microphotography, Paris was enabled to keep in touch with the outer world, and the anxiety of thousands of families was relieved.

[148]

It is not likely, however, that the pigeon-post will ever again come into use for this purpose; our interest in it is now merely historical, for in the next great siege, if we ever have one, the wireless telegraph will no doubt take its place and messages, which no hawks can capture and no guns can destroy, will be sent directly over the heads of the besiegers.

But let us hope and pray, that the savage and unnecessary war which is now being waged in the east will be the last, and that in the near future, two or more of the great nations of the globe will so police the world, that peace on earth and good will toward men will everywhere prevail.

---

## ILLUSIONS OF THE SENSES

[149]



OUR senses have been called the "Five Gateways of Knowledge" because all that we know of the world in which we live reaches the mind, either directly or indirectly, through these avenues. From the "ivory palace," in which she dwells apart, and which we call the skull, the mind sends forth her scouts—sight, hearing, feeling, taste, and smell—bidding them bring in reports of all that is going on around her, and if the information which they furnish should be untrue or distorted, the most dire results might follow. She, therefore, frequently compares the tale that is told by one with the reports from the others, and in this way it is found that under some conditions these reporters are anything but reliable; the stories which they tell are often distorted and untrue, and in some cases their tales have no foundation whatever in fact, but are the "unsubstantial fabric of a vision."

It is, therefore, of the greatest importance to us, that we should find out the points on which these information bearers are most likely to be deceived so that we may guard against the errors into which they would otherwise certainly lead us.

All the senses are liable to be imposed upon under certain conditions. The senses of taste and of smell are frequently the subject of phantom smells and tastes, which are as vivid as the sensations produced by physical causes acting in the regular way. Even those comparatively new senses<sup>[9]</sup> which have been differentiated from the sense of touch and which, with the original five, make up the mystic number seven, are very untrustworthy guides under certain circumstances. Thus we all know how the sense of heat may be deceived by the old experiment of placing one hand in a bowl of cold water and the other in a bowl of hot water, and then, after a few minutes, placing both hands together in a bowl of tepid water; the hand, which has been in the cold water will feel warm, while that which has just been taken from the hot water, will feel quite cold.

[150]

We have all experienced the deceptions to which the sense of hearing exposes us. Who has not heard sounds which had no existence except in our own sensations? And every one is familiar with the illusions to which we are liable when under the influence of a skilful ventriloquist.

Even the sense of touch, which most of us regard as infallible, is liable to gross deception. When we have "felt" anything we are always confident as to its shape, number, hardness, etc., but the following very simple experiment shows that this confidence may be misplaced:



Fig. 22.

Take a large pea or a small marble or bullet and place it on the table or in the palm of the left hand. Then cross the fingers of the right hand as shown in the engraving, Fig. 22, the second finger crossing the first, and place them on the ball, so that the latter may lie between the fingers, as figured in the cut. If the pea or ball be now rolled about, the sensation is apparently that given by two peas under the fingers, and this illusion is so strong that it cannot be dispelled by calling in any of the other senses (the sense of sight for example) as is usually the case under similar circumstances. We may try and try, but it will only be after considerable experience that we shall learn to disregard the apparent impression that there are two balls.

[151]

[152]

The cause of this illusion is readily found. In the ordinary position of the fingers the same ball cannot touch at the same time the exterior sides of two adjoining fingers. When the two fingers are crossed, the conditions are exceptionally changed, but the instinctive interpretation remains the same, unless a frequent repetition of the experiment has overcome the effect of our first education on this point. The experiment, in fact has to be repeated a great number of times to make the illusion become less and less appreciable.

But of all the senses, that of sight is the most liable to error and illusion, as the following simple illustrations will show.



Fig. 23.

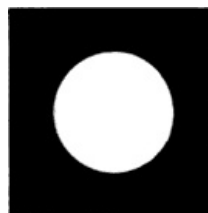

Fig. 24.

In Fig. 23 a black spot has been placed on a white ground, and in Fig. 24 a white spot is placed on a black ground; which is the larger, the black spot or the white one? To every eye the white spot will appear to be the largest, but as a matter of fact they are both the same size. This curious effect is attributed by Helmholtz to what is called irradiation. The eye may also be greatly deceived even in regard to the length of lines placed side by side. Thus, in Fig. 25 a thin vertical line stands upon a thick horizontal one; although the two lines are of precisely the same length, the vertical one seems to be considerably longer than the other.

[153]

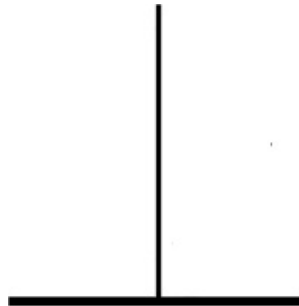

Fig. 25.

In Figs. 26 and 27 a series of vertical and horizontal lines are shown, and in both forms the space that is covered seems to be longer one way than the other. As a matter of fact the space in each case is a perfect square, and the apparent difference in width and height depends upon whether the lines are vertical or horizontal.

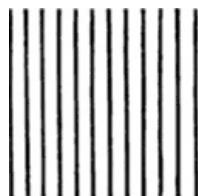

Fig. 26.



Fig. 27.

Advantage is taken of this curious illusion in decorating rooms and in selecting dresses. Stout ladies of taste avoid dress goods having horizontal stripes, and ladies of the opposite conformation avoid those in which the stripes are vertical.

But the greatest discrepancy is seen in Figs. 28 and 29, the middle line in Fig. 29 appearing to be much longer than in Fig. 28. Careful measurement will show that they are both of precisely the same length, the apparent difference being due to the arrangement of the divergent lines at the ends.

[154]

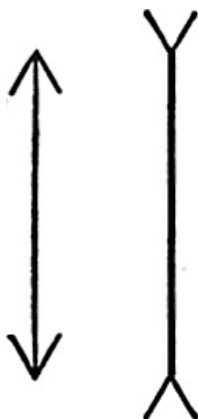

Fig. 28.

Fig. 29.

Converging lines have a curious effect upon apparent size. Thus in Fig. 30 we have a wall and three posts, and if asked which of the posts was the highest, most persons would name C, but measurement will show that A is the highest and that C is the shortest.

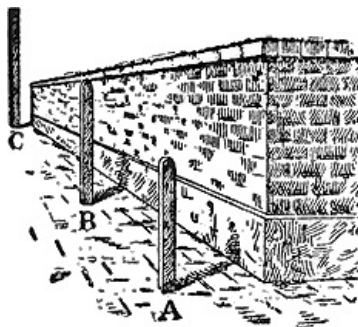

Fig. 30.

A still more striking effect is produced in two parallel lines by crossing them with a series of oblique lines as seen in Figs. 31 and 32. In Fig. 31 the horizontal lines seem to be much closer at the right-hand ends than at the left, but accurate measurement will show that they are strictly parallel.

[155]



Fig. 31.

By changing the direction of the oblique lines, as shown in Fig. 32, the horizontal lines appear to be crooked although they are perfectly straight.

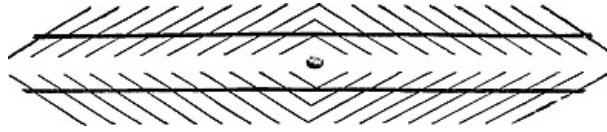

Fig. 32.

All these curious illusions are, however, far surpassed by an experiment which we will now proceed to describe.

FOOTNOTES:

[9] The old and generally recognized list of the senses is as follows: Sight, Hearing, Smell, Taste, and Touch. This is the list enumerated by John Bunyan in his famous work, "The Holie Warre." It has, however, been pointed out that the sense which enables us to recognize heat is not quite the same as that of touch and modern physiologists have therefore set apart, as a distinct sense, the power by which we recognize heat.

The same had been previously done in the case of the sense of Muscular Resistance but, as the author of "The Natural History of Hell" says, "when we differentiate the 'Sense of Heat,' and the 'Sense of Resistance' from the Sense of Touch, we may set up new signposts, but we do not open up any new 'gateways', things still remain as they were of old, and every messenger from the material world around us must enter the ivory palace of the skull through one of the old and well-known ways."

OBJECTS APPARENTLY SEEN THROUGH A HOLE IN THE HAND

[156]



THE following curious experiment always excites surprise, and as I have met with very few persons who have ever heard of it, I republish it from "The Young Scientist," for November, 1880. It throws a good deal of light upon the facts connected with vision.



Fig. 33.

Procure a paste-board tube about seven or eight inches long and an inch or so in diameter, or roll up a strip of any kind of stiff paper so as to form a tube. Holding this tube in the left hand, look through it with the left eye, the right eye also being kept open. Then bring the right hand into the position shown in the engraving, Fig. 33, the edge opposite the thumb being about in line with the right-hand side of the tube. Or the right hand may rest against the right-hand side of the

[157]

tube, near the end farthest from the eye. This cuts off entirely the view of the object by the right eye, yet strange to say the object will still remain apparently visible to both eyes through a hole in the hand, as shown by the dotted lines in the engraving! In other words, it will appear to us as if there was actually a hole through the hand, the object being seen through that hole. The result is startlingly realistic, and forms one of the simplest and most interesting experiments known.

This singular optical illusion is evidently due to the sympathy which exists between the two eyes, from our habit of blending the images formed in both eyes so as to give a single image.

---

## LOOKING THROUGH A SOLID BRICK

[158]



VERY common exhibition by street showmen, and one which never fails to excite surprise and draw a crowd, is the apparatus by which a person is apparently enabled to look through a brick. Mounted on a simple-looking stand are a couple of tubes which look like a telescope cut in two in the middle. Looking through what most people take for a telescope, we are not surprised when we see clearly the people, buildings, trees, etc., beyond it, but this natural expectation is turned into the most startled surprise when it is found that the view of these objects is not cut off by placing a common brick between the two parts of the telescope and directly in the apparent line of vision, as shown in the accompanying illustration, Fig. 34.

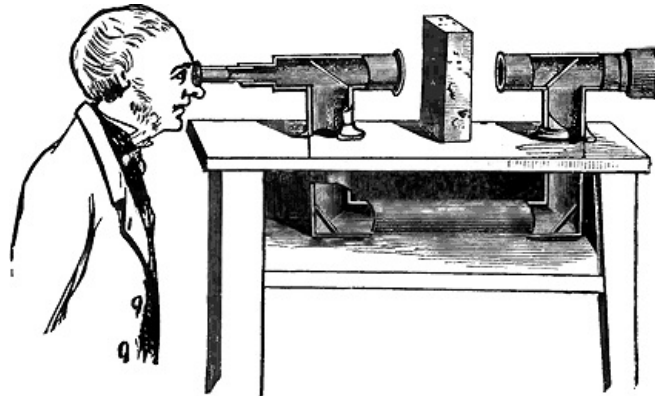

Fig. 34.

In truth, however, the observer looks *round* the brick instead of through it, and this he is enabled to do by means of four mirrors ingeniously arranged as shown in the engraving. As the mirrors and the lower connecting tube are concealed, and the upright tubes supporting the pretended telescope, though hollow, appear to be solid, it is not very easy for those who are not in the secret to discover the trick.

[159]

Of course any number of "fake" explanations are given by the showman who always manages to keep up with the times and exploit the latest mystery. At one time it was psychic force, then Roentgen or X-rays; lately it has been attributed to the mysterious effects of radium!

This illustration is more properly a delusion; there is no illusion about it.

---

## CURIOUS ARITHMETICAL PROBLEMS

[161]

---

## THE CHESS-BOARD PROBLEM

[163]



AN Arabian author, Al Sephadi, relates the following curious anecdote:

A mathematician named Sessa, the son of Dahar, the subject of an Indian Prince, having invented the game of chess, his sovereign was highly pleased with the invention, and wishing to confer on him some reward worthy of his magnificence, desired him to ask whatever he thought proper, assuring him that it should be granted. The mathematician, however, only asked for a grain of wheat for the first square of the chess-board, two for the second, four for the third, and so on to the last, or sixty-fourth. The prince at first was almost

incensed at this demand, conceiving that it was ill-suited to his liberality. By the advice of his courtiers, however, he ordered his vizier to comply with Sessa's request, but the minister was much astonished when, having caused the quantity of wheat necessary to fulfil the prince's order to be calculated, he found that all the grain in the royal granaries, and even all that in those of his subjects and in all Asia, would not be sufficient.

He therefore informed the prince, who sent for the mathematician, and candidly acknowledged that he was not rich enough to be able to comply with his demand, the ingenuity of which astonished him still more than the game he had invented.

It will be found by calculation that the sixty-fourth term of the double progression, beginning with unity, is

9,223,372,036,854,775,808,

and the sum of all the terms of this double progression, beginning with unity, may be obtained by doubling the last term and subtracting the first from the sum. The number, therefore, of the grains of wheat required to satisfy Sessa's demand will be

18,446,744,073,709,551,615.

Now, if a pint contains 9,216 grains of wheat, a gallon will contain 73,728, and a bushel (8 gallons) will contain 589,784. Dividing the number of grains by this quantity, we get 31,274,997,412,295 for the number of bushels necessary to discharge the promise of the Indian prince. And if we suppose that one acre of land is capable of producing in one year, thirty bushels of wheat, it would require 1,042,499,913,743 acres, which is more than eight times the entire surface of the globe; for the diameter of the earth being taken at 7,930 miles, its whole surface, including land and water, will amount to very little more than 126,437,889,177 square acres.

If the price of a bushel of wheat be estimated at one dollar, the value of the above quantity probably exceeds that of all the riches on the earth.

[164]

---

## THE NAIL PROBLEM



**A** GENTLEMAN took a fancy to a horse, and the dealer, to induce him to buy, offered the animal for the value of the twenty-fourth nail in his shoe, reckoning one cent for the first nail, two for the second, four for the third, and so on. The gentleman, thinking the price very low, accepted the offer. What was the price of the horse?

[165]

On calculating, it will be found that the twenty-fourth term of the progression 1, 2, 4, 8, 16, etc., is 8,388,608, or \$83,886.08, a sum which is more than any horse, even the best Arabian, was ever sold for.

Had the price of the horse been fixed at the value of all the nails, the sum would have been double the above price less the first term, or \$167,772.15.

---

## A QUESTION OF POPULATION



**T**HE following note on the result of unrestrained propagation for one hundred generations is taken from "Familiar Lectures on Scientific Subjects," by Sir John F. W. Herschel:

For the benefit of those who discuss the subjects of population, war, pestilence, famine, etc., it may be as well to mention that the number of human beings living at the end of the hundredth generation, commencing from a single pair, doubling at each generation (say in thirty years), and allowing for each man, woman, and child, an average space of four feet in height and one foot square, would form a vertical column, having for its base the whole surface of the earth and sea spread out into a plane, and for its height 3,674 times the sun's distance from the earth! The number of human strata thus piled, one on the other, would amount to 460,790,000,000,000.

In this connection the following facts in regard to the present population of the globe may be of interest:

The present population of the entire globe is estimated by the best statisticians at between fourteen and fifteen hundred millions of persons. This number would easily find standing-room on one half of Long Island, in the State of New York. If this entire population were to be brought to the United States, we could easily give every man, woman, and child, one acre and a half each, or

[166]

a nice little farm of seven acres and a half to every family, consisting of a man, his wife, and three children.

This question has also an important bearing on the preservation of animals which, in limited numbers, are harmless and even desirable. In Australia, where the restraints on increase are slight, the rabbit soon becomes not only a nuisance but a menace, and in this country the migratory thrush or robin, as it is generally called, has been so protected in some localities that it threatens to destroy the small fruit industry.

---

## HOW TO BECOME A MILLIONAIRE

**M**ANY plans have been suggested for getting rich quickly, and some of these are so plausible and alluring that multitudes have been induced to invest in them the savings which had been accumulated by hard labor and severe economy. It is needless to say that, except in the case of a few stool-pigeons, who were allowed to make large profits so that their success might deceive others and lead them into the net, all these projects have led to disaster or ruin. It is a curious fact, however, that some of those who invested in such "get-rich-quickly" schemes were probably fully aware of their fraudulent character and went into the speculation with their eyes open in the hope that *they* might be allowed to become the stool-pigeons, and in this way come out of the enterprise with a large balance on the right side. No regret can be felt when a bird of this kind gets plucked.

[167]

But by the following simple method every one may become his own promoter and in a short time accumulate a respectable fortune. It would seem that almost any one could save one cent for the first day of the month, two cents for the second, four for the third, and so on. Now if you will do this for thirty days we will guarantee you the possession of quite a nice little fortune. See how easy it is to become a millionaire on paper, and by the way, it is only on paper that such schemes ever succeed.

If, however, you should have any doubt in regard to your ability to lay aside the required amount each day, perhaps you can induce some prosperous and avaricious employer to accept the following tempting proposition:

Offer to work for him for a year, provided he pays you one cent for the first week, two cents for the second, four for the third, and so on to the end of the term. Surely your services would increase in value in a corresponding ratio, and many business men would gladly accept your terms. We ourselves have had such a proposition accepted over and over again; the only difficulty was that when we insisted upon security for the last instalment of our wages, our would-be employers could never come to time. And we would strongly urge upon our readers that if they ever make such a bargain, they get full security for the last payment for they will find that when it becomes due there will not be money enough in the whole world to satisfy the claim.

The entire amount of all the money in circulation among all the nations of the world (not the *wealth*) is estimated at somewhat less than \$15,000,000,000, and the last payment would amount to fifteen hundred times that immense sum.

[168]

The French have a proverb that "it is the first step that costs" (*c'est le premier pas qui coute*) but in this case it is the last step that costs and it costs with a vengeance.

While on this subject let me suggest to my readers to figure up the amount of which they will be possessed if they will begin at fifteen years of age and save ten cents per week for sixty years, depositing the money in a savings bank as often as it reaches the amount required for a deposit, and adding the interest every six months. Most persons will be surprised at the result.

---

## THE ACTUAL COST AND PRESENT VALUE OF THE FIRST FOLIO SHAKESPEARE

**S**EVEREN years after the death of Shakespeare, his collected works were published in a large folio volume, now known as "The First Folio Shakespeare." This was in the year 1623. The price at which the volume was originally sold was one pound, but perhaps we ought to take into consideration the fact that at that time money had a value, or purchasing power, at least eight times that which it has at present; Halliwell-Phillips estimates it at from twelve to twenty times its present value. For this circumstance, however, full allowance may be made by multiplying the ultimate result by the proper number.

This folio is regarded as the most valuable printed book in the English language—the last copy that was offered for sale in good condition having brought the record price of nearly \$9,000, so that it is safe to assume that a perfect copy, in the condition in which it left the publisher's hands, would readily command \$10,000, and the question now arises: What would be the comparative value of the present price, \$10,000, and of the original price (one pound) placed at interest and compounded every year since 1623?

[169]

Over and over again I have heard it said that the purchasers of the "First Folio" had made a splendid investment and the same remark is frequently used in reference to the purchase of books in general, irrespective of the present intellectual use that may be made of them. Let us make the comparison.

Money placed at compound interest at six per cent, a little more than doubles itself in twelve years. At the present time and for a few years back, six per cent is a high rate, but it is a very low rate for the average. During a large part of the time money brought eight, ten, and twelve per cent per annum, and even within the half century just past it brought seven per cent during a large portion of the time. Now, between 1623 and 1899, there are 23 periods, of 12 years each, and at double progression the twenty-third term, beginning with unity, would be 8,388,608. This, therefore, would be the amount, in pounds, which the volume had cost up to 1899. In dollars it would be \$40,794,878.88. An article which costs forty millions of dollars, and sells for ten thousand dollars, cannot be called a very good financial investment.

From a literary or intellectual standpoint, however, the subject presents an entirely different aspect.

Some time ago I asked one of the foremost Shakespearian scholars in the world if he had a copy of the "First Folio." His reply was that he could not afford it; that it would not be wise for him to lose \$400 to \$500 per year for the mere sake of ownership, when for a very slight expenditure for time and railway fare he could consult any one of half-a-dozen copies whenever he required to do so.

[170]

---

## ARITHMETICAL PUZZLES



GOOD-SIZED volume might be filled with the various arithmetical puzzles which have been propounded. They range from a method of discovering the number which any one may think of to a solution of the "famous" question: "How old is Ann?" Of the following cases one may be considered a "catch" question, while the other is an interesting problem.

A country woman, carrying eggs to a garrison where she had three guards to pass, sold at the first, half the number she had and half an egg more; at the second, the half of what remained and half an egg more; at the third the half of the remainder and half an egg more; when she arrived at the market-place she had three dozen still to sell. How was this possible without breaking any of the eggs?

At first view, this problem seems impossible, for how can half an egg be sold without breaking any? But by taking the greater half of an odd number we take the exact half and half an egg more. If she had 295 eggs before she came to the first guard, she would there sell 148, leaving her 147. At the next she sold 74, leaving her 73. At the next she sold 37, leaving her three dozen.

[171]

The second problem is as follows: After the Romans had captured Jotopat, Josephus and forty other Jews sought shelter in a cave, but the refugees were so frightened that, with the exception of Josephus himself and one other, they resolved to kill themselves rather than fall into the hands of their enemies. Failing to dissuade them from this horrid purpose, Josephus used his authority as their chief to insist that they put each other to death in an orderly manner. They were therefore arranged round a circle, and every third man was killed until but two men remained, the understanding being that they were to commit suicide. By placing himself and the other man in the 31st and 16th places, they were the last that were left, and in this way they escaped death.

---

## ARCHIMEDES AND HIS FULCRUM



NEXT to that of Euclid, the name of Archimedes is probably that which is the best known of all the mathematicians and mechanics of antiquity, and this is in great part due to the two famous sayings which have been attributed to him, one being "Eureka"—"I have found it," uttered when he discovered the method now universally in use for finding the specific gravity of bodies, and the other being the equally famous dictum which he is



said to have addressed to Hiero, King of Sicily,—“Give me a fulcrum and I will raise the earth from its place.”

That Archimedes, provided he had been immortal, could have carried out his promise, is mathematically certain, but it occurred to Ozanam to calculate the length of time which it would take him to move the earth only one inch, supposing his machine constructed and mathematically perfect; that is to say, without friction, without gravity, and in complete equilibrium, and the following is the result:

[172]

For this purpose we shall suppose that the matter of which the earth is composed weighs 300 pounds per cubic foot, this being about the ascertained average. If the diameter of the earth be 7,930 miles, the whole globe will be found to contain 261,107,411,765 cubic miles, which make 1,423,499,120,882,544,640,000 cubic yards, or 38,434,476,263,828,705,280,000 cubic feet, and allowing 300 pounds to each cubic foot, we shall have 11,530,342,879,148,611,584,000,000 for the weight of the earth in pounds.

Now, we know, by the laws of mechanics, that, whatever be the construction of a machine, the space passed over by the weight, is to that passed over by the moving power, in the reciprocal ratio of the latter to the former. It is known also, that a man can act with an effort equal only to about 30 pounds for eight or ten hours, without intermission, and with a velocity of about 10,000 feet per hour. If then we suppose the machine of Archimedes to be put in motion by means of a crank, and that the force continually applied to it is equal to 30 pounds, then with the velocity of 10,000 feet per hour, to raise the earth one inch the moving power must pass over the space of 384,344,762,638,287,052,800,000 inches; and if this space be divided by 10,000 feet or 120,000 inches, we shall have for a quotient 3,202,873,021,985,725,440, which will be the number of hours required for this motion. But as a year contains 8,766 hours, a century will contain 876,600; and if we divide the above number of hours by the latter, the quotient, 3,653,745,176,803, will be the number of centuries during which it would be necessary to make the crank of the machine continually turn in order to move the earth only one inch. We have omitted the fraction of a century as being of little consequence in a calculation of this kind. The machine is also supposed to be constantly in action, but if it should be worked only eight hours each day, the time required would be three times as long.

[173]

So that while it is true that Archimedes could move the world, the space through which he could have moved it, during his whole life, from infancy to old age, is so small that even if multiplied two hundred million times it could not be measured by even the most delicate of our modern measuring instruments.

There is a modern saying which has become almost as famous amongst English-speaking peoples as is that of Archimedes to the world at large. It is that which Bulwer Lytton puts into the mouth of Richelieu, in his well-known play of that name:

"Beneath the rule of men entirely  
great  
THE PEN IS MIGHTIER THAN THE SWORD."

About thirty years ago it occurred to the writer that these two epigrammatic sayings—that of Archimedes and that of Bulwer Lytton, might be symbolized in an allegorical drawing which would forcibly express the ideas which they contain, and the question immediately arose—Where will Archimedes get his fulcrum and what can he use as a lever?

And the mental answer was: Let the pen be the lever and the printing press the fulcrum, while the sword, used for the same purpose but resting on glory, or in other words, having no substantial fulcrum, breaks in the attempt. The little engraving which, with a new motto, forms a fitting tail-piece to this volume, was the outcome.

[174]

It is true that the pen is mighty, and in the hands of philosophers and diplomats it accomplishes much, but it is only when resting on the printing press that it is provided with that fulcrum which enables it to raise the world by diffusing knowledge, inculcating morality, and providing pleasure and culture for humanity at large.

When assigned to such a task the sword breaks, and well it may. But we have a well-grounded hope that through the influence of the pen and the printing press there will soon come an era of universal



**Peace on Earth and Good Will Toward Men.**

## INDEX

- Absurdities in perpetual motion, [42](#)  
 Accuracy of modern methods of squaring the circle, [17](#)  
 Adams, perpetual motion, [71](#)  
 Ahaz, dial of, [133](#)  
 Air, liquid, [65](#)  
 Alkahest, or universal solvent, [104](#)  
 Altar of Apollo, [30](#)  
 Angelo, Michael, finely engraved seal, [136](#)  
 Angle, Trisection of, [33](#)  
 Apollo, Altar of, [30](#)  
 Approximations to ratio of diameter to circumference of circle, [17](#)  
     De Morgan's Illustration of, [18](#)  
     New Illustration of, [19](#)  
 Archimedean screw, [49](#)  
 Archimedes, area of circle, [13](#)  
     Ratio of circumference to diameter, [14](#)  
 Archimedes and his fulcrum, [171](#)  
 Arithmetic of the ancients, [15](#)  
 Arithmetical problems, [163](#)  
     Chess-board problem, [163](#)  
     Nail problem, [164](#)  
     A question of population, [165](#)  
     How to become a millionaire, [166](#)  
     Cost of first folio Shakespeare, [168](#)  
     Arithmetical puzzles, [170](#)  
     Archimedes and his fulcrum, [171](#)  
 Army Medical Museum, [142](#)
- Ball, Prof. W. W. R., [39](#), [129](#), [133](#), [134](#)  
 Balloons for conveying letters, [147](#)  
 Balls—proportion of weight to diameter, [32](#)  
 Bean, jumping, [128](#)  
 Bells kept ringing for eight years, [41](#)  
 Bible in walnut shell, [136](#)  
 Bible, written at rate of 22 to square inch, [141](#)  
 Boat-race without oars, [129](#)  
 Bolognian phosphorus, [102](#)  
 Boots—lifting oneself by straps of, [128](#)  
 Boyle and palingenesis, [107](#)  
 Bramwell, Sir Frederick, [38](#)  
 Brick, to look through, [151](#)  
 Buckle and geometrical lines, [119](#)  
 "Budget of Paradoxes," De Morgan, [6](#), [18](#), [118](#)
- Carbon bisulphide for perpetual motion, [67](#)  
 Capillary attraction, [53](#)  
 Carpenter, Edward—fourth dimension, [122](#)  
 Catherine II, [118](#)  
 "Century of Inventions," [74](#)  
 Chess-board problem, [163](#)  
 Child lifting two horses, [131](#)  
     Perpetual motion by a, [64](#)  
 Circle, squaring the, [9](#)  
     Supposed reward for squaring the, [9](#)  
     Resolution of Royal Academy of Sciences on, [10](#)  
     What the problem is, [12](#)  
     Approximation to, by Archimedes, [14](#)  
     Jews, ratio accepted by, [13](#)  
     Egyptians, ratio accepted by, [14](#)  
     Symbol for ratio introduced by Euler, [14](#)  
     Graphical approximations, [22](#)  
 Circumference of circle, to find, when diameter is given, [22](#)  
 Clock that requires no winding, [38](#)  
 Columbia College seal, [140](#)  
 Column of De Luc, [40](#)  
 Compass, watch used as a, [134](#)  
 Congreve, Sir William, [53](#)  
 Cube, duplication of, [38](#)

- Crystallization seen by microscope, 108  
 Mistaken for palingenesy, 100
- Dancer—microphotographs, 144  
 Dangerous, fascination of the, 1  
 Declaration of Independence, 145  
 De Luc's column, 40  
 De Morgan—Legend of Michael Scott, 6  
 Ignorance *v.* learning, 8  
 Illustration of accuracy of modern attempts to square the circle, 18  
 "Budget of Paradoxes," 6, 18  
 Trisection of angle, 34, 118  
 On powder of sympathy, 112  
 Anecdote of Diderot, 118
- Dial of Ahaz, 133  
 Diderot, anecdote of, 118  
 Digby, Sir Kenelm, and palingenesy, 109  
 Sir Kenelm and powder of sympathy, 111  
 Dircks, 56, 71, 75  
 Discoveries, valuable, not due to perpetual-motion-mongers, 36  
 Duplication of the cube, 30
- Elixir of life, 95  
 Engineering, insect, 130  
 Euler, 14, 118
- Fallacies in perpetual motion, 65  
 Falstaff and the philosopher's stone, 97  
 Faraday's discovery, 93  
 Farrants, Prest. Royal Mic. Soc, 140  
 Figure, a, enlarged by cutting, 126  
 First folio Shakespeare, cost of, 168  
 Fixation of mercury, 92  
 Follies of Science, The Seven, 2  
 D'Israeli's list, 2  
 An inappropriate term, 3  
 Fourth dimension—conception of, 117  
 Flatland, 120  
 Kant and Gauss, 121  
 Spiritualists, 121  
 Edward Carpenter on, 122  
 Possibility of a new sense, 123  
 Frauds in perpetual motion, 69  
 Freezing of mercury, 93  
 Froment, micrographs, 139
- Gases, liquefaction of, 93  
 Geiser's clock, 71  
 Geometrical quadrature impossible, 21  
 Gibberish, origin of word, 96  
 God, demonstration of existence of, 118
- Hammer made of solid mercury, 93  
 Hand, to look through, 156  
 Heat and cold, illusions, 150  
 Hesse, Landgrave of, 77  
 Hindoos, ratio accepted by, 16  
 Holmes, O. W., and powder of sympathy, 111  
 Homer's Iliad in nutshell, 136  
 Honecourt, Wilars de, 42  
 Horses lifted by child, 131  
 Hydrofluoric acid, 104  
 Hydrostatic paradox, 46
- Iliad of Homer in nutshell, 136  
 Impossible, fascination of the, 1  
 Insect engineering, 130  
 Irradiation, 152
- Jews, ratio accepted by the, 13
- Keeley gold cure, 97  
 Keeley motor, 69  
 Kircher and palingenesy, 106
- Lacomme, on squaring circle, 27

Lamps, ever-burning, [100](#)  
Library, Congressional, in hand-bag, [145](#)  
Light from electric earth-currents, [103](#)  
Lines, geometrical, [119](#)  
Lines, direction of, deceptive, [154](#)  
    Length of, deceptive, [153](#)  
Liquid air, [65](#)  
Lodge, Sir Oliver, on conservation of energy, [5](#)  
Longitude, relation of squaring the circle to, [10](#)

McArthur, on arithmetic of ancients, [15](#)  
Machin, [16](#)  
Magnetism for perpetual motion, [61](#)  
Man lifting himself, [128](#)  
Mathematicians—how they go to heaven, [8](#)  
Mercury, fixation of, [92](#)  
    Freezing of, [93](#)  
Metals. See *Transmutation*.  
Metius, Peter, [16](#)

Micrography, or minute writing, [136](#)  
    Homer in a nutshell, [136](#)  
    Michael Angelo's seal, [136](#)  
    Ten Commandments, [136](#)  
    Bible in a nutshell, [136](#)  
    Earliest micrographic engraving, [139](#)  
    Micrographic copy of seal of Columbia College, [139](#)  
    Peters' machine, [141](#)  
    Lord's Prayer written at rate of 22 Bibles to square inch, [141](#)  
    Webb's fine writing, [142](#)  
    Calculation in regard to, [143](#)  
    Microphotographs by Dancer, [144](#)  
    Pigeon-post in Franco-Prussian War, [146](#)

Millionaire, to become a, [166](#)  
Miracle—dial of Ahaz, [133](#)  
Morgan. See *De Morgan*.  
Morton, President Henry, [66](#)  
Motion, perpetual. See *Perpetual motion*.  
Muir, Prof. On Archimedes, [14](#)  
Musitanus, Carolus, [96](#)

Nail problem, [164](#)  
Nicomedean line, [29](#)

Orffyreus—his real name, [77](#)  
    His fraudulent machine, [77](#)  
Overbalancing wheels, [43](#)

Paint, luminous, [102](#)  
Palingenesy, [106](#)  
Patent office U. S. and perpetual motion, [42](#)  
Pen mightier than the sword, [173](#)  
Perpetual lamps, [100](#)  
Perpetual motion, [36](#)  
    What the problem is, [37](#)  
    Clock that requires no winding, [38](#)  
    Watch wound by walking, [39](#)  
    Clock wound by tides, [41](#)  
    By electricity, [41](#)  
    Absurdities, [42](#)  
    Overbalancing wheels, [43](#)  
    Dr. Young, on, [44](#)  
    Bellows action, [45](#)  
    Hydrostatic paradox, [46](#)  
    Bishop Wilkins, [48](#)  
    Archimedean screw, [49](#)  
    Archimedean screw, by mercury, [51](#)  
    Congreve's, by capillary attraction, [53](#)  
    Tube and balls, [56](#)  
    Tube and rope, [59](#)  
    Magnetism, [61](#)  
    Self-moving railway carriage, [63](#)  
    A child's perpetual motion, [64](#)  
    Fallacies, [65](#)  
    Liquid air, [65](#)  
    Bisulphide of carbon, [66](#)

Frauds, 69  
 Keeley motor, 69  
 Geiser's clock, 71  
 Adams, 71  
 Redhoeffler, 72  
 Lukens, 72  
 How to stop the machine, 73  
 Marquis of Worcester, 74  
 Dircks' model, 75  
 Orffyreus, 77  
 Possibility of, 78  
 Peters' micrographs, 141  
 Philosopher's stone, 97  
 Phosphorus, discovery of, 101  
 Pigeon-post, 146  
 Population, a question of, 165  
 Power, the, of the future, 40  
 Ptolemy, on the circle, 15  
 Puzzles, arithmetical, 170  
  
 Railway carriage, self-moving, 63  
 Ramsay, Sir William, 80, 98  
 Ratio of diameter to circumference carried to 127 places, 17  
 Redhoeffler's perpetual motion, 72  
 Rosicrucius, 100  
 Rutherford, 16  
  
 Schott, Father, and palingenesy, 107  
 Schweirs, Dr., 52  
 Scott, Michael, and his slave demons, 6  
 Scott, Sir Walter, legend of the great Wizard, 6  
     Powder of sympathy, 112  
 Self-moving railway carriage, 63  
 Senses—illusions of, 148  
     Taste and smell, 149  
     Heat and cold, 150  
     Hearing, 150  
     Touch, 150  
     Sight—size of spot, 152  
         Length of lines, 153  
         Direction of lines, 154  
     Objects seen through hand, 156  
     Looking through a brick, 158  
 Sense, possibility of a new, 123  
 Shadow going backward on dial, 133  
 Shakespeare, cost of first folio, 168  
     Philosopher's stone, 97  
     Witchcraft, 114  
 Shanks—value of ratio carried to 707 places, 16  
 Sharp, Abraham, 16  
 Sight, sense of, deceived, 152  
 Smith, James, on squaring circle, 28  
 Snake lifted by spider, 130  
 Solvent, universal, 104  
 Space enlarged by cutting, 126  
 Spider lifting a snake, 130  
 Sun-dial—shadow going backward, 133  
  
 Taste and smell—illusions, 149  
 Tides, clock moved by, 40  
     Will be the great source of power of the future, 40  
 Time it would take Archimedes to move the world, 171  
 Touch, sense of, deceived, 150  
 Transmutation of the metals, 79  
     Ancient fables, 79  
     Hermes Trismegistus, 80  
     Treatises not allegorical, 81  
     Seven metals, 82  
     Metals named after planets, 82  
     Methods of cheating, 83  
     "Brief of the Golden Calf," 84  
     Story of unknown Italian, 87  
     Possibility of effecting, 88  
     Sir William Ramsay, 89  
     Effect of such discovery on our currency system, 90

"Tribune," New York, [29](#)  
Trisection of angle, [33](#)  
Tube and balls, [56](#)  
Tube and rope, [59](#)

Universal medicine. See [Elixir of Life](#).

Van Ceulen, Rudolph, [16](#)

Wallich, Dr., [35](#)

Watch that is wound by walking, [39](#)  
Used as a compass, [134](#)

Webb micrographs, [142](#)

Whewell's refutation of  $3\frac{1}{8}$  ratio, [28](#)

Wilkins, Bishop, [48](#)

Witchcraft or magic, [113](#)

Worcester, Marquis of, [74](#)

Writing, fine, [139](#)

Young, Dr. Thomas, [44](#)

<p><b>Transcriber's Note:</b> Minor spelling and typographical errors have been corrected without note.</p>
---

\*\*\* END OF THE PROJECT GUTENBERG EBOOK THE SEVEN FOLLIES OF SCIENCE [2ND ED.]  
\*\*\*

Updated editions will replace the previous one—the old editions will be renamed.

Creating the works from print editions not protected by U.S. copyright law means that no one owns a United States copyright in these works, so the Foundation (and you!) can copy and distribute it in the United States without permission and without paying copyright royalties. Special rules, set forth in the General Terms of Use part of this license, apply to copying and distributing Project Gutenberg™ electronic works to protect the PROJECT GUTENBERG™ concept and trademark. Project Gutenberg is a registered trademark, and may not be used if you charge for an eBook, except by following the terms of the trademark license, including paying royalties for use of the Project Gutenberg trademark. If you do not charge anything for copies of this eBook, complying with the trademark license is very easy. You may use this eBook for nearly any purpose such as creation of derivative works, reports, performances and research. Project Gutenberg eBooks may be modified and printed and given away—you may do practically ANYTHING in the United States with eBooks not protected by U.S. copyright law. Redistribution is subject to the trademark license, especially commercial redistribution.

## START: FULL LICENSE

### THE FULL PROJECT GUTENBERG LICENSE

PLEASE READ THIS BEFORE YOU DISTRIBUTE OR USE THIS WORK

To protect the Project Gutenberg™ mission of promoting the free distribution of electronic works, by using or distributing this work (or any other work associated in any way with the phrase “Project Gutenberg”), you agree to comply with all the terms of the Full Project Gutenberg™ License available with this file or online at [www.gutenberg.org/license](http://www.gutenberg.org/license).

#### **Section 1. General Terms of Use and Redistributing Project Gutenberg™ electronic works**

1.A. By reading or using any part of this Project Gutenberg™ electronic work, you indicate that you have read, understand, agree to and accept all the terms of this license and intellectual property (trademark/copyright) agreement. If you do not agree to abide by all the terms of this agreement, you must cease using and return or destroy all copies of Project Gutenberg™ electronic works in your possession. If you paid a fee for obtaining a copy of or access to a Project Gutenberg™ electronic work and you do not agree to be bound by the terms of this agreement, you may obtain a refund from the person or entity to whom you paid the fee as set forth in paragraph 1.E.8.

1.B. “Project Gutenberg” is a registered trademark. It may only be used on or associated in any way with an electronic work by people who agree to be bound by the terms of this

agreement. There are a few things that you can do with most Project Gutenberg™ electronic works even without complying with the full terms of this agreement. See paragraph 1.C below. There are a lot of things you can do with Project Gutenberg™ electronic works if you follow the terms of this agreement and help preserve free future access to Project Gutenberg™ electronic works. See paragraph 1.E below.

1.C. The Project Gutenberg Literary Archive Foundation (“the Foundation” or PGLAF), owns a compilation copyright in the collection of Project Gutenberg™ electronic works. Nearly all the individual works in the collection are in the public domain in the United States. If an individual work is unprotected by copyright law in the United States and you are located in the United States, we do not claim a right to prevent you from copying, distributing, performing, displaying or creating derivative works based on the work as long as all references to Project Gutenberg are removed. Of course, we hope that you will support the Project Gutenberg™ mission of promoting free access to electronic works by freely sharing Project Gutenberg™ works in compliance with the terms of this agreement for keeping the Project Gutenberg™ name associated with the work. You can easily comply with the terms of this agreement by keeping this work in the same format with its attached full Project Gutenberg™ License when you share it without charge with others.

1.D. The copyright laws of the place where you are located also govern what you can do with this work. Copyright laws in most countries are in a constant state of change. If you are outside the United States, check the laws of your country in addition to the terms of this agreement before downloading, copying, displaying, performing, distributing or creating derivative works based on this work or any other Project Gutenberg™ work. The Foundation makes no representations concerning the copyright status of any work in any country other than the United States.

1.E. Unless you have removed all references to Project Gutenberg:

1.E.1. The following sentence, with active links to, or other immediate access to, the full Project Gutenberg™ License must appear prominently whenever any copy of a Project Gutenberg™ work (any work on which the phrase “Project Gutenberg” appears, or with which the phrase “Project Gutenberg” is associated) is accessed, displayed, performed, viewed, copied or distributed:

This eBook is for the use of anyone anywhere in the United States and most other parts of the world at no cost and with almost no restrictions whatsoever. You may copy it, give it away or re-use it under the terms of the Project Gutenberg License included with this eBook or online at [www.gutenberg.org](http://www.gutenberg.org). If you are not located in the United States, you will have to check the laws of the country where you are located before using this eBook.

1.E.2. If an individual Project Gutenberg™ electronic work is derived from texts not protected by U.S. copyright law (does not contain a notice indicating that it is posted with permission of the copyright holder), the work can be copied and distributed to anyone in the United States without paying any fees or charges. If you are redistributing or providing access to a work with the phrase “Project Gutenberg” associated with or appearing on the work, you must comply either with the requirements of paragraphs 1.E.1 through 1.E.7 or obtain permission for the use of the work and the Project Gutenberg™ trademark as set forth in paragraphs 1.E.8 or 1.E.9.

1.E.3. If an individual Project Gutenberg™ electronic work is posted with the permission of the copyright holder, your use and distribution must comply with both paragraphs 1.E.1 through 1.E.7 and any additional terms imposed by the copyright holder. Additional terms will be linked to the Project Gutenberg™ License for all works posted with the permission of the copyright holder found at the beginning of this work.

1.E.4. Do not unlink or detach or remove the full Project Gutenberg™ License terms from this work, or any files containing a part of this work or any other work associated with Project Gutenberg™.

1.E.5. Do not copy, display, perform, distribute or redistribute this electronic work, or any part of this electronic work, without prominently displaying the sentence set forth in paragraph 1.E.1 with active links or immediate access to the full terms of the Project Gutenberg™ License.

1.E.6. You may convert to and distribute this work in any binary, compressed, marked up, nonproprietary or proprietary form, including any word processing or hypertext form. However, if you provide access to or distribute copies of a Project Gutenberg™ work in a format other than “Plain Vanilla ASCII” or other format used in the official version posted on the official Project Gutenberg™ website ([www.gutenberg.org](http://www.gutenberg.org)), you must, at no additional cost, fee or expense to the user, provide a copy, a means of exporting a copy, or a means of obtaining a copy upon request, of the work in its original “Plain Vanilla ASCII” or other form. Any alternate format must include the full Project Gutenberg™ License as specified in paragraph 1.E.1.

1.E.7. Do not charge a fee for access to, viewing, displaying, performing, copying or distributing any Project Gutenberg™ works unless you comply with paragraph 1.E.8 or 1.E.9.

1.E.8. You may charge a reasonable fee for copies of or providing access to or distributing Project Gutenberg™ electronic works provided that:

- You pay a royalty fee of 20% of the gross profits you derive from the use of Project Gutenberg™ works calculated using the method you already use to calculate your applicable taxes. The fee is owed to the owner of the Project Gutenberg™ trademark, but he has agreed to donate royalties under this paragraph to the Project Gutenberg Literary Archive Foundation. Royalty payments must be paid within 60 days following each date on which you prepare (or are legally required to prepare) your periodic tax returns. Royalty payments should be clearly marked as such and sent to the Project Gutenberg Literary Archive Foundation at the address specified in Section 4, "Information about donations to the Project Gutenberg Literary Archive Foundation."
- You provide a full refund of any money paid by a user who notifies you in writing (or by e-mail) within 30 days of receipt that s/he does not agree to the terms of the full Project Gutenberg™ License. You must require such a user to return or destroy all copies of the works possessed in a physical medium and discontinue all use of and all access to other copies of Project Gutenberg™ works.
- You provide, in accordance with paragraph 1.F.3, a full refund of any money paid for a work or a replacement copy, if a defect in the electronic work is discovered and reported to you within 90 days of receipt of the work.
- You comply with all other terms of this agreement for free distribution of Project Gutenberg™ works.

1.E.9. If you wish to charge a fee or distribute a Project Gutenberg™ electronic work or group of works on different terms than are set forth in this agreement, you must obtain permission in writing from the Project Gutenberg Literary Archive Foundation, the manager of the Project Gutenberg™ trademark. Contact the Foundation as set forth in Section 3 below.

1.F.

1.F.1. Project Gutenberg volunteers and employees expend considerable effort to identify, do copyright research on, transcribe and proofread works not protected by U.S. copyright law in creating the Project Gutenberg™ collection. Despite these efforts, Project Gutenberg™ electronic works, and the medium on which they may be stored, may contain "Defects," such as, but not limited to, incomplete, inaccurate or corrupt data, transcription errors, a copyright or other intellectual property infringement, a defective or damaged disk or other medium, a computer virus, or computer codes that damage or cannot be read by your equipment.

1.F.2. LIMITED WARRANTY, DISCLAIMER OF DAMAGES - Except for the "Right of Replacement or Refund" described in paragraph 1.F.3, the Project Gutenberg Literary Archive Foundation, the owner of the Project Gutenberg™ trademark, and any other party distributing a Project Gutenberg™ electronic work under this agreement, disclaim all liability to you for damages, costs and expenses, including legal fees. YOU AGREE THAT YOU HAVE NO REMEDIES FOR NEGLIGENCE, STRICT LIABILITY, BREACH OF WARRANTY OR BREACH OF CONTRACT EXCEPT THOSE PROVIDED IN PARAGRAPH 1.F.3. YOU AGREE THAT THE FOUNDATION, THE TRADEMARK OWNER, AND ANY DISTRIBUTOR UNDER THIS AGREEMENT WILL NOT BE LIABLE TO YOU FOR ACTUAL, DIRECT, INDIRECT, CONSEQUENTIAL, PUNITIVE OR INCIDENTAL DAMAGES EVEN IF YOU GIVE NOTICE OF THE POSSIBILITY OF SUCH DAMAGE.

1.F.3. LIMITED RIGHT OF REPLACEMENT OR REFUND - If you discover a defect in this electronic work within 90 days of receiving it, you can receive a refund of the money (if any) you paid for it by sending a written explanation to the person you received the work from. If you received the work on a physical medium, you must return the medium with your written explanation. The person or entity that provided you with the defective work may elect to provide a replacement copy in lieu of a refund. If you received the work electronically, the person or entity providing it to you may choose to give you a second opportunity to receive the work electronically in lieu of a refund. If the second copy is also defective, you may demand a refund in writing without further opportunities to fix the problem.

1.F.4. Except for the limited right of replacement or refund set forth in paragraph 1.F.3, this work is provided to you 'AS-IS', WITH NO OTHER WARRANTIES OF ANY KIND, EXPRESS OR IMPLIED, INCLUDING BUT NOT LIMITED TO WARRANTIES OF MERCHANTABILITY OR FITNESS FOR ANY PURPOSE.

1.F.5. Some states do not allow disclaimers of certain implied warranties or the exclusion or limitation of certain types of damages. If any disclaimer or limitation set forth in this agreement violates the law of the state applicable to this agreement, the agreement shall be



interpreted to make the maximum disclaimer or limitation permitted by the applicable state law. The invalidity or unenforceability of any provision of this agreement shall not void the remaining provisions.

1.F.6. INDEMNITY - You agree to indemnify and hold the Foundation, the trademark owner, any agent or employee of the Foundation, anyone providing copies of Project Gutenberg™ electronic works in accordance with this agreement, and any volunteers associated with the production, promotion and distribution of Project Gutenberg™ electronic works, harmless from all liability, costs and expenses, including legal fees, that arise directly or indirectly from any of the following which you do or cause to occur: (a) distribution of this or any Project Gutenberg™ work, (b) alteration, modification, or additions or deletions to any Project Gutenberg™ work, and (c) any Defect you cause.

## **Section 2. Information about the Mission of Project Gutenberg™**

Project Gutenberg™ is synonymous with the free distribution of electronic works in formats readable by the widest variety of computers including obsolete, old, middle-aged and new computers. It exists because of the efforts of hundreds of volunteers and donations from people in all walks of life.

Volunteers and financial support to provide volunteers with the assistance they need are critical to reaching Project Gutenberg™'s goals and ensuring that the Project Gutenberg™ collection will remain freely available for generations to come. In 2001, the Project Gutenberg Literary Archive Foundation was created to provide a secure and permanent future for Project Gutenberg™ and future generations. To learn more about the Project Gutenberg Literary Archive Foundation and how your efforts and donations can help, see Sections 3 and 4 and the Foundation information page at [www.gutenberg.org](http://www.gutenberg.org).

## **Section 3. Information about the Project Gutenberg Literary Archive Foundation**

The Project Gutenberg Literary Archive Foundation is a non-profit 501(c)(3) educational corporation organized under the laws of the state of Mississippi and granted tax exempt status by the Internal Revenue Service. The Foundation's EIN or federal tax identification number is 64-6221541. Contributions to the Project Gutenberg Literary Archive Foundation are tax deductible to the full extent permitted by U.S. federal laws and your state's laws.

The Foundation's business office is located at 809 North 1500 West, Salt Lake City, UT 84116, (801) 596-1887. Email contact links and up to date contact information can be found at the Foundation's website and official page at [www.gutenberg.org/contact](http://www.gutenberg.org/contact)

## **Section 4. Information about Donations to the Project Gutenberg Literary Archive Foundation**

Project Gutenberg™ depends upon and cannot survive without widespread public support and donations to carry out its mission of increasing the number of public domain and licensed works that can be freely distributed in machine-readable form accessible by the widest array of equipment including outdated equipment. Many small donations (\$1 to \$5,000) are particularly important to maintaining tax exempt status with the IRS.

The Foundation is committed to complying with the laws regulating charities and charitable donations in all 50 states of the United States. Compliance requirements are not uniform and it takes a considerable effort, much paperwork and many fees to meet and keep up with these requirements. We do not solicit donations in locations where we have not received written confirmation of compliance. To SEND DONATIONS or determine the status of compliance for any particular state visit [www.gutenberg.org/donate](http://www.gutenberg.org/donate).

While we cannot and do not solicit contributions from states where we have not met the solicitation requirements, we know of no prohibition against accepting unsolicited donations from donors in such states who approach us with offers to donate.

International donations are gratefully accepted, but we cannot make any statements concerning tax treatment of donations received from outside the United States. U.S. laws alone swamp our small staff.

Please check the Project Gutenberg web pages for current donation methods and addresses. Donations are accepted in a number of other ways including checks, online payments and credit card donations. To donate, please visit: [www.gutenberg.org/donate](http://www.gutenberg.org/donate)

## **Section 5. General Information About Project Gutenberg™ electronic works**

Professor Michael S. Hart was the originator of the Project Gutenberg™ concept of a library of electronic works that could be freely shared with anyone. For forty years, he produced and distributed Project Gutenberg™ eBooks with only a loose network of volunteer support.

Project Gutenberg™ eBooks are often created from several printed editions, all of which are confirmed as not protected by copyright in the U.S. unless a copyright notice is included. Thus, we do not necessarily keep eBooks in compliance with any particular paper edition.

Most people start at our website which has the main PG search facility: [www.gutenberg.org](http://www.gutenberg.org).

This website includes information about Project Gutenberg™, including how to make donations to the Project Gutenberg Literary Archive Foundation, how to help produce our new eBooks, and how to subscribe to our email newsletter to hear about new eBooks.