

The Project Gutenberg eBook of Conversations on Natural Philosophy, in which the Elements of that Science are Familiarly Explained, by Thomas P. Jones and Mrs. Marcet

This ebook is for the use of anyone anywhere in the United States and most other parts of the world at no cost and with almost no restrictions whatsoever. You may copy it, give it away or re-use it under the terms of the Project Gutenberg License included with this ebook or online at www.gutenberg.org. If you are not located in the United States, you'll have to check the laws of the country where you are located before using this eBook.

Title: Conversations on Natural Philosophy, in which the Elements of that Science are Familiarly Explained

Author: Thomas P. Jones

Author: Mrs. Marcet

Release date: July 10, 2011 [EBook #36691]

Language: English

*** START OF THE PROJECT GUTENBERG EBOOK CONVERSATIONS ON NATURAL PHILOSOPHY, IN WHICH THE ELEMENTS OF THAT SCIENCE ARE FAMILIARLY EXPLAINED ***

E-text prepared by Marilynda Fraser-Cunliffe, Stephen H. Sentoff,
and the Online Distributed Proofreading Team
(<http://www.pgdp.net>)

**CONVERSATIONS
ON
NATURAL PHILOSOPHY,

IN WHICH
THE ELEMENTS OF THAT SCIENCE
ARE FAMILIARLY EXPLAINED.**

[Pg i]

Illustrated with Plates.

BY THE AUTHOR OF CONVERSATIONS ON CHEMISTRY, &c.

**WITH CORRECTIONS, IMPROVEMENTS, AND CONSIDERABLE
ADDITIONS IN THE BODY OF THE WORK;**

Appropriate Questions, and a Glossary:

**BY DR. THOMAS P. JONES,
PROFESSOR OF MECHANICS, IN THE FRANKLIN
INSTITUTE OF THE STATE OF PENNSYLVANIA.**

Eastern District of Pennsylvania, to wit:

[Pg ii]

Be it remembered, that, on the twenty-fourth day of April, in the Fiftieth year of the Independence of the United States of America, A. D. 1826, John Grigg, of the said District, hath deposited in this office the title of a book, the right whereof he claims as proprietor, in the words following, to wit:

"Conversations on Natural Philosophy, in which the Elements of that Science are familiarly explained. Illustrated with Plates. By the Author of Conversations on Chemistry, &c. With Corrections, Improvements, and considerable Additions, in the Body of the Work; appropriate Questions, and a Glossary: By Dr. Thomas P. Jones, Professor of Mechanics, in the Franklin Institute, of the State of Pennsylvania."

In conformity to the Act of the Congress of the United States, entitled "An Act for the Encouragement of Learning, by securing the Copies of Maps, Charts, and Books, to the Authors and Proprietors of such Copies, during the times therein mentioned;"—And also to the Act, entitled, "An Act supplementary to an Act, entitled, 'An Act for the Encouragement of Learning, by securing the Copies of Maps, Charts, and Books, to the Authors and Proprietors of such Copies during the times therein mentioned,' and extending the benefits thereof to the arts of designing, engraving, and etching, historical and other prints."

D. CALDWELL,
Clerk of the Eastern District of Pennsylvania.

PREFACE.

[Pg iii]

Notwithstanding the great number of books which are written, expressly for the use of schools, and which embrace every subject on which instruction is given, it is a lamentable fact, that the catalogue of those which are well adapted to the intended purpose, is a very short one. Almost all of them have been written, either by those who are without experience as teachers, or by teachers, deficient in a competent knowledge of the subjects, on which they treat. Every intelligent person, who has devoted himself to the instruction of youth, must have felt and deplored, the truth of these observations.

In most instances, the improvement of a work already in use, will be more acceptable, than one of equal merit would be, which is entirely new; the introduction of a book into schools, being always attended with some difficulty.

The "Conversations on Chemistry," written by Mrs. Marcet, had obtained a well-merited celebrity, and was very extensively adopted as a school-book, before the publication of her "Conversations on Natural Philosophy." This, also, has been much used for the same purpose; but, the observation has been very general, among intelligent teachers, that, in its execution, it is very inferior to the former work.

The editor of the edition now presented to the public, had undertaken to add to the work, questions, for the examination of learners; and notes, where he deemed them necessary. He soon found, however, that the latter undertaking would be a very unpleasant one, as he must have pointed out at the bottom of many of the pages, the defects and mistakes in the text; whilst numerous modes of illustration, or forms of expression, which his experience as a teacher, had convinced him would not be clear to the learner, must, of necessity, have remained unaltered. He therefore determined to revise the whole work, and with the most perfect freedom, to make such alterations in the body of it, as should, in his opinion, best adapt it to the purpose for which it was designed. Were the book, as it now stands, carefully compared with the original, it would be found, that, in conformity with this determination, scarcely a page of the latter, remains unchanged. Verbal alterations have been made, errors, in points of fact, have been corrected; and new modes of illustration have been introduced, whenever it was thought that those already employed, could be improved; or when it was known, that, from local causes, they are not familiar, in this country.

[Pg iv]

The editor feels assured, that, in performing this task, he has rendered the book more valuable to the teacher, and more useful to the pupil; and he doubts not that the intelligent author of it, would prefer the mode which has been adopted, to that which was at first proposed.

The judicious teacher will, of course, vary the questions according to circumstances; and those who may not employ them at all, as questions, will still find them useful, in directing the pupil to the most important points, in every page.

CONTENTS.

[Pg vi]

CONVERSATION I.

ON GENERAL PROPERTIES OF BODIES. 9
INTRODUCTION. General Properties of Bodies. Impenetrability. Extension. Figure. Divisibility. Inertia. Attraction. Attraction of Cohesion. Density. Rarity. Heat. Attraction of Gravitation.

CONVERSATION II.

ON THE ATTRACTION OF GRAVITY. 22
Attraction of Gravitation, continued. Of Weight. Of the Fall of Bodies. Of the Resistance of the Air. Of the Ascent of Light Bodies.

CONVERSATION III.

ON THE LAWS OF MOTION. 32
Of Motion. Of the Inertia of Bodies. Of Force to produce Motion. Direction of Motion. Velocity, absolute and relative. Uniform Motion. Retarded Motion. Accelerated Motion. Velocity of Falling Bodies. Momentum. Action and Reaction equal. Elasticity of Bodies. Porosity of Bodies. Reflected Motion. Angles of Incidence and Reflection.

CONVERSATION IV.

ON COMPOUND MOTION. 46
Compound Motion, the result of two opposite forces. Of Curvilinear Motion, the result of two forces. Centre of Motion, the point at rest, while the other parts of the body move round it. Centre of Magnitude, the middle of a body. Centripetal Force, that which impels a body towards a fixed central point. Centrifugal Force, that which impels a body to fly from the centre. Fall of Bodies in a Parabola. Centre of Gravity, the point about which the parts balance each other.

CONVERSATION V.

ON THE MECHANICAL POWERS. 54
Of the Power of Machines. Of the Lever in general. Of the Lever of the first kind, having the Fulcrum between the power and the weight. Of the Lever of the second kind, having the Weight between the power and the fulcrum. Of the Lever of the third kind, having the Power between the fulcrum and the weight. Of the Pulley. Of the Wheel and Axle. Of the Inclined Plane. Of the Wedge. Of the Screw.

[Pg vi]

CONVERSATION VI.

ASTRONOMY. 70
CAUSES OF THE MOTION OF THE HEAVENLY BODIES.
Of the Earth's annual motion. Of the Planets, and their motion. Of the Diurnal motion of the Earth and Planets.

CONVERSATION VII.

ON THE PLANETS. 80
Of the Satellites and Moons. Gravity diminishes as the Square of the Distance. Of the Solar System. Of Comets. Constellations, signs of the Zodiac. Of Copernicus, Newton, &c.

CONVERSATION VIII.

ON THE EARTH. 91
Of the Terrestrial Globe. Of the Figure of the Earth. Of the Pendulum. Of the Variation of the Seasons, and of the Length of Days and Nights. Of the Causes of the Heat of Summer. Of Solar, Siderial, and Equal or Mean Time.

CONVERSATION IX.

ON THE MOON. 108
Of the Moon's Motion. Phases of the Moon. Eclipses of the Moon. Eclipses of Jupiter's Moons. Of Latitude and Longitude. Of the Transits of the inferior Planets. Of the Tides.

CONVERSATION X.

HYDROSTATICS. 118
ON THE MECHANICAL PROPERTIES OF FLUIDS.
Definition of a Fluid. Distinction between Fluids and Liquids. Of Non-Elastic Fluids, scarcely susceptible of Compression. Of the Cohesion of Fluids. Of their Gravitation. Of their Equilibrium. Of their Pressure. Of Specific Gravity. Of the Specific Gravity of Bodies heavier than Water. Of those of the same weight as Water. Of those lighter than Water. Of the Specific Gravity of Fluids.

[Pg vii]

CONVERSATION XI.

OF SPRINGS, FOUNTAINS, &c. 128
Of the Ascent of Vapour and the Formation of Clouds. Of the Formation and Fall of Rain, &c. Of the Formation of Springs. Of Rivers and Lakes. Of Fountains.

CONVERSATION XII.	
PNEUMATICS.	
ON THE MECHANICAL PROPERTIES OF AIR.	136
Of the Spring or Elasticity of the Air. Of the Weight of the Air. Experiments with the Air Pump. Of the Barometer. Mode of Weighing Air. Specific Gravity of Air. Of Pumps. Description of the Sucking Pump. Description of the Forcing Pump.	
CONVERSATION XIII.	
ON WIND AND SOUND.	146
Of Wind in General. Of the Trade Wind. Of the Periodical Trade Winds. Of the Aerial Tides. Of Sound in General. Of Sonorous Bodies. Of Musical Sounds. Of Concord or Harmony, and Melody.	
CONVERSATION XIV.	
ON OPTICS.	157
Of Luminous, Transparent, and Opaque Bodies. Of the Radiation of Light. Of Shadows. Of the Reflection of Light. Opaque Bodies seen only by Reflected Light. Vision Explained. Camera Obscura. Image of Objects on the Retina.	
CONVERSATION XV.	
OPTICS— <i>continued.</i>	
OF THE ANGLE OF VISION, AND REFLECTION OF MIRRORS.	168
Angle of Vision. Reflection of Plain Mirrors. Reflection of Convex Mirrors. Reflection of Concave Mirrors.	
CONVERSATION XVI.	
ON REFRACTION AND COLOURS.	179
Transmission of Light by Transparent Bodies. Refraction. Refraction by the Atmosphere. Refraction by a Lens. Refraction by the Prism. Of Colour from the Rays of Light. Of the Colours of Bodies.	
CONVERSATION XVII.	
ON THE STRUCTURE OF THE EYE, AND OPTICAL INSTRUMENTS.	195
Description of the Eye. Of the Image on the Retina. Refraction by the Humours of the Eye. Of the use of Spectacles. Of the Single Microscope. Of the Double Microscope. Of the Solar Microscope. Magic Lantern. Refracting Telescope. Reflecting Telescope.	
Glossary,	205

[Pg viii]

CONVERSATION I. ON GENERAL PROPERTIES OF BODIES.

[Pg 9]

INTRODUCTION. GENERAL PROPERTIES OF BODIES. IMPENETRABILITY. EXTENSION. FIGURE. DIVISIBILITY. INERTIA. ATTRACTION. ATTRACTION OF COHESION. DENSITY. RARITY. HEAT. ATTRACTION OF GRAVITATION.

EMILY.

I must request your assistance, my Dear Mrs. B., in a charge which I have lately undertaken: it is that of instructing my youngest sister, a task, which I find proves more difficult than I had at first imagined. I can teach her the common routine of children's lessons tolerably well; but she is such an inquisitive little creature, that she is not satisfied without an explanation of every difficulty that occurs to her, and frequently asks me questions which I am at a loss to answer. This morning, for instance, when I had explained to her that the world was round like a ball, instead of being flat as she had supposed, and that it was surrounded by the air, she asked me what supported it. I told her that it required no support; she then inquired why it did not fall as every thing else did? This I confess perplexed me; for I had myself been satisfied with learning that the world floated in the air, without considering how unnatural it was that so heavy a body, bearing the weight of all other things, should be able to support itself.

Mrs. B. I make no doubt, my dear, but that I shall be able to explain this difficulty to you; but I believe that it would be almost impossible to render it intelligible to the comprehension of so young a child as your sister Sophia. You, who are now in your thirteenth year, may, I think, with great propriety, learn not only the cause of this particular fact, but acquire a general knowledge of the laws by which the natural world is governed.

Emily. Of all things, it is what I should most like to learn; but I was afraid it was too difficult a study even at my age.

Mrs. B. Not when familiarly explained: if you have patience to attend, I will most willingly give you all the information in my power. You may perhaps find the subject rather dry at first; but if I succeed in explaining the laws of nature, so as to make you understand them, I am sure that you

[Pg 10]

will derive not only instruction, but great amusement from that study.

Emily. I make no doubt of it, Mrs. B.; and pray begin by explaining why the earth requires no support; for that is the point which just now most strongly excites my curiosity.

Mrs. B. My dear Emily, if I am to attempt to give you a general idea of the laws of nature, which is no less than to introduce you to a knowledge of the science of natural philosophy, it will be necessary for us to proceed with some degree of regularity. I do not wish to confine you to the systematic order of a scientific treatise, but if we were merely to examine every vague question that may chance to occur, our progress would be but very slow. Let us, therefore, begin by taking a short survey of the general properties of bodies, some of which must necessarily be explained before I can attempt to make you understand why the earth requires no support.

When I speak of *bodies*, I mean substances, of whatever nature, whether solid or fluid; and *matter* is the general term used to denote the substance, whatever its nature be, of which the different bodies are composed. Thus, the wood of which this table is made, the water with which this glass is filled, and the air which we continually breathe, are each of them *matter*.

Emily. I am very glad you have explained the meaning of the word matter, as it has corrected an erroneous conception I had formed of it: I thought that it was applicable to solid bodies only.

Mrs. B. There are certain properties which appear to be common to all bodies, and are hence called the *essential or inherent properties* of bodies; these are *Impenetrability, Extension, Figure, Divisibility, Inertia* and *Attraction*. These are also called the general properties of bodies, as we do not suppose any body to exist without them.

By *impenetrability* is meant the property which bodies have of occupying a certain space, so that where one body is, another can not be, without displacing the former; for two bodies can not exist in the same place at the same time. A liquid may be more easily removed than a solid body; yet it is not the less substantial, since it is as impossible for a liquid and a solid to occupy the same space at the same time, as for two solid bodies to do so. For instance, if you put a spoon into a glass full of water, the water will flow over to make room for the spoon.

Emily. I understand this perfectly. Liquids are in reality as substantial or as impenetrable as solid bodies, and they appear less so, only because they are more easily displaced.

[Pg 11]

Mrs. B. The air is a fluid differing in its nature from liquids, but no less impenetrable. If I endeavour to fill this phial by plunging it into this bason of water, the air, you see, rushes out of the phial in bubbles, in order to make way for the water, for the air and the water can not exist together in the same space, any more than two hard bodies; and if I reverse this goblet, and plunge it perpendicularly into the water, so that the air will not be able to escape, the water will no longer be able to fill the goblet.

Emily. But it rises some way into the glass.

Mrs. B. Because the water compresses or squeezes the air into a smaller space in the upper part of the glass; but, as long as it remains there, no other body can occupy the same place.

Emily. A difficulty has just occurred to me, with regard to the impenetrability of solid bodies; if a nail is driven into a piece of wood, it penetrates it, and both the wood and the nail occupy the same space that the wood alone did before?

Mrs. B. The nail penetrates between the particles of the wood, by forcing them to make way for it; for you know that not a single atom of wood can remain in the space which the nail occupies; and if the wood is not increased in size by the addition of the nail, it is because wood is a porous substance, like sponge, the particles of which may be compressed or squeezed closer together; and it is thus that they make way for the nail.

We may now proceed to the next general property of bodies, *extension*. A body which occupies a certain space must necessarily have extension; that is to say, *length, breadth* and *depth* or thickness; these are called the dimensions of extension: can you form an idea of any body without them?

Emily. No; certainly I can not; though these dimensions must, of course vary extremely in different bodies. The length, breadth and depth of a box, or of a thimble, are very different from those of a walking stick, or of a hair.

But is not height also a dimension of extension?

Mrs. B. Height and depth are the same dimension, considered in different points of view; if you measure a body, or a space, from the top to the bottom, you call it depth; if from the bottom upwards, you call it height; thus the depth and height of a box are, in fact, the same thing.

[Pg 12]

Emily. Very true; a moment's consideration would have enabled me to discover that; and breadth and width are also the same dimension.

Mrs. B. Yes; the limits of extension constitute *figure* or shape. You conceive that a body having length, breadth and depth, can not be without form, either symmetrical or irregular?

Emily. Undoubtedly; and this property admits of almost an infinite variety.

Mrs. B. Nature has assigned regular forms to many of her productions. The natural form of

various mineral substances is that of crystals, of which there is a great variety. Many of them are very beautiful, and no less remarkable by their transparency or colour, than by the perfect regularity of their forms, as may be seen in the various museums and collections of natural history. The vegetable and animal creation appears less symmetrical, but is still more diversified in figure than the mineral kingdom. Manufactured substances assume the various arbitrary forms which the art of man designs for them; and an infinite number of irregular forms are produced by fractures and by the dismemberment of the parts of bodies.

Emily. Such as a piece of broken china, or glass?

Mrs. B. Or the masses and fragments of stone, and other mineral substances, which are dug out of the earth, or found upon its surface; many of which, although composed of minute crystals, are in the lump of an irregular form.

We may now proceed to *divisibility*; that is to say, a susceptibility of being divided into an indefinite number of parts. Take any small quantity of matter, a grain of sand for instance, and cut it into two parts; these two parts might be again divided, had we instruments sufficiently fine for the purpose; and if by means of pounding, grinding, and other similar methods, we carry this division to the greatest possible extent, and reduce the body to its finest imaginable particles, yet not one of the particles will be destroyed, but will each contain as many halves and quarters, as did the whole grain.

The dissolving of a solid body in a liquid, affords a very striking example of the extreme divisibility of matter; when you sweeten a cup of tea, for instance, with what minuteness the sugar must be divided to be diffused throughout the whole of the liquid.

Emily. And if you pour a few drops of red wine into a glass of water, they immediately tinge the whole of the water, and must therefore be diffused throughout it. [Pg 13]

Mrs. B. Exactly so; and the perfume of this lavender water will be almost as instantaneously diffused throughout the room, if I take out the stopper.

Emily. But in this case it is only the perfume of the lavender, and not the water itself that is diffused in the room.

Mrs. B. The odour or smell of a body is part of the body itself, and is produced by very minute particles or exhalations which escape from the odoriferous bodies. It would be impossible that you should smell the lavender water, if particles of it did not come in actual contact with your nose.

Emily. But when I smell a flower, I see no vapour rise from it; and yet I perceive the smell at a considerable distance.

Mrs. B. You could, I assure you, no more smell a flower, the odoriferous particles of which did not touch your nose, than you could taste a fruit, the flavoured particles of which did not come in contact with your tongue.

Emily. That is wonderful indeed; the particles then, which exhale from the flower and from the lavender water, are, I suppose, too small to be visible?

Mrs. B. Certainly: you may form some idea of their extreme minuteness, from the immense number which must have escaped in order to perfume the whole room; and yet there is no sensible diminution of the liquid in the phial.

Emily. But the quantity must really be diminished?

Mrs. B. Undoubtedly; and were you to leave the bottle open a sufficient length of time, the whole of the water would evaporate and disappear. But though so minutely subdivided as to be imperceptible to any of our senses, each particle would continue to exist; for it is not within the power of man to destroy a single particle of matter: nor is there any reason to suppose that in nature an atom is ever annihilated.

Emily. Yet, when a body is burnt to ashes, part of it, at least, appears to be effectually destroyed: look how small is the residue of ashes in the fire place, from all the fuel which has been consumed within it.

Mrs. B. That part of the fuel, which you suppose to be destroyed, evaporates in the form of smoke, and vapour, and air, whilst the remainder is reduced to ashes. A body, in burning, undergoes no doubt very remarkable changes; it is generally subdivided; its form and colour altered; its extension increased: but the various parts, into which it has been separated by combustion, continue in existence, and retain all the essential properties of bodies. [Pg 14]

Emily. But that part of a burnt body which evaporates in smoke has no figure; smoke, it is true, ascends in columns into the air, but it is soon so much diffused as to lose all form; it becomes indeed invisible.

Mrs. B. Invisible, I allow; but we must not imagine that what we no longer see no longer exists. Were every particle of matter that becomes invisible annihilated, the world itself would in the course of time be destroyed. The particles of smoke, when diffused in the air, continue still to be particles of matter as well as when more closely united in the form of coals: they are really as substantial in the one state as in the other, and equally so when by their extreme subdivision they

become invisible. No particle of matter is ever destroyed: this is a principle you must constantly remember. Every thing in nature decays and corrupts in the lapse of time. We die, and our bodies moulder to dust; but not a single atom of them is lost; they serve to nourish the earth, whence, while living, they drew their support.

The next essential property of matter is called *inertia* or inactivity; this word expresses the resistance which matter makes to a change from a state of rest, to that of motion, or from a state of motion to that of rest. Bodies are equally incapable of changing their actual state, whether it be of motion or of rest. You know that it requires force to put a body which is at rest in motion; an exertion of strength is also requisite to stop a body which is already in motion. The resistance of the body to a change of state, in either case, arises from its *inertia*.

Emily. In playing at base-ball I am obliged to use all my strength to give a rapid motion to the ball; and when I have to catch it, I am sure I feel the resistance it makes to being stopped. But if I did not catch it, it would soon fall to the ground and stop of itself.

Mrs. B. Matter being inert it is as incapable of stopping of itself as it is of putting itself into motion: when the ball ceases to move, therefore, it must be stopped by some other cause or power; but as it is one with which you are yet unacquainted, we can not at present investigate its effects.

The last property which appears to be common to all bodies is *attraction*. All bodies consist of infinitely small particles of matter, each of which possesses the power of attracting or drawing towards it, and uniting with any other particle sufficiently near to be within the influence of its attraction; but in minute particles this power extends to so very small a distance around them, that its effect is not sensible, unless they are (or at least appear to be) in contact; it then makes them stick or adhere together, and is hence called the *attraction of cohesion*. Without this power, solid bodies would fall in pieces, or rather crumble to atoms.

[Pg 15]

Emily. I am so much accustomed to see bodies firm and solid, that it never occurred to me that any power was requisite to unite the particles of which they are composed. But the attraction of cohesion does not, I suppose, exist in liquids; for the particles of liquids do not remain together so as to form a body, unless confined in a vessel?

Mrs. B. I beg your pardon; it is the attraction of cohesion which holds this drop of water suspended at the end of my finger, and keeps the minute watery particles of which it is composed united. But as this power is stronger in proportion as the particles of bodies are more closely united, the cohesive attraction of solid bodies is much greater than that of fluids.

The thinner and lighter a fluid is, the less is the cohesive attraction of its particles, because they are further apart; and in elastic fluids, such as air, there is no cohesive attraction among the particles.

Emily. That is very fortunate; for it would be impossible to breathe the air in a solid mass; or even in a liquid state.

But is the air a body of the same nature as other bodies?

Mrs. B. Undoubtedly, in all essential properties.

Emily. Yet you say that it does not possess one of the general properties of bodies—attraction.

Mrs. B. The particles of air are not destitute of the power of attraction, but they are too far distant from each other to be influenced by it so as to produce cohesion: and the utmost efforts of human art have proved ineffectual in the attempt to compress them, so as to bring them within the sphere of each other's attraction, and make them cohere.

Emily. If so, how is it possible to prove that they are endowed with this power?

Mrs. B. The air is formed of particles precisely of the same nature as those which enter into the composition of liquid and solid bodies, in each of which we have a proof of their attraction.

Emily. It is then, I suppose, owing to the different degrees of cohesive attraction in different substances, that they are hard or soft, and that liquids are thick or thin.

Mrs. B. Yes; but you would express your meaning better by the term *density*, which denotes the degree of closeness and compactness of the particles of a body. In philosophical language, density is said to be that property of bodies by which they contain a certain quantity of matter, under a certain bulk or magnitude. *Rarity* is the contrary of density; it denotes the thinness and subtilty of bodies: thus you would say that mercury or quicksilver was a very dense fluid; ether, a very rare one. Those bodies which are the most dense, do not always cohere the most strongly; lead is more dense than iron, yet its particles are more easily separated.

[Pg 16]

Caroline. But how are we to judge of the quantity of matter contained in a certain bulk?

Mrs. B. By the weight: under the same bulk bodies are said to be dense in proportion as they are heavy.

Emily. Then we may say that metals are dense bodies, wood comparatively a rare one, &c. But, Mrs. B., when the particles of a body are so near as to attract each other, the effect of this power must increase as they are brought by it closer together; so that one would suppose that the body would gradually augment in density, till it was impossible for its particles to be more closely

united. Now, we know that this is not the case; for soft bodies, such as cork, sponge, or butter, never become, in consequence of the increasing attraction of their particles, as hard as iron?

Mrs. B. In such bodies as cork and sponge, the particles which come in contact are so few as to produce but a slight degree of cohesion: they are porous bodies, which, owing to the peculiar arrangement of their particles, abound with interstices, or pores, which separate the particles. But there is also a fluid much more subtle than air, which pervades all bodies, this is *heat*. Heat insinuates itself more or less between the particles of all bodies, and forces them asunder; you may therefore consider heat, and the attraction of cohesion, as constantly acting in opposition to each other.

Emily. The one endeavouring to rend a body to pieces, the other to keep its parts firmly united.

Mrs. B. And it is this struggle between the contending forces of heat and attraction, which prevents the extreme degree of density which would result from the sole influence of the attraction of cohesion.

Emily. The more a body is heated then, the more its particles will be separated.

Mrs. B. Certainly: we find that bodies not only swell or dilate, but lose their cohesion, by heat: this effect is very sensible in butter, for instance, which expands by the application of heat, till at length the attraction of cohesion is so far diminished that the particles separate, and the butter becomes liquid. A similar effect is produced by heat on metals, and all bodies susceptible of being melted. Liquids, you know, are made to boil by the application of heat; the attraction of cohesion then yields entirely to the repulsive power; the particles are totally separated and converted into steam or vapour. But the agency of heat is in no body more sensible than in air, which dilates and contracts by its increase or diminution in a very remarkable degree.

[Pg 17]

Emily. The effects of heat appear to be one of the most interesting parts of natural philosophy.

Mrs. B. That is true; but heat is so intimately connected with chemistry, that you must allow me to defer the investigation of its properties till you become acquainted with that science.

To return to its antagonist, the attraction of cohesion; it is this power which restores to vapour its liquid form, which unites it into drops when it falls to earth in a shower of rain, which gathers the dew into brilliant gems on the blades of grass.

Emily. And I have often observed that after a shower, the water collects into large drops on the leaves of plants; but I cannot say that I perfectly understand how the attraction of cohesion produces this effect.

Mrs. B. Rain, when it first leaves the clouds, is not in the form of drops, but in that of mist or vapour, which is composed of very small watery particles; these in their descent mutually attract each other, and those that are sufficiently near in consequence unite and form a drop, and thus the mist is transformed into a shower. The dew also was originally in a state of vapour, but is, by the mutual attraction of the particles, formed into small globules on the blades of grass: in a similar manner the rain upon the leaf collects into large drops, which when they become too heavy for the leaf to support, fall to the ground.

Emily. All this is wonderfully curious! I am almost bewildered with surprise and admiration at the number of new ideas I have already acquired.

Mrs. B. Every step that you advance in the pursuit of natural science, will fill your mind with admiration and gratitude towards its Divine Author. In the study of natural philosophy, we must consider ourselves as reading the book of nature, in which the bountiful goodness and wisdom of God are revealed to all mankind; no study can tend more to purify the heart, and raise it to a religious contemplation of the Divine perfections.

[Pg 18]

There is another curious effect of the attraction of cohesion which I must point out to you; this is called capillary attraction. It enables liquids to rise above their ordinary level in capillary tubes: these are tubes, the bores of which are so extremely small that liquids ascend within them, from the cohesive attraction between the particles of the liquid and the interior surface of the tube. Do you perceive the water rising in this small glass tube, above its level in the goblet of water, into which I have put one end of it?

Emily. Oh yes; I see it slowly creeping up the tube, but now it is stationary: will it rise no higher?

Mrs. B. No; because the cohesive attraction between the water and the internal surface of the tube is now balanced by the weight of the water within it; if the bore of the tube were narrower the water would rise higher; and if you immerse several tubes of bores of different sizes, you will see it rise to different heights in each of them. In making this experiment, you should colour the water with a little red wine, in order to render the effect more obvious.

All porous substances, such as sponge, bread, linen, &c. may be considered as collections of capillary tubes: if you dip one end of a lump of sugar into water, the fluid will rise in it, and wet it considerably above the surface of the water into which you dip it.

Emily. In making tea I have often observed that effect, without being able to account for it.

Mrs. B. Now that you are acquainted with the attraction of cohesion, I must endeavour to explain to you that of *Gravitation*, which is probably a modification of the same power; the first is

perceptible only in very minute particles, and at very small distances; the other acts on the largest bodies, and extends to immense distances.

Emily. You astonish me: surely you do not mean to say that large bodies attract each other?

Mrs. B. Indeed I do: let us take, for example, one of the largest bodies in nature, and observe whether it does not attract other bodies. What is it that occasions the fall of this book, when I no longer support it?

Emily. Can it be the attraction of the earth? I thought that all bodies had a natural tendency to fall. [Pg 19]

Mrs. B. They have a natural tendency to fall, it is true; but that tendency is produced entirely by the attraction of the earth: the earth being so much larger than any body on its surface, forces every body, which is not supported, to fall upon it.

Emily. If the tendency which bodies have to fall results from the earth's attractive power, the earth itself can have no such tendency, since it cannot attract itself, and therefore it requires no support to prevent it from falling. Yet the idea that bodies do not fall of their own accord, but that they are drawn towards the earth by its attraction, is so new and strange to me, that I know not how to reconcile myself to it.

Mrs. B. When you are accustomed to consider the fall of bodies as depending on this cause, it will appear to you as natural, and surely much more satisfactory, than if the cause of their tendency to fall were totally unknown. Thus you understand that all matter is attractive, from the smallest particle to the largest mass; and that bodies attract each other with a force proportional to the quantity of matter they contain.

Emily. I do not perceive any difference between the attraction of cohesion and that of gravitation; is it not because every particle of matter is endowed with an attractive power, that large bodies consisting of a great number of particles, are so strongly attractive?

Mrs. B. True. There is, however, this difference between the attraction of particles and that of masses, that the former takes place only when the particles are contiguous, whilst the latter is exerted when the masses are far from each other. The attraction of particles frequently counteracts the attraction of gravitation. Of this you have an instance in the attraction of capillary tubes, in which liquids ascend by the attraction of cohesion, in opposition to that of gravity. It is on this account that it is necessary that the bore of the tube should be extremely small; for if the column of water within the tube is not very minute, the attraction of cohesion would not be able either to raise or support it in opposition to its gravity; because the increase of weight, in a column of water of a given height, is much greater than the increase in the attracting surface of the tube, when its size is increased.

You may observe also, that all solid bodies are enabled by the force of the cohesive attraction of their particles to resist that of gravity, which would otherwise disunite them, and bring them to a level with the ground, as it does in the case of a liquid, the cohesive attraction of which is not sufficient to enable it to resist the power of gravity. [Pg 20]

Emily. And some solid bodies appear to be of this nature, as sand, and powder for instance: there is no attraction of cohesion between their particles?

Mrs. B. Every grain of powder, or sand, is composed of a great number of other more minute particles, firmly united by the attraction of cohesion; but amongst the separate grains there is no sensible attraction, because they are not in sufficiently close contact.

Emily. Yet they actually touch each other?

Mrs. B. The surface of bodies is in general so rough and uneven, that when in apparent contact, they touch each other only by a few points. Thus, when I lay this book upon the table, the binding of which appears perfectly smooth, so few of the particles of its under surface come in contact with the table, that no sensible degree of cohesive attraction takes place; for you see that it does not stick or cohere to the table, and I find no difficulty in lifting it off.

It is only when surfaces, perfectly flat and well polished, are placed in contact, that the particles approach in sufficient number, and closely enough, to produce a sensible degree of cohesive attraction. Here are two plates of polished metal, I press their flat surfaces together, having previously interposed a few drops of oil, to fill up every little porous vacancy. Now try to separate them.

Emily. It requires an effort beyond my strength, though there are handles for the purpose of pulling them asunder. Is the firm adhesion of the two plates merely owing to the attraction of cohesion?

Mrs. B. There is no force more powerful, since it is by this that the particles of the hardest bodies are held together. It would require a weight of several pounds to separate these plates. In the present example, however, much of the cohesive force is due to the attraction subsisting between the metal and the oil which is interposed; as without this, or some other fluid, the points of contact would still be comparatively few, although we may have employed our utmost art, in giving flat surfaces to the plates.

Emily. In making a kaleidoscope, I recollect that the two plates of glass, which were to serve as

mirrors, stuck so fast together, that I imagined some of the gum I had been using had by chance been interposed between them; but I am now convinced that it was their own natural cohesive attraction which produced this effect.

Mrs. B. Very probably it was so; for plate-glass has an extremely smooth, flat surface, admitting of the contact of a great number of particles, when two plates are laid upon each other.

Emily. But, Mrs. B., the cohesive attraction of some substances is much greater than that of others; thus glue, gum and paste, cohere with singular tenacity.

Mrs. B. Bodies which differ in their natures in other respects, differ also in their cohesive attraction; it is probable that there are no two bodies, the particles of which attract each other with precisely the same force.

There are some other modifications of attraction peculiar to certain bodies; namely, that of magnetism, of electricity, and of affinity, or chemical attraction; but we shall confine our attention merely to the attraction of cohesion and of gravity; the examination of the latter we shall resume at our next meeting.

Questions

1. (Pg. 10) What is intended by the term *bodies*?
2. (Pg. 10) Is the term *matter*, restricted to substances of a particular kind?
3. (Pg. 10) Name those properties of bodies, which are called inherent.
4. (Pg. 10) What is meant by impenetrability?
5. (Pg. 10) Can a liquid be said to be impenetrable?
6. (Pg. 11) How can you prove that air is impenetrable?
7. (Pg. 11) If air is impenetrable, what causes the water to rise some way into a goblet, if I plunge it into water with its mouth downward?
8. (Pg. 11) When I drive a nail into wood, do not both the iron and the wood occupy the same space?
9. (Pg. 11) In how many directions, is a body said to have extension?
10. (Pg. 11) How do we distinguish the terms height and depth?
11. (Pg. 12) What constitutes the *figure*, or *form* of a body?
12. (Pg. 12) What is said respecting the form of minerals?
13. (Pg. 12) What of the vegetable and animal creation?
14. (Pg. 12) What of artificial, and accidental forms?
15. (Pg. 12) What is meant by divisibility?
16. (Pg. 12) What examples can you give, to prove that the particles of a body are minute in the extreme?
17. (Pg. 13) What produces the odour of bodies?
18. (Pg. 13) How do odours exemplify the minuteness of the particles of matter?
19. (Pg. 13) Can matter be in any way annihilated?
20. (Pg. 13) What becomes of the fuel, which disappears in our fires?
21. (Pg. 14) How can that part which evaporates, be still said to possess a substantial form?
22. (Pg. 14) What do we mean by *inertia*?
23. (Pg. 14) Give an example to prove that force is necessary, either to give or to stop motion.
24. (Pg. 14) What general power do the particles of matter exert upon other particles?
25. (Pg. 15) What is that species of attraction called, which keeps bodies in a solid state?
26. (Pg. 15) Does the attraction of cohesion exist in liquids, and how is its existence proved?
27. (Pg. 15) If the particles of air attract each other, why do they not cohere?
28. (Pg. 15) From what then do you infer that they possess attraction?
29. (Pg. 15) How do you account for some bodies being hard and others soft?
30. (Pg. 16) What is meant by the term *density*?
31. (Pg. 16) Do the most dense bodies always cohere the most strongly?
32. (Pg. 16) How do we know that one body is more dense than another?
33. (Pg. 16) What is there which acts in opposition to cohesive attraction, tending to separate the particles of bodies?
34. (Pg. 17) What would be the consequence if the repulsive power of heat were not exerted?
35. (Pg. 17) If we continue to increase the heat, what effects will it produce on bodies?
36. (Pg. 17) What body has its dimensions most sensibly affected by change of temperature?
37. (Pg. 17) What power restores vapours to the liquid form?
38. (Pg. 17) What examples can you give?
39. (Pg. 17) How are drops of rain and of dew said to be formed?
40. (Pg. 18) What is meant by a capillary tube?
41. (Pg. 18) What effect does attraction produce when these are immersed in water?
42. (Pg. 18) What is the reason that the water rises to a certain height only?
43. (Pg. 18) Give some familiar examples of capillary attraction.
44. (Pg. 18) In what does *gravitation* differ from cohesive attraction?
45. (Pg. 18) What causes bodies near the earth's surface, to have a tendency to fall towards it?
46. (Pg. 19) What remarkable difference is there between the attraction of gravitation, and that of cohesion?
47. (Pg. 19) In what instances does the power of cohesion counteract that of gravitation?
48. (Pg. 19) Why will water rise to a less height, if the size of the tube is increased?
49. (Pg. 20) Why do not two bodies cohere, when laid upon each other?
50. (Pg. 20) Can two bodies be made sufficiently flat to cohere with considerable force?
51. (Pg. 20) What is the reason that the adhesion is greater when oil is interposed?
52. (Pg. 21) What other modifications of attraction are there, besides those of cohesion and of gravitation?

CONVERSATION II. ON THE ATTRACTION OF GRAVITY.

ATTRACTION OF GRAVITATION, CONTINUED. OF WEIGHT. OF THE FALL OF BODIES. OF THE RESISTANCE OF THE AIR. OF THE ASCENT OF LIGHT BODIES.

EMILY.

I have related to my sister Caroline all that you have taught me of natural philosophy, and she has been so much delighted by it, that she hopes you will have the goodness to admit her to your lessons.

Mrs. B. Very willingly; but I did not think you had any taste for studies of this nature, Caroline.

Caroline. I confess, Mrs. B., that hitherto I had formed no very agreeable idea either of philosophy, or philosophers; but what Emily has told me has excited my curiosity so much, that I shall be highly pleased if you will allow me to become one of your pupils.

Mrs. B. I fear that I shall not find you so tractable a scholar as Emily; I know that you are much biased in favour of your own opinions.

Caroline. Then you will have the greater merit in reforming them, Mrs. B.; and after all the wonders that Emily has related to me, I think I stand but little chance against you and your attractions.

Mrs. B. You will, I doubt not, advance a number of objections; but these I shall willingly admit, as they will afford an opportunity of elucidating the subject. Emily, do you recollect the names of the general properties of bodies?

Emily. Impenetrability, extension, figure, divisibility, inertia and attraction.

Mrs. B. Very well. You must remember that these are properties common to all bodies, and of which they cannot be deprived; all other properties of bodies are called accidental, because they depend on the relation or connexion of one body to another.

Caroline. Yet surely, Mrs. B., there are other properties which are essential to bodies, besides those you have enumerated. Colour and weight, for instance, are common to all bodies, and do not arise from their connexion with each other, but exist in the bodies themselves; these, therefore, cannot be accidental qualities? [Pg 23]

Mrs. B. I beg your pardon; these properties do not exist in bodies independently of their connexion with other bodies.

Caroline. What! have bodies no weight? Does not this table weigh heavier than this book; and, if one thing weighs heavier than another, must there not be such a thing as weight?

Mrs. B. No doubt: but this property does not appear to be essential to bodies; it depends upon their connexion with each other. Weight is an effect of the power of attraction, without which the table and the book would have no weight whatever.

Emily. I think I understand you; it is the attraction of gravity which makes bodies heavy.

Mrs. B. You are right. I told you that the attraction of gravity was proportioned to the quantity of matter which bodies contain: now the earth consisting of a much greater quantity of matter than any body upon its surface, the force of its attraction must necessarily be greatest, and must draw every thing so situated towards it; in consequence of which, bodies that are unsupported fall to the ground, whilst those that are supported, press upon the object which prevents their fall, with a weight equal to the force with which they gravitate towards the earth.

Caroline. The same cause then which occasions the fall of bodies, produces their weight also. It was very dull in me not to understand this before, as it is the natural and necessary consequence of attraction; but the idea that bodies were not really heavy of themselves, appeared to me quite incomprehensible. But, Mrs. B., if attraction is a property essential to matter, weight must be so likewise; for how can one exist without the other?

Mrs. B. Suppose there were but one body existing in universal space, what would its weight be?

Caroline. That would depend upon its size; or more accurately speaking, upon the quantity of matter it contained.

Emily. No, no; the body would have no weight, whatever were its size; because nothing would attract it. Am I not right, Mrs. B.?

Mrs. B. You are: you must allow, therefore, that it would be possible for attraction to exist without weight; for each of the particles of which the body was composed, would possess the power of attraction; but they could exert it only amongst themselves; the whole mass having [Pg 24]

nothing to attract, or to be attracted by, would have no weight.

Caroline. I am now well satisfied that weight is not essential to the existence of bodies; but what have you to object to colours, Mrs. B.; you will not, I think, deny that they really exist in the bodies themselves.

Mrs. B. When we come to treat of the subject of colours, I trust that I shall be able to convince you, that colours are likewise accidental qualities, quite distinct from the bodies to which they appear to belong.

Caroline. Oh do pray explain it to us now, I am so very curious to know how that is possible.

Mrs. B. Unless we proceed with some degree of order and method, you will in the end find yourself but little the wiser for all you learn. Let us therefore go on regularly, and make ourselves well acquainted with the general properties of bodies before we proceed further.

Emily. To return, then, to attraction, (which appears to me by far the most interesting of them, since it belongs equally to all kinds of matter,) it must be mutual between two bodies; and if so, when a stone falls to the earth, the earth should rise part of the way to meet the stone?

Mrs. B. Certainly; but you must recollect that the force of attraction is proportioned to the quantity of matter which bodies contain, and if you consider the difference there is in that respect, between a stone and the earth, you will not be surprised that you do not perceive the earth rise to meet the stone; for though it is true that a mutual attraction takes place between the earth and the stone, that of the latter is so very small in comparison to that of the former, as to render its effect insensible.

Emily. But since attraction is proportioned to the quantity of matter which bodies contain, why do not the hills attract the houses and churches towards them?

Caroline. What an idea, Emily! How can the houses and churches be moved, when they are so firmly fixed in the ground!

Mrs. B. Emily's question is not absurd, and your answer, Caroline, is perfectly just; but can you tell us why the houses and churches are so firmly fixed in the ground? [Pg 25]

Caroline. I am afraid I have answered right by mere chance; for I begin to suspect that bricklayers and carpenters could give but little stability to their buildings, without the aid of attraction.

Mrs. B. It is certainly the cohesive attraction between the bricks and the mortar, which enables them to build walls, and these are so strongly attracted by the earth, as to resist every other impulse; otherwise they would necessarily move towards the hills and the mountains; but the lesser force must yield to the greater. There are, however, some circumstances in which the attraction of a large body has sensibly counteracted that of the earth. If whilst standing on the declivity of a mountain, you hold a plumb-line in your hand, the weight will not fall perpendicular to the earth, but incline a little towards the mountain; and this is owing to the lateral, or sideways attraction of the mountain, interfering with the perpendicular attraction of the earth.

Emily. But the size of a mountain is very trifling, compared to the whole earth.

Mrs. B. Attraction, you must recollect, is in proportion to the quantity of matter, and although that of the mountain, is much less than that of the earth, it may yet be sufficient to act sensibly upon the plumb-line which is so near to it.

Caroline. Pray, Mrs. B., do the two scales of a balance hang parallel to each other?

Mrs. B. You mean, I suppose, in other words to inquire whether two lines which are perpendicular to the earth, are parallel to each other? I believe I guess the reason of your question; but I wish you would endeavour to answer it without my assistance.

Caroline. I was thinking that such lines must both tend by gravity to the same point, the centre of the earth; now lines tending to the same point cannot be parallel, as parallel lines are always at an equal distance from each other, and would never meet.

Mrs. B. Very well explained; you see now the use of your knowledge of parallel lines: had you been ignorant of their properties, you could not have drawn such a conclusion. This may enable you to form an idea of the great advantage to be derived even from a slight knowledge of geometry, in the study of natural philosophy; and if after I have made you acquainted with the first elements, you should be tempted to pursue the study, I would advise you to prepare yourselves by acquiring some knowledge of geometry. This science would teach you that lines which fall perpendicular to the surface of a sphere cannot be parallel, because they would all meet, if prolonged to the centre of the sphere; while lines that fall perpendicular to a plane or flat surface, are always parallel, because if prolonged, they would never meet. [Pg 26]

Emily. And yet a pair of scales, hanging perpendicular to the earth, appear parallel?

Mrs. B. Because the sphere is so large, and the scales consequently converge so little, that their inclination is not perceptible to our senses; if we could construct a pair of scales whose beam would extend several degrees, their convergence would be very obvious; but as this cannot be accomplished, let us draw a small figure of the earth, and then we may make a pair of scales of the proportion we please. ([fig. 1. pl. I.](#))

Caroline. This figure renders it very clear: then two bodies cannot fall to the earth in parallel lines?

Mrs. B. Never.

Caroline. The reason that a heavy body falls quicker than a light one, is, I suppose, because the earth attracts it more strongly.

Mrs. B. The earth, it is true, attracts a heavy body more than a light one; but that would not make the one fall quicker than the other.

Caroline. Yet, since it is attraction that occasions the fall of bodies, surely the more a body is attracted, the more rapidly it will fall. Besides, experience proves it to be so. Do we not every day see heavy bodies fall quickly, and light bodies slowly?

Emily. It strikes me, as it does Caroline, that as attraction is proportioned to the quantity of matter, the earth must necessarily attract a body which contains a great quantity more strongly, and therefore bring it to the ground sooner than one consisting of a smaller quantity.

Mrs. B. You must consider, that if heavy bodies are attracted more strongly than light ones, they require more attraction to make them fall. Remember that bodies have no natural tendency to fall, any more than to rise, or to move laterally, and that they will not fall unless impelled by some force; now this force must be proportioned to the quantity of matter it has to move: a body consisting of 1000 particles of matter, for instance, requires ten times as much attraction to bring it to the ground in the same space of time as a body consisting of only 100 particles.

PLATE I.

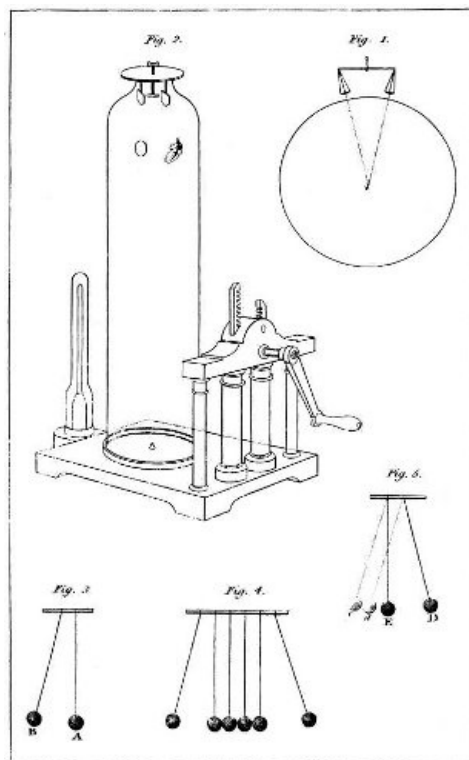

Caroline. I do not understand that; for it seems to me, that the heavier a body is, the more easily and readily it falls. [Pg 27]

Emily. I think I now comprehend it; let me try if I can explain it to Caroline. Suppose that I draw towards me two weighty bodies, the one of 100 lbs. the other of 1000 lbs. must I not exert ten times as much strength to draw the larger one to me, in the same space of time, as is required for the smaller one? And if the earth draws a body of 1000 lbs. weight to it in the same space of time that it draws a body of 100 lbs. does it not follow that it attracts the body of 1000 lbs. weight with ten times the force that it does that of 100 lbs.?

Caroline. I comprehend your reasoning perfectly; but if it were so, the body of 1000 lbs. weight, and that of 100 lbs. would fall with the same rapidity; and the consequence would be, that all bodies, whether light or heavy, being at an equal distance from the ground, would fall to it in the same space of time: now it is very evident that this conclusion is absurd; experience every instant contradicts it; observe how much sooner this book reaches the floor than this sheet of paper, when I let them drop together.

Emily. That is an objection I cannot answer. I must refer it to you, Mrs. B.

Mrs. B. I trust that we shall not find it insurmountable. It is true that, according to the laws of attraction, all bodies at an equal distance from the earth, should fall to it in the same space of time; and this would actually take place if no obstacle intervened to impede their fall. But bodies fall through the air, and it is the resistance of the air which makes bodies of different density fall with different degrees of velocity. They must all force their way through the air, but dense heavy

bodies overcome this obstacle more easily than rarer or lighter ones; because in the same space they contain more gravitating particles.

The resistance which the air opposes to the fall of bodies is proportioned to their surface, not to their weight; the air being inert, cannot exert a greater force to support the weight of a cannon ball, than it does to support the weight of a ball (of the same size) made of leather; but the cannon ball will overcome this resistance more easily, and fall to the ground, consequently, quicker than the leather ball.

Caroline. This is very clear and solves the difficulty perfectly. The air offers the same resistance to a bit of lead and a bit of feather of the same size; yet the one seems to meet with no obstruction in its fall, whilst the other is evidently resisted and supported for some time by the air.

[Pg 28]

Emily. The larger the surface of a body, then, the more air it covers, and the greater is the resistance it meets with from it.

Mrs. B. Certainly: observe the manner in which this sheet of paper falls; it floats awhile in the air, and then gently descends to the ground. I will roll the same piece of paper up into a ball: it offers now but a small surface to the air, and encounters therefore but little resistance: see how much more rapidly it falls.

The heaviest bodies may be made to float awhile in the air, by making the extent of their surface counterbalance their weight. Here is some gold, which is one of the most dense bodies we are acquainted with; but it has been beaten into a very thin leaf, and offers so great an extent of surface in proportion to its weight, that its fall, you see, is still more retarded by the resistance of the air, than that of the sheet of paper.

Caroline. That is very curious: and it is, I suppose, upon the same principle that a thin slate sinks in water more slowly than a round stone.

But, Mrs. B., if the air is a real body, is it not also subjected to the laws of gravity?

Mrs. B. Undoubtedly.

Caroline. Then why does it not, like all other bodies, fall to the ground?

Mrs. B. On account of its spring or elasticity. The air is an *elastic fluid*; and the peculiar property of elastic bodies is to resume, after compression, their original dimensions; and you must consider the air of which the atmosphere is composed as existing in a state of compression, for its particles being drawn towards the earth by gravity, are brought closer together than they would otherwise be, but the spring or elasticity of the air by which it endeavours to resist compression, gives it a constant tendency to expand itself, so as to resume the dimensions it would naturally have, if not under the influence of gravity. The air may therefore be said constantly to struggle with the power of gravity without being able to overcome it. Gravity thus confines the air to the regions of our globe, whilst its elasticity prevents it from falling, like other bodies, to the ground.

Emily. The air then is, I suppose, thicker, or I should rather say more dense, near the surface of the earth, than in the higher regions of the atmosphere; for that part of the air which is nearer the surface of the earth must be most strongly attracted.

[Pg 29]

Mrs. B. The diminution of the force of gravity, at so small a distance as that to which the atmosphere extends (compared with the size of the earth) is so inconsiderable as to be scarcely sensible; but the pressure of the upper parts of the atmosphere on those beneath, renders the air near the surface of the earth much more dense than in the upper regions. The pressure of the atmosphere has been compared to that of a pile of fleeces of wool, in which the lower fleeces are pressed together by the weight of those above; these lie light and loose, in proportion as they approach the uppermost fleece, which receives no external pressure, and is confined merely by the force of its own gravity.

Emily. I do not understand how it is that the air can be springy or elastic, as the particles of which it is composed must, according to the general law, attract each other; yet their elasticity, must arise from a tendency to recede from each other.

Mrs. B. Have you forgotten what I told you respecting the effects of heat, a fluid so subtle that it readily pervades all substances, and even in solid bodies, counteracts the attraction of cohesion? In air the quantity of heat interposed is so great, as to cause its particles actually to repel each other, and it is to this that we must ascribe its elasticity; this, however, does not prevent the earth from exerting its attraction upon the individual particles of which it consists.

Caroline. It has just occurred to me that there are some bodies which do not gravitate towards the earth. Smoke and steam, for instance, rise instead of falling.

Mrs. B. It is still gravity which produces their ascent; at least, were that power destroyed, these bodies would not rise.

Caroline. I shall be out of conceit with gravity, if it is so inconsistent in its operations.

Mrs. B. There is no difficulty in reconciling this apparent inconsistency of effect. The air near the earth is heavier than smoke, steam, or other vapours; it consequently not only supports these

light bodies, but forces them to rise, till they reach a part of the atmosphere, the weight of which is not greater than their own, and then they remain stationary. Look at this bason of water; why does the piece of paper which I throw into it float on the surface?

Emily. Because, being lighter than the water, it is supported by it.

Mrs. B. And now that I pour more water into the bason, why does the paper rise?

[Pg 30]

Emily. The water being heavier than the paper, gets beneath it, and obliges it to rise.

Mrs. B. In a similar manner are smoke and vapour forced upwards by the air; but these bodies do not, like the paper, ascend to the surface of the fluid, because, as we observed before, the air being less dense, and consequently lighter as it is more distant from the earth, vapours rise only till they attain a region of air of their own density. Smoke, indeed ascends but a very little way; it consists of minute particles of fuel, carried up by a current of heated air, from the fire below: heat, you recollect, expands all bodies; it consequently rarefies air, and renders it lighter than the colder air of the atmosphere; the heated air from the fire carries up with it vapour and small particles of the combustible materials which are burning in the fire. When this current of hot air is cooled by mixing with the atmosphere, the minute particles of coal, or other combustible, fall; it is this which produces the small black flakes which render the air, and every thing in contact with it, in London, so dirty.

Caroline. You must, however, allow me to make one more objection to the universal gravity of bodies; which is the ascent of air balloons, the materials of which are undoubtedly heavier than air: how, therefore, can they be supported by it?

Mrs. B. I admit that the materials of which balloons are made are heavier than the air; but the air with which they are filled is an elastic fluid, of a different nature from atmospheric air, and considerably lighter; so that on the whole the balloon is lighter than the air which it displaces, and consequently will rise, on the same principle as smoke and vapour. Now, Emily, let me hear if you can explain how the gravity of bodies is modified by the effect of the air?

Emily. The air forces bodies which are lighter than itself to ascend; those that are of an equal weight will remain stationary in it; and those that are heavier will descend through it: but the air will have some effect on these last; for if they are not much heavier, they will with difficulty overcome the resistance they meet with in passing through it, they will be borne up by it, and their fall will be more or less retarded.

Mrs. B. Very well. Observe how slowly this light feather falls to the ground, while a heavier body, like this marble, overcomes the resistance which the air makes to its descent much more easily, and its fall is proportionally more rapid. I now throw a pebble into this tub of water; it does not reach the bottom near so soon as if there were no water in the tub, because it meets with resistance from the water. Suppose that we could empty the tub, not only of water, but of air also, the pebble would then fall quicker still, as it would in that case meet with no resistance at all to counteract its gravity.

[Pg 31]

Thus you see that it is not the different degrees of gravity, but the resistance of the air, which prevents bodies of different weight from falling with equal velocities; if the air did not bear up the feather, it would reach the ground as soon as the marble.

Caroline. I make no doubt that it is so; and yet I do not feel quite satisfied. I wish there was any place void of air, in which the experiment could be made.

Mrs. B. If that proof will satisfy your doubts, I can give it you. Here is a machine called an *air pump*, ([fig. 2. pl. 1.](#)) by means of which the air may be expelled from any close vessel which is placed over this opening, through which the air is pumped out. Glasses of various shapes, usually called receivers, are employed for this purpose. We shall now exhaust the air from this tall receiver which is placed over the opening, and we shall find that bodies within it, whatever their weight or size, will fall from the top to the bottom in the same space of time.

Caroline. Oh, I shall be delighted with this experiment; what a curious machine! how can you put the two bodies of different weight within the glass, without admitting the air?

Mrs. B. A guinea and a feather are already placed there for the purpose of the experiment: here is, you see, a contrivance to fasten them in the upper part of the glass; as soon as the air is pumped out, I shall turn this little screw, by which means the brass plates which support them will be removed, and the two bodies will fall.—Now I believe I have pretty well exhausted the air.

Caroline. Pray let me turn the screw.—I declare, they both reached the bottom at the same instant! Did you see, Emily, the feather appeared as heavy as the guinea?

Emily. Exactly; and fell just as quickly. How wonderful this is! what a number of entertaining experiments might be made with this machine!

Mrs. B. No doubt there are a great many; but we shall reserve them to elucidate the subjects to which they relate: if I had not explained to you why the guinea, and the feather fell with equal velocity, you would not have been so well pleased with the experiment.

[Pg 32]

Emily. I should have been as much surprised, but not so much interested; besides, experiments help to imprint on the memory the facts they are intended to illustrate; it will be better therefore for us to restrain our curiosity, and wait for other experiments in their proper places.

Caroline. Pray by what means is this receiver exhausted of its air?

Mrs. B. You must learn something of mechanics in order to understand the construction of a pump. At our next meeting, therefore, I shall endeavour to make you acquainted with the laws of motion, as an introduction to that subject.

Questions

1. (Pg. 22) What are those properties of bodies called, which are not common to all?
2. (Pg. 23) Why are they so called?
3. (Pg. 23) What is the cause of weight in bodies?
4. (Pg. 23) What is the reason that all bodies near to the surface of the earth, are drawn towards it?
5. (Pg. 24) If attraction is the cause of weight, could you suppose it possible for a body to possess the former and not the latter property?
6. (Pg. 24) When a stone falls to the ground, in which of the two bodies does the power of attraction exist?
7. (Pg. 24) If the attraction be mutual, why does not the earth approach the stone, as much as the stone approaches the earth?
8. (Pg. 24) If attraction be in proportion to the mass, why does not a hill, draw towards itself, a house placed near it?
9. (Pg. 25) How can the attraction of a mountain be rendered sensible?
10. (Pg. 25) Why cannot two lines which are perpendicular to the surface of the earth be parallel to each other?
11. (Pg. 26) Draw a small figure of the earth to exemplify this, as in [fig. 1. plate 1.](#)
12. (Pg. 27) If bodies were not resisted by the air, those which are light, would fall as quickly as those which are heavy, how can you account for this?
13. (Pg. 27) What then is the reason that a book, and a sheet of paper, let fall from the same height, will not reach the ground in the same time?
14. (Pg. 28) What then will be the effect of increasing the surface of a body?
15. (Pg. 28) What could you do to a sheet of paper, to make it fall quickly, and why?
16. (Pg. 28) Inform me how a very dense body may be made to float in the air?
17. (Pg. 28) The air is a real body, why does it not fall to the ground?
18. (Pg. 29) The air is more dense near the surface of the earth, and decreases in density as you ascend, how is this accounted for, and to what is it compared?
19. (Pg. 29) What is it which causes the particles of air to recede from each other, and seems to destroy their mutual attraction?
20. (Pg. 29) Smoke and vapour ascend in the atmosphere, how can you reconcile this with gravitation?
21. (Pg. 30) How would you illustrate this by the floating of a piece of paper on water?
22. (Pg. 30) Does smoke rise to a great height in the air, and if not, what prevents its so doing?
23. (Pg. 30) What limits the height to which vapours rise?
24. (Pg. 30) Of what does smoke consist?
25. (Pg. 30) Air balloons are formed of heavy materials, how will you account for their rising in the air?
26. (Pg. 30) What influence does the air exert, on bodies less dense than itself, on those of equal, and on those of greater density?
27. (Pg. 31) If the air could be entirely removed, what influence would this have upon the falling of heavy and light bodies?
28. (Pg. 31) How could this be exemplified by means of the air pump?

CONVERSATION III. ON THE LAWS OF MOTION.

OF MOTION. OF THE INERTIA OF BODIES. OF FORCE TO PRODUCE MOTION. DIRECTION OF MOTION. VELOCITY, ABSOLUTE AND RELATIVE. UNIFORM MOTION. RETARDED MOTION. ACCELERATED MOTION. VELOCITY OF FALLING BODIES. MOMENTUM. ACTION AND REACTION EQUAL. ELASTICITY OF BODIES. POROSITY OF BODIES. REFLECTED MOTION. ANGLES OF INCIDENCE AND REFLECTION.

MRS. B.

The science of mechanics is founded on the laws of motion; it will therefore be necessary to make you acquainted with these laws before we examine the mechanical powers. Tell me, *Caroline*, what do you understand by the word motion?

Caroline. I think I understand it perfectly, though I am at a loss to describe it. Motion is the act of moving about, of going from one place to another, it is the contrary of remaining at rest.

Mrs. B. Very well. Motion then consists in a change of place; a body is in motion whenever it is changing its situation with regard to a fixed point.

Now since we have observed that one of the general properties of bodies is inertia, that is, an

entire passiveness, either with regard to motion or rest, it follows that a body cannot move without being put into motion; the power which puts a body into motion is called *force*; thus the stroke of the hammer is the force which drives the nail; the pulling of the horse that which draws the carriage, &c. Force then is the cause which produces motion.

[Pg 33]

Emily. And may we not say that gravity is the force which occasions the fall of bodies?

Mrs. B. Undoubtedly. I have given you the most familiar illustrations in order to render the explanation clear; but since you seek for more scientific examples, you may say that cohesion is the force which binds the particles of bodies together, and heat that which drives them asunder.

The motion of a body acted upon by a single force, is always in a straight line, and in the direction in which it received the impulse.

Caroline. That is very natural; for as the body is inert, and can move only because it is impelled, it will move only in the direction in which it is impelled. The degree of quickness with which it moves, must, I suppose, also depend upon the degree of force with which it is impelled.

Mrs. B. Yes; the rate at which a body moves, or the shortness of the time which it takes to move from one place to another, is called its velocity; and it is one of the laws of motion, that the velocity of the moving body is proportional to the force by which it is put in motion. We must distinguish between absolute and relative velocity.

The velocity of a body is called *absolute*, if we consider the motion of the body in space, without any reference to that of other bodies. When, for instance, a horse goes fifty miles in ten hours, his velocity is five miles an hour.

The velocity of a body is termed *relative*, when compared with that of another body which is itself in motion. For instance, if one man walks at the rate of a mile an hour, and another at the rate of two miles an hour, the relative velocity of the latter is double that of the former; but the absolute velocity of the one is one mile, and that of the other two miles an hour.

Emily. Let me see if I understand it—The relative velocity of a body is the degree of rapidity of its motion compared with that of another body; thus if one ship sail three times as far as another ship in the same space of time, the velocity of the former is equal to three times that of the latter.

Mrs. B. The general rule may be expressed thus: the velocity of a body is measured by the space over which it moves, divided by the time which it employs in that motion: thus if you travel one hundred miles in twenty hours, what is your velocity in each hour?

[Pg 34]

Emily. I must divide the space, which is one hundred miles, by the time, which is twenty hours, and the answer will be five miles an hour. Then, Mrs. B., may we not reverse this rule, and say that the time is equal to the space divided by the velocity; since the space, one hundred miles, divided by the velocity, five miles per hour, gives twenty hours for the time?

Mrs. B. Certainly; and we may say also that the space is equal to the velocity multiplied by the time. Can you tell me, Caroline, how many miles you will have travelled, if your velocity is three miles an hour, and you travel six hours?

Caroline. Eighteen miles; for the product of 3 multiplied by 6, is 18.

Mrs. B. I suppose that you understand what is meant by the terms *uniform*, *accelerated* and *retarded* motion.

Emily. I conceive uniform motion to be that of a body whose motion is regular, and at an equal rate throughout; for instance a horse that goes an equal number of miles every hour. But the hand of a watch is a much better example, as its motion is so regular as to indicate the time.

Mrs. B. You have a right idea of uniform motion; but it would be more correctly expressed by saying, that the motion of a body is uniform when it passes over equal spaces in equal times. Uniform motion is produced by a force having acted on a body once and having ceased to act; as, for instance, the stroke of a bat on a ball.

Caroline. But the motion of a ball is not uniform; its velocity gradually diminishes till it falls to the ground.

Mrs. B. Recollect that the ball is inert, and has no more power to stop, than to put itself in motion; if it falls, therefore, it must be stopped by some force superior to that by which it was projected, and which destroys its motion.

Caroline. And it is no doubt the force of gravity which counteracts and destroys that of projection; but if there were no such power as gravity, would the ball never stop?

Mrs. B. If neither gravity nor any other force, such as the resistance of the air, opposed its motion, the ball, or even a stone thrown by the hand, would proceed onwards in a right line, and with a uniform velocity for ever.

Caroline. You astonish me! I thought that it was impossible to produce perpetual motion?

[Pg 35]

Mrs. B. Perpetual motion cannot be produced by art, because gravity ultimately destroys all motion that human power can produce.

Emily. But independently of the force of gravity, I cannot conceive that the little motion I am

capable of giving to a stone would put it in motion for ever.

Mrs. B. The quantity of motion you communicate to the stone would not influence its duration; if you threw it with little force it would move slowly, for its velocity you must remember, will be proportional to the force with which it is projected; but if there is nothing to obstruct its passage, it will continue to move with the same velocity, and in the same direction as when you first projected it.

Caroline. This appears to me quite incomprehensible; we do not meet with a single instance of it in nature.

Mrs. B. I beg your pardon. When you come to study the motion of the celestial bodies, you will find that *nature* abounds with examples of perpetual motion; and that it conduces as much to the harmony of the system of the universe, as the prevalence of it on the surface of the earth, would to the destruction of all our comforts. The wisdom of Providence has therefore ordained insurmountable obstacles to perpetual motion here below; and though these obstacles often compel us to contend with great difficulties, yet these appear necessary to that order, regularity and repose, so essential to the preservation of all the various beings of which this world is composed.

Now can you tell me what is *retarded motion*?

Caroline. Retarded motion is that of a body which moves every moment slower and slower: thus when I am tired with walking fast, I slacken my pace; or when a stone is thrown upwards, its velocity is gradually diminished by the power of gravity.

Mrs. B. Retarded motion is produced by some force acting upon the body in a direction opposite to that which first put it in motion: you who are an animated being, endowed with power and will, may slacken your pace, or stop to rest when you are tired; but inert matter is incapable of any feeling of fatigue, can never slacken its pace, and never stop, unless retarded or arrested in its course by some opposing force; and as it is the laws of inert bodies of which mechanical philosophy treats, I prefer your illustration of the stone retarded in its ascent. Now Emily, it is your turn; what is *accelerated motion*?

[Pg 36]

Emily. Accelerated motion, I suppose, takes place when the velocity of a body is increased; if you had not objected to our giving such active bodies as ourselves as examples, I should say that my motion is accelerated if I change my pace from walking to running. I cannot think of any instance of accelerated motion in inanimate bodies; all motion of inert matter seems to be retarded by gravity.

Mrs. B. Not in all cases; for the power of gravitation sometimes produces accelerated motion; for instance, a stone falling from a height, moves with a regularly accelerated motion.

Emily. True; because the nearer it approaches the earth, the more it is attracted by it.

Mrs. B. You have mistaken the cause of its accelerated motion; for though it is true that the force of gravity increases as a body approaches the earth, the difference is so trifling at any small distance from its surface, as not to be perceptible.

Accelerated motion is produced when the force which put a body in motion, continues to act upon it during its motion, so that its velocity is continually increased. When a stone falls from a height, the impulse which it receives from gravitation in the first instant of its fall, would be sufficient to bring it to the ground with a uniform velocity: for, as we have observed, a body having been once acted upon by a force, will continue to move with a uniform velocity; but the stone is not acted upon by gravity merely at the first instant of its fall; this power continues to impel it during the whole time of its descent, and it is this continued impulse which accelerates its motion.

Emily. I do not quite understand that.

Mrs. B. Let us suppose that the instant after you have let a stone fall from a high tower, the force of gravity were annihilated; the body would nevertheless continue to move downwards, for it would have received a first impulse from gravity; and a body once put in motion will not stop unless it meets with some obstacle to impede its course; in this case its velocity would be uniform, for though there would be no obstacle to obstruct its descent, there would be no force to accelerate it.

Emily. That is very clear.

Mrs. B. Then you have only to add the power of gravity constantly acting on the stone during its descent, and it will not be difficult to understand that its motion will become accelerated, since the gravity which acts on the stone at the very first instant of its descent, will continue in force every instant, till it reaches the ground. Let us suppose that the impulse given by gravity to the stone during the first instant of its descent, be equal to one; the next instant we shall find that an additional impulse gives the stone an additional velocity, equal to one; so that the accumulated velocity is now equal to two; the following instant another impulse increases the velocity to three, and so on till the stone reaches the ground.

[Pg 37]

Caroline. Now I understand it; the effects of preceding impulses continue, whilst gravity constantly adds new ones, and thus the velocity is perpetually increased.

Mrs. B. Yes; it has been ascertained, both by experiment, and calculations which it would be too

difficult for us to enter into, that heavy bodies near the surface of the earth, descending from a height by the force of gravity, fall sixteen feet the first second of time, three times that distance in the next, five times in the third second, seven times in the fourth, and so on, regularly increasing their velocities in the proportion of the odd numbers 1, 3, 5, 7, 9, &c. according to the number of seconds during which the body has been falling.

Emily. If you throw a stone perpendicularly upwards, is it not the same length of time in ascending, that it is in descending?

Mrs. B. Exactly; in ascending, the velocity is diminished by the force of gravity; in descending, it is accelerated by it.

Caroline. I should then imagine that it would fall, quicker than it rose?

Mrs. B. You must recollect that the force with which it is projected, must be taken into the account; and that this force is overcome and destroyed by gravity, before the body begins to fall.

Caroline. But the force of projection given to a stone in throwing it upwards, cannot always be equal to the force of gravity in bringing it down again; for the force of gravity is always the same, whilst the degree of impulse given to the stone is optional; I may throw it up gently, or with violence.

Mrs. B. If you throw it gently, it will not rise high; perhaps only sixteen feet, in which case it will fall in one second of time. Now it is proved by experiment, that an impulse requisite to project a body sixteen feet upwards, will make it ascend that height in one second; here then the times of the ascent and descent are equal. But supposing it be required to throw a stone twice that height, the force must be proportionally greater.

You see then, that the impulse of projection in throwing a body upwards, is always equal to the action of the force of gravity during its descent; and that whether the body rises to a greater or less distance, these two forces balance each other.

[Pg 38]

I must now explain to you what is meant by the *momentum* of bodies. It is the force, or power, with which a body in motion, strikes against another body. The momentum of a body is the product of its *quantity of matter*, multiplied by its *quantity of motion*; in other words, its weight multiplied by its velocity.

Caroline. The quicker a body moves, the greater, no doubt, must be the force which it would strike against another body.

Emily. Therefore a light body may have a greater momentum than a heavier one, provided its velocity be sufficiently increased; for instance, the momentum of an arrow shot from a bow, must be greater than that of a stone thrown by the hand.

Caroline. We know also by experience, that the heavier a body is, the greater is its force; it is not therefore difficult to understand, that the whole power, or momentum of a body, must be composed of these two properties, its weight and its velocity: but I do not understand why they should be *multiplied*, the one by the other; I should have supposed that the quantity of matter, should have been *added* to the quantity of motion?

Mrs. B. It is found by experiment, that if the weight of a body is represented by the number 3, and its velocity also by 3, its momentum will be represented by 9, not by 6, as would be the case, were these figures added, instead of being multiplied together.

Emily. I think that I now understand the reason of this; if the quantity of matter is increased three-fold, it must require three times the force to move it with the same velocity; and then if we wish to give it three times the velocity, it will again require three times the force to produce that effect, which is three times three, or nine; which number therefore, would represent the momentum.

Caroline. I am not quite sure that I fully comprehend what is intended, when weight, and velocity, are represented by numbers alone; I am so used to measure space by yards and miles, and weight by pounds and ounces, that I still want to associate them together in my mind.

Mrs. B. This difficulty will be of very short duration: you have only to be careful, that when you represent weights and velocities by numbers, the denominations or values of the weights and spaces, must not be changed. Thus, if we estimate the weight of one body in ounces, the weight of others with which it is compared, must be estimated in ounces, and not in pounds; and in like manner, in comparing velocities, we must throughout, preserve the same standards both of space and of time; as for instance, the number of feet in one second, or of miles in one hour.

[Pg 39]

Caroline. I now understand it perfectly, and think that I shall never forget a thing which you have rendered so clear.

Mrs. B. I recommend it to you to be very careful to remember the definition of the momentum of bodies, as it is one of the most important points in mechanics: you will find that it is from opposing velocity, to quantity of matter, that machines derive their powers.

The *reaction* of bodies, is the next law of motion which I must explain to you. When a body in motion strikes against another body, it meets with resistance from it; the resistance of the body at rest will be equal to the blow struck by the body in motion; or to express myself in

philosophical language, *action* and *reaction* will be equal, and in opposite directions.

Caroline. Do you mean to say, that the action of the body which strikes, is returned with equal force by the body which receives the blow?

Mrs. B. Exactly.

Caroline. But if a man strike another on the face with his fist, he surely does not receive as much pain by the reaction, as he inflicts by the blow?

Mrs. B. No; but this is simply owing to the knuckles, having much less feeling than the face.

Here are two ivory balls suspended by threads, ([plate 1. fig. 3.](#)) draw one of them, A, a little on one side,—now let it go;—it strikes, you see, against the other ball B, and drives it off, to a distance equal to that through which the first ball fell; but the motion of A is stopped; because when it struck B, it received in return a blow equal to that it gave, and its motion was consequently destroyed.

Emily. I should have supposed, that the motion of the ball A was destroyed, because it had communicated all its motion to B.

Mrs. B. It is perfectly true, that when one body strikes against another, the quantity of motion communicated to the second body, is lost by the first; but this loss proceeds from the reaction of the body which is struck.

Here are six ivory balls hanging in a row, ([fig. 4.](#)) draw the first out of the perpendicular, and let it fall against the second. You see none of the balls except the last, appear to move, this flies off as far as the first ball fell; can you explain this?

Caroline. I believe so. When the first ball struck the second, it received a blow in return, which destroyed its motion; the second ball, though it did not appear to move, must have struck against the third; the reaction of which set it at rest; the action of the third ball must have been destroyed by the reaction of the fourth, and so on till motion was communicated to the last ball, which, not being reacted upon, flies off.

[Pg 40]

Mrs. B. Very well explained. Observe, that it is only when bodies are elastic, as these ivory balls are, and when their masses are equal, that the stroke returned is equal to the stroke given, and that the striking body loses all its motion. I will show you the difference with these two balls of clay, ([fig. 5.](#)) which are not elastic; when you raise one of these, D, out of the perpendicular, and let it fall against the other, E, the reaction of the latter, on account of its not being elastic, is not sufficient to destroy the motion of the former; only part of the motion of D will be communicated to E, and the two balls will move on together to *d* and *e*, which is not so great a distance as that through which D fell.

Observe how useful reaction is in nature. Birds in flying strike the air with their wings, and it is the reaction of the air, which enables them to rise, or advance forwards; reaction being always in a contrary direction to action.

Caroline. I thought that birds might be lighter than the air, when their wings were expanded, and were by that means enabled to fly.

Mrs. B. When their wings are spread, this does not alter their weight, but they are better supported by the air, as they cover a greater extent of surface; yet they are still much too heavy to remain in that situation, without continually flapping their wings, as you may have noticed when birds hover over their nests: the force with which their wings strike against the air, must equal the weight of their bodies, in order that the reaction of the air, may be able to support that weight; the bird will then remain stationary. If the stroke of the wings is greater than is required merely to support the bird, the reaction of the air will make it rise; if it be less, it will gently descend; and you may have observed the lark, sometimes remaining with its wings extended, but motionless; in this state it drops quietly into its nest.

Caroline. This is indeed a beautiful effect of the law of reaction! But if flying is merely a mechanical operation, Mrs. B., why should we not construct wings, adapted to the size of our bodies, fasten them to our shoulders, move them with our arms, and soar into the air?

[Pg 41]

Mrs. B. Such an experiment has been repeatedly attempted, but never with success; and it is now considered as totally impracticable. The muscular power of birds, is incomparably greater in proportion to their weight, than that of man; were we therefore furnished with wings sufficiently large to enable us to fly, we should not have strength to put them in motion.

In swimming, a similar action is produced on the water, to that on the air, in flying; in rowing, also, you strike the water with the oars, in a direction opposite to that in which the boat is required to move, and it is the reaction of the water on the oars which drives the boat along.

Emily. You said, that it was in elastic bodies only, that the whole motion of one body, would be communicated to another; pray what bodies are elastic, besides the air?

Mrs. B. In speaking of the air, I think we defined elasticity to be a property, by means of which bodies that are compressed, return to their former state. If I bend this cane, as soon as I leave it at liberty, it recovers its former position; if I press my finger upon your arm, as soon as I remove it, the flesh, by virtue of its elasticity, rises and destroys the impression I made. Of all bodies, the

air is the most eminent for this property, and it has thence obtained the name of an elastic fluid. Hard bodies are in the next degree elastic; if two ivory, or hardened steel balls are struck together, the parts at which they touch, will be flattened; but their elasticity will make them instantaneously resume their former shape.

Caroline. But when two ivory balls strike against each other, as they constantly do on a billiard table, no mark or impression is made by the stroke.

Mrs. B. I beg your pardon; you cannot, it is true, perceive any mark, because their elasticity instantly destroys all trace of it.

Soft bodies, which easily retain impressions, such as clay, wax, tallow, butter, &c. have very little elasticity; but of all descriptions of bodies, liquids are the least elastic.

Emily. If sealing-wax were elastic, instead of retaining the impression of a seal, it would resume a smooth surface, as soon as the weight of the seal was removed. But pray what is it that produces the elasticity of bodies?

Mrs. B. There is great diversity of opinion upon that point, and I cannot pretend to decide which approaches nearest to the truth. Elasticity implies susceptibility of compression, and the susceptibility of compression depends upon the porosity of bodies; for were there no pores or spaces between the particles of matter of which a body is composed, it could not be compressed.

[Pg 42]

Caroline. That is to say, that if the particles of bodies were as close together as possible, they could not be squeezed closer.

Emily. Bodies then, whose particles are most distant from each other, must be most susceptible of compression, and consequently most elastic; and this you say is the case with air, which is perhaps the least dense of all bodies?

Mrs. B. You will not in general find this rule hold good; for liquids have scarcely any elasticity, whilst hard bodies are eminent for this property, though the latter are certainly of much greater density than the former; elasticity implies, therefore, not only a susceptibility of compression, but depends upon the power possessed by the body, of resuming its former state after compression, in consequence of the peculiar arrangement of its particles.

Caroline. But surely there can be no pores in ivory and metals, Mrs. B.; how then can they be susceptible of compression?

Mrs. B. The pores of such bodies are invisible to the naked eye, but you must not thence conclude that they have none; it is, on the contrary, well ascertained that gold, one of the most dense of all bodies, is extremely porous; and that these pores are sufficiently large to admit water when strongly compressed, to pass through them. This was shown by a celebrated experiment made many years ago at Florence.

Emily. If water can pass through gold, there must certainly be pores or interstices which afford it a passage; and if gold is so porous, what must other bodies be, which are so much less dense than gold!

Mrs. B. The chief difference in this respect, is I believe, that the pores in some bodies are larger than in others; in cork, sponge and bread, they form considerable cavities; in wood and stone, when not polished, they are generally perceptible to the naked eye; whilst in ivory, metals, and all varnished and polished bodies, they cannot be discerned. To give you an idea of the extreme porosity of bodies, sir Isaac Newton conjectured that if the earth were so compressed as to be absolutely without pores, its dimensions might possibly not be more than a cubic inch.

Caroline. What an idea! Were we not indebted to sir Isaac Newton for the theory of attraction, I should be tempted to laugh at him for such a supposition. What insignificant little creatures we should be!

[Pg 43]

Mrs. B. If our consequence arose from the size of our bodies, we should indeed be but pigmies, but remember that the mind of Newton was not circumscribed by the dimensions of its envelope.

Emily. It is, however, fortunate that heat keeps the pores of matter open and distended, and prevents the attraction of cohesion from squeezing us into a nut-shell.

Mrs. B. Let us now return to the subject of reaction, on which we have some further observations to make. It is because reaction is in its direction opposite to action, that *reflected motion* is produced. If you throw a ball against the wall, it rebounds; this return of the ball is owing to the reaction of the wall against which it struck, and is called *reflected motion*.

Emily. And I now understand why balls filled with air rebound better than those stuffed with bran or wool; air being most susceptible of compression and most elastic, the reaction is more complete.

Caroline. I have observed that when I throw a ball straight against the wall, it returns straight to my hand; but if I throw it obliquely upwards, it rebounds still higher, and I catch it when it falls.

Mrs. B. You should not say straight, but perpendicularly against the wall; for straight is a general term for lines in all directions which are neither curved nor bent, and is therefore equally applicable to oblique or perpendicular lines.

Caroline. I thought that perpendicularly meant either directly upwards or downwards?

Mrs. B. In those directions lines are perpendicular to the earth. A perpendicular line has always a reference to something towards which it is perpendicular; that is to say, that it inclines neither to the one side or the other, but makes an equal angle on every side. Do you understand what an angle is?

Caroline. Yes, I believe so: it is the space contained between two lines meeting in a point.

Mrs. B. Well then, let the line A B (plate 2. fig. 1.) represent the floor of the room, and the line C D that in which you throw a ball against it; the line C D, you will observe, forms two angles with the line A B, and those two angles are equal.

Emily. How can the angles be equal, while the lines which compose them are of unequal length?

Mrs. B. An angle is not measured by the length of the lines, but by their opening, or the space between them. [Pg 44]

Emily. Yet the longer the lines are, the greater is the opening between them.

Mrs. B. Take a pair of compasses and draw a circle over these spaces, making the angular point the centre.

Emily. To what extent must I open the compasses?

Mrs. B. You may draw the circle what size you please, provided that it cuts the lines of the angles we are to measure. All circles, of whatever dimensions, are supposed to be divided into 360 equal parts, called degrees; the opening of an angle, being therefore a portion of a circle, must contain a certain number of degrees: the larger the angle the greater is the number of degrees, and two angles are said to be equal, when they contain an equal number of degrees.

Emily. Now I understand it. As the dimension of an angle depends upon the number of degrees contained between its lines, it is the opening, and not the length of its lines, which determines the size of the angle.

Mrs. B. Very well: now that you have a clear idea of the dimensions of angles, can you tell me how many degrees are contained in the two angles formed by one line falling perpendicularly on another, as in the figure I have just drawn?

Emily. You must allow me to put one foot of the compasses at the point of the angles, and draw a circle round them, and then I think I shall be able to answer your question: the two angles are together just equal to half a circle, they contain therefore 90 degrees each; 90 degrees being a quarter of 360.

Mrs. B. An angle of 90 degrees or one-fourth of a circle is called a right angle, and when one line is perpendicular to another, and distant from its ends, it forms, you see, (fig. 1.) a right angle on either side. Angles containing more than 90 degrees are called obtuse angles, (fig. 2.) and those containing less than 90 degrees are called acute angles, (fig. 3.)

Caroline. The angles of this square table are right angles, but those of the octagon table are obtuse angles; and the angles of sharp pointed instruments are acute angles.

PLATE II.

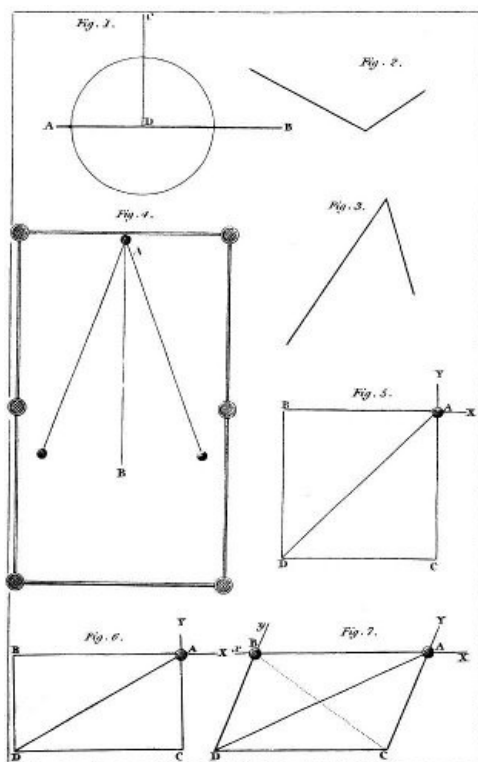

Caroline. Yes, frequently; and I have observed that when I push the ball perpendicularly against the cushion, it returns in the same direction; but when I send it obliquely to the cushion, it rebounds obliquely, but on an opposite side; the ball in this latter case describes an angle, the point of which is at the cushion. I have observed too, that the more obliquely the ball is struck against the cushion, the more obliquely it rebounds on the opposite side, so that a billiard player can calculate with great accuracy in what direction it will return.

Mrs. B. Very well. This figure ([fig. 4. plate 2.](#)) represents a billiard table; now if you draw a line A B from the point where the ball A strikes perpendicular to the cushion, you will find that it will divide the angle which the ball describes into two parts, or two angles; the one will show the obliquity of the direction of the ball in its passage towards the cushion, the other its obliquity in its passage back from the cushion. The first is called *the angle of incidence*, the other *the angle of reflection*; and these angles are always equal, if the bodies are perfectly elastic.

Caroline. This then is the reason why, when I throw a ball obliquely against the wall, it rebounds in an opposite oblique direction, forming equal angles of incidence and of reflection.

Mrs. B. Certainly; and you will find that the more obliquely you throw the ball, the more obliquely it will rebound.

We must now conclude; but I shall have some further observations to make upon the laws of motion, at our next meeting.

Questions

1. (Pg. [32](#)) On what is the science of mechanics founded?
2. (Pg. [32](#)) In what does motion consist?
3. (Pg. [33](#)) What is the consequence of inertia, on a body at rest?
4. (Pg. [33](#)) What do we call that which produces motion?
5. (Pg. [33](#)) Give some examples.
6. (Pg. [33](#)) What may we say of gravity, of cohesion, and of heat, as forces?
7. (Pg. [33](#)) How will a body move, if acted on by a single force?
8. (Pg. [33](#)) What is the reason of this?
9. (Pg. [33](#)) What do we intend by the term velocity, and to what is it proportional?
10. (Pg. [33](#)) Velocity is divided into absolute and relative; what is meant by absolute velocity?
11. (Pg. [33](#)) How is relative velocity distinguished?
12. (Pg. [34](#)) How do we measure the velocity of a body?
13. (Pg. [34](#)) The time?
14. (Pg. [34](#)) The space?
15. (Pg. [34](#)) What is uniform motion? and give an example.
16. (Pg. [34](#)) How is uniform motion produced?
17. (Pg. [34](#)) A ball struck by a bat gradually loses its motion; what causes produce this effect?
18. (Pg. [35](#)) If gravity did not draw a projected body towards the earth, and the resistance of the air were removed, what would be the consequence?
19. (Pg. [35](#)) In this case would not a great degree of force be required to produce a continued motion?
20. (Pg. [35](#)) What is retarded motion?
21. (Pg. [35](#)) Give some examples.
22. (Pg. [36](#)) What is accelerated motion?
23. (Pg. [36](#)) Give an example.
24. (Pg. [36](#)) Explain the mode in which gravity operates in producing this effect.
25. (Pg. [37](#)) What number of feet will a heavy body descend in the first second of its fall, and at what rate will its velocity increase?
26. (Pg. [37](#)) What is the difference in the time of the ascent and descent, of a stone, or other body thrown upwards?
27. (Pg. [37](#)) By what reasoning is it proved that there is no difference?
28. (Pg. [38](#)) What is meant by the momentum of a body?
29. (Pg. [38](#)) How do we ascertain the momentum?
30. (Pg. [38](#)) How may a light body have a greater momentum than one which is heavier?
31. (Pg. [38](#)) Why must we *multiply* the weight and velocity together in order to find the momentum?
32. (Pg. [39](#)) When we represent weight and velocity by numbers, what must we carefully observe?
33. (Pg. [39](#)) Why is it particularly important, to understand the nature of momentum?
34. (Pg. [39](#)) What is meant by reaction, and what is the rule respecting it?
35. (Pg. [39](#)) How is this exemplified by the ivory balls represented in [plate 1. fig. 3?](#)
36. (Pg. [40](#)) Explain the manner in which the six balls represented in [fig. 4.](#) illustrate this fact.
37. (Pg. [40](#)) What must be the nature of bodies, in which the whole motion is communicated from one to the other?
38. (Pg. [40](#)) What is the result if the balls are not elastic, and how is this explained by [fig. 5?](#)
39. (Pg. [40](#)) How will reaction assist us in explaining the flight of a bird?
40. (Pg. [40](#)) How must their wings operate in enabling them to remain stationary, to rise, and to descend?
41. (Pg. [41](#)) Why cannot a man fly by the aid of wings?
42. (Pg. [41](#)) How does reaction operate in enabling us to swim, or to row a boat?
43. (Pg. [41](#)) What constitutes elasticity?

44. (Pg. 41) Give some examples.
45. (Pg. 41) What name is given to air, and for what reason?
46. (Pg. 41) What hard bodies are mentioned as elastic?
47. (Pg. 41) Do elastic bodies exhibit any indentation after a blow? and why not?
48. (Pg. 42) What do we conclude from elasticity respecting the contact of the particles of a body?
49. (Pg. 42) Are those bodies always the most elastic, which are the least dense?
50. (Pg. 42) Give examples to prove that this is not the case.
51. (Pg. 42) All bodies are believed to be porous, what is said on this subject respecting gold?
52. (Pg. 43) What conjecture was made by sir Isaac Newton, respecting the porosity of bodies in general?
53. (Pg. 43) If you throw an elastic body against a wall, it will rebound; what is this occasioned by, and what is this return motion called?
54. (Pg. 43) What do we mean by a perpendicular line?
55. (Pg. 43) What is an angle?
56. (Pg. 43) What is represented by [fig. 1. plate 2](#)?
57. (Pg. 44) Have the length of the lines which meet in a point, any thing to do with the measurement of an angle?
58. (Pg. 44) What use can we make of compasses in measuring an angle?
59. (Pg. 44) Into what number of parts do we suppose a whole circle divided, and what are these parts called?
60. (Pg. 44) When are two angles said to be equal?
61. (Pg. 44) Upon what does the dimension of an angle depend?
62. (Pg. 44) What number of degrees, and what portion of a circle is there in a right angle?
63. (Pg. 44) How must one line be situated on another to form two right angles? ([fig. 1.](#))
64. (Pg. 44) [Figure 2](#) represents an angle of more than 90 degrees, what is that called?
65. (Pg. 44) What are those of less than 90 degrees called as in [fig. 3](#)?
66. (Pg. 45) If you make an elastic ball strike a body at right angles, how will it return?
67. (Pg. 45) How if it strikes obliquely?
68. (Pg. 45) Explain by [fig. 4](#) what is meant by the angles of incidence and of reflection.

CONVERSATION IV. ON COMPOUND MOTION.

[Pg 46]

COMPOUND MOTION, THE RESULT OF TWO OPPOSITE FORCES. OF CURVILINEAR MOTION, THE RESULT OF TWO FORCES. CENTRE OF MOTION, THE POINT AT REST WHILE THE OTHER PARTS OF THE BODY MOVE ROUND IT. CENTRE OF MAGNITUDE, THE MIDDLE OF A BODY. CENTRIPETAL FORCE, THAT WHICH IMPELS A BODY TOWARDS A FIXED CENTRAL POINT. CENTRIFUGAL FORCE, THAT WHICH IMPELS A BODY TO FLY FROM THE CENTRE. FALL OF BODIES IN A PARABOLA. CENTRE OF GRAVITY, THE POINT ABOUT WHICH THE PARTS BALANCE EACH OTHER.

MRS. B.

I must now explain to you the nature of compound motion. Let us suppose a body to be struck by two equal forces in opposite directions, how will it move?

Emily. If the forces are equal, and their directions are in exact opposition to each other, I suppose the body would not move at all.

Mrs. B. You are perfectly right; but suppose the forces instead of acting upon the body in direct opposition to each other, were to move in lines forming an angle of ninety degrees, as the lines Y A, X A, ([fig. 5. plate 2.](#)) and were to strike the ball A, at the same instant; would it not move?

Emily. The force X alone, would send it towards B, and the force Y towards C; and since these forces are equal, I do not know how the body can obey one impulse rather than the other; and yet I think the ball would move, because as the two forces do not act in direct opposition, they cannot entirely destroy the effect of each other.

Mrs. B. Very true; the ball therefore will not follow the direction of either of the forces, but will move in a line between them, and will reach D in the same space of time, that the force X would have sent it to B, and the force Y would have sent it to C. Now if you draw two lines, one from B, parallel to A C, and the other from C, parallel to A B, they will meet in D, and you will form a square; the oblique line which the body describes, is called the diagonal of the square.

[Pg 47]

Caroline. That is very clear, but supposing the two forces to be unequal, that the force X, for instance, be twice as great as the force Y?

Mrs. B. Then the force X, would drive the ball twice as far as the force Y, consequently you must draw the line A B ([fig. 6.](#)) twice as long as the line A C, the body will in this case move to D; and if you draw lines from the points B and C, exactly as directed in the last example, they will meet in

D, and you will find that the ball has moved in the diagonal of a rectangle.

Emily. Allow me to put another case. Suppose the two forces are unequal, but do not act on the ball in the direction of a right angle, but in that of an acute angle, what will result?

Mrs. B. Prolong the lines in the directions of the two forces, and you will soon discover which way the ball will be impelled; it will move from A to D, in the diagonal of a parallelogram, ([fig. 7.](#)) Forces acting in the direction of lines forming an obtuse angle, will also produce motion in the diagonal of a parallelogram. For instance, if the body set out from B, instead of A, and was impelled by the forces X and Y, it would move in the dotted diagonal B C.

We may now proceed to curvilinear motion: this is the result of two forces acting on a body; by one of which, it is projected forward in a right line; whilst by the other, it is drawn or impelled towards a fixed point. For instance, when I whirl this ball, which is fastened to my hand with a string, the ball moves in a circular direction, because it is acted on by two forces; that which I give it, which represents the force of projection, and that of the string which confines it to my hand. If, during its motion you were suddenly to cut the string, the ball would fly off in a straight line; being released from that confinement which caused it to move round a fixed point, it would be acted on by one force only; and motion produced by one force, you know, is always in a right line.

Caroline. This circular motion, is a little more difficult to comprehend than compound motion in straight lines.

Mrs. B. You have seen how the water is thrown off from a grindstone, when turned rapidly round; the particles of the stone itself have the same tendency, and would also fly off, was not their attraction of cohesion, greater than that of water. And indeed it sometimes happens, that large grindstones fly to pieces from the rapidity of their motion.

[Pg 48]

Emily. In the same way, the rim and spokes of a wheel, when in rapid motion, would be driven straight forwards in a right line, were they not confined to a fixed point, round which they are compelled to move.

Mrs. B. Very well. You must now learn to distinguish between what is called the *centre* of motion, and the *axis* of motion; the former being considered as a point, the latter as a line.

When a body, like the ball at the end of the string, revolves in a circle, the centre of the circle is called the centre of its motion, and the body is said to revolve in a plane; because a line extended from the revolving body, to the centre of motion, would describe a plane, or flat surface.

When a body revolves round itself, as a ball suspended by a string, and made to spin round, or a top spinning on the floor, whilst it remains on the same spot; this revolution is round an imaginary line passing through the body, and this line is called its axis of motion.

Caroline. The axle of a grindstone, is then the axis of its motion; but is the centre of motion always in the middle of a body?

Mrs. B. No, not always. The middle point of a body, is called its centre of magnitude, or position, that is, the centre of its mass or bulk. Bodies have also another centre, called the centre of gravity, which I shall explain to you; but at present we must confine ourselves to the axis of motion. This line you must observe remains at rest, whilst all the other parts of the body move around it; when you spin a top, the axis is stationary, whilst every other part is in motion round it.

Caroline. But a top generally has a motion forwards besides its spinning motion; and then no point within it can be at rest?

Mrs. B. What I say of the axis of motion, relates only to circular motion; that is to say, motion round a line, and not to that which a body may have at the same time in any other direction. There is one circumstance to which you must carefully attend; namely, that the further any part of a body is from the axis of motion, the greater is its velocity: as you approach that line, the velocity of the parts gradually diminish till you reach the axis of motion, which is perfectly at rest.

Caroline. But, if every part of the same body did not move with the same velocity, that part which moved quickest, must be separated from the rest of the body, and leave it behind?

[Pg 49]

Mrs. B. You perplex yourself by confounding the idea of circular motion, with that of motion in a right line; you must think only of the motion of a body round a fixed line, and you will find, that if the parts farthest from the centre had not the greatest velocity, those parts would not be able to keep up with the rest of the body, and would be left behind. Do not the extremities of the vanes of a windmill move over a much greater space, than the parts nearest the axis of motion? ([plate 3. fig. 1.](#)) The three dotted circles represent the paths in which three different parts of the vanes move, and though the circles are of different dimensions, each of them is described in the same space of time.

Caroline. Certainly they are; and I now only wonder, that we neither of us ever made the observation before: and the same effect must take place in a solid body, like the top in spinning; the most bulging part of the surface must move with the greatest rapidity.

Mrs. B. The force which draws a body towards a centre, round which it moves, is called the *centripetal* force; and that force, which impels a body to fly from the centre, is called the *centrifugal* force; when a body revolves round a centre, these two forces constantly balance each

other; otherwise the revolving body would either approach the centre or recede from it, according as the one or the other prevailed.

Caroline. When I see any body moving in a circle, I shall remember, that it is acted on by two forces.

Mrs. B. Motion, either in a circle, an ellipsis, or any other curve-line, must be the result of the action of two forces; for you know, that the impulse of one single force, always produces motion in a right line.

Emily. And if any cause should destroy the centripetal force, the centrifugal force would alone impel the body, and it would, I suppose, fly off in a straight line from the centre to which it had been confined.

Mrs. B. It would not fly off in a right line from the centre; but in a right line in the direction in which it was moving, at the instant of its release; if a stone, whirled round in a sling, gets loose at the point A, ([plate 3. fig. 2.](#)) it flies off in the direction A B; this line is called a *tangent*, it touches the circumference of the circle, and forms a right angle with a line drawn from that point of the circumference to the centre of the circle C.

[Pg 50]

Emily. You say, that motion in a curve-line, is owing to two forces acting upon a body; but when I throw this ball in a horizontal direction, it describes a curve-line in falling; and yet it is only acted upon by the force of projection; there is no centripetal force to confine it, or produce compound motion.

Mrs. B. A ball thus thrown, is acted upon by no less than three forces; the force of projection, which you communicate to it; the resistance of the air through which it passes, which diminishes its velocity, without changing its direction; and the force of gravity, which finally brings it to the ground. The power of gravity, and the resistance of the air, being always greater than any force of projection we can give a body, the latter is gradually overcome, and the body brought to the ground; but the stronger the projectile force, the longer will these powers be in subduing it, and the further the body will go before it falls.

Caroline. A shot fired from a cannon, for instance, will go much further, than a stone projected by the hand.

Mrs. B. Bodies thus projected, you observe, describe a curve-line in their descent; can you account for that?

Caroline. No; I do not understand why it should not fall in the diagonal of a square.

Mrs. B. You must consider that the force of projection is strongest when the ball is first thrown; this force, as it proceeds, being weakened by the continued resistance of the air, the stone, therefore, begins by moving in a horizontal direction; but as the stronger powers prevail, the direction of the ball will gradually change from a horizontal, to a perpendicular line. *Projection* alone, would drive the ball A, to B, ([fig. 3.](#)) *gravity* would bring it to C; therefore, when acted on in different directions, by these two forces, it moves between, gradually inclining more and more to the force of gravity, in proportion as this accumulates; instead therefore of reaching the ground at D, as you suppose it would, it falls somewhere about E.

Caroline. It is precisely so; look Emily, as I throw this ball directly upwards, how gravity and the resistance of the air conquer projection. Now I will throw it upwards obliquely: see, the force of projection enables it, for an instant, to act in opposition to that of gravity; but it is soon brought down again.

Mrs. B. The curve-line which the ball has described, is called in geometry a *parabola*; but when the ball is thrown perpendicularly upwards, it will descend perpendicularly; because the force of projection, and that of gravity, are in the same line of direction.

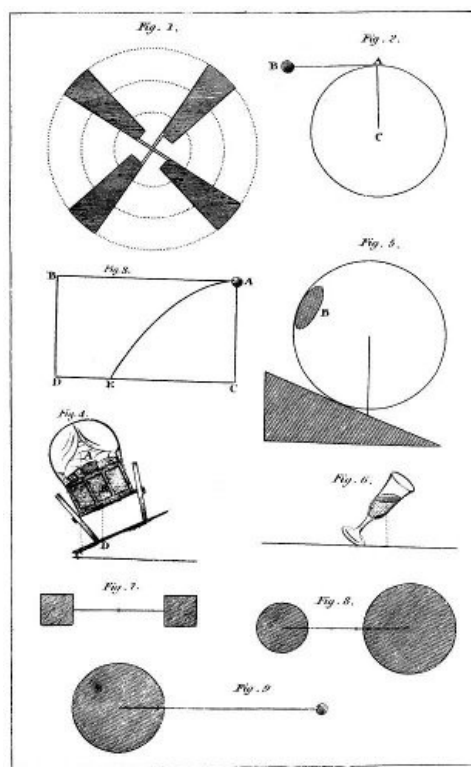

We have noticed the centres of magnitude, and of motion; but I have not yet explained to you, what is meant by the *centre of gravity*; it is that point in a body, about which all the parts exactly balance each other; if therefore that point be supported, the body will not fall. Do you understand this? [Pg 51]

Emily. I think so; if the parts round about this point have an equal tendency to fall, they will be in equilibrium, and as long as this point is supported, the body cannot fall.

Mrs. B. Caroline, what would be the effect, were the body supported in any other single point?

Caroline. The surrounding parts no longer balancing each other, the body, I suppose, would fall on the side at which the parts are heaviest.

Mrs. B. Infallibly; whenever the centre of gravity is unsupported, the body must fall. This sometimes happens with an overloaded wagon winding up a steep hill, one side of the road being more elevated than the other; let us suppose it to slope as is described in this figure, ([plate 3. fig. 4.](#)) we will say, that the centre of gravity of this loaded wagon is at the point A. Now your eye will tell you, that a wagon thus situated, will overset; and the reason is, that the centre of gravity A, is not supported; for if you draw a perpendicular line from it to the ground at C, it does not fall under the wagon within the wheels, and is therefore not supported by them.

Caroline. I understand that perfectly; but what is the meaning of the other point B?

Mrs. B. Let us, in imagination take off the upper part of the load; the centre of gravity will then change its situation, and descend to B, as that will now be the point about which the parts of the less heavily laden wagon will balance each other. Will the wagon now be upset?

Caroline. No, because a perpendicular line from that point falls within the wheels at D, and is supported by them; and when the centre of gravity is supported, the body will not fall.

Emily. Yet I should not much like to pass a wagon in that situation, for, as you see, the point D is but just within the left wheel; if the right wheel was raised, by merely passing over a stone, the point D would be thrown on the outside of the left wheel, and the wagon would upset.

Caroline. A wagon, or any carriage whatever, will then be most firmly supported, when the centre of gravity falls exactly between the wheels; and that is the case in a level road. [Pg 52]

Mrs. B. The centre of gravity of the human body, is a point somewhere in a line extending perpendicularly through the middle of it, and as long as we stand upright, this point is supported by the feet; if you lean on one side, you will find that you no longer stand firm. A rope-dancer performs all his feats of agility, by dexterously supporting his centre of gravity; whenever he finds that he is in danger of losing his balance, he shifts the heavy pole which he holds in his hands, in order to throw the weight towards the side that is deficient; and thus by changing the situation of the centre of gravity, he restores his equilibrium.

Caroline. When a stick is poised on the tip of the finger, is it not by supporting its centre of gravity?

Mrs. B. Yes; and it is because the centre of gravity is not supported, that spherical bodies roll down a slope. A sphere being perfectly round, can touch the slope but by a single point, and that point cannot be perpendicularly under the centre of gravity, and therefore cannot be supported, as you will perceive by examining this figure. ([fig. 5. plate 3.](#))

Emily. So it appears: yet I have seen a cylinder of wood roll up a slope; how is that contrived?

Mrs. B. It is done by plugging or loading one side of the cylinder with lead, as at B, ([fig. 5. plate 3.](#)) the body being no longer of a uniform density, the centre of gravity is removed from the middle of the body to some point in or near the lead, as that substance is much heavier than wood; now you may observe that should this cylinder roll down the plane, as it is here situated, the centre of gravity must rise, which is impossible; the centre of gravity must always descend in moving, and will descend by the nearest and readiest means, which will be by forcing the cylinder up the slope, until the centre of gravity is supported, and then it stops.

Caroline. The centre of gravity, therefore, is not always in the middle of a body.

Mrs. B. No, that point we have called the centre of magnitude; when the body is of an uniform density, and of a regular form, as a cube, or sphere, the centres of gravity and of magnitude are in the same point; but when one part of the body is composed of heavier materials than another, the centre of gravity can no longer correspond with the centre of magnitude. Thus you see the centre of gravity of this cylinder plugged with lead, cannot be in the same spot as the centre of magnitude.

[Pg 53]

Emily. Bodies, therefore, consisting but of one kind of substance, as wood, stone, or lead, and whose densities are consequently uniform, must stand more firmly, and be more difficult to overset, than bodies composed of a variety of substances, of different densities, which may throw the centre of gravity on one side.

Mrs. B. That depends upon the situation of the materials; if those which are most dense, occupy the lower part, the stability will be increased, as the centre of gravity will be near the base. But there is another circumstance which more materially affects the firmness of their position, and that is their form. Bodies that have a narrow base are easily upset, for if they are a little inclined, their centre of gravity is no longer supported, as you may perceive in [fig. 6.](#)

Caroline. I have often observed with what difficulty a person carries a single pail of water; it is owing, I suppose, to the centre of gravity being thrown on one side; and the opposite arm is stretched out to endeavour to bring it back to its original situation; but a pail hanging to each arm is carried with less difficulty, because they balance each other, and the centre of gravity remains supported by the feet.

Mrs. B. Very well; I have but one more remark to make on the centre of gravity, which is, that when two bodies are fastened together by an inflexible rod, they are to be considered as forming but one body; if the two bodies be of equal weight, the centre of gravity will be in the middle of the line which unites them, ([fig. 7.](#)) but if one be heavier than the other, the centre of gravity will be proportionally nearer the heavy body than the light one. ([fig. 8.](#)) If you were to carry a rod or pole with an equal weight fastened at each end of it, you would hold it in the middle of the rod, in order that the weights should balance each other; whilst if the weights were unequal, you would hold it nearest the greater weight, to make them balance each other.

Emily. And in both cases we should support the centre of gravity; and if one weight be very considerably larger than the other, the centre of gravity will be thrown out of the rod into the heaviest weight. ([fig. 9.](#))

Mrs. B. Undoubtedly.

Questions

1. (Pg. [46](#)) If a body be struck by two equal forces in opposite directions, what will be the result?
2. (Pg. [46](#)) What is [fig. 5. plate 2.](#) intended to represent?
3. (Pg. [47](#)) How would the ball move, and how would you represent the direction of its motion?
4. (Pg. [47](#)) What is supposed respecting the forces represented in [fig. 6?](#)
5. (Pg. [47](#)) How would the body move if so impelled?
6. (Pg. [47](#)) If the forces are unequal and not at right angles, how would the body move, as illustrated by [fig. 7?](#)
7. (Pg. [47](#)) How must a body be acted on, to produce motion in a curve, and what example is given?
8. (Pg. [48](#)) When is a body said to revolve in a plane, and what is meant by the centre of motion?
9. (Pg. [48](#)) What is intended by the axis of motion, and what are examples?
10. (Pg. [48](#)) What is the middle point of a body called?
11. (Pg. [48](#)) What is said of the axis of motion, whilst the body is revolving?
12. (Pg. [48](#)) When a body revolves on an axis, do all its parts move with equal velocity?
13. (Pg. [49](#)) How is this explained by [fig. 1. plate 3?](#)
14. (Pg. [49](#)) What are the two forces called which cause a body to move in a curve; and what proportion do these two forces bear to each other when a body revolves round a centre?
15. (Pg. [49](#)) If the centripetal force were destroyed, how would a body be carried by the centrifugal?
16. (Pg. [50](#)) Explain what is meant by a *tangent*, as shown in [fig. 2. plate 3.](#)
17. (Pg. [50](#)) What forces impede a body thrown horizontally?
18. (Pg. [50](#)) Give the reason why a body so projected, falls in a curve. ([fig. 3. plate 3.](#))
19. (Pg. [51](#)) The curve in which it falls, is not a part of a true circle: what is it denominated?
20. (Pg. [51](#)) What is the *centre of gravity* defined to be?
21. (Pg. [51](#)) What results from supporting, or not supporting the centre of gravity?

22. (Pg. 51) What is intended to be explained by [fig. 4. plate 3](#)?
23. (Pg. 51) What would be the effect of taking off the upper portion of the load?
24. (Pg. 52) When will a carriage stand most firmly?
25. (Pg. 52) What is said of the centre of gravity of the human body, and how does a rope dancer preserve his equilibrium?
26. (Pg. 52) Why cannot a sphere remain at rest on an inclined plane? ([fig. 5. plate 3.](#))
27. (Pg. 52) A cylinder of wood, may be made to rise to a small distance up an inclined plane. How may this be effected? ([fig. 5. plate 3.](#))
28. (Pg. 53) When do we find the centres of gravity, and of magnitude in different points?
29. (Pg. 53) What influence will the density of the parts of a body exert upon its stability?
30. (Pg. 53) What other circumstance materially affects the firmness of position? ([fig. 6. plate 3.](#))
31. (Pg. 53) Why is it more easy to carry a weight in each hand, than in one only?
32. (Pg. 53) What is said respecting two bodies united by an inflexible rod?
33. (Pg. 53) What is [fig. 7. plate 3.](#) intended to illustrate? What [fig. 8.](#); what [fig. 9.](#)?

CONVERSATION V. ON THE MECHANICAL POWERS.

[Pg 54]

OF THE POWER OF MACHINES. OF THE LEVER IN GENERAL. OF THE LEVER OF THE FIRST KIND, HAVING THE FULCRUM BETWEEN THE POWER AND THE WEIGHT. OF THE LEVER OF THE SECOND KIND, HAVING THE WEIGHT BETWEEN THE POWER AND THE FULCRUM. OF THE LEVER OF THE THIRD KIND, HAVING THE POWER BETWEEN THE FULCRUM AND THE WEIGHT.

MRS. B.

We may now proceed to examine the mechanical powers; they are six in number: The *lever*, the *pulley*, the *wheel* and *axle*, the *inclined plane*, the *wedge* and the *screw*; one or more of which enters into the composition of every machine.

A mechanical power is an instrument by which the effect of a given force is increased, whilst the force remains the same.

In order to understand the power of a machine, there are four things to be considered. 1st. The power that acts: this consists in the effort of men or horses, of weights, springs, steam, &c.

2dly. The resistance which is to be overcome by the power: this is generally a weight to be moved. The power must always be superior to the resistance, otherwise the machine could not be put in motion.

Caroline. If for instance the resistance of a carriage was greater than the strength of the horses employed to draw it, they would not be able to make it move.

Mrs. B. 3dly. We are to consider the support or prop, or as it is termed in mechanics, the *fulcrum*; this you may recollect is the point upon which the body turns when in motion; and lastly, the respective velocities of the power, and of the resistance.

Emily. That must in general depend upon their respective distances from the fulcrum, or from the axis of motion; as we observed in the motion of the vanes of the windmill.

Mrs. B. We shall now examine the power of the lever. The *lever is an inflexible rod or bar, moveable about a fulcrum, and having forces applied to two or more points on it.* For instance, the steel rod to which these scales are suspended is a lever, and the point in which it is supported, the fulcrum, or centre of motion; now, can you tell me why the two scales are in equilibrium? [Pg 55]

Caroline. Being both empty, and of the same weight, they balance each other.

Emily. Or, more correctly speaking, because the centre of gravity common to both, is supported.

Mrs. B. Very well; and where is the centre of gravity of this pair of scales? ([fig. 1. plate 4.](#))

Emily. You have told us that when two bodies of equal weight were fastened together, the centre of gravity was in the middle of the line that connected them; the centre of gravity of the scales must therefore be supported by the fulcrum F of the lever which unites the two scales, and which is the centre of motion.

Caroline. But if the scales contained different weights, the centre of gravity would no longer be in the fulcrum of the lever, but remove towards that scale which contained the heaviest weight; and since that point would no longer be supported, the heavy scale would descend, and out-weigh the other.

Mrs. B. True; but tell me, can you imagine any mode by which bodies of different weights can be

made to balance each other, either in a pair of scales, or simply suspended to the extremities of the lever? for the scales are not an essential part of the machine; they have no mechanical power, and are used merely for the convenience of containing the substance to be weighed.

Caroline. What! make a light body balance a heavy one? I cannot conceive that possible.

Mrs. B. The fulcrum of this pair of scales ([fig. 2.](#)) is moveable, you see; I can take it off the beam, and fasten it on again in another part; this part is now become the fulcrum, but it is no longer in the centre of the lever.

Caroline. And the scales are no longer true; for that which hangs on the longest side of the lever descends.

Mrs. B. The two parts of the lever divided by the fulcrum, are called its arms; you should therefore say the longest arm, not the longest side of the lever.

Your observation is true that the balance is now destroyed; but it will answer the purpose of enabling you to comprehend the power of a lever, when the fulcrum is not in the centre.

Emily. This would be an excellent contrivance for those who cheat in the weight of their goods; by making the fulcrum a little on one side, and placing the goods in the scale which is suspended to the longest arm of the lever, they would appear to weigh more than they do in reality.

[Pg 56]

Mrs. B. You do not consider how easily the fraud would be detected; for on the scales being emptied they would not hang in equilibrium. If indeed the scale on the shorter arm was made heavier, so as to balance that on the longer, they would appear to be true, whilst they were really false.

Emily. True; I did not think of that circumstance. But I do not understand why the longest arm of the lever should not be in equilibrium with the other?

Caroline. It is because the momentum in the longest, is greater than in the shortest arm; the centre of gravity, therefore, is no longer supported.

Mrs. B. You are right, the fulcrum is no longer in the centre of gravity; but if we can contrive to make the fulcrum in its present situation become the centre of gravity, the scales will again balance each other; for you recollect that the centre of gravity is that point about which every part of the body is in equilibrium.

Emily. It has just occurred to me how this may be accomplished; put a great weight into the scale suspended to the shortest arm of the lever, and a smaller one into that suspended to the longest arm. Yes, I have discovered it—look Mrs. B., the scale on the shortest arm will carry 3 lbs., and that on the longest arm only one, to restore the balance. ([fig. 3.](#))

Mrs. B. You see, therefore, that it is not so impracticable as you imagined, to make a heavy body balance a light one; and this is in fact the means by which you observed that an imposition in the weight of goods might be effected, as a weight of ten or twelve ounces, might thus be made to balance a pound of goods. If you measure both arms of the lever, you will find that the length of the longer arm, is three times that of the shorter; and that to produce an equilibrium, the weights must bear the same proportion to each other, and that the greater weight, must be on the shorter arm. Let us now take off the scales, that we may consider the lever simply; and in this state you see that the fulcrum is no longer the centre of gravity, because it has been removed from the middle of the lever; but it is, and must ever be, the centre of motion, as it is the only point which remains at rest, while the other parts move about it.

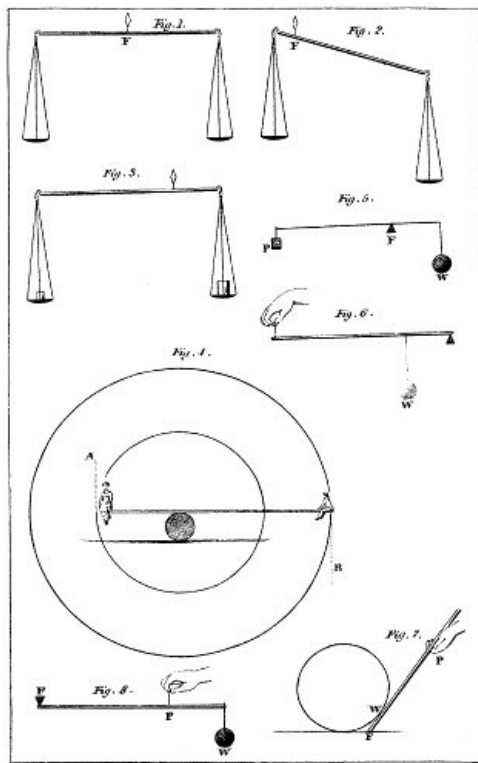

Caroline. The arms of the lever being different in length, it now exactly resembles the steelyards, with which articles are so frequently weighed. [Pg 57]

Mrs. B. It may in fact be considered as a pair of steelyards, by which the same power enables us to ascertain the weight of different articles, by simply increasing the distance of the power from the fulcrum; you know that the farther a body is from the axis of motion, the greater is its velocity.

Caroline. That I remember, and understand perfectly.

Mrs. B. You comprehend then, that the extremity of the longest arm of a lever, must move with greater velocity than that of the shortest arm, and that its momentum is greater in proportion.

Emily. No doubt, because it is farthest from the centre of motion. And pray, Mrs. B., when my brothers play at *see-saw*, is not the plank on which they ride, a kind of lever?

Mrs. B. Certainly; the log of wood which supports it from the ground is the fulcrum, and those who ride, represent the power and the resistance at the ends of the lever. And have you not observed that when those who ride are of equal weight, the plank must be supported in the middle, to make the two arms equal; whilst if the persons differ in weight, the plank must be drawn a little farther over the prop, to make the arms unequal, and the lightest person, who may be supposed to represent the power, must be placed at the extremity of the longest arm.

Caroline. That is always the case when I ride on a plank with my youngest brother; I have observed also that the lightest person has the best ride, as he moves both further and quicker; and I now understand that it is because he is more distant from the centre of motion.

Mrs. B. The greater velocity with which your little brother moves, renders his momentum equal to yours.

Caroline. Yes; I have the most weight, he the greatest velocity; so that upon the whole our momentums are equal. But you said, Mrs. B., that the power should be greater than the resistance, to put the machine in motion; how then can the plank move if the momentums of the persons who ride are equal?

Mrs. B. Because each person at his descent touches and pushes against the ground with his feet; the reaction of which gives him an impulse which produces the motion; this spring is requisite to destroy the equilibrium of the power and the resistance, otherwise the plank would not move. Did you ever observe that a lever describes the arc of a circle in its motion?

Emily. No; it appears to me to rise and descend perpendicularly; at least I always thought so. [Pg 58]

Mrs. B. I believe I must make a sketch of you and your brother riding on a plank, in order to convince you of your error. (fig. 4. plate 4.) You may now observe that a lever can move only round the fulcrum, since that is the centre of motion; it would be impossible for you to rise perpendicularly, to the point A; or for your brother to descend in a straight line, to the point B; you must in rising, and he in descending, describe arcs of your respective circles. This drawing shows you also how much superior his velocity must be to yours; for if you could swing quite round, you would each complete your respective circles, in the same time.

Caroline. My brother's circle being much the largest, he must undoubtedly move the quickest.

Mrs. B. Now tell me, do you think that your brother could raise you as easily without the aid of a lever?

Caroline. Oh no, he could not lift me off the ground.

Mrs. B. Then I think you require no further proof of the power of a lever, since you see what it enables your brother to perform.

Caroline. I now understand what you meant by saying, that in mechanics, velocity is opposed to weight, for it is my brother's velocity which overcomes my weight.

Mrs. B. You may easily imagine, what enormous weights may be raised by levers of this description, for the longer, when compared with the other, that arm is to which the power is applied, the greater will be the effect produced by it; because the greater is the velocity of the power compared to that of the weight.

Lever is of three kinds; in the first the fulcrum is between the power and the weight.

Caroline. This kind then comprehends the several levers you have described.

Mrs. B. Yes, when in levers of the first kind, the fulcrum is equally distant from the power and the weight, as in the balance, there will be an equilibrium, when the power and the weight are equal to each other; it is not then a mechanical power, for nothing can in this case be gained by velocity; the two arms of the lever being equal, the velocity of their extremities must be so likewise. The balance is therefore of no assistance as a mechanical power, although it is extremely useful in estimating the respective weights of bodies.

But when ([fig. 5.](#)) the fulcrum F of a lever is not equally distant from the power and the weight, and the power P acts at the extremity of the longest arm, it may be less than the weight W; its deficiency being compensated by its superior velocity, as we observed in the *see-saw*.

[Pg 59]

Emily. Then when we want to lift a great weight, we must fasten it to the shortest arm of a lever, and apply our strength to the longest arm?

Mrs. B. If the case will admit of your putting the end of the lever under the resisting body, no fastening will be required; as you will perceive, when a nail is drawn by means of a hammer, which, though bent, is a lever of the first kind; the handle being the longest arm, the point on which it rests, the fulcrum, and the distance from that to the part which holds the nail, the short arm. But let me hear, Caroline, whether you can explain the action of this instrument, which is composed of two levers united in one common fulcrum.

Caroline. A pair of scissors!

Mrs. B. You are surprised; but if you examine their construction, you will discover that it is the power of the lever, that assists us in cutting with scissors.

Caroline. Yes; I now perceive that the point at which the two levers are screwed together, is the fulcrum; the power of the fingers is applied to the handles, and the article to be cut, is the resistance; therefore, the longer the handles, and the shorter the points of the scissors, the more easily you cut with them.

Emily. That I have often observed, for when I cut paste-board or any hard substance, I always make use of that part of the scissors nearest the screw or rivet, and I now understand why it increases the power of cutting; but I confess that I never should have discovered scissors to have been double levers; and pray are not snuffers levers of a similar description?

Mrs. B. Yes, and most kinds of pincers; the great power of which consists in the great relative length of the handles.

Did you ever notice the swingle-tree of a carriage to which the horses are attached when drawing?

Emily. O yes; this is a lever of the first kind, but the fulcrum being in the middle, the horses should draw with equal power, whatever may be their strength.

Mrs. B. That is generally the case, but it is evident that by making one arm longer than the other, it might be adapted to horses of unequal strength.

Caroline. And of what nature are the other two kinds of levers?

Mrs. B. In levers of the second kind, the weight, instead of being at one end, is situated between the power and the fulcrum, ([fig. 6.](#))

[Pg 60]

Caroline. The weight and the fulcrum have here changed places; and what advantage is gained by this kind of lever?

Mrs. B. In moving it, the velocity of the power must necessarily be greater than that of the weight, as it is more distant from the centre of the motion. Have you ever seen your brother move a snow-ball by means of a strong stick, when it became too heavy for him to move without assistance?

Caroline. Oh yes; and this was a lever of the second kind, ([fig. 7.](#)) the end of the stick, which he thrusts under the ball, and which rests on the ground, becomes the fulcrum; the ball is the

weight to be moved, and the power his hands, applied to the other end of the lever. In this instance there is a great difference in the length of the arms of the lever; for the weight is almost close to the fulcrum.

Mrs. B. And the advantage gained is proportional to this difference. The most common example that we have of levers of the second kind, is in the doors of our apartments.

Emily. The hinges represent the fulcrum, our hands the power applied to the other end of the lever; but where is the weight to be moved?

Mrs. B. The door is the weight, which in this example occupies the whole of the space between the power and the fulcrum. Nut crackers are double levers of this kind: the hinge is the fulcrum, the nut the resistance, and the hands the power.

In levers of the third kind ([fig. 8.](#)) the fulcrum is again at one extremity, the weight or resistance at the other, and the power is applied between the fulcrum and the resistance.

Emily. The fulcrum, the weight, or the power, then, each in its turn, occupies some part of the lever between its extremities. But in this third kind of lever, the weight being farther than the power from the centre of motion, the difficulty of raising it seems increased rather than diminished.

Mrs. B. That is very true; a lever of this kind is therefore never used, unless absolutely necessary, as is the case in raising a ladder in order to place it against a wall; the man who raises it cannot place his hands on the upper part of the ladder, the power, therefore, is necessarily placed much nearer to the fulcrum than to the weight.

Caroline. Yes, the hands are the power, the ground the fulcrum, and the upper part of the ladder the weight.

Mrs. B. Nature employs this kind of lever in the structure of the human frame. In lifting a weight with the hand, the lower part of the arm becomes a lever of the third kind; the elbow is the fulcrum, the muscles of the fleshy part of the arm, the power; and as these are nearer to the elbow than to the hand, it is necessary that their power should exceed the weight to be raised.

[Pg 61]

Emily. Is it not surprising that nature should have furnished us with such disadvantageous levers?

Mrs. B. The disadvantage, in respect to power, is more than counterbalanced by the convenience resulting from this structure of the arm; and it is that no doubt which is best adapted to enable it to perform its various functions.

There is one rule which applies to every lever, which is this: In order to produce an equilibrium, the power must bear the same proportion to the weight, as the length of the shorter arm does to that of the longer; as was shown by Emily with the weights of 1 *lb.* and of 3 *lb.* [Fig. 3. plate 4.](#)

We have dwelt so long on the lever, that we must reserve the examination of the other mechanical powers, to our next interview.

Questions

1. (Pg. [54](#)) How many mechanical powers are there, and what are they named?
2. (Pg. [54](#)) What is a mechanical power defined to be?
3. (Pg. [54](#)) What four particulars must be observed?
4. (Pg. [54](#)) Upon what will the velocities depend?
5. (Pg. [55](#)) What is a lever?
6. (Pg. [55](#)) Give a familiar example.
7. (Pg. [55](#)) When and why do the scales balance each other, and where is their centre of gravity? ([fig. 1. plate 4.](#))
8. (Pg. [55](#)) Why would they not balance with unequal weights?
9. (Pg. [55](#)) Were the fulcrum removed from the middle of the beam what would result?
10. (Pg. [55](#)) What do we mean by the arms of a lever?
11. (Pg. [56](#)) How may a pair of scales be false, and yet appear to be true?
12. (Pg. [56](#)) If the fulcrum be removed from the centre of gravity, how may the equilibrium be restored?
13. (Pg. [56](#)) How is this exemplified by [fig. 3. plate 4](#)?
14. (Pg. [56](#)) What proportion must the weights bear to the lengths of the arms?
15. (Pg. [57](#)) On what principle do we weigh with a pair of steelyards, and what will be the difference in the motion of the extremities of such a lever?
16. (Pg. [58](#)) How is this exemplified by [fig. 4. plate 4](#)?
17. (Pg. [58](#)) What line is described by the ends of a lever? [fig. 4. plate 4.](#)
18. (Pg. [58](#)) How many kinds are there; and in the first how is the fulcrum situated?
19. (Pg. [58](#)) When may the fulcrum be so situated that this lever is not a mechanical power, and why?
20. (Pg. [59](#)) What is represented by [fig. 5. plate 4](#)?
21. (Pg. [59](#)) Give a familiar example of the use of a lever of the first kind.
22. (Pg. [59](#)) In what instruments are two such levers combined?
23. (Pg. [59](#)) How may two horses of unequal strength, be advantageously coupled in a carriage?
24. (Pg. [60](#)) Describe a lever of the second kind. ([Fig. 6. plate 4.](#))
25. (Pg. [60](#)) What is represented in [fig. 7. plate 4.](#) and in what proportion does this lever gain power?

26. (Pg. 60) What is said respecting a door?
 27. (Pg. 60) Describe a lever of the third kind.
 28. (Pg. 60) In what instance do we use this?
 29. (Pg. 61) What remarks are made on its employment in the limbs of animals?
 30. (Pg. 61) What are the conditions of equilibrium in every lever?

CONVERSATION V. CONTINUED. ON THE MECHANICAL POWERS.

[Pg 62]

OF THE PULLEY. OF THE WHEEL AND AXLE. OF THE INCLINED PLANE. OF THE WEDGE. OF THE SCREW.

MRS. B.

The pulley is the second mechanical power we are to examine. You both, I suppose, have seen a pulley?

Caroline. Yes, frequently: it is a circular, and flat piece of wood or metal, with a string which runs in a groove round it: by means of which, a weight may be pulled up; thus pulleys are used for drawing up curtains.

Mrs. B. Yes; but in that instance the pulleys are fixed; that is, they retain their places, and merely turn round on their axis; these do not increase the power to raise the weights, as you will perceive by this figure. ([plate 5. fig. 1.](#)) Observe that the fixed pulley is on the same principle as the lever of a pair of scales, in which the fulcrum F being in the centre of gravity, the power P and the weight W, are equally distant from it, and no advantage is gained.

Emily. Certainly; if P represents the power employed to raise the weight W, the power must be greater than the weight in order to move it. But of what use then is a fixed pulley in mechanics?

Mrs. B. Although it does not increase the power, it is frequently useful for altering its direction. A single fixed pulley enables us to draw a curtain up, by pulling the string connected with it downwards; and we should be at a loss to accomplish this simple operation without its assistance.

Caroline. There would certainly be some difficulty in ascending to the head of the curtain, in order to draw it up. Indeed I now recollect having seen workmen raise weights to a considerable height by means of a fixed pulley, which saved them the trouble of going up themselves.

Mrs. B. The next figure represents a pulley which is not fixed; ([fig. 2.](#)) and thus situated, you will perceive that it affords us mechanical assistance.

[Pg 63]

A is a moveable pulley; that is, one which is attached to the weight to be raised, and which consequently moves up or down with it. There is also a fixed pulley D, which is only of use to change the direction of the power P. Now it is evident that the velocity of the power, will be double that of the weight W; for if the rope be pulled at P, until the pulley A ascends with the weight to the fixed pulley D, then both parts of the rope, C and B, must pass over the fixed pulley, and consequently the hand at P, will have descended through a space equal to those two parts; but the weight will have ascended only one half of that distance.

Caroline. That I understand: if P drew the string but one inch, the weight would be raised only half an inch, because it would shorten the strings B and C half an inch each, and consequently the pulley with the weight attached to it, can be raised only half an inch.

Emily. But I do not yet understand the advantage of moveable pulleys; they seem to me to increase rather than diminish the difficulty of raising weights, since you must draw the string double the length that you raise the weight; whilst with a single pulley, or without any pulley, the weight is raised as much as the string is shortened.

Mrs. B. The advantage of a moveable pulley consists in dividing the difficulty; we must, it is true, draw twice the length of the string, but then only half the strength is required that would be necessary to raise the weight without the assistance of a moveable pulley.

Emily. So that the difficulty is overcome in the same manner as it would be, by dividing the weight into two equal parts, and raising them successively.

Mrs. B. Exactly. You must observe, that with a moveable pulley the velocity of the power, is double that of the weight; since the power P ([fig. 2.](#)) moves two inches whilst the weight W moves one inch; therefore the power need not be more than half the weight, to make their momentums equal.

Caroline. Pulleys act then on the same principle as the lever; the deficiency of weight in the power, being compensated by its superior velocity, so as to make their momentums equal.

Mrs. B. You will find, that all gain of power in mechanics is founded on the same principle.

Emily. But may it not be objected to pulleys, that a longer time is required to raise a weight by their aid, than without it? for what you gain in power, you lose in time. [Pg 64]

Mrs. B. That, my dear, is the fundamental law in mechanics: it is the case with the lever, as well as the pulley; and you will find it to be so with all the other mechanical powers.

Caroline. I do not see any advantage in the mechanical powers then, if what we gain by them in one way, is lost in another.

Mrs. B. Since we are not able to increase our natural strength is not any instrument of obvious utility, by means of which we may reduce the resistance or weight of any body, to the level of that strength? This the mechanical powers enable us to accomplish. It is true, as you observe, that it requires a sacrifice of time to attain this end, but you must be sensible how very advantageously it is exchanged for power. If one man by his natural strength could raise one hundred pounds only, it would require five such men to raise five hundred pounds; and if one man performs this by the help of a suitable engine, there is then no actual loss of time; as he does the work of five men, although he is five times as long in its accomplishment.

You can now understand, that the greater the number of moveable pulleys connected by a string, the more easily the weight is raised; as the difficulty is divided amongst the number of strings, or rather of parts into which the string is divided, by the pulleys. Two, or more pulleys thus connected, form what is called a tackle, or system of pulleys. (fig. 3.) You may have seen them suspended from cranes to raise goods into warehouses.

Emily. When there are two moveable pulleys, as in the figure you have shown to us, (fig. 3.) there must also be two fixed pulleys, for the purpose of changing the direction of the string, and then the weight is supported by four strings, and of course, each must bear only one fourth part of the weight.

Mrs. B. You are perfectly correct, and the rule for estimating the power gained by a system of pulleys, is to count the number of strings by which the weight is supported; or, which amounts to the same thing, to multiply the number of moveable pulleys by two.

In shipping, the advantages of both an increase of power, and a change of direction, by means of pulleys, are of essential importance: for the sails are raised up the masts by the sailors on deck, from the change of direction which the pulley effects, and the labour is facilitated by the mechanical power of a combination of pulleys.

PLATE V.

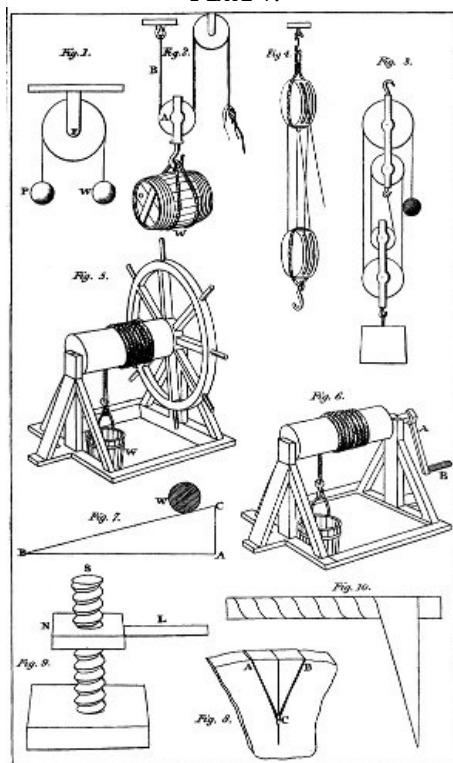

Emily. But the pulleys on ship-board do not appear to me to be united in the manner you have shown us. [Pg 65]

Mrs. B. They are, I believe, generally connected as described in figure 4, both for nautical, and a variety of other purposes; but in whatever manner pulleys are connected by a single string, the mechanical power is the same.

The third mechanical power, is the wheel and axle. Let us suppose (plate 5. fig. 5) the weight W, to be a bucket of water in a well, which we raise by winding round the axle the rope, to which it is attached; if this be done without a wheel to turn the axle, no mechanical assistance is received. The axle without a wheel is as impotent as a single fixed pulley, or a lever, whose fulcrum is in the centre: but add the wheel to the axle, and you will immediately find the bucket is raised with

much less difficulty. The velocity of the circumference of the wheel is as much greater than that of the axle, as it is further from the centre of motion; for the wheel describes a great circle in the same space of time that the axle describes a small one, therefore the power is increased in the same proportion as the circumference of the wheel is greater than that of the axle. If the velocity of the wheel is twelve times greater than that of the axle, a power twelve times less than the weight of the bucket, would balance it; and a small increase would raise it.

Emily. The axle acts the part of the shorter arm of the lever, the wheel that of the longer arm.

Caroline. In raising water, there is commonly, I believe, instead of a wheel attached to the axle, only a crooked handle, which answers the purpose of winding the rope round the axle, and thus raising the bucket.

Mrs. B. In this manner ([fig. 6](#);) now if you observe the dotted circle which the handle describes in winding up the rope, you will perceive that the branch of the handle A, which is united to the axle, represents the spoke of a wheel, and answers the purpose of an entire wheel; the other branch B affords no mechanical aid, merely serving as a handle to turn the wheel.

Wheels are a very essential part of most machines; they are employed in various ways; but, when fixed to the axle, their mechanical power is always the same: that is, as the circumference of the wheel exceeds that of the axle, so much will the energy of the power be increased.

Caroline. Then the larger the wheel, in proportion to the axle, the greater must be its effect?

Mrs. B. Certainly. If you have ever seen any considerable mills or manufactures, you must have admired the immense wheel, the revolution of which puts the whole of the machinery into motion; and though so great an effect is produced by it, a horse or two has sufficient power to turn it; sometimes a stream of water is used for that purpose, but of late years, a steam-engine has been found both the most powerful and the most convenient mode of turning the wheel.

[Pg 66]

Caroline. Do not the vanes of a windmill represent a wheel, Mrs. B.?

Mrs. B. Yes; and in this instance we have the advantage of a gratuitous force, the wind, to turn the wheel. One of the great benefits resulting from the use of machinery is, that it gives us a sort of empire over the powers of nature, and enables us to make them perform the labour which would otherwise fall to the lot of man. When a current of wind, a stream of water, or the expansive force of steam, performs our task, we have only to superintend and regulate their operations.

The fourth mechanical power is the inclined plane; this is generally nothing more than a plank placed in a sloping direction, which is frequently used to facilitate the raising of weights, to a small height, such as the rolling of hogsheads or barrels into a warehouse. It is not difficult to understand, that a weight may much more easily be rolled up a slope than it can be raised the same height perpendicularly. But in this, as well as the other mechanical powers, the facility is purchased by a loss of time ([fig. 7](#);) for the weight, instead of moving directly from A to C, must move from B to C, and as the length of the plane is to its height, so much is the resistance of the weight diminished.

Emily. Yes; for the resistance, instead of being confined to the short line A C, is spread over the long line B C.

Mrs. B. The wedge, which is the next mechanical power, is usually viewed as composed of two inclined planes ([fig. 8](#);) you may have seen wood-cutters use it to cleave wood. The resistance consists in the cohesive attraction of the wood, or any other body which the wedge is employed to separate; the advantage gained by this power is differently estimated by philosophers; but one thing is certain, its power is increased, in proportion to the decrease of its thickness, compared with its length. The wedge is a very powerful instrument, but it is always driven forward by blows from a hammer, or some other body having considerable momentum.

Emily. The wedge, then, is rather a compound than a distinct mechanical power, since it is not propelled by simple pressure, or weight, like the other powers.

[Pg 67]

Mrs. B. It is so. All cutting instruments are constructed upon the principle of the inclined plane, or the wedge: those that have but one edge sloped, like the chisel, may be referred to the inclined plane; whilst the axe, the hatchet, and the knife, (when used to split asunder) are used as wedges.

Caroline. But a knife cuts best when it is drawn across the substance it is to divide. We use it thus in cutting meat, we do not chop it to pieces.

Mrs. B. The reason of this is, that the edge of a knife is really a very fine saw, and therefore acts best when used like that instrument.

The screw, which is the last mechanical power, is more complicated than the others. You will see by this figure, ([fig. 9](#).) that it is composed of two parts, the screw and the nut. The screw S is a cylinder, with a spiral protuberance coiled round it, called the thread; the nut N is perforated to receive the screw, and the inside of the nut has a spiral groove, made to fit the spiral thread of the screw.

Caroline. It is just like this little box, the lid of which screws on the box as you have described; but what is this handle L which projects from the nut?

Mrs. B. It is a lever, which is attached to the nut, without which the screw is never used as a mechanical power. The power of the screw, complicated as it appears, is referable to one of the most simple of the mechanical powers; which of them do you think it is?

Caroline. In appearance, it most resembles the wheel and axle.

Mrs. B. The lever, it is true, has the effect of a wheel, as it is the means by which you turn the nut, or sometimes the screw, round; but the lever is not considered as composing a part of the screw, though it is true, that it is necessarily attached to it.

Emily. The spiral thread of the screw resembles, I think, an inclined plane: it is a sort of slope, by means of which the nut ascends more easily than it would do if raised perpendicularly; and it serves to support it when at rest.

Mrs. B. Very well: if you cut a slip of paper in the form of an inclined plane, and wind it round your pencil, which will represent the cylinder, you will find that it makes a spiral line, corresponding to the spiral protuberance of the screw. (Fig. 10.)

[Pg 68]

Emily. Very true; the nut then ascends an inclined plane, but ascends it in a spiral, instead of a straight line: the closer the threads of the screw, the more easy the ascent: it is like having shallow, instead of steep steps to ascend.

Mrs. B. Yes; excepting that the nut takes no steps, as it gradually winds up or down; then observe, that the closer the threads of the screw, the less is its ascent in turning round, and the greater is its power; so that we return to the old principle,—what is saved in power is lost in time.

Emily. Cannot the power of the screw be increased also, by lengthening the lever attached to the nut?

Mrs. B. Certainly. The screw, with the addition of the lever, forms a very powerful machine, employed either for compression or to raise heavy weights. It is used by book-binders, to press the leaves of books together; it is used also in cider and wine presses, in coining, and for a variety of other purposes.

Emily. Pray, Mrs. B., by what rule do you estimate the power of the screw?

Mrs. B. By measuring the circumference of the circle, which the end of the lever would form in one whole revolution, and comparing this with the distance from the centre of one thread of the screw, to that of its next contiguous turn; for whilst the lever travels that whole distance, the screw rises or falls only through the distance from one coil to another.

Caroline. I think that I have sometimes seen the lever attached to the screw, and not to the nut, as it is represented in the figure.

Mrs. B. This is frequently done, but it does not in any degree affect the power of the instrument.

All machines are composed of one or more of these six mechanical powers we have examined; I have but one more remark to make to you relative to them, which is, that friction in a considerable degree diminishes their force: allowance must therefore always be made for it, in the construction of machinery.

Caroline. By friction, do you mean one part of the machine rubbing against another part contiguous to it?

Mrs. B. Yes; friction is the resistance which bodies meet with in rubbing against each other; there is no such thing as perfect smoothness or evenness in nature; polished metals, though they wear that appearance more than most other bodies, are far from really possessing it; and their inequalities may frequently be perceived through a good magnifying glass. When, therefore, the surfaces of the two bodies come in contact, the prominent parts of the one, will often fall into the hollow parts of the other, and occasion more or less resistance to motion.

[Pg 69]

Caroline. But if a machine is made of polished metal, as a watch for instance, the friction must be very trifling?

Mrs. B. In proportion as the surfaces of bodies are well polished, the friction is doubtless diminished; but it is always considerable, and it is usually computed to destroy one-third of the power of a machine. Oil or grease is used to lessen friction: it acts as a polish, by filling up the cavities of the rubbing surfaces, and thus making them slide more easily over each other.

Caroline. Is it for this reason that wheels are greased, and the locks and hinges of doors oiled?

Mrs. B. Yes; in these instances the contact of the rubbing surfaces is so close, and they are so constantly in use, that they require to be frequently oiled, or a considerable degree of friction is produced.

There are two kinds of friction; the first is occasioned by the rubbing of the surfaces of bodies against each other, the second, by the rolling of a circular body; as that of a carriage wheel upon the ground: the friction resulting from the first is much the most considerable, for great force is required to enable the sliding body to overcome the resistance which the asperities of the surfaces in contact oppose to its motion, and it must be either lifted over, or break through them; whilst, in the second kind of friction, the rough parts roll over each other with comparative facility; hence it is, that wheels are often used for the sole purpose of diminishing the resistance

from friction.

Emily. This is one of the advantages of carriage wheels, is it not?

Mrs. B. Yes; and the larger the circumference of the wheel the more readily it can overcome any considerable obstacles, such as stones, or inequalities in the road. When, in descending a steep hill, we fasten one of the wheels, we decrease the velocity of the carriage, by increasing the friction.

Caroline. That is to say, by converting the rolling friction into the rubbing friction. And when you had casters put to the legs of the table, in order to move it more easily, you changed the rubbing into the rolling friction.

Mrs. B. There is another circumstance which we have already noticed, as diminishing the motion of bodies, and which greatly affects the power of machines. This is the resistance of the medium, in which a machine is worked. All fluids, whether elastic like air, or non-elastic like water and other liquids, are called mediums; and their resistance is proportioned to their density; for the more matter a body contains, the greater the resistance it will oppose to the motion of another body striking against it.

[Pg 70]

Emily. It would then be much more difficult to work a machine under water than in the air?

Mrs. B. Certainly, if a machine could be worked in *vacuo*, and without friction, it would not be impeded, but this is unattainable; a considerable reduction of power must therefore be allowed for, from friction and the resistance of the medium.

We shall here conclude our observations on the mechanical powers. At our next meeting I shall endeavour to give you an explanation of the motion of the heavenly bodies.

Questions

31. (Pg. 62) Describe a pulley, and its use.
32. (Pg. 62) What is meant by a fixed pulley and why is not power gained by its employment? (fig. 1. plate 5.)
33. (Pg. 62) Of what use is the fixed pulley?
34. (Pg. 63) How is the power gained by a moveable pulley, explained by means of fig. 2. plate 5?
35. (Pg. 63) What proportion must the power bear to the weight in fig. 2, that their momentums may be equal?
36. (Pg. 64) What is a fundamental law as respects power and time?
37. (Pg. 64) If to gain power we must lose time, what advantage do we derive from the mechanical powers?
38. (Pg. 64) What name is given to two or more pulleys connected by one string?
39. (Pg. 64) How do we estimate the power gained by a system of pulleys?
40. (Pg. 65) What is represented by fig. 5. plate 5?
41. (Pg. 65) How does the wheel operate in increasing power?
42. (Pg. 65) How is this compared with the lever?
43. (Pg. 65) How does a handle fixed to an axle, represent a wheel, fig. 6?
44. (Pg. 65) How could we increase the power in this instrument?
45. (Pg. 66) What other forces besides the power of men, do we employ to move machines?
46. (Pg. 66) What will serve as an example of an inclined plane?
47. (Pg. 66) In what proportion does it gain power? (fig. 7.)
48. (Pg. 66) To what is the wedge compared? (fig. 8.)
49. (Pg. 66) How does its power increase?
50. (Pg. 67) Why is it rather a compound than a simple power?
51. (Pg. 67) What common instruments act upon the principle of the inclined plane, or the wedge?
52. (Pg. 67) Why does a knife cut best when drawn across?
53. (Pg. 67) The screw has two essential parts; what are they?
54. (Pg. 67) What other instrument is used to turn the screw?
55. (Pg. 67) How can you compare the screw with an inclined plane? Fig. 10.
56. (Pg. 68) By what two means may the power of the screw be increased?
57. (Pg. 68) How do we estimate the power gained by the screw?
58. (Pg. 68) Is the lever always attached to the nut, as in the figure?
59. (Pg. 68) What is said respecting the composition of all machines, and for what must allowance always be made in estimating their power?
60. (Pg. 69) What is meant by friction, and what causes it?
61. (Pg. 69) How may friction be diminished?
62. (Pg. 69) Friction is of two kinds, what are they?
63. (Pg. 69) For what purpose are wheels often used?
64. (Pg. 69) When is the friction of a carriage wheel changed from the rolling to the rubbing friction?
65. (Pg. 70) What is a medium, and in what proportion does it diminish motion?
66. (Pg. 70) Under what circumstances must a body be placed, in order to move without impediment?

OF THE EARTH'S ANNUAL MOTION. OF THE PLANETS AND THEIR MOTION. OF THE DIURNAL MOTION OF THE EARTH AND PLANETS.

CAROLINE.

I am come to you to-day quite elated with the spirit of opposition, Mrs. B.; for I have discovered such a powerful objection to your theory of attraction, that I doubt whether even your conjuror Newton, with his magic wand of gravitation, will be able to dispel it.

Mrs. B. Well, my dear, pray what is this weighty objection?

PLATE VI.

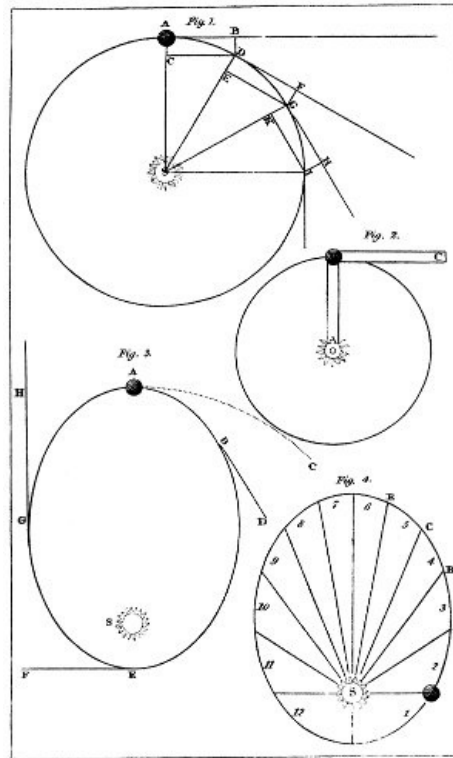

Caroline. You say that the earth revolves in its orbit round the sun once in a year, and that bodies attract in proportion to the quantity of matter they contain; now we all know the sun to be much larger than the earth: why, therefore does it not draw the earth into itself; you will not, I suppose, pretend to say that we are falling towards the sun?

[Pg 71]

Emily. However plausible your objection appears, Caroline, I think you place too much reliance upon it: when any one has given such convincing proofs of sagacity and wisdom as Sir Isaac Newton, when we find that his opinions are universally received and adopted, is it to be expected that any objection we can advance should overturn them?

Caroline. Yet I confess that I am not inclined to yield implicit faith even to opinions of the great Newton: for what purpose are we endowed with reason, if we are denied the privilege of making use of it, by judging for ourselves.

Mrs. B. It is reason itself which teaches us, that when we, novices in science, start objections to theories established by men of knowledge and wisdom, we should be diffident rather of our own than of their opinion. I am far from wishing to lay the least restraint on your questions; you cannot be better convinced of the truth of a system, than by finding that it resists all your attacks, but I would advise you not to advance your objections with so much confidence, in order that the discovery of their fallacy may be attended with less mortification. In answer to that you have just proposed, I can only say, that the earth really is attracted by the sun.

Caroline. Take care, at least, that we are not consumed by him, Mrs. B.

Mrs. B. We are in no danger; but Newton, our magician, as you are pleased to call him, cannot extricate himself from this difficulty without the aid of some cabalistical figures, which I must draw for him.

Let us suppose the earth, at its creation, to have been projected forwards into universal space: we know that if no obstacle impeded its course it would proceed in the same direction, and with a uniform velocity for ever. In [fig. 1. plate 6](#), A represents the earth, and S the sun. We shall suppose the earth to be arrived at the point in which it is represented in the figure, having a velocity which would carry it on to B in the space of one month; whilst the sun's attraction would bring it to C in the same space of time. Observe that the two forces of projection and attraction do not act in opposition, but perpendicularly, or at a right angle to each other. Can you tell me now, how the earth will move?

Emily. I recollect your teaching us that a body acted upon by two forces perpendicular to each

[Pg 72]

other, would move in the diagonal of a parallelogram; if, therefore, I complete the parallelogram, by drawing the lines C D, B D, the earth will move in the diagonal A D.

Mrs. B. A ball struck by two forces acting perpendicularly to each other, it is true, moves in the diagonal of a parallelogram; but you must observe that the force of attraction is continually acting upon our terrestrial ball, and producing an incessant deviation from its course in a right line, which converts it into that of a curve-line; every point of which may be considered as constituting the diagonal of an infinitely small parallelogram.

Let us retain the earth a moment at the point D, and consider how it will be affected by the combined action of the two forces in its new situation. It still retains its tendency to fly off in a straight line; but a straight line would now carry it away to F, whilst the sun would attract it in the direction D S; how then will it proceed?

Emily. It will go on in a curve-line, in a direction between that of the two forces.

Mrs. B. In order to know exactly what course the earth will follow, draw another parallelogram similar to the first, in which the line D F describes the force of projection, and the line D S that of attraction; and you will find that the earth will proceed in the curve-line D G.

Caroline. You must now allow me to draw a parallelogram, Mrs. B. Let me consider in what direction will the force of projection now impel the earth.

Mrs. B. First draw a line from the earth to the sun representing the force of attraction; then describe the force of projection at a right angle to it.

Caroline. The earth will then move in the curve G I, of the parallelogram G H I K.

Mrs. B. You recollect that a body acted upon by two forces, moves through a diagonal, in the same time that it would have moved through one of the sides of the parallelogram, were it acted upon by one force only. The earth has passed through the diagonals of these three parallelograms, in the space of three months, and has performed one quarter of a circle; and on the same principle it will go on till it has completed the whole of the circle. It will then recommence a course, which it has pursued ever since it first issued from the hand of its Creator, and which there is every reason to suppose it will continue to follow, as long as it remains in existence.

[Pg 73]

Emily. What a grand and beautiful effect resulting from so simple a cause!

Caroline. It affords an example, on a magnificent scale, of the curvilinear motion, which you taught us in mechanics. The attraction of the sun is the centripetal force, which confines the earth to a centre; and the impulse of projection, the centrifugal force, which impels the earth to quit the sun, and fly off in a tangent.

Mrs. B. Exactly so. A simple mode of illustrating the effect of these combined forces on the earth, is to cut a slip of card in the form of a carpenter's square, as A, B, C; ([fig. 2. plate 6.](#)) the point B will be a right angle, the sides of the square being perpendicular to each other; after having done this you are to describe a small circle at the angular point B, representing the earth, and to fasten the extremity of one of the legs of the square to a fixed point A, which we shall consider as the sun. Thus situated, the two sides of the square will represent both the centrifugal and centripetal forces; A B, representing the centripetal, and B C, the centrifugal force; if you now draw it round the fixed point, you will see how the direction of the centrifugal force varies, constantly forming a tangent to the circle in which the earth moves, as it is constantly at a right angle with the centripetal force.

Emily. The earth then, gravitates towards the sun, without the slightest danger either of approaching nearer, or receding further from it. How admirably this is contrived! If the two forces which produce this curved motion, had not been so accurately adjusted, one would ultimately have prevailed over the other, and we should either have approached so near the sun as to have been burnt, or have receded so far from it as to have been frozen.

Mrs. B. What will you say, my dear, when I tell you, that these two forces are not, in fact, so proportioned as to produce circular motion in the earth? We actually revolve round the sun in an elliptical or oval orbit, the sun being situated in one of the foci or centres of the oval, so that the sun is at some periods much nearer to the earth, than at others.

Caroline. You must explain to us, at least, in what manner we avoid the threatened destruction.

Mrs. B. Let us suppose that when the earth is at A, ([fig. 3.](#)) its projectile force should not have given it a velocity sufficient to counterbalance that of gravity, so as to enable these powers conjointly to carry it round the sun in a circle; the earth, instead of describing the line A C, as in the former figure, will approach nearer the sun in the line A B.

[Pg 74]

Caroline. Under these circumstances, I see not what is to prevent our approaching nearer and nearer the sun, till we fall into it: for its attraction increases as we advance towards it, and produces an accelerated velocity in the earth, which increases the danger.

Mrs. B. There is another seeming danger, of which you are not aware. Observe, that as the earth approaches the sun, the direction of its projectile force is no longer perpendicular to that of its attraction, but inclines more nearly to it. When the earth reaches that part of its orbit at B, the force of projection would carry it to D, which brings it nearer the sun instead of bearing it away

from it.

Emily. If, then, we are driven by one power, and drawn by the other to this centre of destruction, how is it possible for us to escape?

Mrs. B. A little patience, and you will find that we are not without resource. The earth continues approaching the sun with a uniformly increasing accelerated motion, till it reaches the point E; in what direction will the projectile force now impel it?

Emily. In the direction E F. Here then the two forces act perpendicularly to each other, the lines representing them forming a right angle, and the earth is situated just as it was in the preceding figure; therefore, from this point, it should revolve round the sun in a circle.

Mrs. B. No, all the circumstances do not agree. In motion round a centre, you recollect that the centrifugal force increases with the velocity of the body, or in other words, the quicker it moves the stronger is its tendency to fly off in a right line. When the earth, therefore, arrives at E, its accelerated motion will have so far increased its velocity, and consequently its centrifugal force, that the latter will prevail over the force of attraction, and force the earth away from the sun till it reaches G.

Caroline. It is thus then that we escape from the dangerous vicinity of the sun; and in proportion as we recede from it, the force of its attraction, and, consequently, the velocity of the earth's motion, are diminished.

Mrs. B. Yes. From G the direction of projection is towards H, that of attraction towards S, and the earth proceeds between them with a uniformly retarded motion, till it has completed its revolution. Thus you see that the earth travels round the sun, not in a circle, but an ellipsis, of which the sun occupies one of the *foci*; and that in its course, the earth alternately approaches and recedes from it, without any danger of being either swallowed up, or being entirely carried away from it.

[Pg 75]

Caroline. And I observe, that what I apprehended to be a dangerous irregularity, is the means by which the most perfect order and harmony are produced.

Emily. The earth travels then at a very unequal rate, its velocity being accelerated as it approaches the sun, and retarded as it recedes from it.

Mrs. B. It is mathematically demonstrable, that, in moving round a point towards which it is attracted, a body passes over equal areas, in equal times. The whole of the space contained within the earth's orbit, is in [fig. 4](#), divided into a number of areas or surfaces; 1, 2, 3, 4, &c. all of which are of equal dimensions, though of very different forms; some of them, you see, are long and narrow, others broad and short: but they each of them contain an equal quantity of space. An imaginary line drawn from the centre of the earth to that of the sun, and keeping pace with the earth in its revolution, passes over equal areas in equal times; that is to say, if it is a month going from A to B, it will be a month going from B to C, and another from C to E, and so on; and the areas A B S, B C S, C E S, will be equal to each other, although the lines A B, B C, C E, are unequal.

Caroline. What long journeys the earth has to perform in the course of a month, in one part of her orbit, and how short they are in the other part!

Mrs. B. The inequality is not so considerable as appears in this figure; for the earth's orbit is not so eccentric as it is there described; and in reality, differs but little from a circle: that part of the earth's orbit nearest the sun is called its *perihelion*, that part most distant from the sun, its *aphelion*; and the earth is above three millions of miles nearer the sun at its perihelion than at its aphelion.

Emily. I think I can trace a consequence from these different situations of the earth; are not they the cause of summer and winter?

Mrs. B. On the contrary, during the height of summer, the earth is in that part of its orbit which is most distant from the sun, and it is during the severity of winter, that it approaches nearest to it.

[Pg 76]

Emily. That is very extraordinary; and how then do you account for the heat being greatest, when we are most distant from the sun?

Mrs. B. The difference of the earth's distance from the sun in summer and winter, when compared with its total distance from the sun, is but inconsiderable. The earth, it is true, is above three millions of miles nearer the sun in winter than in summer; but that distance, however great it at first appears, sinks into insignificance in comparison with 95 millions of miles, which is our mean distance from the sun. The change of temperature, arising from this difference, would scarcely be sensible, even were it not completely overpowered by other causes which produce the variations of the seasons; but these I shall defer explaining, till we have made some further observations on the heavenly bodies.

Caroline. And should not the sun appear smaller in summer, when it is so much further from us?

Mrs. B. It actually does, when accurately measured; but the apparent difference in size, is, I believe, not perceptible to the naked eye.

Emily. Then, since the earth moves with the greatest velocity in that part of its orbit in which it is nearest the sun, it must have completed its journey through that half of its orbit, in a shorter time than through the other?

Mrs. B. Yes, it is about seven days longer performing the summer-half of its orbit, than the winter-half; and the summers are consequently seven days longer in the northern, than they are in the southern hemisphere.

The revolution of all the planets round the sun, is the result of the same causes, and is performed in the same manner, as that of the earth.

Caroline. Pray what are the planets?

Mrs. B. They are those celestial bodies, which revolve like our earth, about the sun; they are supposed to resemble the earth also in many other respects; and we are led by analogy, to suppose them to be inhabited worlds.

Caroline. I have heard so, but do you not think such an opinion too great a stretch of the imagination? [Pg 77]

Mrs. B. Some of the planets are proved to be larger than the earth; it is only their immense distance from us, which renders their apparent dimensions so small. Now, if we consider them as enormous globes, instead of small twinkling spots, we shall be led to suppose that the Almighty would not have created them merely for the purpose of giving us a little light in the night, as it was formerly imagined; and we should find it more consistent with our ideas of the Divine wisdom and beneficence, to suppose that these celestial bodies should be created for the habitation of beings, who are, like us, blessed by his providence. Both in a moral, as well as a physical point of view, it appears to me more rational to consider the planets as worlds revolving round the sun; and the fixed stars as other suns, each of them attended by their respective system of planets, to which they impart their influence. We have brought our telescopes to such a degree of perfection, that from the appearances which the moon exhibits when seen through them, we have very good reason to conclude that it is a habitable globe: for though it is true that we cannot discern its towns and people, we can plainly perceive its mountains and valleys: and some astronomers have gone so far as to imagine that they discovered volcanos.

Emily. If the fixed stars are suns, with planets revolving round them, why should we not see those planets as well as their suns?

Mrs. B. In the first place, we conclude that the planets of other systems (like those of our own) are much smaller than the suns which give them light; therefore at a distance so great as to make the suns appear like fixed stars, the planets would be quite invisible. Secondly, the light of the planets being only reflected light, is much more feeble than that of the fixed stars. There is exactly the same difference as between the light of the sun and that of the moon; the first being a fixed star, the second a planet.

Emily. But the planets appear to us as bright as the fixed stars, and these you tell us are suns like our own; why then do we not see them by daylight, when they must be just as luminous as they are in the night?

Mrs. B. Both are invisible from the same cause: their light is so faint, compared to that of the sun, that it is entirely effaced by it: the light emitted by the fixed stars may probably be as great as that of our sun, at an equal distance; but they being so much more remote, it is diffused over a greater space, and is in consequence proportionally lessened. [Pg 78]

Caroline. True; I can see much better by the light of a candle that is near me, than by that of one at a great distance. But I do not understand what makes the planets shine?

Mrs. B. What is that which makes the gilt buttons on your brothers coat shine?

Caroline. The sun. But if it was the sun which made the planets shine, we should see them in the day-time, when the sun shone upon them; or if the faintness of their light prevented our seeing them in the day, we should not see them at all, for the sun cannot shine upon them in the night.

Mrs. B. There you are in error. But in order to explain this to you, I must first make you acquainted with the various motions of the planets.

You know, that according to the laws of attraction, the planets belonging to our system all gravitate towards the sun; and that this force, combined with that of projection, will occasion their revolution round the sun, in orbits more or less elliptical, according to the proportion which these two forces bear to each other.

But the planets have also another motion: they revolve upon their axis. The axis of a planet is an imaginary line which passes through its centre, and on which it turns; and it is this motion which produces day and night. It is day on that side of the planet which faces the sun; and on the opposite side, which remains in darkness, it is night. Our earth, which we consider as a planet, is 24 hours in performing one revolution on its axis; in that period of time, therefore, we have a day and a night; hence this revolution is called the earth's diurnal or daily motion; and it is this revolution of the earth from west to east which produces an apparent motion of the sun, moon and stars, in a contrary direction.

Let us now suppose ourselves to be beings independent of any planet, travelling in the skies, and

looking upon the earth from a point as distant from it as from other planets.

Caroline. It would not be flattering to us, its inhabitants, to see it make so insignificant an appearance.

Mrs. B. To those accustomed to contemplate it in this light, it could never appear more glorious. We are taught by science to distrust appearances; and instead of considering the fixed stars and planets as little points, we look upon them either as brilliant suns, or habitable worlds; and we consider the whole together as forming one vast and magnificent system, worthy of the Divine hand by which it was created.

[Pg 79]

Emily. I can scarcely conceive the idea of this immensity of creation; it seems too sublime for our imagination;—and to think that the goodness of Providence extends over millions of worlds throughout a boundless universe—Ah! Mrs. B., it is we only who become trifling and insignificant beings in so magnificent a creation!

Mrs. B. This idea should teach us humility, but without producing despondency. The same Almighty hand which guides these countless worlds in their undeviating course, conducts with equal perfection, the blood as it circulates through the veins of a fly, and opens the eye of the insect to behold His wonders. Notwithstanding this immense scale of creation, therefore, we need not fear that we shall be disregarded or forgotten.

But to return to our station in the skies. We were, if you recollect, viewing the earth at a great distance, in appearance a little star, one side illumined by the sun, the other in obscurity. But would you believe it, Caroline, many of the inhabitants of this little star imagine that when that part which they inhabit is turned from the sun, darkness prevails throughout the universe, merely because it is night with them; whilst, in reality, the sun never ceases to shine upon every planet. When, therefore, these little ignorant beings look around them during their night, and behold all the stars shining, they cannot imagine why the planets, which are dark bodies, should shine; concluding, that since the sun does not illumine themselves, the whole universe must be in darkness.

Caroline. I confess that I was one of these ignorant people; but I am now very sensible of the absurdity of such an idea. To the inhabitants of the other planets, then, we must appear as a little star?

Mrs. B. Yes, to those which revolve round our sun; for since those which may belong to other systems, (and whose existence is only hypothetical) are invisible to us, it is probable that we also are invisible to them.

Emily. But they may see our sun as we do theirs, in appearance a fixed star?

Mrs. B. No doubt; if the beings who inhabit those planets are endowed with senses similar to ours. By the same rule we must appear as a moon to the inhabitants of our moon; but on a larger scale, as the surface of the earth is about thirteen times as large as that of the moon.

Emily. The moon, Mrs. B., appears to move in a different direction, and in a different manner from the stars?

[Pg 80]

Mrs. B. I shall defer the explanation of the motion of the moon till our next interview, as it would prolong our present lesson too much.

Questions

1. (Pg. 71) What revolution does the earth perform in a year?
2. (Pg. 71) Had the earth received a projectile force only, at the time of its creation, how would it have moved?
3. (Pg. 72) What do the lines A B, and A C, represent in [fig. 1. plate 6](#)?
4. (Pg. 72) What have you been taught respecting a body acted upon by two forces at right angles with each other?
5. (Pg. 72) How does the force of gravity change the diagonal into a curved line?
6. (Pg. 72) Describe the operation of the forces of projection and of gravity as illustrated by the parallelograms in the figure?
7. (Pg. 72) What is the law respecting the time required for motion in the diagonal?
8. (Pg. 72) What portion of a year is represented by the three diagonals in the figure?
9. (Pg. 73) How will what you have learned respecting motion in a curve, apply to the earth's motion?
10. (Pg. 73) In what form are you directed to cut a piece of card to aid in illustrating the two forces acting upon the earth?
11. (Pg. 73) How must you apply it to this purpose? ([fig. 2. plate 6.](#))
12. (Pg. 73) If these two forces did not exactly balance each other, what would result?
13. (Pg. 73) Does the earth revolve in a circular orbit?
14. (Pg. 73) What results from its motion in an ellipsis?
15. (Pg. 74) What is represented by the lines A C, A B, in [fig. 3. plate 6](#)?
16. (Pg. 74) Were the projectile force to carry the earth from B to D, ([fig. 3.](#)) what would result?
17. (Pg. 74) When it has arrived at E, what angle will be formed by the lines representing the two forces?
18. (Pg. 74) What effect will the accelerated motion then produce?
19. (Pg. 75) What is the form of the earth's orbit, and what circumstances produce this form?
20. (Pg. 75) What is the consequence as regards the regularity of the earth's motion?

21. (Pg. 75) What law governs as regards the spaces passed over, and how is this explained by [fig. 4.](#) [plate 6](#)?
22. (Pg. 75) What is meant by *perihelion*, and by *aphelion*?
23. (Pg. 75) What is the difference of the distance of the earth from the sun, in these two points?
24. (Pg. 76) At what season of the year is it nearest to, and at what furthest from the sun?
25. (Pg. 76) What is the mean distance of the earth from the sun?
26. (Pg. 76) Why is but little effect produced, as regards temperature, by the change of distance?
27. (Pg. 76) Has it any influence on the sun's apparent size?
28. (Pg. 76) Are the summer and winter, half years, of the same length; what is their difference, and what is the cause?
29. (Pg. 76) What are the planets?
30. (Pg. 77) What circumstances render it probable that they are habitable globes?
31. (Pg. 77) What is believed respecting the fixed stars?
32. (Pg. 77) What discoveries have been made in the moon?
33. (Pg. 77) What prevents our seeing the planets, if there are any, which revolve round the fixed stars?
34. (Pg. 77) What prevents our seeing the stars and planets in the day-time?
35. (Pg. 78) What other motions have the earth and planets, besides that in their orbits?
36. (Pg. 78) What is the imaginary line called, round which they revolve?
37. (Pg. 78) How does this occasion night and day?
38. (Pg. 78) In what direction does the earth turn upon its axis, and what apparent motion of the sun, moon, and stars is thereby produced?
39. (Pg. 79) What must be the appearance of the earth to an inhabitant of one of the planets?
40. (Pg. 79) What the appearance of the sun to the inhabitants of planets in other systems?
41. (Pg. 79) What the appearance of the earth to an inhabitant of the moon?

CONVERSATION VII. OF THE PLANETS.

OF THE SATELLITES OR MOONS. GRAVITY DIMINISHES AS THE SQUARE OF THE DISTANCE. OF THE SOLAR SYSTEM. OF COMETS. CONSTELLATIONS, SIGNS OF THE ZODIAC. OF COPERNICUS, NEWTON, &c.

MRS. B.

The planets are distinguished into primary and secondary. Those which revolve immediately about the sun are called primary. Many of these are attended in their course by smaller planets, which, revolve round them: these are called secondary planets, satellites, or moons. Such is our moon which accompanies the earth, and is carried with it round the sun.

Emily. How then can you reconcile the motion of the secondary planets to the laws of gravitation; for the sun is much larger than any of the primary planets; and is not the power of gravity proportional to the quantity of matter?

Caroline. Perhaps the sun, though much larger, may be less dense than the planets. Fire you know, is very light, and it may contain but little matter, though of great magnitude.

Mrs. B. We do not know of what kind of matter the sun is made; but we may be certain, that since it is the general centre of attraction of our system of planets, it must be the body which contains the greatest quantity of matter in that system.

You must recollect, that the force of attraction is not only proportional to the quantity of matter, but to the degree of proximity of the attractive body: this power is weakened by being diffused, and diminishes as the distance increases.

[Pg 81]

Emily. Then if a planet was to lose one-half of its quantity of matter, it would lose one half of its attractive power; and the same effect would be produced by removing it to twice its former distance from the sun; that I understand.

Mrs. B. Not so perfectly as you imagine. You are correct as respects the diminution in size, because the attractive force is in the same proportion as the quantity of matter; but were you to remove a planet to double its former distance, it would retain but one-fourth part of its gravitating force; for attraction decreases not in proportion to the simple increase of the distance, but as the squares of the distances increase.

Caroline. I do not exactly comprehend what is meant by the squares, in this case, although I know very well what is in general intended by a square.

Mrs. B. By the square of a number we mean the product of a number, multiplied by itself; thus two, multiplied by two, is four, which is therefore the square of two; in like manner the square of three, is nine, because three multiplied by three, gives that product.

Emily. Then if one planet is three times more distant from the sun than another, it will be attracted with but one-ninth part of the force; and if at four times the distance, with but one-sixteenth, sixteen being the square of four?

Mrs. B. You are correct; the rule is, that *the attractive force is in the inverse proportion of the square of the distance.* And it is easily demonstrated by the mathematics, that the same is the case with every power that emanates from a centre; as for example, the light from the sun, or from any other luminous body, decreases in its intensity at the same rate.

Caroline. Then the more distant planets, move much slower in their orbits; for their projectile force must be proportioned to that of attraction? But I do not see how this accounts for the motion of the secondary, round the primary planets, in preference to moving round the sun?

Emily. Is it not because the vicinity of the primary planets, renders their attraction stronger than that of the sun?

Mrs. B. Exactly so. But since the attraction between bodies is mutual, the primary planets are also attracted by the satellites which revolve round them. The moon attracts the earth, as well as the earth the moon; but as the latter is the smaller body, her attraction is proportionally less; therefore, neither the earth revolves round the moon, nor the moon round the earth; but they both revolve round a point, which is their common centre of gravity, and which is as much nearer to the earth than to the moon, as the gravity of the former exceeds that of the latter.

[Pg 82]

Emily. Yes, I recollect your saying, that if two bodies were fastened together by a wire or bar, their common centre of gravity would be in the middle of the bar, provided the bodies were of equal weight; and if they differed in weight, it would be nearer the larger body. If then, the earth and moon had no projectile force which prevented their mutual attraction from bringing them together, they would meet at their common centre of gravity.

Caroline. The earth then has a great variety of motion, it revolves round the sun, round its own axis, and round the point towards which the moon attracts it.

Mrs. B. Just so; and this is the case with every planet which is attended by satellites. The complicated effect of this variety of motions, produces certain irregularities, which, however, it is not necessary to notice at present, excepting to observe that they eventually correct each other, so that no permanent derangement exists.

The planets act on the sun, in the same manner as they are themselves acted on by their satellites; for attraction, you must remember, is always mutual; but the gravity of the planets (even when taken collectively) is so trifling compared with that of the sun, that were they all placed on the same side of that luminary, they would not cause him to move so much as one-half of his diameter towards them, and the common centre of gravity, would still remain within the body of the sun. The planets do not, therefore, revolve round the centre of the sun, but round a point at a small distance from its centre, about which the sun also revolves.

Emily. I thought the sun had no motion?

Mrs. B. You were mistaken; for besides that round the common centre of gravity, which I have just mentioned, which is indeed very inconsiderable, he revolves on his axis in about 25 days; this motion is ascertained by observing certain spots which disappear, and reappear regularly at stated times.

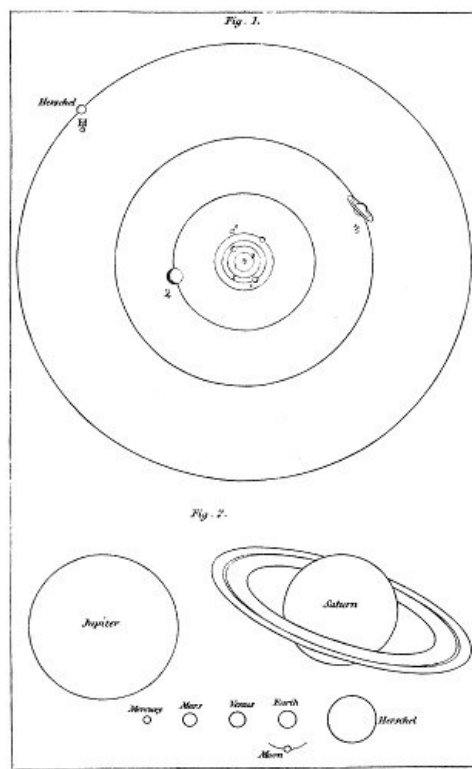

Caroline. A planet has frequently been pointed out to me in the heavens; but I could not perceive that its motion differed from that of the fixed stars, which only appear to move. [Pg 83]

Mrs. B. The great distance of the planets, renders their apparent motion so slow, that the eye is not sensible of their progress in their orbits, unless we watch them for some considerable length of time: but if you notice the nearness of a planet to any particular fixed star, you may in a few nights perceive that it has changed its distance from it, whilst the stars themselves always retain their relative situations. The most accurate idea I can give you of the situation and motion of the planets in their orbits, will be by the examination of this diagram, (plate 7. fig. 1.) representing the solar system, in which you will find every planet, with its orbit delineated.

Emily. But the orbits here are all circular, and you said that they were elliptical. The planets appear too, to be moving round the centre of the sun; whilst you told us that they moved round a point at a little distance from thence.

Mrs. B. The orbits of the planets are so nearly circular, and the common centre of gravity of the solar system, so near the centre of the sun, that these deviations are too small to be represented. The dimensions of the planets, in their proportion to each other, you will find delineated in fig. 2.

Mercury is the planet nearest the sun; his orbit is consequently contained within ours; his vicinity to the sun, prevents our frequently seeing him, so that very accurate observations cannot be made upon Mercury. He performs his revolution round the sun in about 87 days, which is consequently the length of his year. The time of his rotation on his axis is not known; his distance from the sun is computed to be 37 millions of miles, and his diameter 3180 miles. The heat of this planet is supposed to be so great, that water cannot exist there but in a state of vapour, and that even quicksilver would be made to boil.

Caroline. Oh, what a dreadful climate!

Mrs. B. Though we could not live there, it may be perfectly adapted to other beings, destined to inhabit it; or he who created it may have so modified the heat, by provisions of which we are ignorant, as to make it habitable even by ourselves.

Venus, the next in the order of planets, is 68 millions of miles from the sun: she revolves about her axis in 23 hours and 21 minutes, and goes round the sun in 244 days, 17 hours. The orbit of Venus is also within ours; during nearly one-half of her course in it, we see her before sun-rise, and she is then called the morning star; in the other part of her orbit she rises later than the sun. [Pg 84]

Caroline. In that case we cannot see her, for she must rise in the day time?

Mrs. B. True; but when she rises later than the sun, she also sets later; so that we perceive her approaching the horizon after sun-set: she is then called Hesperus, or the evening star. Do you recollect those beautiful lines of Milton?

Now came still evening on, and twilight gray
 Had in her sober livery all things clad;
 Silence accompanied; for beast and bird,
 They to their grassy couch, these to their nests
 Were slunk, all but the wakeful nightingale;
 She all night long her amorous descant sung;
 Silence was pleas'd; now glowed the firmament

With living sapphires. Hesperus that led
The starry host, rode brightest, till the moon
Rising in clouded majesty, at length
Apparent queen unveil'd her peerless light,
And o'er the dark her silver mantle threw.

The planet next to Venus is the Earth, of which we shall soon speak at full length. At present I shall only observe that we are 95 millions of miles distant from the sun, that we perform our annual revolution in 365 days 5 hours and 49 minutes; and are attended in our course by a single moon.

Next follows Mars. He can never come between us and the sun, like Mercury and Venus; his motion is, however, very perceptible, as he may be traced to different situations in the heavens; his distance from the sun is 144 millions of miles; he turns round his axis in 24 hours and 39 minutes; and he performs his annual revolution, in about 687 of our days: his diameter is 4120 miles. Then follow four very small planets, Juno, Ceres, Pallas and Vesta, which have been recently discovered, but whose dimensions, and distances from the sun, have not been very accurately ascertained. They are generally called asteroids.

Jupiter is next in order: this is the largest of all the planets. He is about 490 millions of miles from the sun, and completes his annual period in nearly 12 of our years. He turns round his axis in about ten hours. He is above 1200 times as big as our earth; his diameter is 86,000 miles. The respective proportions of the planets cannot, therefore, you see, be conveniently delineated in a diagram. He is attended by four moons. [Pg 85]

The next planet is Saturn, whose distance from the sun, is about 900 millions of miles; his diurnal rotation is performed in 10 hours and a quarter: his annual revolution is nearly 30 of our years. His diameter is 79,000 miles. This planet is surrounded by a luminous ring, the nature of which, astronomers are much at a loss to conjecture: he has seven moons. Lastly, we observe the planet Herschel, discovered by Dr. Herschel, by whom it was named the Georgium Sidus, and which is attended by six moons.

Caroline. How charming it must be in the distant planets, to see several moons shining at the same time; I think I should like to be an inhabitant of Jupiter or Saturn.

Mrs. B. Not long I believe. Consider what extreme cold must prevail in a planet, situated as Saturn is, at nearly ten times the distance at which we are from the sun. Then his numerous moons are far from making so splendid an appearance as ours; for they can reflect only the light which they receive from the sun; and both light, and heat, decrease in the same ratio or proportion to the distances, as gravity. Can you tell me now how much more light we enjoy than Saturn?

Caroline. The square of ten is a hundred; therefore, Saturn has a hundred times less—or to answer your question exactly, we have a hundred times more light and heat, than Saturn—this certainly does not increase my wish to become one of the poor wretches who inhabit that planet.

Mrs. B. May not the inhabitants of Mercury, with equal plausibility, pity us for the insupportable coldness of our situation; and those of Jupiter and Saturn for our intolerable heat? The Almighty power which created these planets, and placed them in their several orbits, has no doubt peopled them with beings, whose bodies are adapted to the various temperatures and elements, in which they are situated. If we judge from the analogy of our own earth, or from that of the great and universal beneficence of Providence, we must conclude this to be the case.

Caroline. Are not comets, in some respects similar to planets?

Mrs. B. Yes, they are; for by the reappearance of some of them, at stated times, they are known to revolve round the sun; but in orbits so extremely eccentric, that they disappear for a great number of years. If they are inhabited, it must be by a species of beings very different, not only from the inhabitants of this, but from those of any of the other planets, as they must experience the greatest vicissitudes of heat and cold; one part of their orbit being so near the sun, that their heat, when there, is computed to be greater than that of red-hot iron; in this part of its orbit, the comet emits a luminous vapour, called the tail, which it gradually loses as it recedes from the sun; and the comet itself totally disappears from our sight, in the more distant parts of its orbit, which extends considerably beyond that of the furthest planet. [Pg 86]

The number of comets belonging to our system cannot be ascertained, as some of them are several centuries before they make their reappearance. The number that are known by their regular reappearance is, I believe, only three, although their whole number is very considerable.

Emily. Pray, Mrs. B., what are the constellations?

Mrs. B. They are the fixed stars; which the ancients, in order to recognise them, formed into groups, and gave the names of the figures, which you find delineated on the celestial globe. In order to show their proper situations in the heavens, they should be painted on the internal surface of a hollow sphere, from the centre of which you should view them; you would then behold them as they appear to be situated in the heavens. The twelve constellations, called the signs of the zodiac, are those which are so situated, that the earth, in its annual revolution, passes directly between them, and the sun. Their names are Aries, Taurus, Gemini, Cancer, Leo, Virgo, Libra, Scorpio, Sagittarius, Capricornus, Aquarius, Pisces; the whole occupying a complete

circle, or broad belt, in the heavens, called the zodiac. ([plate 8. fig. 1.](#)) Hence, a right line drawn from the earth, and passing through the sun, would reach one of these constellations, and the sun is said to be in that constellation at which the line terminates: thus, when the earth is at A, the sun would appear to be in the constellation or sign Aries; when the earth is at B, the sun would appear in Cancer; when the earth was at C, the sun would be in Libra; and when the earth was at D, the sun would be in Capricorn. You are aware that it is the real motion of the earth in its orbit, which gives to the sun this apparent motion through the signs. This circle, in which the sun thus appears to move, and which passes through the middle of the zodiac, is called the ecliptic.

Caroline. But many of the stars in these constellations appear beyond the zodiac.

PLATE VIII.

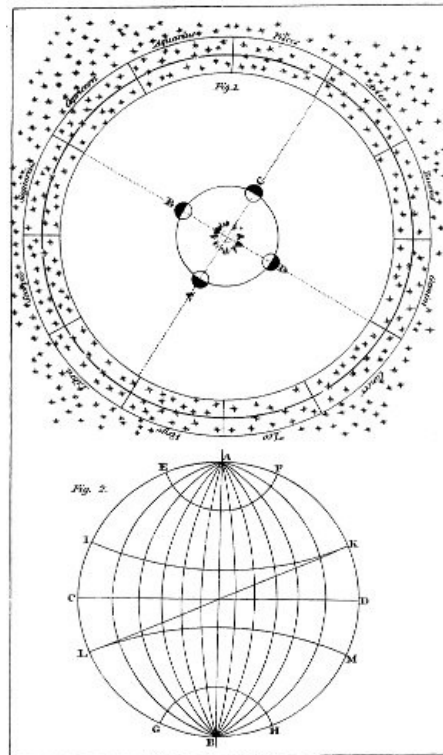

Mrs. B. We have no means of ascertaining the distance of the fixed stars. When, therefore, they are said to be in the zodiac, it is merely implied that they are situated in that direction, and that they shine upon us through that portion of the heavens, which we call the zodiac. [Pg 87]

Emily. But are not those large bright stars, which are called stars of the first magnitude, nearer to us, than those small ones which we can scarcely discern?

Mrs. B. It may be so; or the difference of size and brilliancy of the stars may proceed from their difference of dimensions; this is a point which astronomers are not enabled to determine. Considering them as suns, I see no reason why different suns should not vary in dimensions, as well as the planets belonging to them.

Emily. What a wonderful and beautiful system this is, and how astonishing to think that every fixed star may probably be attended by a similar train of planets!

Caroline. You will accuse me of being very incredulous, but I cannot help still entertaining some doubts, and fearing that there is more beauty than truth in this system. It certainly may be so; but there does not appear to me to be sufficient evidence to prove it. It seems so plain and obvious that the earth is motionless, and that the sun and stars revolve round it;—your solar system, you must allow, is directly in opposition to the evidence of our senses.

Mrs. B. Our senses so often mislead us, that we should not place implicit reliance upon them.

Caroline. On what then can we rely, for do we not receive all our ideas through the medium of our senses?

Mrs. B. It is true that they are our primary source of knowledge; but the mind has the power of reflecting, judging, and deciding upon the ideas received by the organs of sense. This faculty, which we call reason, has frequently proved to us, that our senses are liable to err. If you have ever sailed on the water, with a very steady breeze, you must have seen the houses, trees, and every object on the shore move, while you were sailing.

Caroline. I remember thinking so, when I was very young; but I now know that their motion is only apparent. It is true that my reason, in this case, corrects the error of my sight.

Mrs. B. It teaches you, that the apparent motion of the objects on shore, proceeds from your being yourself moving, and that you are not sensible of your own motion, because you meet with no resistance. It is only when some obstacle impedes our motion, that we are conscious of moving; and if you were to close your eyes when you were sailing on calm water, with a steady [Pg 88]

wind, you would not perceive that you moved, for you could not feel it, and you could see it only by observing the change of place of the objects on shore. So it is with the motion of the earth: every thing on its surface, and the air that surrounds it, accompanies it in its revolution; it meets with no resistance: therefore, like the crew of a vessel sailing with a fair wind, in a calm sea, we are insensible of our motion.

Caroline. But the principal reason why the crew of a vessel in a calm sea do not perceive their motion, is, because they move exceedingly slow, while the earth, you say, revolves with great velocity.

Mrs. B. It is not because they move slowly, but because they move steadily, and meet with no irregular resistances, that the crew of a vessel do not perceive their motion; for they would be equally insensible to it, with the strongest wind, provided it were steady, that they sailed with it, and that it did not agitate the water; but this last condition, you know, is not possible, for the wind will always produce waves which offer more or less resistance to the vessel, and then the motion becomes sensible, because it is unequal.

Caroline. But, granting this, the crew of a vessel have a proof of their motion, which the inhabitants of the earth cannot have,—the apparent motion of the objects on shore, or their having passed from one place to another.

Mrs. B. Have we not a similar proof of the earth's motion, in the apparent motion of the sun and stars? Imagine the earth to be sailing round its axis, and successively passing by every star, which, like the objects on land, we suppose to be moving instead of ourselves. I have heard it observed by an aerial traveller in a balloon, that the earth appears to sink beneath the balloon, instead of the balloon rising above the earth.

It is a law which we discover throughout nature, and worthy of its great Author, that all its purposes are accomplished by the most simple means; and what reason have we to suppose this law infringed, in order that we may remain at rest, while the sun and stars move round us; their regular motions, which are explained by the laws of attraction, on the first supposition, would be unintelligible on the last, and the order and harmony of the universe be destroyed. Think what an immense circuit the sun and stars would make daily, were their apparent motions, real. We know many of them, to be bodies more considerable than our earth; for our eyes vainly endeavour to persuade us, that they are little brilliants sparkling in the heavens; while science teaches us that they are immense spheres, whose apparent dimensions are diminished by distance. Why then should these enormous globes daily traverse such a prodigious space, merely to prevent the necessity of our earth's revolving on its axis?

[Pg 89]

Caroline. I think I must now be convinced. But you will, I hope, allow me a little time to familiarise to myself, an idea so different from that which I have been accustomed to entertain. And pray, at what rate do we move?

Mrs. B. The motion produced by the revolution of the earth on its axis, is about seventeen miles a minute, to an inhabitant on the equator.

Emily. But does not every part of the earth move with the same velocity?

Mrs. B. A moment's reflection would convince you of the contrary: a person at the equator must move quicker than one situated near the poles, since they both perform a revolution in 24 hours.

Emily. True, the equator is farthest from the axis of motion. But in the earth's revolution round the sun, every part must move with equal velocity?

Mrs. B. Yes, about a thousand miles a minute.

Caroline. How astonishing!—and that it should be possible for us to be insensible of such a rapid motion. You would not tell me this sooner, Mrs. B., for fear of increasing my incredulity.

Before the time of Newton, was not the earth supposed to be in the centre of the system, and the sun, moon, and stars to revolve round it?

Mrs. B. This was the system of Ptolemy, in ancient times; but as long ago as the beginning of the sixteenth century it was generally discarded, and the solar system, such as I have shown you, was established by the celebrated astronomer Copernicus, and is hence called the Copernican system. But the theory of gravitation, the source from which this beautiful and harmonious arrangement flows, we owe to the powerful genius of Newton, who lived at a much later period, and who demonstrated its truth.

Emily. It appears, indeed, far less difficult to trace by observation the motion of the planets, than to divine by what power they are impelled and guided. I wonder how the idea of gravitation could first have occurred to sir Isaac Newton?

[Pg 90]

Mrs. B. It is said to have been occasioned by a circumstance from which one should little have expected so grand a theory to have arisen.

During the prevalence of the plague in the year 1665, Newton retired into the country to avoid the contagion: when sitting one day in an orchard, he observed an apple fall from a tree, and was led to consider what could be the cause which brought it to the ground.

Caroline. If I dared to confess it, Mrs. B., I should say that such an inquiry indicated rather a

deficiency than a superiority of intellect. I do not understand how any one can wonder at what is so natural and so common.

Mrs. B. It is the mark of superior genius to find matter for wonder, observation, and research, in circumstances which, to the ordinary mind, appear trivial, because they are common; and with which they are satisfied, because they are natural; without reflecting that nature is our grand field of observation, that within it, is contained our whole store of knowledge; in a word, that to study the works of nature, is to learn to appreciate and admire the wisdom of God. Thus, it was the simple circumstance of the fall of an apple, which led to the discovery of the laws upon which the Copernican system is founded; and whatever credit this system had obtained before, it now rests upon a basis from which it cannot be shaken.

Emily. This was a most fortunate apple, and more worthy to be commemorated than all those that have been sung by the poets. The apple of discord for which the goddesses contended; the golden apples by which Atalanta won the race; nay, even the apple which William Tell shot from the head of his son, cannot be compared to this!

Questions

1. (Pg. 80) Into what two classes are the planets divided, and how are they distinguished?
2. (Pg. 80) By what reasoning do you prove that the sun contains a greater quantity of matter than any other body in the system?
3. (Pg. 81) What two circumstances govern the force with which bodies attract each other?
4. (Pg. 81) Were a planet removed to double its former distance from the sun, what would be the effect upon its attractive force?
5. (Pg. 81) Why would it be reduced to one-fourth?
6. (Pg. 81) What is meant by the square of a number, and what examples can you give?
7. (Pg. 81) What then would be the effect of removing it to three, or four times its former distance?
8. (Pg. 81) How is the rule upon this subject expressed?
9. (Pg. 81) Does this apply to any power excepting gravitation?
10. (Pg. 81) How is it that a secondary planet revolves round its primary, and is not drawn off by the sun?
11. (Pg. 82) What is said respecting the revolution of the moon, and of the earth, round a common centre of gravity?
12. (Pg. 82) By what law in mechanics is this explained?
13. (Pg. 82) What motions then has the earth, and are these remarks confined to it alone?
14. (Pg. 82) What effect have the planets upon the sun, and what is said of the common centre of gravity of the system?
15. (Pg. 83) What other motion has the sun, and how is it proved?
16. (Pg. 83) How may you observe the motion of a planet, by means of a fixed star?
17. (Pg. 83) What is represented by [fig. 1. plate 7](#)?
18. (Pg. 83) Why are the orbits represented as circular?
19. (Pg. 83) In what order do the planets increase in size as represented, [fig. 2. plate 7](#)?
20. (Pg. 83) What are we told respecting Mercury?
21. (Pg. 84) What respecting Venus?
22. (Pg. 84) When does Venus become a morning, and when an evening star?
23. (Pg. 84) What is said of the Earth?
24. (Pg. 84) What of Mars?
25. (Pg. 84) What four small planets follow next?
26. (Pg. 85) What is said of Jupiter?
27. (Pg. 85) What of Saturn?
28. (Pg. 85) What of Herschel?
29. (Pg. 85) Why do we conclude that the moons of Saturn afford less light than ours?
30. (Pg. 85) In what proportion will the light and heat at Saturn be diminished, and why?
31. (Pg. 86) What do the comets resemble, and what is remarkable in their orbits?
32. (Pg. 86) What is said of the number of comets?
33. (Pg. 86) What is a constellation?
34. (Pg. 86) How are the twelve constellations, or signs, called the zodiac, situated?
35. (Pg. 86) Name them.
36. (Pg. 86) What is meant by the sun being in a sign?
37. (Pg. 86) What causes the apparent change of the sun's place?
38. (Pg. 87) The stars appear of different magnitudes, by what may this be caused?
39. (Pg. 87) We are not sensible of the motion of the earth; what fact is mentioned to illustrate this point?
40. (Pg. 87) What does this teach us?
41. (Pg. 88) Would the slowness, or the rapidity of the motion, if steady, produce any sensible difference?
42. (Pg. 88) If we do not feel the motion of the earth, how may we be convinced of its reality?
43. (Pg. 89) Were we to deny the motion of the earth upon its axis, what must we admit respecting the heavenly bodies?
44. (Pg. 89) What distance is an inhabitant on the equator carried in a minute by the diurnal motion of the earth?
45. (Pg. 89) Why is not the velocity every where equally great?
46. (Pg. 89) What distance does the earth travel in a minute, in its revolution round the sun?
47. (Pg. 89) What was formerly supposed respecting the motion of all the heavenly bodies?
48. (Pg. 89) What do we mean by the Copernican system, and what is said respecting Copernicus and Newton?
49. (Pg. 90) What circumstance is said to have given rise to the speculations of Newton, on the subject of gravitation?

CONVERSATION VIII. ON THE EARTH.

OF THE TERRESTRIAL GLOBE. OF THE FIGURE OF THE EARTH. OF THE PENDULUM. OF THE VARIATION OF THE SEASONS, AND OF THE LENGTH OF DAYS AND NIGHTS. OF THE CAUSES OF THE HEAT OF SUMMER. OF SOLAR, SIDERIAL, AND EQUAL OR MEAN TIME.

MRS. B.

As the earth is the planet in which we are the most particularly interested, it is my intention this morning, to explain to you the effects resulting from its annual, and diurnal motions; but for this purpose, it will be necessary to make you acquainted with the terrestrial globe: you have not either of you, I conclude, learnt the use of the globes?

Caroline. No; I once indeed, learnt by heart, the names of the lines marked on the globe, but as I was informed they were only imaginary divisions, they did not appear to me worthy of much attention, and were soon forgotten.

Mrs. B. You supposed, then, that astronomers had been at the trouble of inventing a number of lines, to little purpose. It will be impossible for me to explain to you the particular effects of the earth's motion, without your having acquired a knowledge of these lines: in [plate 8. fig. 2.](#) you will find them all delineated: and you must learn them perfectly, if you wish to make any proficiency in astronomy.

Caroline. I was taught them at so early an age, that I could not understand their meaning; and I have often heard you say, that the only use of words, was to convey ideas.

Mrs. B. A knowledge of these lines, would have conveyed some idea of the manner in which they were designed to divide the globe into parts; although the use of these divisions, might at that time, have been too difficult for you to understand. Childhood is the season, when impressions on the memory are most strongly and most easily made: it is the period at which a large stock of terms should be treasured up, the precise application of which we may learn when the understanding is more developed. It is, I think, a very mistaken notion, that children should be taught such things only, as they can perfectly understand. Had you been early made acquainted with the terms which relate to figure and motion, how much it would have facilitated your progress in natural philosophy. I have been obliged to confine myself to the most common and familiar expressions, in explaining the laws of nature; although I am convinced that appropriate and scientific terms, might have conveyed more precise and accurate ideas, had you been prepared to understand them.

[Pg 92]

Emily. You may depend upon our carefully learning the names of these lines, Mrs. B.; but before we commit them to memory, will you have the goodness to explain them to us?

Mrs. B. Most willingly. This figure of a globe, or sphere, represents the earth; the line which passes through its centre, and on which it turns, is called its axis, and the two extremities of the axis A and B, are the poles, distinguished by the names of the north and the south pole. The circle C D, which divides the globe into two equal parts between the poles, and equally distant from them, is called the equator, or equinoctial line; that part of the globe to the north of the equator, is the northern hemisphere; that part to the south of the equator, the southern hemisphere. The small circle E F, which surrounds the north pole, is called the arctic circle; that G H, which surrounds the south pole, the antarctic circle; these are also called polar circles. There are two circles, intermediate between the polar circles and the equator; that to the north I K, called the tropic of Cancer; that to the south, L M, called the tropic of Capricorn. Lastly, this circle, L K, which divides the globe into two equal parts, crossing the equator and extending northward as far as the tropic of Cancer, and southward as far as the tropic of Capricorn, is called the ecliptic. The delineation of the ecliptic on the terrestrial globe is not without danger of conveying false ideas; for the ecliptic (as I have before said) is an imaginary circle in the heavens, passing through the middle of the zodiac, and situated in the plane of the earth's orbit.

Caroline. I do not understand the meaning of the plane of the earth's orbit.

Mrs. B. A plane, is an even flat surface. Were you to bend a piece of wire, so as to form a hoop, you might then stretch a piece of cloth, or paper over it, like the head of a drum; this would form a flat surface, which might be called the plane of the hoop. Now the orbit of the earth, is an imaginary circle, surrounding the sun, and you can readily imagine a plane extending from one side of this circle to the other, filling up its whole area: such a plane would pass through the centre of the sun, dividing it into hemispheres. You may then imagine this plane extended beyond the limits of the earth's orbit, on every side, until it reached those fixed stars which form the signs of the zodiac; passing through the middle of these signs, it would give you the place of that imaginary circle in the heavens, call the ecliptic; which is the sun's apparent path. Let [fig. 1. plate 9.](#) represent such a plane, S the sun, E the earth with its orbit, and A B C D the ecliptic passing through the middle of the zodiac.

[Pg 93]

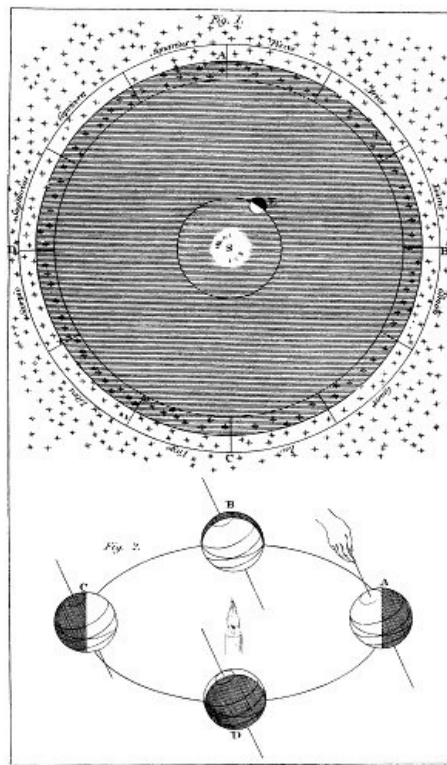

Emily. If the ecliptic relates only to the heavens, why is it described upon the terrestrial globe?

Mrs. B. It is convenient for the demonstration of a variety of problems in the use of the globes; and besides, the obliquity of this circle to the equator is rendered more conspicuous by its being described on the same globe; and the obliquity of the ecliptic shows how much the earth's axis is inclined to the plane of its orbit. But to return to [fig. 2. plate 8.](#)

The spaces between the several parallel circles on the terrestrial globe are called zones: that which is comprehended between the tropics is distinguished by the name of the torrid zone; the spaces which extend from the tropics to the polar circles, the north and south temperate zones; and the spaces contained within the polar circles, the frigid zones. By the term zone is meant a belt, or girdle, the frigid zones, however, are not belts, but circles, extending $23\frac{1}{2}$ degrees from their centres, the poles.

The several lines which, you observe to be drawn from one pole to the other, cutting the equator at right angles, are called meridians; the number of these is unlimited, as a line passing through any place, directly to the poles, is called the meridian of that place. When any one of these meridians is exactly opposite to the sun, it is mid-day, or twelve o'clock in the day, at all the places situated any where on that meridian; and, at the places situated on the opposite meridian, it is consequently midnight.

Emily. To places situated equally distant from these two meridians, it must then be six o'clock.

Mrs. B. Yes; if they are to the east of the sun's meridian it is six o'clock in the afternoon, because they will have previously passed the sun; if to the west, it is six o'clock in the morning, and that meridian will be proceeding towards the sun.

[Pg 94]

Those circles which divide the globe into two equal parts, such as the equator and the ecliptic, are called greater circles; to distinguish them from those which divide it into two unequal parts, as the tropics, and polar circles, which are called lesser circles. All circles, you know, are imagined to be divided into 360 equal parts, called degrees, and degrees are again divided into 60 equal parts, called minutes. The diameter of a circle is a right line drawn across it, and passing through its centre; were you, for instance, to measure across this round table, that would give you its diameter; but were you to measure all round the edge of it, you would then obtain its circumference.

Now Emily, you may tell me exactly how many degrees are contained in a meridian?

Emily. A meridian, reaching from one pole to the other, is half a circle, and must therefore contain 180 degrees.

Mrs. B. Very well; and what number of degrees are there from the equator to one of the poles?

Caroline. The equator being equally distant from either pole, that distance must be half of a meridian, or a quarter of the circumference of a circle, and contain 90 degrees.

Mrs. B. Besides the usual division of circles into degrees, the ecliptic is divided into twelve equal parts, called signs, which bear the name of the constellations through which this circle passes in the heavens. The degrees measured on the meridians from the equator, either towards the north, or towards the south, are called degrees of latitude, of which there may be 90; those measured

from east to west, either on the equator, or any of the lesser circles, are called degrees of longitude, of which there may be 180; these lesser circles are also called parallels of latitude. Of these parallels there may be any number; a circle drawn from east to west, at any distance from the equator, will always be parallel to it, and is therefore called a parallel of latitude.

Emily. The degrees of longitude must then vary in length, according to the dimensions of the circle on which they are reckoned; those, for instance, at the polar circles, will be considerably smaller than those at the equator?

[Pg 95]

Mrs. B. Certainly; since the degrees of circles of different dimensions do not vary in number, they must necessarily vary in length. The degrees of latitude, you may observe, never vary in length; for the meridians on which they are reckoned are all of the same dimensions.

Emily. And of what length is a degree of latitude?

Mrs. B. Sixty geographical miles, which is equal to $69\frac{1}{2}$ English statute miles; or about one-sixth more than a common mile.

Emily. The degrees of longitude at the equator, must then be of the same dimensions, with a degree of latitude.

Mrs. B. They would, were the earth a perfect sphere; but it is not exactly such, being somewhat protuberant about the equator, and flattened towards the poles. This form proceeds from the superior action of the centrifugal power at the equator, and as this enlarges the circle, it must, in the same proportion, increase the length of the degrees of longitude measured on it.

Caroline. I thought I had understood the centrifugal force perfectly, but I do not comprehend its effects in this instance.

Mrs. B. You know that the revolution of the earth on its axis, must give to every particle a tendency to fly off from the centre, that this tendency is stronger, or weaker, in proportion to the velocity with which the particle moves; now a particle situated near to one of the poles, makes one rotation in the same space of time as a particle at the equator; the latter, therefore, having a much larger circle to describe, travels proportionally faster, consequently the centrifugal force is much stronger at the equator than in the polar regions: it gradually decreases as you leave the equator and approach the poles, at which points the centrifugal force, entirely ceases. Supposing, therefore, the earth to have been originally in a fluid state, the particles in the torrid zone would recede much farther from the centre than those in the frigid zones; thus the polar regions would become flattened, and those about the equator elevated.

As a large portion of the earth is covered with water, the Creator gave to it the form, denominated an *oblate spheroid*, otherwise the polar regions would have been without water, and those about the equator, would have been buried several miles below the surface of the ocean.

[Pg 96]

Caroline. I did not consider that the particles in the neighbourhood of the equator, move with greater velocity than those about the poles; this was the reason I could not understand you.

Mrs. B. You must be careful to remember, that those parts of a body which are farthest from the centre of motion, must move with the greatest velocity: the axis of the earth is the centre of its diurnal motion, and the equatorial regions the parts most distant from the axis.

Caroline. My head then moves faster than my feet; and upon the summit of a mountain, we are carried round quicker than in a valley?

Mrs. B. Certainly; your head is more distant from the centre of motion than your feet; the mountain-top than the valley; and the more distant any part of a body is from the centre of motion, the larger is the circle it will describe, and the greater therefore must be its velocity.

Emily. I have been reflecting, that if the earth is not a perfect circle—

Mrs. B. A sphere you mean, my dear: a circle is a round line, every part of which is equally distant from the centre; a sphere or globe is a round body, the surface of which is every where equally distant from the centre.

Emily. If, then, the earth is not a perfect sphere, but prominent at the equator, and depressed at the poles, would not a body weigh heavier at the equator than at the poles? For the earth being thicker at the equator, the attraction of gravity perpendicularly downwards must be stronger.

Mrs. B. Your reasoning has some plausibility, but I am sorry to be obliged to add, that it is quite erroneous; for the nearer any part of the surface of a body is to the centre of attraction, the more strongly it is attracted; because it is then nearest to the whole mass of attracting matter. In regard to its effects, you might consider the whole power of gravity, as placed at the centre of attraction.

Emily. But were you to penetrate deep into the earth, would gravity increase as you approached the centre?

Mrs. B. Certainly not; I am referring only to any situation on the surface of the earth. Were you to penetrate into the interior, the attraction of the parts above you, would counteract that of the parts beneath you, and consequently diminish the power of gravity in proportion as you approach the centre; and if you reached that point, being equally attracted by the parts all around you, the effects of gravity would cease, and you would be without weight.

[Pg 97]

Emily. Bodies, then, should weigh less at the equator than at the poles, since they are more distant from the centre of gravity in the former than in the latter situation?

Mrs. B. And this is really the case; but the difference of weight would be scarcely sensible, were it not augmented by another circumstance.

Caroline. And what is this singular circumstance, which seems to disturb the laws of nature?

Mrs. B. One that you are well acquainted with, as conducing more to the preservation than the destruction of order,—the centrifugal force. This we have just observed to be strongest at the equator; and as it tends to drive bodies from the centre, it is necessarily opposed to, and must lessen the power of gravity, which attracts them towards the centre. We accordingly find that bodies weigh lightest at the equator, where the centrifugal force is greatest; and heaviest at the poles, where this power is least: the weight being diminished at the equator, by both the causes mentioned.

Caroline. Has the experiment been made in these different situations?

Mrs. B. Louis XIV. of France, sent philosophers both to the equator, and to Lapland, for this purpose: the severity of the climate, and obstruction from the ice, have hitherto rendered every attempt to reach the pole abortive; but the difference of gravity at the equator, and in Lapland is very perceptible.

Caroline. Yet I do not comprehend how the difference of weight could be ascertained, for if the body under trial decreased in weight, the weight which was opposed to it in the opposite scale must have diminished in the same proportion. For instance, if a pound of sugar did not weigh so heavy at the equator as at the poles, the leaden pound which served to weigh it, would not be so heavy either; therefore they would still balance each other, and the different force of gravity could not be ascertained by this means.

Mrs. B. Your observation is perfectly just: the difference of gravity in bodies situated at the poles, and at the equator, cannot be ascertained by weighing them; a pendulum was therefore used for that purpose.

Caroline. What, the pendulum of a clock? how could that answer the purpose?

[Pg 98]

Mrs. B. A pendulum consists of a line, or rod, to one end of which a weight is attached, and by the other end it is suspended to a fixed point, about which it is made to vibrate. When not in motion, a pendulum, obeying the general law of attraction, hangs like a plumb line, perpendicular to the surface of the earth, but if you raise the pendulum, gravity will bring it back to its perpendicular position. It will, however, not remain stationary there, for the momentum it has acquired during its descent, will impel it onwards, and if unobstructed, it will rise on the opposite side to an equal height; from thence it is brought back by gravity, and is again forced upwards, by the impulse of its momentum.

Caroline. If so, the motion of a pendulum would be perpetual, and I thought you said, that there was no perpetual motion on the earth.

Mrs. B. The motion of a pendulum is opposed by the resistance of the air in which it vibrates, and by the friction of the part by which it is suspended: were it possible to remove these obstacles, the motion of a pendulum would be perpetual, and its vibrations perfectly regular; each being of equal distance, and performed in equal times.

Emily. That is the natural result of the uniformity of the power which produces these vibrations, for the force of gravity being always the same, the velocity of the pendulum must consequently be uniform.

Caroline. No, Emily, you are mistaken; the force is not every where the same, and therefore the effect will not be so either. I have discovered it, Mrs. B.; since the force of gravity is less at the equator than at the poles, the vibrations of the pendulum will be slower at the former place than at the latter.

Mrs. B. You are perfectly right, Caroline; it was by this means that the difference of gravity was discovered, and the true figure of the earth ascertained.

Emily. But how do they contrive to regulate their time in the equatorial and polar regions? for, since in our part of the earth the pendulum of a clock vibrates exactly once in a second, if it vibrates faster at the poles, and slower at the equator, the inhabitants must regulate their clocks in a manner different from us.

Mrs. B. The only alteration required is to lengthen the pendulum in one case, and to shorten it in the other; for the velocity of the vibrations of a pendulum depends on its length; and when it is said that a pendulum vibrates quicker at the pole than at the equator, it is supposed to be of the same length. A pendulum which vibrates seconds in this latitude is about $39\frac{1}{4}$ inches long. In order to vibrate at the equator in the same space of time, it must be somewhat shorter; and at the poles, it must be proportionally lengthened.

[Pg 99]

The vibrations of a pendulum, resemble the descent of a body on an inclined plane, and are produced by the same cause; now you must recollect, that the greater the perpendicular height of such a plane, in proportion to its length, the more rapid will be the descent of the body; a short pendulum ascends to a greater height than a larger one, in vibrating a given distance, and of

course its descent must be more rapid.

I shall now, I think, be able to explain to you the cause of the variation of the seasons, and the difference in the length of the days and nights in those seasons; both effects resulting from the same cause.

In moving round the sun, the axis of the earth is not perpendicular to the plane of its orbit. Supposing this round table to represent the plane of the earth's orbit, and this little globe, the earth; through this I have passed a wire, representing its axis and poles. In moving round the table, I do not hold the wire perpendicular to it, but obliquely.

Emily. Yes, I understand, the earth does not go round the sun in an upright position, its axis is slanting or oblique; and, it of course, forms an angle with a line drawn perpendicular to the plane of the earth's orbit.

Mrs. B. All the lines, which you learnt in your last lesson, are delineated on this little globe; you must consider the ecliptic as representing the plane of the earth's orbit; and the equator, which crosses the ecliptic in two places, then shows the degree of obliquity of the axis of the earth; which amounts to $23\frac{1}{2}$ degrees, very nearly. The points in which the ecliptic intersects the equator, are called the equinoctial points.

But I believe I shall render the effects of the obliquity of the earth's axis clearer to you, by the revolution of the little globe round a candle, which shall represent the sun. ([Plate IX. fig. 2.](#))

As I now hold it, at A, you see it in the situation in which it is in the midst of summer, or what is called the summer solstice, which is on the 21st of June. [Pg 100]

Emily. You hold the wire awry, I suppose, in order to show that the axis of the earth is not upright?

Mrs. B. Yes; in summer, the north pole is inclined towards the sun. In this season, therefore, the northern hemisphere enjoys much more of his rays than the southern. The sun, you see, now shines over the whole of the north frigid zone, and notwithstanding the earth's diurnal revolution, which I imitate by twirling the ball on the wire, it will continue to shine upon it as long as it remains in this situation, whilst the south frigid zone is at the same time completely in darkness.

Caroline. That is very strange; I never before heard that there was constant day or night in any part of the world! How much happier the inhabitants of the north frigid zone must be than those of the southern; the first enjoy uninterrupted day, while the last are involved in perpetual darkness.

Mrs. B. You judge with too much precipitation; examine a little further, and you will find, that the two frigid zones share an equal fate.

We shall now make the earth set off from its position in the summer solstice, and carry it round the sun; observe that the pole is always inclined in the same direction, and points to the same spot in the heavens. There is a fixed star situated near that spot, which is hence called the north polar star. Now let us stop the earth at B, and examine it in its present situation; it has gone through one quarter of its orbit, and is arrived at that point at which the ecliptic cuts, or crosses, the equator, and which is called the autumnal equinox.

Emily. The sun now shines from one pole to the other, just as it would constantly do, if the axis of the earth were perpendicular to its orbit.

Mrs. B. Because the inclination of the axis is now neither towards the sun, nor in the contrary direction; at this period of the year, the days and nights are equal in every part of the earth. But the next step she takes in her orbit, you see, involves the north pole in darkness, whilst it illumines that of the south; this change was gradually preparing as I moved the earth from summer to autumn; the arctic circle, which was at first entirely illumined, began to have short nights, which increased as the earth approached the autumnal equinox; and the instant it passed that point, the long night of the north pole commences, and the south pole begins to enjoy the light of the sun. We shall now make the earth proceed in its orbit, and you may observe that as it advances, the days shorten and the nights lengthen, throughout the northern hemisphere, until it arrives at the winter solstice, on the 21st of December, when the north frigid zone is entirely in darkness, and the southern has uninterrupted daylight. [Pg 101]

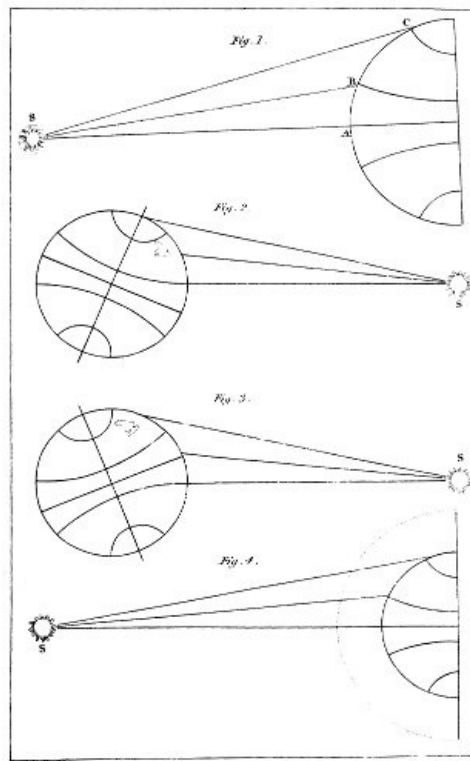

Caroline. Then, after all, the sun which I thought so partial, confers his favours equally on all.

Mrs. B. Not so either: the inhabitants of the torrid zone have much more heat than we have, as the sun's rays fall perpendicularly twice in the course of a year, on every place within the tropics, while they shine more or less obliquely on the rest of the world, and almost horizontally at the poles; for during their long day of six months, the sun moves round their horizon without either rising or setting; the only observable difference, is that it is more elevated by a few degrees at mid-day, than at midnight.

Emily. To a person placed in the temperate zone, in the situation in which we are in England, the sun will shine neither so obliquely as it does on the poles, nor vertically as at the equator; but its rays will fall upon him more obliquely in autumn, and winter, than in summer.

Caroline. And therefore, the inhabitants of the temperate zones, will not have merely one day, and one night, in the year, as happens at the poles, nor will they have equal days, and equal nights, as at the equator; but their days and nights will vary in length, at different times of the year, according as their respective poles incline towards, or from the sun, and the difference will be greater in proportion to their distance from the equator.

Mrs. B. We shall now follow the earth through the other half of her orbit, and you will observe, that now exactly the same changes take place in the southern hemisphere, as those we have just remarked in the northern. Day commences at the south pole, when night sets in at the north pole; and in every other part of the southern hemisphere the days are longer than the nights, while, on the contrary, our nights are longer than our days. When the earth arrives at the vernal equinox, D, where the ecliptic again cuts the equator, on the 21st of March, she is situated, with respect to the sun, exactly in the same position, as in the autumnal equinox; and the only difference with respect to the earth, is, that it is now autumn in the southern hemisphere, whilst it is spring with us.

[Pg 102]

Caroline. Then the days and nights are again every where equal.

Mrs. B. Yes, for the half of the globe which is enlightened, extends exactly from one pole to the other, the sun has just risen to the north pole, and is just setting to the south pole; but in every other part of the globe, the day and night is of twelve hours length; hence the word equinox, which is derived from the Latin, meaning equal night.

As our summer advances, the days lengthen in the northern hemisphere, and shorten in the southern, till the earth reaches the summer solstice, when the north frigid zone is entirely illumined, and the southern is in complete darkness; and we have now brought the earth again to the spot from whence we first accompanied her.

Emily. This is indeed a most satisfactory explanation of the cause of the different lengths of our days and nights, and of the variation of the seasons; and the more I learn, the more I admire the simplicity of means by which such wonderful effects are produced.

Mrs. B. I know not which is most worthy of our admiration, the causes, or the effects of the earth's revolution round the sun. The mind can find no object of contemplation more sublime, than the course of this magnificent globe, impelled by the combined powers of projection and attraction, to roll in one invariable course, around the source of light and heat: and what can be more delightful than the beneficent effects of this vivifying power on its attendant planet. It is at once the grand principle which animates and fecundates nature.

Emily. There is one circumstance in which this little ivory globe appears to me to differ from the earth; it is not quite dark on that side of it which is turned from the candle, as is the case with the earth when neither moon nor stars are visible.

Mrs. B. This is owing to the light of the candle, being reflected by the walls of the room, on every part of the globe, consequently that side of the globe, on which the candle does not directly shine, is not in total darkness. Now the skies have no walls to reflect the sun's light on that side of our earth which is in darkness.

Caroline. I beg your pardon, Mrs. B., I think that the moon, and stars, answer the purpose of walls in reflecting the sun's light to us in the night.

Mrs. B. Very well, Caroline; that is to say, the moon and planets; for the fixed stars, you know, shine by their own light. [Pg 103]

Emily. You say, that the superior heat of the equatorial parts of the earth, arises from the rays falling perpendicularly on those regions, whilst they fall obliquely on these more northern regions; now I do not understand why perpendicular rays should afford more heat than oblique rays.

Caroline. You need only hold your hand perpendicularly over the candle, and then hold it sideways obliquely, to be sensible of the difference.

Emily. I do not doubt the fact, but I wish to have it explained.

Mrs. B. You are quite right; if Caroline had not been satisfied with ascertaining the fact, without understanding it, she would not have brought forward the candle as an illustration; the reason why you feel so much more heat if you hold your hand perpendicularly over the candle, than if you hold it sideways, is because a stream of heated vapour constantly ascends from the candle, or any other burning body, which being lighter than the air of the room, does not spread laterally but rises perpendicularly, and this led you to suppose that the rays were hotter in the latter direction. Had you reflected, you would have discovered that rays issuing from the candle sideways, are no less perpendicular to your hand when held opposite to them, than the rays which ascend when your hand is held over them.

The reason why the sun's rays afford less heat when in an oblique direction, than when perpendicular, is because fewer of them fall upon an equal portion of the earth; this will be understood better by referring to [plate 10. fig. 1](#), which represents two equal portions of the sun's rays, shining upon different parts of the earth. Here it is evident, that the same quantity of rays fall on the space A B, as fall on the space B C; and as A B is less than B C, the heat and light will be much stronger in the former than in the latter; A B, you see, represents the equatorial regions, where the sun shines perpendicularly; and B C, the temperate and frozen climates, where his rays fall more obliquely.

Emily. This accounts not only for the greater heat of the equatorial regions, but for the greater heat of our summers, as the sun shines less obliquely in summer than in winter.

Mrs. B. This you will see exemplified in [figure 2](#), in which the earth is represented, as it is situated on the 21st of June, and England receives less oblique, and consequently a greater number of rays, than at any other season; and [figure 3](#), shows the situation of England on the 21st of December, when the rays of the sun fall most obliquely upon her. But there is also another reason why oblique rays give less heat, than perpendicular rays; which is, that they have a greater portion of the atmosphere to traverse; and though it is true, that the atmosphere is itself a transparent body, freely admitting the passage of the sun's rays, yet it is always loaded more or less with dense and foggy vapour, which the rays of the sun cannot easily penetrate; therefore, the greater the quantity of atmosphere the sun's rays have to pass through in their way to the earth, the less heat they will retain when they reach it. This will be better understood, by referring to [fig. 4](#). The dotted line round the earth, describes the extent of the atmosphere, and the lines which proceed from the sun to the earth, the passage of two equal portions of the sun's rays, to the equatorial and polar regions; the latter you see, from its greater obliquity, passes through a greater extent of atmosphere. [Pg 104]

Caroline. And this, no doubt, is the reason why the sun, in the morning and in the evening, gives so much less heat, than at mid-day.

Mrs. B. The diminution of heat, morning and evening, is certainly owing to the greater obliquity of the sun's rays; and they are also affected by the other, both the cause, which I have just explained to you; the difficulty of passing through a foggy atmosphere is perhaps more particularly applicable to them, as mist and vapours are prevalent about the time of sunrise and sunset. But the diminished obliquity of the sun's rays, is not the sole cause of the heat of summer; the length of the days greatly conduces to it; for the longer the sun is above the horizon, the more heat he will communicate to the earth.

Caroline. Both the longest days, and the most perpendicular rays, are on the 21st of June; and yet the greatest heat prevails in July and August.

Mrs. B. Those parts of the earth which are once heated, retain the heat for some length of time, and the additional heat they receive, occasions an elevation of temperature, although the days begin to shorten, and the sun's rays to fall more obliquely. For the same reason, we have generally more heat at three o'clock in the afternoon, than at twelve, when the sun is on the

meridian.

Emily. And pray, have the other planets the same vicissitudes of seasons, as the earth?

[Pg 105]

Mrs. B. Some of them more, some less, according as their axes deviate more or less from the perpendicular, to the plane of their orbits. The axis of Jupiter, is nearly perpendicular to the plane of his orbit; the axes of Mars, and of Saturn, are each, inclined at angles of about sixty degrees; whilst the axis of Venus is believed to be elevated only fifteen or twenty degrees above her orbit; the vicissitudes of her seasons must therefore be considerably greater than ours. For further particulars respecting the planets, I shall refer you to Bonnycastle's Introduction to Astronomy.

I have but one more observation to make to you, relative to the earth's motion; which is, that although we have but 365 days and nights in the year, she performs 366 complete revolutions on her axis, during that time.

Caroline. How is that possible? for every complete revolution must bring the same place back to the sun. It is now just twelve o'clock, the sun is, therefore, on our meridian; in twenty-four hours will it not have returned to our meridian again, and will not the earth have made a complete rotation on its axis?

Mrs. B. If the earth had no progressive motion in its orbit whilst it revolves on its axis, this would be the case; but as it advances almost a degree westward in its orbit, in the same time that it completes a revolution eastward on its axis, it must revolve nearly one degree more in order to bring the same meridian back to the sun.

Caroline. Oh, yes! it will require as much more of a second revolution to bring the same meridian back to the sun, as is equal to the space the earth has advanced in her orbit; that is, nearly a degree; this difference is, however, very little.

Mrs. B. These small daily portions of rotation, are each equal to the three hundred and sixty-fifth part of a circle, which at the end of the year amounts to one complete rotation.

Emily. That is extremely curious. If the earth then, had no other than its diurnal motion, we should have 366 days in the year.

Mrs. B. We should have 366 days in the same period of time that we now have 365; but if we did not revolve round the sun, we should have no natural means of computing years.

You will be surprised to hear, that if time is calculated by the stars instead of the sun, the irregularity which we have just noticed does not occur, and that one complete rotation of the earth on its axis, brings the same meridian back to any fixed star.

[Pg 106]

Emily. That seems quite unaccountable; for the earth advances in her orbit with regard to the fixed stars, the same as with regard to the sun.

Mrs. B. True, but then the distance of the fixed stars is so immense, that our solar system is in comparison to it but a spot, and the whole extent of the earth's orbit but a point; therefore, whether the earth remain stationary, or whether it revolved in its orbit during its rotation on its axis, no sensible difference would be produced with regard to the fixed stars. One complete revolution brings the same meridian back to the same fixed star; hence the fixed stars appear to go round the earth in a shorter time than the sun by three minutes fifty-six seconds of time.

Caroline. These three minutes fifty-six seconds is the time which the earth takes to perform the additional three hundred and sixty-fifth part of the circle, in order to bring the same meridian back to the sun.

Mrs. B. Precisely. Hence the stars gain every day three minutes fifty-six seconds on the sun, which makes them rise that portion of time earlier every day.

When time is calculated by the stars it is called sidereal time; when by the sun, solar, or apparent time.

Caroline. Then a sidereal day is three minutes fifty-six seconds shorter, than a solar day of twenty-four hours.

Mrs. B. I must also explain to you what is meant by a sidereal year.

The common year, called the solar or tropical year, containing 365 days, five hours, forty-eight minutes and fifty-two seconds, is measured from the time the sun sets out from one of the equinoxes, or solstices, till it returns to the same again; but this year is completed, before the earth has finished one entire revolution in its orbit.

Emily. I thought that the earth performed one complete revolution in its orbit, every year; what is the reason of this variation?

Mrs. B. It is owing to the spheroidal figure of the earth. The elevation about the equator produces much the same effect as if a similar mass of matter, collected in the form of a moon, revolved round the equator. When this moon acted on the earth, in conjunction with, or in opposition to the sun, variations in the earth's motion would be occasioned, and these variations produce what is called the precession of the equinoxes.

[Pg 107]

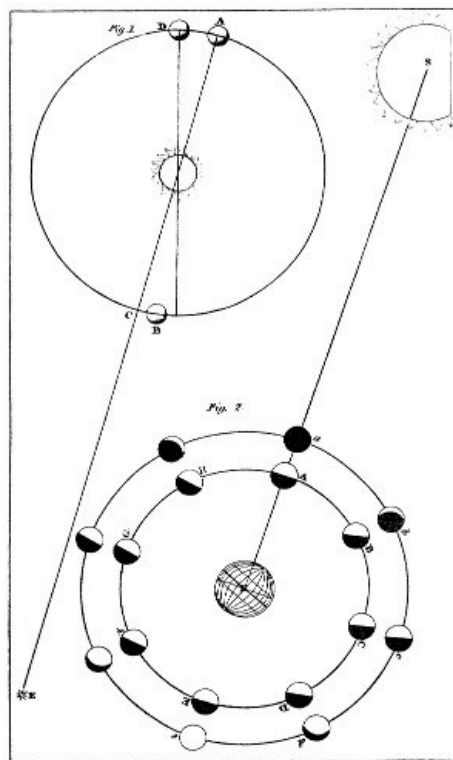

Emily. What does that mean? I thought the equinoctial points, were fixed points in the heavens, in which the equator cuts the ecliptic.

Mrs. B. These points are not quite fixed, but have an apparently retrograde motion, among the signs of the zodiac; that is to say, instead of being at every revolution in the same place, they move backwards. Thus if the vernal equinox is at A, (fig. 1. plate XI.) the autumnal one, will be at B, instead of C, and the following vernal equinox, at D, instead of at A, as would be the case if the equinoxes were stationary, at opposite points of the earth's orbit.

Caroline. So that when the earth moves from one equinox to the other, though it takes half a year to perform the journey, it has not travelled through half its orbit.

Mrs. B. And, consequently, when it returns again to the first equinox, it has not completed the whole of its orbit. In order to ascertain when the earth has performed an entire revolution in its orbit, we must observe when the sun returns in conjunction with any fixed star; and this is called a sidereal year. Supposing a fixed star situated at E, (fig. 1. plate XI.) the sun would not appear in conjunction with it, till the earth had returned to A, when it would have completed its orbit.

Emily. And how much longer is the sidereal, than the solar year?

Mrs. B. Only twenty minutes; so that the variation of the equinoctial points is very inconsiderable. I have given them a greater extent in the figure, in order to render them sensible.

In regard to time, I must further add, that the earth's diurnal motion on an inclined axis, together with its annual revolution in an elliptic orbit, occasions so much complication in its motion, as to produce many irregularities; therefore the true time cannot be measured by the apparent place of the sun. A perfectly correct clock, would in some parts of the year be before the sun, and in other parts after it. There are but four periods in which the sun and a perfect clock would agree, which is the 15th of April, the 16th of June, the 23d of August, and the 24th of December.

Emily. And is there any considerable difference between solar time, and true time?

[Pg 108]

Mrs. B. The greatest difference amounts to between fifteen and sixteen minutes. Tables of equation are constructed for the purpose of pointing out, and correcting these differences between solar time and equal or mean time, which is the denomination given by astronomers, to true time.

Questions

1. (Pg. 92) What does the line A B, (fig. 2 plate 8.) represent, and what are its extremities called?
2. (Pg. 92) What is meant by the equator, and how is it situated?
3. (Pg. 92) There are two hemispheres; how are they named and distinguished?
4. (Pg. 92) What are the circles near the poles called?
5. (Pg. 92) What do the lines I K, and L M, represent?
6. (Pg. 92) What circle is in part represented by the line L K?
7. (Pg. 92) Against what mistake must you guard respecting this line?
8. (Pg. 92) What is meant by a plane, and how could one be represented?
9. (Pg. 93) Describe what is intended by the plane of the earth's orbit.
10. (Pg. 93) Extending this plane to the fixed stars, what circle would it form, and among what particular stars would it be found?

11. (Pg. 93) What is [fig. 1, plate 9](#), designed to represent?
12. (Pg. 93) The ecliptic does not properly belong to the earth, for what purpose then is it described on the terrestrial globe?
13. (Pg. 93) What does the obliquity of the ecliptic to the equator serve to show?
14. (Pg. 93) Within what limits do you find the torrid zone?
15. (Pg. 93) What two zones are there between the torrid, and the two frigid zones?
16. (Pg. 93) Where are the frigid zones situated?
17. (Pg. 93) What is meant by the term zone; and are the frigid zones properly so called?
18. (Pg. 93) How do meridian lines extend, and what is meant by the meridian of a place?
19. (Pg. 93) What is said of the meridian to which the sun is opposite, and where is it then midnight?
20. (Pg. 94) What hour is it then, at places exactly half way between these meridians?
21. (Pg. 94) How are greater and lesser circles distinguished?
22. (Pg. 94) What part of a circle is a degree, and how are these further divided?
23. (Pg. 94) What is the diameter, and what the circumference of a circle, and what proportion do they bear to each other?
24. (Pg. 94) What part of a circle is a meridian?
25. (Pg. 94) How many degrees are there between the equator and the poles?
26. (Pg. 94) Into what parts, besides degrees, is the ecliptic divided?
27. (Pg. 94) How are degrees of latitude measured, and to what number do they extend?
28. (Pg. 94) On what circles are degrees of longitude measured, and to what number do they extend?
29. (Pg. 94) What is a parallel of latitude?
30. (Pg. 95) Degrees of longitude vary in length; what is the cause of this?
31. (Pg. 95) What is the length of a degree of latitude, and why do not these vary?
32. (Pg. 95) What causes the equator to be somewhat larger than a great circle passing through the poles, and what effect has this on degrees of longitude measured on the equator?
33. (Pg. 95) What is the cause of this form being given to the earth?
34. (Pg. 96) What would have been a consequence of the centrifugal force, had the earth been a perfect sphere?
35. (Pg. 96) A body situated at the poles, is attracted more forcibly than if placed at the equator, what is the reason?
36. (Pg. 97) What effect would be produced upon the gravity of a body, were it placed beneath the surface of the earth, and what supposing it at its centre?
37. (Pg. 97) What two circumstances combine, to lessen the weight of a body on the equator?
38. (Pg. 97) Why could not this be proved by weighing a body at the poles, and at the equator?
39. (Pg. 98) What is a pendulum?
40. (Pg. 98) What causes it to vibrate?
41. (Pg. 98) Why are not its vibrations perpetual?
42. (Pg. 98) Two pendulums of the same length, will not, in different latitudes, perform their vibrations in equal times, what is the cause of this?
43. (Pg. 98) To what use has this property of the pendulum been applied?
44. (Pg. 99) What change must be made in pendulums situated at the equator and at the poles, to render their vibrations equal?
45. (Pg. 99) What do the vibrations of a pendulum resemble, and why will it vibrate more rapidly if shortened?
46. (Pg. 99) In the revolution of the earth round the sun, what is the position of its axis?
47. (Pg. 99) How much is the axis of the earth inclined, and with what line does it form this angle?
48. (Pg. 99) What is represented by [fig. 2, plate 9](#)?
49. (Pg. 100) How is the north pole inclined in the middle of our summer, and what effect has this on the north frigid zone?
50. (Pg. 100) In what direction does the north pole always point?
51. (Pg. 100) What is shown by the position of the earth at B, in the figure?
52. (Pg. 100) How does the sun then shine at the poles, and what is the effect on the days and nights?
53. (Pg. 101) When the earth has passed the autumnal equinox, what changes take place at the poles, and also in the whole northern and southern hemispheres?
54. (Pg. 101) Why is the heat greatest within the torrid zone?
55. (Pg. 101) How does the sun appear at the poles, during the period of day there?
56. (Pg. 101) In what will the days and nights differ in the temperate zone, from those at the poles, and at the equator?
57. (Pg. 102) Trace the earth from the winter solstice to the vernal equinox, and inform me what changes take place.
58. (Pg. 102) What takes place at the time of the vernal equinox, and what is meant by the term?
59. (Pg. 102) In proceeding from the vernal equinox to the summer solstice, what changes take place?
60. (Pg. 103) From what cause arises the superior heat of the equatorial regions?
61. (Pg. 103) Why should oblique rays afford less heat than those which are perpendicular?
62. (Pg. 103) How is this explained by [fig. 1, plate 10](#)?
63. (Pg. 103) How do you account for the superior heat of summer, and how is this exemplified in [fig. 2 and 3, plate 10](#)?
64. (Pg. 104) What other cause lessens the intensity of oblique rays?
65. (Pg. 104) How is this explained by [fig. 4](#)?
66. (Pg. 104) What causes conspire to lessen the solar heat in the morning and evening?
67. (Pg. 104) The greatest heat of summer is after the solstice, and the greatest heat of the day, after 12 o'clock, although the sun's rays are then most direct, how is this accounted for?
68. (Pg. 105) Is there any change of seasons in the other planets?

69. (Pg. [105](#)) What is said respecting the axes of Jupiter, of Mars, and of Saturn?
70. (Pg. [105](#)) In 365 days, how many times does the earth revolve on its axis?
71. (Pg. [105](#)) How is this accounted for?
72. (Pg. [105](#)) Do the fixed stars require the same time as the sun, to return to the same meridian?
73. (Pg. [106](#)) How is this accounted for?
74. (Pg. [106](#)) What is meant by the solar and the sidereal day?
75. (Pg. [106](#)) What is the difference in time between them?
76. (Pg. [106](#)) What is the length of the tropical year?
77. (Pg. [107](#)) The solar year is completed before the earth has made a complete revolution in its orbit, by what is this caused?
78. (Pg. [107](#)) What is this called, and what is represented respecting it by [fig. 1, plate 11](#)?
79. (Pg. [107](#)) By what means can we ascertain the period of a complete revolution of the earth in its orbit, as illustrated by the fixed star E, in [fig. 1](#)?
80. (Pg. [107](#)) What difference is there in the length of the solar and sidereal year?
81. (Pg. [107](#)) Why can we not always ascertain the true time by the apparent place of the sun?
82. (Pg. [108](#)) What would be the greatest difference between solar, and true time, as indicated by a perfect clock?

CONVERSATION IX. ON THE MOON.

OF THE MOON'S MOTION. PHASES OF THE MOON. ECLIPSES OF THE MOON. ECLIPSES OF JUPITER'S MOONS. OF LATITUDE AND LONGITUDE. OF THE TRANSITS OF THE INFERIOR PLANETS. OF THE TIDES.

MRS. B.

We shall, to-day, confine our attention to the moon, which offers many interesting phenomena.

The moon revolves round the earth in the space of about twenty-nine days and a half; in an orbit, the plane of which is inclined upwards of five degrees to that of the earth; she accompanies us in our revolution round the sun.

Emily. Her motion then must be of a complicated nature; for as the earth is not stationary, but advances in her orbit, whilst the moon goes round her, the moon, in passing round the sun, must proceed in a sort of scolloped circle.

Mrs. B. That is true; and there are also other circumstances which interfere with the simplicity, and regularity of the moon's motion, but which are too intricate for you to understand at present.

The moon always presents the same face to us, by which it is evident that she turns but once upon her axis, while she performs a revolution round the earth; so that the inhabitants of the moon have but one day, and one night, in the course of a lunar month.

[Pg 109]

Caroline. We afford them, however, the advantage of a magnificent moon to enlighten their long nights.

Mrs. B. That advantage is put partial; for since we always see the same hemisphere of the moon, the inhabitants of that hemisphere alone, can perceive us.

Caroline. One half of the moon then enjoys our light, while the other half has constantly nights of darkness. If there are any astronomers in those regions, they would doubtless be tempted to visit the other hemisphere, in order to behold so grand a luminary as we must appear to them. But, pray, do they see the earth under all the changes, which the moon exhibits to us?

Mrs. B. Exactly so. These changes are called the phases of the moon, and require some explanation. In [fig. 2, plate 11](#), let us say, that S represents the sun, E the earth, and A B C D E F G H, the moon, in different parts of her orbit. When the moon is at A, her dark side being turned towards the earth, we shall not see her as at *a*; but her disappearance is of very short duration, and as she advances in her orbit, we perceive her under the form of a new moon: when she has gone through one eighth of her orbit at B, one quarter of her enlightened hemisphere will be turned towards the earth, and she will then appear horned as at *b*; when she has performed one quarter of her orbit, she shows us one half of her enlightened side, as at *c*, and this is called her first quarter; at *d* she is said to be gibbous, and at *e* the whole of the enlightened side appears to us, and the moon is at full. As she proceeds in her orbit, she becomes again gibbous, and her enlightened hemisphere turns gradually away from us, until she arrives at G, which is her third quarter; proceeding thence she completes her orbit and disappears, and then again resumes her form of a new moon, and passes successively, through the same changes.

When the moon is new, she is said to be in conjunction with the sun, as they are then both in the same direction from the earth; at the time of full moon, she is said to be in opposition, because she and the sun, are at opposite sides of the earth; at the time of her first and third quarters, she

Emily. Are not the eclipses of the sun produced by the moon passing between the sun and the earth?

Mrs. B. Yes; when the moon passes between the sun and the earth, she intercepts his rays, or, in other words, casts a shadow on the earth, then the sun is eclipsed, and daylight gives place to darkness, while the moon's shadow is passing over us.

When, on the contrary, the earth is between the sun and the moon, it is we who intercept the sun's rays, and cast a shadow on the moon; she is then said to be eclipsed, and disappears from our view.

Emily. But as the moon goes round the earth every month, she must be, once during that time, between the earth and the sun; and the earth must likewise be once between the sun and the moon, and yet we have not a solar and a lunar eclipse every month?

Mrs. B. I have already informed you, that the orbits of the earth and moon are not in the same plane, but cross or intersect each other; and the moon generally passes either above or below that of the earth, when she is in conjunction with the sun, and does not therefore intercept its rays, and produce an eclipse; for this can take place only when the moon is in, or near her nodes, which is the name given to those two points in which her orbit crosses that of the earth; eclipses cannot happen at any other time, because it is then only, that they are both in a right line with the sun.

Emily. And a partial eclipse of the moon takes place, I suppose, when, in passing by the earth, she is not sufficiently above or below the shadow, to escape it entirely?

Mrs. B. Yes, one edge of her disk then dips into the shadow, and is eclipsed; but as the earth is larger than the moon, when eclipses happen precisely at the nodes, they are not only total, but last for upwards of three hours.

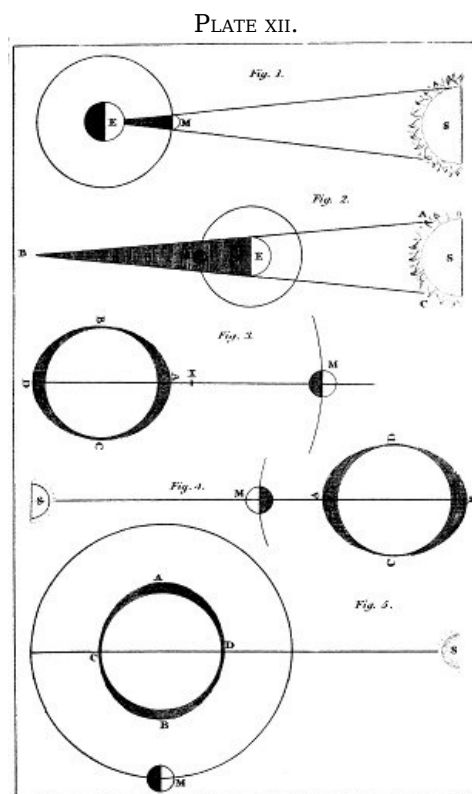

A total eclipse of the sun rarely occurs, and when it happens, the total darkness is confined to one particular part of the earth, the diameter of the shadow not exceeding 180 miles; evidently showing that the moon is smaller than the sun, since she cannot entirely hide it from the earth. In [fig. 1, plate 12](#), you will find a solar eclipse described; S is the sun, M the moon, and E the earth; and the moon's shadow, you see, is not large enough to cover the earth. The lunar eclipses, on the contrary, are visible from every part of the earth, where the moon is above the horizon; and we discover, by the length of time which the moon is passing through the earth's shadow, that it would be sufficient to eclipse her totally, were she many times her actual size; it follows, therefore, that the earth is much larger than the moon.

In [fig. 2](#), S represents the sun, which pours forth rays of light in straight lines, in every direction. E is the earth, and M the moon. Now a ray of light coming from one extremity of the sun's disk, in the direction A B, will meet another, coming from the opposite extremity, in the direction C B; the shadow of the earth cannot therefore extend beyond B; as the sun is larger than the earth, the shadow of the latter is conical, or in the figure of a sugar loaf; it gradually diminishes, and is much smaller than the earth where the moon passes through it, and yet we find the moon to be, not only totally eclipsed, but to remain for a considerable length of time in darkness, and hence

we are enabled to ascertain its real dimensions.

Emily. When the moon eclipses the sun to us, we must be eclipsed to the moon?

Mrs. B. Certainly; for if the moon intercepts the sun's rays, and casts a shadow on us, we must necessarily disappear to the moon, but only partially, as in [fig. 1](#).

Caroline. There must be a great number of eclipses in the distant planets, which have so many moons?

Mrs. B. Yes, few days pass without an eclipse taking place; for among the number of satellites, one or the other of them are continually passing either between their primary and the sun; or between the planet, and each other. Astronomers are so well acquainted with the motion of the planets, and their satellites, that they have calculated not only the eclipses of our moon, but those of Jupiter, with such perfect accuracy, that it has afforded a means of ascertaining the longitude.

Caroline. But is it not very easy to find both the latitude and longitude of any place by a map or globe?

Mrs. B. If you know where you are situated, there is no difficulty in ascertaining the latitude or longitude of the place, by referring to a map; but supposing that you had been a length of time at sea, interrupted in your course by storms, a map would afford you very little assistance in discovering where you were.

[Pg 112]

Caroline. Under such circumstances, I confess I should be equally at a loss to discover either latitude, or longitude.

Mrs. B. The latitude is usually found by taking the altitude of the sun at mid-day; that is to say, the number of degrees that it is elevated above the horizon, for the sun appears more elevated as we approach the equator, and less as we recede from it.

Caroline. But unless you can see the sun, how can you take its altitude?

Mrs. B. When it is too cloudy to see the sun, the latitude is sometimes found at night, by the polar star; the north pole of the earth, points constantly towards one particular part of the heavens, in which a star is situated, called the Polar star: this star is visible on clear nights, from every part of the northern hemisphere; the altitude of the polar star, is therefore the same number of degrees, as that of the pole; the latitude may also be determined by observations made on any of the fixed stars: the situation therefore of a vessel at sea, with regard to north and south, is easily ascertained. The difficulty is, respecting east and west, that is to say, its longitude. As we have no eastern poles from which we can reckon our distance, some particular spot, or line, must be fixed upon for that purpose. The English, reckon from the meridian of Greenwich, where the royal observatory is situated; in French maps, you will find that the longitude is reckoned from the meridian of Paris.

The rotation of the earth on its axis in 24 hours from west to east, occasions, you know, an apparent motion of the sun and stars in a contrary direction, and the sun appears to go round the earth in the space of 24 hours, passing over fifteen degrees, or a twenty-fourth part of the earth's circumference every hour; therefore, when it is twelve o'clock in London, it is one o'clock in any place situated fifteen degrees to the east of London, as the sun must have passed the meridian of that place, an hour before he reaches that of London. For the same reason it is eleven o'clock in any place situated fifteen degrees to the west of London, as the sun will not come to that meridian till an hour later.

If then the captain of a vessel at sea, could know precisely what was the hour at London, he could, by looking at his watch, and comparing it with the hour at the spot in which he was, ascertain the longitude.

[Pg 113]

Emily. But if he had not altered his watch, since he sailed from London, it would indicate the hour it then was in London.

Mrs. B. True; but in order to know the hour of the day at the spot in which he is, the captain of a vessel regulates his watch by the sun when it reaches the meridian.

Emily. Then if he had two watches, he might keep one regulated daily, and leave the other unaltered; the former would indicate the hour of the place in which he was situated, and the latter the hour at London; and by comparing them together, he would be able to calculate his longitude.

Mrs. B. You have discovered, Emily, a mode of finding the longitude, which I have the pleasure to tell you, is universally adopted: watches of a superior construction, called chronometers, or time-keepers, are used for this purpose, and are now made with such accuracy, as not to vary more than four or five seconds in a whole year; but the best watches are liable to imperfections, and should the time-keeper go too fast or too slow, there would be no means of ascertaining the error; implicit reliance, cannot consequently be placed upon them.

Recourse, therefore, is sometimes had to the eclipses of Jupiter's satellites. A table is made, of the precise time at which the several moons are eclipsed to a spectator at London; when they appear eclipsed to a spectator in any other spot, he may, by consulting the table, know what is the hour at London; for the eclipse is visible at the same moment, from whatever place on the

earth it is seen. He has then only to look at his watch, which he regulates by the sun, and which therefore points out the hour of the place in which he is, and by observing the difference of time there, and at London, he may immediately determine his longitude.

Let us suppose, that a certain moon of Jupiter is always eclipsed at six o'clock in the evening; and that a man at sea consults his watch, and finds that it is ten o'clock at night, where he is situated, at the moment the eclipse takes place, what will be his longitude?

Emily. That is four hours later than in London: four times fifteen degrees, make 60; he would, therefore, be sixty degrees east of London, for the sun must have passed his meridian before it reaches that of London.

Mrs. B. For this reason the hour is always later than in London, when the place is east longitude, and earlier when it is west longitude. Thus the longitude can be ascertained whenever the eclipses of Jupiter's moons are visible. [Pg 114]

Caroline. But do not the primary planets, sometimes eclipse the sun from each other, as they pass round in their orbits?

Mrs. B. They must of course sometimes pass between each other and the sun, but as their shadows never reach each other, they hide so little of his light, that the term eclipse is not in this case used; this phenomenon is called a transit. The primary planets do not any of them revolve in the same plane, and the times of their revolution round the sun is considerable, it therefore but rarely happens that they are at the same time, in conjunction with the sun, and in their nodes. It is evident also, that a planet must be inferior (that is within the orbit of another) in order to its apparently passing over the disk of the sun. Mercury, and Venus, have sometimes passed in a right line between us, and the sun, but being at so great a distance from us, their shadows did not extend so far as the earth; no darkness was therefore produced on any part of our globe; but the planet appeared like a small black spot, passing across the sun's disk.

It was by the last transit of Venus, that astronomers were enabled to calculate, with some degree of accuracy, the distance of the earth from the sun, and the dimensions of the latter.

Emily. I have heard that the tides are affected by the moon, but I cannot conceive what influence it can have on them.

Mrs. B. They are produced by the moon's attraction, which draws up the waters of that part of the ocean over which the moon passes, so as to cause it to stand considerably higher than the surrounding parts.

Caroline. Does attraction act on water more powerfully than on land? I should have thought it would have been just the contrary, for land is certainly a more dense body than water?

Mrs. B. Tides do not arise from water being more strongly attracted than land, for this certainly is not the case; but the cohesion of fluids, being much less than that of solid bodies, they more easily yield to the power of gravity; in consequence of which, the waters immediately below the moon, are drawn up by it, producing a full tide, or what is commonly called, high water, at the spot where it happens. So far, the theory of the tides is not difficult to understand.

Caroline. On the contrary, nothing can be more simple; the waters, in order to rise up under the moon, must draw the waters from the opposite side of the globe, and occasion ebb-tide, or low water, in those parts. [Pg 115]

Mrs. B. You draw your conclusion rather too hastily, my dear; for according to your theory, we should have full tide only once in about twenty-four hours, that is, every time that we were below the moon, while we find that in this time we have two tides, and that it is high water with us, and with our antipodes, at the same time.

Caroline. Yet it must be impossible for the moon to attract the sea in opposite parts of the globe, and in opposite directions, at the same time.

Mrs. B. This opposite tide, is rather more difficult to explain, than that which is immediately beneath the moon; with a little attention, however, I hope I shall be able to make you understand the explanation which has been given of it, by astronomers. It must be confessed, however, that the theory upon this subject, is attended with some difficulties. You recollect that the earth and the moon mutually attract each other, but do you suppose that every part of the earth is equally attracted by the moon?

Emily. Certainly not; you have taught us that the force of attraction decreases, with the increase of distance, and therefore that part of the earth which is farthest from the moon, must be attracted less powerfully, than that to which she is nearest.

Mrs. B. This fact will aid us in the explanation which I am about to give to you.

In order to render the question more simple, let us suppose the earth to be every where covered by the ocean, as represented in (fig. 3. pl. 12.) M is the moon, A B C D the earth. Now the waters on the surface of the earth, about A, being more strongly attracted than any other part, will be elevated: the attraction of the moon at B and C being less, and at D least of all. The high tide at A, is accounted for from the direct attraction of the moon; to produce this the waters are drawn from B and C, where it will consequently be low water. At D, the attraction of the moon being considerably decreased, the waters are left relatively high, which height is increased, by the

centrifugal force of the earth being greater at D than at A, in consequence of its greater distance from the common centre of gravity X, between the earth and the moon.

Emily. The tide A, then, is produced by the moon's attraction, and the tide D, is produced by the centrifugal force, and increased by the feebleness of the moon's attraction, in those parts.

[Pg 116]

Caroline. And when it is high water at A and D, it is low water at B and C: now I think I comprehend the nature of the tides, though I confess it is not quite so easy as I at first thought.

But, Mrs. B., why does not the sun produce tides, as well as the moon; for its attraction is greater than that of the moon?

Mrs. B. It would be at an equal distance, but our vicinity to the moon, makes her influence more powerful. The sun has, however, a considerable effect on the tides, and increases or diminishes them as it acts in conjunction with, or in opposition to the moon.

Emily. I do not quite understand that.

Mrs. B. The moon is a month in going round the earth; twice during that time, therefore, at full and at change, she is in the same direction as the sun; both, then, act in conjunction on the earth, and produce very great tides, called spring tides, as represented in [fig. 4](#), at A and B; but when the moon is at the intermediate parts of her orbit, that is in her quadratures, the sun, instead of affording assistance, weakens her power, by acting in opposition to it; and smaller tides are produced, called neap tides, as represented at M, in [fig. 5](#).

Emily. I have often observed the difference of these tides, when I have been at the sea side.

But since attraction is mutual between the moon and the earth, we must produce tides in the moon; and these must be more considerable in proportion as our planet is larger. And yet the moon does not appear of an oval form.

Mrs. B. You must recollect, that in order to render the explanation of the tides clearer, we suppose the whole surface of the earth to be covered with the ocean; but that is not really the case, either with the earth or the moon, and the land which intersects the water, destroys the regularity of the effect. Thus, in flowing up rivers, in passing round points of land, and into bays and inlets, the water is obstructed, and high water must happen much later, than would otherwise be the case.

Caroline. True; we may, however, be certain that whenever it is high water, the moon is immediately over our heads.

Mrs. B. Not so either; for as a similar effect is produced on that part of the globe immediately beneath the moon, and on that part most distant from it, it cannot be over the heads of the inhabitants of both those situations, at the same time. Besides, as the orbit of the moon is very nearly parallel to that of the earth, she is never vertical, but to the inhabitants of the torrid zone.

[Pg 117]

Caroline. In the torrid zone, then, I hope you will grant that the moon is immediately over, or opposite the spots where it is high water?

Mrs. B. I cannot even admit that; for the ocean naturally partaking of the earth's motion, in its rotation from west to east, the moon, in forming a tide, has to contend against the eastern motion of the waves. All matter, you know, by its inertia, makes some resistance to a change of state; the waters, therefore, do not readily yield to the attraction of the moon, and the effect of her influence is not complete, till three hours after she has passed the meridian, where it is full tide.

When a body is impelled by any force, its motion may continue, after the impelling force ceases to act: this is the case with all projectiles. A stone thrown from the hand, continues its motion for a length of time, proportioned to the force given to it: there is a perfect analogy between this effect, and the continued rise of the water, after the moon has passed the meridian at any particular place.

Emily. Pray what is the reason that the tide is three-quarters of an hour later every day?

Mrs. B. Because it is twenty-four hours and three-quarters before the same meridian, on our globe, returns beneath the moon. The earth revolves on its axis in about twenty-four hours; if the moon were stationary, therefore, the same part of our globe would, every twenty-four hours, return beneath the moon; but as during our daily revolution, the moon advances in her orbit, the earth must make more than a complete rotation, in order to bring the same meridian opposite the moon: we are three-quarters of an hour in overtaking her. The tides, therefore, are retarded, for the same reason that the moon rises later by three-quarters of an hour, every day.

We have now, I think, concluded the observations I had to make to you on the subject of astronomy; at our next interview, I shall attempt to explain to you the elements of hydrostatics.

Questions

1. (Pg. [108](#)) In what time does the moon revolve round the earth? what is the inclination of her orbit? and how does she accompany the earth?
2. (Pg. [108](#)) As the moon revolves round the earth, and also accompanies it in its annual revolution, in what form would you draw the moon's orbit?
3. (Pg. [109](#)) What causes the moon always to present the same face to the earth, and what must be the length of a day and night to its inhabitants?

4. (Pg. [109](#)) Can the earth be seen from every part of the moon, and will it always exhibit the same appearance?
5. (Pg. [109](#)) What are the changes of the moon called?
6. (Pg. [109](#)) How are these changes explained by [fig. 2. plate 11](#)?
7. (Pg. [109](#)) What is meant by her first quarter?
8. (Pg. [109](#)) What by her being horned, and her being gibbous?
9. (Pg. [109](#)) What by her being full?
10. (Pg. [109](#)) What by her third quarter?
11. (Pg. [110](#)) What is meant by her conjunction?—what by her being in opposition?—what by her quadratures?
12. (Pg. [110](#)) By what are eclipses of the sun caused?
13. (Pg. [110](#)) What causes eclipses of the moon?
14. (Pg. [110](#)) What is meant by the moon's nodes?
15. (Pg. [110](#)) Why do not eclipses happen at every new and full moon?
16. (Pg. [110](#)) What causes partial eclipses of the moon?
17. (Pg. [110](#)) When the moon is exactly in one of her nodes, what length of time will she be eclipsed?
18. (Pg. [110](#)) Are total eclipses of the sun frequent, and when they happen what is their extent?
19. (Pg. [111](#)) What does this prove respecting the size of the moon?
20. (Pg. [111](#)) What is shown in [fig. 1. plate 12](#)?
21. (Pg. [111](#)) How are lunar eclipses visible, and what is proved by their duration?
22. (Pg. [111](#)) What is illustrated by [fig. 2. plate 12](#)?
23. (Pg. [111](#)) What remark is made respecting those planets which have several moons?
24. (Pg. [111](#)) What use is made of the eclipses of the satellites of Jupiter?
25. (Pg. [112](#)) How is the latitude of a place usually found?
26. (Pg. [112](#)) By what other means may latitude be found?
27. (Pg. [112](#)) From what is longitude reckoned?
28. (Pg. [112](#)) How does the rotation of the earth upon its axis, govern the time at different places?
29. (Pg. [113](#)) What two circumstances, if known, will enable you to find your longitude from a given place?
30. (Pg. [113](#)) By what means may a captain find the time at London, and in the place where his ship may be?
31. (Pg. [113](#)) How may the eclipses of Jupiter's satellites be used to find the longitude?
32. (Pg. [113](#)) Give an example.
33. (Pg. [114](#)) How will you know whether the longitude is east or west?
34. (Pg. [114](#)) What is meant by the transit of a planet?
35. (Pg. [114](#)) Why can we see transits of Venus and Mercury only?
36. (Pg. [114](#)) By what are tides caused?
37. (Pg. [114](#)) Why is not a similar effect produced on the land?
38. (Pg. [115](#)) In what two parts of the world is it high water at the same time?
39. (Pg. [115](#)) What circumstances respecting the decrease of attraction are taken into account, in explaining the tides?
40. (Pg. [115](#)) How are the high tides at A and D, and the low ones at B and C, in [fig. 3. pl. 12](#), accounted for?
41. (Pg. [116](#)) Has the sun any influence on the tides, and why is it less than that of the moon?
42. (Pg. [116](#)) What is meant by spring tides, and how are they produced?
43. (Pg. [116](#)) What by neap tides, and how are they caused?
44. (Pg. [116](#)) What circumstances affect the time of the tide in rivers, bays, &c.?
45. (Pg. [117](#)) Why in the open ocean, is it high water, some hours after the moon has passed the meridian?
46. (Pg. [117](#)) Why are the tides three-quarters of an hour later every day?

CONVERSATION X. ON THE MECHANICAL PROPERTIES OF FLUIDS.

[Pg 118]

DEFINITION OF A FLUID. DISTINCTION BETWEEN FLUIDS AND LIQUIDS. OF NON-ELASTIC FLUIDS. SCARCELY SUSCEPTIBLE OF COMPRESSION. OF THE COHESION OF FLUIDS. OF THEIR GRAVITATION. OF THEIR EQUILIBRIUM. OF THEIR PRESSURE. OF SPECIFIC GRAVITY. OF THE SPECIFIC GRAVITY OF BODIES HEAVIER THAN WATER. OF THOSE OF THE SAME WEIGHT AS WATER. OF THOSE LIGHTER THAN WATER. OF THE SPECIFIC GRAVITY OF FLUIDS.

MRS. B.

We have hitherto confined our attention to the mechanical properties of solid bodies, which have been illustrated, and, I hope, thoroughly impressed upon your memory, by the conversations we have subsequently had, on astronomy. It will now be necessary for me to give you some account of the mechanical properties of fluids—a science which, when applied to liquids, is divided into two parts, hydrostatics and hydraulics. Hydrostatics, treats of the weight and pressure of fluids; and hydraulics, of the motion of fluids, and the effects produced by this motion. A fluid is a

substance which yields to the slightest pressure. If you dip your hand into a basin of water, you are scarcely sensible of meeting with any resistance.

Emily. The attraction of cohesion is then, I suppose, less powerful in fluids, than in solids?

Mrs. B. Yes; fluids, generally speaking, are bodies of less density than solids. From the slight cohesion, of the particles of fluids, and the facility with which they slide over each other, it is inferred, that they have but a slight attraction for each other, and that this attraction is equal, in every position of their particles, and therefore produces no resistance to a perfect freedom of motion among themselves.

Caroline. Pray what is the distinction between a fluid and a liquid?

Mrs. B. Liquids comprehend only one class of fluids. There is another class, distinguished by the name of elastic fluids, or gases, which comprehends the air of the atmosphere, and all the various kinds of air with which you will become acquainted, when you study chemistry. Their mechanical properties we shall examine hereafter, and confine our attention this morning, to those of liquids, or non-elastic fluids.

[Pg 119]

Water, and liquids in general, are scarcely susceptible of being compressed, or squeezed into a smaller space, than that which they naturally occupy. Such, however, is the extreme minuteness of their particles, that by strong compression, they sometimes force their way through the pores of the substance which confines them. This was shown by a celebrated experiment, made at Florence many years ago. A hollow globe of gold was filled with water, and on its being submitted to great pressure, the water was seen to exude through the pores of the gold, which it covered with a fine dew. Many philosophers, however, think that this experiment is too much relied upon, as it does not appear that it has ever been repeated; it is possible, therefore, that there may have been some source of error, which was not discovered by the experimenters. Fluids, appear to gravitate more freely, than solid bodies; for the strong cohesive attraction of the particles of the latter, in some measure counteracts the effect of gravity. In this table, for instance, the cohesion of the particles of wood, enables four slender legs to support a considerable weight. Were the cohesion destroyed, or, in other words, the wood converted into a fluid, no support could be afforded by the legs, for the particles no longer cohering together, each would press separately and independently, and would be brought to a level with the surface of the earth.

Emily. This want of cohesion is then the reason why fluids can never be formed into figures, or maintained in heaps; for though it is true the wind raises water into waves, they are immediately afterwards destroyed by gravity, and water always finds its level.

Mrs. B. Do you understand what is meant by the level, or equilibrium of fluids?

Emily. I believe I do, though I feel rather at a loss to explain it. Is not a fluid level when its surface is smooth and flat, as is the case with all fluids, when in a state of rest?

Mrs. B. Smooth, if you please, but not flat; for the definition of the equilibrium of a fluid is, that every part of the surface is equally distant from the point to which they gravitate, that is to say, from the centre of the earth; hence the surface of all fluids must be spherical, not flat, since they will partake of the spherical form of the globe. This is very evident in large bodies of water, such as the ocean, but the sphericity of small bodies of water, is so trifling, that their surfaces appear flat.

[Pg 120]

This level, or equilibrium of fluids, is the natural result of their particles gravitating independently of each other; for when any particle of a fluid, accidentally finds itself elevated above the rest, it is attracted down to the level of the surface of the fluid, and the readiness with which fluids yield to the slightest impression, will enable the particle by its weight, to penetrate the surface of the fluid, and mix with it.

Caroline. But I have seen a drop of oil, float on the surface of water, without mixing with it.

Mrs. B. They do not mix, because their particles repel each other, and the oil rises to the surface, because oil is a lighter liquid than water. If you were to pour water over it, the oil would still rise, being forced up by the superior gravity of the water. Here is an instrument called a spirit-level, ([fig. 1, plate 13.](#)) which is constructed upon the principle of the equilibrium of fluids. It consists of a short tube A B, closed at both ends, and containing a little water, or more commonly some spirits: it is so nearly filled, as to leave only a small bubble of air; when the tube is perfectly horizontal, this bubble will occupy the middle of it, but when not perfectly horizontal, the water runs to the lower, and the bubble of air or spirit rises to the upper end; by this instrument, the level of any situation, to which we apply it, may be ascertained.

From the strong cohesion of their particles, you may therefore consider solid bodies as gravitating in masses, while every particle of a fluid may be considered as separate, and gravitating independently of each other. Hence the resistance of a fluid, is considerably less, than that of a solid body; for the resistance of the particles, acting separately, is more easily overcome.

Emily. A body of water, in falling, does certainly less injury than a solid body of the same weight.

Mrs. B. The particles of fluids, acting thus independently, press against each other in every direction, not only downwards, but upwards, and laterally or sideways; and in consequence of this equality of pressure, every particle remains at rest, in the fluid. If you agitate the fluid, you

PLATE XIII.

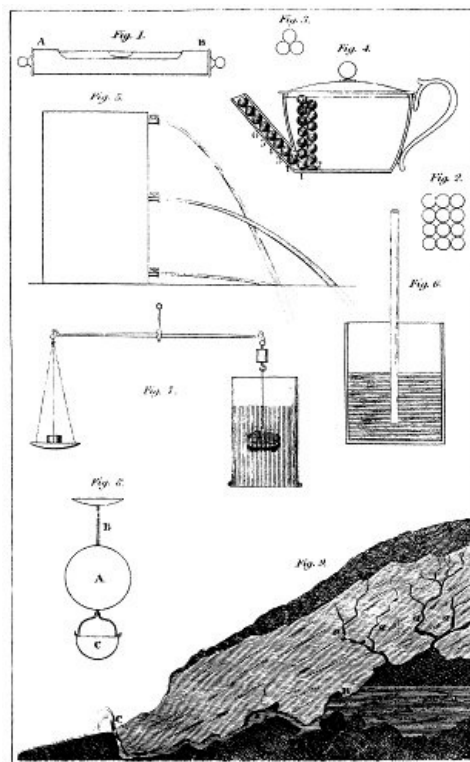

Caroline. The pressure downwards is very natural; it is the effect of gravity; one particle, weighing upon another, presses on it; but the pressure sideways, and particularly the pressure upwards, I cannot understand.

Mrs. B. If there were no lateral pressure, water would not run out of an opening on the side of a vessel. If you fill a vessel with sand, it will not continue to run out of such an opening, because there is scarcely any lateral pressure among its particles.

Emily. When water runs out of the side of a vessel, is it not owing to the weight of the water, above the opening?

Mrs. B. If the particles of fluids were arranged in regular columns, thus, (fig. 2.) there would be no lateral pressure, for when one particle is perpendicularly above the other, it can only press downwards; but as it must continually happen, that a particle presses between two particles beneath, (fig. 3.) these last, must suffer a lateral pressure.

Emily. The same as when a wedge is driven into a piece of wood, and separates the parts, laterally.

Mrs. B. Yes. The lateral pressure proceeds, therefore, entirely from the pressure downwards, or the weight of the liquid above; and consequently, the lower the orifice is made in the vessel, the greater will be the velocity of the water rushing out of it. Here is a vessel of water (fig. 5.), with three stop cocks at different heights; we shall open them, and you will see with what different degrees of velocity, the water issues from them. Do you understand this, Caroline?

Caroline. Oh yes. The water from the upper spout, receiving but a slight pressure, on account of its vicinity to the surface, flows but gently; the second cock, having a greater weight above it, the water is forced out with greater velocity, whilst the lowest cock, being near the bottom of the vessel, receives the pressure of almost the whole body of water, and rushes out with the greatest impetuosity.

Mrs. B. Very well; and you must observe, that as the lateral pressure, is entirely owing to the pressure downwards, it is not affected by the horizontal dimensions of the vessel, which contains the water, but merely by its depth; for as every particle acts independently of the rest, it is only the column of particles immediately above the orifice, that can weigh upon, and press out the water.

Emily. The breadth and width of the vessel then, can be of no consequence in this respect. The lateral pressure on one side, in a cubical vessel, is, I suppose, not so great as the pressure downwards upon the bottom.

[Pg 122]

Mrs. B. No; in a cubical vessel, the pressure downwards will be double the lateral pressure on one side; for every particle at the bottom of the vessel is pressed upon, by a column of the whole depth of the fluid, whilst the lateral pressure diminishes from the bottom upwards to the surface, where the particles have no pressure.

Caroline. And from whence proceeds the pressure of fluids upwards? that seems to me the most unaccountable, as it is in direct opposition to gravity.

Mrs. B. And yet it is in consequence of their pressure downwards. When, for example, you pour water into a tea-pot, the water rises in the spout, to a level with the water in the pot. The particles of water at the bottom of the pot, are pressed upon by the particles above them; to this pressure they will yield, if there is any mode of making way for the superior particles, and as they cannot descend, they will change their direction, and rise in the spout.

Suppose the tea-pot to be filled with columns of particles of water, similar to that described in [fig. 4.](#), the particle 1, at the bottom, will be pressed laterally by the particle 2, and by this pressure be forced into the spout, where, meeting with the particle 3, it presses it upwards, and this pressure will be continued from 3 to 4, from 4 to 5, and so on, till the water in the spout, has risen to a level with that in the pot.

Emily. If it were not for this pressure upwards, forcing the water to rise in the spout, the equilibrium of the fluid would be destroyed.

Caroline. True; but then a tea-pot is wide and large, and the weight of so great a body of water as the pot will contain, may easily force up and support so small a quantity, as will fill the spout. But would the same effect be produced, if the spout and the pot, were of equal dimensions?

Mrs. B. Undoubtedly it would. You may even reverse the experiment, by pouring water into the spout, and you will find that the water will rise in the pot, to a level with that in the spout; for the pressure of the small quantity of water in the spout, will force up and support, the larger quantity in the pot. In the pressure upwards, as well as that laterally, you see that the force of pressure, depends entirely on the height, and is quite independent of the horizontal dimensions of the fluid.

[Pg 123]

As a tea-pot is not transparent, let us try the experiment by filling this large glass goblet, by means of this narrow tube, ([fig. 6.](#))

Caroline. Look, Emily, as Mrs. B. fills it, how the water rises in the goblet, to maintain an equilibrium with that in the tube.

Now, Mrs. B., will you let me fill the tube, by pouring water into the goblet?

Mrs. B. That is impossible. However, you may try the experiment, and I doubt not that you will be able to account for its failure.

Caroline. It is very singular, that if so small a column of water as is contained in the tube, can force up and support the whole contents of the goblet; that the weight of all the water in the goblet, should not be able to force up the small quantity required to fill the tube:—oh, I see now the reason, the water in the goblet, cannot force that in the tube above its level, and as the end of the tube, is considerably higher than the goblet, it can never be filled by pouring water into the goblet.

Mrs. B. And if you continue to pour water into the goblet when it is full, the water will run over, instead of rising above its level in the tube.

I shall now explain to you the meaning of the *specific gravity* of bodies.

Caroline. What! is there another species of gravity, with which we are not yet acquainted?

Mrs. B. No: the specific gravity of a body, means simply its weight, compared with that of another body, of the same size. When we say, that substances, such as lead, and stones, are heavy, and that others, such as paper and feathers, are light, we speak comparatively; that is to say, that the first are heavy, and the latter light, in comparison with the generality of substances in nature. Would you call wood, and chalk, light or heavy bodies?

Caroline. Some kinds of wood are heavy, certainly, as oak and mahogany; others are light, as cedar and poplar.

Emily. I think I should call wood in general, a heavy body; for cedar and poplar, are light, only in comparison to wood of a heavier description. I am at a loss to determine whether chalk should be ranked as a heavy, or a light body; I should be inclined to say the former, if it was not that it is lighter than most other minerals. I perceive that we have but vague notions of light and heavy. I wish there was some standard of comparison, to which we could refer the weight of all other bodies.

[Pg 124]

Mrs. B. The necessity of such a standard, has been so much felt, that a body has been fixed upon for this purpose. What substance do you think would be best calculated to answer this end?

Caroline. It must be one generally known, and easily obtained; lead or iron, for instance.

Mrs. B. The metals, would not answer the purpose well, for several reasons; they are not always equally compact, and they are rarely quite pure; two pieces of iron, for instance, although of the same size, might not, from the causes mentioned, weigh exactly alike.

Caroline. But, Mrs. B., if you compare the weight, of equal quantities of different bodies, they will all be alike. You know the old saying, that a pound of feathers, is as heavy as a pound of lead?

Mrs. B. When therefore we compare the weight of different kinds of bodies, it would be absurd to take quantities of equal *weight*, we must take quantities of equal *bulk*; pints or quarts, not ounces or pounds.

Caroline. Very true; I perplexed myself by thinking that quantity referred to weight, rather than to measure. It is true, it would be as absurd to compare bodies of the same size, in order to ascertain which was largest, as to compare bodies of the same weight, in order to discover which was heaviest.

Mrs. B. In estimating the specific gravity of bodies, therefore, we must compare equal bulks, and we shall find that their specific gravity, will be proportional to their weights. The body which has been adopted as a standard of reference, is distilled, or rain water.

Emily. I am surprised that a fluid should have been chosen for this purpose, as it must necessarily be contained in some vessel, and the weight of the vessel, will require to be deducted.

Mrs. B. You will find that the comparison will be more easily made with a fluid, than with a solid; and water you know can be every where obtained. In order to learn the specific gravity of a solid body, it is not necessary to put a certain measure of it in one scale, and an equal measure of water into the other scale: but simply to weigh the body under trial, first in air, and then in water. If you weigh a piece of gold, in a glass of water, will not the gold displace just as much water, as is equal to its own bulk?

[Pg 125]

Caroline. Certainly, where one body is, another cannot be at the same time; so that a sufficient quantity of water must be removed, in order to make way for the gold.

Mrs. B. Yes, a cubic inch of water, to make room for a cubic inch of gold; remember that the bulk, alone, is to be considered; the weight, has nothing to do with the quantity of water displaced, for an inch of gold, does not occupy more space, and therefore will not displace more water, than an inch of ivory, or any other substance, that will sink in water.

Well, you will perhaps be surprised to hear that the gold will weigh less in water, than it did out of it?

Emily. And for what reason?

Mrs. B. On account of the upward pressure of the particles of water, which in some measure supports the gold, and by so doing, diminishes its weight. If the body immersed in water, was of the same weight as that fluid, it would be wholly supported by it, just as the water which it displaces, was supported, previous to its making way for the solid body. If the body is heavier than the water, it cannot be wholly supported by it; but the water will offer some resistance to its descent.

Caroline. And the resistance which water offers to the descent of heavy bodies immersed in it, (since it proceeds from the upward pressure of the particles of the fluid,) must in all cases, I suppose, be the same?

Mrs. B. Yes: the resistance of the fluid, is proportioned to the bulk, and not to the weight, of the body immersed in it; all bodies of the same size, therefore, lose the same quantity of their weight in water. Can you form any idea what this loss will be?

Emily. I should think it would be equal to the weight of the water displaced; for, since that portion of the water was supported before the immersion of the solid body, an equal weight of the solid body, will be supported.

Mrs. B. You are perfectly right; a body weighed in water, loses just as much of its weight, as is equal to that of the water it displaces; so that if you were to put the water displaced, into the scale to which the body is suspended, it would restore the balance.

You must observe, that when you weigh a body in water, in order to ascertain its specific gravity, you must not sink the dish of the balance in the water; but either suspend the body to a hook at the bottom of the dish, or else take off the dish, and suspend to the arm of the balance a weight to counterbalance the other dish, and to this attach the solid to be weighed, ([fig. 7.](#)) Now suppose that a cubic inch of gold, weighed 19 ounces out of water, and lost one ounce of its weight by being weighed in water, what would be its specific gravity?

[Pg 126]

Caroline. The cubic inch of water it displaced, must weigh that one ounce; and as a cubic inch of gold, weighs 19 ounces, gold is 19 times, as heavy as water.

Emily. I recollect having seen a table of the comparative weights of bodies, in which gold appeared to me to be estimated at 19 thousand times, the weight of water.

Mrs. B. You misunderstood the meaning of the table. In the estimation you allude to, the weight of water was reckoned at 1000. You must observe, that the weight of a substance when not compared to that of any other, is perfectly arbitrary; and when water is adopted as a standard, we may denominate its weight by any number we please; but then the weight of all bodies tried by this standard, must be signified by proportional numbers.

Caroline. We may call the weight of water, for example, one, and then that of gold, would be nineteen; or if we choose to call the weight of water 1000, that of gold would be 19,000. In short, specific gravity, means how many times more a body weighs, than an equal bulk of water.

Mrs. B. It is rather the weight of a body compared with a portion of water equal to it in bulk; for the specific gravity of many substances, is less than that of water.

Caroline. Then you cannot ascertain the specific gravity of such substances, in the same manner

as that of gold; for a body that is lighter than water, will float on its surface, without displacing any of it.

Mrs. B. If a body were absolutely without weight, it is true that it would not displace a drop of water, but the bodies we are treating of, have all some weight, however small; and will, therefore, displace some quantity. If the body be lighter than water, it will not sink to a level with its surface, and therefore it will not displace so much water as is equal to its bulk; but only so much, as is equal to its weight. A ship, you must have observed, sinks to some depth in water, and the heavier it is laden, the deeper it sinks, as it always displaces a quantity of water, equal to its own weight.

Caroline. But you said just now, that in the immersion of gold, the bulk, and not the weight of body, was to be considered. [Pg 127]

Mrs. B. That is the case with all substances which are heavier than water; but since those which are lighter, do not displace so much as their own bulk, the quantity they displace is not a test of their specific gravity.

In order to obtain the specific gravity of a body which is lighter than water, you must attach to it a heavy one, whose specific gravity is known, and immerse them together; the specific gravity of the lighter body, may then be easily calculated from observing the loss of weight it produces, in the heavy body.

Emily. But are there not some bodies which have exactly the same specific gravity as water?

Mrs. B. Undoubtedly; and such bodies will remain at rest in whatever situation they are placed in water. Here is a piece of wood which I have procured, because it is of a kind which is precisely the weight of an equal bulk of water; in whatever part of this vessel of water you place it, you will find that it will remain stationary.

Caroline. I shall first put it at the bottom; from thence, of course, it cannot rise, because it is not lighter than water. Now I shall place it in the middle of the vessel; it neither rises nor sinks, because it is neither lighter nor heavier than the water. Now I will lay it on the surface of the water; but there it sinks a little—what is the reason of that, Mrs. B.?

Mrs. B. Since it is not lighter than the water, it cannot float upon its surface; since it is not heavier than water, it cannot sink below its surface: it will sink therefore, only till the upper surface of both bodies are on a level, so that the piece of wood is just covered with water. If you poured a few drops of water into the vessel, (so gently as not to give them momentum) they would mix with the water at the surface, and not sink lower.

Caroline. I now understand the reason, why, in drawing up a bucket of water out of a well, the bucket feels so much heavier when it rises above the surface of the water in the well; for whilst you raise it in the water, the water within the bucket being of the same specific gravity as the water on the outside, will be wholly supported by the upward pressure of the water beneath the bucket, and consequently very little force will be required to raise it; but as soon as the bucket rises to the surface of the well, you immediately perceive the increase of weight.

Emily. And how do you ascertain the specific gravity of fluids? [Pg 128]

Mrs. B. By means of an hydrometer; this instrument is made of various materials, and in different forms, one of which I will show you. It consists of a thin brass ball A, ([fig. 8, plate 13.](#)) with a graduated tube B, and the specific gravity of the liquid, is estimated by the depth to which the instrument sinks in it, or by the weight required to sink it to a given depth. There is a small bucket C, suspended at the lower end, and also a little dish on the graduated tube; into either of these, small weights may be put, until the instrument sinks in the fluid, to a mark on the tube B; the amount of weight necessary for this, will enable you to discover the specific gravity of the fluid.

I must now take leave of you; but there remain yet many observations to be made on fluids: we shall, therefore, resume this subject at our next interview.

Questions

1. (Pg. [118](#)) What are the two divisions of the science which treats of the mechanical properties of liquids?
2. (Pg. [118](#)) Of what do hydrostatics and hydraulics treat?
3. (Pg. [118](#)) What is a fluid defined to be?
4. (Pg. [118](#)) From what is fluidity supposed to arise?
5. (Pg. [118](#)) Into what two classes are fluids divided?
6. (Pg. [119](#)) What is said of the incompressibility of liquids, and what experiment is related?
7. (Pg. [119](#)) Ought this experiment to be considered as conclusive?
8. (Pg. [119](#)) Why do fluids appear to gravitate more freely than solids?
9. (Pg. [120](#)) When is a fluid said to be in equilibrium?
10. (Pg. [120](#)) What is there in the nature of a fluid, which causes it to seek this level?
11. (Pg. [120](#)) What circumstances occasion oil to float upon water?
12. (Pg. [120](#)) What is the nature and use of the instrument represented in [fig. 1, plate 13](#)?
13. (Pg. [120](#)) What difference is there in the gravitation of solid masses, and of fluids?
14. (Pg. [121](#)) What results as regards the pressure of fluids?
15. (Pg. [121](#)) How is this illustrated by [fig. 2, 3, plate 13](#)?
16. (Pg. [121](#)) From what does the lateral pressure proceed? and to what is it proportioned,

- as exemplified in [fig. 5, plate 13](#)?
17. (Pg. [122](#)) Has the extent of the surface of a fluid, any effect upon its pressure downwards?
 18. (Pg. [122](#)) What will be the difference between the pressure upon the bottom, and upon one side of a cubical vessel?
 19. (Pg. [122](#)) What occasions the upward pressure, and how is it explained by [fig. 4, plate 13](#)?
 20. (Pg. [123](#)) How could the equilibrium of fluids be exemplified by pouring water in at the spout of a tea-pot?
 21. (Pg. [123](#)) How by the apparatus represented at [fig. 6, plate 13](#)?
 22. (Pg. [123](#)) What is meant by the specific gravity of a body?
 23. (Pg. [123](#)) What do we in common mean by calling a body heavy, or light?
 24. (Pg. [124](#)) Why would not the metals answer to compare other bodies with?
 25. (Pg. [124](#)) What must be supposed equal in estimating the specific gravity of a body?
 26. (Pg. [124](#)) What has been adopted as a standard for comparison?
 27. (Pg. [125](#)) What is the first step in ascertaining the specific gravity of a solid?
 28. (Pg. [125](#)) What quantity of water will the solid displace?
 29. (Pg. [125](#)) Why will a solid weigh less in water than in air, and to what will the loss of weight be equal?
 30. (Pg. [126](#)) What is the arrangement represented by [fig. 7, plate 13](#)?
 31. (Pg. [126](#)) What is stated of gold as an example?
 32. (Pg. [126](#)) In comparing a body with water, this is sometimes called 1000, what must be observed?
 33. (Pg. [126](#)) What quantity of water is displaced, by a body floating upon its surface?
 34. (Pg. [127](#)) How can you find the specific gravity of a solid which is lighter than water?
 35. (Pg. [127](#)) What is observed of a body whose specific gravity is the same as that of water?
 36. (Pg. [127](#)) What is the reason that in drawing a bucket of water from a well, its weight is not perceived until it rises above the surface?
 37. (Pg. [128](#)) Describe the instrument represented by [fig. 8, plate 13](#), and also how, and for what it is used?

CONVERSATION XI. OF SPRINGS, FOUNTAINS, &c.

OF THE ASCENT OF VAPOUR AND THE FORMATION OF CLOUDS. OF THE FORMATION AND FALL OF RAIN, &c. OF THE FORMATION OF SPRINGS. OF RIVERS AND LAKES. OF FOUNTAINS.

CAROLINE.

There is a question I am very desirous of asking you, respecting fluids, Mrs. B., which has often perplexed me. What is the reason that the great quantity of rain which falls upon the earth and sinks into it, does not, in the course of time, injure its solidity? The sun and the wind, I know, dry the surface, but they have no effect on the interior parts, where there must be a prodigious accumulation of moisture.

Mrs. B. Do you not know, that, in the course of time, all the water which sinks into the ground, rises out of it again? It is the same water which successively forms seas, rivers, springs, clouds, rain, and sometimes hail, snow and ice. If you will take the trouble of following it through these various changes, you will understand why the earth is not yet drowned, by the quantity of water which has fallen upon it, since its creation; and you will even be convinced, that it does not contain a single drop more water now, than it did at that period.

[Pg 129]

Let us consider how the clouds were originally formed. When the first rays of the sun warmed the surface of the earth, the heat, by separating the particles of water, rendered them lighter than the air. This, you know, is the case with steam or vapour. What then ensues?

Caroline. When lighter than the air, it will naturally rise; and now I recollect your telling us in a preceding lesson, that the heat of the sun transformed the particles of water into vapour; in consequence of which, it ascended into the atmosphere, where it formed clouds.

Mrs. B. We have then already followed water through two of its transformations; from water it becomes vapour, and from vapour clouds.

Emily. But since this watery vapour is lighter than the air, why does it not continue to rise; and why does it unite again, to form clouds?

Mrs. B. Because the atmosphere diminishes in density, as it is more distant from the earth. The vapour, therefore, which the sun causes to exhale, not only from seas, rivers, and lakes, but likewise from the moisture on the land, rises till it reaches a region of air of its own specific gravity; and there, you know, it will remain stationary. By the frequent accession of fresh vapour, it gradually accumulates, so as to form those large bodies of vapour, which we call clouds: and the particles, at length uniting, become too heavy for the air to support, and fall to the ground.

Caroline. They do fall to the ground, certainly, when it rains; but, according to your theory, I

should have imagined, that when the clouds became too heavy, for the region of air in which they were situated, to support them, they would descend, till they reached a stratum of air of their own weight, and not fall to the earth; for as clouds are formed of vapour, they cannot be so heavy as the lowest regions of the atmosphere, otherwise the vapour would not have risen.

Mrs. B. If you examine the manner in which the clouds descend, it will obviate this objection. In falling, several of the watery particles come within the sphere of each other's attraction, and unite in the form of a drop of water. The vapour thus transformed into a shower, is heavier than any part of the atmosphere, and consequently descends to the earth.

[Pg 130]

Caroline. How wonderfully curious!

Mrs. B. It is impossible to consider any part of nature attentively, without being struck with admiration at the wisdom it displays; and I hope you will never contemplate these wonders, without feeling your heart glow with admiration and gratitude, towards their bounteous Author. Observe, that if the waters were never drawn out of the earth, all vegetation would be destroyed by the excess of moisture; if, on the other hand, the plants were not nourished and refreshed by occasional showers, the drought would be equally fatal to them. If the clouds constantly remained in a state of vapour, they might, as you remarked, descend into a heavier stratum of the atmosphere, but could never fall to the ground; or were the power of attraction more than sufficient to convert the vapour into drops, it would transform the cloud into a mass of water, which, instead of nourishing, would destroy the produce of the earth.

Water then ascends in the form of vapour, and descends in that of rain, snow, or hail, all of which ultimately become water. Some of this falls into the various bodies of water on the surface of the globe, the remainder upon the land. Of the latter, part reascends in the form of vapour, part is absorbed by the roots of vegetables, and part descends into the earth, where it forms springs.

Emily. Is there then no difference between rain water, and spring water?

Mrs. B. They are originally the same; but that portion of rain water which goes to supply springs, dissolves a number of foreign particles, which it meets with in its passage through the various soils it traverses.

Caroline. Yet spring water is more pleasant to the taste, appears more transparent, and, I should have supposed, would have been more pure than rain water.

Mrs. B. No; excepting distilled water, rain water is the most pure we can obtain; it is its purity which renders it insipid; whilst the various salts and different ingredients, dissolved in spring water, give it a species of flavour, which habit renders agreeable; these salts do not, in any degree, affect its transparency; and the filtration it undergoes, through gravel and sand, cleanses it from all foreign matter, which it has not the power of dissolving.

[Pg 131]

Emily. How is it that the rain water does not continue to descend by its gravity, instead of collecting together, and forming springs?

Mrs. B. When rain falls on the surface of the earth, it continues making its way downwards through the pores and crevices in the ground. When several drops meet in their subterraneous passage, they unite and form a little rivulet; this, in its progress, meets with other rivulets of a similar description, and they pursue their course together within the earth, till they are stopped by some substance, such as rock, or clay, which they cannot penetrate.

Caroline. But you say that there is some reason to believe that water can penetrate even the pores of gold, and it cannot meet with a substance more dense?

Mrs. B. But if water penetrate the pores of gold, it is only when under a strong compressive force, as in the Florentine experiment; now in its passage towards the centre of the earth, it is acted upon by no other power than gravity, which is not sufficient to make it force its way, even through a stratum of clay. This species of earth, though not remarkably dense, being of great tenacity, will not admit the particles of water to pass. When water encounters any substance of this nature, therefore, its progress is stopped, and it is diffused through the porous earth, and sometimes the pressure of the accumulating waters, forms a bed, or reservoir. This will be more clearly explained by [fig. 9, plate 13](#), which represents a section, of the interior of a hill or mountain. A, is a body of water, such as I have described, which, when filled up as high as B, (by the continual accession of water it receives from the ducts or rivulets *a, a, a, a,*) finds a passage out of the cavity, and, impelled by gravity, it runs on, till it makes its way out of the ground at the side of the hill, and there forms a spring, C.

Caroline. Gravity impels downwards towards the centre of the earth; and the spring in this figure runs in an horizontal direction.

Mrs. B. Not entirely. There is some declivity from the reservoir, to the spot where the water issues out of the ground; and gravity, you know, will bring bodies down an inclined plane, as well as in a perpendicular direction.

Caroline. But though the spring may descend, on first issuing, it must afterwards rise to reach the surface of the earth; and that is in direct opposition to gravity.

Mrs. B. A spring can never rise above the level of the reservoir whence it issues; it must, therefore, find a passage to some part of the surface of the earth, that is lower, or nearer the

[Pg 132]

centre, than the reservoir. It is true that, in this figure, the spring rises in its passage from B to C; but this, I think, with a little reflection, you will be able to account for.

Emily. Oh, yes; it is owing to the pressure of fluids upwards; and the water rises in the duct, upon the same principle as it rises in the spout of a tea-pot; that is to say, in order to preserve an equilibrium with the water in the reservoir. Now I think I understand the nature of springs: the water will flow through a duct, whether ascending or descending, provided it never rises higher than the reservoir.

Mrs. B. Water may thus be conveyed to every part of a town, and to the upper part of the houses, if it is originally brought from a height, superior to any to which it is conveyed. Have you never observed, when the pavements of the streets have been mending, the pipes which serve as ducts for the conveyance of the water through the town?

Emily. Yes, frequently; and I have remarked that when any of these pipes have been opened, the water rushes upwards from them, with great velocity; which, I suppose, proceeds from the pressure of the water in the reservoir, which forces it out.

Caroline. I recollect having once seen a very curious glass, called Tantalus's cup; it consists of a goblet, containing a small figure of a man, and whatever quantity of water you pour into the goblet, it never rises higher than the breast of the figure. Do you know how that is contrived?

Mrs. B. It is by means of a syphon, or bent tube, which is concealed in the body of the figure. This tube rises through one of the legs, as high as the breast, and there turning, descends through the other leg, and from thence through the foot of the goblet, where the water runs out. (fig. 1, plate 14.) When you pour water into the glass A, it must rise in the syphon B, in proportion as it rises in the glass; and when the glass is filled to a level with the upper part of the syphon, the water will run out through the other leg of the figure, and will continue running out, as fast as you pour it in; therefore the glass can never fill any higher.

Emily. I think the new well that has been made at our country-house, must be of that nature. We had a great scarcity of water, and my father has been at considerable expense to dig a well; after penetrating to a great depth, before water could be found, a spring was at length discovered, but the water rose only a few feet above the bottom of the well; and sometimes it is quite dry.

[Pg 133]

PLATE XIV.

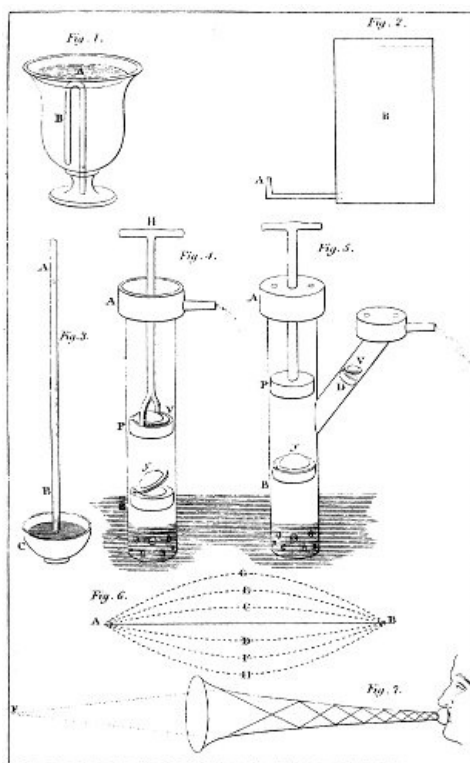

Mrs. B. This has, however, no analogy to Tantalus's cup; but is owing to the very elevated situation of your country-house.

Emily. I believe I guess the reason. There cannot be a reservoir of water near the summit of a hill; as in such a situation, there will not be a sufficient number of rivulets formed, to supply one; and without a reservoir, there can be no spring. In such situations, therefore, it is necessary to dig very deep, in order to meet with a spring; and when we give it vent, it can rise only as high as the reservoir from whence it flows, which will be but little, as the reservoir must be situated at some considerable depth below the summit of the hill.

Caroline. Your explanation appears very clear and satisfactory; but I can contradict it from experience. At the very top of a hill, near our country-house, there is a large pond, and, according to your theory, it would be impossible there should be springs in such a situation to supply it with water. Then you know that I have crossed the Alps, and I can assure you, that there is a fine lake on the summit of Mount Cenis, the highest mountain we passed over.

Mrs. B. Were there a lake on the summit of Mount Blanc, which is the highest of the Alps, it would indeed be wonderful. But that on Mount Cenis, is not at all contradictory to our theory of springs; for this mountain is surrounded by others, much more elevated, and the springs which feed the lake must descend from reservoirs of water, formed in those mountains. This must also be the case with the pond on the top of the hill; there is doubtless some more considerable hill in the neighbourhood, which supplies it with water.

Emily. I comprehend perfectly, why the water in our well never rises high: but I do not understand why it should occasionally be dry.

Mrs. B. Because the reservoir from which it flows, being in an elevated situation, is but scantily supplied with water; after a long drought, therefore, it may be drained, and the spring dry, till the reservoir be replenished by fresh rains. It is not uncommon to see springs flow with great violence in wet seasons, which at other times, are perfectly dry.

Caroline. But there is a spring in our grounds, which more frequently flows in dry, than in wet weather; how is that to be accounted for? [Pg 134]

Mrs. B. The spring, probably, comes from a reservoir at a great distance, and situated very deep in the ground: it is, therefore, some length of time before the rain reaches the reservoir; and another considerable portion must elapse, whilst the water is making its way, from the reservoir, to the surface of the earth; so that the dry weather may probably have succeeded the rains, before the spring begins to flow; and the reservoir may be exhausted, by the time the wet weather sets in again.

Caroline. I doubt not but this is the case, as the spring is in a very low situation, therefore, the reservoir may be at a great distance from it.

Mrs. B. Springs which do not constantly flow, are called intermitting, and are occasioned by the reservoir being imperfectly supplied. Independently of the situation, this is always the case, when the duct, or ducts, which convey the water into the reservoir, are smaller than those which carry it off.

Caroline. If it runs out, faster than it runs in, it will of course sometimes be empty. Do not rivers also, derive their source from springs?

Mrs. B. Yes, they generally take their source in mountainous countries, where springs are most abundant.

Caroline. I understood you that springs were more rare, in elevated situations.

Mrs. B. You do not consider that mountainous countries, abound equally with high, and low situations. Reservoirs of water, which are formed in the bosoms of mountains, generally find a vent, either on their declivity, or in the valley beneath; while subterraneous reservoirs, formed in a plain, can seldom find a passage to the surface of the earth, but remain concealed, unless discovered by digging a well. When a spring once issues at the surface of the earth, it continues its course externally, seeking always a lower ground, for it can no longer rise.

Emily. Then what is the consequence, if the spring, or, as I should now rather call it, the rivulet, runs into a situation, which is surrounded by higher ground?

Mrs. B. Its course is stopped; the water accumulates, and it forms a pool, pond, or lake, according to the dimensions of the body of water. The lake of Geneva, in all probability, owes its origin to the Rhone, which passes through it: if, when the river first entered the valley, which now forms the bed of the Lake, it found itself surrounded by higher grounds, its waters would there accumulate, till they rose to a level with that part of the valley, where the Rhone now continues its course beyond the Lake, and from whence it flows through valleys, occasionally forming other small lakes, till it reaches the sea. [Pg 135]

Emily. And are not fountains, of the nature of springs?

Mrs. B. Exactly. A fountain is conducted perpendicularly upwards, by the spout or adjutage A, through which it flows; and it will rise nearly as high as the reservoir B, from whence it proceeds. ([Plate 14. fig. 2.](#))

Caroline. Why not quite as high?

Mrs. B. Because it meets with resistance from the air, in its ascent; and its motion is impeded by friction against the spout, where it rushes out.

Emily. But if the tube through which the water rises be smooth, can there be any friction? especially with a fluid, whose particles yield to the slightest impression.

Mrs. B. Friction, (as we observed in a former lesson,) may be diminished by polishing, but can never be entirely destroyed; and though fluids, are less susceptible of friction, than solid bodies, they are still affected by it. Another reason why a fountain will not rise so high as its reservoir, is, that as all the water which spouts up, has to descend again, it in doing so, presses, or strikes against the under parts, and forces them sideways, spreading the column into a head, and rendering it both wider, and shorter, than it otherwise would be.

At our next meeting, we shall examine the mechanical properties of the air, which being an elastic fluid, differs in many respects, from liquids.

Questions

1. (Pg. [129](#)) Why do not the frequent rains, fill the earth with water?
2. (Pg. [129](#)) Why will vapour rise? to what height will it ascend, and what will it form?
3. (Pg. [129](#)) How may drops of rain be formed?
4. (Pg. [130](#)) What becomes of the water after it has fallen to the earth?
5. (Pg. [130](#)) What is the difference between rain water, and that from springs?
6. (Pg. [130](#)) Why is rain more pure than spring water?
7. (Pg. [130](#)) Why is spring water more agreeable to the palate?
8. (Pg. [131](#)) What causes the water to collect and form springs?
9. (Pg. [131](#)) Why cannot water penetrate through clay?
10. (Pg. [131](#)) What is represented by [fig. 9, plate 13](#)?
11. (Pg. [132](#)) How can you account for its rising upwards, as represented at C?
12. (Pg. [132](#)) In conveying water by means of pipes, how must the reservoir be situated?
13. (Pg. [132](#)) What is the instrument called, which is represented in [plate 14, fig. 1](#),—and how does it operate?
14. (Pg. [133](#)) Why are wells rarely well supplied with water, in elevated situations?
15. (Pg. [133](#)) When water is found in elevated situations, whence is it supplied?
16. (Pg. [133](#)) Wells and springs, at some periods well supplied, fail at others; how is this accounted for?
17. (Pg. [134](#)) Some springs flow abundantly in dry weather, which occasionally fail in wet weather, how may this be explained?
18. (Pg. [134](#)) What is meant by intermitting springs?
19. (Pg. [134](#)) Whence do rivers, in general, derive their water?
20. (Pg. [134](#)) Why do springs abound more in mountainous, than in level countries?
21. (Pg. [135](#)) How are lakes formed?
22. (Pg. [135](#)) What causes water to rise in fountains, and how is this explained by [figure 2, plate 14](#)?
23. (Pg. [135](#)) Why will not the fountain rise to the height of the water in the reservoir?

CONVERSATION XII. ON THE MECHANICAL PROPERTIES OF AIR.

[Pg 136]

OF THE SPRING OR ELASTICITY OF THE AIR. OF THE WEIGHT OF THE AIR. EXPERIMENTS WITH THE AIR PUMP. OF THE BAROMETER. MODE OF WEIGHING AIR. SPECIFIC GRAVITY OF AIR. OF PUMPS. DESCRIPTION OF THE SUCKING PUMP. DESCRIPTION OF THE FORCING PUMP.

MRS. B.

At our last meeting we examined the properties of fluids in general, and more particularly of such as are called non-elastic fluids, or liquids.

There is another class of fluids, distinguished by the name of æriform, or elastic fluids, the principal of which is the air we breathe, which surrounds the earth, and is called the atmosphere.

Emily. There are then other kinds of air, besides the atmosphere?

Mrs. B. Yes; a great variety; but they differ only in their chemical, and not in their mechanical properties; and as it is the latter we are to examine, we shall not at present inquire into their composition, but confine our attention to the mechanical properties of elastic fluids in general.

Caroline. And from whence arises this difference, between elastic, and non-elastic fluids?

Mrs. B. There is no attraction of cohesion, between the particles of elastic fluids; so that the expansive power of heat, has no adversary to contend with, but gravity; any increase of temperature, therefore, expands elastic fluids considerably, and a diminution, proportionally condenses them.

The most essential point, in which air, differs from other fluids is in its spring or elasticity; that is to say, its power of increasing, or diminishing in bulk, accordingly as it is more, or less, compressed: a power of which I have informed you, liquids are almost wholly deprived.

Emily. I think I understand the elasticity of the air very well from what you formerly said of it; but what perplexes me is, its having gravity; if it is heavy, and we are surrounded by it, why do we not feel its weight?

[Pg 137]

Caroline. It must be impossible to be sensible of the weight of such infinitely small particles, as those of which the air is composed: particles which are too small to be seen, must be too light to be felt.

Mrs. B. You are mistaken, my dear; the air is much heavier than you imagine; it is true, that the particles which compose it, are small; but then, reflect on their quantity: the atmosphere extends in height, a great number of miles from the earth, and its gravity is such, that a man of middling

stature, is computed (when the air is heaviest) to sustain the weight of about 14 tons.

Caroline. Is it possible! I should have thought such a weight would have crushed any one to atoms.

Mrs. B. That would, indeed, be the case, if it were not for the equality of the pressure, on every part of the body; but when thus diffused, we can bear even a much greater weight, without any considerable inconvenience. In bathing we support the weight and pressure of the water, in addition to that of the atmosphere; but because this pressure is equally distributed over the body, we are scarcely sensible of it; whilst if your shoulders, your head, or any particular part of your frame, were loaded with the additional weight of a hundred pounds, you would soon sink under the fatigue. Besides this, our bodies contain air, the spring of which, counterbalances the weight of the external air, and renders us insensible of its pressure.

Caroline. But if it were possible to relieve me from the weight of the atmosphere, should I not feel more light and agile?

Mrs. B. On the contrary, the air within you, meeting with no external pressure to restrain its elasticity, would distend your body, and at length bursting some of the parts which confined it, put a period to your existence.

Caroline. This weight of the atmosphere, then, which I was so apprehensive would crush me, is, in reality, essential to my preservation.

Emily. I once saw a person cupped, and was told that the swelling of the part under the cup, was produced by taking away from that part, the pressure of the atmosphere; but I could not understand how this pressure produced such an effect.

Mrs. B. The air pump affords us the means of making a great variety of interesting experiments, on the weight, and pressure of the air: some of them you have already seen. Do you not recollect, that in a vacuum produced within the air pump, substances of various weights, fell to the bottom in the same time; why does not this happen in the atmosphere?

[Pg 138]

Caroline. I remember you told us it was owing to the resistance which light bodies meet with, from the air, during their fall.

Mrs. B. Or, in other words, to the support which they received from the air, and which prolonged the time of their fall. Now, if the air were destitute of weight, how could it support other bodies, or retard their fall?

I shall now show you some other experiments, which illustrate, in a striking manner, both the weight, and elasticity of air. I shall tie a piece of bladder over this glass receiver, which, you will observe, is open at the top as well as below.

Caroline. Why do you wet the bladder first?

Mrs. B. It expands by wetting, and contracts in drying; it is also more soft and pliable when wet, so that I can make it fit better, and when dry, it will be tighter. We must hold it to the fire in order to dry it; but not too near, lest it should burst by sudden contraction. Let us now fix it on the air pump, and exhaust the air from underneath it—you will not be alarmed if you hear a noise?

Emily. It was as loud as the report of a gun, and the bladder is burst! Pray explain how the air is concerned in this experiment.

Mrs. B. It is the effect of the weight of the atmosphere, on the upper surface of the bladder, when I had taken away the air from the under surface, so that there was no longer any reaction to counterbalance the pressure of the atmosphere, on the receiver. You observed how the bladder was pressed inwards, by the weight of the external air, in proportion as I exhausted the receiver: and before a complete vacuum was formed, the bladder, unable to sustain the violence of the pressure, burst with the explosion you have just heard.

I shall now show you an experiment, which proves the expansion of the air, contained within a body, when it is relieved from the pressure of the external air. You would not imagine that there was any air contained within this shrivelled apple, by its appearance; but take notice of it when placed within a receiver, from which I shall exhaust the air.

Caroline. How strange! it grows quite plump, and looks like a fresh-gathered apple.

Mrs. B. But as soon as I let the air again into the receiver, the apple, you see, returns to its shrivelled state. When I took away the pressure of the atmosphere, the air within the apple, expanded, and swelled it out; but the instant the atmospheric air was restored, the expansion of the internal air, was checked and repressed, and the apple shrunk to its former dimensions.

[Pg 139]

You may make a similar experiment with this little bladder, which you see is perfectly flaccid, and appears to contain no air: in this state I shall tie up the neck of the bladder, so that whatever air remains within it, may not escape, and then place it under the receiver. Now observe, as I exhaust the receiver, how the bladder distends; this proceeds from the great dilatation of the small quantity of air, which was enclosed within the bladder, when I tied it up; but as soon as I let the air into the receiver, that which the bladder contains, condenses and shrinks into its small compass, within the folds of the bladder.

Emily. These experiments are extremely amusing, and they afford clear proofs, both of the weight, and elasticity of the air; but I should like to know, exactly, how much the air weighs.

Mrs. B. A column of air reaching to the top of the atmosphere, and whose base is a square inch, weighs about 15 lbs. therefore, every square inch of our bodies, sustains a weight of 15 lbs.: and if you wish to know the weight of the whole of the atmosphere, you must reckon how many square inches there are on the surface of the globe, and multiply them by 15.

Emily. But can we not ascertain the weight of a small quantity of air?

Mrs. B. With perfect ease. I shall exhaust the air from this little bottle, by means of the air pump: and having emptied the bottle of air, or, in other words, produced a vacuum within it, I secure it by turning this screw adapted to its neck: we may now find the exact weight of this bottle, by putting it into one of the scales of a balance. It weighs, you see, just two ounces; but when I turn the screw, so as to admit the air into the bottle, the scale which contains it, preponderates.

Caroline. No doubt the bottle filled with air, is heavier than the bottle void of air; and the additional weight required to bring the scales again to a balance, must be exactly that of the air which the bottle now contains.

Mrs. B. That weight, you see, is almost two grains. The dimensions of this bottle, are six cubic inches. Six cubic inches of air, therefore, at the temperature of this room, weighs nearly 2 grains.

Caroline. Why do you observe the temperature of the room, in estimating the weight of the air? [Pg 140]

Mrs. B. Because heat rarefies air, and renders it lighter; therefore the warmer the air is, which you weigh, the lighter it will be.

If you should now be desirous of knowing the specific gravity of this air, we need only fill the same bottle, with water, and thus obtain the weight of an equal quantity of water—which you see is 1515 grs.; now by comparing the weight of water, to that of air, we find it to be in the proportion of about 800 to 1.

As you are acquainted with decimal arithmetic, you will understand what I mean, when I tell you, that water being called 1000, the specific gravity of air, will be 1.2.

I will show you another instance, of the weight of the atmosphere, which I think will please you: you know what a barometer is?

Caroline. It is an instrument which indicates the state of the weather, by means of a tube of quicksilver; but how, I cannot exactly say.

Mrs. B. It is by showing the weight of the atmosphere, which has great influence on the weather. The barometer, is an instrument extremely simple in its construction. In order that you may understand it, I will show you how it is made. I first fill with mercury, a glass tube A B, ([fig. 3. plate 14.](#)) about three feet in length, and open only at one end; then stopping the open end, with my finger, I immerse it in a cup C, containing a little mercury.

Emily. Part of the mercury which was in the tube, I observe, runs down into the cup; but why does not the whole of it subside, for it is contrary to the law of the equilibrium of fluids, that the mercury in the tube, should not descend to a level with that in the cup?

Mrs. B. The mercury that has fallen from the tube, into the cup, has left a vacant space in the upper part of the tube, to which the air cannot gain access; this space is therefore a perfect vacuum; the mercury in the tube, is relieved from the pressure of the atmosphere, whilst that in the cup, remains exposed to it.

Caroline. Oh, now I understand it; the pressure of the air on the mercury in the cup, forces it to rise in the tube, where there is not any air to counteract the external pressure.

Emily. Or rather supports the mercury in the tube, and prevents it from falling. [Pg 141]

Mrs. B. That comes to the same thing; for the power that can support mercury in a vacuum, would also make it ascend, when it met with a vacuum.

Thus you see, that the equilibrium of the mercury is destroyed, only to preserve the general equilibrium of fluids.

Caroline. But this simple apparatus is, in appearance, very unlike a barometer.

Mrs. B. It is all that is essential to a barometer. The tube and the cup, or a cistern of mercury, are fixed on a board, for the convenience of suspending it; the brass plate on the upper part of the board, is graduated into inches, and tenths of inches, for the purpose of ascertaining the height at which the mercury stands in the tube; and the small moveable metal plate, serves to show that height, with greater accuracy.

Emily. And at what height, will the weight of the atmosphere sustain the mercury?

Mrs. B. About 28 or 29 inches, as you will see by this barometer; but it depends upon the weight of the atmosphere, which varies much, in different states of the weather. The greater the pressure of the air on the mercury in the cup, the higher it will ascend in the tube. Now can you tell me whether the air is heavier, in wet, or in dry weather?

Caroline. Without a moment's reflection, the air must be heaviest in wet weather. It is so depressing, and makes one feel so heavy, while in fine weather, I feel as light as a feather, and as brisk as a bee.

Mrs. B. Would it not have been better to have answered with a moment's reflection, Caroline? It would have convinced you, that the air must be heaviest in dry weather; for it is then, that the mercury is found to rise in the tube, and consequently, the mercury in the cup, must be most pressed by the air.

Caroline. Why then does the air feel so heavy, in bad weather?

Mrs. B. Because it is less salubrious, when impregnated with damp. The lungs, under these circumstances, do not play so freely, nor does the blood circulate so well; thus obstructions are frequently occasioned in the smaller vessels, from which arise colds, asthmas, agues, fevers, &c.

Emily. Since the atmosphere diminishes in density, in the upper regions, is not the air more rare, upon a hill, than in a plain; and does the barometer indicate this difference?

Mrs. B. Certainly. This instrument, is so exact in its indications, that it is used for the purpose of measuring the height of mountains, and of estimating the elevation of balloons; the mercury descending in the tube, as you ascend to a greater height. [Pg 142]

Emily. And is no inconvenience experienced, from the thinness of the air, in such elevated situations?

Mrs. B. Oh, yes; frequently. It is sometimes oppressive, from being insufficient for respiration; and the expansion which takes place, in the more dense air contained within the body, is often painful: it occasions distention, and sometimes causes the bursting of the smaller blood-vessels, in the nose, and ears. Besides in such situations, you are more exposed, both to heat, and cold; for though the atmosphere is itself transparent, its lower regions, abound with vapours, and exhalations, from the earth, which float in it, and act in some degree as a covering, which preserves us equally from the intensity of the sun's rays, and from the severity of the cold.

Caroline. Pray, Mrs. B., is not the thermometer constructed on the same principles as the barometer?

Mrs. B. Not at all. The rise and fall of the fluid in the thermometer, is occasioned by the expansive power of heat, and the condensation produced by cold: the air has no access to it. An explanation of it would, therefore, be irrelevant to our present subject.

Emily. I have been reflecting, that since it is the weight of the atmosphere, which supports the mercury, in the tube of a barometer, it would support a column of any other fluid, in the same manner.

Mrs. B. Certainly; but as mercury, is heavier than all other fluids, it will support a higher column, of any other fluid; for two fluids are in equilibrium, when their height varies, inversely as their densities. We find the weight of the atmosphere, is equal to sustaining a column of water, for instance, of no less than 32 feet above its level.

Caroline. The weight of the atmosphere, is then, as great as that of a body of water of 32 feet in height.

Mrs. B. Precisely; for a column of air, of the height of the atmosphere, is equal to a column of water of about 32 feet, or one of mercury, of from 28 to 29 inches.

The common pump, is dependent on this principle. By the act of pumping, the pressure of the atmosphere is taken off the water, which, in consequence, rises. [Pg 143]

The body of a pump, consists of a large tube or pipe, whose lower end is immersed in the water which it is designed to raise. A kind of stopper, called a piston, is fitted to this tube, and is made to slide up and down it, by means of a metallic rod, fastened to the centre of the piston.

Emily. Is it not similar to the syringe, or squirt, with which you first draw in, and then force out water?

Mrs. B. It is; but you know that we do not wish to force the water out of the pump, at the same end of the pipe, at which we draw it in. The intention of a pump, is to raise water from a spring, or well; the pipe is, therefore, placed perpendicularly over the water, which enters it at the lower extremity, and it issues at a horizontal spout, towards the upper part of the pump; to effect this, there are, besides the piston, two contrivances called valves. The pump, therefore, is rather a more complicated piece of machinery, than the syringe.

Caroline. Pray, Mrs. B., is not the leather, which covers the opening, in the lower board of a pair of bellows, a kind of valve?

Mrs. B. It is, valves are made in various forms; any contrivance, which allows a fluid to pass in one direction, and prevents its return, is called a valve; that of the bellows, and of the common pump, resemble each other, exactly. You can now, I think, understand the structure of the pump.

Its various parts, are delineated in this figure: ([fig. 4. plate 14.](#)) A B is the pipe, or body of the pump, P the piston, V a valve, or little door in the piston, which, opening upwards, admits the water to rise through it, but prevents its returning, and Y, is a similar valve, placed lower down in

the body of the pump; H is the handle, which in this model, serves to work the piston.

When the pump is in a state of inaction, the two valves are closed by their own weight; but when, by working the handle of the pump, the piston ascends; it raises a column of air which rested upon it, and produces a vacuum, between the piston, and the lower valve Y; the air beneath this valve, which is immediately over the surface of the water, consequently expands, and forces its way through it; the water, then, relieved from the pressure of the air, ascends into the pump. A few strokes of the handle, totally excludes the air from the body of the pump, and fills it with water, which, having passed through both the valves, runs out at the spout.

Caroline. I understand this perfectly. When the piston is elevated, the air, and the water, successively rise in the pump, for the same reason as the mercury, rises in the barometer. [Pg 144]

Emily. I thought that water was drawn up into a pump, by suction, in the same manner as water may be sucked through a straw.

Mrs. B. It is so, into the body of the pump; for the power of suction, is no other than that of producing a vacuum over one part of the liquid, into which vacuum the liquid is forced, by the pressure of the atmosphere, on another part. The action of sucking through a straw, consists in drawing in, and confining the breath, so as to produce a vacuum in the mouth; in consequence of which, the air within the straw, rushes into the mouth, and is followed by the liquid, into which, the lower end of the straw, is immersed. The principle, you see, is the same, and the only difference consists in the mode of producing a vacuum. In suction, the muscular powers answer the purpose of the piston and valve.

Emily. Water cannot, then, be raised by a pump, above 32 feet; for the pressure of the atmosphere will not sustain a column of water, above that height.

Mrs. B. I beg your pardon. It is true that there must never be so great a distance as 32 feet, from the level of the water in the well, to the valve in the piston, otherwise the water would not rise through that valve; but when once the water has passed that opening, it is no longer the pressure of air on the reservoir, which makes it ascend; it is raised by lifting it up, as you would raise it in a bucket, of which the piston formed the bottom. This common pump is, therefore, called the sucking, or lifting pump, as it is constructed on both these principles. The rod to which the piston is attached, must be made sufficiently long, to allow the piston to be within 32 feet of the surface of the water in the well, however deep it may be. There is another sort of pump, called the forcing pump: it consists of a forcing power, added to the sucking part of the pump. This additional power, is exactly on the principle of the syringe: by raising the piston, you draw the water into the pump, and by causing it to descend, you force the water out.

Caroline. But the water must be forced out at the upper part of the pump; and I cannot conceive how that can be done by the descent of the piston.

Mrs. B. [Figure 5, plate 14](#), will explain the difficulty. The large pipe, A B, represents the sucking part of the pump, which differs from the lifting pump, only in its piston P, being unfurnished with a valve, in consequence of which the water cannot rise above it. When, therefore, the piston descends, it shuts the valve Y, and forces the water (which has no other vent) into the pipe D: this is likewise furnished with a valve V, which, opening upwards, admits the water to pass, but prevents its return. [Pg 145]

The water, is thus first raised in the pump, and then forced into the pipe, by the alternate ascending, and descending motion of the piston, after a few strokes of the handle to fill the pipe, from whence the water issues at the spout.

Emily. Does not the air pump, which you used in the experiments, on pneumatics, operate upon the same principles as the sucking pump?

Mrs. B. Exactly. The air pump which I used ([plate 1, fig. 2](#).) has two hollow, brass cylinders, called barrels, which are made perfectly true. In each of those barrels, there is a piston; these are worked up, and down, by the same handle; the pistons, are furnished with valves, opening upwards, like those of the common pump: there are valves also, placed at the lower part of each barrel, which open upwards; there are therefore two pumps, united to produce the same effect: two tubes, connect these barrels with the plate, upon which I placed the receivers, which were to be exhausted.

Emily. I now understand how the air pump acts; the receiver contains air, which is exhausted, just as it is by the common pump, before the water begins to rise.

Mrs. B. Having explained the mechanical properties of air, I think it is now time to conclude our lesson. When next we meet, I shall give you some account of wind, and of sound, which will terminate our observations on elastic fluids.

Caroline. And I shall run into the garden, to have the pleasure of pumping, now that I understand the construction of a pump.

Mrs. B. And, to-morrow, I hope you will be able to tell me, whether it is a forcing, or a common lifting pump.

1. (Pg. [136](#)) Into what two kinds are fluids divided?
2. (Pg. [136](#)) There are different kinds of elastic fluids, in what properties are they alike, and in what do they differ?
3. (Pg. [136](#)) In what particular do elastic, differ from non-elastic, fluids?
4. (Pg. [136](#)) What is meant by the elasticity of air?
5. (Pg. [137](#)) What is said respecting the weight of the atmosphere?
6. (Pg. [137](#)) Why do we not feel the pressure of the air?
7. (Pg. [137](#)) What would be the effect of relieving us from atmospheric pressure?
8. (Pg. [138](#)) How may the weight of the air be shown by the aid of the air pump, and a piece of bladder?
9. (Pg. [138](#)) How is this explained?
10. (Pg. [138](#)) How may its elasticity be exhibited, by an apple, and by a bladder?
11. (Pg. [139](#)) What is the absolute weight of a given column of atmospheric air, and how could its whole pressure upon the earth be ascertained?
12. (Pg. [139](#)) How can the weight of a small bulk of air be found?
13. (Pg. [140](#)) In ascertaining the weight of air, we take account of its temperature—Why?
14. (Pg. [140](#)) How could you ascertain the specific gravity of air, and what would it be?
15. (Pg. [140](#)) What are the essential parts of a barometer, as represented [plate 14, fig. 3](#)?
16. (Pg. [141](#)) What sustains the mercury in the tube?
17. (Pg. [141](#)) Of what use are the divisions in the upper part of the instrument?
18. (Pg. [141](#)) To what height will the mercury rise, and what occasions this height to vary?
19. (Pg. [141](#)) When is the mercury highest, in wet, or in dry weather?
20. (Pg. [141](#)) What occasions the sensation of oppression, in damp weather?
21. (Pg. [142](#)) Why will the barometer indicate the height of mountains, or of balloons?
22. (Pg. [142](#)) Is any inconvenience experienced by persons ascending to great heights, and from what cause?
23. (Pg. [142](#)) What occasions the rise and fall of the mercury, in a thermometer?
24. (Pg. [142](#)) To what height will the pressure of the atmosphere raise a column of water?
25. (Pg. [142](#)) What governs the difference between the height of the mercury, and of the water?
26. (Pg. [143](#)) How does the common pump, raise water from a well?
27. (Pg. [143](#)) What is meant by a piston?
28. (Pg. [143](#)) Describe the construction, and use, of a valve.
29. (Pg. [143](#)) What are the parts of the pump, as represented, [fig. 4, plate 14](#)?
30. (Pg. [144](#)) How do these parts act, in raising the water?
31. (Pg. [144](#)) In what does that which is commonly called suction, consist?
32. (Pg. [144](#)) How must the piston be situated in the pump?
33. (Pg. [144](#)) What other kind of pump is described?
34. (Pg. [145](#)) How is the forcing pump constructed, as shown in [plate 14, fig. 5](#)?
35. (Pg. [145](#)) Describe the construction and operation of the air pump, ([fig. 2, plate 1](#).)

CONVERSATION XIII. ON WIND AND SOUND.

[Pg 146]

OF WIND IN GENERAL. OF THE TRADE-WIND. OF THE PERIODICAL TRADE-WINDS. OF THE AERIAL TIDES. OF SOUNDS IN GENERAL. OF SONOROUS BODIES. OF MUSICAL SOUNDS. OF CONCORD OR HARMONY, AND MELODY.

MRS. B.

Well, Caroline, have you ascertained what kind of pump you have in your garden?

Caroline. I think it must be merely a lifting pump, because no more force is required to raise the handle than is necessary to lift its weight; and as in a forcing pump, by raising the handle, you force the water into the smaller pipe, the resistance the water offers, must require an exertion of strength, to overcome it.

Mrs. B. I make no doubt you are right; for lifting pumps, being simple in their construction, are by far the most common.

I have promised to-day to give you some account of the nature of wind. Wind is nothing more than the motion of a stream, or current of air, generally produced by a partial change of temperature in the atmosphere; for when any one part is more heated than the rest, that part is rarefied, the air in consequence rises, and the equilibrium is destroyed. When this happens, there necessarily follows a motion of the surrounding air towards that part, in order to restore it; this spot, therefore, receives winds from every quarter. Those who live to the north of it, experience a north wind; those to the south, a south wind:—do you comprehend this?

Caroline. Perfectly. But what sort of weather must those people have, who live on the spot, where these winds meet and interfere?

Mrs. B. They have most commonly turbulent and boisterous weather, whirlwinds, hurricanes, rain, lightning, thunder, &c. This stormy weather occurs most frequently in the torrid zone, where the heat is greatest: the air being more rarefied there, than in any other part of the globe,

[Pg 147]

is lighter, and consequently, ascends; whilst the air from the north and south, is continually flowing in, to restore the equilibrium.

Caroline. This motion of the air, would produce a regular and constant north wind, to the inhabitants of the northern hemisphere; and a south wind, to those of the southern hemisphere, and continual storms at the equator, where these two adverse winds would meet.

Mrs. B. These winds do not meet, for they each change their direction before they reach the equator. The sun, in moving over the equatorial regions from east to west, rarefies the air as it passes, and causes the denser eastern air to flow westwards, in order to restore the equilibrium, thus producing a regular east wind, about the equator.

Caroline. The air from the west, then, constantly goes to meet the sun, and repair the disturbance which his beams have produced in the equilibrium of the atmosphere. But I wonder how you will reconcile these various winds, Mrs. B.; you first led me to suppose there was a constant struggle between opposite winds at the equator, producing storm and tempest; but now I hear of one regular invariable wind, which must naturally be attended by calm weather.

Emily. I think I comprehend it: do not these winds from the north and south, combine with the easterly wind about the equator, and form, what are called, the trade-winds?

Mrs. B. Just so, my dear. The composition of the two winds, north and east, produces a constant north-east wind; and that of the two winds, south and east, produces a regular south-east wind; these winds extend to about thirty degrees on each side of the equator, the regions further distant from it, experiencing only their respective northerly and southerly winds.

Caroline. But, Mrs. B., if the air is constantly flowing from the poles, to the torrid zone, there must be a deficiency of air, in the polar regions?

Mrs. B. The light air about the equator, which expands, and rises into the upper regions of the atmosphere, ultimately flows from thence, back to the poles, to restore the equilibrium: if it were not for this resource, the polar, atmospheric regions, would soon be exhausted by the stream of air, which, in the lower strata of the atmosphere, they are constantly sending towards the equator.

Caroline. There is then a sort of circulation of air in the atmosphere; the air in the lower strata, flowing from the poles towards the equator, and in the upper strata, flowing back from the equator, towards the poles.

[Pg 148]

Mrs. B. Exactly; I can show you an example of this circulation, on a smaller scale. The air of this room, being more rarefied, than the external air, a wind or current of air is pouring in from the crevices of the windows and doors, to restore the equilibrium; but the light air, with which the room is filled, must find some vent, in order to make way for the heavy air that enters. If you set the door a-jar, and hold a candle near the upper part of it, you will find that the flame will be blown outwards, showing that there is a current of air flowing out from the upper part of the room.—Now place the candle on the floor, close by the door, and you will perceive, by the inclination of the flame, that there is also a current of air, setting into the room.

Caroline. It is just so; the upper current is the warm light air, which is driven out to make way for the stream of cold dense air, which enters the room lower down.

Mrs. B. Besides the general, or trade-winds, there are others, which are called periodical, because they blow in contrary directions, at particular periods.

Emily. I have heard, Mrs. B., that the periodical winds, called, in the torrid zone, the sea and land breezes, blow towards the land, in the day time, and towards the sea, at night: what is the reason of that?

Mrs. B. The land reflects into the atmosphere, a much greater quantity of the sun's rays, than the water; therefore, that part of the atmosphere which is over the land, is more heated and rarefied, than that which is over the sea: this occasions the wind to set in upon the land, as we find that it regularly does on the coast of Guinea, and other countries in the torrid zone. There, they have only the sea breeze, but on the islands, they have, in general, both a land and sea breeze, the latter being produced in the way described; whilst at night, during the absence of the sun, the earth cools, and the air is consequently condensed, and flows from the land, towards the sea, occasioning the land breeze.

Emily. I have heard much of the violent tempests, occasioned by the breaking up of the monsoons; are not they also regular trade-winds?

Mrs. B. They are called periodical trade-winds, as they change their course every half year. This variation is produced by the earth's annual course round the sun; the north pole being inclined towards that luminary one half of the year, the south pole, the other half. During the summer of the northern hemisphere, the countries of Arabia, Persia, India, and China, are much heated, and reflect great quantities of the sun's rays into the atmosphere, by which it becomes extremely rarefied, and the equilibrium consequently destroyed. In order to restore it, the air from the equatorial southern regions, where it is colder, (as well as from the colder northern parts,) must necessarily have a motion towards those parts. The current of air from the equatorial regions, produces the trade-winds for the first six months, in all the seas between the heated continent of Asia, and the equator. The other six months, when it is summer in the southern hemisphere, the

[Pg 149]

ocean and countries towards the southern tropic are most heated, and the air over those parts, more rarefied: then the air about the equator alters its course, and flows exactly in an opposite direction.

Caroline. This explanation of the monsoons is very curious; but what does their breaking up mean?

Mrs. B. It is the name given by sailors to the shifting of the periodical winds; they do not change their course suddenly, but by degrees, as the sun moves from one hemisphere, to the other: this change is usually attended by storms and hurricanes, very dangerous for shipping; so that those seas are seldom navigated at the season of the equinoxes.

Emily. I think I understand the winds in the torrid zone perfectly well; but what is it that occasions the great variety of winds, which occur in the temperate zones? for, according to your theory, there should be only north and south winds, in those climates.

Mrs. B. Since so large a portion of the atmosphere, as is over the torrid zone, is in continued agitation, these agitations in an elastic fluid, which yields to the slightest impression, must extend every way, to a great distance; the air, therefore, in all climates, will suffer more or less perturbation, according to the situation of the country, the position of mountains, valleys, and a variety of other causes: hence it is easy to conceive, that almost every climate, must be liable to variable winds; this is particularly the case in high latitudes, where the earth is less powerfully affected by the sun's rays, than near the equator.

Caroline. I have observed, that the wind, whichever way it blows, almost always falls about sunset.

Mrs. B. Because the rarefaction of air in the particular spot which produces the wind, diminishes as the sun declines, and consequently the velocity of the wind, abates. [Pg 150]

Emily. Since the air is a gravitating fluid, is it not affected by the attraction of the moon and the sun, in the same manner as the waters?

Mrs. B. Undoubtedly; but the ærial tides are as much greater than those of water, as the density of water exceeds that of air, which, as you may recollect, we found to be about 800 to 1.

Caroline. What a prodigious protuberance that must occasion! How much the weight of such a column of air, must raise the mercury in the barometer!

Emily. As this enormous tide of air is drawn up and supported, as it were, by the moon, its weight and pressure, I should suppose, would be rather diminished than increased?

Mrs. B. The weight of the atmosphere is neither increased nor diminished by the ærial tides. The moon's attraction augments the bulk, as much as it diminishes the weight, of the column of air; these effects, therefore, counterbalancing each other, the ærial tides do not affect the barometer.

Caroline. I do not quite understand that.

Mrs. B. Let us suppose that the additional bulk of air at high tide, raises the barometer one inch; and on the other hand, that the support which the moon's attraction affords the air, diminishes its weight or pressure, so as to occasion the mercury to fall one inch; under these circumstances the mercury must remain stationary. Thus, you see, that we can never be sensible of ærial tides by the barometer, on account of the equality of pressure of the atmosphere, whatever be its height.

The existence of ærial tides is not, however, hypothetical; it is proved by the effect they produce on the apparent position of the heavenly bodies; but this I cannot explain to you, till you understand the properties of light.

Emily. And when shall we learn them?

Mrs. B. I shall first explain to you the nature of sound, which is intimately connected with that of air; and I think at our next meeting, we may enter upon the subject of optics.

We have now considered the effects produced by the wide, and extended agitation, of the air; but there is another kind of agitation, of which the air is susceptible—a vibratory trembling motion, which, striking on the drum of the ear, produces *sound*.

Caroline. Is not sound produced by solid bodies? The voice of animals, the ringing of bells, the music of instruments, all proceed from solid bodies. I know of no sound but that of the wind, which is produced by the air. [Pg 151]

Mrs. B. Sound, I assure you, results from a tremulous motion of the air; and the sonorous bodies you enumerate, are merely the instruments by which that peculiar species of motion, is communicated to the air.

Caroline. What! when I ring this little bell, is it the air that sounds, and not the bell?

Mrs. B. Both the bell, and the air, are concerned in the production of sound. But sound, strictly speaking, is a perception excited in the mind, by the motion of the air, on the nerves of the ear; the air, therefore, as well as the sonorous bodies which put it in motion, is only the cause of sound, the immediate effect is produced by the sense of hearing: for without this sense, there would be no sound.

Emily. I can with difficulty conceive that. A person born deaf, it is true, has no idea of sound, because he hears none; yet that does not prevent the real existence of sound, as all those who are not deaf, can testify.

Mrs. B. I do not doubt the existence of sound, to all those who possess the sense of hearing; but it exists neither in the sonorous body, nor in the air, but in the mind of the person whose ear is struck, by the vibratory motion of the air, produced by a sonorous body. Sound, therefore, is a sensation, produced in a living body; life, is as necessary to its existence, as it is to that of feeling or seeing.

To convince you that sound does not exist in sonorous bodies, but that air or some other vehicle, is necessary to its production, endeavour to ring the little bell, after I have suspended it under a receiver in the air pump, from which I shall exhaust the air....

Caroline. This is indeed very strange: though I agitate it so violently, it produces but little sound.

Mrs. B. By exhausting the receiver, I have cut off the communication between the air and the bell; the latter, therefore, cannot impart its motion, to the air.

Caroline. Are you sure that it is not the glass, which covers the bell, that prevents our hearing it?

Mrs. B. That you may easily ascertain, by letting the air into the receiver, and then ringing the bell.

Caroline. Very true; I can hear it now, almost as loud, as if the glass did not cover it; and I can no longer doubt but that air is necessary to the production of sound.

Mrs. B. Not absolutely necessary, though by far the most common vehicle of sound. Liquids, as well as air, are capable of conveying the vibratory motion of a sonorous body, to the organ of hearing; as sound can be heard under water. Solid bodies also, convey sound, as I can soon convince you by a very simple experiment. I shall fasten this string by the middle, round the poker; now raise the poker from the ground, by the two ends of the string, and hold one to each of your ears:—I shall now strike the poker, with a key, and you will find that the sound is conveyed to the ear by means of the strings, in a much more perfect manner, than if it had no other vehicle than the air.

[Pg 152]

Caroline. That it is, certainly, for I am almost stunned by the noise. But what is a sonorous body, Mrs. B.? for all bodies are capable of producing some kind of sound, by the motion they communicate to the air.

Mrs. B. Those bodies are called sonorous, which produce clear, distinct, regular, and durable sounds, such as a bell, a drum, musical strings, wind instruments, &c. They owe this property to their elasticity; for an elastic body, after having been struck, not only returns to its former situation, but having acquired momentum by its velocity, like the pendulum, it springs out on the opposite side. If I draw the string A B, ([fig. 6, plate 14,](#)) which is made fast at both ends, to C, it will not only return to its original position, but proceed onwards, to D.

This is its first vibration; at the end of which, it will retain sufficient velocity to bring it to E, and back again to F, which constitutes its second vibration; the third vibration, will carry it only to G and H, and so on, till the resistance of the air destroys its motion.

The vibration of a sonorous body, gives a tremulous motion to the air around it, very similar to the motion communicated to smooth water, when a stone is thrown into it. This, first produces a small circular wave, around the spot in which the stone falls; the wave spreads, and gradually communicates its motion to the adjacent waters, producing similar waves to a considerable extent. The same kind of waves are produced in the air, by the motion of a sonorous body, but with this difference, that as air, is an elastic fluid, the motion does not consist of regularly extending waves, but of vibrations; and are composed of a motion, forwards and backwards, similar to those of the sonorous body. They differ also, in the one taking place in a plane, the other, in all directions: the ærial undulations, being spherical.

[Pg 153]

Emily. But if the air moves backwards, as well as forwards, how can its motion extend so as to convey sound to a distance?

Mrs. B. The first sphere of undulations, which are produced immediately around the sonorous body, by pressing against the contiguous air, condenses it. The condensed air, though impelled forward by the pressure, reacts on the first set of undulations, driving them back again. The second set of undulations which have been put in motion, in their turn, communicate their motion, and are themselves driven back, by reaction. Thus, there is a succession of waves in the air, corresponding with the succession of waves in the water.

Caroline. The vibrations of sound, must extend much further than the circular waves in water, since sound is conveyed to a great distance.

Mrs. B. The air is a fluid so much less dense than water, that motion is more easily communicated to it. The report of a cannon produces vibrations of the air, which extend to several miles around.

Emily. Distant sound takes some time to reach us, since it is produced at the moment the cannon is fired; and we see the light of the flash, long before we hear the report.

Mrs. B. The air is immediately put in motion, by the firing of a cannon; but it requires time for the

vibrations to extend to any distant spot. The velocity of sound, is computed to be at the rate of 1142 feet in a second.

Caroline. With what astonishing rapidity the vibrations must be communicated! But the velocity of sound varies, I suppose, with that of the air which conveys it. If the wind sets towards us from the cannon, we must hear the report sooner than if it set the other way.

Mrs. B. The direction of the wind makes less difference in the velocity of sound, than you would imagine. If the wind sets from us, it bears most of the ærial waves away, and renders the sound fainter; but it is not very considerably longer in reaching the ear, than if the wind blew towards us. This uniform velocity of sound, enables us to determine the distance of the object, from which it proceeds; as that of a vessel at sea, firing a cannon, or that of a thunder cloud. If we do not hear the thunder, till half a minute after we see the lightning, we conclude the cloud to be at the distance of six miles and a half.

Emily. Pray, how is the sound of an echo produced?

[Pg 154]

Mrs. B. When the ærial vibrations meet with an obstacle, having a hard and regular surface, such as a wall, or rock, they are reflected back to the ear, and produce the same sound a second time; but the sound will then appear to proceed, from the object by which it is reflected. If the vibrations fall perpendicularly on the obstacle, they are reflected back in the same line; if obliquely, the sound returns obliquely, in the opposite direction, the angle of reflection being equal to the angle of incidence.

Caroline. Oh, then, Emily, I now understand why the echo of my voice behind our house is heard so much plainer by you than it is by me, when we stand at the opposite ends of the gravel walk. My voice, or rather, I should say, the vibrations of air it occasions, fall obliquely on the wall of the house, and are reflected by it, to the opposite end of the gravel walk.

Emily. Very true; and we have observed, that when we stand in the middle of the walk, opposite the house, the echo returns to the person who spoke.

Mrs. B. Speaking-trumpets, are constructed on the principle, that sound is reflected. The voice, instead of being diffused in the open air, is confined within the trumpet; and the vibrations which would otherwise spread laterally, fall against the sides of the instrument, and are reflected from the different points of incidence, so as to combine with those vibrations which proceed straight forwards. The vibrations are thus forced onwards, in the direction of the trumpet, so as greatly to increase the sound, to a person situated in that direction. [Figure 7, plate 14](#), will give you a clearer idea, of the speaking-trumpet; in this, lines are drawn to represent the manner, in which we may imagine the sound to be reflected. There is a point in front of the trumpet, F, which is denominated its focus, because the sound is there more intense, than at any other spot. The trumpet used by deaf persons, acts on the same principle; although it does not equally increase the sound.

Emily. Are the trumpets used as musical instruments, also constructed on this principle?

Mrs. B. So far as their form tends to increase the sound, they are; but, as a musical instrument, the trumpet becomes itself the sonorous body, which is made to vibrate by blowing into it, and communicates its vibrations to the air.

I will attempt to give you, in a few words, some notion of the nature of musical sounds, which, as you are fond of music, must be interesting to you.

If a sonorous body be struck in such a manner, that its vibrations, are all performed in regular times, the vibrations of the air, will correspond with them; and striking in the same regular manner on the drum of the ear, will produce the same uniform sensation, on the auditory nerve, and excite the same uniform idea, in the mind; or, in other words, we shall hear one musical tone.

[Pg 155]

But if the vibrations of the sonorous body, are irregular, there will necessarily follow a confusion of ærial vibrations; for a second vibration may commence, before the first is finished, meet it half way on its return, interrupt it in its course, and produce harsh jarring sounds, which are called *discords*.

Emily. But each set of these irregular vibrations, if repeated alone, and at equal intervals, would, I suppose, produce a musical tone? It is only their irregular interference, which occasions discord.

Mrs. B. Certainly. The quicker a sonorous body vibrates, the more acute, or sharp, is the sound produced; and the slower the vibrations, the more grave will be the note.

Caroline. But if I strike any one note of the piano-forte, repeatedly, whether quickly or slowly, it always gives the same tone.

Mrs. B. Because the vibrations of the same string, at the same degree of tension, are always of a similar duration. The quickness, or slowness of the vibrations, relate to the single tones, not to the various sounds which they may compose, by succeeding each other. Striking the note in quick succession, produces a more frequent repetition of the tone, but does not increase the velocity of the vibrations of the string.

The duration of the vibrations of strings, or wires, depends upon their length, their thickness, or weight, and their degree of tension: thus, you find, the low bass notes are produced by long,

thick, loose strings; and the high treble notes by short, small, and tight strings.

Caroline. Then, the different length, and size, of the strings of musical instruments, serve to vary the duration of the vibrations, and consequently, the acuteness or gravity of the notes?

Mrs. B. Yes. Among the variety of tones, there are some which, sounded together, please the ear, producing what we call harmony, or concord. This arises from the agreement of the vibrations of the two sonorous bodies; so that some of the vibrations of each, strike upon the ear at the same time. Thus, if the vibrations of two strings are performed in equal times, the same tone is produced by both, and they are said to be in unison. [Pg 156]

Emily. Now, then, I understand why, when I tune my harp, in unison with the piano-forte, I draw the strings tighter, if it is too low, or loosen them, if it is too high a pitch: it is in order to bring them to vibrate, in equal times, with the strings of the piano-forte.

Mrs. B. But concord, you know, is not confined to unison; for two different tones, harmonize in a variety of cases. When the vibrations of one string (or other sonorous body) vibrate in double the time of another, the second vibration of the latter, will strike upon the ear, at the same instant, as the first vibration of the former; and this is the concord of an octave.

If the vibrations of two strings are as two to three, the second vibration of the first, corresponds with the third vibration of the latter, producing the harmony called, a fifth.

Caroline. So, then, when I strike the key-note with its fifth, I hear every second vibration of one, and every third of the other, at the same time?

Mrs. B. Yes; and the key-note, struck with the fourth, is likewise a concord, because the vibrations, are as three to four. The vibrations of a major third, with the key-note, are as four to five; and those of a minor third, as five to six.

There are other tones, which, though they cannot be struck together without producing discord, if struck successively, give us that succession of pleasing sounds, which is called melody. Harmony, you perceive, arises from the combined effect of two, or more concordant sounds, while melody, is the result of certain simple sounds, which succeed each other. Upon these general principles, the science of music is founded; but, I am not sufficiently acquainted with it, to enter into it any further.

We shall now, therefore, take leave of the subject of sound; and, at our next interview, enter upon that of optics, in which we shall consider the nature of light, vision, and colours.

Questions

1. (Pg. 146) What is wind, and how is it generally produced?
2. (Pg. 146) How do the winds blow, around the place where the air becomes rarefied?
3. (Pg. 146) What effect is likely to be produced where the winds meet?
4. (Pg. 147) In what part of the globe is the air most rarefied, and what is the consequence?
5. (Pg. 147) How do these winds change their direction as they approach the equator?
6. (Pg. 147) How are the trade-winds produced, and how far do they extend?
7. (Pg. 147) How is the equilibrium in the air restored?
8. (Pg. 148) How can contrary currents of air be shown in a room?
9. (Pg. 148) What causes this?
10. (Pg. 148) What is meant by a periodical wind?
11. (Pg. 148) What occasions the land and sea breezes, and where do they prevail?
12. (Pg. 149) What are monsoons?
13. (Pg. 149) How do they change, and what is the cause?
14. (Pg. 149) What is meant by their breaking up, and what effect is in general produced?
15. (Pg. 149) Why is the wind most variable in high latitudes?
16. (Pg. 150) Why is the wind apt to lessen about sunset?
17. (Pg. 150) What effect must the sun and moon produce upon the atmosphere, from their attraction?
18. (Pg. 150) Why do not the ærial tides affect the barometer?
19. (Pg. 151) How is sound produced?
20. (Pg. 151) Does sound exist in the sonorous body, if not, what is it?
21. (Pg. 151) By what experiment might we prove that air is the principal vehicle of sound?
22. (Pg. 152) What other bodies convey sound, and how can it be shown that they do so?
23. (Pg. 152) What is meant by a sonorous body?
24. (Pg. 152) To what do they owe this property?
25. (Pg. 152) How is this explained by [fig. 6, plate 14](#)?
26. (Pg. 152) How is it illustrated by a stone thrown into water, and how far does this illustration apply?
27. (Pg. 153) How are the vibrations propagated?
28. (Pg. 153) How can we prove that sound, does not travel as rapidly as light?
29. (Pg. 153) At what rate is sound said to travel?
30. (Pg. 153) Is the velocity much influenced by the direction of the wind?
31. (Pg. 153) How will sound enable us to judge of the distance of objects?
32. (Pg. 154) How are echoes produced?
33. (Pg. 154) What is the operation and effect of the speaking-trumpet ([fig. 7, plate 14](#))?
34. (Pg. 155) How is a musical tone produced?
35. (Pg. 155) What occasions discords?
36. (Pg. 155) Upon what does the acuteness or gravity of a sound depend?
37. (Pg. 155) Does the force, with which a string is struck, affect the rapidity of its vibrations?

38. (Pg. 155) How are the strings made to produce the high and low notes?
39. (Pg. 155) What is meant by harmony, or concord, and how is it produced?
40. (Pg. 156) When are strings said to be in unison?
41. (Pg. 156) How are octaves produced?
42. (Pg. 156) How are fifths produced?
43. (Pg. 156) How major and minor thirds?
44. (Pg. 156) What is meant by melody, and in what particular does it differ from harmony?

PLATE XV.

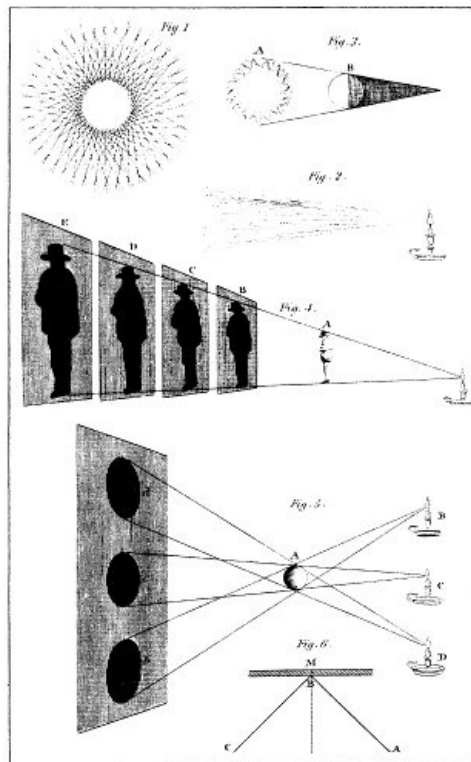

CONVERSATION XIV. ON OPTICS.

[Pg 157]

OF LUMINOUS, TRANSPARENT, AND OPAQUE BODIES. OF THE RADIATION OF LIGHT. OF SHADOWS. OF THE REFLECTION OF LIGHT. OPAQUE BODIES SEEN ONLY BY REFLECTED LIGHT. VISION EXPLAINED. CAMERA OBSCURA. IMAGE OF OBJECTS ON THE RETINA.

CAROLINE.

I long to begin our lesson to-day, Mrs. B., for I expect that it will be very entertaining.

Mrs. B. Optics is that branch of philosophy, which treats of the nature and properties of light. It is certainly one of the most interesting branches of Natural Philosophy, but not one of the easiest to understand; I must, therefore, beg that you will give me your undivided attention.

I shall first inquire, whether you comprehend the meaning of a *luminous body*, an *opaque body*, and a *transparent body*.

Caroline. A luminous body is one that shines; an opaque....

Mrs. B. Do not proceed to the second, until we have agreed upon the definition of the first. All bodies that shine, are not luminous; for a luminous body is one that shines by its own light; as the sun, the fire, a candle, &c.

Emily. Polished metal then, when it shines with so much brilliancy, is not a luminous body?

Mrs. B. No, for it would be dark, if it did not receive light from a luminous body; it belongs, therefore, to the class of dark, as well as of opaque bodies, which comprehends all such as are neither luminous, nor will admit the light to pass through them.

Emily. And transparent bodies, are those which admit the light to pass through them, such as glass and water.

Mrs. B. You are right. Transparent, or pellucid bodies, are frequently called mediums, because they allow the rays of light to pass through them; and the rays which pass through, are said to be transmitted by them.

Light, when emanated from the sun, or any other luminous body, is projected forward in straight lines, in every possible direction; so that the luminous body, is not only the general centre, from whence all the rays proceed; but every point of it, may be considered as a centre, which radiates light in every direction. ([Fig. 1. plate 15.](#))

Emily. But do not the rays which are projected in different directions, and cross each other, interfere, and impede each other's course?

Mrs. B. Not at all. The particles of light, are so extremely minute, that they are never known to interfere with each other. A ray of light, is a single line of light, projected from a luminous body; and a pencil of rays, is a collection of rays, proceeding from any one point of a luminous body, as [fig. 2.](#)

Caroline. Is light then a substance composed of particles, like other bodies?

Mrs. B. That is a disputed point, upon which I cannot pretend to decide. In some respects, light is obedient to the laws which govern bodies; in others, it appears to be independent of them: thus, though its course is guided by the laws of motion, it does not seem to be influenced by those of gravity. It has never been discovered to have weight, though a variety of interesting experiments have been made with a view of ascertaining that point; but we are so ignorant of the intimate nature of light, that an attempt to investigate it, would lead us into a labyrinth of perplexity, if not of error; we shall, therefore, confine our attention to those properties of light, which are well ascertained.

Let us return to the examination of the effects of the radiation of light, from a luminous body. Since the rays of light are projected in straight lines, when they meet with an opaque body through which they are unable to pass, they are stopped short in their course; for they cannot move in a curve line round the body.

Caroline. No, certainly; for it would require some other force besides that of projection, to produce motion in a curve line.

Mrs. B. The interruption of the rays of light, by the opaque body, produces, therefore, darkness on the opposite side of it: and if this darkness fall upon a wall, a sheet of paper, or any object whatever, it forms a shadow.

Emily. A shadow, then, is nothing more than darkness produced by the intervention of an opaque body, which prevents the rays of light from reaching an object behind it.

Caroline. Why then are shadows of different degrees of darkness; for I should have supposed, from your definition of a shadow, that it would have been perfectly black? [Pg 159]

Mrs. B. It frequently happens that a shadow is produced by an opaque body, interrupting the course of the rays from one luminous body, while light from another, reaches the space where the shadow is formed; in which case, the shadow is proportionally fainter. This happens when the opaque body is lighted by two candles: if you extinguish one of them, the shadow will be both deeper, and more distinct.

Caroline. But yet it will not be perfectly dark.

Mrs. B. Because it is still slightly illuminated by light reflected from the walls of the room, and other surrounding objects.

You must observe, also, that when a shadow is produced by the interruption of rays from a single luminous body, the darkness is proportioned to the intensity of the light.

Emily. I should have supposed the contrary; for as the light reflected from surrounding objects on the shadow, must be in proportion to the intensity of the light, the stronger the light, the more the shadow will be illumined.

Mrs. B. Your remark is perfectly just; but as we have no means of estimating the degrees of light, and of darkness, but by comparison, the strongest light will appear to produce the deepest shadow. Hence a total eclipse of the sun, occasions a more sensible darkness than midnight, as it is immediately contrasted with the strong light of noonday.

Caroline. The reappearance of the sun, after an eclipse, must, by the same contrast, appear remarkably brilliant.

Mrs. B. Certainly. There are several things to be observed, in regard to the form, and extent, of shadows. If the luminous body A ([fig. 3.](#)) is larger than the opaque body B, the shadow will gradually diminish in size, till it terminates in a point.

Caroline. This is the case with the shadows of the earth, and the moon; as the sun, which illumines them, is larger than either of those bodies. And why is it not the case with the shadows of terrestrial objects? Their shadows, far from diminishing, are always larger than the object, and increase with the distance from it.

Mrs. B. In estimating the effect of shadows, we must consider the dimensions of the luminous body; when the luminous body is less, than the opaque body, the shadow will increase with the distance. This will be best exemplified, by observing the shadow of an object lighted by a candle. [Pg 160]

Emily. I have often noticed, that the shadow of my figure, against the wall, grows larger, as it is

more distant from me, which is owing, no doubt, to the candle that shines on me, being much smaller than myself.

Mrs. B. Yes. The shadow of a figure as A, ([fig. 4.](#)) varies in size, according to the distance of the several surfaces B C D E, on which it is described.

Caroline. I have observed, that two candles, produce two shadows from the same object; whilst it would appear, from what you said, that they should rather produce only half a shadow, that is to say, a very faint one.

Mrs. B. The number of lights (in different directions) while it decreases the intensity of the shadows, increases their number, which always corresponds with that of the lights; for each light, makes the opaque body cast a different shadow, as illustrated by [fig. 5.](#) which represents a ball A, lighted by three candles, B, C, D; and you observe the light B, produces the shadow *b*, the light C, the shadow *c*, and the light D, the shadow *d*; but neither of these shadows will be very dark, because the light of one candle only, is intercepted by the ball; and the spot is still illuminated by the other two.

Emily. I think we now understand the nature of shadows very well; but pray, what becomes of the rays of light, which opaque bodies arrest in their course, and the interruption of which, is the occasion of shadows?

Mrs. B. Your question leads to a very important property of light, *Reflection*. When rays of light encounter an opaque body, they cannot pass through it, and part of them are absorbed by it, and part are reflected, and rebound; just as an elastic ball rebounds, when struck against a wall.

By reflection, we mean that the light is turned back again, through the same medium which it had traversed in its first course.

Emily. And is light, in its reflection, governed by the same laws, as solid, elastic bodies?

Mrs. B. Exactly. If a ray of light fall perpendicularly on an opaque body, it is reflected back in the same line, towards the point whence it proceeded. If it fall obliquely, it is reflected obliquely, but in the opposite direction; the ray which falls upon the reflecting surface, is called the incident ray, and that which leaves it, the reflected ray; the angle of incidence, is always equal to the angle of reflection. You recollect that law in mechanics? [Pg 161]

Emily. Oh yes, perfectly.

Mrs. B. If you will shut the shutters, we will admit a ray of the sun's light, through a very small aperture, and I can show you how it is reflected. I now hold this mirror, so that the ray shall fall perpendicularly upon it.

Caroline. I see the ray which falls upon the mirror, but not that which is reflected by it.

Mrs. B. Because it is turned directly back again; and the ray of incidence, and that of reflection, are confounded together, both being in the same line, though in opposite directions.

Emily. The ray then, which appears to us single, is really double, and is composed of the incident ray, proceeding to the mirror, and of the reflected ray, returning from the mirror.

Mrs. B. Exactly so. We will now separate them, by holding the mirror M, ([fig. 6.](#)) in such a manner, that the incident ray, A B, shall fall obliquely upon it—you see the reflected ray, B C, is marching off in another direction. If we draw a line from the point of incidence B, perpendicularly, to the mirror, it will divide the angle of incidence, from the angle of reflection, and you will see that they are equal.

Emily. Exactly; and now, that you hold the mirror, so that the ray falls more obliquely upon it, it is also reflected more obliquely, preserving the equality of the angles of incidence, and of reflection.

Mrs. B. It is by reflected rays only, that we see opaque objects. Luminous bodies, send rays of light immediately to our eyes, but the rays which they send to other bodies, are invisible to us, and are seen, only when they are reflected by those bodies, to our eyes.

Emily. But have we not just seen the ray of light, in its passage from the sun to the mirror, and its reflections? yet, in neither case, were those rays in a direction to enter our eyes.

Mrs. B. What you saw, was the light reflected to your eyes, by small particles of dust floating in the air, and on which the ray shone, in its passage to, and from, the mirror.

Caroline. Yet I see the sun, shining on that house yonder, as clearly as possible.

Mrs. B. Indeed you cannot see a single ray, which passes from the sun to the house; you see, by the aid of those rays, which enter your eyes; therefore, it is the rays which are reflected by the house, to you, and not those which proceed directly from the sun, to the house, that render the building visible to you. [Pg 162]

Caroline. Why then does one side of the house appear to be in sunshine, and the other in shade? for, if I cannot see the sun shine upon it, the whole of the house should appear in the shade.

Mrs. B. That side of the house, which the sun shines upon, receives, and reflects more light, and therefore, appears more luminous and vivid, than the side which is in shadow; for the latter is

illuminated only, by rays reflected upon it by other objects; these rays are, therefore, twice reflected before they reach your sight; and as light is more, or less, absorbed by the bodies it strikes upon, every time a ray is reflected, its intensity is diminished.

Caroline. Still I cannot reconcile to myself, the idea that we do not see the sun's rays shining on objects, but only those which such objects reflect to us.

Mrs. B. I do not, however, despair of convincing you of it. Look at that large sheet of water; can you tell why the sun appears to shine on one part of it only?

Caroline. No, indeed; for the whole of it is equally exposed to the sun. This partial brilliancy of water, has often excited my wonder; but it has struck me more particularly by moonlight. I have frequently observed a vivid streak of moonshine on the sea, while the rest of the water remained in deep obscurity, and yet there was no apparent obstacle to prevent the moon from shining equally on every part of the water.

Mrs. B. By moonlight the effect is more remarkable, on account of the deep obscurity of the other parts of the water; while by the sun's light, the effect is too strong for the eye to be able to observe it so distinctly.

Caroline. But, if the sun really shines on every part of that sheet of water, why does not every part of it, reflect rays to my eyes?

Mrs. B. The reflected rays, are not attracted out of their natural course, by your eyes. The direction of a reflected ray, you know, depends on that of the incident ray; the sun's rays, therefore, which fall with various degrees of obliquity upon the water, are reflected in directions equally various; some of these will meet your eyes, and you will see them, but those which fall elsewhere, are invisible to you.

[Pg 163]

Caroline. The streak of sunshine, then, which we now see upon the water, is composed of those rays which by their reflection, happen to fall upon my eyes?

Mrs. B. Precisely.

Emily. But is that side of the house yonder, which appears to be in shadow, really illuminated by the sun, and its rays reflected another way?

Mrs. B. No; that is a different case, from the sheet of water. That side of the house, is really in shadow; it is the west side, which the sun cannot shine upon, till the afternoon.

Emily. Those objects, then, which are illumined by reflected rays, and those which receive direct rays from the sun, but which do not reflect those rays towards us, appear equally in shadow?

Mrs. B. Certainly; for we see them both illumined by reflected rays. That part of the sheet of water, over which the trees cast a shadow, by what light do you see it?

Emily. Since it is not by the sun's direct rays, it must be by those reflected on it from other objects, and which it again reflects to us.

Caroline. But if we see all terrestrial objects by reflected light, (as we do the moon,) why do they appear so bright and luminous? I should have supposed that reflected rays, would have been dull and faint, like those of the moon.

Mrs. B. The moon reflects the sun's light, with as much vividness as any terrestrial object. If you look at it on a clear night, it will appear as bright as a sheet of water, the walls of a house, or any object seen by daylight, and on which the sun shines. The rays of the moon are doubtless feeble, when compared with those of the sun; but that would not be a fair comparison, for the former are incident, the latter, reflected rays.

Caroline. True; and when we see terrestrial objects by moonlight, the light has been twice reflected, and is consequently, proportionally fainter.

Mrs. B. In traversing the atmosphere, the rays, both of the sun, and moon, lose some of their light. For though the pure air, is a transparent medium, which transmits the rays of light freely, we have observed, that near the surface of the earth, it is loaded with vapours and exhalations, by which some portion of them are absorbed.

Caroline. I have often noticed, that an object on the summit of a hill, appears more distinct, than one at an equal distance in a valley, or a plain; which is owing, I suppose, to the air being more free from vapours in an elevated situation, and the reflected rays, being consequently brighter.

[Pg 164]

Mrs. B. That may have some sensible effect; but, when an object on the summit of a hill, has a back ground of light sky, the contrast with the object, makes its outline more distinct.

Caroline. I now feel well satisfied, that we see opaque objects, only by reflected rays; but I do not understand, how these rays, show us the objects from which they proceed.

Mrs. B. I shall hereafter describe the structure of the eye, very particularly, but will now observe, that the small round spot, which is generally called the sight of the eye, is properly denominated the *pupil*; and that the *retina*, is an expansion of the optic nerve on the back part of the ball of the eye, upon which, as upon a screen, the rays fall, which enter at the pupil. The rays of light, enter at the pupil of the eye, and proceed to the retina; and there they describe the figure, colour, and

(excepting size) form a perfect representation of the object, from which they proceed. We shall again close the shutters, and admit the light, through the small hole made for that purpose, and you will see a picture, on the wall, opposite the aperture, similar to that which is delineated on the retina of the eye. The picture is somewhat confused, but by using a lens, to bring the rays to a focus, it will be rendered very distinct.

Caroline. Oh, how wonderful! There is an exact picture in miniature of the garden, the gardener at work, the trees blown about by the wind. The landscape, would be perfect, if it were not reversed; the ground, being above, and the sky beneath.

Mrs. B. It is not enough to admire, you must understand, this phenomenon, which is called a *camera obscura*, or dark chamber; from the necessity of darkening the room, in order to exhibit it. The camera obscura, sometimes consists of a small box, properly fitted up, to represent external objects.

This picture, you now see, is produced by the rays of light, reflected from the various objects in the garden, and which are admitted through the hole in the window shutter.

PLATE XVI.

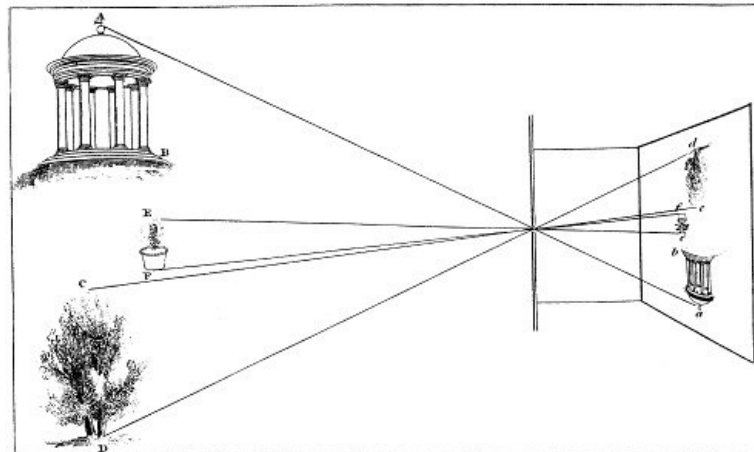

The rays from the glittering weathercock, at the top of the alcove, A, (plate 16.) represent it in this spot, a; for the weathercock, being much higher than the aperture in the shutter, only a few of the rays, which are reflected by it, in an obliquely descending direction, can find entrance there. The rays of light, you know, always move in straight lines; those, therefore, which enter the room, in a descending direction, will continue their course in the same direction, and will consequently fall upon the lower part of the wall opposite the aperture, and represent the weathercock, reversed in that spot, instead of erect, in the uppermost part of the landscape.

[Pg 165]

Emily. And the rays of light, from the steps, (B) of the alcove, in entering the aperture, ascend, and will describe those steps in the highest, instead of the lowest, part of the landscape.

Mrs. B. Observe, too, that the rays coming from the alcove, which is to our left, describe it on the wall, to the right; while those, which are reflected by the walnut tree, C D, to our right, delineate its figure in the picture, to the left, c d. Thus the rays, coming in different directions, and proceeding always in right lines, cross each other at their entrance through the aperture; those which come from above, proceed below, those from the right, go to the left, those from the left, towards the right; thus every object is represented in the picture, as occupying a situation, the very reverse of that which it does in nature.

Caroline. Excepting the flower-pot, E F, which, though its position is reversed, has not changed its situation in the landscape.

Mrs. B. The flower-pot, is directly in front of the aperture; so that its rays, fall perpendicularly upon it, and consequently proceed perpendicularly to the wall, where they delineate the object, directly behind the aperture.

Emily. And is it thus, that the picture of objects, is painted on the retina of the eye?

Mrs. B. Precisely. The pupil of the eye, through which the rays of light enter, represents the aperture in the window-shutter; and the image, delineated on the retina, is exactly similar to the picture on the wall.

Caroline. You do not mean to say, that we see only the representation of the object, which is painted on the retina, and not the object itself?

Mrs. B. If, by sight, you understand that sense, by which the presence of objects is perceived by the mind, through the means of the eyes, we certainly see only the image of those objects, painted on the retina.

Caroline. This appears to me quite incredible.

Mrs. B. The nerves, are the only part of our frame, capable of sensation: they appear, therefore, to be the instruments, which the mind employs in its perceptions; for a sensation, always conveys an idea, to the mind. Now it is known, that our nerves can be affected only by contact; and for

[Pg 166]

this reason, the organs of sense, cannot act at a distance: for instance, we are capable of smelling only particles which are actually in contact with the nerves of the nose. We have already observed, that the odour of a flower consists in effluvia, composed of very minute particles, which penetrate the nostrils, and strike upon the olfactory nerves, which instantly convey the idea of odour to the mind.

Emily. And sound, though it is said to be heard at a distance, is, in fact, heard only when the vibrations of the air, which convey it to our ears, strike upon the auditory nerve.

Caroline. There is no explanation required, to prove that the senses of feeling and of tasting, are excited only by contact.

Mrs. B. And I hope to convince you, that the sense of sight, is so likewise. The nerves, which constitute the sense of sight, are not different in their nature from those of the other organs; they are merely instruments which convey ideas to the mind, and can be affected only on contact. Now, since real objects cannot be brought to touch the optic nerve, the image of them is conveyed thither by the rays of light, proceeding from real objects, which actually strike upon the optic nerve, and form that image which the mind perceives.

Caroline. While I listen to your reasoning, I feel convinced; but when I look upon the objects around, and think that I do not see them, but merely their image painted in my eyes, my belief is again staggered. I cannot reconcile to myself, the idea, that I do not really see this book which I hold in my hand, nor the words which I read in it.

Mrs. B. Did it ever occur to you as extraordinary, that you never beheld your own face?

Caroline. No; because I so frequently see an exact representation of it in the looking-glass.

Mrs. B. You see a far more exact representation of objects on the retina of your eye: it is a much more perfect mirror, than any made by art.

Emily. But is it possible, that the extensive landscape, which I now behold from the window, should be represented on so small a space, as the retina of the eye?

Mrs. B. It would be impossible for art to paint so small and distinct a miniature; but nature works with a surer hand, and a more delicate pencil. That power alone, which forms the feathers of the butterfly, and the organs of the minutest insect, can pourtray so admirable and perfect a miniature, as that which is represented on the retina of the eye.

[Pg 167]

Caroline. But, Mrs. B., if we see only the image of objects, why do we not see them reversed, as you showed us they were, in the camera obscura? Is not that a strong argument against your theory?

Mrs. B. Not an unanswerable one, I hope. The image on the retina, it is true, is reversed, like that in the camera obscura; as the rays, from the different parts of the landscape, intersect each other on entering the pupil, in the same manner as they do, on entering the camera obscura. The scene, however, does not excite the idea of being inverted, because we always see an object in the direction of the rays which it sends to us.

Emily. I confess I do not understand that.

Mrs. B. It is, I think, a difficult point to explain clearly. A ray which comes from the upper part of an object, describes the image on the lower part of the retina; but, experience having taught us, that the direction of that ray is from above, we consider that part of the object it represents as uppermost. The rays proceeding from the lower part of an object, fall upon the upper part of the retina; but as we know their direction to be from below, we see that part of the object they describe as the lowest.

Caroline. When I want to see an object above me, I look up; when an object below me, I look down. Does not this prove that I see the objects themselves? for if I beheld only the image, there would be no necessity for looking up or down, according as the object was higher or lower, than myself.

Mrs. B. I beg your pardon. When you look up, to an elevated object, it is in order that the rays reflected from it, should fall upon the retina of your eyes; but the very circumstance of directing your eyes upwards, convinces you that the object is elevated, and teaches you to consider as uppermost, the image it forms on the retina, though it is, in fact, represented in the lowest part of it. When you look down upon an object, you draw your conclusion from a similar reasoning; it is thus that we see all objects in the direction of the rays which reach our eyes.

But I have a further proof in favour of what I have advanced, which, I hope, will remove your remaining doubts: I shall, however, defer it till our next meeting, as the lesson has been sufficiently long to-day.

Questions

1. (Pg. 157) What is optics?
2. (Pg. 157) What is meant by a luminous body?
3. (Pg. 157) What is meant by a dark body, and what by an opaque body?
4. (Pg. 157) What are transparent bodies?
5. (Pg. 157) What is a medium?

6. (Pg. [158](#)) How is light projected from luminous bodies, and how, from every point of such bodies, ([fig. 1, plate 15](#))?
7. (Pg. [158](#)) Why do not the rays of light from different points, stop each other's progress?
8. (Pg. [158](#)) What is a ray, and what a pencil of rays? [fig. 2, plate 15.](#)
9. (Pg. [158](#)) Do we know whether light is a substance, similar to bodies in general?
10. (Pg. [158](#)) When a ray of light falls upon an opaque body, what is the result?
11. (Pg. [159](#)) In what does shadow consist?
12. (Pg. [159](#)) Why are they, in general, but partially dark?
13. (Pg. [159](#)) Upon what does the intensity of a shadow depend?
14. (Pg. [159](#)) How are shadows affected by the size of the luminous body, as represented in [plate 15, fig. 3](#)?
15. (Pg. [159](#)) When is the shadow larger than the intercepting body?
16. (Pg. [160](#)) What is explained by [fig. 4, plate 15](#)?
17. (Pg. [160](#)) What will be the effect of several lights, as in [fig. 5, plate 15](#)?
18. (Pg. [160](#)) Why will neither of these shadows be very dark?
19. (Pg. [160](#)) What becomes of the light which falls upon an opaque body?
20. (Pg. [160](#)) What is meant by reflection?
21. (Pg. [161](#)) What is meant by the incident, and reflected rays?
22. (Pg. [161](#)) What is the result, when the incident ray falls perpendicularly, and what, when it falls obliquely?
23. (Pg. [161](#)) What two angles are always equal in this case?
24. (Pg. [161](#)) To what law in mechanics, is this analogous, as represented in [fig. 4, plate 2](#)?
25. (Pg. [161](#)) What is represented by [fig. 6, plate 15](#)?
26. (Pg. [161](#)) By what light are we enabled to see opaque, and by what, luminous bodies?
27. (Pg. [161](#)) What enables us to see a ray of light in its passage, through a darkened room?
28. (Pg. [162](#)) By what reasoning would you prove that an object, such, for example, as a house, is seen by reflected light?
29. (Pg. [162](#)) Why may one side of such object appear more bright than another side?
30. (Pg. [162](#)) How is the fact exemplified by the sun, or moon, shining upon water?
31. (Pg. [162](#)) Why is this best evinced by moonlight?
32. (Pg. [163](#)) By what light do we see the moon, and why is it comparatively feeble?
33. (Pg. [163](#)) What circumstance, renders objects seen by moonlight, still less vivid?
34. (Pg. [164](#)) What is meant by the pupil of the eye?
35. (Pg. [164](#)) What by the retina?
36. (Pg. [164](#)) How do the rays of light operate on the eye in producing vision?
37. (Pg. [164](#)) How may this be exemplified, in a darkened room?
38. (Pg. [164](#)) What is meant by a *camera obscura*?
39. (Pg. [164](#)) How is it explained in [plate 16](#)?
40. (Pg. [165](#)) Why are the objects inverted and reversed?
41. (Pg. [165](#)) What analogy is there between the camera obscura, and the eye?
42. (Pg. [165](#)) Is it the object, or its picture on the retina, which presents to the mind an idea of the object seen?
43. (Pg. [166](#)) By what organs is sensation produced, and how must these organs be affected?
44. (Pg. [166](#)) How will the idea of contact, apply to objects not touching the eye?
45. (Pg. [167](#)) Why do not objects appear reversed to the eye, as in the camera obscura?

CONVERSATION XV. OPTICS—*continued.* ON THE ANGLE OF VISION, AND THE REFLECTION OF MIRRORS.

[Pg 168]

ANGLE OF VISION. REFLECTION OF PLAIN MIRRORS. REFLECTION OF CONVEX MIRRORS. REFLECTION OF CONCAVE MIRRORS.

CAROLINE.

Well, Mrs. B., I am very impatient to hear what further proofs you have to offer, in support of your theory. You must allow, that it was rather provoking to dismiss us as you did at our last meeting.

Mrs. B. You press so hard upon me with your objections, that you must give me time to recruit my forces.

Can you tell me, Caroline, why objects at a distance, appear smaller than they really are?

Caroline. I know no other reason than their distance.

Mrs. B. It is a fact, that distance causes objects to appear smaller, but to state the fact, is not to give the reason. We must refer again to the camera obscura, to account for this circumstance; and you will find, that the different apparent dimensions of objects at different distances, proceed from our seeing, not the objects themselves, but merely their image on the retina. [Fig. 1, plate 17](#), represents a row of trees, as viewed in the camera obscura. I have expressed the direction of the rays, from the objects to the image, by lines. Now, observe, the ray which comes from the top of the nearest tree, and that which comes from the foot of the same tree, meet at the aperture, forming an angle of about twenty-five degrees; the angle under which we see any object, is

called, the visual angle, or, angle of vision. These rays cross each other at the aperture, forming equal angles on each side of it, and represent the tree inverted in the camera obscura. The degrees of the image, are considerably smaller than those of the object, but the proportions are perfectly preserved.

PLATE XVII.

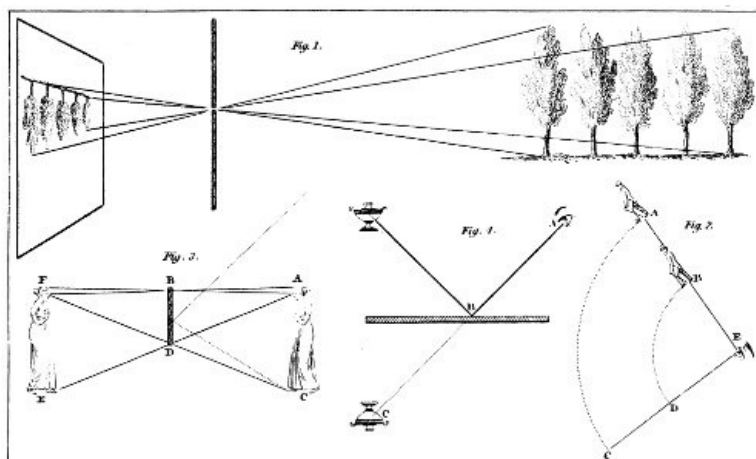

Now, let us notice the upper and lower ray, from the most distant tree; they form an angle of not more than twelve or fifteen degrees, and an image of proportional dimensions. Thus, two objects of the same size, as the two trees of the avenue, form figures of different sizes in the camera obscura, according to their distance; or, in other words, according to the angle of vision under which they are seen. Do you understand this?

[Pg 169]

Caroline. Perfectly.

Mrs. B. Then you have only to suppose, that the representation in the camera obscura, is similar to that on the retina.

Now, since objects of the same magnitudes, appear to be of different dimensions, when at different distances from us, let me ask you which it is, that you see; the real objects, which, we know, do not vary in size, or the images, which, we know, do vary, according to the angle of vision under which we see them?

Caroline. I must confess, that reason is in favour of the latter. But does that chair, at the further end of the room, form an image on my retina, much smaller than this which is close to me? they appear exactly of the same size.

Mrs. B. Our senses are imperfect, but the experience we acquire by the sense of touch, corrects the illusions of our sight, with regard to objects within our reach. You are so perfectly convinced, of the real size of objects, which you can handle, that you do not attend to the apparent difference.

Does that house appear to you much smaller, than when you are close to it?

Caroline. No, because it is very near us.

Mrs. B. And yet you can see the whole of it, through one of the windows of this room. The image of the house on your retina must, therefore, be smaller than that of the window through which you see it. It is your knowledge of the real magnitude of the house which prevents your attending to its apparent size. If you were accustomed to draw from nature, you would be fully aware of this difference.

Emily. And pray, what is the reason that, when we look up an avenue, the trees not only appear smaller as they are more distant, but seem gradually to approach each other, till they meet in a point?

Mrs. B. Not only the trees, but the road which separates the two rows, forms a smaller visual angle, in proportion as it is more distant from us; therefore, the width of the road gradually diminishes, as well as the size of the trees, till at length the road apparently terminates in a point, at which the trees seem to meet.

[Pg 170]

Emily. I am very glad to understand this, for I have lately begun to learn perspective, which appeared to me a very dry study; but now that I am acquainted with some of the principles on which it is founded, I shall find it much more interesting.

Caroline. In drawing a view from nature, it seems that we do not copy the real objects, but the image they form on the retina of our eyes?

Mrs. B. Certainly. In sculpture, we copy nature as she really exists; in painting, we represent her, as she appears to us.

We must now conclude the observations that remain to be made, on the angle of vision.

If the rays, proceeding from the extremities of an object, with an ordinary degree of illumination, do not enter the eye under an angle of more than two seconds, which is the 1-1800th part of a

degree, it is invisible. There are, consequently, two cases in which objects may be invisible; if they are either so small, or so distant, as to form an angle of less than two seconds of a degree.

In like manner, if the velocity of a body does not exceed 20 degrees in an hour, its motion is imperceptible.

Caroline. A very rapid motion may then be imperceptible, provided the distance of the moving body, is sufficiently great.

Mrs. B. Undoubtedly; for the greater its distance, the smaller will be the angle, under which its motion will appear to the eye. It is for this reason, that the motion of the celestial bodies is invisible, although inconceivably rapid.

Emily. I am surprised, that so great a velocity as 20 degrees an hour, should be invisible.

Mrs. B. The real velocity depends upon the space comprehended in each degree, and upon the time, in which the moving body, passes over that space. But we can only know the extent of this space, by knowing the distance of the moving body, from its centre of motion; for supposing two men to set off at the same moment from A and B, ([fig. 2.](#)) to walk each to the end of their respective lines, C and D; if they perform their walk in the same space of time, they must have proceeded at a very different rate; and yet to an eye situated at E, they will appear to have moved with equal velocity, because they will both have gone through an equal number of degrees, though over a very unequal length of ground. The number of degrees over which a body moves in a given time, is called its angular velocity; two bodies, you see, may have the same angular, or apparent velocity, whilst their real velocities may differ almost infinitely. Sight is an extremely useful sense, no doubt, but it cannot always be relied on, it deceives us both in regard to the size and the distance of objects; indeed, our senses would be very liable to lead us into error, if experience did not set us right.

[Pg 171]

Emily. Between the two, I think that we contrive to acquire a tolerably accurate idea of objects.

Mrs. B. At least sufficiently so, for the general purposes of life. To convince you how requisite experience is, to correct the errors of sight, I shall relate to you, the case of a young man, who was blind from his infancy, and who recovered his sight at the age of fourteen, by the operation of couching. At first, he had no idea, either of the size, or distance of objects, but imagined that every thing he saw touched his eyes; and it was not, till after having repeatedly felt them, and walked from one object to another, that he acquired an idea of their respective dimensions, their relative situations, and their distances.

Caroline. The idea that objects touched his eyes, is, however, not so absurd, as it at first appears; for if we consider that we see only the image of objects, this image actually touches our eyes.

Mrs. B. That is, doubtless, the reason of the opinion he formed, before the sense of touch had corrected his judgment.

Caroline. But since an image must be formed on the retina of each of our eyes, why do we not see objects double?

Mrs. B. The action of the rays, on the optic nerve of each eye, is so perfectly similar, that they produce but a single sensation; the mind, therefore, receives the same idea, from the retina of both eyes, and conceives the object to be single.

Caroline. This is difficult to comprehend, and I should think, can be but conjectural.

Mrs. B. I can easily convince you, that you have a distinct image of an object formed on the retina of each eye. Look through the window, with both eyes open, at some object exactly opposite to one of the upright bars of the sash.

[Pg 172]

Caroline. I now see a tree, the body of which, appears to be in a line exactly opposite to one of the bars.

Mrs. B. If you now shut your right eye, and look with the left, it will appear to the left of the bar; then by closing the left eye, and looking with the other, it will appear to the right of the bar.

Caroline. That is true, indeed!

Mrs. B. There are, evidently, two representations of the tree in different situations, which must be owing to an image of it being formed on each eye; if the action of the rays, therefore, on each retina, were not so perfectly similar as to produce but one sensation, we should see double; and we find that to be the case with some persons, who are afflicted with a disease in one eye, which prevents the rays of light from affecting it in the same manner as the other.

Emily. Pray, Mrs. B., when we see the image of an object in a looking-glass, why is it not inverted, as in the camera obscura, and on the retina of the eye?

Mrs. B. Because the rays do not enter the mirror by a small aperture, and cross each other, as they do at the orifice of a camera obscura, or the pupil of the eye.

When you view yourself in a mirror, the rays from your eyes fall perpendicularly upon it, and are reflected in the same line; the image is, therefore, described behind the glass, and is situated in the same manner as the object before it.

Emily. Yes, I see that it is; but the looking-glass is not nearly so tall as I am, how is it, therefore, that I can see the whole of my figure in it?

Mrs. B. It is not necessary that the mirror should be more than half your height, in order that you may see the whole of your person in it, ([fig. 3.](#)) The ray of light A B, from your eye, which falls perpendicularly on the mirror B D, will be reflected back, in the same line; but the ray from your feet, will fall obliquely on the mirror, for it must ascend in order to reach it; it will, therefore, be reflected in the line A D: and since we view objects in the direction of the reflected rays, which reach the eye, and since the image appears at the same distance, behind the mirror, that the object is before it, we must continue the line A D to E, and the line C D to F, at the termination of which, the image will be represented.

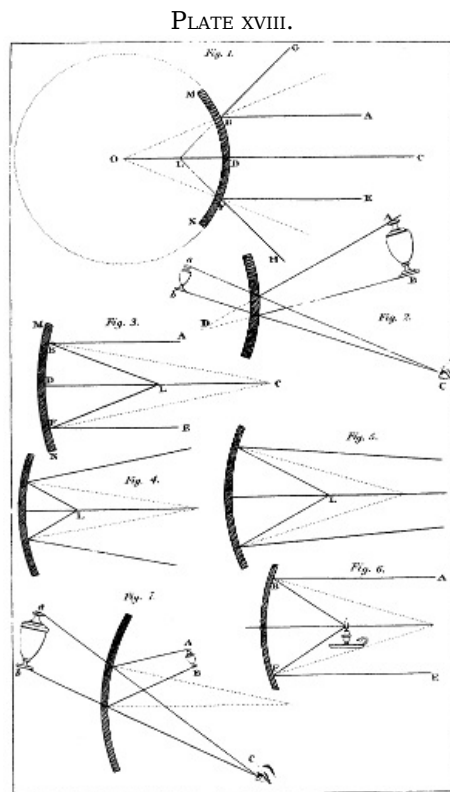

Emily. Then I do not understand why I should not see the whole of my person in a much smaller mirror, for a ray of light from my feet would always reach it, though more obliquely. [Pg 173]

Mrs. B. True; but the more obliquely the ray falls on the mirror, the more obliquely it will be reflected; the ray would, therefore, be reflected above your head, and you could not see it. This is shown by the dotted line ([fig. 3.](#))

Now stand a little to the right of the mirror, so that the rays of light from your figure may fall obliquely on it—

Emily. There is no image formed of me in the glass now.

Mrs. B. I beg your pardon, there is; but you cannot see it, because the incident rays, falling obliquely on the mirror, will be reflected obliquely, in the opposite direction; the angles of incidence, and reflection, being equal. Caroline, place yourself in the direction of the reflected rays, and tell me whether you do not see Emily's image in the glass?

Caroline. Let me consider.—In order to look in the direction of the reflected rays, I must place myself as much to the left of the glass, as Emily stands to the right of it.—Now I see her image, not straight before me, however, but before her; and it appears at the same distance behind the glass, that she is in front of it.

Mrs. B. You must recollect, that we always see objects in the direction of the last rays, which reach our eyes. [Figure 4](#) represents an eye, looking at the image of a vase, reflected by a mirror; it must see it in the direction of the ray A B, as that is the ray which brings the image to the eye; prolong the ray to C, and in that spot will the image appear.

Caroline. I do not understand why a looking-glass reflects the rays of light; for glass is a transparent body, which should transmit them!

Mrs. B. It is not the glass that reflects the rays which form the image you behold, but the silvering behind it; this silvering is a compound of mercury and tin, which forms a brilliant metallic coating. The glass acts chiefly as a transparent case, through which the rays find an easy passage, to, and from, the quicksilver.

Caroline. Why then should not mirrors be made simply of mercury?

Mrs. B. Because mercury is a fluid. By amalgamating it with tinfoil, it becomes of the consistence of paste, attaches itself to the glass, and forms, in fact, a metallic mirror, which would be much [Pg 174]

more perfect without its glass cover, for the purest glass is never perfectly transparent; some of the rays, therefore, are lost during their passage through it, by being either absorbed, or irregularly reflected.

This imperfection of glass mirrors, has introduced the use of metallic mirrors, for optical purposes.

Emily. But since all opaque bodies reflect the rays of light, I do not understand why they are not all mirrors.

Caroline. A curious idea indeed, sister; it would be very gratifying to see oneself in every object at which one looked.

Mrs. B. It is very true that all opaque objects reflect light; but the surface of bodies, in general, is so rough and uneven, that the reflection from them is extremely irregular, and prevents the rays from forming an image on the retina. This, you will be able to understand better, when I shall explain to you the nature of vision, and the structure of the eye.

You may easily conceive the variety of directions in which rays would be reflected by a nutmeg-grater, on account of the inequality of its surface, and the number of holes with which it is pierced. All solid bodies more or less resemble the nutmeg-grater, in these respects; and it is only those which are susceptible of receiving a polish, that can be made to reflect the rays with regularity. As hard bodies are of the closest texture, the least porous, and capable of taking the highest polish, they make the best mirrors; none, therefore, are so well calculated for this purpose, as metals.

Caroline. But the property of regular reflection, is not confined to this class of bodies; for I have often seen myself, in a highly polished mahogany table.

Mrs. B. Certainly; but as that substance is less durable, and its reflection less perfect, than that of metals, I believe it would seldom be chosen, for the purpose of a mirror.

There are three kinds of mirrors used in optics; the *plain*, or *flat*, which are the common mirrors we have just mentioned; *convex* mirrors, and *concave* mirrors. The reflection of the two latter, is very different from that of the former. The plain mirror, we have seen, does not alter the direction of the reflected rays, and forms an image behind the glass, exactly similar to the object before it. A convex mirror has the peculiar property of making the reflected rays diverge, by which means it diminishes the image; and a concave mirror makes the rays converge, and under certain circumstances, magnifies the image.

Emily. We have a convex mirror in the drawing-room, which forms a beautiful miniature picture of the objects in the room; and I have often amused myself with looking at my magnified face in a concave mirror. But I hope you will explain to us, why the one enlarges, while the other diminishes the objects it reflects. [Pg 175]

Mrs. B. Let us begin by examining the reflection of a convex mirror. This is formed of a portion of the exterior surface of a sphere. When several parallel rays fall upon it, that ray only which, if prolonged, would pass through the centre or axis of the mirror, is perpendicular to it. In order to avoid confusion, I have, in [fig. 1, plate 18](#), drawn only three parallel lines, A B, C D, E F, to represent rays falling on the convex mirror, M N; the middle ray, you will observe, is perpendicular to the mirror, the others fall on it, obliquely.

Caroline. As the three rays are parallel, why are they not all perpendicular to the mirror?

Mrs. B. They would be so to a flat mirror; but as this is spherical, no ray can fall perpendicularly upon it which is not directed towards the centre of the sphere.

Emily. Just as a weight falls perpendicularly to the earth, when gravity attracts it towards the centre.

Mrs. B. In order, therefore, that rays may fall perpendicularly to the mirror at B and F, the rays must be in the direction of the dotted lines, which, you may observe, meet at the centre O of the sphere, of which the mirror forms a portion.

Now, can you tell me in what direction the three rays, A B, C D, E F, will be reflected?

Emily. Yes, I think so: the middle ray, falling perpendicularly on the mirror, will be reflected in the same line: the two outer rays falling obliquely, will be reflected obliquely to G and H; for the dotted lines you have drawn are perpendiculars, which divide the angles of incidence and reflection, of those two rays.

Mrs. B. Extremely well, Emily: and since we see objects in the direction of the reflected ray, we shall see the image L, which is the point at which the reflected rays, if continued through the mirror, would unite and form an image. This point is equally distant, from the surface and centre of the sphere, and is called the imaginary focus of the mirror.

Caroline. Pray, what is the meaning of focus?

Mrs. B. A point at which converging rays, unite. And it is in this case, called an imaginary focus; because the rays do not really unite at that point, but only appear to do so: for the rays do not pass through the mirror, since they are reflected by it. [Pg 176]

Emily. I do not yet understand why an object appears smaller, when viewed in a convex mirror.

Mrs. B. It is owing to the divergence of the reflected rays. You have seen that a convex mirror, by reflection, converts parallel rays into divergent rays; rays that fall upon the mirror divergent, are rendered still more so by reflection, and convergent rays are reflected either parallel, or less convergent. If then, an object be placed before any part of a convex mirror, as the vase A B, [fig. 2](#), for instance, the two rays from its extremities, falling convergent on the mirror, will be reflected less convergent, and will not come to a focus, till they arrive at C; then an eye placed in the direction of the reflected rays, will see the image formed in (or rather behind) the mirror, at a *b*.

Caroline. But the reflected rays, do not appear to me to converge less than the incident rays. I should have supposed that, on the contrary, they converged more, since they meet in a point.

Mrs. B. They would unite sooner than they actually do, if they were not less convergent than the incident rays: for observe, that if the incident rays, instead of being reflected by the mirror, continued their course in their original direction, they would come to a focus at D, which is considerably nearer to the mirror than at C; the image, is, therefore, seen under a smaller angle than the object; and the more distant the latter is from the mirror, the smaller is the image reflected by it.

You will now easily understand the nature of the reflection of concave mirrors. These are formed of a portion of the internal surface of a hollow sphere, and their peculiar property is to converge the rays of light.

Can you discover, Caroline, in what direction the three parallel rays, A B, C D, E F, are reflected, which fall on the concave mirror, M N, ([fig. 3](#))?

Caroline. I believe I can. The middle ray is sent back in the same line, in which it arrives, that being the direction of the axis of the mirror; and the two others will be reflected obliquely, as they fall obliquely on the mirror. I must now draw two dotted lines perpendicular to their points of incidence, which will divide their angles of incidence and reflection; and in order that those angles may be equal, the two oblique rays must be reflected to L, where they will unite with the middle ray.

[Pg 177]

Mrs. B. Very well explained. Thus you see, that when any number of parallel rays fall on a concave mirror, they are all reflected to a focus: for in proportion as the rays are more distant from the axis of the mirror, they fall more obliquely upon it, and are more obliquely reflected; in consequence of which they come to a focus in the direction of the axis of the mirror, at a point equally distant from the centre, and the surface, of the sphere; and this point is not an imaginary focus, as happens with the convex mirror, but is the true focus at which the rays unite.

Emily. Can a mirror form more than one focus, by reflecting rays?

Mrs. B. Yes. If rays fall convergent on a concave mirror, ([fig. 4](#)) they are sooner brought to a focus, L, than parallel rays; their focus is, therefore, nearer to the mirror M N. Divergent rays are brought to a more distant focus than parallel rays, as in [figure 5](#), where the focus is at L; but what is called the true focus of mirrors, either convex or concave, is that of parallel rays, and is equally distant from the centre, and the surface of the spherical mirror.

I shall now show you the real reflection of rays of light, by a metallic concave mirror. This is one made of polished tin, which I expose to the sun, and as it shines bright, we shall be able to collect the rays into a very brilliant focus. I hold a piece of paper where I imagine the focus to be situated; you may see by the vivid spot of light on the paper, how much the rays converge: but it is not yet exactly in the focus; as I approach the paper to that point, observe how the brightness of the spot of light increases, while its size diminishes.

Caroline. That must be occasioned by the rays approaching closer together. I think you hold the paper just in the focus now, the light is so small and dazzling—Oh, Mrs. B., the paper has taken fire!

Mrs. B. The rays of light cannot be concentrated, without, at the same time, accumulating a proportional quantity of heat: hence concave mirrors have obtained the name of burning mirrors.

Emily. I have often heard of the surprising effects of burning mirrors, and I am quite delighted to understand their nature.

Caroline. It cannot be the true focus of the mirror, at which the rays of the sun unite, for as they proceed from so large a body, they cannot fall upon the mirror parallel to each other.

[Pg 178]

Mrs. B. Strictly speaking, they certainly do not. But when rays, come from such an immense distance as the sun, they may be considered as parallel: their point of union is, therefore, the true focus of the mirror, and there the image of the object is represented.

Now that I have removed the mirror out of the influence of the sun's rays, if I place a burning taper in the focus, how will its light be reflected? ([Fig. 6](#).)

Caroline. That, I confess, I cannot say.

Mrs. B. The ray which falls in the direction of the axis of the mirror, is reflected back in the same line; but let us draw two other rays from the focus, falling on the mirror at B and F; the dotted

lines are perpendicular to those points, and the two rays will, therefore, be reflected to A and E.

Caroline. Oh, now I understand it clearly. The rays which proceed from a light placed in the focus of a concave mirror fall divergent upon it, and are reflected, parallel. It is exactly the reverse of the former experiment, in which the sun's rays fell parallel on the mirror, and were reflected to a focus.

Mrs. B. Yes: when the incident rays are parallel, the reflected rays converge to a focus; when, on the contrary, the incident rays proceed from the focus, they are reflected parallel. This is an important law of optics, and since you are now acquainted with the principles on which it is founded, I hope that you will not forget it.

Caroline. I am sure that we shall not. But, Mrs. B., you said that the image was formed in the focus of a concave mirror; yet I have frequently seen glass concave mirrors, where the object has been represented within the mirror, in the same manner as in a convex mirror.

Mrs. B. That is the case only, when the object is placed between the mirror and its focus; the image then appears magnified behind the mirror, or, as you would say, within it.

Caroline. I do not understand why the image should be larger than the object.

Mrs. B. This results from the convergent property of the concave mirror. If an object, A B, ([fig. 7.](#)) be placed between the mirror and its focus, the rays from its extremities fall divergent on the mirror, and on being reflected, become less divergent, as if they proceeded from C: to an eye placed in that situation, the image will appear magnified behind the mirror at *a b*, since it is seen under a larger angle than the object.

[Pg 179]

You now, I hope, understand the reflection of light by opaque bodies. At our next meeting, we shall enter upon another property of light, no less interesting, and which is called *refraction*.

Questions

1. (Pg. [168](#)) What is meant by the angle of vision, or the visual angle?
2. (Pg. [169](#)) Why do objects of the same size appear smaller when distant, than when near?
3. (Pg. [169](#)) Why do not two objects, known to be equal in size, appear to differ, when at different distances from the eye?
4. (Pg. [169](#)) How is this exemplified, by a house seen through a window?
5. (Pg. [170](#)) Why do rows of trees, forming an avenue, appear to approach as they recede from the eye, until they eventually seem to meet?
6. (Pg. [170](#)) In drawing a view from nature, what do we copy?
7. (Pg. [170](#)) What is the difference in sculpture, in this respect?
8. (Pg. [170](#)) Excepting the rays from an object enter the eye, under a certain angle, they cannot be seen; what must this angle exceed?
9. (Pg. [170](#)) What two circumstances may cause the angle to be so small, as not to produce vision?
10. (Pg. [170](#)) Motion may be so slow as to become imperceptible, what is said on this point?
11. (Pg. [170](#)) Under what circumstances may a body, moving with great rapidity, appear to be at rest?
12. (Pg. [170](#)) Upon what does the real velocity of a body, depend?
13. (Pg. [171](#)) What must be known, to enable us to ascertain the real space contained in a degree?
14. (Pg. [171](#)) What is explained by [fig. 2, plate 17](#)?
15. (Pg. [171](#)) What is said respecting the evidence afforded by our senses, and how do we correct the errors into which they would lead us?
16. (Pg. [171](#)) An image of a visible object is formed upon the retina of each eye, why, therefore, are not objects seen double?
17. (Pg. [172](#)) By what experiment can you prove that a separate image of an object is formed in each eye?
18. (Pg. [172](#)) Under what circumstances are objects seen double?
19. (Pg. [172](#)) Why is not the image of an object inverted in the common mirror?
20. (Pg. [172](#)) Your whole figure may be seen in a looking-glass, which is not more than half your height; how is this shown in [fig. 3, plate 17](#)?
21. (Pg. [173](#)) Why is the image invisible to the person, when not standing directly before the glass?
22. (Pg. [173](#)) In what situation may a second person see the image reflected?
23. (Pg. [173](#)) In what direction will an object always appear to the eye?
24. (Pg. [173](#)) How is this explained by [fig. 4, plate 17](#)?
25. (Pg. [173](#)) What is it that reflects the rays in a looking-glass?
26. (Pg. [174](#)) All opaque bodies reflect some light, why do they not all act as mirrors?
27. (Pg. [174](#)) What substances form the most perfect mirrors, and for what reason?
28. (Pg. [174](#)) What are the three kinds of mirrors usually employed for optical purposes?
29. (Pg. [174](#)) How are the rays of light affected by them?
30. (Pg. [175](#)) What is the form of a convex mirror, and how do parallel rays fall upon it, as represented in [fig. 1, plate 18](#)?
31. (Pg. [175](#)) What is represented by the dotted line in the same figure?
32. (Pg. [175](#)) Explain by the figure, how the parallel rays will be reflected.
33. (Pg. [175](#)) At what distance behind such a mirror, would an image, produced by parallel rays, be formed?
34. (Pg. [175](#)) What is that point denominated?
35. (Pg. [176](#)) What is meant by a focus?
36. (Pg. [176](#)) Why is the point behind the mirror, called the *imaginary focus*?
37. (Pg. [176](#)) Why does an object appear to be lessened by a convex mirror, ([fig. 2.](#))?
38. (Pg. [176](#)) What is a concave mirror, and what its peculiar property?

39. (Pg. [176](#)) How are parallel rays reflected by a concave mirror, as explained by [fig. 3, plate 18](#)?
40. (Pg. [177](#)) Where is the focus of parallel rays, in a concave mirror?
41. (Pg. [177](#)) If rays fall on it convergent, how are they reflected?
42. (Pg. [177](#)) How if divergent?
43. (Pg. [177](#)) How, and why, may concave, become burning mirrors?
44. (Pg. [178](#)) Why may rays of light coming from the sun, be viewed as parallel to each other?
45. (Pg. [178](#)) If a luminous body, as a burning taper, be placed in the focus of a concave mirror, how will the rays from it, be reflected? ([fig. 6.](#))
46. (Pg. [178](#)) What fact is explained by [fig. 7, plate 18](#)?

CONVERSATION XVI. ON REFRACTION AND COLOURS.

TRANSMISSION OF LIGHT BY TRANSPARENT BODIES. REFRACTION. REFRACTION BY THE ATMOSPHERE. REFRACTION BY A LENS. REFRACTION BY THE PRISM. OF COLOUR FROM THE RAYS OF LIGHT. OF THE COLOURS OF BODIES.

MRS. B.

The refraction of light will furnish the subject of to-day's lesson.

Caroline. That is a property of which I have not the faintest idea.

Mrs. B. It is the effect which transparent mediums produce on light in its passage through them. Opaque bodies, you know, reflect the rays, and transparent bodies transmit them; but it is found, that *if a ray, in passing from one medium, into another of different density, fall obliquely, it is turned out of its course. The ray of light is then said to be refracted.*

Caroline. It must then be acted on by some new power, otherwise it would not deviate from its first direction.

Mrs. B. The power which causes the deviation of the ray, appears to be the attraction of the denser medium. Let us suppose the two mediums to be air, and water; if a ray of light passes from air, into water, it is more strongly attracted by the latter, on account of its superior density.

Emily. In what direction does the water attract the ray?

Mrs. B. The ray is attracted perpendicularly towards the water, in the same manner in which bodies are acted upon by gravity. [Pg 180]

If then a ray, A B, ([fig. 1, plate 19.](#)) fall perpendicularly on water, the attraction of the water acts in the same direction as the course of the ray: it will not, therefore, cause a deviation, and the ray will proceed straight on, to E. But if it fall obliquely, as the ray C B, the water will attract it out of its course. Let us suppose the ray to have approached the surface of a denser medium, and that it there begins to be affected by its attraction; this attraction, if not counteracted by some other power, would draw it perpendicularly to the water, at B; but it is also impelled by its projectile force, which the attraction of the denser medium cannot overcome; the ray, therefore, acted on by both these powers, moves in a direction between them, and instead of pursuing its original course to D, or being implicitly guided by the water to E, proceeds towards F, so that the ray appears bent or broken.

Caroline. I understand that very well; and is not this the reason that oars appear bent in the water?

Mrs. B. It is owing to the refraction of the rays, reflected by the oar; but this is in passing from a dense, to a rare medium, for you know that the rays, by means of which you see the oar, pass from water into air.

Emily. But I do not understand why refraction takes place, when a ray passes from a dense into a rare medium; I should suppose that it would be less, attracted by the latter, than by the former.

Mrs. B. And it is precisely on that account that the ray is refracted. Let the upper half of [fig. 2,](#) represent glass, and the lower half water, let C B represent a ray, passing obliquely from the glass, into water: glass, being the denser medium, the ray will be more strongly attracted by that which it leaves than by that which it enters. The attraction of the glass acts in the direction A B, while the impulse of projection would carry the ray to F; it moves, therefore, between these directions towards D.

Emily. So that a contrary refraction takes place, when a ray passes from a dense, into a rare medium.

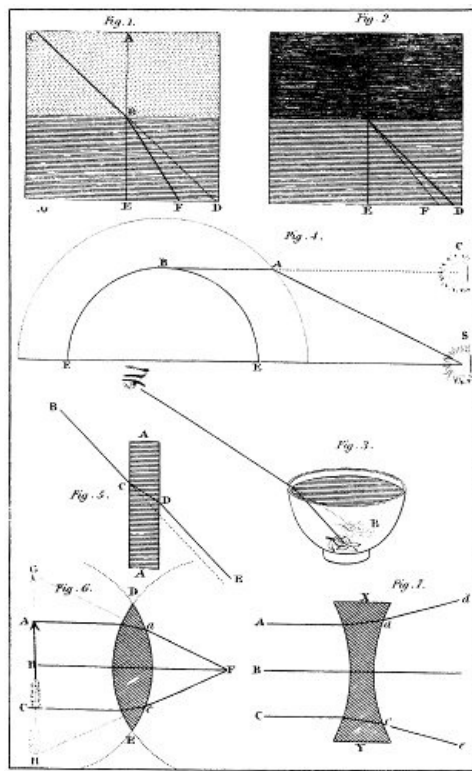

Mrs. B. The rule upon this subject is this; when a ray of light passes from a rare into a dense medium, it is refracted towards the perpendicular; when from a dense into a rare medium, it is refracted from the perpendicular. By the perpendicular is meant a line, at right angle with the refracting surface. This may be seen in [fig. 1](#), and [fig. 2](#), where the lines A E, are the perpendiculars.

[Pg 181]

Caroline. But does not the attraction of the denser medium affect the ray before it touches it?

Mrs. B. The distance at which the attraction of the denser medium acts upon a ray, is so small, as to be insensible; it appears, therefore, to be refracted only at the point at which it passes from one medium into the other.

Now that you understand the principle of refraction, I will show you the real refraction of a ray of light. Do you see the flower painted at the bottom of the inside of this tea-cup? ([Fig. 3](#).)

Emily. Yes.—But now you have moved it just out of sight; the rim of the cup hides it.

Mrs. B. Do not stir. I will fill the cup with water, and you will see the flower again.

Emily. I do, indeed! Let me try to explain this: when you drew the cup from me, so as to conceal the flower, the rays reflected by it, no longer met my eyes, but were directed above them; but now that you have filled the cup with water, they are refracted, and bent downwards when passing out of the water, into the air, so as again to enter my eyes.

Mrs. B. You have explained it perfectly: [fig. 3](#). will help to imprint it on your memory. You must observe that when the flower becomes visible by the refraction of the ray, you do not see it in the situation which it really occupies, but the image of the flower appears higher in the cup; for as objects always appear to be situated in the direction of the rays which enter the eye, the flower will be seen at B, in the direction of the refracted ray.

Emily. Then, when we see the bottom of a clear stream of water, the rays which it reflects, being refracted in their passage from the water into the air, will make the bottom appear higher than it really is.

Mrs. B. And the water will consequently appear more shallow. Accidents have frequently been occasioned by this circumstance; and boys, who are in the habit of bathing, should be cautioned not to trust to the apparent shallowness of water, as it will always prove deeper than it appears.

The refraction of light prevents our seeing the heavenly bodies in their real situation: the light they send to us being refracted in passing into the atmosphere, we see the sun and stars in the direction of the refracted ray; as described in [fig. 4](#), [plate 19](#), the dotted line represents the extent of the atmosphere, above a portion of the earth, E B E: a ray of light coming from the sun S, falls obliquely on it, at A, and is refracted to B; then, since we see the object in the direction of the refracted ray, a spectator at B, will see an image of the sun at C, instead of its real situation, at S.

[Pg 182]

Emily. But if the sun were immediately over our heads, its rays, falling perpendicularly on the atmosphere, would not be refracted, and we should then see the real sun, in its true situation.

Mrs. B. You must recollect that the sun, is vertical only to the inhabitants of the torrid zone; its rays, therefore, are always refracted, in this latitude. There is also another obstacle to our seeing the heavenly bodies in their real situations: light, though it moves with extreme velocity, is about

eight minutes and a quarter, in its passage from the sun to the earth; therefore, when the rays reach us, the sun must have quitted the spot he occupied on their departure; yet we see him in the direction of those rays, and consequently in a situation which he had abandoned eight minutes and a quarter, before.

Emily. When you speak of the sun's motion, you mean, I suppose, his apparent motion, produced by the diurnal motion of the earth?

Mrs. B. Certainly; the effect being the same, whether it is our earth, or the heavenly bodies, which move: it is more easy to represent things as they appear to be, than as they really are.

Caroline. During the morning, then, when the sun is rising towards the meridian, we must (from the length of time the light is in reaching us) see an image of the sun below that spot which it really occupies.

Emily. But the refraction of the atmosphere, counteracting this effect, we may, perhaps, between the two, see the sun in its real situation.

Caroline. And in the afternoon, when the sun is sinking in the west, refraction, and the length of time which the light is in reaching the earth, will conspire to render the image of the sun, higher than it really is.

Mrs. B. The refraction of the sun's rays, by the atmosphere, prolongs our days, as it occasions our seeing an image of the sun, both before he rises, and after he sets; when below our horizon, he still shines upon the atmosphere, and his rays are thence refracted to the earth: so likewise we see an image of the sun, previously to his rising, the rays that fall upon the atmosphere being refracted to the earth.

[Pg 183]

Caroline. On the other hand, we must recollect that light is eight minutes and a quarter on its journey; so that, by the time it reaches the earth, the sun may, perhaps, have risen above the horizon.

Emily. Pray, do not glass windows, refract the light?

Mrs. B. They do; but this refraction would not be perceptible, were the surfaces of the glass, perfectly flat and parallel, because, in passing through a pane of glass, the rays suffer two refractions, which, being in contrary directions, produce nearly the same effect as if no refraction had taken place.

Emily. I do not understand that.

Mrs. B. [Fig. 5, plate 19](#), will make it clear to you: A A represents a thick pane of glass, seen edgewise. When the ray B approaches the glass, at C, it is refracted by it; and instead of continuing its course in the same direction, as the dotted line describes, it passes through the pane, to D; at that point returning into the air, it is again refracted by the glass, but in a contrary direction to the first refraction, and in consequence proceeds to E. Now you must observe that the ray B C and the ray D E being parallel, the light does not appear to have suffered any refraction: the apparent, differing so little from the true place of any object, when seen through glass of ordinary thickness.

Emily. So that the effect which takes place on the ray entering the glass, is undone on its quitting it. Or, to express myself more scientifically, when a ray of light passes from one medium into another, and through that into the first again, the two refractions being equal, and in opposite directions, no sensible effect is produced.

Caroline. I think the effect is very sensible, for, in looking through the glass of the window, I see objects very much distorted; articles which I know to be straight, appear bent and broken, and sometimes the parts seem to be separated to a distance from each other.

Mrs. B. That is because common window glass is not flat, its whole surface being uneven. Rays from any object, falling upon it under different angles, are, consequently, refracted in various ways, and thus produce the distortion you have observed.

Emily. Is it not in consequence of refraction, that the glasses in common spectacles, magnify objects seen through them?

Mrs. B. Yes. Glasses of this description are called *lenses*; of these, there are several kinds, the names of which it will be necessary for you to learn. Every lens is formed of glass, ground so as to form a segment of a sphere, on one, or both sides. They are all represented at [fig. 1, plate 20](#). The most common, is the *double convex* lens, D. This is thick in the middle, and thin at the edges, like common spectacles, or reading glasses. A B, is a *plano-convex* lens, being flat on one side, and convex on the other. E is a *double concave*, being, in all respects, the reverse of D. C is a *plano-concave*, flat on one side, and concave on the other. F is called a *meniscus*, or *concavo-convex*, being concave on one, and convex on the other side. A line passing through the centre of a lens, is called its *axis*.

[Pg 184]

Caroline. I should like to understand how the rays of light are refracted, by means of a lens.

Mrs. B. When parallel rays ([fig. 6](#)) fall on a double convex *lens*, that only, which falls in the direction of the axis of the lens, is perpendicular to the surface; the other rays, falling obliquely, are refracted towards the axis, and will meet at a point beyond the lens, called its *focus*.

Of the three rays, A B C, which fall on the lens D E, the rays A and C are refracted in their passage through it, to *a*, and *c*; and on quitting the lens, they undergo a second refraction in the same direction, which unites them with the ray B, at the focus F.

Emily. And what is the distance of the focus, from the surface of the lens?

Mrs. B. The focal distance depends both upon the form of the lens, and on the refracting power of the substance of which it is made: in a glass lens, both sides of which are equally convex, the focus is situated nearly at the centre of the sphere, of which the surface of the lens forms a portion; it is at the distance, therefore, of the radius of the sphere.

The property of those lenses which have a convex surface, is to collect the rays of light to a focus; and of those which have a concave surface, on the contrary, to disperse them. For the rays A and C, falling on the concave lens X Y, ([fig. 7, plate 19.](#)) instead of converging towards the ray B, in the axis of the lens, will each be attracted towards the thick edges of the lens, both on entering and quitting it, and will, therefore, by the first refraction, be made to diverge to *a*, *c*, and by the seconds, to *d*, *e*.

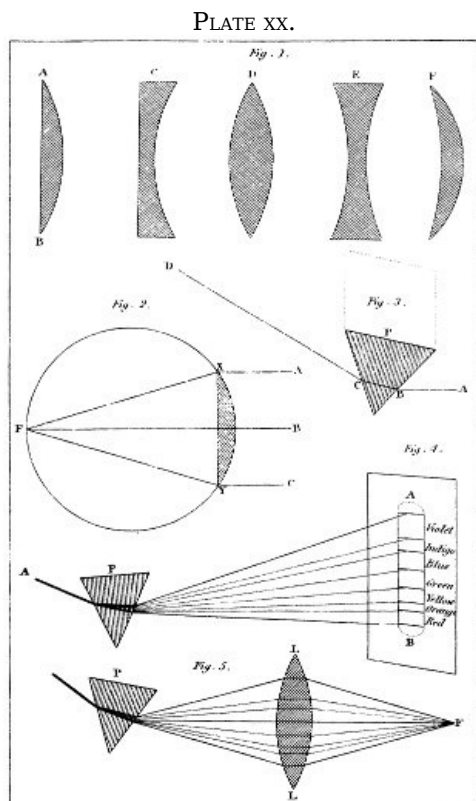

Caroline. And lenses which have one side flat, and the other convex, or concave, as A and B, ([fig. 1, plate 20.](#)) are, I suppose, less powerful in their refractions? [Pg 185]

Mrs. B. Yes; the focus of the plano-convex, is at the distance of the diameter of a sphere, of which the convex surface of the lens, forms a portion; as represented in [figure 2, plate 20.](#) The three parallel rays, A B C, are brought to a focus by the plano-convex lens, X Y, at F.

Emily. You have not explained to us, Mrs. B., how the lens serves to magnify objects.

Mrs. B. By turning again to [fig. 6, plate 19.](#) you will readily understand this. Let A C, be an object placed before the lens, and suppose it to be seen by an eye at F; the ray from the point A, will be seen in the direction F G, that from C, in the direction F H; the visual angle, therefore, will be greatly increased, and the object must appear larger, in proportion.

I must now explain to you the refraction of a ray of light, by a triangular piece of glass, called a prism. ([Fig. 3.](#))

Emily. The three sides of this glass are flat; it cannot, therefore, bring the rays to a focus; nor do I suppose that its refraction will be similar to that of a flat pane of glass, because it has not two sides parallel; I cannot, therefore, conjecture what effect the refraction by a prism, can produce.

Mrs. B. The refractions of the ray, both on entering and on quitting the prism, are in the same direction, ([Fig. 3.](#)) On entering the prism P, the ray A is refracted from B to C, and on quitting it from C to D. In the first instance it is refracted towards, and in the last, from the perpendicular; each causing it to deviate in the same way, from its original course, A B.

I will show you this by experiment; but for this purpose it will be advisable to close the window-shutters, and admit, through the small aperture, a ray of light, which I shall refract, by means of this prism.

Caroline. Oh, what beautiful colours are represented on the opposite wall! There are all the colours of the rainbow, and with a brightness, I never saw equalled. ([Fig. 4, plate 20.](#))

Emily. I have seen an effect, in some respects similar to this, produced by the rays of the sun shining upon glass lustres; but how is it possible that a piece of white glass can produce such a variety of brilliant colours?

Mrs. B. The colours are not formed by the prism, but existed in the ray previously to its refraction.

Caroline. Yet, before its refraction, it appeared perfectly white.

[Pg 186]

Mrs. B. The white rays of the sun, are composed of rays, which, when separated, produce all these colours, although when blended together, they appear colourless or white.

Sir Isaac Newton, to whom we are indebted for the most important discoveries respecting light and colours, was the first who divided a white ray of light, and found it to consist of an assemblage of coloured rays, which formed an image upon the wall, such as you now see exhibited, ([fig. 4.](#)) in which are displayed the following series of colours: red, orange, yellow, green, blue, indigo, and violet.

Emily. But how does a prism separate these coloured rays?

Mrs. B. By refraction. It appears that the coloured rays have different degrees of refrangibility; in passing through the prism, therefore, they take different directions according to their susceptibility of refraction. The violet rays deviate most from their original course; they appear at one of the ends of the spectrum, A B: contiguous to the violet, are the blue rays, being those which have somewhat less refrangibility; then follow, in succession, the green, yellow, orange, and lastly, the red, which are the least refrangible of the coloured rays.

Caroline. I cannot conceive how these colours, mixed together, can become white?

Mrs. B. That I cannot pretend to explain: but it is a fact that the union of these colours, in the proportions in which they appear in the spectrum, produce in us the idea of whiteness. If you paint a circular piece of card, in compartments, with these seven colours, as nearly as possible in the proportion, and of the shade exhibited in the spectrum, and whirl it rapidly on a pin, it will appear white; as the velocity of the motion, will have the effect of blending the colours, in the impression which they make upon the eye.

But a more decisive proof of the composition of a white ray is afforded, by reuniting these coloured rays, and forming with them, a ray of white light.

Caroline. If you can take a ray of white light to pieces, and put it together again, I shall be quite satisfied.

Mrs. B. This can be done by letting the coloured rays, which have been separated by a prism, fall upon a lens, which will converge them to a focus; and if, when thus reunited, we find that they appear white as they did before refraction, I hope you will be convinced that the white rays, are a compound of the several coloured rays. The prism P, you see, ([fig. 5.](#)) separates a ray of white light, into seven coloured rays, and the lens L L brings them to a focus at F, where they again appear white.

[Pg 187]

Caroline. You succeed to perfection: this is indeed a most interesting and conclusive experiment.

Emily. Yet, Mrs. B., I cannot help thinking, that there may, perhaps, be but three distinct colours in the spectrum, red, yellow, and blue; and that the four others may consist of two of these colours blended together; for, in painting, we find, that by mixing red and yellow, we produce orange; with different proportions of red and blue, we make violet or any shade of purple; and yellow, and blue, form green. Now, it is very natural to suppose, that the refraction of a prism, may not be so perfect as to separate the coloured rays of light completely, and that those which are contiguous, in order of refrangibility, may encroach on each other, and by mixing, produce the intermediate colours, orange, green, violet, and indigo.

Mrs. B. Your observation is, I believe, neither quite wrong, nor quite right. Dr. Wollaston, who has performed many experiments on the refraction of light, in a more accurate manner than had been previously done, by receiving a very narrow line of light on a prism, found that it formed a spectrum, consisting of rays of four colours only; but they were not exactly those you have named as primitive colours, for they consisted of red, green, blue, and violet. A very narrow line of yellow was visible, at the limit of the red and green, which Dr. Wollaston attributed to the overlapping of the edges of the red and green light.

Caroline. But red and green mixed together, do not produce yellow?

Mrs. B. Not in painting; but it may be so in the primitive rays of the spectrum. Dr. Wollaston observed, that, by increasing the breadth of the aperture, by which the line of light was admitted, the space occupied by each coloured ray in the spectrum, was augmented, in proportion as each portion encroached on the neighbouring colour, and mixed with it; so that the intervention of orange and yellow, between the red and green, is owing, he supposes, to the mixture of these two colours; and the blue is blended on the one side with the green, and on the other with the violet, forming the spectrum, as it was originally observed by Sir Isaac Newton, and which I have just shown you.

The rainbow, which exhibits a series of colours, so analogous to those of the spectrum, is formed by the refraction of the sun's rays, in their passage through a shower of rain; every drop of which

[Pg 188]

acts as a prism, in separating the coloured rays as they pass through it; the combined effect of innumerable drops, produces the bow, which you know can be seen, only when there are both rain, and sunshine.

Emily. Pray, Mrs. B., cannot the sun's rays be collected to a focus by a lens, in the same manner as they are by a concave mirror?

Mrs. B. The same effect in concentrating the rays, is produced by the refraction with a lens, as by the reflection from a concave mirror: in the first, the rays pass through the glass and converge to a focus, behind it, in the latter, they are reflected from the mirror, and brought to a focus, before it. A lens, when used for the purpose of collecting the sun's rays, is called a burning glass. I have before explained to you, the manner in which a convex lens, refracts the rays, and brings them to a focus; ([fig. 6, plate 19.](#)) as these rays contain both light and heat, the latter, as well as the former, is refracted; and intense heat, as well as light, will be found in the focal point. The sun now shines very bright; if we let the rays fall on this lens, you will perceive the focus.

Emily. Oh yes: the point of union of the rays, is very luminous. I will hold a piece of paper in the focus, and see if it will take fire. The spot of light is extremely brilliant, but the paper does not burn?

Mrs. B. Try a piece of brown paper;—that, you see, takes fire almost immediately.

Caroline. This is surprising; for the light appeared to shine more intensely, on the white, than on the brown paper.

Mrs. B. The lens collects an equal number of rays to a focus, whether you hold the white or the brown paper, there; but the white paper appears more luminous in the focus, because most of the rays, instead of entering into the paper, are reflected by it; and this is the reason that the paper does not readily take fire: whilst, on the contrary, the brown paper, which absorbs more light and heat than it reflects, soon becomes heated and takes fire.

Caroline. This is extremely curious; but why should brown paper, absorb more rays, than white paper?

Mrs. B. I am far from being able to give a satisfactory answer to that question. We can form but mere conjecture on this point; it is supposed that the tendency to absorb, or reflect rays, depends on the arrangement of the minute particles of the body, and that this diversity of arrangement renders some bodies susceptible of reflecting one coloured ray, and absorbing the others; whilst other bodies, have a tendency to reflect all the colours, and others again, to absorb them all.

[Pg 189]

Emily. And how do you know which colours bodies have a tendency to reflect, or which to absorb?

Mrs. B. Because a body always appears to be of the colour which it reflects; for, as we see only by reflected rays, it can appear of the colour of those rays, only.

Caroline. But we see all bodies of their own natural colour, Mrs. B.; the grass and trees, green; the sky, blue; the flowers of various hues.

Mrs. B. True; but why is the grass green?—because it absorbs all, except the green rays; it is, therefore, these only which the grass and trees reflect to our eyes, and this makes them appear green. The flowers, in the same manner, reflect the various colours of which they appear to us; the rose, the red rays; the violet, the blue; the jonquil, the yellow, &c.

Caroline. But these are the permanent colours of the grass and flowers, whether the sun's rays shine on them or not.

Mrs. B. Whenever you see those colours, the flowers must be illumined by some light; and light, from whatever source it proceeds, is of the same nature; composed of the various coloured rays which paint the grass, the flowers, and every coloured object in nature.

Caroline. But, Mrs. B., the grass is green, and the flowers are coloured, whether in the dark, or exposed to the light?

Mrs. B. Why should you think so?

Caroline. It cannot be otherwise.

Mrs. B. A most philosophical reason indeed! But, as I never saw them in the dark, you will allow me to dissent from your opinion.

Caroline. What colour do you suppose them to be, then, in the dark?

Mrs. B. None at all; or black, which is the same thing. You can never see objects, without light. White light is compounded of rays, from which all the colours in nature are produced; there, therefore, can be no colour without light; and though a substance is black, or without colour, in the dark, it may become coloured, as soon as it becomes visible. It is visible, indeed, only by the coloured rays which it reflects; therefore, we can see it only when coloured.

Caroline. All you say seems very true, and I know not what to object to it; yet it appears at the same time incredible! What, Mrs. B., are we all as black as negroes in the dark? you make me shudder at the thought.

[Pg 190]

Mrs. B. Your vanity need not be alarmed at the idea, as you are certain of never being seen, in that state.

Caroline. That is some consolation, undoubtedly; but what a melancholy reflection it is, that all nature which appears so beautifully diversified with colours, is really one uniform mass of blackness!

Mrs. B. Is nature less pleasing for being coloured, as well as illumined, by the rays of light? and are colours less beautiful, for being accidental, rather than essential properties of bodies?

Providence seems to have decorated nature with the enchanting diversity of colours, which we so much admire, for the sole purpose of beautifying the scene, and rendering it a source of sensible gratification: it is an ornament which embellishes nature, whenever we behold her. What reason is there to regret, that she does not wear it when she is invisible?

Emily. I confess, Mrs. B., that I have had my doubts, as well as Caroline, though she has spared me the pains of expressing them: but I have just thought of an experiment, which, if it succeed, will, I am sure, satisfy us both. It is certain, that we cannot see bodies in the dark, to know whether they have then any colour. But we may place a coloured body in a ray of light, which has been refracted by a prism; and if your theory is true, the body, of whatever colour it naturally is, must appear of the colour of the ray in which it is placed; for since it receives no other coloured rays, it can reflect no others.

Caroline. Oh! that is an excellent thought, Emily; will you stand the test, Mrs. B.?

Mrs. B. I consent: but we must darken the room, and admit only the ray which is to be refracted; otherwise, the white rays will be reflected on the body under trial, from various parts of the room. With what do you choose to make the experiment?

Caroline. This rose: look at it, Mrs. B., and tell me whether it is possible to deprive it of its beautiful colour?

Mrs. B. We shall see.—I expose it first to the red rays, and the flower appears of a more brilliant hue; but observe the green leaves——

Caroline. They appear neither red nor green; but of a dingy brown with a reddish glow?

Mrs. B. They cannot appear green, because they have no green rays to reflect; neither are they red, because green bodies absorb most of the red rays. But though bodies, from the arrangement of their particles, have a tendency to absorb some rays, and reflect others, yet it is not natural to suppose, that bodies are so perfectly uniform in their arrangement, as to reflect only pure rays of one colour, and perfectly to absorb the others; it is found, on the contrary, that a body reflects, in great abundance, the rays which determine its colour, and the others in a greater or less degree, in proportion as they are nearer to or further from its own colour, in the order of refrangibility. The green leaves of the rose, therefore, will reflect a few of the red rays, which, blended with their natural blackness, give them that brown tinge: if they reflected none of the red rays, they would appear perfectly black. Now I shall hold the rose in the blue rays——

[Pg 191]

Caroline. Oh, Emily, Mrs. B. is right! look at the rose: it is no longer red, but of a dingy blue colour.

Emily. This is the most wonderful, of any thing we have yet learnt. But, Mrs. B., what is the reason that the green leaves, are of a brighter blue than the rose?

Mrs. B. The green leaves reflect both blue and yellow rays, which produce a green colour. They are now in a coloured ray, which they have a tendency to reflect; they, therefore, reflect more of the blue rays than the rose, (which naturally absorbs that colour,) and will, of course, appear of a brighter blue.

Emily. Yet, in passing the rose through the different colours of the spectrum, the flower takes them more readily than the leaves.

Mrs. B. Because the flower is of a paler hue. Bodies which reflect all the rays, are white; those which absorb them all, are black: between these extremes, bodies appear lighter or darker, in proportion to the quantity of rays they reflect or absorb. This rose is of a pale red; it approaches nearer to white than to black, and therefore, reflects rays, more abundantly than it absorbs them.

Emily. But if a rose has so strong a tendency to reflect rays, I should imagine that it would be of a deep red colour.

Mrs. B. I mean to say, that it has a general tendency to reflect rays. Pale coloured bodies, reflect all the coloured rays to a certain degree, their paleness, being an approach towards whiteness: but they reflect one colour more than the rest: this predominates over the white, and determines the colour of the body. Since, then, bodies of a pale colour, in some degree reflect all the rays of light, in passing through the various colours of the spectrum, they will reflect them all, with tolerable brilliancy; but will appear most vivid, in the ray of their natural colour. The green leaves, on the contrary, are of a dark colour, bearing a stronger resemblance to black, than to white; they have, therefore, a greater tendency to absorb, than to reflect rays; and reflecting very few of any, but the blue, and yellow rays, they will appear dingy, in passing through the other colours of the spectrum.

[Pg 192]

Caroline. They must, however, reflect great quantities of the green rays, to produce so deep a colour.

Mrs. B. Deepness or darkness of colour, proceeds rather from a deficiency, than an abundance of reflected rays. Remember, that if bodies reflected none of the rays, they would be black; and if a body reflects only a few green rays, it will appear of a dark green; it is the brightness, and intensity of the colour, which show that a great quantity of rays are reflected.

Emily. A white body, then, which reflects all the rays, will appear equally bright in all the colours of the spectrum.

Mrs. B. Certainly. And this is easily proved by passing a sheet of white paper, through the rays of the spectrum.

White, you perceive, results from a body reflecting all the rays which fall upon it; black, is produced, when they are all absorbed; and colour, arises from a body possessing the power to decompose the solar ray, by absorbing some parts, and reflecting others.

Caroline. What is the reason that articles which are blue, often appear green, by candle-light?

Mrs. B. The light of a candle, is not of so pure a white as that of the sun: it has a yellowish tinge, and when refracted by the prism, the yellow rays predominate; and blue bodies reflect some of the yellow rays, from their being next to the blue, in the order of refrangibility; the superabundance of yellow rays, which is supplied by the candle, gives to blue bodies, a greenish hue.

Caroline. Candle-light must then give to all bodies, a yellowish tinge, from the excess of yellow rays; and yet it is a common remark, that people of a sallow complexion, appear fairer, or whiter, by candle-light.

Mrs. B. The yellow cast of their complexion is not so striking, when every surrounding object has a yellow tinge.

Emily. Pray, why does the sun appear red, through a fog?

PLATE XXI.

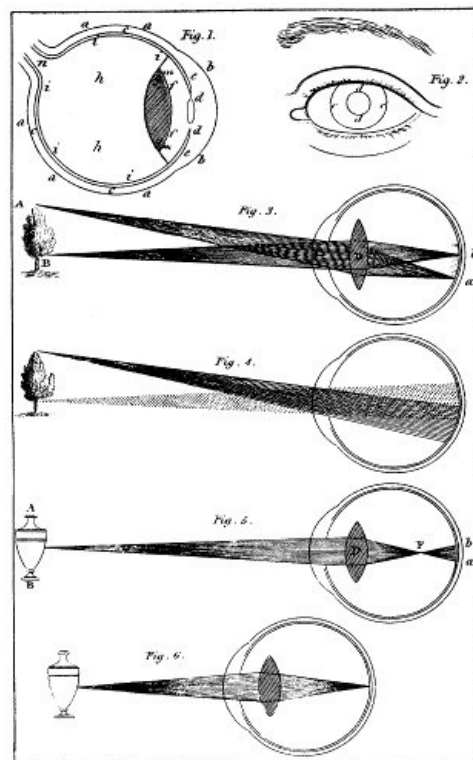

Mrs. B. It is supposed to be owing to the rays, which are most refrangible, being also the most easily reflected: in passing through an atmosphere, loaded with moisture, as in foggy weather, and also in the morning and evening, when mists prevail, the *violet, indigo, blue, and green* rays, are reflected back by the particles which load the air; whilst the *yellow, orange, and red* rays, being less susceptible of reflection, pass on, and reach the eye. [Pg 193]

Caroline. And, pray, why is the sky of a blue colour?

Mrs. B. You should rather say, the atmosphere; for the sky is a very vague term, the meaning of which, it would be difficult to define, philosophically.

Caroline. But the colour of the atmosphere should be white, since all the rays traverse it, in their passage to the earth.

Mrs. B. Do not forget that the direct rays of light which pass from the sun to the earth, do not meet our eyes, excepting when we are looking at that luminary, and thus intercept them; in which case, you know, that the sun appears white. The atmosphere is a transparent medium,

through which the sun's rays pass freely to the earth; but the particles of which it is composed, also reflect the rays of light, and it appears that they possess the property of reflecting the blue rays, the most copiously: the light, therefore, which is reflected back into the atmosphere, from the surface of the earth, falls upon these particles of air, and the blue rays are returned by reflection: this reflection is performed in every possible direction; so that whenever we look at the atmosphere, some of these rays fall upon our eyes; hence we see the air of a blue colour. If the atmosphere did not reflect any rays, though the objects, on the surface of the earth, would be illuminated, the sky would appear perfectly black.

Caroline. Oh, how melancholy would that be; and how pernicious to the sight, to be constantly viewing bright objects against a black sky. But what is the reason that bodies often change their colour; as leaves, which wither in autumn, or a spot of ink, which produces an iron-mould on linen?

Mrs. B. It arises from some chemical change, which takes place in the arrangement of the component parts; by which they lose their tendency to reflect certain colours, and acquire the power of reflecting others. A withered leaf thus no longer reflects the blue rays; it appears, therefore, yellow, or has a slight tendency to reflect several rays, which produce a dingy brown colour.

An ink spot on linen, at first absorbs all the rays; but, from the action of soap, or of some other agent, it undergoes a chemical change, and the spot partially regains its tendency to reflect colours, but with a preference to reflect the yellow rays, and such is the colour of the iron-mould. [Pg 194]

Emily. Bodies, then, far from being of the colour which they appear to possess, are of that colour to which they have the greatest aversion, with which they will not incorporate, but reject, and drive from them.

Mrs. B. It certainly is so; though I scarcely dare venture to advance such an opinion, whilst Caroline is contemplating her beautiful rose.

Caroline. My poor rose! you are not satisfied with depriving it of colour, but even make it have an aversion to it; and I am unable to contradict you.

Emily. Since dark bodies, absorb more solar rays than light ones, the former should sooner be heated if exposed to the sun?

Mrs. B. And they are found, by experience, to be so. Have you never observed a black dress, to be warmer than a white one?

Emily. Yes, and a white one more dazzling: the black is heated by absorbing the rays, the white is dazzling, by reflecting them.

Caroline. And this was the reason that the brown paper was burnt in the focus of the lens, whilst the white paper exhibited the most luminous spot, but did not take fire.

Mrs. B. It was so. It is now full time to conclude our lesson. At our next meeting, I shall give you a description of the eye.

Questions

1. (Pg. 179) What is meant by the refraction of light?
2. (Pg. 179) What is believed to be the cause of refraction?
3. (Pg. 180) How is a ray refracted in passing obliquely from air into water?
4. (Pg. 180) How is this refraction explained in [fig. 1, plate 19](#)?
5. (Pg. 180) What is [fig. 2](#) intended to explain?
6. (Pg. 180) What is the rule respecting refraction, by different mediums?
7. (Pg. 181) What is meant by the perpendicular?
8. (Pg. 181) How does [fig. 3, plate 19](#), elucidate the law of refraction?
9. (Pg. 181) What will be the effect on the apparent situation of the flower?
10. (Pg. 181) What effect has refraction upon the apparent depth of a stream of water?
11. (Pg. 182) How does the atmosphere refract the rays of the sun, as represented, [fig. 4](#)?
12. (Pg. 182) Why have we the rays of the sun always refracted?
13. (Pg. 182) What length of time is required for light to travel from the sun, to the earth?
14. (Pg. 182) What effect has this upon his apparent place?
15. (Pg. 182) How is the length of the day affected by refraction?
16. (Pg. 183) How are rays refracted, which fall obliquely upon a flat pane of glass, ([fig. 5, plate 19](#))?
17. (Pg. 183) What is the reason that objects are distorted, when seen through common window glass?
18. (Pg. 184) What is meant by a lens?
19. (Pg. 184) What are the five kinds called, represented at [fig. 1, plate 20](#)?
20. (Pg. 184) What is meant by the axis of a lens?
21. (Pg. 184) How are parallel rays, refracted by the double convex lens, [fig. 6, plate 19](#)?
22. (Pg. 184) What is meant by the focus of a lens?
23. (Pg. 184) What is the focal distance of parallel rays, from a double convex lens?
24. (Pg. 184) How are the rays refracted by a concave lens, [fig. 7, plate 19](#)?
25. (Pg. 185) What is the effect of one plane side in a lens?
26. (Pg. 185) How is the focus of the plano-convex lens situated, [fig. 2, plate 20](#)?
27. (Pg. 185) How does a convex lens magnify objects, [fig. 6, plate 19](#)?
28. (Pg. 185) What is the article denominated which is represented at [fig. 3, plate 20](#)?
29. (Pg. 185) How will a ray be refracted, which enters on one side of the prism, in the

- direction A B?
30. (Pg. [185](#)) What effect is produced by this refraction, as represented in [fig. 4, plate 20](#)?
 31. (Pg. [186](#)) Of what are the rays of white light said to be composed?
 32. (Pg. [186](#)) What colours are produced?
 33. (Pg. [186](#)) By what property, in light, does refraction enable us to separate these different rays?
 34. (Pg. [187](#)) What experiment may be performed with a piece of card, so as to exemplify the compound nature of light?
 35. (Pg. [187](#)) How can the same be shown by a lens, [fig. 5, plate 20](#)?
 36. (Pg. [187](#)) Is it certain that there are seven primitive colours in the spectrum?
 37. (Pg. [188](#)) How is the rainbow produced, and what is necessary to its production?
 38. (Pg. [188](#)) How are the solar rays affected by a convex lens?
 39. (Pg. [188](#)) Why is such a lens, called a burning glass?
 40. (Pg. [188](#)) Why are bodies of a dark colour, more readily inflamed, than those which are white?
 41. (Pg. [189](#)) What is believed to be the reason, why some bodies absorb more rays than others?
 42. (Pg. [189](#)) What determines the colour of any particular body?
 43. (Pg. [189](#)) What exemplifications are given?
 44. (Pg. [189](#)) By what reasoning is it proved, that bodies do not retain their colours in the dark?
 45. (Pg. [190](#)) What proof of the truth of this theory of colours, may be afforded by the prism?
 46. (Pg. [191](#)) Why will green leaves, when exposed to the red ray, appear of a dingy brown?
 47. (Pg. [191](#)) Bodies, in general, when placed in a ray differing in colour from their own, appear of a mixed hue, what causes this?
 48. (Pg. [191](#)) Why will bodies of a pale, or light hue, most perfectly, assume the different colours of the spectrum?
 49. (Pg. [192](#)) Upon what property in a body, does the darkness of its colour depend?
 50. (Pg. [192](#)) Why do some bodies appear white, others black, and others of different colours?
 51. (Pg. [192](#)) From what cause do blue articles appear green, by candle-light?
 52. (Pg. [193](#)) What is believed to be the cause, of the red appearance of the sun, through a fog, or misty atmosphere?
 53. (Pg. [193](#)) From what is the blue colour of the sky, thought to arise?
 54. (Pg. [193](#)) What would be the colour of the sky, did not the atmosphere reflect light?
 55. (Pg. [193](#)) From what cause do some bodies change their colour, as leaves formerly green, become brown, and ink, yellow?
 56. (Pg. [194](#)) Why is a black dress, warmer in the sunshine, than a white one of the same texture?

CONVERSATION XVII. ON THE STRUCTURE OF THE EYE, AND OPTICAL INSTRUMENTS.

[Pg 195]

DESCRIPTION OF THE EYE. OF THE IMAGE ON THE RETINA. REFRACTION BY THE HUMOURS OF THE EYE. OF THE USE OF SPECTACLES. OF THE SINGLE MICROSCOPE. OF THE DOUBLE MICROSCOPE. OF THE SOLAR MICROSCOPE. MAGIC LANTHORN. REFRACTING TELESCOPE. REFLECTING TELESCOPE.

MRS. B.

The body of the eye, is of a spherical form: ([fig. 1, plate 21.](#)) it has two membranous coats, or coverings; the external one, *a a a*, is called the sclerotica, this is commonly known under the name of the white of the eye; it has a projection in that part of the eye which is exposed to view, *b b*, which is called the transparent cornea, because, when dried, it has nearly the consistence of very fine horn, and is sufficiently transparent for the light to obtain free passage through it.

The second membrane which lines the cornea, and envelops the eye, is called the choroid, *c c c*; this has an opening in front, just beneath the cornea, which forms the pupil, or sight of the eye, *d d*, through which the rays of light pass into the eye. The pupil is surrounded by a coloured border called the iris, *e e*, which, by its muscular motion, always preserves the pupil of a circular form, whether it is expanded in the dark, or contracted by a strong light. This you will understand better by examining [fig. 2.](#)

Emily. I did not know that the pupil was susceptible of varying its dimensions.

Mrs. B. The construction of the eye is so admirable, that it is capable of adapting itself, more or less, to the circumstances in which it is placed. In a faint light, the pupil dilates so as to receive an additional quantity of rays, and in a strong light, it contracts, in order to prevent the intensity of the light from injuring the optic nerve. Observe Emily's eyes, as she sits looking towards the windows: the pupils appear very small, and the iris, large. Now, Emily, turn from the light, and cover your eyes with your hand, so as entirely to exclude it, for a few moments.

[Pg 196]

Caroline. How very much the pupils of her eyes are now enlarged, and the iris diminished! This is, no doubt, the reason why the eyes suffer pain, when from darkness, they suddenly come into a strong light; for the pupil being dilated, a quantity of rays must rush in, before it has time to contract.

Emily. And when we go from a strong light, into obscurity, we at first imagine ourselves in total darkness; for a sufficient number of rays cannot gain admittance into the contracted pupil, to enable us to distinguish objects: but in a few minutes it dilates, and we clearly perceive objects which were before invisible.

Mrs. B. It is just so. The choroid *c c*, is embued with a black liquor, which serves to absorb all the rays that are irregularly reflected, and to convert the body of the eye, into a more perfect camera obscura. When the pupil is expanded to its utmost extent, it is capable of admitting ten times the quantity of light, that it does when most contracted. In cats, and animals which are said to see in the dark, the power of dilatation and contraction of the pupil, is still greater; it is computed that the pupils of their eyes may admit one hundred times more light at one time than at another.

Within these coverings of the eye-ball, are contained, three transparent substances, called humours. The first occupies the space immediately behind the cornea, and is called the aqueous humour, *f f*, from its liquidity and its resemblance to water. Beyond this, is situated the crystalline humour, *g g*, so called from its clearness and transparency: it has the form of a lens, and refracts the rays of light in a greater degree of perfection, than any that have been constructed by art: it is attached by two muscles, *m m*, to each side of the choroid. The back part of the eye, between the crystalline humour and the retina, is filled by the vitreous humour, *h h*, which derives its name from a resemblance it is supposed to bear, to glass, or vitrified substances.

PLATE XXII.

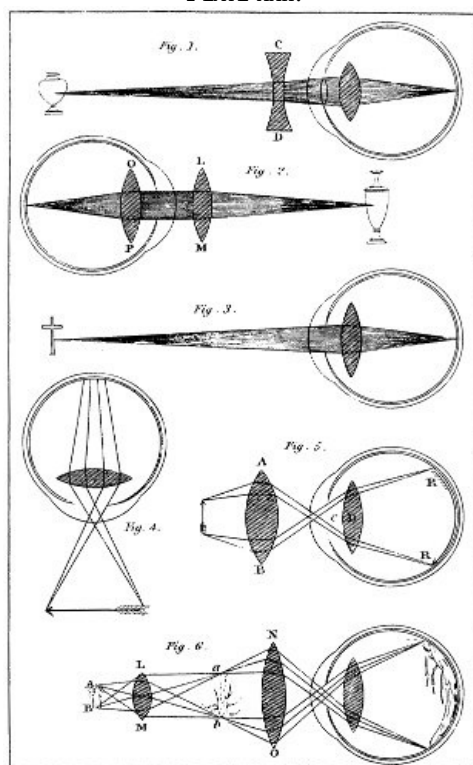

The membranous coverings of the eye are intended chiefly for the preservation of the retina, *i i*, which is by far the most important part of the eye, as it is that which receives the impression of the objects of sight, and conveys it to the mind. The retina is formed by the expansion of the optic nerve, and is of a most perfect whiteness: this nerve proceeds from the brain, enters the eye, at *n*, on the side next the nose, and is finely spread over the interior surface of the choroid.

[Pg 197]

The rays of light which enter the eye, by the pupil, are refracted by the several humours in their passage through them, and unite in a focus on the retina.

Caroline. I do not understand the use of these refracting humours: the image of objects was represented in the camera obscura, without any such assistance.

Mrs. B. That is true; but the representation became much more strong and distinct, when we enlarged the opening of the camera obscura, and received the rays into it, through a lens.

I have told you, that rays proceed from bodies in all possible directions. We must, therefore, consider every part of an object which sends rays to our eyes, as points from which the rays diverge, as from a centre.

Emily. These divergent rays, issuing from a single point, I believe you told us, were called a pencil of rays?

Mrs. B. Yes. Now, divergent rays, on entering the pupil, do not cross each other; the pupil,

however, is sufficiently large to admit a small pencil of them; and these, if not refracted to a focus, by the humours, would continue diverging after they had passed the pupil, would fall dispersed upon the retina, and thus the image of a single point, would be expanded over a large portion of the retina. The divergent rays from every other point of the object, would be spread over a similar extent of space, and would interfere and be confounded with the first; so that no distinct image could be formed, and the representation on the retina would be confused, both in figure and colour. [Fig. 3.](#) represents two pencils of rays, issuing from two points of the tree, A B, and entering the pupil C, refracted by the crystalline humour D, and forming on the retina, at *a b*, distinct images of the spot they proceed from. [Fig. 4.](#) differs from the preceding, merely from not being supplied with a lens; in consequence of which, the pencils of rays are not refracted to a focus, and no distinct image is formed on the retina. I have delineated only the rays issuing from two points of an object, and distinguished the two pencils in [fig. 4.](#) by describing one of them with dotted lines: the interference of these two pencils of rays on the retina, will enable you to form an idea of the confusion which would arise, from thousands and millions of points, at the same instant pouring their divergent rays upon the retina.

[Pg 198]

Emily. True; but I do not yet well understand, how the refracting humours, remedy this imperfection.

Mrs. B. The refraction of these several humours, unites the whole of a pencil of rays, proceeding from any one point of an object, to a corresponding point on the retina, and the image is thus rendered distinct and strong. If you conceive, in [fig. 3.](#), every point of the tree to send forth a pencil of rays, similar to those from A B, every part of the tree will be as accurately represented on the retina, as the points *a b*.

Emily. How admirably, how wonderfully, is this contrived!

Caroline. But since the eye absolutely requires refracting humours, in order to have a distinct representation formed on the retina, why is not the same refraction equally necessary, for the images formed in the camera obscura?

Mrs. B. It is; excepting the aperture through which we receive the rays into the camera obscura, is extremely small; so that but very few of the rays diverging from a point, gain admittance; but when we enlarged the aperture, and furnished it with a lens, you found the landscape more perfectly represented.

Caroline. I remember how obscure and confused the image was, when you enlarged the opening, without putting in the lens.

Mrs. B. Such, or very similar, would be the representation on the retina, unassisted by the refracting humours.

You will now be able to understand the nature of that imperfection of sight, which arises from the eyes being too prominent. In such cases, the crystalline humour, D, ([fig. 5.](#)) being extremely convex, refracts the rays too much, and collects a pencil, proceeding from the object A B, into a focus, F, before they reach the retina. From this focus, the rays proceed, diverging, and consequently form a very confused image on the retina, at *a b*. This is the defect in short-sighted people.

Emily. I understand it perfectly. But why is this defect remedied by bringing the object nearer to the eye, as we find to be the case with short-sighted people?

Mrs. B. The nearer you bring an object to your eye, the more divergent the rays fall upon the crystalline humour, and consequently they are not so soon converged to a focus: this focus, therefore, either falls upon the retina, or at least approaches nearer to it, and the object is proportionally distinct, as in [fig. 6.](#)

Emily. The nearer, then, you bring an object to a lens, the further the image recedes behind it.

Mrs. B. Certainly. But short-sighted persons have another resource, for objects which they can not bring near to their eyes; this is, to place a concave lens, C D, ([fig. 1, plate 22.](#)) before the eye, in order to increase the divergence of the rays. The effect of a concave lens, is, you know, exactly the reverse of a convex one: it renders parallel rays divergent, and those which are already divergent, still more so. By the assistance of such glasses, therefore, the rays from a distant object, fall on the pupil, as divergent as those from a less distant object; and, with short-sighted people, they throw the image of a distant object, back, as far as the retina.

[Pg 199]

Caroline. This is an excellent contrivance, indeed.

Mrs. B. And tell me, what remedy would you devise for such persons as have a contrary defect in their sight; that is to say, who are long-sighted, in whom the crystalline humour, being too flat, does not refract the rays sufficiently, so that they reach the retina before they are converged to a point?

Caroline. I suppose that a contrary remedy must be applied to this defect; that is to say, a convex lens, L M, [fig. 2.](#) to make up for the deficiency of convexity of the crystalline humour, O P. For the convex lens would bring the rays nearer together, so that they would fall, either less divergent, or parallel, on the crystalline humour; and, by being sooner converged to a focus, would fall on the retina.

Mrs. B. Very well, Caroline. This is the reason why elderly people, the humours of whose eyes are decayed by age, are under the necessity of using convex spectacles. And when deprived of that resource, they hold the object at a distance from their eyes, as in [fig. 3](#), in order to bring the focus more forward.

Caroline. I have often been surprised, when my grandfather reads without his spectacles, to see him hold the book at a considerable distance from his eyes. But I now understand the cause; the more distant the object is from the crystalline lens, the nearer to it, will the image be formed.

Emily. I comprehend the nature of these two opposite defects very well; but I cannot now conceive, how any sight can be perfect: for, if the crystalline humour is of a proper degree of convexity, to bring the image of distant objects to a focus on the retina, it will not represent near objects distinctly; and if, on the contrary, it is adapted to give a clear image of near objects, it will produce a very imperfect one, of distant objects.

Mrs. B. Your observation is very good, Emily; and it is true, that every person would be subject to one of these two defects, if we had it not in our power to adapt the eye, to the distance of the object; it is believed that this is accomplished, by our having a command over the crystalline lens, so as to project it towards, or draw it back from the object, as circumstances require, by means of the two muscles, to which the crystalline humour is attached; so that the focus of the rays, constantly falls on the retina, and an image is formed equally distinct, either of distant objects, or of those which are near.

[Pg 200]

Caroline. In the eyes of fishes, which are the only eyes I have ever seen separate from the head, the cornea does not protrude, in that part of the eye which is exposed to view.

Mrs. B. The cornea of the eye of a fish is not more convex than the rest of the ball of the eye; but to supply this deficiency, their crystalline humour is spherical, and refracts the rays so much, that it does not require the assistance of the cornea to bring them to a focus on the retina.

Emily. Pray, what is the reason that we cannot see an object distinctly, if we place it very near to the eye?

Mrs. B. Because the rays fall on the crystalline humour, too divergent to be refracted to a focus on the retina; the confusion, therefore, arising from viewing an object too near the eye, is similar to that which proceeds from a flattened crystalline humour; the rays reach the retina before they are collected to a focus, ([fig. 4](#).) If it were not for this imperfection, we should be able to see and distinguish the parts of objects, which, from their minuteness, are now invisible to us; for, could we place them very near the eye, the image on the retina would be so much magnified, as to render them visible.

Emily. And could there be no contrivance, to convey the rays of objects viewed, close to the eye, so that they should be refracted to a focus on the retina?

Mrs. B. The microscope is constructed for this purpose. The single microscope ([fig. 5](#).) consists simply of a convex lens, commonly called a magnifying glass; in the focus of which the object is placed, and through which it is viewed: by this means, you are enabled to place your eye very near to the object, for the lens A B, by diminishing the divergence of the rays, before they enter the pupil C, makes them fall parallel on the crystalline humour D, by which they are refracted to a focus on the retina, at R R.

Emily. This is a most admirable invention, and nothing can be more simple; for the lens magnifies the object, merely by allowing us to bring it nearer to the eye.

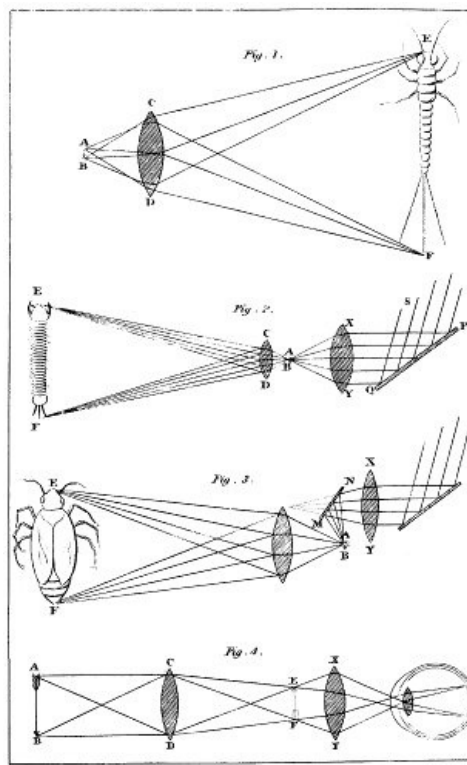

Mrs. B. Those lenses, therefore, which have the shortest focus will magnify the object most, because they enable us to place it nearest to the eye. [Pg 201]

Emily. But a lens, that has the shortest focus, is most bulging or convex; and the protuberance of the lens will prevent the eye from approaching very near to the object.

Mrs. B. This is remedied by making the lens extremely small: it may then be spherical without occupying much space, and thus unite the advantages of a short focus, and of allowing the eye to approach the object.

There is a mode of magnifying objects, without the use of a lens: if you look through a hole, not larger than a small pin, you may place a minute object near to the eye, and it will be distinct, and greatly enlarged. This piece of tin has been perforated for the purpose; place it close to your eye, and this small print before it.

Caroline. Astonishing! the letters appear ten times as large as they do without it: I cannot conceive how this effect is produced.

Mrs. B. The smallness of the hole, prevents the entrance into the eye, of those parts of every pencil of rays which diverge much; so that, notwithstanding the nearness of the object, those rays from it, which enter the eye, are nearly parallel, and are, therefore, brought to a focus by the humours of the eye.

Caroline. We have a microscope at home, which is a much more complicated instrument than that you have described.

Mrs. B. It is a double microscope, ([fig. 6.](#)) in which you see, not the object A B, but a magnified image of it, *a b*. In this microscope, two lenses are employed; the one, L M, for the purpose of magnifying the object, is called the object-glass, the other, N O, acts on the principle of the single microscope, and is called the eye-glass.

There is another kind of microscope, called the solar microscope, which is the most wonderful from its great magnifying power: in this we also view an image formed by a lens, not the object itself. As the sun shines, I can show you the effect of this microscope; but for this purpose, we must close the shutters, and admit only a small portion of light, through the hole in the window-shutter, which we used for the camera obscura. We shall now place the object A B, ([plate 23, fig. 1.](#)) which is a small insect, before the lens C D, and nearly at its focus: the image E F, will then be represented on the opposite wall, in the same manner, as the landscape was in the camera obscura; with this difference, that it will be magnified, instead of being diminished. I shall leave you to account for this, by examining the figure. [Pg 202]

Emily. I see it at once. The image E F is magnified, because it is farther from the lens, than the object A B; while the representation of the landscape was diminished, because it was nearer the lens, than the landscape was. A lens, then, answers the purpose equally well, either for magnifying or diminishing objects?

Mrs. B. Yes: if you wish to magnify the image, you place the object near the focus of the lens; if you wish to produce a diminished image, you place the object at a distance from the lens, in order that the image may be formed in, or near the focus.

Caroline. The magnifying power of this microscope is prodigious: but the indistinctness of the

image, for want of light, is a great imperfection. Would it not be clearer, if the opening in the shutter were enlarged, so as to admit more light?

Mrs. B. If the whole of the light admitted, does not fall upon the object, the effect will only be to make the room lighter, and the image consequently less distinct.

Emily. But could you not by means of another lens, bring a large pencil of rays to a focus on the object, and thus concentrate upon it the whole of the light admitted?

Mrs. B. Very well. We shall enlarge the opening, and place the lens X Y ([fig. 2.](#)) in it, to converge the rays to a focus on the object A B. There is but one thing more wanting to complete the solar microscope, which I shall leave to Caroline's sagacity to discover.

Caroline. Our microscope has a small mirror attached to it, upon a moveable joint, which can be so adjusted as to receive the sun's rays, and reflect them upon the object: if a similar mirror were placed to reflect light upon the lens, would it not be a means of illuminating the object more perfectly?

Mrs. B. You are quite right. P Q ([fig. 2.](#)) is a small mirror, placed on the outside of the window-shutter, which receives the incident rays S S, and reflects them on the lens X Y. Now that we have completed the apparatus, let us examine the mites on this piece of cheese, which I place near the focus of the lens.

Caroline. Oh, how much more distinct the image now is, and how wonderfully magnified! The mites on the cheese look like a drove of pigs scrambling over rocks.

Emily. I never saw any thing so curious. Now, an immense piece of cheese has fallen: one might imagine it an earthquake: some of the poor mites must have been crushed; how fast they run—they absolutely seem to gallop.

[Pg 203]

But this microscope can be used only for transparent objects; as the light must pass through them, to form the image on the wall?

Mrs. B. Very minute objects, such as are viewed in a microscope, are generally transparent, but when opaque objects are to be exhibited, a mirror M N ([fig. 3.](#)) is used to reflect the light on the side of the object next the wall: the image is then formed by light reflected from the object, instead of being transmitted through it.

Emily. Pray, is not a magic lantern constructed on the same principles?

Mrs. B. Yes, with this difference; the objects to be magnified, are painted upon pieces of glass, and the light is supplied by a lamp, instead of the sun.

The microscope is an excellent invention to enable us to see and distinguish objects, which are too small to be visible to the naked eye. But there are objects, which, though not really small, appear so to us, from their distance; to these, we cannot apply the same remedy; for when a house is so far distant, as to be seen under the same angle as a mite which is close to us, the effect produced on the retina is the same: the angle it subtends is not large enough for it to form a distinct image on the retina.

Emily. Since it is impossible, in this case, to make the object approach the eye, cannot we by means of a lens bring an image of it, nearer to us?

Mrs. B. Yes; but then the object being very distant from the focus of the lens, the image would be too small to be visible to the naked eye.

Emily. Then, why not look at the image through another lens, which will act as a microscope, enable us to bring the image close to the eye, and thus render it visible?

Mrs. B. Very well, Emily; I congratulate you on having invented a telescope. In [figure 4](#), the lens C D, forms an image E F, of the object A B; and the lens X Y, serves the purpose of magnifying that image; and this is all that is required in a common refracting telescope.

Emily. But in [fig. 4](#), the image is not inverted on the retina, as objects usually are: it should therefore appear to us inverted; and that is not the case in the telescopes I have looked through.

Mrs. B. When it is necessary to represent the image erect, two other lenses are required; by which means a second image is formed, the reverse of the first, and consequently upright. These additional glasses are used to view terrestrial objects; for no inconvenience arises from seeing the celestial bodies inverted.

[Pg 204]

Emily. The difference between a microscope and a telescope, seems to be this:—a microscope produces a magnified image, because the object is nearest the lens; and a telescope produces a diminished image, because the object is furthest from the lens.

Mrs. B. Your observation applies only to the lens C D, or object-glass, which serves to bring an image of the object nearer the eye; for the lens X Y, or eye-glass, is, in fact, a microscope, as its purpose is to magnify the image.

When a very great magnifying power is required, telescopes are constructed with concave mirrors, instead of lenses. These are called reflecting telescopes, because the image is reflected by metallic mirrors. Concave mirrors, you know, produce by reflection, an effect similar to that of

convex lenses, by refraction. In reflecting telescopes, therefore, mirrors are used in order to bring the image nearer the eye; and a lens, or eye-glass, the same as in the refracting telescope, to magnify the image.

The advantage of the reflecting telescope is, that mirrors whose focus is six feet, will magnify as much as lenses of a hundred feet: an instrument of this kind may, therefore, possess a high magnifying power, and yet be so short, as to be readily managed.

Caroline. But I thought it was the eye-glass only which magnified the image; and that the other lens, served to bring a diminished image nearer to the eye.

Mrs. B. The image is diminished in comparison with the object, it is true; but it is magnified, if you compare it to the dimensions of which it would appear without the intervention of any optical instrument; and this magnifying power is greater in reflecting, than in refracting telescopes.

We must now bring our observations to a conclusion, for I have communicated to you the whole of my very limited stock of knowledge of Natural Philosophy. If it enable you to make further progress in that science, my wishes will be satisfied; but remember, in order that the study of nature may be productive of happiness, it must lead to an entire confidence in the wisdom and goodness of its bounteous Author.

Questions

1. (Pg. 195) What is the form of the body of the eye? [fig. 1, plate 21.](#)
2. (Pg. 195) What is its external coat called?
3. (Pg. 195) What is the transparent part of this coat denominated?
4. (Pg. 195) What is the second coat named?
5. (Pg. 195) What opening is there in this?
6. (Pg. 195) What is the coloured part which surrounds the pupil?
7. (Pg. 195) The pupils dilate and contract, what purpose does this answer?
8. (Pg. 196) How could you observe the dilatation and contraction of the pupils?
9. (Pg. 196) What purpose is the choroid said to answer?
10. (Pg. 196) In what animals is the change in the iris greatest?
11. (Pg. 196) What are the three humours denominated, and how are they situated?
12. (Pg. 197) What is the part represented at *i i*, and of what does it consist?
13. (Pg. 197) What are the respective uses of the humours, and of the retina?
14. (Pg. 197) Why is it necessary the rays should be refracted?
15. (Pg. 197) How is this illustrated by [fig. 3 and 4, plate 21?](#)
16. (Pg. 198) What causes a person to be short-sighted? [fig. 5, plate 21.](#)
17. (Pg. 198) Why does placing an object near the eye, enable such, to see distinctly? [fig. 6.](#)
18. (Pg. 199) A concave lens remedies this defect; how? [fig. 1, plate 22.](#)
19. (Pg. 199) What is the remedy, when a person is long-sighted? [fig. 2.](#)
20. (Pg. 199) Why does holding an object far from the eye, help such persons? [fig. 3.](#)
21. (Pg. 200) How is the eye said to adapt itself to distant, and to near objects?
22. (Pg. 200) Why are objects rendered indistinct, when placed very near to the eye? [fig. 4, plate 22.](#)
23. (Pg. 200) What is the single microscope, [fig. 5,](#) and how does it magnify objects?
24. (Pg. 201) How may objects be magnified without the aid of a lens?
25. (Pg. 201) Why can an object, very near to the eye, be distinctly seen, when viewed through a small hole?
26. (Pg. 201) Describe the double microscope, as represented in [fig. 6, plate 22.](#)
27. (Pg. 202) How does the solar microscope, ([fig. 1 plate 23.](#)) operate?
28. (Pg. 202) Why may minute objects be greatly magnified by this instrument?
29. (Pg. 202) In its more perfect form it has other appendages, as seen in [fig. 2,](#) what are they? and what their uses?
30. (Pg. 203) What is added when opaque objects are to be viewed? [fig. 3.](#)
31. (Pg. 203) In what does the magic lantern differ from the solar microscope?
32. (Pg. 203) What are the use and structure of the telescope, as shown in [fig. 4?](#)
33. (Pg. 204) When terrestrial objects are to be viewed, why are two additional lenses employed?
34. (Pg. 204) What part of the telescope performs the part of a microscope?
35. (Pg. 204) In what does the reflecting, differ from the refracting telescope?
36. (Pg. 204) What advantages, do reflecting, possess over refracting telescopes?

GLOSSARY.

[Pg 205]

ACCELERATED MOTION. Motion is said to be accelerated, when the velocity is continually increasing.

ACCIDENTAL PROPERTIES. Those properties of bodies which are liable to change, as colour, form, &c.

ACUTE.—See [ANGLE.](#)

AIR. An elastic fluid. The atmosphere which surrounds the earth, is generally understood by this term, but there are many kinds of air. The term is synonymous with *Gas.*

AIR PUMP. An instrument by which vessels may be exhausted of air.

ALTITUDE. The height in degrees of the sun, or any heavenly body, above the horizon.

ANGLE. The space contained between two lines inclined to each other, and which meet in a point. Angles are measured in degrees, upon a segment of a circle described by placing one leg of a pair of compasses on the angular point, and with the other, describing the segment between the two lines. If the segment be exactly 1-4th of a circle, it is called a *right* angle, and contains 90 deg. If more than 1-4th of a circle, it is an *obtuse* angle. If less, an *acute* angle. See [plate 2](#).

ANGLE OF INCIDENCE, is the space contained between a ray which falls obliquely upon a body, and a line perpendicular to the surface of the body, at the point where the ray falls.

ANGLE OF REFLECTION. The space contained between a reflected ray, and a line perpendicular to the reflecting point.

ANGLE OF VISION, or visual angle. The space contained between lines drawn from the extreme parts of any object, and meeting in the eye.

ANTARCTIC CIRCLE. A circle extending round the south pole, at the distance of 23 1-2 degrees from it. The same as the south frigid zone.

APHELION. That part of the orbit of a planet, in which its distance from the sun is the greatest.

AREA. The surface enclosed between the lines which form the boundary of any figure, whether regular or irregular.

ARIES. See [SIGN](#).

ASTEROIDS. The name given to the four small planets, Ceres, Juno, Pallas, and Vesta.

ASTRONOMY. The science which treats of the motion and other phenomena of the sun, the planets, the stars, and the other heavenly bodies.

ATMOSPHERE. The air which surrounds the earth, extending to an unknown height. Wind is this air in motion.

ATTRACTION. A tendency in bodies to approach each other, and to exist in contact.

ATTRACTION OF COHESION. That attraction which causes matter to remain in masses, preventing them from falling into powder. For this attraction to exist, the particles must be contiguous.

ATTRACTION OF GRAVITATION. By this attraction, masses of matter, placed at a distance, have a tendency to approach each other. Attraction is mutual between the sun and the planets.

AXIS OF THE EARTH, OR OF ANY OF THE PLANETS. An imaginary line passing through their centres, and terminating at their poles; round this their diurnal revolutions are performed.

AXIS OF MOTION. The imaginary line, around which all the parts of a body revolve, when it has a spinning motion.

AXIS OF A LENS, OR MIRROR. A line passing through the centre of a lens, or mirror, in a direction perpendicular to its surface. [Pg 206]

BALLOON. Any hollow globe. The term is generally applied to those which are made to ascend in the air.

BAROMETER. Commonly called a weather-glass. It has a glass tube, containing quicksilver, which by rising and falling, indicates any change in the pressure of the atmosphere, and thus frequently warns us of changes in the weather.

BODY. The same as *Matter*. It may exist in the solid, liquid, or æriform state; and includes every thing with which we become acquainted by the aid of the senses.

BURNING-GLASS, OR MIRROR. A lens, or a mirror, by which the rays of light, and heat, are brought to a focus, so as to set bodies on fire.

CAMERA OBSCURA, a darkened room; or more frequently a box, admitting light by one opening, where a lens is placed; which, bringing the rays of light, from external objects, to a focus, presents a perfect picture of them, in miniature.

CAPILLARY TUBES. Tubes, the bore of which is very small. Glass tubes are usually employed, to show the phenomenon of *capillary attraction*. Fluids in which they are immersed, rise in such tubes above the level of that in the containing vessel.

CENTRE OF A CIRCLE. A point, equally distant from every part of its circumference.

CENTRE OF GRAVITY. That point within a body, to which all its particles tend, and around which they exactly balance each other. A system of bodies, as the planets, may have a common centre of gravity, around which they revolve in their orbits; whilst each, like the earth, has its particular centre of gravity within itself.

CENTRE OF MOTION. That point about which the parts of a revolving body move, which point is, itself, considered as in a state of rest.

CENTRE OF MAGNITUDE. The middle point of any body. Suppose a globe, one side of which is formed of lead, and the other of wood, the centres of magnitude and of gravity, would not be in the same points.

CENTRAL FORCES. Those which either impel a body towards, or from, a centre of motion.

CENTRIFUGAL. That which gives a tendency to fly from a centre.

CENTRIPETAL. That which impels a body, towards a centre.

CIRCLE. A figure; the periphery, or circumference of which, is every where equally distant, from the point, called its centre.

CIRCLE, GREAT. On the globe, or earth, is one that divides it into two equal parts, or hemispheres. The equator, and meridian lines, are great circles.

CIRCLE, LESSER. Those which divide the globe into unequal parts. The tropical, arctic and antarctic circles, and all parallels of latitude, are lesser circles.

CIRCUMFERENCE. The boundary line of any surface, as that which surrounds the centre of a circle; the four sides of a square, &c.

COMETS. Bodies which revolve round the sun, in very long ovals, approaching him very nearly in their perihelion, but in their aphelion, passing to a distance immeasurably great.

COHESION. See [ATTRACTION](#).

COMPRESSIBLE. Capable of being forced into a smaller space.

CONCAVE. Hollowed out; the inner surface of a watch-glass is concave, and may represent the form of a *concave mirror*, or *lens*.

CONVEX. Projecting, or bulging out, as the exterior surface of a watch-glass, which may represent the form of a *convex mirror*, or *lens*.

CONE. A body somewhat resembling a sugar-loaf; that is, having a round base, and sloping at the sides, until it terminates in a point.

CONJUNCTION. When three of the heavenly bodies are in a straight or right line, if you take either of the extreme bodies, the other two are in conjunction with it; because a straight line drawn from it, might pass through the centres of both, and join them together. At the time of new moon, the moon and sun are in conjunction with the earth; and the moon and earth, are in conjunction with the sun.

[Pg 207]

CONSTELLATION, OR SIGN. A collection of stars. Astronomers have imagined pictures drawn in the heavens, so as to embrace a number of contiguous stars, and have named the group after the animal, or other article supposed to be drawn; an individual star is generally designated by its fancied location; as upon the ear of *Leo*, the Lion, &c.

CONVERGENT RAYS, are those which approach each other, so as eventually to meet in the same point.

CRYSTALS. Bodies of a regular form, having flat surfaces, and well defined angles. Nitre, and other salts, are familiar examples. Many masses of matter, are composed of crystals too minute to be discerned without glasses.

CURVILINEAR, consisting of a line which is not straight, as a portion of a circle, of an oval, or any curved line.

CYLINDER. A body in the form of a roller, having flat circular ends, and being of equal diameter throughout.

DEGREE. If a circle of any size be divided into 360 equal parts, each of these parts is called a degree. One quarter of a circle contains ninety degrees; one twelfth of a circle, thirty degrees. The actual length of a degree, must depend upon the size of the circle. A degree upon the equator, upon a meridian, or any great circle of the earth, is equal to $69\frac{1}{2}$ miles.

Straight lines are sometimes divided into equal parts, called degrees; but these divisions are arbitrary, bearing no relationship to the degrees upon a circle.

DENSITY. Closeness of texture. When two bodies are equal in bulk, that which weighs the most, has the greatest density.

DIAGONAL. A line drawn so as to connect two remote angles of a square, or other four-sided figure.

DILATATION. The act of increasing in size. Bodies in general, dilate when heated, and contract by cooling.

DISCORD. When the vibrations of the air, produced by two musical tones, do not bear a certain ratio to each other, a jarring sound is produced, which is called discord.

DIVERGENT RAYS. Those which proceed from the same point, but are continually receding from each other.

DIVISIBILITY. Capability of being divided, or of having the parts separated from each other. This is called one of the *essential properties* of matter; because, however minute the particles may be, they must still contain as many halves, quarters, &c. as the largest mass of matter.

ECHO. A sound reflected back, by some substance, so situated as to produce this effect.

ECLIPSE. The interruption of the light of the sun, or of some other heavenly body, by the intervention of an opaque body. The moon passing between the earth and the sun, causes an eclipse of the latter.

ECLIPTIC. A circle in the heavens. The apparent path of the sun, through the twelve signs of the zodiac. This is caused by the actual revolution of the earth, round the sun. It is called the ecliptic, because eclipses always happen in the direction of that line, from the earth.

ELASTICITY. That property of bodies, by which they resume their dimensions and form, when the force which changed them is removed. Air is eminently elastic. Two ivory balls, struck together, become flattened at the point of contact; but immediately resuming their form, they react upon each other.

ELLIPSIS. An oval. This figure differs from a circle, in being unequal in its diameters, and in having two centres, or points, called its *foci*. The orbits of the planets are all elliptical.

EQUATOR. That imaginary line which divides the earth into northern and southern hemispheres, and which is equally distant from each pole. [Pg 208]

EQUILIBRIUM. When two articles exactly balance each other, they are in equilibrium. They may, notwithstanding, be very unequal in weight, but they must be so situated, that, if set in motion, their momentums would be equal.

EQUINOX. The two periods of time at which the nights and days are every where of equal length. The *vernal* equinox is in March, when the sun enters the sign *Aries*; the *autumnal* equinox in September, when the sun enters *Libra*. At these periods, the sun is vertical at the equator.

EXHALATIONS. All those articles which arise from the earth, and mixing with the atmosphere, form vapour.

EXPANSION. The same as [dilatation](#), which see.

EXTENSION. One of the essential properties of matter; that by which it occupies some space, to the exclusion of all other matter.

FIGURE. All matter must exist in some form, or shape; hence figure is deemed an essential property of matter.

FLUID. A form of matter, in which its particles readily flow, or slide, over each other. Airs, or gases, are called elastic fluids, because they are readily reduced to a smaller bulk by pressure. Liquids, are denominated non-elastic fluids, because they suffer but little diminution of bulk, by any mechanical force.

FOCUS. That point in which converging rays unite.

FORCE. That power which acts upon a body, either tending to create, or to stop motion.

FOUNTAIN. A jet, or stream of water, forced upwards by the weight of other water, by the elasticity of air, or some other mechanical pressure.

FRICTION. The rubbing of bodies together, by which their motion is retarded. Friction may be lessened, but cannot be destroyed.

FRIGID ZONES. The spaces or areas, contained within the arctic and antarctic circles.

FULCRUM. A prop. The point or axis, by which a body is supported, and about which it is susceptible of motion.

GAS. Any kind of air; of these there are several. The atmosphere consists of two kinds, mixed, or combined with each other.

GEOMETRY. That branch of the mathematics, which treats of lines, of surfaces, and of solids; and investigates their properties, and proportions.

GLOBE. A sphere, or ball. It has a point in its centre of magnitude, from which its surface is every where equally distant.

GRAVITY. That species of attraction which appears to be common to matter, existing in its particles, and giving to them, and of course to the masses which they compose, a tendency to approach each other. By gravity a stone falls to the earth, and by it the heavenly bodies tend towards each other.

HARMONY. A combination of musical sounds, produced by vibrations which bear a certain ratio to each other; and which thence affect the mind agreeably, when heard at the same time. Sounds not so related, produce discord.

HEMISPHERE. Half a sphere or globe. A plane passing through the centre of a globe, will divide it into hemispheres.

HORIZON. This is generally divided into *sensible*, and *rational*. The sensible horizon is that portion of the surface of the earth, to which our vision extends. Our rational horizon is that circle in the heavens which bounds our vision, when on the ocean, an extended plane, or any elevated situation. In the heavens our sensible, and our rational horizon are the same; its plane would

divide the earth into hemispheres at 90 degrees from us; and a person standing on that part of the earth which is directly opposite to us, would, at the same moment, see in his horizon, the same heavenly bodies, which would be seen in ours.

[Pg 209]

HORIZONTAL. Level; not inclined, or sloping. A perfectly round ball, placed upon a flat surface, which is placed horizontally, will remain at rest.

HYDRAULICS. That science which treats of water in motion, and the means of raising, conducting, and using it for moving machinery, or other purposes.

HYDROSTATICS. Treats of the weight, pressure, and equilibrium of fluids, when in a state of rest.

HYDROMETER. An instrument used to ascertain the specific gravity of different fluids, which it does, by the depth to which it sinks when floating on them.

IMAGE. The picture of any object which we perceive either by reflected or refracted light. All objects which are visible, become so by forming images on the retina.

IMPENETRABILITY. That property of matter, by which it excludes all other matter from occupying the same space with itself at the same time. If two particles could exist in the same space, so also might any greater number, and indeed all the matter in the universe, might be collected in a single point.

INCIDENCE. The direction in which a body, or a ray of light, moves in its approach towards any substance, upon which it strikes.

INCLINED PLANE. One of the six mechanical powers. Any plane surface inclined to the horizon, may be so denominated.

INERTIA. One of the inherent properties of matter. Want of power, or of any active principle within itself, by which it can change its own state, whether of motion, or of rest.

INHERENT PROPERTIES. Those properties which are absolutely necessary to the existence of a body; called also essential properties. All others are denominated accidental. Colour is an accidental—extension, an essential property of matter.

LATITUDE. Distance from the equator, in a direct line towards either pole. This distance is measured in degrees and minutes. The degree of latitude cannot exceed ninety, or one quarter of a circle. Places to the south of the equator, are in south latitude, and those to the north, in north latitude.

LATITUDE, PARALLELS OF. Lines drawn upon the globe, parallel to the equator, are so called; every place situated on such a line, has the same latitude, because equally distant from the equator.

LENS. A glass, ground so that one or both surfaces form segments of a sphere, serving either to magnify, or diminish objects seen through them. Glasses used in spectacles are lenses.

LEVER. One of the mechanical powers. An inflexible bar of wood or metal, supported by a fulcrum, or prop; and employed to increase the effect of a given power.

LIBRA. One of the twelve signs of the zodiac. That into which the sun enters, at the autumnal equinox.

LIGHT. That principle, by the aid of which we are able to discern all visible objects. It is generally believed to be a substance emitted by luminous bodies, and, exciting vision by passing into the eye.

LONGITUDE. Distance measured in degrees and minutes, either in an eastern, or a western direction, from any given point either on the equator, or on a parallel of latitude. Degrees of longitude may amount to 180, or half a circle. A degree of longitude measured upon the equator, is of the same length with a degree of latitude; but as the poles are approached, the degrees of longitude diminish in length, because the circles upon which they are measured, become less.

LUNAR. Relating to *Luna*, the moon.

LUNATION. The time in which the moon completes its circuit. A lunar month.

LUMINOUS BODIES. Those which emit light from their own substance; not shining by borrowed, or reflected light.

MACHINE. Any instrument, either simple or compound, by which any mechanical effect is produced. A needle, and a clock, are both machines.

[Pg 210]

MAGIC LANTHORN, OR LANTERN. An optical instrument, by which transparent pictures, painted upon glass, are magnified and exhibited on a white wall or screen, in a darkened room. The phantasmagoria, is a species of magic lanthorn.

MATHEMATICS. The science of numbers and of extension. Common arithmetic, is a lower branch of the mathematics. In its higher departments, it extends to every thing which is capable of being either numbered or measured.

MATTER. Substance. Every thing with which we become acquainted by the aid of the senses; every thing however large, or however minute, which has length, breadth, and thickness.

MECHANICS. That science which investigates the principles, upon which the action of every machine depends; and teaches their proper application in overcoming resistance, and in producing motion, in all the useful purposes to which they are applied.

MEDIUM. In optics, is any body which transmits light. Air, water, glass, and all other transparent bodies, are media. Medium also denotes that in which any body moves. Air is the medium which conveys sound, and which enables birds to fly.

MELODY. A succession of such single musical sounds, as form a simple air or tune.

MERCURY. That planet which is nearest to the sun. Quicksilver, a metal, which remains fluid at the common temperature of the atmosphere. It is capable of being rendered solid, by intense cold.

MERIDIAN. Midday. A meridian line, is one which extends directly from one pole of the earth to the other; crossing the equator at right angles. It is therefore half of a great circle. The hour of the day is the same at every place situated on the same meridian. Longitude is measured from any given meridian, to the opposite meridian. Places at the same distance in degrees, to the east or west of any meridian, have the same longitude.

MICROSCOPE. An optical instrument, by which minute objects, are magnified, so as to enable us to perceive and examine such as could not be seen by the naked eye.

MINERAL. Earths, stones, metals, salts, and in general all substances dug out of the earth, are denominated minerals.

MINUTE. In time, the sixtieth part of an hour. In length, the sixtieth part of a degree. A minute of time, is an unvarying period; but a minute in length varies in extent, with the degree of which it forms a part. The degrees and minutes are equal in number, upon a common ring, upon the equator of the earth, or, on any circle of the heavens.

MIRRORS. Polished surfaces of metal, or of glass coated with metal, for the purpose of reflecting the rays of light, and the images of objects. Common looking-glasses, are mirrors. Those used in reflecting telescopes, are made of metal.

MOBILITY. Capable of being moved from one place to another. This is accounted one of the essential properties of matter, because we cannot conceive of its existence without this capacity.

MOMENTUM. The force, or power, with which a body in motion acts upon any other body, or tends to preserve its own quantity of motion. The momentum of a body, is compounded of its quantity of matter, and its velocity. A body weighing one pound, moving with a velocity of two miles in a minute, will possess the same momentum with one weighing two pounds, moving with a velocity of one mile in a minute.

MOTION. A continued and successive change of place, either of a whole body, or of the particles of which a body is composed; the earth in revolving upon its axis only, would not change its place as a body, but all the particles of which it is composed, would revolve round a common axis of motion. In revolving in its orbit, its whole mass is constantly occupying a new portion of space.

[Pg 211]

NATURAL PHILOSOPHY. That science which enquires into the laws which govern all the natural bodies in the universe, in all their changes of place, or of state.

NEAP TIDES. Those tides which occur when the moon is in her quadratures, or half way between new, and full moon; at these periods the tides are the lowest.

NODES. Those points in the orbit of the moon, or of a planet, where it crosses the ecliptic or plane of the earth's orbit. When passing to the north of the ecliptic, it is called the ascending node; when to the south of it, the descending node.

OBLATE. See [SPHEROID](#).

OCTAGON. A figure with eight sides, and consequently with eight angles.

OPAQUE. Not transparent; refusing a passage to the rays of light.

OPTICS. That branch of science which treats of light, and vision. It is generally divided into two parts. *Catoptrics*, which treats of the reflection of light, and *Dioptrics*, which treats of its refraction.

ORBIT. The line in which a primary planet moves in its revolution round the sun; or a secondary planet, in its revolution round its primary. These orbits are all elliptical, or oval.

PARABOLA. A particular kind of curve; that which a body describes in rising and in falling, when thrown upwards, in any direction not perpendicular to the horizon.

PARALLELOGRAM. A figure with four sides, having those which are opposite, parallel to each other. A square, an oblong square, and the figure usually called a diamond, are Parallelograms.

PARALLEL LINES. All lines, whether straight or curved, which are every where at an equal distance from each other, are parallel lines.

PARALLEL OF LATITUDE. See [LATITUDE](#).

PERIHELION. That part of the orbit of a planet, in which it approaches the sun most nearly.

PENDULUM. A body suspended by a rod, or line, so that it may vibrate, or oscillate, backwards and forwards. Pendulums of the same length, perform their vibrations in the same time, whatever may be their weight, and whether the arc of vibration, be long or short.

PERCUSSION. The striking of bodies against each other. The force of this, depends upon the momentum of the striking body.

PERIOD. The time required for the revolution of one of the heavenly bodies in its orbit.

PERPENDICULAR. Making an angle of 90 degrees with the horizon. When two lines which meet, make an angle of 90 degrees, they are perpendicular to each other.

PHASES. The various appearances of the disc, or face of the moon, and of the planets; that portion of them which we see illuminated by the rays of the sun.

PHENOMENON. Any natural appearance is properly so called; the term, however, is usually applied to extraordinary appearances, as eclipses, transits, &c.

PISTON. That part of a pump, or other engine which is made to fit into a hollow cylinder, or barrel; and to move up and down in it, in order to raise water, or for any other purpose.

PLANE. A perfectly flat surface. The plane of the orbit of a planet, is an imaginary flat surface, extending to every part of the orbit.

PLANET. Those bodies which revolve round the sun, in orbits nearly circular. They are divided into *primary*, and *secondary*; these latter are also called satellites, or moons; they revolve round the primary planets, and accompany them in their courses round the sun.

PLUMB-LINE. A string, or cord, by which a weight is suspended; it is used for the purpose of finding a line perpendicular to the horizon; the weight being always attracted towards the centre of the earth.

[Pg 212]

PNEUMATICS. That branch of natural philosophy, which treats of the mechanical properties of the atmosphere, or of air in general.

POLES. The extremities of the axis of motion either of our earth, or of any other revolving sphere. The poles of the earth have never been visited; the regions by which they are surrounded, being obstructed by impassable barriers of ice.

POWER. That force which we apply to any mechanical instrument, to effect a given purpose, is denominated power, from whatever source it may be derived. We have the power of weights, of springs, of horses, of men, of steam, &c.

PRISM. The instrument usually so called, is employed in optics to decompose the solar ray: it consists of a piece of solid glass, several inches in length, and having three flat sides; the ends are equal in size, and are of course triangular.

PRECESSION OF THE EQUINOXES. Every equinox takes place a few seconds of a degree, before the earth arrives at that part of the ecliptic in which the preceding equinox occurred. This phenomenon is called the precession of the equinoxes. There is consequently a gradual change of the places of the signs of the zodiac: a fact, the discovery of which has thrown much light on ancient chronology.

PROJECTION. That force by which motion is given to a body, by some power acting upon it, independently of gravity.

PULLEY. One of the six mechanical powers. A wheel turning upon an axis, with a line passing over it. It is the moveable pulley only, which gives any mechanical advantage.

PUMP. An hydraulic, or pneumatic instrument, for the purpose of raising water, or exhausting air.

QUADRANT. A quarter of a circle. An instrument used to measure the elevation of a body in degrees above the horizon.

QUADRATURES OF THE MOON. That period in which she appears in the form of a semicircle. She is then either in her first, or her last quarter; and exactly half way, between the places of new, and of full moon.

RADIATION. The passage of light or heat in rays, or straight lines; these being projected from every luminous, or heated point, in all directions.

RADIUS. The distance from the centre of a circle, to its circumference; or one half of its diameter. In the plural denominated radii.

RAINBOW. An appearance in the atmosphere, occasioned by the decomposition of solar light, in its refraction, and reflection, in passing through drops of rain. The bow can be seen, only when the sun is near the horizon, when the back is turned towards it, and there is a shower in the opposite direction.

RAY. A single line of light, emitted in one direction, from any luminous point.

REACTION. Every body, whether in a state of motion, or at rest, tends to remain in such state, and resists the action of any other body upon it, with a force equal to that action. This resistance, is

called its *reaction*.

RECEIVER. This name is applied to glass vessels of various kinds, appertaining to the air pump, and from which the air may be exhausted. They are made to contain, or receive, any article upon which an effect is to be produced, by taking off the pressure of the atmosphere.

REFRACTION, of the rays of light, is the bending of those rays, when they pass obliquely from one medium into another of different density. A stick held obliquely in water, appears bent or broken at the surface of the fluid.

REFRANGIBILITY. Capacity of being refracted. Light is decomposed by the prism, because its component parts are refrangible in different degrees, by the same refracting medium.

[Pg 213]

REPULSION. The reverse of attraction. A tendency in particles, or in masses of matter, to recede from each other. The matter of heat within a body, appears to counteract the attraction of its particles, so as to prevent absolute contact.

RETINA. That part of the ball of the eye, upon which the images of visible objects are formed; and from which, the idea of such forms, is conveyed to the mind.

REVOLUTION, of a planet; is either diurnal, or annual; the former, is its turning upon its own axis; the latter, is its passage in its orbit.

SATELLITES. Moons, secondary planets.

SEGMENT OF A CIRCLE. A portion, or part of a circle; called also, an arc of a circle.

SEMI-DIAMETER. Half the diameter. The semi-diameter of the earth, is the distance from its surface, to its centre.

SIDERIAL. Belonging to the stars. A sidereal day, is the time required for a star to reappear on a given meridian. A sidereal year, the period in which the sun appears to have travelled round the ecliptic, so as to have arrived opposite to any particular star, from which his course was calculated.

SIGNS, or CONSTELLATIONS. Collections, or groups, of stars. Those of the zodiac are twelve, corresponding with the twelve months in the year. In the centre of these the ecliptic is situated. The sun appears to pass in succession through these signs; entering the first degree of Aries, which is accounted the first sign, about the 21st of March.

SKY. That vast expanse, or space, in which the heavenly bodies are situated. Its blue appearance is supposed to arise from the particles of which the atmosphere is composed, possessing the property of reflecting the blue rays, in greatest abundance.

SOLAR. Appertaining to, or governed by, the sun: as the solar system, the solar year, solar eclipses.

SOLID. Not fluid. Having its parts connected so as to form a mass. Solid bodies, are not absolutely so, all undoubtedly containing pores, or spaces void of matter.

SOLSTICES. The middle of summer and the middle of winter; those two points in the orbit of the earth, in which its poles point most directly towards the sun.

SONOROUS BODIES. Those bodies which are capable of being put into a state of vibration, so as to emit sounds.

SPECIFIC GRAVITY. The relative weight of bodies of different species, when the same bulk of each is taken. Water has been chosen as the standard for comparison. If we say that the specific gravity of a body is 6, we mean, that its weight is six times as great as that of a portion of water, exactly equal to it in bulk.

SPECTRUM. That appearance of differently coloured rays, which is produced by the refraction of the solar ray, by means of a prism, is called the prismatic spectrum; it exhibits most distinctly, and beautifully, all the colours seen in the rainbow.

SPHERE. A globe, or ball.

SPHEROID. Spherical; a body approaching nearly to a sphere in its figure. The earth, is denominated an *oblate spheroid*; it not being an exact sphere, but flattened at the poles, so as to cause the polar diameter to be upwards of thirty miles less than the equatorial. Oblate, is the reverse of oblong, and means shorter in one direction, than in another.

SPRING TIDES. Those tides which occur at the time of new, or of full moon. The tides then rise to a greater height than at any other period.

SQUARE. A figure having four sides of equal length, and its angles all right angles.

In numbers; the product of a number multiplied into itself; thus, the square of 3 is 9, and the square of 8 is 64.

[Pg 214]

STAR. The *fixed* stars are so called, because they retain their relative situations; while the planets, by revolving in their orbits, appear to wander amongst the fixed stars.

SUBTEND. This term is applied to the measurement of an angle; when the lines by which it is

bounded recede but little from each other, they are said to subtend; that is, to be contained under, a small angle.

SUPERFICIES. The surface of any figure. Space extended in length and width.

SYSTEM. The mutual connexion, and dependance of things, upon each other. The solar, or Copernican system, includes the sun, the planets, with their moons, and the comets.

TANGENT. A straight line touching the circumference of a circle; but which would not cut off any portion of it, were it extended beyond the touching point, in both directions.

TELESCOPE. An instrument by which distant objects may be distinctly seen; the images of objects being brought near to the eye, and greatly magnified.

TEMPERATE ZONES. Those portions of the surface of the earth situated between $23\frac{1}{2}$ and $66\frac{1}{2}$ degrees of latitude. Within these boundaries, the sun is never vertical; nor does he ever remain, during a whole day, below the horizon.

THERMOMETER. An instrument for measuring the temperature of the atmosphere, or of other bodies.

TORRID ZONE. That portion of the earth which extends $23\frac{1}{2}$ degrees on each side of the equator, to the tropical circles; within this limit, the sun is vertical, twice in the year.

TRANSIT. Mercury or Venus, are said to transit the sun, when they pass between the earth and that luminary. They then appear like dark spots, upon the face of the sun.

TRANSPARENT. Allowing the rays of light to pass freely through. The reverse of opaque. Glass, water, air, &c. are transparent bodies.

TROPICS. Two circles on the globe on either hemisphere, at the distance of $23\frac{1}{2}$ degrees from the equator. Beyond these circles, the sun is never vertical: and the countries within them, are denominated tropical.

TWILIGHT. That portion of the morning or evening, in which the light of the sun is perceptible, although he is below the horizon.

VACUUM. Space void of matter. Such is supposed to be the space in which the planets revolve. We are said to produce a vacuum, when we exhaust the air from a receiver.

VALVE. A part of a pump, and of some other instruments, which opens to admit the passage of a fluid in one direction, but closes when pressed in the opposite direction, so as to prevent the return of the fluid; a pair of bellows is furnished with a valve.

VAPOUR. Exhalations from fluid or solid substances, generally mixing with the atmosphere. The most abundant, is that from water.

VERTICAL. Exactly over our heads: ninety degrees above our horizon.

VIBRATION. The alternate motion of a body, forwards and backwards; swinging, as a pendulum.

VISUAL. Belonging to vision; as the visual angle, or that angle formed by the rays of light which enter the eye, from the extremities of any object.

UNDULATION. A vibratory, or wave-like motion communicated to fluids. Sound, is said to be propagated by the undulatory, or vibratory motion of the air.

WEDGE. One of the mechanical powers; the form of the wedge is well known. It is of extensive use; serving to rend bodies of great strength, and to raise enormous weights.

WHEEL AND AXLE. One of the mechanical powers, used under various modifications. Cranes for raising weights, the wheels and pinions of clocks and watches, windlasses, &c. are all applications of this power.

[Pg 215]

ZODIAC. A broad belt in the heavens, extending nearly eight degrees on each side of the ecliptic; the planes of the orbits of all the planets are included within this space. This belt is divided into twelve parts or signs, each containing 30 degrees.

These signs are:

Aries; the Ram.

Taurus; the Bull.

Gemini; the Twins.

Cancer; the Crab.

Leo; the Lion.

Virgo; the Virgin.

Libra; the Scales.

Scorpio; the Scorpion.

Sagittarius; the Archer.

Capricornus; the Goat.

Aquarius; the Waterer.

Pisces; the Fishes.

The first six are called northern signs; because the sun is in them, during that half of the year, in

which he is vertical to the north of the equator; the last six, are called southern signs; because, during his journey among them, he is vertical to the south of the equator.

The sun enters *Aries*, at the time of the *vernal equinox*; *Cancer*, at the *summer solstice*; *Libra*, at the *autumnal equinox*; and *Capricornus*, at the *winter solstice*.

The sun is said to enter a sign, when the earth in going round in its orbit, enters the opposite sign. Thus, when the sun appears in the first degree of *Libra*, it is in consequence of the earth having arrived opposite to the first degree of *Aries*. A line then drawn from the earth, and passing through the centre of the sun, would, if extended to the fixed stars, touch the first degree of *Libra*.

ZONE. The earth is divided into zones, or belts. See [FRIGID](#), [TEMPERATE](#), and [TORRID ZONES](#).

INDEX.

[Pg 217]

A.

Air, [11](#), [15](#), [28](#), [50](#), [136](#).
Air-pump, [31](#), [145](#).
Angle, [44](#).
 acute, [44](#).
 obtuse, [44](#).
 right, [44](#).
 of incidence, [45](#), [154](#), [160](#), [173](#).
 of reflection, [45](#), [154](#), [160](#), [173](#).
 visual, [168](#), [169](#), [170](#).
Angular velocity, [171](#).
Antarctic circle, [92](#).
Aphelion, [75](#).
Arctic circle, [92](#).
Atmosphere, [28](#), [104](#), [129](#), [136](#), [144](#), [150](#), [163](#).
 colour of, [193](#).
 reflection of, [193](#).
 refraction of, [182](#).
Attraction, [10](#), [14](#), [23](#), [25](#), [179](#).
 of cohesion, [15](#), [19](#), [118](#).
 capillary, [18](#).
 of gravitation, [18](#), [23](#), [29](#), [70](#), [80](#), [96](#), [116](#), [136](#).
Avenue, [170](#).
Auditory nerve, [151](#).
Axis, [78](#).
 of motion, [48](#).
 of the earth, [22](#), [99](#).
 of mirrors, [176](#).
 of a lens, [184](#).

B.

Balloon, [30](#).
Barometer, [140](#).
Bass, [155](#).
Bladder, [138](#).
Bodies, [10](#).
 elastic, [40](#).
 fall of, [23](#), [26](#), [30](#), [36](#).
 luminous, [157](#).
 opaque, [157](#).
 sonorous, [152](#), [155](#).
 transparent, [157](#).
Bulk, [16](#).

C.

Camera obscura, [184](#), [197](#), [201](#).
Capillary tubes, [18](#).
Centre, [48](#).
 of gravity, [48](#), [51](#), [52](#), [115](#).
 of magnitude, [48](#), [53](#).
 of motion, [48](#), [55](#), [115](#).
Centrifugal force, [49](#), [72](#), [95](#), [115](#).
Centripetal force, [49](#), [72](#).
Ceres, [84](#).

Circle, [44](#), [94](#).
Circumference, [94](#).
Clouds, [129](#).
Colours, [23](#), [185](#).
Comets, [86](#).
Compression, [42](#).
Concord, [155](#).
Constellation, [86](#).
Convergent rays, [175](#), [177](#).
Crystals, [12](#).
Curvilinear motion, [47](#), [72](#).
Cylinder, [52](#).

D.

Day, [78](#), [105](#), [106](#).
Degrees, [44](#), [94](#), [99](#), [169](#), [170](#).
 of latitude, [94](#), [112](#).
 of longitude, [94](#), [112](#).
Density, [16](#).
Diagonal, [47](#).
Diameter, [94](#).
Discords, [155](#).
Diurnal, [78](#).
Divergent rays, [175](#), [177](#).
Divisibility, [10](#), [12](#).

E.

Earth, [18](#), [70](#), [84](#), [88](#), [95](#).
Echo, [154](#).
Eclipse, [110](#), [159](#).
Ecliptic, [86](#), [92](#), [99](#).
Elasticity, [41](#).
Elastic bodies, [28](#), [40](#).
 fluids, [28](#), [41](#), [118](#), [136](#).
Ellipsis, [75](#).
Equinox, [100](#), [107](#).
 precession of, [107](#).
Equator, [92](#), [99](#).
Essential properties, [10](#).
Exhalations, [13](#).
Extension, [10](#), [11](#).
Eye, [166](#), [195](#).

[Pg 218]

F.

Fall of bodies, [24](#), [27](#), [31](#).
Figure, [10](#), [12](#).
Fluids, [118](#), [128](#).
 elastic, [28](#), [41](#), [118](#), [136](#).
 equilibrium of, [120](#), [122](#), [132](#).
 non-elastic, [119](#).
 pressure of, [121](#).
Flying, [40](#).
Focus, [176](#).
 of concave mirrors, [177](#).
 of convex mirrors, [175](#), [177](#).
 of a lens, [184](#).
 imaginary, [176](#).
 virtual, [176](#).
Force, [33](#).
 centrifugal, [49](#), [72](#), [95](#), [115](#).
 centripetal, [49](#), [72](#).
 projectile, [47](#), [49](#).
 of gravity, [47](#), [49](#).
Fountains, [135](#).
Friction, [68](#), [69](#), [135](#).
Frigid zone, [93](#).
Fulcrum, [54](#).

G.

General properties of bodies, [10](#).
Georgium Sidus, [85](#).
Glass, [183](#).

burning, [188](#).
refraction of, [183](#).
Gold, [119](#), [126](#).
Gravity, [18](#), [23](#), [78](#), [97](#).

H.

Harmony, [155](#).
Heat, [16](#), [29](#), [103](#).
Hemisphere, [92](#), [100](#).
Herschel, [85](#).
Hydraulics, [118](#).
Hydrometer, [128](#).
Hydrostatics, [118](#).

I.

Image on the retina, [165](#), [172](#).
 reversed, [167](#).
 in plain mirror, [172](#).
 in concave do. [175](#).
 in convex do. [175](#).
Impenetrability, [10](#).
Inclined plane, [54](#), [66](#).
Inertia, [10](#), [14](#), [32](#).
Inherent properties, [10](#).
Juno, [84](#).
Jupiter, [85](#).

L.

Lake, [133](#), [135](#).
Latitude, [94](#), [112](#).
Lens, [184](#).
 concave, [184](#).
 convex, [184](#).
 meniscus, [184](#).
 plano-concave, [184](#).
 plano-convex, [184](#).
Lever, [54](#), [55](#).
 first kind, [58](#).
 second kind, [60](#).
 third kind, [60](#).
Light, [157](#).
 pencil of, [158](#).
 of the moon, [162](#), [163](#).
 absorption of, [188](#).
 reflected, [160](#).
 refraction of, [179](#).
Liquids, [118](#).
Longitude, [94](#), [112](#).
Luminous bodies, [157](#).
Lunar month, [108](#).
 eclipse, [110](#).

M.

Machine, [54](#), [66](#).
Magic lanthorn, [203](#).
Mars, [84](#).
Matter, [10](#), [13](#).
Mechanics, [32](#).
Mediums, [157](#), [180](#).
Melody, [156](#).
Mercury, (planet) [83](#), [85](#), [114](#).
Mercury, or quicksilver, [16](#), [140](#), [141](#).
Meridians, [93](#).
Microscope, [200](#).
 single, [200](#).
 double, [200](#).
 solar, [202](#), [203](#).
Minerals, [12](#).
Minutes, [94](#).
Momentum, [38](#), [56](#).
Monsoons, [149](#).
Month, lunar, [108](#).

Moon, [78](#), [79](#), [80](#), [82](#), [85](#).

Moonlight, [162](#), [163](#).

Motion, [14](#), [32](#), [36](#).

accelerated, [36](#).

axis of, [48](#).

centre of, [48](#), [55](#).

compound, [46](#).

curvilinear, [47](#), [49](#).

diurnal, [78](#).

perpetual, [35](#).

retarded, [35](#).

reflected, [43](#).

uniform, [34](#).

Mirrors, [172](#).

axis of, [176](#).

burning, [177](#).

concave, [174](#), [176](#), [209](#).

convex, [174](#), [175](#).

plane or flat, [172](#).

reflection of, [173](#).

N.

Neap tides, [116](#).

Nerves, [166](#).

auditory, [151](#), [166](#).

olfactory, [166](#).

optic, [164](#), [166](#).

Night, [78](#).

Nodes, [110](#).

O.

Octave, [156](#).

Odour, [13](#).

Opaque bodies, [157](#), [158](#).

Optics, [157](#).

Orbit, [86](#).

P.

Pallas, [84](#).

Parabola, [51](#).

Parallel lines, [25](#).

Parallel of latitude, [94](#).

Pellucid bodies, [157](#).

Pencil of rays, [158](#).

Pendulum, [98](#).

Perihelion, [75](#).

Perpendicular lines, [25](#).

Phases, [109](#).

Piston, [143](#), [145](#).

Plane, [92](#), [93](#).

Planets, [76](#), [81](#), [83](#).

Poles, [92](#), [99](#), [100](#).

Polar star, [100](#), [112](#).

Porosity, [42](#), [126](#).

Powers, mechanical, [54](#).

Projection, [49](#), [50](#), [71](#).

Precession of equinoxes, [107](#).

Pulley, [54](#), [63](#).

Pump, [31](#).

sucking and lifting, [143](#).

forcing, [144](#), [145](#).

air, [31](#), [145](#).

Pupil of the eye, [164](#).

R.

Rain, [17](#), [129](#).

Rainbow, [188](#).

Rarity, [16](#).

Ray of light, [158](#), [179](#).

reflected, [160](#), [161](#).

incident, [161](#).

Rays, intersecting, [165](#).

Reaction, [39](#).
Receiver, [31](#).
Reflection of light, [160](#), [163](#).
 angle of, [45](#), [161](#), [173](#).
 of mirrors, [173](#).
 of plane mirrors, [174](#).
 of concave do. [174](#).
 of convex do. [174](#).
Reflected motion, [43](#).
Refraction, [179](#), [186](#).
 of the atmosphere, [182](#).
 of glass, [183](#).
 of a lens, [184](#).
 of a prism, [185](#).
Resistance, [54](#).
Retina, [165](#).
 image on, [166](#).
Rivers, [134](#).
Rivulets, [131](#).

S.

Satellites, [80](#), [111](#), [113](#).
Saturn, [85](#).
Scales, or balance, [55](#).
Screw, [54](#), [67](#).
Shadow, [110](#), [111](#).
Siderial time, [106](#).
Sight, [165](#).
Signs of the zodiac, [86](#), [93](#).
Smoke, [14](#), [29](#).
Solar microscope, [202](#).
Solstice, [100](#), [102](#).
Sound, [151](#).
 acute, [155](#).
 musical, [155](#).
Space, [33](#).
Specific gravity, [123](#).
 of air, [140](#).
Spectrum, [190](#).
Speaking-trumpet, [154](#).
Sphere, [26](#).
Springs, [130](#).
Spring tides, [116](#).
Square, [81](#), [85](#).
Stars, [77](#), [86](#), [102](#).
Storms, [147](#).
Substance, [10](#).
Summer, [76](#), [100](#).
Sun, [71](#), [75](#), [78](#), [162](#), [182](#).
Swimming, [41](#).
Syphon, [132](#).

T.

Tangent, [49](#), [73](#).
Telescope, [203](#), [204](#).
 reflecting, [204](#).
 refracting, [204](#).
Temperate zone, [92](#), [101](#).
Thermometer, [142](#).
Tides, [114](#), [116](#).
 neap, [116](#).
 spring, [116](#).
 ærial, [150](#).
Time, [105](#), [107](#).
 siderial, [107](#).
 equal, [107](#).
 solar, [107](#).
Tone, [155](#).
Torrid zone, [93](#), [147](#), [182](#).
Transit, [114](#).
Transparent bodies, [157](#).
Treble and bass, [155](#).
Tropics, [92](#).

V.

Valve, [143](#).
Vapour, [17](#), [29](#), [104](#), [129](#).
Velocity, [33](#), [57](#).
Venus, [84](#).
Vesta, [84](#).
Vibration, [98](#), [152](#).
Vision, [164](#), [168](#).
Vision, angle of, [168](#), [170](#).
 double, [171](#).

U.

Undulation, [153](#).
Unison, [155](#).

W.

Water, [118](#), [130](#).
 spring, [130](#).
 rain, [130](#).
 level of, [120](#).
Wedge, [54](#), [66](#).
Weight, [23](#).
Wheel and axle, [54](#), [65](#).
Wind, [146](#).
 trade, [147](#).
 periodical, [148](#).
Winter, [76](#), [101](#).

Y.

Year, [107](#).
 siderial, [107](#).
 solar, [107](#).

Z.

Zodiac, [86](#).
Zone, [93](#).
 torrid, [93](#), [147](#), [182](#).
 temperate, [93](#), [101](#).
 frigid, [93](#), [100](#).

THE END.

TO ALL TEACHERS.

SCHOOL BOOKS.

**SMILEY'S GEOGRAPHY AND ATLAS, and SACRED AND ANCIENT
GEOGRAPHY FOR SCHOOLS.**

The above works will be found useful and very valuable as works of reference, as well as for schools. The Maps, composing the Atlases, will be found equal in execution and correctness to those on the most extensive scale. The author has received numerous recommendations, among which are the following:

Dear Sir—I have looked over your "*Easy Introduction to the Study of Geography*," together with your "*Improved Atlas*." I have no hesitation in declaring, that I consider them works of peculiar merit. They do honour to your industry, research, and talent, and I am satisfied, will facilitate the improvement of the student in geographical science.

With sentiments of sincere consideration, I am yours truly,

WM. STAUGHTON, D. D.
*President of Columbia College, District of
Columbia.*

MR. THOMAS SMILEY.
Philadelphia, Sept. 1, 1823.

Extract from the Minutes of the Philadelphia Academy of Teachers.

November 1, 1823.

Resolved unanimously, That the Academy of Teachers highly approve the superior merits of Mr. Smiley's "*Easy Introduction to the Study of Geography*," and the accompanying Atlas, and cordially recommend them to the patronage of the public.

B. MAYO, *President.*

I. I. HITCHCOCK, *Secretary.*

THE NEW FEDERAL CALCULATOR, or SCHOLAR'S ASSISTANT.

Containing the most concise and accurate Rules for performing the operations in common Arithmetic; together with numerous Examples under each of the Rules, varied so as to make them conformable to almost every kind of business. For the Use of Schools and Counting Houses.

By Thomas T. Smiley, Teacher: author of An Easy Introduction to the Study of Geography. Also, of Sacred Geography for the Use of Schools.

Among the numerous recommendations received to the work, are the following:

Phila. March 8, 1825.

MR. JOHN GRIGG.

SIR—I have examined with as much care as my time would admit, "The New Federal Calculator," by Thomas T. Smiley. It appears to me to be a treatise on Arithmetic of considerable merit. There are parts in Mr. Smiley's work which are very valuable; the rules given by him in Barter, Loss and Gain, and Exchange, are a great desideratum in a new system or treatise on Arithmetic, and renders his book superior to any on the subject now in use; and when it is considered that the calculations in the work are made in Federal Money, the only currency now known in the United States, and that appropriate questions follow the different rules, by which the learner can be exercised as to his understanding of each part as he progresses; I hesitate not to say, that, in my opinion, it is eminently calculated to promote instruction in the science on which it treats. Mr. Smiley deserves the thanks of the public and the encouragement of teachers, for his attempt to simplify and improve the method of teaching Arithmetic. I am yours respectfully,

WM. P. SMITH,
*Preceptor of Mathematics and Natural
Philosophy,
No. 152, South Tenth Street.*

SIR—I have carefully examined "The New Federal Calculator, or Scholar's Assistant," by Thomas T. Smiley, on which you politely requested my opinion; and freely acknowledge that I think it better calculated for the use of the United States schools and counting-houses than any book on the subject that I have seen. The author's arrangement of the four primary rules is, in my opinion, a judicious and laudable innovation, claiming the merit of improvement; as it brings together the rules nearest related in their nature and uses. His questions upon the rules throughout, appear to me to be admirably calculated to elicit the exertions of the learner. But above all, the preference he has given to the currency of his own country, in its numerous examples, has stamped a value upon this little work, which I believe has not fallen to the lot of any other book of the kind, as yet offered to the American public.

I am, sir, yours respectfully,
JOHN MACKAY.

Charleston, (S. C.) March 29, 1825.

From the United States Gazette.

Among the numerous publications of the present day, devoted to the improvement of youth, we have noticed a new edition of Smiley's Arithmetic, just published by J. Grigg.

The general arrangement of this book is an improvement upon the Arithmetics in

present use, being more systematic, and according to the affinities of different rules. The chief advantage of the present over the first edition, is a correction of several typographical errors, a circumstance which will render it peculiarly acceptable to teachers. In referring to the merits of this little work, it is proper to mention that a greater portion of its pages are devoted to Federal calculation, than is generally allowed in primary works in this branch of study. The heavy tax of time and patience which our youth are now compelled to pay to the errors of their ancestors, by performing the various operations of pounds, shillings, and pence, should be remitted, and we are glad to notice that the Federal computation is becoming the prominent practice of school arithmetic.

In recommending Mr. Smiley's book to the notice of parents and teachers, we believe that we invite their attention to a work that will really prove an "assistant" to them, and a "*guide*" to their interesting charge.

The Editors of the New York Telegraph, speaking of Smiley's Arithmetic, observe that they have within a few days attentively examined the above Arithmetic, and say, "We do not hesitate to pronounce it an improvement upon every work of the kind previously before the public; and as such, recommend its adoption in all our Schools and Academies."

A KEY to the above Arithmetic,

in which all the Examples necessary for a Learner are wrought at large, and also Solutions given of all the various Rules. Designed principally to facilitate the labour of Teachers, and assist such as have not the opportunity of a tutor's aid. By T. T. Smiley, author of the New Federal Calculator, &c. &c.

TORREY'S SPELLING BOOK, or First Book for Children.

I have examined Mr. Jesse Torrey's "Familiar Spelling Book." I think it a great improvement in the primitive, and not least important branches of education, and shall introduce it into the seminaries under my care, as one superior to any which has yet appeared.

IRA HILL, A. M.

Boonsborough, Feb. 2, 1825.

The increasing demand for this work is the best evidence of its merits.

A PLEASING COMPANION FOR LITTLE GIRLS AND BOYS,

blending Instruction with Amusement; being a Selection of Interesting Stories, Dialogues, Fables, and Poetry. Designed for the use of Primary Schools and Domestic Nurseries. By Jesse Torrey, Jr.

To secure the perpetuation of our republican form of government to future generations, let Divines and Philosophers, Statesmen and Patriots, unite their endeavours to renovate the age, by impressing the minds of the people with the importance of educating their *little boys and girls*.

S. ADAMS.

Report of the Committee of the Philadelphia Academy of Teachers: adopted Nov. 6, 1824.

The Committee, to whom was referred Mr. Jesse Torrey's "Pleasing Companion for Little Girls and Boys," beg leave to report,

That they have perused the "Pleasing Companion," and have much pleasure in pronouncing as their opinion, that it is a compilation much better calculated for the exercise and improvement of small children in the art of reading, and especially in the more rare art of understanding what they read, than the books in general use.

All which is respectfully submitted.

I. IRVINE HITCHCOCK,
PARDON DAVIS,
CHARLES MEAD,

A true copy from the minutes of the Academy.

C. B. TREGO, *Secretary.*

Nov. 22, 1824.

THE MORAL INSTRUCTOR AND GUIDE TO VIRTUE, by Jesse Torrey, Jr.

Among the numerous recommendations to this valuable School Book, are the following:—

Extract of a note from the Hon. Thomas Jefferson, late President of the United States.

"I thank you, sir, for the copy of your '*Moral Instructor.*' I have read the first edition with great satisfaction, and encouraged its reading in my family."

Extracts of a Letter from the Hon. James Madison, late President of the United States.

"Sir—I have received your letter of the 15th, with a copy of the *Moral Instructor.*

"I have looked enough into your little volume to be satisfied, that both the original and selected parts contain information and instruction which may be useful, not only to juvenile but most other readers.

"With friendly respects,
JAMES MADISON."

DR. TORREY.

From Roberts Vaux, President of the Controllers of the Public Schools in Philadelphia.

"The *Moral Instructor*" is a valuable compilation. It appears to be well adapted for elementary schools, and it will give me pleasure to learn that the lessons which it contains are furnished for the improvement of our youth generally.

Respectfully,
ROBERTS VAUX.

Philadelphia, 5th month, 8 1823.

HISTORY OF ENGLAND,

from the First Invasion by Julius Cæsar, to the Accession of George the Fourth, in eighteen hundred and twenty: comprising every Political Event worthy of remembrance; a Progressive View of Religion, Language, and Manners; of Men eminent for their Virtue or their Learning; their Patriotism, Eloquence, or Philosophical Research; of the Introduction of Manufactures, and of Colonial Establishments. With an interrogative Index, for the use of Schools. By William Grimshaw, author of a History of the United States, &c.

HISTORY OF THE UNITED STATES,

from their first settlement as Colonies, to the cession of Florida, in 1821: comprising every Important Political Event; with a Progressive View of the Aborigines; Population, Religion, Agriculture, and Commerce; of the Arts, Sciences, and Literature; occasional Biographies of the most remarkable Colonists, Writers, and Philosophers, Warriors, and Statesmen; and a Copious Alphabetical Index. By William Grimshaw, author of a History of England, &c.

Also, QUESTIONS adapted to the above History, and a KEY, adapted to the Questions, for the use of Teachers.

*"University of Georgia, Athens, June 4,
1825.*

"DEAR SIR,

"With grateful pleasure, I have read the two small volumes of Mr. Grimshaw, (a History of England, and a History of the United States) which you some time since placed in my hands. On a careful perusal of them, I feel no difficulty in giving my opinion, that they

are both, as to style and sentiment, works of uncommon merit in their kind; and admirably adapted to excite, in youthful minds, the love of historical research.

"With sincere wishes for the success of his literary labours,

"I am very respectfully, your friend,
"M. WADDEL, *President*.

"E. JACKSON, Esq."

"D. JAUDON presents his respectful compliments to Mr. Grimshaw, and is much obliged by his polite attention, and the handsome compliment of his *History of the United States with the Questions and Key*.

"Mr. J. has been in the use of this book for some time; but anticipates still more pleasure to himself, and profit to his pupils, in future, from the help and facility which the questions and key will afford in the study of these interesting pages.

"*October 10th, 1822.*"

Golgotha, P. Edwd. Va. Sep. 26, 1820.

"DEAR SIR,

"MR. GRIMSHAW'S '*History of the United States*,' &c. was some time ago put into my hands by Mr. B—, who requested me to give you my opinion as to the merits of the work. The history of the late war is well managed by your author: it has more of detail and interest than the former part; and I consider it much superior to any of the many compilations on that subject, with which the public has been favoured. It may be said of the entire performance, that it is decidedly the best chronological series, and the chastest historical narrative, suited to the capacity of the juvenile mind, that has yet appeared. Its arrangement is judicious; its style neat, always perspicuous, and often elegant; and its principles sound.

"American writings on men and things connected with America, have been long needed for the young; and I am happy to find, that Mr. Grimshaw has not only undertaken to supply this want, but also to *Americanise* foreign history for the use of our schools. In a word, sir, I am so fond of American fabrics, and so anxious to show myself humbly instrumental in giving our youth American feeling and character whilst at school; that I shall without hesitation recommend Mr. Grimshaw's works to my young pupils, as introductory to more extensive historical reading. In fine, the work is so unobjectionable, and puts so great a mass of necessary information within the reach of school-boys, at so cheap a rate, that I feel the highest pleasure in recommending it to the public, and wish you extensive sales.

"Yours respectfully,
"WILLIAM BRANCH, JR.

"MR. BENJAMIN WARNER,
"Philadelphia."

"*History of the United States, from their first settlement as Colonies, to the Peace of Ghent, &c.* By William Grimshaw, pp. 312, 12mo.

"This is the third time, within the space of two years, that we have had occasion to review a volume from the hand of Mr. Grimshaw. He writes with great rapidity; and improves as he advances. This is the most correctly written of all his productions. We could wish that a person so well formed for close, and persevering study, as he must be, might find encouragement to devote himself to the interests of literature."

"Mr. G. has our thanks for the best concise and comprehensive history of the United States which we have seen."

Theological Review, October, 1819.

"*History of England, from the first Invasion by Julius Cæsar, to the Peace of Ghent, &c. For the use of Schools.* By William Grimshaw. Philadelphia, 1819. Benjamin Warner. 12mo. pp. 300.

"We have copied so much of the title of this work, barely to express our decided

approbation of the book, and to recommend its general introduction into schools. It is one of the best books of the kind to be found, and is instructive even to an adult reader. We should be pleased that teachers would rank it among their class-books; for it is well calculated to give correct impressions, to its readers, of the gradual progress of science, religion, government, and many other institutions, a knowledge of which is beneficial in the present age. Among the many striking merits of this book, are, the perspicuity of the narrative, and chasteness of the style. It is with no little pleasure we have learned, that the author has prepared a similar history *of the United States*; a work long wanted, to fill up a deplorable chasm in the education of American youth."

Analectic Magazine, October, 1819.

"Philadelphia, 28 June, 1819.

"SIR—I have read with pleasure and profit your History of England. I think it is written with perspicuity, chasteness, and impartiality. Well written history is the best political instructor, and under a government in which it is the blessing of the country that the people govern, its pages should be constantly in the hands of our youth, and lie open to the humblest citizen in our wide-spread territories. Your book is eminently calculated thus to diffuse this important knowledge, and therefore entitled to extensive circulation; which I most cordially wish. With much respect,

"Your obedient servant,
"LANGDON CHEVES.

"WILLIAM GRIMSHAW, ESQ."

GRIMSHAW'S IMPROVED EDITION OF GOLDSMITH'S GREECE.

Among the numerous recommendations to this valuable School Book, are the following:—

Although there are many worthless School Books, there are but few which are equally impure and inaccurate with the original editions of Goldsmith's Histories, for the use of Schools. I congratulate both teachers and pupils upon the appearance of Mr. Grimshaw's edition of the "History of Greece," which has been so completely expurgated, and otherwise corrected, as to give it the character of a new work, admirably adapted to the purpose for which it is intended.

THOS. P. JONES,
*Professor of Mechanics in the Franklin
Institute of the State of Pennsylvania, and
late Principal of the North Carolina Female
Academy.*

Philadelphia, Sept. 5, 1826.

MR. JOHN GRIGG.

DEAR SIR—Agreeably to your request I have examined, with attention, "Goldsmith's Greece, revised and corrected, and a vocabulary of proper names appended, with prosodial marks, to assist in their pronunciation, by William Grimshaw;" and I feel a perfect freedom to say, that the correction of numerous grammatical and other errors, by Mr. Grimshaw, together with the rejection of many obscene and indelicate passages improper for the perusal of youth, gives this edition, in my opinion, a decided preference over the editions of that work heretofore in use.

The Questions and Key, likewise supplied by Mr. Grimshaw to accompany this edition, afford a facility for communicating instruction, which will be duly appreciated by every judicious teacher.

I am, Sir,
Yours truly,
THOS. T. SMILEY.

Philadelphia, Sept. 8, 1826.

The Editor of the United States Gazette, in speaking of this work, says—"Goldsmith's Greece, without a revision, is not calculated for schools; it abounds in errors, in indelicate description,

improper phrases, and is, indeed, a proof how very badly a good author can write, if indeed there is not much room to doubt Goldsmith ever composed the histories to which his name is attached. Mr. Grimshaw has adopted the easy descriptive style of that writer, retained his facts, connected his dates, and entirely and handsomely adapted his work to the school desk. The book of questions and the accompanying key, are valuable additions to the work, and will be found most serviceable to teacher and pupil.

"From a knowledge of the book, and some acquaintance with the wants of those for whom it was especially prepared, we unhesitatingly recommend Grimshaw's Greece as one of the best (in our opinion, the very best of) works of the kind that has been offered to the public."

THE UNITED STATES SPEAKER, compiled by T. T. Smiley

preferred generally to the Columbian Orator and Scott's Lessons, and works of that kind, by teachers who have examined it.

GOLDSMITH'S HISTORY OF GREECE,

improved by Grimshaw, with a Vocabulary of the Proper Names contained in the work, and the Prosodial Accents, in conformity with the Pronunciation of Lempriere—with Questions and a Key, as above.

GRIMSHAW'S ETYMOLOGICAL DICTIONARY AND EXPOSITOR OF THE ENGLISH LANGUAGE.

Transcriber's Note.

Spelling variations where there is no obviously preferred choice have been preserved, except as noted below. Irregularities include: "bason" and "basin;" derivatives of "enquire" and "inquire;" "learned" and "learnt;" "sidereal" and "siderial;" "sun-rise" and "sunrise;" "sun-set" and "sunset."

The original use of commas was preserved, except where explicitly noted below.

The original spelling of "pourtray" was preserved.

Both Roman and Arabic numerals are used to number the plates; the text was left as is.

Preserved the non-standard order in the index, where U comes after V.

Removed extra comma after "which" on page v: "about which the parts."

Changed "Sideral" to "Siderial" on page vi: "Solar, Siderial, and Equal."

Added comma after "Mrs. B." on page 9: "your assistance, my Dear Mrs. B., in a charge."

Changed "erroneous" to "erroneous" on page 10: "an erroneous conception."

Added comma after "Mrs. B." twice on page 23: "Yet surely, Mrs. B., there;" and "But, Mrs. B., if attraction."

Added commas before and after "Mrs. B." on page 25: "Pray, Mrs. B., do."

Changed "plate 6. fig. 5" to "plate 5. fig. 5" on page 65 in the body of the text and in the associated question, to designate the correct figure.

Changed "pullies" to "pulleys" on page 64: "a system of pulleys."

Changed "twelves" to "twelve" on page 65: "twelve times less."

Changed "stream" to "steam" on page 66: "expansive force of steam."

Changed "Pray Mrs. B," to "Pray, Mrs. B.," on page 68.

Changed "nonelastic" to "non-elastic" on page 70: "non-elastic like water."

Removed extra comma after "one" on page 73: "one would ultimately have prevailed."

Changed "eliptical" to "elliptical" on page 73: "elliptical or oval orbit."

Changed "eclipse" to "ellipsis" on page 73: "motion in an ellipsis."
Changed "elipsis" to "ellipsis" on page 75: "but an ellipsis."
Changed "fig. 4 plate 3" in the question on page 75 to "fig. 4. plate 6" to designate the correct figure.
Changed "day-light" to "daylight" on page 77: "see them by daylight."
Changed the second question numbered 40 to "41" from page 79.
Changed "eliptical" to "elliptical" on page 83: "they were elliptical."
Capitalised "Mercury" on page 83: "made upon Mercury."
Added question mark on page 84 after "those beautiful lines of Milton."
Removed repeated word, "it", on page 88: "provided it were steady."
Changed "aeriform" to "æiriform" on page 136 (in versions supporting full Latin-1 character set).
Changed "atmospherial" to "atmospheric" on page 139: "the atmospheric air."
Changed "rarifies" to "rarefies" on page 140: "heat rarefies air."
Changed "to day" to "to-day" on page 157: "our lesson to-day."
Changed "re-appearance" to "reappearance" on page 159: "reappearance of the sun."
Changed question 20 to "29" on page 174 to maintain proper sequence.
Changed "proportionably" to "proportionally" on page 198: "proportionally distinct."
Inserted comma after "Circle" on page 206 in the glossary entry for "Circle, Lesser."
Inserted period on page 207 at the end of the glossary entry for "Cylinder."
Changed "musisical" to "musical" on page 208 in the glossary entry for "Harmony."
Changed "perpendicular" to "perpendicular" on page 211: "perpendicular to each other."
Changed "oppoite" to "opposite" on page 212: "the opposite direction."
Capitalised "Aries" on page 215: "the first degree of Aries."
Change "jr." to "Jr." in the advertisement for "A Pleasing Companion ...": "By Jesse Torrey, Jr."

*** END OF THE PROJECT GUTENBERG EBOOK CONVERSATIONS ON NATURAL
PHILOSOPHY, IN WHICH THE ELEMENTS OF THAT SCIENCE ARE FAMILIARLY EXPLAINED

Updated editions will replace the previous one—the old editions will be renamed.

Creating the works from print editions not protected by U.S. copyright law means that no one owns a United States copyright in these works, so the Foundation (and you!) can copy and distribute it in the United States without permission and without paying copyright royalties. Special rules, set forth in the General Terms of Use part of this license, apply to copying and distributing Project Gutenberg™ electronic works to protect the PROJECT GUTENBERG™ concept and trademark. Project Gutenberg is a registered trademark, and may not be used if you charge for an eBook, except by following the terms of the trademark license, including paying royalties for use of the Project Gutenberg trademark. If you do not charge anything for copies of this eBook, complying with the trademark license is very easy. You may use this eBook for nearly any purpose such as creation of derivative works, reports, performances and research. Project Gutenberg eBooks may be modified and printed and given away—you may do practically ANYTHING in the United States with eBooks not protected by U.S. copyright law. Redistribution is subject to the trademark license, especially commercial redistribution.

START: FULL LICENSE
THE FULL PROJECT GUTENBERG LICENSE
PLEASE READ THIS BEFORE YOU DISTRIBUTE OR USE THIS WORK

To protect the Project Gutenberg™ mission of promoting the free distribution of electronic works, by using or distributing this work (or any other work associated in any way with the phrase "Project Gutenberg"), you agree to comply with all the terms of the Full Project

Section 1. General Terms of Use and Redistributing Project Gutenberg™ electronic works

1.A. By reading or using any part of this Project Gutenberg™ electronic work, you indicate that you have read, understand, agree to and accept all the terms of this license and intellectual property (trademark/copyright) agreement. If you do not agree to abide by all the terms of this agreement, you must cease using and return or destroy all copies of Project Gutenberg™ electronic works in your possession. If you paid a fee for obtaining a copy of or access to a Project Gutenberg™ electronic work and you do not agree to be bound by the terms of this agreement, you may obtain a refund from the person or entity to whom you paid the fee as set forth in paragraph 1.E.8.

1.B. “Project Gutenberg” is a registered trademark. It may only be used on or associated in any way with an electronic work by people who agree to be bound by the terms of this agreement. There are a few things that you can do with most Project Gutenberg™ electronic works even without complying with the full terms of this agreement. See paragraph 1.C below. There are a lot of things you can do with Project Gutenberg™ electronic works if you follow the terms of this agreement and help preserve free future access to Project Gutenberg™ electronic works. See paragraph 1.E below.

1.C. The Project Gutenberg Literary Archive Foundation (“the Foundation” or PGLAF), owns a compilation copyright in the collection of Project Gutenberg™ electronic works. Nearly all the individual works in the collection are in the public domain in the United States. If an individual work is unprotected by copyright law in the United States and you are located in the United States, we do not claim a right to prevent you from copying, distributing, performing, displaying or creating derivative works based on the work as long as all references to Project Gutenberg are removed. Of course, we hope that you will support the Project Gutenberg™ mission of promoting free access to electronic works by freely sharing Project Gutenberg™ works in compliance with the terms of this agreement for keeping the Project Gutenberg™ name associated with the work. You can easily comply with the terms of this agreement by keeping this work in the same format with its attached full Project Gutenberg™ License when you share it without charge with others.

1.D. The copyright laws of the place where you are located also govern what you can do with this work. Copyright laws in most countries are in a constant state of change. If you are outside the United States, check the laws of your country in addition to the terms of this agreement before downloading, copying, displaying, performing, distributing or creating derivative works based on this work or any other Project Gutenberg™ work. The Foundation makes no representations concerning the copyright status of any work in any country other than the United States.

1.E. Unless you have removed all references to Project Gutenberg:

1.E.1. The following sentence, with active links to, or other immediate access to, the full Project Gutenberg™ License must appear prominently whenever any copy of a Project Gutenberg™ work (any work on which the phrase “Project Gutenberg” appears, or with which the phrase “Project Gutenberg” is associated) is accessed, displayed, performed, viewed, copied or distributed:

This eBook is for the use of anyone anywhere in the United States and most other parts of the world at no cost and with almost no restrictions whatsoever. You may copy it, give it away or re-use it under the terms of the Project Gutenberg License included with this eBook or online at www.gutenberg.org. If you are not located in the United States, you will have to check the laws of the country where you are located before using this eBook.

1.E.2. If an individual Project Gutenberg™ electronic work is derived from texts not protected by U.S. copyright law (does not contain a notice indicating that it is posted with permission of the copyright holder), the work can be copied and distributed to anyone in the United States without paying any fees or charges. If you are redistributing or providing access to a work with the phrase “Project Gutenberg” associated with or appearing on the work, you must comply either with the requirements of paragraphs 1.E.1 through 1.E.7 or obtain permission for the use of the work and the Project Gutenberg™ trademark as set forth in paragraphs 1.E.8 or 1.E.9.

1.E.3. If an individual Project Gutenberg™ electronic work is posted with the permission of the copyright holder, your use and distribution must comply with both paragraphs 1.E.1 through 1.E.7 and any additional terms imposed by the copyright holder. Additional terms will be linked to the Project Gutenberg™ License for all works posted with the permission of the copyright holder found at the beginning of this work.

1.E.4. Do not unlink or detach or remove the full Project Gutenberg™ License terms from this work, or any files containing a part of this work or any other work associated with Project Gutenberg™.

1.E.5. Do not copy, display, perform, distribute or redistribute this electronic work, or any part of this electronic work, without prominently displaying the sentence set forth in paragraph 1.E.1 with active links or immediate access to the full terms of the Project Gutenberg™ License.

1.E.6. You may convert to and distribute this work in any binary, compressed, marked up, nonproprietary or proprietary form, including any word processing or hypertext form. However, if you provide access to or distribute copies of a Project Gutenberg™ work in a format other than “Plain Vanilla ASCII” or other format used in the official version posted on the official Project Gutenberg™ website (www.gutenberg.org), you must, at no additional cost, fee or expense to the user, provide a copy, a means of exporting a copy, or a means of obtaining a copy upon request, of the work in its original “Plain Vanilla ASCII” or other form. Any alternate format must include the full Project Gutenberg™ License as specified in paragraph 1.E.1.

1.E.7. Do not charge a fee for access to, viewing, displaying, performing, copying or distributing any Project Gutenberg™ works unless you comply with paragraph 1.E.8 or 1.E.9.

1.E.8. You may charge a reasonable fee for copies of or providing access to or distributing Project Gutenberg™ electronic works provided that:

- You pay a royalty fee of 20% of the gross profits you derive from the use of Project Gutenberg™ works calculated using the method you already use to calculate your applicable taxes. The fee is owed to the owner of the Project Gutenberg™ trademark, but he has agreed to donate royalties under this paragraph to the Project Gutenberg Literary Archive Foundation. Royalty payments must be paid within 60 days following each date on which you prepare (or are legally required to prepare) your periodic tax returns. Royalty payments should be clearly marked as such and sent to the Project Gutenberg Literary Archive Foundation at the address specified in Section 4, “Information about donations to the Project Gutenberg Literary Archive Foundation.”
- You provide a full refund of any money paid by a user who notifies you in writing (or by e-mail) within 30 days of receipt that s/he does not agree to the terms of the full Project Gutenberg™ License. You must require such a user to return or destroy all copies of the works possessed in a physical medium and discontinue all use of and all access to other copies of Project Gutenberg™ works.
- You provide, in accordance with paragraph 1.F.3, a full refund of any money paid for a work or a replacement copy, if a defect in the electronic work is discovered and reported to you within 90 days of receipt of the work.
- You comply with all other terms of this agreement for free distribution of Project Gutenberg™ works.

1.E.9. If you wish to charge a fee or distribute a Project Gutenberg™ electronic work or group of works on different terms than are set forth in this agreement, you must obtain permission in writing from the Project Gutenberg Literary Archive Foundation, the manager of the Project Gutenberg™ trademark. Contact the Foundation as set forth in Section 3 below.

1.F.

1.F.1. Project Gutenberg volunteers and employees expend considerable effort to identify, do copyright research on, transcribe and proofread works not protected by U.S. copyright law in creating the Project Gutenberg™ collection. Despite these efforts, Project Gutenberg™ electronic works, and the medium on which they may be stored, may contain “Defects,” such as, but not limited to, incomplete, inaccurate or corrupt data, transcription errors, a copyright or other intellectual property infringement, a defective or damaged disk or other medium, a computer virus, or computer codes that damage or cannot be read by your equipment.

1.F.2. LIMITED WARRANTY, DISCLAIMER OF DAMAGES - Except for the “Right of Replacement or Refund” described in paragraph 1.F.3, the Project Gutenberg Literary Archive Foundation, the owner of the Project Gutenberg™ trademark, and any other party distributing a Project Gutenberg™ electronic work under this agreement, disclaim all liability to you for damages, costs and expenses, including legal fees. YOU AGREE THAT YOU HAVE NO REMEDIES FOR NEGLIGENCE, STRICT LIABILITY, BREACH OF WARRANTY OR BREACH OF CONTRACT EXCEPT THOSE PROVIDED IN PARAGRAPH 1.F.3. YOU AGREE THAT THE FOUNDATION, THE TRADEMARK OWNER, AND ANY DISTRIBUTOR UNDER THIS AGREEMENT WILL NOT BE LIABLE TO YOU FOR ACTUAL, DIRECT, INDIRECT, CONSEQUENTIAL, PUNITIVE OR INCIDENTAL DAMAGES EVEN IF YOU GIVE NOTICE OF THE POSSIBILITY OF SUCH DAMAGE.

1.F.3. LIMITED RIGHT OF REPLACEMENT OR REFUND - If you discover a defect in this electronic work within 90 days of receiving it, you can receive a refund of the money (if any) you paid for it by sending a written explanation to the person you received the work from. If

you received the work on a physical medium, you must return the medium with your written explanation. The person or entity that provided you with the defective work may elect to provide a replacement copy in lieu of a refund. If you received the work electronically, the person or entity providing it to you may choose to give you a second opportunity to receive the work electronically in lieu of a refund. If the second copy is also defective, you may demand a refund in writing without further opportunities to fix the problem.

1.F.4. Except for the limited right of replacement or refund set forth in paragraph 1.F.3, this work is provided to you 'AS-IS', WITH NO OTHER WARRANTIES OF ANY KIND, EXPRESS OR IMPLIED, INCLUDING BUT NOT LIMITED TO WARRANTIES OF MERCHANTABILITY OR FITNESS FOR ANY PURPOSE.

1.F.5. Some states do not allow disclaimers of certain implied warranties or the exclusion or limitation of certain types of damages. If any disclaimer or limitation set forth in this agreement violates the law of the state applicable to this agreement, the agreement shall be interpreted to make the maximum disclaimer or limitation permitted by the applicable state law. The invalidity or unenforceability of any provision of this agreement shall not void the remaining provisions.

1.F.6. INDEMNITY - You agree to indemnify and hold the Foundation, the trademark owner, any agent or employee of the Foundation, anyone providing copies of Project Gutenberg™ electronic works in accordance with this agreement, and any volunteers associated with the production, promotion and distribution of Project Gutenberg™ electronic works, harmless from all liability, costs and expenses, including legal fees, that arise directly or indirectly from any of the following which you do or cause to occur: (a) distribution of this or any Project Gutenberg™ work, (b) alteration, modification, or additions or deletions to any Project Gutenberg™ work, and (c) any Defect you cause.

Section 2. Information about the Mission of Project Gutenberg™

Project Gutenberg™ is synonymous with the free distribution of electronic works in formats readable by the widest variety of computers including obsolete, old, middle-aged and new computers. It exists because of the efforts of hundreds of volunteers and donations from people in all walks of life.

Volunteers and financial support to provide volunteers with the assistance they need are critical to reaching Project Gutenberg™'s goals and ensuring that the Project Gutenberg™ collection will remain freely available for generations to come. In 2001, the Project Gutenberg Literary Archive Foundation was created to provide a secure and permanent future for Project Gutenberg™ and future generations. To learn more about the Project Gutenberg Literary Archive Foundation and how your efforts and donations can help, see Sections 3 and 4 and the Foundation information page at www.gutenberg.org.

Section 3. Information about the Project Gutenberg Literary Archive Foundation

The Project Gutenberg Literary Archive Foundation is a non-profit 501(c)(3) educational corporation organized under the laws of the state of Mississippi and granted tax exempt status by the Internal Revenue Service. The Foundation's EIN or federal tax identification number is 64-6221541. Contributions to the Project Gutenberg Literary Archive Foundation are tax deductible to the full extent permitted by U.S. federal laws and your state's laws.

The Foundation's business office is located at 809 North 1500 West, Salt Lake City, UT 84116, (801) 596-1887. Email contact links and up to date contact information can be found at the Foundation's website and official page at www.gutenberg.org/contact

Section 4. Information about Donations to the Project Gutenberg Literary Archive Foundation

Project Gutenberg™ depends upon and cannot survive without widespread public support and donations to carry out its mission of increasing the number of public domain and licensed works that can be freely distributed in machine-readable form accessible by the widest array of equipment including outdated equipment. Many small donations (\$1 to \$5,000) are particularly important to maintaining tax exempt status with the IRS.

The Foundation is committed to complying with the laws regulating charities and charitable donations in all 50 states of the United States. Compliance requirements are not uniform and it takes a considerable effort, much paperwork and many fees to meet and keep up with these requirements. We do not solicit donations in locations where we have not received written confirmation of compliance. To SEND DONATIONS or determine the status of compliance for any particular state visit www.gutenberg.org/donate.

While we cannot and do not solicit contributions from states where we have not met the solicitation requirements, we know of no prohibition against accepting unsolicited donations from donors in such states who approach us with offers to donate.

International donations are gratefully accepted, but we cannot make any statements concerning tax treatment of donations received from outside the United States. U.S. laws alone swamp our small staff.

Please check the Project Gutenberg web pages for current donation methods and addresses. Donations are accepted in a number of other ways including checks, online payments and credit card donations. To donate, please visit: www.gutenberg.org/donate

Section 5. General Information About Project Gutenberg™ electronic works

Professor Michael S. Hart was the originator of the Project Gutenberg™ concept of a library of electronic works that could be freely shared with anyone. For forty years, he produced and distributed Project Gutenberg™ eBooks with only a loose network of volunteer support.

Project Gutenberg™ eBooks are often created from several printed editions, all of which are confirmed as not protected by copyright in the U.S. unless a copyright notice is included. Thus, we do not necessarily keep eBooks in compliance with any particular paper edition.

Most people start at our website which has the main PG search facility: www.gutenberg.org.

This website includes information about Project Gutenberg™, including how to make donations to the Project Gutenberg Literary Archive Foundation, how to help produce our new eBooks, and how to subscribe to our email newsletter to hear about new eBooks.