

The Project Gutenberg eBook of Motor Truck Logging Methods, by Frederick Malcolm Knapp

This ebook is for the use of anyone anywhere in the United States and most other parts of the world at no cost and with almost no restrictions whatsoever. You may copy it, give it away or re-use it under the terms of the Project Gutenberg License included with this ebook or online at www.gutenberg.org. If you are not located in the United States, you'll have to check the laws of the country where you are located before using this eBook.

Title: Motor Truck Logging Methods

Author: Frederick Malcolm Knapp

Release date: September 8, 2011 [EBook #37359]
Most recently updated: January 8, 2021

Language: English

Credits: Produced by Harry Lamé, Greg Bergquist and the Online Distributed Proofreading Team at <https://www.pgdp.net> (This file was produced from images generously made available by The Internet Archive/American Libraries.)

*** START OF THE PROJECT GUTENBERG EBOOK MOTOR TRUCK LOGGING METHODS ***

Please see the [Transcriber's Notes](#) at the end of the document.

The Engineering Experiment Station of the University of Washington was established in December, 1917, in order to coordinate investigations in progress and to facilitate the development of engineering and industrial research in the University. Its purpose is to aid in the industrial development of the state and nation by scientific research and by furnishing information for the solution of engineering problems.

The scope of the work is twofold:—

- (a) To investigate and to publish information concerning engineering problems of a more or less general nature that would be helpful in municipal, rural and industrial affairs.
- (b) To undertake extended research and to publish reports on engineering and scientific problems.

The control of the Station is vested in a Station Staff consisting of the President of the University, the Dean of the College of Engineering as ex-officio Director, and seven members of the Faculty. The Staff determines the character of the investigations to be undertaken and supervises the work. For administrative purposes the work of the Station is organized into seven divisions—

1. Forest Products
2. Mining and Metallurgy
3. Chemical Engineering and Industrial Chemistry
4. Civil Engineering
5. Electrical Engineering
6. Mechanical Engineering
7. Physics Standards and Tests

The results of the investigations are published in the form of bulletins. Requests for copies of the bulletins and inquiries for information on engineering and industrial problems should be addressed to the Director, Engineering Experiment Station, University of Washington, Seattle.

BULLETIN UNIVERSITY OF WASHINGTON ENGINEERING EXPERIMENT STATION

MOTOR TRUCK LOGGING METHODS

BY
FREDERICK MALCOLM KNAPP
Student in the College of Forestry,
University of Washington.



SEATTLE, WASHINGTON
PUBLISHED QUARTERLY BY THE UNIVERSITY
APRIL, 1921

Entered as second class matter, at Seattle, under the Act
of July 16, 1894.

CONTENTS

[3]

	Page
INTRODUCTION	5
HISTORY OF TRUCK LOGGING	5
First use of motor truck in logging—Development of logging trailer—Possibilities in the use of motor trucks.	
TRANSPORTATION OF LOGS—RAILROADS VERSUS MOTOR TRUCKS	7
Comparative advantages and uses of motor trucks and railroads—Relative cost of road construction—Advantage of flexibility of motor trucks.	
COSTS	8
Operating costs of a typical 5-ton truck—Actual cash outlay—Total expense—Variable charges—Recapitulation of work performed.	
ROLLING STOCK EQUIPMENT	10
Rigid versus flexible truck bodies—Chain drive versus worm drive—Weight of trucks—Speed—Depreciation.	
INSURANCE	14
Fire and theft insurance—Collision insurance—Liability insurance—Property damage insurance.	
TRUCK EQUIPMENT	14
Bunks—Tires—Relative advantages of different types of tires—Laws governing operation of motor vehicles—Legal limit of weight of load—Chain drives—Tops.	
TRAILERS	17
Draw-bar pull of motor trucks—Effect of grades on draw-bar pull—Advantage of trailer—Description of trailer—Brakes on trailer—Air brakes on trailers.	
LIFE AND DEPRECIATION	20
COST DATA	20
Operating expenses for 3½ and 5-ton trucks—Fixed charges—Total expenses.	
ROAD CONSTRUCTION	24
Sub-grade—Cross-plank roads—Fore and aft pole roads	

[4]

BRIDGES	36
TURNING DEVICES AND TURNOUTS	37
Construction of turn-tables — Turning of trucks .	
TELEPHONES	39
INCLINES	39
Snubbing methods — Practicability of inclines .	
YARDING	41
LOADING AND UNLOADING	41
Methods of loading trucks — Loading with boom — Rigging of boom — Unloading .	
TIME STUDIES	45
CONCLUSION	46
Future use of the motor truck — Motor trucks and forestry .	
BIBLIOGRAPHY	48

INTRODUCTION

[5]

In this paper an attempt has been made to bring together some useful facts concerning the application of the motor truck to the logging industry. The term “motor truck” as here used is applied to the ordinary truck type of motor vehicle with trailer adapted to carrying logs, and does not include the “tractor” and the “caterpillar tractor.” These latter types present special problems of their own. In the following pages the discussion of motor truck logging is premised upon conditions as they exist in the forests of the Pacific Northwest.

HISTORY OF TRUCK LOGGING

Motor trucks in the logging industry are a comparatively recent development. As nearly as can be determined, the first use of a truck in a logging operation was made in this region by Palms and Shields near Covington, Washington, in the spring of 1913. Since that time various types of road construction suitable for heavy trucks have been devised and the use of the motor truck for logging has steadily increased until at the present time there are about six hundred trucks operating in the woods in the Northwest.

The first real progress in the use of the motor truck for logging purposes came with the development of the trailer. Although the motor truck has been brought to its present high state of perfection in eastern factories the problem of adapting it to the hauling of massive logs was solved in Seattle, Washington, with the perfecting of a trailer which could carry unprecedented loads and stand up under the speed attained by a motor truck. In the early attempts to design a trailer, it was found that too great tractive effort on the part of the truck was required if the trailer was patterned after older types with simply increased dimensions in all of its parts. Through successive improvements the modern form of heavy duty trailer was finally evolved. It has solved a serious problem by permitting the hauling of heavier weights with the aid of the trailer than is possible with the use of the truck alone. With the help of the trailer and an adjustable reach, the motor truck has successfully entered the logging field.

In the Pacific Northwest tracts of timber of sufficient area well situated for economical logging by old established methods are no longer plentiful. Almost every logging chance which exists today presents its own peculiar conditions and individual problems. An operator must therefore analyze the situation thoroughly before arriving at a decision as to the most economical logging methods that will apply in any particular case. Even in different sections of the same operation it is often necessary to use different methods. Since proper cost accounting systems are not usually kept by logging companies, particularly the smaller concerns, these companies often do not know that they are losing money upon one part of an operation because the success of the whole absorbs this loss.

[6]

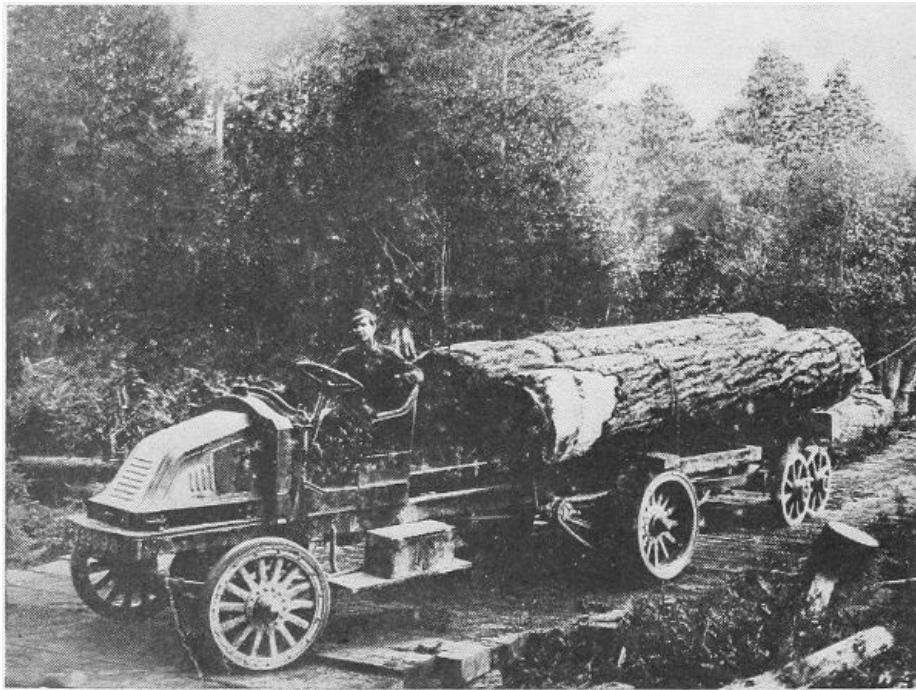

Pioneer logging with a motor truck in 1913.

The use of a motor truck has proved to be practicable in many instances, and bids fair to become of increasing importance. It will therefore be advantageous for every operator to inquire into its possible applications. It should be emphasized, however, that the motor truck is not economically adapted to all conditions. There have been many failures. Each projected application of the motor truck in the logging field must be thoroughly analyzed and if a doubt as to its successful performance exists, expert advice should be sought.

TRANSPORTATION OF LOGS—RAILROADS VERSUS MOTOR TRUCKS

[7]

The principal methods of transporting logs are by rail, by motor truck and by animal power. The last of these methods is, for obvious reasons, impracticable in the Northwest, and so needs no further comment. While it is impossible to give specific details in a general discussion of this kind to show where the motor truck may be more economically suited to the conditions at hand than the railroad, a comparison of the fundamental principles involved should enable any operator familiar with logging to determine whether or not to use the truck for his particular chance.

In general the choice between railroad and motor truck logging depends, fundamentally, upon two things: (1) comparative cost, and (2) adaptability. Sufficient motive power and rolling stock can be obtained much more cheaply for motor truck logging than for a railroad. There are, of course, many situations where the locomotive and car costs, as well as those of constructing a logging railroad, are obviously prohibitive, and the question revolves entirely upon the adaptability of the motor truck to existing conditions. There is no question at all that the logging railroad is not adapted to small, isolated and scattering tracts, and to certain portions of larger operations. There are almost innumerable tracts situated close to public highways, or where temporary roads can be built, which may be very serviceable during the summer months, giving ample time to clean up the timber before wet weather sets in. In such instances, road construction and maintenance costs are of very minor importance. In the larger operations and in the use of the motor truck as an auxiliary to railroad logging, there are many opportunities for the reduction of logging costs. However, it is impossible to discuss these problems specifically in a paper of this kind. They will need to be worked out on the ground with each case as a distinct problem. The fundamental problems covered in this paper will serve as a basis for the more detailed problems that must be solved on the ground.

Wherever the item of road construction is important, it may be stated in general that the time required and the cost of building roads for motor trucks are very much less than for a logging railroad. This is due to the lesser importance of grades, curves, ballasting, bridges and other construction work, all of which is much cheaper and takes less time. In case a pole road is built the material found adjacent to the right of way can be utilized for what it costs to fell it.

[8]

From the standpoint of adaptability the motor truck is very flexible. It can operate on grades and curves that are impossible with the railroad. The whole logging equipment, including the donkey engine, can be loaded on the truck and trailer and easily moved from one setting to another. By replacing the log bunk with a platform the truck can take out all the smaller marketable material, such as shingle bolts, poles and cordwood. The modern truck can also be provided with the necessary equipment for use in snaking out the logs in stands of small timber and when used

with a winch and an "A" shaped boom, will load itself. If the truck becomes mired in a mud hole, the winch may be used to pull it out. Finally, the item of fire risk is practically negligible.

COSTS

In order to arrive at definite figures as a basis for a comparison between railroad and motor truck transportation costs, the following case is cited as an example representing average good conditions:^[1] A 5-ton truck with trailer was used, operating on a seven and one-half mile haul over ordinary unpaved roads. An average of four trips a day were made and the actual running expense for hauling was \$.90½ per thousand feet. Adding to this the overhead expenses of interest, depreciation, etc., the total cost of hauling was \$1.44 per thousand feet. The statement of this cost is as follows:

[1] West Coast Lumberman. Nov. 1, 1916, page 266. Labor, gas and oil have since advanced in cost.

ACTUAL CASH OUTLAY IN HAULING 128,420 BOARD FEET OF LOGS

Gasoline, 284 gallons @ \$.19	\$53.96
Oil, 3 gallons @ \$.60	1.80
Oil, 20½ gallons @ \$.45	9.23
Incidentals—One electric light globe	.35
Hardware	4.03
Blacksmith	3.00
Driver, 11 days @ \$4.00	44.00
Total	\$116.37

128,420 feet @ \$116.37, or \$.90½ per thousand feet.

TOTAL EXPENSE OF HAULING 128,420 BOARD FEET OF LOGS

[9]

Investment:

Chassis	\$4,900.00
Trailer	700.00
Total Investment	\$5,600.00

VARIABLE CHARGES

Gasoline, 284 gallons @ \$.19	\$53.96
Oil, 3 gallons @ \$.60	1.80
Oil, 20½ gallons @ \$.45	9.23
Tires, \$.07½ per mile on 615 miles	46.12
Incidentals	7.43
Total variable charges	\$118.54

Depreciation (based on 15% per annum on \$5,600, less \$560, the cost of the tires, or \$5,040.00)	\$1.349
Interest on amortized value at 7%	.63
Storage, \$5.00 a month	.20
Driver @ \$4.00 a day	4.00
Total fixed charges	\$6.179

Total variable charges	\$118.54
Total fixed charges at \$6.179 a day for 11 days	67.97
Total cost	\$186.51

128,420 board feet of logs @ \$186.51, or \$1.44 per 1000 feet.

Following is a recapitulation of the work performed by a 5-ton logging truck, Jan. 20 to Jan. 31, 1916, inclusive. The logs were hauled from O'Neill's Camp on the Bothell-Everett road 7½ miles and dumped into Lake Washington at Bothell.

Date	Trips	Mileage	No. Ft. Hauled	Gas Used	Oil Used
1/20/16	4	60	10,768	30	2.25

1/21/16	4	60	11,888	24	2.25
1/22/16	4	60	11,707	30	2.25
1/23/16	Did not haul. Roads in bad condition.				
1/24/16	4	60	8,894	34	2.25
1/25/16	2	30	5,200	16	[2]1.00
1/26/16	4	60	16,174	29	2.25
1/27/16	4	60	11,276	25	2.25
1/28/16	4	60	15,514	26	2.25
1/29/16	4	60	15,511	31	2.25
1/30/16	3	45	9,152	20	[3]2.25
1/31/16	4	60	12,336	19	2.25
Total	41	615	128,420	284	23.50

[10]

[2] Freight truck in the ditch. Four hours lost getting the road cleared.

[3] Two hours lost at the landing due to a spring slipping out of place, which made it necessary to unload and load again.

Many loggers who have used both the steam railroad and the motor truck claim that the latter is preferable in some cases and often is the only method by means of which logs can be gotten to the mill at a reasonable cost. Where the stand is scattered and of poor quality, the building of a railroad is not practical. In such a case the motor truck may offer the only solution.

The motor truck makes the best showing when hauling from one "side." With a two or three side operation the railroad is by far the more practical. It must be remembered, however, that the railroad and the motor truck are not competitors in the logging industry—they are allies.

ROLLING STOCK EQUIPMENT

In general two plans are followed in building a motor truck. The first is to build a rigid truck so that it will resist all shocks and distortions that come from rough and uneven roads. The second plan is to build a flexible body so that the chassis will "give" rather than resist when subjected to hard strains. Although the rigidly-built truck may be entirely satisfactory for most forms of trucking, it is practically impossible to build one on the rigid principle that will stand up under the heavy strains to which a logging truck is subjected unless it is to be operated over good paved roads. When only ordinary unpaved public roads are available, flexibility is one of the most important characteristics to look for when selecting a truck. Where the operator is hauling over his own pole or plank road this consideration does not play so important a part, as the road bed then is more likely to be free from holes and irregularities.

All makes of trucks are more or less alike in general construction, differing only in minor details, so that the personal whims of the buyer will largely determine the kind he will select. It is advantageous to have as long a distance as possible between the driver's seat and the bunk over the rear axle, in order to allow more of the load to be carried by the truck, and less by the trailer, giving better traction to the drive wheels, but necessitating extra strong rear springs and axles.

[11]

The type of power transmission best suited to the use of the logging truck is a question that has received a great deal of attention. There are three general methods of transmitting the power: (1) by chain; (2) by worm drive, and (3) by internal gear drive. Each has its advantages. It is claimed by many that the chain drive saves many hours of "shut-down time" due to the fact that if anything breaks in the transmission, it will be a link in the chain as this is the weakest point. It is then only a matter of a few minutes to insert another link. With the worm driven vehicle, a break in the transmission requires an expensive shut-down before the matter can be repaired. The worm drive, on the other hand, very seldom breaks if proper care is used.

The chain drive also allows the replacement of the sprocket with one of a larger or smaller diameter thereby giving a higher or lower gear ratio, which cannot be done with the worm gear. This seems to be of some advantage to an operator when changing his setting from one with a short haul and steep grades where a low gear ratio is required, to one where the haul is long and fairly level, and where speed in transit is an advantage.

On the other hand, in starting on slippery grades or wherever the traction is poor, the worm drive will give better traction than a chain drive because there is difficulty in taking up the slack that is always present in the chain before letting in the clutch fully. The slightest jerk given to the wheels when the slack is taken up is likely to cause them to spin, thereby losing all the tractive power of the drive wheels. In the worm gear there is no slack to take up and the power can be applied more gradually, thus reducing the chances of spinning the wheels and losing the traction.

The question of the weight of the truck used for logging purposes is not as important now as it will be in the future. Laws are being passed in nearly every state limiting the maximum weight to be carried on each wheel by trucks using state or county roads so that the total weight of the truck without load will be important. When operating over state or county roads the load is limited to from 2400 to 3000 feet, B. M., of Douglas fir, depending upon the locality. In such cases, it is an advantage to have a lighter truck, say one of 3½ tons capacity. By adding

[12]

additional leaves to the rear springs of a truck of this capacity it may be made to carry a larger load than it would be possible to put on a 5-ton truck and still comply with the law. The pulling power of the 3½-ton truck and the 5-ton truck is practically the same so that the difference in dead weight between the two may be carried in a profitable manner by adding four or five hundred feet B. M. of logs. Another advantage of the lighter weight truck is *speed*. The 3½-ton truck is geared to make from 14 to 16 miles an hour, while the 5-ton truck is usually limited to from 10 to 12 miles an hour.

Whenever the legal weight limit does not enter into the problem, as in operating over a pole or plank road for the entire distance, it is, of course, advantageous to carry the largest loads possible. In such cases a 5-ton truck with an 8½-ton trailer is the most profitable investment. This allows a much larger load to be carried in proportion to the overhead charges. The disadvantage of the 5-ton truck is that it is very heavy and unless the roads are good, it will easily sink into the ground and cause trouble. A common fault of the 5-ton truck today is the overweight of the front end, which is too heavy for the width of tire on the front wheels. This can be very easily overcome by the use of wider tires.

LIFE AND DEPRECIATION

The life of a truck is directly proportional to the care that it receives, hence, a good driver is a most important consideration. If the right man can be secured his wages should be a secondary consideration.

The charge to be made for the depreciation of a truck is an uncertain question. Some loggers figure on the basis of four and a half years, others on as much as seven years. The depreciation charge on a truck used in the logging industry should depend largely upon the type of road over which it is operated. Loggers in general over-rate the life of their equipment because they do not fully realize the severity of the work. Over a fore and aft plank road or a cement road, where the jar and vibration are reduced to a minimum, the wear and tear on the equipment is very much less than where the truck is operated over a cross-plank road or an unpaved public road. The matter of depreciation, then, will depend largely upon the type of road over which the truck is to operate. In general a four-year depreciation charge less 25% sale value at the end of that time should be used as a basis for figuring costs unless the hauling conditions are very favorable. Only under very rare circumstances should more than four years be allowed. It should be remembered that the depreciation on a truck is very heavy during the first year, and the sale value at the end of a year is only half the original price. Many truck operators now hauling over good roads who are depreciating on the basis of five years say that a four-year depreciation would be more nearly correct. Another factor in favor of a four-year depreciation charge is that methods of logging are changing constantly and that trucks in that time may be improved upon to such an extent that the use of the old equipment would be unprofitable and inefficient.

[13]

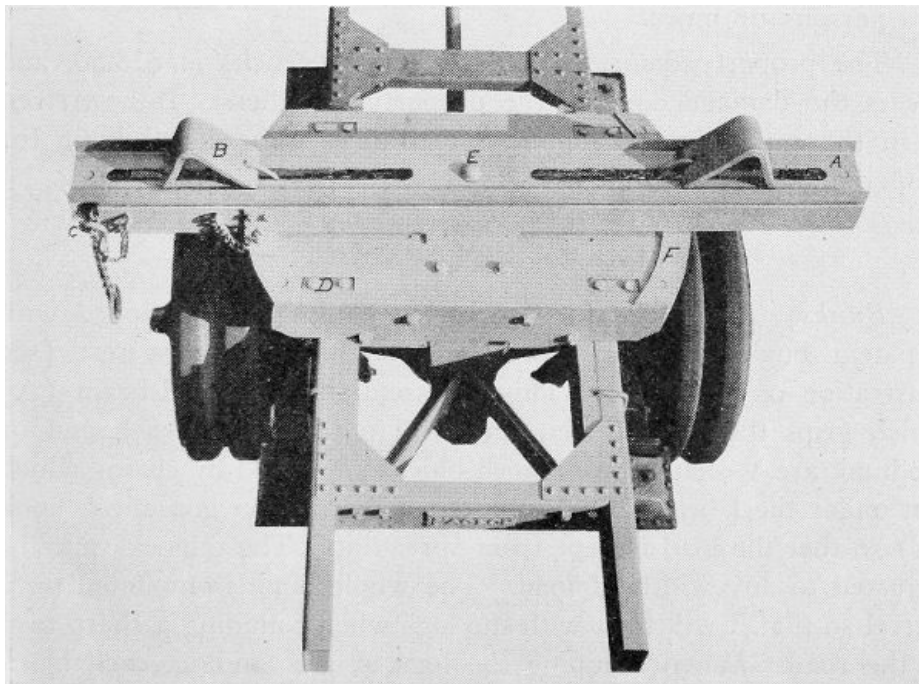

Swivel bunk on truck equipped for motor truck logging. The base on which the bunk rests is made of two heavy timbers about 18 inches by 24 inches in section and 4 feet long, bolted together and clamped to the frame of the truck by means of heavy N-bolts, (D). The bunk is fastened by a king-pin (E) to the base and is free to rotate upon a steel center plate and two side-bearing plates (F).

The insurance rates on trucks depend upon the use to which they are put. The insurance usually carried by loggers covers fire and theft, although some companies also carry liability and either collision or property damage insurance. The equipment can be insured for only ninety per cent of its value.

Fire and theft insurance is based upon the list price of the truck and body when new and the usual premium for the logging truck is one dollar for every hundred dollars of insured value. Theft rates on the trailer are based on a flat charge of twenty-five cents per hundred dollars of insurance taken, regardless of age, list price, etcetera.

Collision insurance is based upon the list price of the equipment and covers full value at the time of loss of the damage to the truck by colliding with anything movable or immovable.

The liability rate for logging trucks is \$33.75 and is based upon occupation alone. This covers the public as well as the employee and is limited to \$5,000 for one person and \$10,000 for two persons or more.

The property damage rate for logging trucks is \$13.50, and covers the damage done to the property of others. It is arrived at in the same way as liability insurance. The usual limit for property damage is \$1,000.

TRUCK EQUIPMENT

Bunks. All trucks for use in log hauling are equipped with a patent bunk over the rear axle on which the logs rest (see [illustration](#) on page 13). This is essentially a steel I-beam (A) which grips the logs so that they will not slip. At each end of the bunk are V-shaped iron chock-blocks (B) held by chains which run under the I-beam and are fastened by an iron gooseneck hook (C) so that the load is kept from spreading. These blocks may be adjusted to any width of load. The whole bunk is mounted on a swivel so that it will turn with the logs when rounding a sharp turn in the road. When dumping the logs at the landing, each block is loosened from the opposite side so that the danger of the logs rolling off on the men is greatly lessened.

Tires. Solid rubber tires are generally conceded to be the best suited for the heavy duty required in logging. The use of steel tires is rapidly declining. The jar on the equipment is in itself enough to condemn their use. Rubber tires double the mileage of a day's work, more than double the life of the equipment, allow the weight of the equipment to be cut in half, and work well on dirt, cement, or any other type of road. The saving on the life of a pole or plank road by the use of rubber tires is also an item of considerable importance. There are three general types of solid rubber tires in use on the logging truck: the so-called giant tires, the duals, and the non-skid or caterpillar tires. It is a question as to which of the three is the best. Traction for the drive wheels and also for the trailer wheels, if the latter are equipped with brakes, is the problem to be solved.

[15]

The duals are satisfactory with light loads and easy grades, on cement, brick, or other perfect surface road, but when the haul is heavy and the braking difficult on account of heavy grades, the larger single-tread giant tires are more efficient. During dry weather it is safe to work with the single-tread tires on grades as high as nine or ten per cent, but in wet weather a seven per cent grade should be the maximum unless some extra means are taken to secure traction, and even then the wheels will skid if particles of soil get on the surface of a plank road, unless chains are used or the wheel is wrapped with a light cable.^[4] For very heavy-duty trucking, where resiliency and long service are prime considerations, the giant type is rapidly superseding the old dual type as the former contains more rubber and gives more mileage with the least truck vibration.

[4] West Coast Lumberman. October, 1919. Page 25.

The non-skid or caterpillar tire may well be used on heavy grades or where the traction is very poor, the general opinion being that it gives a firmer grip on the road and makes it safer to handle the truck in wet weather.

There is no standard width of tread for truck wheels. The widths usually used on the drive wheels of the logging truck and the wheels of the trailer are twelve and fourteen inches, respectively. The use of tires of smaller width on either trailer or truck cannot be recommended. The wider the tires on the trailer, the better it is both for the life of the equipment and for ease in handling the load. When the surface of the giant tires becomes worn down so that the grooves become very shallow, it is desirable to have the tires re-grooved. They will last a great deal longer if this is done and will also give better traction on the road. The groove makes the tire lobes act separately on the uneven places in the road so that only one lobe is subjected to the strain of the irregularities instead of the whole tire. This is also true with reference to the strains that are set up internally due to the twisting of the rubber.

[16]

LAWS GOVERNING THE OPERATION OF MOTOR VEHICLES

The Laws governing the operation of motor vehicles upon the public highways of the State of Washington are contained and summarized in Senate Bill No. 220, Session of 1921 of the Legislature of the State of

Washington. They include the following provisions governing the operation of motor trucks and trailers:

(a) Chapter 153 of the laws of 1913 and Chapter 142 of the laws of 1915 are repealed.

(b) Motor truck vehicles weighing less than 1,500 pounds must pay an annual license fee of ten dollars (\$10.00); Trucks weighing more than 1,500 pounds and not to exceed 6,500 pounds, ten dollars (\$10.00) plus forty cents per hundredweight for all in excess of 1,500 pounds and in addition thereto fifty cents per hundredweight at the rated carrying capacity. Motor trucks weighing more than 6,500 pounds must pay a license fee of ten dollars (\$10.00) plus fifty cents per hundredweight for all in excess of 1,500 pounds and in addition thereto fifty cents per hundredweight at the rated carrying capacity. Trailers **used as trucks** shall be classified and rated as, and shall pay the same fees as hereinbefore provided for motor trucks of like weight and capacity.

(c) No vehicle of four wheels or less whose gross weight with load is over 24,000 pounds is permitted to operate over or along a public highway. Any vehicle having a greater weight than 22,400 pounds on one axle, or any vehicle having a combined weight of 800 pounds per inch-width of tire concentrated upon the surface of the highway (said width of tire in the case of solid rubber tires to be measured between the flanges of the rim) is also barred by the provisions of this law, with the following exception:

PROVIDED, that in special cases vehicles whose weight including loads whose weight exceeds those herein prescribed, may operate under special written permits, which must be first obtained and under such terms and conditions as to time, route, equipment, speed and otherwise as shall be determined by the director of licenses if it is desired to use a state highway; the county commissioners, if it is desired to use a county road; the city or town council, if it is desired to use a city or town street; from each of which officer or officers such permit shall be obtained in the respective cases. Provided, that no motor truck or trailer shall be driven over or on a public highway with a load exceeding the licensed capacity.

Chain Drive. Trucks equipped with a chain drive should be supplied with an extra set of chains so that they may be changed and cleaned every week. To clean the chains, they should be soaked in kerosene which removes the dirt, grease and gum that has accumulated. By doing this the life of the chains will be quadrupled. The small amount of time that it takes will pay.

Top. The truck should come equipped with a top over the driver's seat that is easily detachable. In bad weather the driver should be protected from the elements, but the top should be removed in good weather as it is in constant danger of being broken during loading. Many operators leave the top off entirely and the driver must dress for the weather. A good demountable top will add to the comfort of the men and often helps to keep a good man at his job.

TRAILERS

[17]

The development of the trailer has made motor truck logging practical. Every truck has greater tractive power than it can utilize in the propulsion of the ordinary load. Its limitations are due to a short-bulk carrying capacity and not to any lack of pulling power. The ordinary truck has a draw-bar pull of 2600 pounds. The draw-bar pull per ton of load varies from the minimum of 50 pounds on a level pavement to 250 pounds on a level dirt road, depending upon the character of surface.^[5] Twenty pounds of additional pull are required for each degree of gradient. For example, a fore and aft plank road offers a resistance of about 60 pounds pull to a ton of load. If this were located on a seven per cent grade, it would require a 60 pound pull to overcome the load resistance plus seven times twenty or 140 pounds additional pull for the grade, a total of 200 pounds to pull one ton. Dividing 2600, the draw-bar pull of the truck, by 200, the resistance offered by road and grade, gives 13 tons as the load that can be pulled by the truck over this surface and grade. As this must include the weight of the trailer, which when equipped for logging is about three tons, it leaves a total of 10 tons that the truck can pull. This is equivalent to about 3000 feet B. M. of Douglas fir logs, the average load that is hauled. While such an adverse grade as cited in this illustration is avoided if possible with a loaded truck, the illustration will serve to show the pulling capacity of the truck. The hauling of loads of this size would be impossible without the use of the trailer. The normal load, then, may be increased two, three, or even four times, by the use of the trailer, over the maximum load that can be carried by the truck alone.

[5] Operating Cost of Motor Truck Computed. Timberman. Feb., 1918. Page 60.

Objection to the trailer that it tends to shorten the life of the truck is hardly worth consideration. According to a careful analysis it has been estimated that the use of the trailer does not shorten the life of the truck by more than one year, which is of little consequence when the saving due to the size of the load that can be carried is taken into consideration.

Description of the Trailer. The frame of the trailer is constructed of heavy steel channel bars which support the twin bunks used for logging, and for the substructure to carry the body when used for other service. The steel frame is supported by semi-elliptic springs held by shackles similar to those of the truck. The springs rest securely upon the axle, are clamped to it by U-bolts, and are relieved from side stresses by radius rods which connect the axle to the frame.

[18]

The trailer is coupled to the truck by a reach which is passed through guides secured to the hounds of the trailer. The latter may slide upon the reach and is held in the desired position with reference to the truck by means of clamps. The hounds are located fore and aft of the axle and are connected to it by steel plates. The square reach is more favored generally by loggers than the round type for the reason that it can be more easily adjusted, particularly the round reach

that is cut in the woods, which is irregular and has to be clamped very tightly in order to make it stay in place. Holes bored through the square reach makes the adjustment easy. Combination steel and wood reaches, the sides being of channel iron and the center of wood, are favored by some operators.

The twin bunks of the trailer carry the load in balance upon the axle independent of the reach, thereby relieving the reach of all vertical stress. (See [illustration](#) below). The rear bunk is just an ordinary wooden affair designed only to help support the weight of the logs. The front bunk is of the same construction as the one on the truck (described [above](#)) and serves to hold the load in place.

[19]

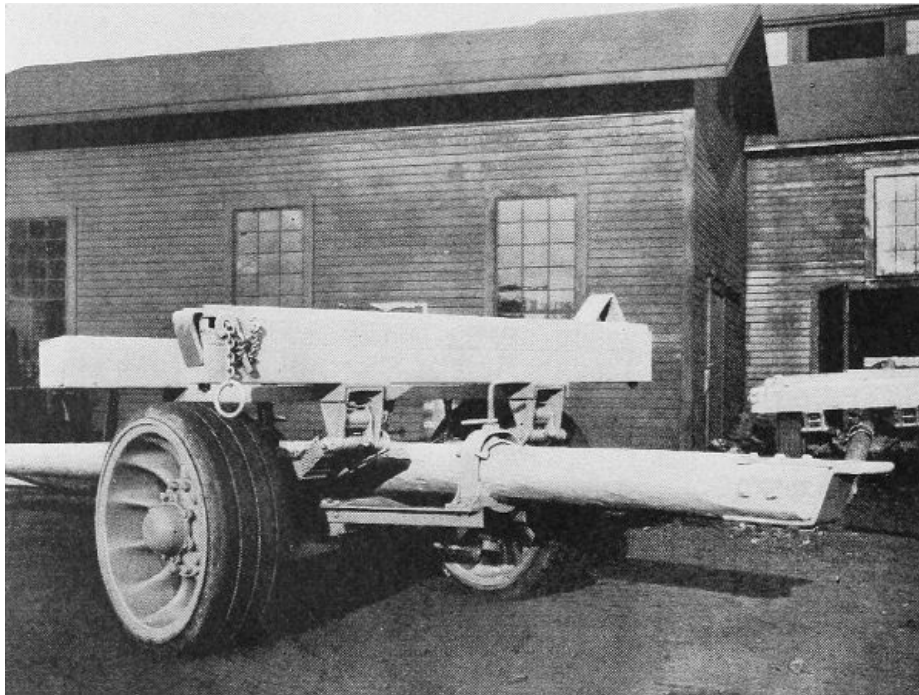

Type of trailer adapted for heavy Pacific coast logging.

The trailer is guided through the reach directly to the axles, thus relieving the springs and frame from side stresses. The springs and their suspension from the frame permit a limited movement of the frame and the load independent of the wheels and axles and vice versa. This enables the wheels to pass over an obstruction or drop into a hole without subjecting the trailer to shocks that would otherwise ensue.

Other types of trailers are used to a limited extent. The trailer described above was evolved by local engineers and is in almost universal use in motor truck logging operations.

Brakes. All trailers should be equipped with brakes when negotiating heavy grades. A device connecting the trailer brakes to the truck permits a ready control from the driver's seat on the truck. The brake outfit is easily attached to the truck and consists of a ratchet and lever which winds a one-quarter inch cable on a small drum. The cable winds around a second drum which is attached to the frame of the truck about six feet back of the driver's seat. A third drum in the center of the chassis attached to the shaft of the second drum winds a cable which goes to an equalizing bar just in front of the trailer brake. As the ratchet and drum are tightened, the motion is transmitted through the second and third drums to the equalizing bar. Two arms extend from this bar to roads which when pulled forward, move a bar attached to the road in such a way that the brake band in the inside of the brake shoe is extended against the shoe, applying the brakes evenly to each wheel no matter how uneven the road-bed or how sharp the curve. A spring attached to the reach clamp pulls back the equalizing bar when the brakes are released. A heavy spring on the drum in the center of the shaft on the truck allows for curves so that an even pressure is always maintained.

The use of a trailer equipped with brakes will do away with the numerous devices for snubbing a load of logs down a grade not steeper than twelve per cent. Grades up to this degree of steepness are safe to operate over in dry weather without added braking power if the trailer is properly equipped.

A simple and it is claimed an effective air brake for motor trucks and trailers is now being marketed by an air-brake concern of San Francisco but it has not yet been tried out in the logging industry. "Braking action is secured by means of a diaphragm and pressure plate. The diaphragm is directly connected to the brake-band lever. No air compressor is used in this system. A small air receiver or storage tank takes the spent gases from one of the cylinders by utilizing the outlet afforded by a priming cock. The brakes are applied by a control system mounted on the steering column. By means of a quickly adjusted hose connection, air can be applied to the wheels of the trailer using the control which governs the braking of the truck. The air pressure in the storage tank is automatically maintained by means of an accumulator valve which closes when the tank pressure reaches 150 to 175 pounds. If the tank should be empty at the top of a long grade, sufficient pressure is generated by the compression of the engine to

[20]

operate the brakes. Opening the throttle to full emergency position will apply maximum braking effect without sliding the wheels.”^[6]

[6] Air Brakes for Trucks. Timberman. March, 1920. Page 48g.

This system has not been tried out under the conditions as found in the woods but if it can be made to work satisfactorily it will be a big improvement over the old system as the driver will then have instantaneous control over the load at all times.

LIFE AND DEPRECIATION

The life of the trailer is about the same as that of the truck, and in depreciation, a period of four years is usually allowed. The maintenance and upkeep of the trailer is very low. It rarely gives out and with the ordinary usage requires only a few minor repairs every two or three years.

COST DATA

The items of expense are here segregated in such a manner that they may be used as a basis for figuring the cost of hauling logs under average conditions. These costs are for the truck and trailer as a unit. If a road has to be built, the overhead charge of the road per thousand feet of timber hauled over it together with the cost of upkeep must be added to the figures given below in order to know the total cost of transportation per thousand feet.

3000 FOOT CAPACITY, OUTFIT COMPLETE

[21]

The following figures are for a 3½-ton logging truck with a 5-ton trailer. The figures are based upon a 275 working day year.

Cost of equipment (as a basis)			\$6700.00
Less resale value at expiration of 4 years at 25% of the original cost		\$1675.00	
Less cost of tires,			
2—36" × 6"	\$140.50		
4—40" × 12"	776.00	916.50	
Total	\$916.50	\$2591.50	2591.50
Basis for computing			\$4108.50

RUNNING EXPENSES PER MILE

	Per Mile
Tires, based on a cost of \$916.50 and a life of 8000 miles	\$.1145
Gasoline, four miles to a gallon @ \$.28 per gal.	.07
Oil and grease	.02
General repairs	.03
Total running expenses per mile	\$.2345

FIXED CHARGES PER 275 WORKING DAY YEAR

Depreciation, based on 25% per year on \$4108.50	\$1027.12
Interest on money invested at 6% (figured on truck less cost of tires)	347.01
Driver at \$7.00 a day	1925.00
License	27.00
Insurance, Fire, Theft and Liability based on \$1 a hundred on 90% of the value of the new truck for fire and theft, and a flat rate of \$33.75 for liability	90.75
Total fixed charges for 275 day year	\$3416.88
Total fixed charges per day	12.418

[22]

TOTAL EXPENSES

	30	40	50	60	70
	miles	miles	miles	miles	miles
Uniform variable charges	\$ 7.035	\$ 9.38	\$11.725	\$14.07	\$16.415
Fixed charges	12.418	12.418	12.418	12.418	12.418
Total charges (per day)	19.453	21.798	24.143	26.488	28.833

Total cost per mile, loaded one way only	.648	.545	.482	.441	.412
Total cost per 1000 ft. per mile with 3000 ft. to the load	.216	.181	.160	.147	.137

4000 FOOT CAPACITY, OUTFIT COMPLETE

The following figures are for the 5-ton logging truck equipped with an 8½-ton trailer, based on a 275 working day year:

Cost of equipment (as a basis)			\$7600.00
Less resale value at expiration of four years at 25% of the original cost		\$1900.00	
Less cost of tires:			
2—36-in × 6-in	\$140.50		
4—40-in × 14-in	923.00	1063.50	
Total	\$1063.50	\$2963.50	2963.50
	Basis for computing		\$4636.50

RUNNING EXPENSES PER MILE

	per mile
Tires, based on cost of \$1063.50 and a life of 8000 miles	\$.129
Gasoline, 3½ miles to the gallon @ \$.28 per gal.	.08
Oil and grease	.02
General repairs	.035
Total running expenses per mile	<u>\$.264</u>

FIXED CHARGES PER 275 DAY YEAR

Depreciation, based upon 25% per year on \$4636.50	\$1157.13
Interest on money invested at 6% (figured on equipment less cost of tires)	392.19
Driver at \$7.00 a day	1925.00
License	27.00
Insurance, fire, theft and liability, based on \$1 a hundred on 90% of the value of the new truck for fire and theft, and a flat rate of \$33.75 for liability	101.75
Total fixed charges for 275 day year	<u>\$3603.07</u>
Total fixed charges per day	12.92

TOTAL EXPENSES

	30 miles	40 miles	50 miles	60 miles
Uniform variable charges per mile \$.247	\$7.92	\$10.56	\$13.20	\$15.84
Fixed charges per day	12.92	12.92	12.92	12.92
Total charges per day	20.84	23.48	26.12	28.76
Total cost per mile loaded one way only	.694	.587	.522	.479
Total cost per 1000 feet per mile with a 4000 foot load	.173	.146	.130	.119

The above costs will be found to be approximately correct for average operations. They will vary somewhat with the road conditions, loads, grades, and the efficiency of the driver. These variations, however, will be slight. They will not amount to more than one cent per thousand feet per mile of haul. The investment pays the owner six per cent and provides renewals for all time. The interest charge is based on the total cost of the equipment less the cost of the tires. The tire cost is deducted in figuring the interest charges because this item is covered under running expenses. The resale value of the truck at the end of four years is not deducted from the interest charge, because this sum is tied up for that length of time. Renewal for the equipment is taken care of by the creation of a sinking fund based on an average life of four years. Theoretically, on a 5-ton truck, \$1157.13 is put aside each year for four years at the expiration of which time the aggregate of these savings together with the resale value of \$1900, automatically provides for the purchase of new equipment.^[7]

[7] Timberman. Feb., 1918. Page 60.

A fifty-mile haul may be used as an illustration for figuring the total running expense of the 5-ton truck. This means that the truck makes trips enough to total fifty miles for the day's run. The cost per mile, including gasoline, oil and repairs is 26.4 cents. It will, therefore, cost \$13.20 for the fifty miles. To this amount must be added \$12.92, daily overhead charge, making a total of \$26.12 for fifty miles traveled or 52.2 cents a mile. With an average load of four thousand feet the cost will be 13.0 cents per mile per thousand feet. A glance at the table will show that the greater the mileage and the larger the load, the less will be the overhead expense and consequently the

cost per mile per thousand feet. To these items must be added the cost and maintenance of the road if one has to be built.

ROAD CONSTRUCTION

The question of the kind of road for hauling logs with the motor truck is a very important one. It is impossible to move a fifteen-ton load day in and day out unless there are good roads, and no motor truck operation of reasonably large proportions can be successfully maintained without a road that is well constructed and which will not give way during any kind of weather, under the loads that are carried. One cannot successfully and continuously operate on dirt or even gravel roads as they are good only when dry. Good roads are as important to the motor truck operator as the railroad is to the transportation of logs by rail.

The big handicap in motor truck logging in the past has been poor roads. The same man who will survey, grade, carefully lay and ballast the steel for a logging railroad will many times put a truck and trailer on a poor dirt road and expect the truck to haul economically and satisfactorily. A motor truck will haul over some mighty poor apologies for roads but it does not pay. A good road is an excellent investment. It makes larger loads and more trips a day possible, will save on tires and repairs, and will require less gasoline to the mile; the efficiency and output will be increased and the time and operating costs will be decreased.



Sub-grade for motor truck logging road.

There have been some very successful operators who have secured a small body of timber at a low price on a public road who made the motor truck pay without building a road. This method of logging in a small way will continue to be carried on by small operators who will haul only during three seasons of the year or even less. However, the big future for the motor truck for logging is in the larger tracts of timber where it would not pay to put in a railroad but where a good type of motor truck road can be built cheaply and loads as large as the truck can handle be carried with no road restrictions as to the weight.

In general four types of roads are used by loggers: (1) the cross-plank road, (2) the fore and aft pole road, (3) the fore and aft plank road, and (4) the cement road. The puncheon road is a modification of the fore and aft plank road and will be taken up with the latter. The methods and cost of construction, the advantages and the disadvantages of these various types of roads follow in detail.

Sub-Grade: The sub-grade is put in the same way for each type of road. The average width of the truck is seven feet and six inches, calling for a road about eight and a half feet wide, so that the sub-grade should be twelve feet in width. An illustration of the amount of grading necessary is shown on [page 25](#). Too much care cannot be taken in the matter of ditches for draining. In a rainy climate, the water should be carried away from the hill side of the grade every fifty feet.

Cross-Plank Road: The cross-plank road is constructed by laying cull ties on hewn poles lengthwise of the road. Three rows, four feet apart are used and second grade ten foot plank, six

[25]

[26]

inches thick and of random widths, are securely nailed to the ties. Great care must be taken to have the ties laid fairly smooth if the road is to be even. Plank less than six inches in thickness should not be used as the thinner ones very soon crack and go to piece under the excessive jar and vibration.

This is a very expensive road to build as it wastes material. Six thousand feet of lumber is necessary for every hundred foot station, at a cost of \$222 a station for the material alone, without considering the cost of laying it. The maintenance cost also is very heavy because the nails pull out as a result of the vibration caused by the truck. This type of road is used only over short stretches, such as swampy ground in connection with the dirt road, and on steep grades and sharp turns in connection with the pole or plank road. [27]

The Esary Logging Company at Camano Island, Washington, put in a cross-plank road for a short distance on a sharp curve and a steep grade, to see how it would affect the traction. It was found that cross planking was not necessary on curves where the grade is ten per cent or less when coming down with a load, providing trailer brakes are used. In the future the company will not use this type of road unless grades above this maximum are encountered. It is impossible to lay a cross-plank road smoothly because the stringers settle and make the road bumpy. The resulting jar on the equipment and the fact that these stretches have to be taken at a much reduced speed, furnish ample reason to condemn its use.

The only real use for a cross-plank road is to secure better traction on grades exceeding ten or twelve per cent, and then it should be laid with a space of about one inch between the planks. Even in such cases it would be better to use some other method for securing traction, such as sanding the track or winding the drive wheels with a light cable. The waste of material and the excessive vibration limit the use of this type of road.

Fore and Aft Pole Road. In the fore and aft pole road, poles from twelve to fourteen inches in diameter are hewn on one or more faces and laid longitudinally with the road, with one or more logs for each wheel track. This type of road is commonly used by motor truck loggers and is one that lends itself readily to their use. It is the most practical road that can be built unless there is a small saw-mill handy to saw planks for the fore and aft plank road. The smaller material growing along the right of way is used at an expense of only what it costs to fell it, hew it and put the poles in place. Hemlock poles may be used to advantage.

Some operators use the single large pole placed on cross-ties eight or ten feet apart and use lighter eight-inch poles placed on the outside for a guard rail to keep the truck from leaving the track. The main pole is laid in a ditch about eight inches deep, leaving it half buried. This helps to keep the poles from spreading and increases their firmness and strength. The pole is notched into the cross-ties, which are made of logs not less than eight inches in diameter, and is securely nailed or bolted to prevent it from rolling. The outside guard rail is laid on the surface of the ground close to the main track and is securely braced from the outside by means of posts sunk into the ground or it may be spiked to the main pole or to the ties. When running with the trailer on this narrow type of road, the guard rail is very necessary. [28]

After the poles have been laid, the sub-grade should be ditched in the center deep enough to carry away the water that falls in the middle of the road. The success of the road depends to a large extent upon good drainage.

The Meicklejohn and Brown Logging Company near Monroe, Washington, operate over a pole road with three poles for each wheel. The poles are from ten to twelve inches in diameter at the small end and are hewn to a six inch face, giving an eighteen inch bearing surface for each wheel. (See [illustration](#) on page 29.) The minimum sized pole that should be used for roads of this character is one eight inches in diameter at the small end. The road is constructed the same way as the single pole road and the poles are laid on cross ties twelve inches in diameter placed from eight to ten feet apart. Where the road is off the ground as when crossing over a small depression, these sleepers must not be over five feet apart. The guard rails at this operation are held in place by means of a wooden brace nailed from each end of the rail to a near-by stump. The ends of the poles used for the track are adzed so that they match evenly. By breaking the joints and hewing them the road presents a level surface with no bumps.

In planning the curves, it is necessary to make the tracks somewhat wider than on straight stretches in order to keep the trailer from running off. The track should be three feet wide on sharp curves and provided with a stout guard rail if there is any danger of the truck leaving the track. The curves are banked on the opposite side from that used on railroad curves. That is, the inner rail is raised about three inches. This is to throw the load to the outside away from the inner guard rail, making it easier to make the turn without the rear wheels binding. In this way a 35 degree curve may be negotiated with forty or fifty foot logs. As the curves have to be passed at a much reduced speed, there is little danger of the logs rolling off due to the raised inner rail.

The grading for a road of this construction is usually light. The grades should, if possible, be kept below five per cent. A truck will operate better on a ten per cent grade in dry weather than on a five per cent one in wet weather. On a road of this type, grades up to ten per cent can be operated over unless there is snow. When the grades are above this and the weather is wet, traction still may be secured by sanding the road or by tacking an old half inch steel cable to the road in the form of a figure "s". If this is sanded in addition, the truck may safely be taken up a steeper grade than it would be safe to bring it down without sanding. [29]



The most common type of motor truck logging road—
a fore-and-aft pole road.

The pole road could be greatly improved by hewing the faces of the poles where they come together side by side so that an even fit is made. The details of this improved form of construction are shown in [figure 1](#), page 30.

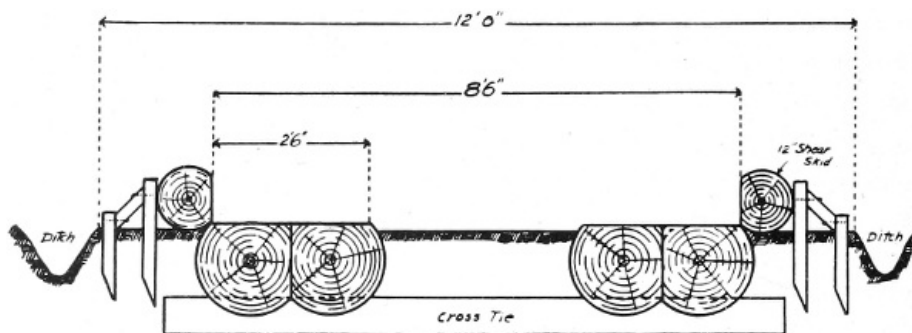

[30]

Figure 1. Cross section of pole road. Scale—1 inch equals 2 feet.

At the present time this is not done and there are one or more ruts in the surface of the road due to the rounding off of the poles where they are placed side by side. The front wheels of the truck are constantly dropping into these ruts, tending to spread the track apart and making it harder for the driver to steer. The tires also suffer from uneven wear. With this deep groove in the track, a certain amount of the traction of the rear wheels is also lost. Hence a much better road would be one with the inner faces of the poles hewn so that a tight fit is secured.

This road can be built of two large poles or three smaller ones to give a flat track two and a half feet wide for each wheel. Laid nearly flush with the ground the guard rail can be eliminated with this width of track, except on sharp curves and other locations where there would be danger if the truck left the track. On such a road the traction will also be increased, better time can be made, the truck will be easier to steer and hence safer to operate, and there will be less wear on the tires. Such a road can be very easily and cheaply built by bringing in a portable sawmill and slabbing the material on two sides to the desired face.

The life of a good pole road is from three to four years if kept in good repair. The maintenance cost is very light if the road is properly constructed in the first place, consisting chiefly in removing a pole here and there that shows signs of too much wear, and in bracing guard rails where they weaken. The use of two or three hewn poles laid lengthwise for each wheel without cross-ties does not pay as the poles soon get out of place even when trenched, and the loss of traction due to the irregularities and of time and money in the upkeep of such a road more than justifies putting in a good road in the first place.

The cost of a fore and aft pole road varies with the accessibility of the material and the cost of the labor. In the past they have been built for as low as \$2000 a mile, but with the present prices costs will range from \$5000 to \$7000 a mile. One company within the year contracted the grading and construction of the road for \$70 a hundred foot station, not including the cost of clearing and chunking out the right of way. The total cost was about \$125 a station or \$6600 a mile.

[31]

Some of the advantages of the pole road are that it is tough and strong and does not crack, split

or break easily so that if it is properly put in it lasts and requires but little maintenance. The material for its construction is found along the right of way and being small in diameter is less expensive than other road materials.

Fore and Aft Plank Roads. This type of road is constructed by placing cross-ties from eight to ten feet apart, center to center, upon which are placed lengthwise for each wheel, two or three sawed timbers not less than six inches in thickness and from twelve to fifteen inches in width. A good road of this type will deliver 150 million feet of logs at a conservative estimate.

The grading is usually light and in many places entirely unnecessary. Second-grade six by eight ties with the eight inch face placed down, or hewn poles are laid about eight feet apart. Where the road bed is soft, the ties are placed closer and in some places as near as two and a half feet apart. Over very swampy ground, the road known as the fore and aft puncheon road is used. It consists simply of cedar puncheon placed crosswise of the road with the usual planking nailed securely to it. The plank used should never be less than six inches in thickness in the main road as it has been proved that four inch plank very soon give way under the heavy loads. On the spur lines it is practicable to use four inch plank because the road is used only a short time.

The total width of the road is eight feet and the plank are laid on top of the ground, but if they are sunk nearly to the level of the ground the road is made considerably more firm and enduring, and of course is safer. The ends are adzed smooth to present an even surface, drift-bolted to the ties, and all joints broken.

The plank in the track are kept together by means of a three by four inch timber driven tightly between the tracks on top of the cross-ties at each joint, and a block nailed to the outside of the tie at each joint with a wedge-shaped piece of wood driven between it and the plank. (See [illustration](#) on page 33.) This wedge is driven in from time to time as occasion may demand. If, in addition to this construction, dirt or gravel is filled in the center to the level of the track, the road is made very solid.

[32]



Fore-and-aft plank road with wedges on cross ties to facilitate the re-aligning of the planks.

With a good road of this type and a bearing surface of thirty inches, the trouble and expense of a guard rail may be eliminated. When a light truck is used for a small body of timber such a wide and heavily constructed road is not practical. In this case, a four inch plank with a fifteen inch surface and an eight inch pole for a guard rail would be used. Here again the track must be made wider on the sharp curves, often as wide as three and a half feet. Usually, the inner rail is made wider than the outer one. On very sharp curves the track may have to be planked solid to keep the trailer from running off. By sawing out chips from one-half to one inch wide two-thirds of the way through the plank, and about six feet apart on the inner side, a long plank may be bent around quite a sharp curve. The ties, of course, should be placed so as to allow the cut sections of the plank to rest squarely on them. This does away with the short pieces and so strengthens the track.

The company logging at Camano Island, Washington, operates over a road of this type, an [illustration](#) of which is shown on page 38. The difficulties encountered in the construction of this particular road were very considerable as a cut through very hard shale, in some places as much as seven feet, was necessary. The maintenance on this road is heavier than is usual. Two men are employed to work on it continually. The work consists of blocking up the loose ties and plank, making any necessary repairs and keeping sand and gravel on the steep grades. The cost of this work is good insurance as it keeps the road in the best of condition at all times and saves on other operating expenses.

[33]



Detailed view of fore-and-aft plank road,
showing method of wedging.

Cost. The first cost of a road of this type is high but it more than pays in the long run if a large body of timber is to be hauled over it. The timber used in its construction amounts to about 160 thousand feet per mile. Second grade material can be used at a cost of approximately \$5,500 a mile for the plank. The total cost per mile varies from \$6,000 to \$8,000. The plank road at Camano Island cost \$20,000 for two and three-quarter miles, which includes the cost of the plank, the grading and labor of putting the plank in place. This is at the rate of about \$7,275 a mile, or approximately \$138 a hundred foot station. The overhead charge for the road at this operation is \$.75 a thousand feet of timber hauled over it. Plank roads of lighter construction have been built for \$4,000 a mile. The length of life is about the same as that of a pole road, three to four years. [34]

The fore and aft plank road is one of the best roads that can be put in where the timber is of sufficient quantity to justify the expense. The big advantage is the speed that can be made and the saving in the equipment. Such a road is very free from bumps and the jar and vibration on the truck is no greater than on a city pavement. The depreciation on a truck depends to a great extent upon the road operated over. With the above type, depreciation on the truck will not be less than five years. In addition, tire mileage will be double that obtained over a pole road, and the gasoline and repair expense will be very materially cut. Owing to the very small vibration, a load of logs can be brought to the landing as fast as it is safe to let the truck glide on a down grade. Speeds as high as 20 miles an hour can easily be taken without excessive vibration. The traction is greater on this type of road than it is on the pole road, due to the greater bearing surface. Traction on grades up to 12% is easily secured by sanding the plank.

Concrete Roads. Concrete has been suggested as an ideal road material. However, up to the present time, loggers have not been very enthusiastic about this type of road on account of the cost of construction, which is somewhat more expensive than the other types of roads, and on account of the permanence of the finished road which is beyond that needed. To the writer's knowledge, there is no company operating in the Northwest over a concrete road of their own building. In the future such roads may be used to a limited extent on the main haul by companies which have operations extending over at least a five year period. The spur roads will probably always be of some other material.

In building such roads two tracks of concrete, one for each wheel are provided. The sub-grade should be well ditched in the center with cross ditches every fifty feet, as is done with the pole road. It has been suggested that the ditches holding the track be six inches deep and twenty-six inches wide. They are filled to the top with concrete and built with a lip four inches high and four inches wide along the outside on top of the main surface to serve as a guard rail. No forms are necessary except for the guard lip. [35]

A word of caution here may not be amiss. Concrete roads of this nature must be regarded as only experimental, for no specific data are available for determining the proper section of concrete to be used for carrying heavy loads on so narrow a bearing surface. It is evident that the carrying capacity of such strips of concrete would be greatly affected by the character of the sub-base. It will therefore be impossible to specify a standard that can be used under all conditions.

The use of the concrete guard rail is one of the disadvantages of this road. The edges of the rail cannot be made rounding except by special forms and the rubbing of the tires against this rough surface would greatly reduce the tire mileage. In addition, the rail is so exposed to weather and hard wear that it cannot be relied upon to serve effectively for any great length of time. The

placing of forms is also a considerable item of expense in building such a road. A method which would eliminate such an expense and at the same time provide a more practical rail would be an advantage.

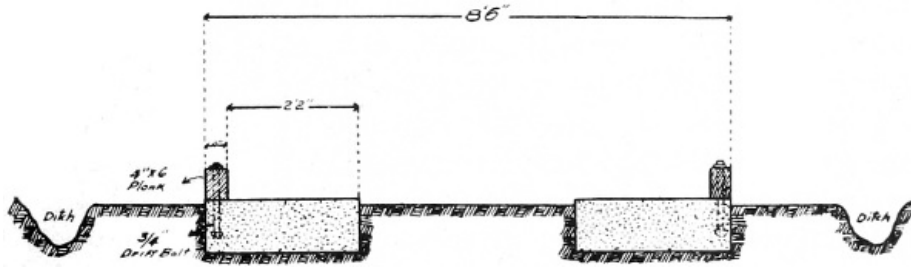

Figure 2. Cross section of concrete road. Scale—1 inch equals 2 feet.

It has already been said that guard rails are unnecessary with a thirty inch track except on sharp curves and otherwise dangerous places. However, where rails are necessary the wooden rail fastened by bolts embedded in the concrete as illustrated above, is quite effective and readily installed. This consists of a four by six inch plank placed on edge and drift-bolted to the concrete every three to five feet by a three-quarter inch bolt. These bolts are placed in the concrete when it is poured and should be embedded six inches. This will provide a rail less expensive to build than a concrete rail and one which will last longer and save on tires. Replacements are easily made by removing the nuts and placing a new plank in place of the old. With a guard rail of this type, there is left a twenty-six inch track for the wheels to run in.

[36]

Experiments by W. D. Pence (Journ. West. Soc. Eng. Vol. VI, 1901, Page 549) on 1 : 2 : 4 concrete give an average value of 0.0000055 inches per degree Fahrenheit for the coefficient of expansion. The richer the concrete, the greater the change in dimension. Due to the expansion, in laying the concrete the track must be broken every twenty-five or thirty feet by placing a half-inch board in the ditch when the concrete is being filled in. Later this board is removed and the joint filled with asphalt so that the concrete may expand without danger of cracking the road.

Cost. The best mix to use in building this road is what is known as the 1 : 2½ : 5. For one cubic yard of concrete, the following amounts of materials will be used for the above mix: 1.21 barrels of cement, 0.46 cubic yards of sand, and 0.92 cubic yards of stone. At the present prices, the cost for the materials for this road is about twenty cents a cubic foot or about \$4,400 a mile. The total cost of the road including the necessary grading, ditching and labor, will be from \$7,000 to \$9,000 per mile.

One of the big advantages of the concrete road is the large gain in traction secured when operating on steep grades. A motor truck will haul up a twelve per cent and down a fifteen per cent grade in wet weather on concrete due to the roughened surface on which the tires do not easily slip. This, of course, would be dangerous to attempt on the other types of roads. Another advantage is the small item of upkeep necessary. A road well laid in the first place should need no repair except to replace worn guard rails as they show signs of weakening. The concrete road, however, will not be generally used except on the mainline by the larger concerns, or for short distances on steep grades where greater traction is desired.

BRIDGES

In most cases the construction of bridges is unnecessary on account of the steep grades the trucks can take and because they can negotiate sharp curves, which make it easier to avoid expensive bridge work. Where they are absolutely necessary a serviceable bridge is made of cribwork.

[37]

The Esary Logging Company of Camano Island, Washington, operates over a crib bridge 175 feet long and 15 feet high. The sub-structure of this bridge is made of logs laid alternately crosswise in tiers. Six by twelve inch plank are laid diagonally on the cribbing and four by twelve inch plank are placed on crosswise to the road on top. This makes a bumpy surface. A better one could be made with cross-ties placed on the cribbing with fore and aft planking on top. A guard rail is placed on all bridges.

Short bridges up to eighty or ninety feet in length are constructed by the use of two large logs hewn flat on the upper surface. The logs should be at least thirty-six inches in diameter and perfectly sound. They are placed at the proper gauge and the regular road on cross-ties constructed on top. On such short stretches this type of bridge has been operated over without supports. It is not used, however, for long stretches. The long bridges are, of course, constructed of bents or piling but are very seldom used in connection with motor truck transportation on account of the expensive construction and because they are usually unnecessary.

TURNING DEVICES AND TURNOUTS

When the truck and trailer reach the place where they are to be loaded, some method must be used to turn them around. Various means are used to accomplish this. One is the motor truck turn-table. The turn-table should be slightly longer than the length of the truck and trailer combined. It is constructed of heavy plank and timbers so that each track is about 16 inches wide and tapers in thickness from about 14 inches at the center to 4 inches at the ends. The two tracks are held together at the center and each end by heavy timbers. A heavy timber is sunk to the level of the road and at the center two circular saws are laid. A king bolt through the center brace of the turn-table and through the two saws into the sunken timber provides a pivot upon which the table turns. When properly balanced and with a little oil between the surfaces of the saws, the turn-table can be operated by hand with very little effort. It is usually placed at the end of the road. A turn-table can be loaded on the truck and trailer when it is desired to move it, so that as the road is extended into the timber, a means of turning the truck can be obtained close to the point where the logs are to be loaded. This device can be built at a cost of from \$75 to \$125 and is very serviceable. The main objection to its use is that the setting has to be just right to make it work satisfactorily and it is sometimes difficult to get a spot that is level enough. It is always a difficult problem and a different one for each set-up. [38]

The use of the "back around" is more common with truck loggers at present because it is easier to build. The back-around is simply a pocket or short spur along the road above the landing ground which is planked solid. The truck and trailer are backed into this far enough so that the truck can pull ahead in the opposite direction. This method of turning the truck requires only a little extra clearing and grading and is less expensive and more easily constructed than a turn-table.



Turn out on fore-and-aft plank road.

When two or more truck units are to be used on a single track, a careful calculation must be made to determine the best passing places. The location of these points may determine the success of the operation. They should be placed so that the truck returning empty can reach the turnout before the loaded one comes along in order that the loaded one may not be held up. At the same time, the turnout should not be so far away from the loading ground that the loading crew will be idle for any length of time while waiting for an empty truck. It is better to have an extra turnout, even if seldom used, than conditions that would hinder efficient operation or might even result in a collision which would tie up the logging for several days. [39]

A few loggers build a turnout of the same material as the main road for a short distance to the side. An illustration of this type of turnout is shown [above](#). Most of them, however, simply clear off a right of way and put in a gravel bottom for the road as the waiting truck at this point is empty and will not ordinarily sink into the ground and get stalled. A few heavy planks laid fore and aft in the form of a track are sometimes used. The construction of passing places is very simple—the only important thing to be taken into consideration is the proper point at which the trucks should pass in order to keep the operation going at maximum efficiency.

TELEPHONES

In connection with the passing places, the installation of a telephone line is an important but

often neglected item. With two or more transportation units, a telephone line is a handy if not well nigh indispensable accessory. It is a great advantage to have such a system with stations at each end of the road and also at the passing places, as unavoidable delays will frequently allow a waiting truck to move on to another passing place, thus saving time. To avoid accidents, the driver at the passing place should call the loader at the spar tree to see if the road is clear before coming any farther.

Very often something breaks on the yarding or loading donkey. With the telephone, perhaps a half day of shutdown may be saved by calling the main camp for the repair parts and having them brought up by the next truck. The saving due to avoided accidents and the saving of time more than pays for the initial expense of installation. The telephone line should not be neglected at the larger operations.

INCLINES

In rough country the use of the incline has been a great help and has proved to be entirely practical and quite economical. Grades as high as sixty or even seventy per cent can be safely taken with an incline if the proper measures are taken to prevent accidents. [40]

A typical incline is successfully operated by the Meickeljohn, Brown Logging Company near Monroe, Washington. It is fifteen hundred feet long and the steepest grade is twenty-eight per cent. An 11-in. × 14-in. roader donkey located at the top of the incline snubs the loads down and hauls up the empty trucks. A one and one-eighth inch wire cable is thrown around the logs and made fast by means of a clevis. This holds the truck and prevents the logs from slipping forward and injuring the driver. On all inclines, the line should be choked around the logs rather than simply attached to the truck to prevent them from slipping ahead.

The snubbing device consists of an ordinary donkey engine fitted with a hand brake of extra large size and special air valves so that air is sucked into the cylinders and let out of the exhaust when the engine is being pulled backwards by the weight of the load. The load is controlled by the amount of air let out of the valves. The braking action is very positive and the load can be stopped in a few revolutions of the crank shaft.

The average time to lower the load down the incline is three and a half minutes. At the bottom of the incline, the cable is released and the truck goes on its way. The cable is attached to the waiting truck by means of a ring fastened to the frame and the donkey pulls the empty truck to the top. The time taken to raise the trucks is three minutes.

On grades too steep to operate a truck safely with the ordinary brakes and yet not steep enough to warrant the expense of the donkey snubber, the difficulty is overcome by means of a friction snubber. This consists simply of a cable which is hooked to the truck and extends through a system of three or four pulleys and thence on down the track. The friction of this line dragging on the ground and passing through the pulleys is enough to hold the load so that the truck engine must exert power to pull the load down the grade. The line is made long enough so that as the load reaches the bottom of the grade, the free end of the cable has been pulled up to the system of pulleys and is ready to be attached to the next load. This system is efficient for small grades, is inexpensive to install, and requires no further attention.

By the use of the incline with the donkey engine snubber, very heavy grades can be taken. The construction of the incline is the same as the rest of the road and is only slightly more expensive to build because of the inconvenience of laying it on such a steep slope. The use of the incline will not slow up the operation to any great extent as from fifty to seventy thousand feet of logs (which is about the average yarding and loading capacity of one motor-truck side), can be taken over it in a day. This method of hauling down steep grades is used in several operations and has been found to be entirely successful. [41]

YARDING

A variety of methods are used by motor truck loggers to get the logs to the landing to be loaded. The larger operations invariably use the high-lead method of yarding as the logs come in quicker and with fewer hang-ups. In a few places the old ground method of yarding with a bull block is still used. The horse team and skid road is used in a small timber where poles and piling are being marketed. The latter is a slow method but will keep one truck busy and is still used in some places where small stands are located along the highway or in other readily accessible places.

LOADING AND UNLOADING

The loading of a motor truck is very much the same proposition as the loading of a flat-car. The

principal difficulties that trucks have had to contend with have been poor roads and inefficient methods of loading. In loading, the main trouble has been in regulating the yarding so that a supply of logs is always on hand. The use of the gin pole and crotch line operated by the straw drum of the yarding donkey ties up the yarding until the truck is loaded. This is being overcome by using a separate engine with the high lead for yarding and doing the logging independently of the yarding as is done in the case of railroad logging. In this way the yarder can keep ahead of the loading engine and there will be no delay at the landing.

Most of the larger companies load with the Duplex loader and use tongs. This is a safer way to load than with the crotch line as the logs can be more easily controlled. The danger of dropping a log through the truck or of knocking off the top of the truck or the driver's seat is greatly lessened.

In pole and piling timber where a skid road and horses are used, loading is done by hand or with a team. A landing is built of cribwork and the logs are simply rolled on the truck with peavies or cant hooks, or a parbuckle system with skids and horses is used. This works fairly well for small operations in small timber.

[42]



Loading a motor truck and trailer through the use of a boom.

The latest development in loading is the boom. An illustration of this method is shown [above](#). The boom itself is a fifty to sixty foot pole about eighteen inches in diameter at the base and is attached to the spar tree by means of a metal strap with two lugs which are fitted into holes bored in the spar to keep the strap from slipping. The base of the boom is fitted with a metal joint which moves freely on an upright pin set in the metal strap. (See A, [above](#).) The whole rig is set high enough on the tree so that it may be swung in a semi-circle and clear the loaded truck by several feet. A light line (B) from the haulback drum of the donkey passes through a block attached low on the spar tree and thence to another block on a stump to the right of the landing. From here it passes through a third block at the end of the boom and back to the stump again. This secures the needed pulling power from the haulback drum.

[43]

The lifting line from the mainline drum passes through a block half way up the tree and thence through a free swinging block (C) and back to the tree again. On the second block is a ring to which two one inch lines (D) are attached. These lines pass through the boom stick on rollers (E) about fifteen feet apart. On the ends of these lines hooks are attached. These two lines should be so arranged that the hooks remain parallel to the ground. Two three-quarters inch cables (F) with an eye splice in each end are attached to the hooks. These lines, or chokers, are then wrapped around the log and it is lifted clear of the ground by means of the block hold in the main line.

The haulback line (B) from the donkey is slacked and the boom travels over to the truck by means of a line (G) attached from the boom to a dummy log running on a special guy line. A log two feet in diameter and sixteen feet long is wrapped at each end with a cable and fastened to a pulley. The two pulleys and attached dummy log travel up and down the guy line as the boom moves. A line is attached to the boom and runs through a pulley attached to the dummy log and extends back to the boom again. This pulls the boom over above the truck as the dummy log travels down the guy line. The logs are held parallel to the ground above the truck and the truck is run under the boom to the location designated by the head loader. With this system the logs will not drop suddenly on the trucks as the log will fall off while being carried over to the truck if there is any danger of its falling at all. After the log is placed, the boom is pulled back to the landing by the haulback line. This system has worked with success in a number of motor truck operations and is a safer method than loading with tongs because the logs cannot accidentally drop and injure the truck. However, the loading situation should be studied carefully. The most efficient loading

device for the particular needs of the operation may be installed as any loss of time in loading seriously affects the output of the operation.

Most of the truck loggers unload their logs into water; either into a lake, a river that can be driven, or into tide-water. A few, however, unload directly into the log pond at the mill or at the log yard in case the mill has no log pond.

The road is usually planked solid at the unloading ground. A great help in unloading is a dock from six to twelve inches higher on one side than on the other so the logs will roll off the truck easily. The brow-skid should be close to the log bunks and just a little lower than these when the truck is tilted. When unloading into shallow water, such as a small river, six or eight skids a foot and a half in diameter are placed so that they slope from the brow-skid to the water at an angle of forty-five degrees. An illustration of this method of unloading is shown below. The skids are so placed that the unloading ground will not be undermined.

[44]



Unloading truck and trailer through the use of an incline, showing brow-skids and roll-way.

When the truck comes to a stop on the incline, the chock blocks are released from the opposite side and the logs roll off of their own accord. In some instances a gill-poke has been used in connection with the unloading incline, the logs being sheared off as the truck moves ahead. Usually the logs roll off readily without the use of the gill-poke and if a load does stick it can be loosened with a cant-hook, so that the gill-poke really is unnecessary.

Unloading on public wharves or roads where no permanent incline can be used is accomplished by placing a portable wedge-shaped timber in front of the outside truck and trailer wheels and driving upon it.

[45]

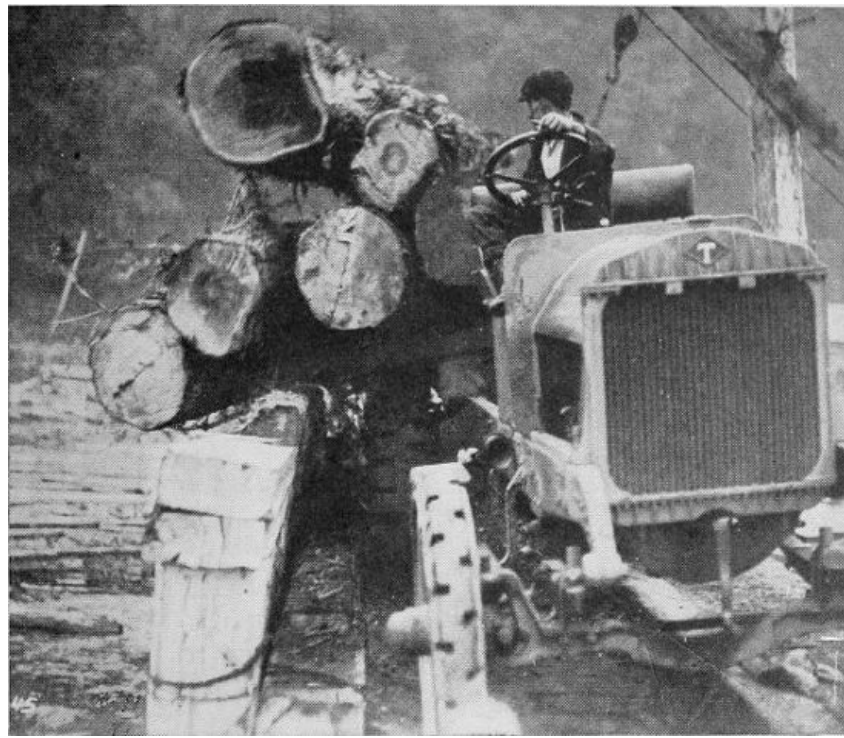

Parbuckling a load of logs from the truck and trailer.

In the most efficient way of unloading the usual brow-skid is placed a few inches below the log bunk and the logs are parbuckled from the truck and trailer, an illustration of which is shown above. The trucks are run on an incline so that one side is raised about four inches. A crotch-line consisting of two half-inch cables is attached to the brow-skid and passed under the logs to a ring fastened to an inch cable. The larger cable passes thru a block located on a gin pole. A light yarding or a land clearing donkey furnishes the power to parbuckle the logs into the water. By this method the logs are lifted from the truck as they are rolled into the water with little danger of the top log dropping on the log bunk as is often the case when other methods are used, resulting in expensive repairs for broken springs or bearings.

TIME STUDIES

Time is a very important item in loading and unloading. Usually the most time is consumed in loading, for which reason any improvement that will reduce the time taken to load will greatly increase the efficiency of the operation. With the proper unloading devices, the truck may be unloaded in the time required to knock down the chock blocks. [46]

The following table is a record kept for one day of the actual time taken by a truck at each step in the hauling of logs at one operation. However, it is possible to give only arbitrary figures to fit the particular operation of which they are taken. No average figures can be given that fit all conditions.

	DONKEY ENGINE				DUMP AT MILL				Scale
	Arrive	Time Loading	Leave	Time Down	Arrive	Un-loading	Leave	Time Up	
A.M.									
7:15	10 Min.	7:25	20 Min.	7:45	25 Min.	8:10	20 Min.	2592	
8:30	5 Min.	8:35	27 Min.	8:57	13 Min.	9:10	20 Min.	2092	
9:30	12 Min.	9:42	21 Min.	10:03	7 Min.	10:10	20 Min.	1908	
10:30	12 Min.	10:42	33 Min.	11:15	30 Min.	11:45	20 Min.	3074	
P.M.									
12:05	10 Min.	12:15	35 Min.	12:50	17 Min.	1:07	20 Min.	2542	
1:27	15 Min.	1:42	18 Min.	2:00	27 Min.	2:27	20 Min.	1828	
2:47	8 Min.	2:55	21 Min.	3:16	8 Min.	3:24	20 Min.	1689	
3:44	11 Min.	3:55	23 Min.	4:18	9 Min.	4:27	20 Min.	2407	
4:47	14 Min.	5:01	26 Min.	5:27	12 Min.	5:39	20 Min.	2558	
								Total	20690

Length of haul 5.9 miles round trip.

Amount of gasoline, 15 gallons.

The above figures were taken several years ago when the facilities for unloading were slower than the present day methods, which accounts for the excessive length of time taken to unload.[8]

[8] The writer is indebted to Mr. George Gunn, Jr., for these figures.

The unloading of a truck is a time when a little care taken will save considerable expense for repairs. Such a method as the parbuckling system should be used by companies with sufficient stumpage to warrant the expense of the extra donkey, to prevent the top logs from dropping to the log bunks, thereby saving the cost of repairing broken springs and bearings.

CONCLUSION

At present, the possibilities for the use of the motor truck for logging are just beginning to be realized. What effect their use will have upon the future methods of logging remains to be seen. It is certain, however, that the advent of motor truck transportation will have a marked effect upon the science of forestry and will bring about a closer utilization of our timber resources.

The motor truck and the portable band mill seem likely to furnish a combination which will do away with the old wasteful circular mill because it supplies the cheapness and efficiency of railroad transportation and is applicable to small and scattered tracts and to stands of low-grade lumber. The fact that the portable band mill may be moved for a cut of a million feet assures adaptability. This is not only an industrial advance but also a silvicultural advance in that it affords the possibility of cuttings at frequent intervals without greatly adding to the cost. [47]

A closer utilization of our present stands of timber may be practiced by the use of the motor truck. In the northwest, only the larger material is taken from the forest, leaving a large amount of good timber on the ground in the form of poles and piling and chunks too short to be made into saw lumber but from which high grade ties can be made. The truck, in connection with a band mill, will furnish a means of utilizing this present waste at a profit to the operator.

The motor truck will be a valuable aid in the working out of a sound national forest policy for the proper use of our timber resources so that the timber will be utilized to the greatest possible extent and at the same time methods taken to provide for the perpetuation of the forest for future generations. This suggests a way of opening the timber for the market on some of our national forests. Most of the government owned forests are situated in more or less rugged country back from the regular routes of travel. The timber on a great many of these forests is over-mature and should be cut but at this time it is inaccessible. The problem confronting the country is how to make it accessible.

The plan for opening these forests is to build permanent concrete or asphalt roads from the nearest commercial centers thru these tracts taking into consideration the aesthetic value of the location as well as the possibilities of logging the timber from them. The timber, then, is to be taken out, under some silvicultural system and under government supervision, by motor truck operators who build their own roads from the nearest concrete road to the timber to be cut. Under this system of management, the state and federal government pays a part of the expense of building the permanent road and the operator pays a small sum for the use of the road by being taxed additional stumpage.

The system of management has many advantages. In the first place, the mature timber will be logged, the older decadent material coming out first, in small bodies and at the same time care being taken to reproduce a new stand. The total area is divided so that as the timber is logged in rotation a continuous cutting will be assured. Due to the use of the trucks and on account of the timber being cut in rotation, the fire danger will be greatly lessened. In case a fire gets beyond control, the roads thru the forest make an excellent way to bring in men and supplies to fight the fire. In this way, a fire is readily accessible in a few hours where formerly it took perhaps several days to organize the fire fighting party and reach the scene of action. The concrete roads themselves make good fire lines. By means of the good roads, the forest is opened to campers and tourists each of whom pays a small sum as they enter the forest to help pay for the cost of building the roads and to provide funds for more extensive highways. In this way the forest is opened for the timber, the best methods of utilization and forest regeneration are practiced, fire hazard is reduced, and the area is opened as a recreational ground so that the greatest possible value is obtained from the tract. [48]

A great many other uses of the motor truck for logging and scientific forest utilization are being recognized, as example, for transporting pulpwood, veneer stock, cordwood, rosin and turpentine, and other forest products. Suffice it to say that this method of transportation has found a place in the industry and is here to stay. Its value has been recognized beyond doubt and in the future will play an important part in the further development of this country.

BIBLIOGRAPHY

1916. Motor Truck Logging.
The Power Wagon. Sept. 15. Page 34. (Periodical).
1916. The Law of the Public Highway in Washington.
West Coast Lumberman. Sept. 15. Page 23. (Periodical).

1916. Motor Truck Logging Now Making Great Strides on the Pacific Coast.
West Coast Lumberman. Nov. 1. Page 260. (Periodical).
1917. Motor Truck Logging in the Pacific Northwest.
West Coast Lumberman. Mar. 15. Page 70. (Periodical).
1917. Motor Trucks in High Favor Among Lumbermen.
Lumber World Review. Mar. 25. Page 23. (Periodical).
1917. Motor Truck Logging on Camano Island.
West Coast Lumberman. July 1. Page 28. (Periodical).
1917. Motor Truck Logging.
The Commercial Vehicle. Sept. 1. Page 12. (Periodical).
1918. Pole Roads. A. R. Hillard.
West Coast Lumberman. Feb. 1. Page 34. (Periodical).
1918. Operating Cost of Motor Trucks Computed. H. S. Finch.
Timberman. Feb. 1. Page 60. (Periodical).
1918. Winch for Motor Trucks.
American Lumberman. Mar. 2. Page 58. (Periodical).
1918. Motor Truck Roads.
American Lumberman. Mar. 16. Page 38. (Periodical).
1918. The Motor Truck in the Logging Industry. H. H. Warwood.
Timberman. April 1. Page 74. (Periodical).
1918. Road Construction for Motor Trucks. Jay C. Smith.
Timberman. April 1. Page 38. (Periodical).
1918. Adjustable Reach Logging Trailer.
American Lumberman. May 18. Page 63. (Periodical).
1918. Demonstrating Duplex Trucks.
American Lumberman. June 1. Page 63. (Periodical).
1918. Modern Motor Truck Solves Difficult Logging Problems.
West Coast Lumberman. July 1. Page 18D. (Periodical).
1918. Motor Trucks in Winter Logging. A. R. Hilliard.
West Coast Lumberman. Sept. 1. Page 25. (Periodical).
1919. The Effect of Changed Conditions Upon Forestry. W. W. Ashe.
Journal of Forestry. Oct. 1. Page 657. (Periodical).
1919. Puget Sound Logger Tells Congress How to Log With Motor Trucks.
West Coast Lumberman. October. Page 25. (Periodical).
1920. Air Brakes for Trucks.
Timberman. Mar. 1. Page 48g. (Periodical).

[49]

The writer has drawn freely from the material found in the above periodicals and trade journals, but wishes to acknowledge the greater bulk of information in writing this paper received from the various truck salesmen and truck operators who were interviewed personally. Without their assistance, the gathering of this information would have been impossible.

Publications of the Engineering Experiment Station University of Washington

- Bulletin No. 1—** Creosoted Wood Stave Pipe and Its Effect Upon Water for Domestic and Irrigational Uses. 1917.
(Bureau of Industrial Research.) 20 pp. Price, 25 cents.
- Bulletin No. 2—** An Investigation of the Iron Ore Resources of the Northwest. By William Harrison Whittier. 1917.
(Bureau of Industrial Research.) 128 pp. Price, 60 cents.
- Bulletin No. 3—** An Industrial Survey of Seattle. By Curtis C. Aller. 1918.
(Bureau of Industrial Research.) 64 pp. Price, 50 cents.
- Bulletin No. 4—** A Summary of Mining and Metalliferous Mineral Resources in the State of Washington with Bibliography. By Arthur Homer Fischer. 1919.
124 pp. Price, 75 cents.
- Bulletin No. 5—** Electrometallurgical and Electrochemical Industry in the State of Washington. By Charles Denham Grier. 1919.
43 pp. Price, 50 cents.
- Bulletin No. 6—** Ornamental Concrete Lamp Posts. By Carl Edward Magnusson. 1919.
24 pp. Price, 40 cents.
- Bulletin No. 7—** Multiplex Radio Telegraphy and Telephony. 1920. By F. M. Ryan, J. R. Tolmie, R. O. Bach.
Price, 50 cents.
- Bulletin No. 8—** Voltage Wave Analysis with Indicating Instruments. By Leslie Forrest Curtis. 1920.

- 28 pp. Price, 50 cents.
- Bulletin No. 9**— The Coking Industry of the Pacific Northwest. By Joseph Daniels. 1920.
- 36 pp. Price, 60 cents.
- Bulletin No. 10**—An Investigation of Compressed Spruce Pulleys. By George Samuel Wilson. 1920.
- 72 pp. Price, 80 cents.
- Bulletin No. 11**—The Theory of Linear-Sinoidal Oscillations. By Henry Godfrey Cordes. 1920.
- 24 pp. Price, 40 cents.
- Bulletin No. 12**—Motor Truck Logging Methods. By Frederick Malcolm Knapp. 1921.
- 52 pp. Price, 50 cents.

Requests for bulletins should be addressed to the Director, Engineering Experiment Station, University of Washington, Seattle.

Transcriber's Notes:

- All inconsistencies in spelling, lay-out, hyphenation, etcetera from the original document have been kept in this e-book, except when mentioned below. The names *Meickeljohn and Brown* and *Meicklejohn and Brown* and *Hillard* and *Hilliard* are both used, these have not been changed.
- Minor typographical and/or printer's errors have been corrected:
 - page 5: *and the used of* changed to *and the use of*;
 - page 13: *distance, is it, of course* changed to *distance, it is, of course*;
 - page 13: *four year depreciation* changed to *four-year depreciation*;
 - page 16: *twisting the the rubber* changed to *twisting of the rubber*;
 - page 26: *page _* changed to *page 25*;
 - page 39: *plank* changed to *planks*;
 - page 39: *is handy* changed to *is a handy*;
 - page 46, table: *A.M.* moved one row down, similar to *P.M.* further down in the table;
 - Table of Contents:
 - page number *4* changed to *5* (2 changes);
 - *Loading and Hauling* changed to *Loading and Unloading* as in text;
 - *Fires* changed to *Tires* as in text.
- Footnotes have been moved to just below the paragraph or table to which they belong.
- Other issues:
 - Page 33 contained a reference to an illustration on page 40, but this page has no illustration. The author probably intended a reference to the illustration on page 38; the hyperlink has been made to the latter page, and the text changed accordingly.
 - Figures 1 and 2 have not been reproduced to scale, despite the scale given in the captions: the size of the illustrations (and therefore their scale) will depend on browser settings, screen size, etc.
 - Table of Contents: the chapter on Road Contruction has paragraphs dealing with guard rails and costs for various types of the roads described. *Costs* and *Guard Rails* have therefore not been hyperlinked to the text.

*** END OF THE PROJECT GUTENBERG EBOOK MOTOR TRUCK LOGGING METHODS ***

Updated editions will replace the previous one—the old editions will be renamed.

Creating the works from print editions not protected by U.S. copyright law means that no one owns a United States copyright in these works, so the Foundation (and you!) can copy and distribute it in the United States without permission and without paying copyright royalties. Special rules, set forth in the General Terms of Use part of this license, apply to copying and distributing Project Gutenberg™ electronic works to protect the PROJECT GUTENBERG™ concept and trademark. Project Gutenberg is a registered trademark, and may not be used if you charge for an eBook, except by following the terms of the trademark license, including paying royalties for use of the Project Gutenberg trademark. If you do not charge anything for copies of this eBook, complying with the trademark license is very easy. You may use this eBook for nearly any purpose such as creation of derivative works, reports, performances and research. Project Gutenberg eBooks may be modified and printed and given away—you may

do practically ANYTHING in the United States with eBooks not protected by U.S. copyright law. Redistribution is subject to the trademark license, especially commercial redistribution.

START: FULL LICENSE
THE FULL PROJECT GUTENBERG LICENSE
PLEASE READ THIS BEFORE YOU DISTRIBUTE OR USE THIS WORK

To protect the Project Gutenberg™ mission of promoting the free distribution of electronic works, by using or distributing this work (or any other work associated in any way with the phrase “Project Gutenberg”), you agree to comply with all the terms of the Full Project Gutenberg™ License available with this file or online at www.gutenberg.org/license.

Section 1. General Terms of Use and Redistributing Project Gutenberg™ electronic works

1.A. By reading or using any part of this Project Gutenberg™ electronic work, you indicate that you have read, understand, agree to and accept all the terms of this license and intellectual property (trademark/copyright) agreement. If you do not agree to abide by all the terms of this agreement, you must cease using and return or destroy all copies of Project Gutenberg™ electronic works in your possession. If you paid a fee for obtaining a copy of or access to a Project Gutenberg™ electronic work and you do not agree to be bound by the terms of this agreement, you may obtain a refund from the person or entity to whom you paid the fee as set forth in paragraph 1.E.8.

1.B. “Project Gutenberg” is a registered trademark. It may only be used on or associated in any way with an electronic work by people who agree to be bound by the terms of this agreement. There are a few things that you can do with most Project Gutenberg™ electronic works even without complying with the full terms of this agreement. See paragraph 1.C below. There are a lot of things you can do with Project Gutenberg™ electronic works if you follow the terms of this agreement and help preserve free future access to Project Gutenberg™ electronic works. See paragraph 1.E below.

1.C. The Project Gutenberg Literary Archive Foundation (“the Foundation” or PGLAF), owns a compilation copyright in the collection of Project Gutenberg™ electronic works. Nearly all the individual works in the collection are in the public domain in the United States. If an individual work is unprotected by copyright law in the United States and you are located in the United States, we do not claim a right to prevent you from copying, distributing, performing, displaying or creating derivative works based on the work as long as all references to Project Gutenberg are removed. Of course, we hope that you will support the Project Gutenberg™ mission of promoting free access to electronic works by freely sharing Project Gutenberg™ works in compliance with the terms of this agreement for keeping the Project Gutenberg™ name associated with the work. You can easily comply with the terms of this agreement by keeping this work in the same format with its attached full Project Gutenberg™ License when you share it without charge with others.

1.D. The copyright laws of the place where you are located also govern what you can do with this work. Copyright laws in most countries are in a constant state of change. If you are outside the United States, check the laws of your country in addition to the terms of this agreement before downloading, copying, displaying, performing, distributing or creating derivative works based on this work or any other Project Gutenberg™ work. The Foundation makes no representations concerning the copyright status of any work in any country other than the United States.

1.E. Unless you have removed all references to Project Gutenberg:

1.E.1. The following sentence, with active links to, or other immediate access to, the full Project Gutenberg™ License must appear prominently whenever any copy of a Project Gutenberg™ work (any work on which the phrase “Project Gutenberg” appears, or with which the phrase “Project Gutenberg” is associated) is accessed, displayed, performed, viewed, copied or distributed:

This eBook is for the use of anyone anywhere in the United States and most other parts of the world at no cost and with almost no restrictions whatsoever. You may copy it, give it away or re-use it under the terms of the Project Gutenberg License included with this eBook or online at www.gutenberg.org. If you are not located in the United States, you will have to check the laws of the country where you are located before using this eBook.

1.E.2. If an individual Project Gutenberg™ electronic work is derived from texts not protected by U.S. copyright law (does not contain a notice indicating that it is posted with permission of the copyright holder), the work can be copied and distributed to anyone in the United States without paying any fees or charges. If you are redistributing or providing access to a work with the phrase “Project Gutenberg” associated with or appearing on the work, you must comply either with the requirements of paragraphs 1.E.1 through 1.E.7 or obtain permission for the use of the work and the Project Gutenberg™ trademark as set forth in paragraphs 1.E.8 or 1.E.9.

1.E.3. If an individual Project Gutenberg™ electronic work is posted with the permission of the copyright holder, your use and distribution must comply with both paragraphs 1.E.1 through 1.E.7 and any additional terms imposed by the copyright holder. Additional terms will be linked to the Project Gutenberg™ License for all works posted with the permission of the copyright holder found at the beginning of this work.

1.E.4. Do not unlink or detach or remove the full Project Gutenberg™ License terms from this work, or any files containing a part of this work or any other work associated with Project Gutenberg™.

1.E.5. Do not copy, display, perform, distribute or redistribute this electronic work, or any part of this electronic work, without prominently displaying the sentence set forth in paragraph 1.E.1 with active links or immediate access to the full terms of the Project Gutenberg™ License.

1.E.6. You may convert to and distribute this work in any binary, compressed, marked up, nonproprietary or proprietary form, including any word processing or hypertext form. However, if you provide access to or distribute copies of a Project Gutenberg™ work in a format other than “Plain Vanilla ASCII” or other format used in the official version posted on the official Project Gutenberg™ website (www.gutenberg.org), you must, at no additional cost, fee or expense to the user, provide a copy, a means of exporting a copy, or a means of obtaining a copy upon request, of the work in its original “Plain Vanilla ASCII” or other form. Any alternate format must include the full Project Gutenberg™ License as specified in paragraph 1.E.1.

1.E.7. Do not charge a fee for access to, viewing, displaying, performing, copying or distributing any Project Gutenberg™ works unless you comply with paragraph 1.E.8 or 1.E.9.

1.E.8. You may charge a reasonable fee for copies of or providing access to or distributing Project Gutenberg™ electronic works provided that:

- You pay a royalty fee of 20% of the gross profits you derive from the use of Project Gutenberg™ works calculated using the method you already use to calculate your applicable taxes. The fee is owed to the owner of the Project Gutenberg™ trademark, but he has agreed to donate royalties under this paragraph to the Project Gutenberg Literary Archive Foundation. Royalty payments must be paid within 60 days following each date on which you prepare (or are legally required to prepare) your periodic tax returns. Royalty payments should be clearly marked as such and sent to the Project Gutenberg Literary Archive Foundation at the address specified in Section 4, “Information about donations to the Project Gutenberg Literary Archive Foundation.”
- You provide a full refund of any money paid by a user who notifies you in writing (or by e-mail) within 30 days of receipt that s/he does not agree to the terms of the full Project Gutenberg™ License. You must require such a user to return or destroy all copies of the works possessed in a physical medium and discontinue all use of and all access to other copies of Project Gutenberg™ works.
- You provide, in accordance with paragraph 1.F.3, a full refund of any money paid for a work or a replacement copy, if a defect in the electronic work is discovered and reported to you within 90 days of receipt of the work.
- You comply with all other terms of this agreement for free distribution of Project Gutenberg™ works.

1.E.9. If you wish to charge a fee or distribute a Project Gutenberg™ electronic work or group of works on different terms than are set forth in this agreement, you must obtain permission in writing from the Project Gutenberg Literary Archive Foundation, the manager of the Project Gutenberg™ trademark. Contact the Foundation as set forth in Section 3 below.

1.F.

1.F.1. Project Gutenberg volunteers and employees expend considerable effort to identify, do copyright research on, transcribe and proofread works not protected by U.S. copyright law in creating the Project Gutenberg™ collection. Despite these efforts, Project Gutenberg™ electronic works, and the medium on which they may be stored, may contain “Defects,” such as, but not limited to, incomplete, inaccurate or corrupt data, transcription errors, a copyright or other intellectual property infringement, a defective or damaged disk or other medium, a computer virus, or computer codes that damage or cannot be read by your equipment.

1.F.2. LIMITED WARRANTY, DISCLAIMER OF DAMAGES - Except for the “Right of Replacement or Refund” described in paragraph 1.F.3, the Project Gutenberg Literary Archive Foundation, the owner of the Project Gutenberg™ trademark, and any other party distributing a Project Gutenberg™ electronic work under this agreement, disclaim all liability to you for damages, costs and expenses, including legal fees. YOU AGREE THAT YOU HAVE NO REMEDIES FOR NEGLIGENCE, STRICT LIABILITY, BREACH OF WARRANTY OR

BREACH OF CONTRACT EXCEPT THOSE PROVIDED IN PARAGRAPH 1.F.3. YOU AGREE THAT THE FOUNDATION, THE TRADEMARK OWNER, AND ANY DISTRIBUTOR UNDER THIS AGREEMENT WILL NOT BE LIABLE TO YOU FOR ACTUAL, DIRECT, INDIRECT, CONSEQUENTIAL, PUNITIVE OR INCIDENTAL DAMAGES EVEN IF YOU GIVE NOTICE OF THE POSSIBILITY OF SUCH DAMAGE.

1.F.3. LIMITED RIGHT OF REPLACEMENT OR REFUND - If you discover a defect in this electronic work within 90 days of receiving it, you can receive a refund of the money (if any) you paid for it by sending a written explanation to the person you received the work from. If you received the work on a physical medium, you must return the medium with your written explanation. The person or entity that provided you with the defective work may elect to provide a replacement copy in lieu of a refund. If you received the work electronically, the person or entity providing it to you may choose to give you a second opportunity to receive the work electronically in lieu of a refund. If the second copy is also defective, you may demand a refund in writing without further opportunities to fix the problem.

1.F.4. Except for the limited right of replacement or refund set forth in paragraph 1.F.3, this work is provided to you 'AS-IS', WITH NO OTHER WARRANTIES OF ANY KIND, EXPRESS OR IMPLIED, INCLUDING BUT NOT LIMITED TO WARRANTIES OF MERCHANTABILITY OR FITNESS FOR ANY PURPOSE.

1.F.5. Some states do not allow disclaimers of certain implied warranties or the exclusion or limitation of certain types of damages. If any disclaimer or limitation set forth in this agreement violates the law of the state applicable to this agreement, the agreement shall be interpreted to make the maximum disclaimer or limitation permitted by the applicable state law. The invalidity or unenforceability of any provision of this agreement shall not void the remaining provisions.

1.F.6. INDEMNITY - You agree to indemnify and hold the Foundation, the trademark owner, any agent or employee of the Foundation, anyone providing copies of Project Gutenberg™ electronic works in accordance with this agreement, and any volunteers associated with the production, promotion and distribution of Project Gutenberg™ electronic works, harmless from all liability, costs and expenses, including legal fees, that arise directly or indirectly from any of the following which you do or cause to occur: (a) distribution of this or any Project Gutenberg™ work, (b) alteration, modification, or additions or deletions to any Project Gutenberg™ work, and (c) any Defect you cause.

Section 2. Information about the Mission of Project Gutenberg™

Project Gutenberg™ is synonymous with the free distribution of electronic works in formats readable by the widest variety of computers including obsolete, old, middle-aged and new computers. It exists because of the efforts of hundreds of volunteers and donations from people in all walks of life.

Volunteers and financial support to provide volunteers with the assistance they need are critical to reaching Project Gutenberg™'s goals and ensuring that the Project Gutenberg™ collection will remain freely available for generations to come. In 2001, the Project Gutenberg Literary Archive Foundation was created to provide a secure and permanent future for Project Gutenberg™ and future generations. To learn more about the Project Gutenberg Literary Archive Foundation and how your efforts and donations can help, see Sections 3 and 4 and the Foundation information page at www.gutenberg.org.

Section 3. Information about the Project Gutenberg Literary Archive Foundation

The Project Gutenberg Literary Archive Foundation is a non-profit 501(c)(3) educational corporation organized under the laws of the state of Mississippi and granted tax exempt status by the Internal Revenue Service. The Foundation's EIN or federal tax identification number is 64-6221541. Contributions to the Project Gutenberg Literary Archive Foundation are tax deductible to the full extent permitted by U.S. federal laws and your state's laws.

The Foundation's business office is located at 809 North 1500 West, Salt Lake City, UT 84116, (801) 596-1887. Email contact links and up to date contact information can be found at the Foundation's website and official page at www.gutenberg.org/contact

Section 4. Information about Donations to the Project Gutenberg Literary Archive Foundation

Project Gutenberg™ depends upon and cannot survive without widespread public support and donations to carry out its mission of increasing the number of public domain and licensed works that can be freely distributed in machine-readable form accessible by the widest array of equipment including outdated equipment. Many small donations (\$1 to \$5,000) are particularly important to maintaining tax exempt status with the IRS.

The Foundation is committed to complying with the laws regulating charities and charitable

donations in all 50 states of the United States. Compliance requirements are not uniform and it takes a considerable effort, much paperwork and many fees to meet and keep up with these requirements. We do not solicit donations in locations where we have not received written confirmation of compliance. To SEND DONATIONS or determine the status of compliance for any particular state visit www.gutenberg.org/donate.

While we cannot and do not solicit contributions from states where we have not met the solicitation requirements, we know of no prohibition against accepting unsolicited donations from donors in such states who approach us with offers to donate.

International donations are gratefully accepted, but we cannot make any statements concerning tax treatment of donations received from outside the United States. U.S. laws alone swamp our small staff.

Please check the Project Gutenberg web pages for current donation methods and addresses. Donations are accepted in a number of other ways including checks, online payments and credit card donations. To donate, please visit: www.gutenberg.org/donate

Section 5. General Information About Project Gutenberg™ electronic works

Professor Michael S. Hart was the originator of the Project Gutenberg™ concept of a library of electronic works that could be freely shared with anyone. For forty years, he produced and distributed Project Gutenberg™ eBooks with only a loose network of volunteer support.

Project Gutenberg™ eBooks are often created from several printed editions, all of which are confirmed as not protected by copyright in the U.S. unless a copyright notice is included. Thus, we do not necessarily keep eBooks in compliance with any particular paper edition.

Most people start at our website which has the main PG search facility: www.gutenberg.org.

This website includes information about Project Gutenberg™, including how to make donations to the Project Gutenberg Literary Archive Foundation, how to help produce our new eBooks, and how to subscribe to our email newsletter to hear about new eBooks.