

The Project Gutenberg eBook of Through a Microscope, by Frederick Leroy Sargent et al.

This ebook is for the use of anyone anywhere in the United States and most other parts of the world at no cost and with almost no restrictions whatsoever. You may copy it, give it away or re-use it under the terms of the Project Gutenberg License included with this ebook or online at www.gutenberg.org. If you are not located in the United States, you'll have to check the laws of the country where you are located before using this eBook.

Title: Through a Microscope

Author: Frederick Leroy Sargent

Author: Mary Treat

Author: Samuel Wells

Release date: December 28, 2011 [EBook #38428]

Most recently updated: January 8, 2021

Language: English

Credits: Produced by Chris Curnow, David E. Brown and the Online Distributed Proofreading Team at <https://www.pgdp.net> (This file was produced from images generously made available by The Internet Archive)

*** START OF THE PROJECT GUTENBERG EBOOK THROUGH A MICROSCOPE ***

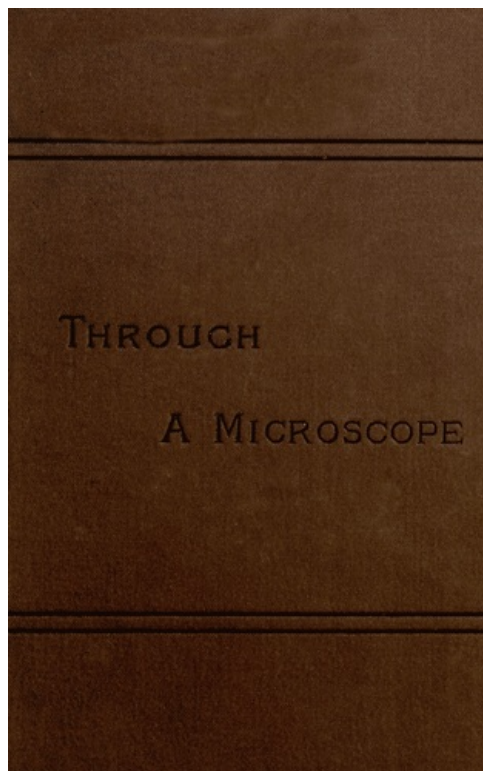

THROUGH A MICROSCOPE

SOMETHING OF THE SCIENCE
TOGETHER WITH MANY CURIOUS OBSERVATIONS
INDOOR AND OUT
AND DIRECTIONS FOR A HOME-MADE MICROSCOPE

BY

SAMUEL WELLS, MARY TREAT AND
FREDERICK LEROY SARGENT

CHICAGO
THE INTERSTATE PUBLISHING COMPANY
BOSTON: 30 FRANKLIN STREET

COPYRIGHT, 1886,
BY
INTERSTATE PUBLISHING COMPANY.

[2]

CONTENTS.

[3]

CHAPTER.	PAGE.
I. Through a Microscope	7
II. The Outfit	14
III. The Objects	20
IV. Home Experiments	26
V. Cochituate Water	33
VI. Interesting objects	39
VII. The Brickmaker	46
VIII. The Vorticellas	54
IX. The Utricularia	61
X. Free Swimming Animalcules	70
XI. On the Beach	78
XII. Rizopods	86
XIII. How to See a Dandelion	97
XIV. How to See a Bumble Bee	107
XV. Some Little Things to See	114

[4]

PART I
THROUGH A MICROSCOPE
BY SAMUEL WELLS

[5]

THROUGH A MICROSCOPE

[6]

[7]

I

An object one hundredth of an inch in diameter, or of which it would take one hundred placed side by side to make an inch, is about the smallest thing that can be easily seen by the unassisted eye. Take a piece of card and punch a little hole through it with the point of a small needle, hold it towards a lamp or a window, and you will see the light through it.

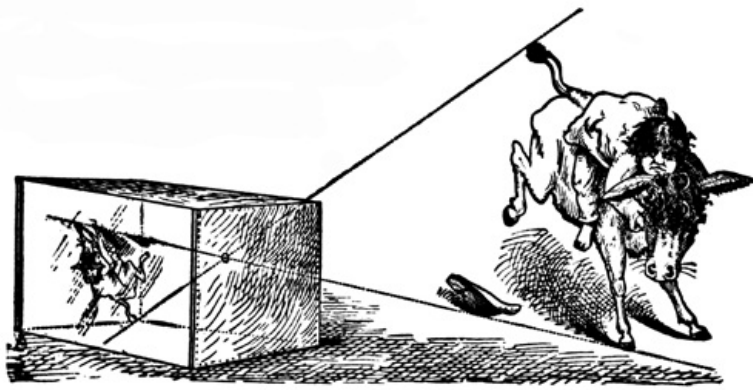

FIG. 1.

This hole will be about the size just mentioned, and you will find that you can see it best and most distinctly when you hold it at a certain distance from your eye; and this distance will not be far from ten inches, unless you are near-sighted. Now bring it towards your eye and you will find it becomes blurred and indistinct. You will see by this experiment that you cannot see things distinctly when held too close to your eye, or in other words, that you cannot bring your eye nearer to an object than eight or ten inches and see it well at the same time. [8]

You could see things much smaller than one hundredth of an inch if you could get your eye close enough to them. How can that be done? By a microscope? yes, but what is that? This name comes from two Greek words that mean "to see small things;" and a microscope is an instrument by which your eye can get very close to what you want to see.

To understand this, take out one of your eyes and look at it with the other one. You see that it is a little round camera; most boys have seen a camera and some boys can make one. The simplest way to do that is to take a box, say a cigar box (empty, of course); pull off the cover and fasten in the place of it a piece of ground glass if you have one: if not a piece of white letter paper, oiled, will do; bore a hole in the middle of the bottom with a small gimlet and your camera is done. [9] Point the bottom with the hole in it out of the window, and throw a piece of cloth over your head and over the box, as the photographers do, to shut out the side light, but mind and not cover up the hole; look at the ground glass (or oiled paper) and you will see things upside down. (Fig. 1.) But what has it to do with my eye? you say. Why, your eye is just like it, only round, as in fig. 2. And if you hold a doll or anything else about ten inches in front of the eye you have taken out and look at the inside of it (the eye, not the doll) just as you look at the ground glass of your box camera, you will see the doll upside down on the back of the eye.

But how, do you say, can I see things right side up when they are upside down in my eye? This is a very good conundrum and it will keep a long time, till you are about seventy years old and have spare time to sit down and think about it.

Now you see how your eye is a camera; the pupil is the hole and the back of the eye, called the retina, is the ground glass. [10]

But you will find that the camera you have just made does not show things distinctly and beautifully as the photographer's camera does; how can they be distinct in the eye then?

Because in the photographer's camera, in the hole is a lens, which is a piece of glass, shaped like a sun glass; and so in your eye just behind the pupil is a lens, not made of glass, but still almost as transparent as if it were. In order to see what effect this lens has, take your box camera, make the hole larger and put a lens in it; one of your magic lantern lenses will do; and if the lens has the right focus you will see the images sharp and distinct on your ground glass. The focus probably will not be just right, so make a paper tube, into which fasten your lens and slide the tube in and out of the hole until you find the right focus.

When you have got that right so that you see a boy on the sidewalk upside down and see his teeth when he laughs, put some small object, the little doll will do, about three feet in front of your lens, and you will find the image of it is blurred and indistinct, and that you must pull your tube out to get the focus on the doll; or if you had another lens of just the right shape to hold in front of your camera, you would with that get the focus on the doll. [11]

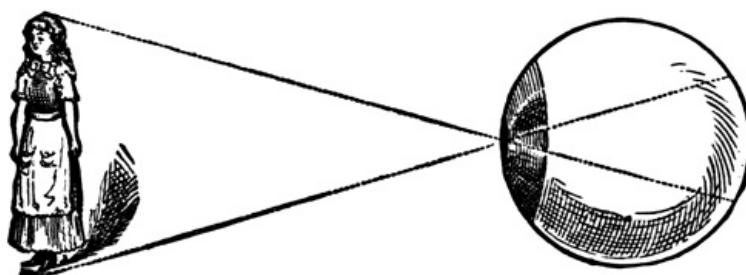

FIG. 2.

Thus you can see how it is with your eye, and why you cannot see things distinctly held close to

it. The lens in the eye can change its shape a little, so that it will focus objects a mile off, or ten inches off, but it cannot be pushed in and out like the tube in your camera. You can do this, however, if you take another lens and hold it outside your eye and let the light go through that first before it comes to the lens in your eye, and in this way you can get a focus in your retina, and the outside lens thus forms a part of that optical instrument called your eye. Does your grandma know that her spectacles are a part of the cameras that she calls her eyes?

How is it that a lens bends (refracts is the big word for it) the rays of light? You will learn by and by. You can see that it does so by a few experiments with your sun glass or any such lens. Hold it between the sun and a piece of white paper until the white spot in the centre is as small as you can make it. You will see that the rest of the lens casts a shadow although it is all glass; this is because the rays of sunlight that fall on the lens are all bent towards the centre, and so you have a small white spot on which is concentrated the light and the heat, and before you have found out how it is all done, your paper takes fire and the experiment ends in smoke.

Take another piece of paper, and when the white spot is at its smallest, measure the distance between the lens and the paper, and you will have the focal distance of the lens.

You have now found out how to get your eye close to an object and see something that is very small; this is usually called magnifying it, because it seems to make it look large. Suppose you have a lens that will let you see a flea through it held just one inch from it, this lens is now an addition to your eye, as we measure from the lens. If you had another flea held ten inches off, so big that it would just be hidden by the little flea, the one farthest off would be ten times as large as the near one. (Fig. 3.) In this case it is said that the lens having a focal length of one inch magnifies ten times, or has a power of ten.

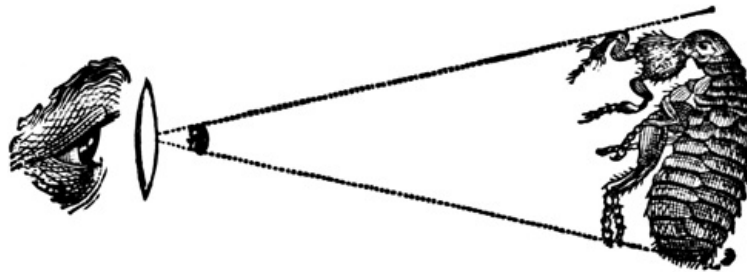

FIG. 3.

The shortest usual distance of objects seen distinctly being taken as ten inches, microscopists have agreed to consider that as the standard of measurement, and objects seen through a lens are considered magnified to the size they would have if projected ten inches off, like our little flea.

II.—THE OUTFIT.

Now that we have got hold of the idea that the eye is an optical instrument, and that to increase its capacity for seeing small things we add to it other optical contrivances, making with it one instrument composed of several parts, let us look at such additions more particularly.



FIG. 1

One pleasant September afternoon, three gentlemen were strolling along the banks of the Wissahickon, in Philadelphia's beautiful park, and stopping now and then to examine some little flower or insect with pocket lenses, when they discovered that some little boys out for a holiday were watching their proceedings with a curious and mystified interest.

One of the gentlemen had a pocket microscope with three lenses of different sizes, as in Fig. 1. Calling the boys up to him he showed them a little flower magnified. They had never dreamed of such a sight, and their wonder and amazement were as great as if they suddenly beheld a new world. You will be as surprised as they were when you take your first peep, but you must learn to see such things *by yourselves*. The first thing you need is a simple microscope, that is, one with a single lens, small enough to be carried in the pocket. There are different forms and sizes of such microscopes, varying in quality and price. Those like the one just mentioned are made with from one to four lenses each,



FIG. 2

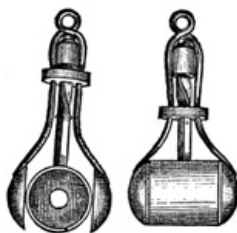

FIG. 3.—OPEN AND CLOSED.

and are perhaps the most generally useful. Then there is the Coddington lens (Fig. 2) which is still more compact; and it is sometimes made in the form of Fig. 3. It has a very short focus, and is not, therefore, very easy to use. Achromatic doublets and triplets are made of two or more lenses cemented together and mounted in the same style as the Coddington lens; they are very

much better than the Coddington, but are more expensive.

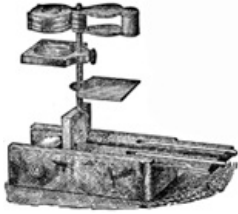

FIG. 5

There are several devices for mounting these simple microscopes on stands so that they can be kept steady and the objects to be examined placed behind them. One of these is illustrated in Fig. 4. An ingenious boy with a block of wood for a base, some stout wire and corks, can make one almost as useful, though not so handsome.

A more elaborate form is shown in Fig. 5. It has a glass stage to hold transparent objects, and a brass one for opaque objects, and a mirror below to reflect light up through transparent objects.



FIG. 4

[18]

It is much better to use a good simple microscope than a poor and cheap compound one; be sure and remember this and not be enticed to buy such an one by any representations as to its great magnifying power.

A compound microscope is one with a tube from four to ten inches long, an arrangement for holding the object to be looked at, and a mirror below to reflect light upon or through it. The lenses at the end next the object are small, and are set in a small brass tube, which is called an "objective." It screws into the large tube. The lenses at the end of the large tube next the eye are set in a tube, called the eye-piece, which slides in and out of the large tube. Different objectives contain lenses of different sizes according to the magnifying power desired, and they are named "two inch," "one inch," "half inch," and so on down to "one seventy-fifth." Eye-pieces are sometimes named "A," "B," "C," but more properly "two inch," and so on down to "one eighth." There is a very great variety in the forms of compound microscopes, from the very simple up to the very elaborate, and the prices vary accordingly. A simple but useful form is given in Fig. 6.



FIG. 6

[19]



CATCHING ANIMALCULA WITH A PIPETTE.

Some simple things, however, you will need at once, such as a few slips of glass three inches long and one inch wide, called "glass slides," some pieces of very thin glass, called "cover glass," a pair of tweezers, some needles fastened into pen-holders for handles, and a few glass tubes commonly called "pipettes," or "dipping tubes." These can be readily bought, and some of them easily made.

A great deal of money can be expended on a microscope and the various instruments made to use with it and which are called "accessory apparatus"; but it is best not to buy these instruments until you know just what you want, and not to spend much money at first except under the advice of a "microscopist."

III.—OBJECTS.

[20]

As soon as you have a microscope you will begin to look at everything and anything: dust, crumbs of bread, flour, starch, mosquitoes, flies, and moth millers in their season; flowers and leaves, cotton, wool, and silk. But this scattering kind of observation will soon weary you. In order to get the greatest pleasure and best results from your work, you must proceed with some system.



There are so many objects visible only through the microscope that life is not long enough for you to see them all, much less to study them. Some microscopists devote the time they have for such studies to the observation of single classes of objects; the physician observes the various parts of the animal structure, and calls his work "histology;" the botanist examines the vegetable kingdom; the entomologist, insects; but in all these departments there are numerous subdivisions. As a guide to your work, you will find some book on the microscope very useful; the best one is *The Microscope and its Revelations*, by Dr. William B. Carpenter.

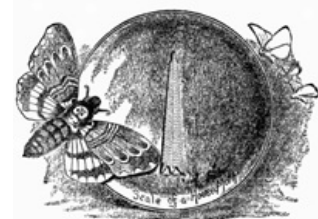

MAGNIFIED 50 DIAMETERS.

[21]

Objects through which you can see light are called "transparent," and are the easiest to look at with the microscope, because you can lay them on a

BULL'S EYE LENS. glass slide and throw light up through them with your mirror. Thick objects through which light cannot pass are called "opaque," and are more difficult to examine, and can only be seen with low powers and a bright light.

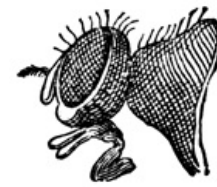

[22]

In order to see such objects in the evening, you will need a "bull's eye" lens mounted on a stand, which you can place beside your microscope and between the lamp and the stage, condensing the light of the lamp on the object. (Fig. 1.) There are other methods of illuminating opaque objects, but they are expensive and difficult to manage, yet by and by if you persevere in this delightful occupation you will learn what they are.

FLY'S EYE—5 DIAMETERS.

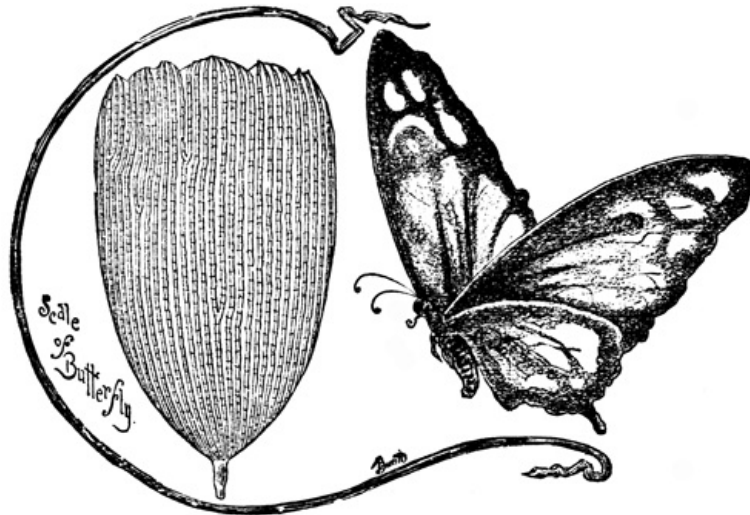

MAGNIFIED 200 DIAMETERS.

Some persons will expect you to show them a fly as big as a horse; but you will soon be able to prove to them that you know more about the matter than they do. With a large hand-lens, you can see a whole fly at once and magnify it two or three times; but when you put it on the stage of your compound microscope and try to magnify it still more, you will find that you can only see a part of it at a time, and the higher the power you use, the less can you see; in other words, the more you magnify an object, the smaller is the field of view.

[23]

[24]

An inch-objective will show the head of an housefly, which in a bright light is a very beautiful object. No picture can equal the delicacy of the color of the eyes of a live fly.



HEAD OF MOSQUITO. MAGNIFIED 15 DIAMETERS.



SECTION OF WOOD. MAGNIFIED 50 DIAMETERS.

After a little practise you will be able to separate the different parts of insects and look at them with higher powers. The moth fly will soon be on the wing, and your aunt will not call you cruel if you kill and cut up large numbers of them. Put a little of the dust that comes off from the wing of a moth on a glass slide, look at it with a high power, and you will find that each particle of dust is a pretty leaf-like scale. You have seen in summer the dust on the wings of butterflies; remember this, and look at this butterfly dust with your microscope.

[25]

Flowers and leaves you can always easily obtain; but in looking at them you must remember what has already been said about "transparent" and "opaque" objects.

Thin slices or sections of stems, leaves, and portions of flowers, can be made with a sharp knife, and examined as transparent objects, so that thus you can observe the internal or cellular structure of the vegetable kingdom.

IV.—HOME EXPERIMENTS.

[26]



FIG. 1.

During the cold weather it is not pleasant to make excursions into the country and search for objects for the microscope; so you will look about and see what you can find at home; and if you live in Boston, Cochituate water will invite your inspection. The best way to get at the minute objects in this or any water that is supplied through pipes, is to make a bag of cotton cloth, not too fine, well washed in water without soap, about a foot long, large enough at the top to slip over a faucet that has a screw on it (like the common kitchen faucet adapted for a filter), so that it can be tied with a string, and small enough at the bottom to be tied on to the neck of a small bottle such as is used for homœopathic pills. This bag should taper gradually in size from the top to the bottom. (Fig. 1.)

[27]

If there is a strong head of water where your faucet is, you must reduce the pressure by opening other faucets on the same floor, such as those in the laundry, otherwise many of the small creatures will be crushed in the interstices of the bag. Now let the water run. The bag will swell out and the water ooze through its sides, and all objects too small to pass through it will fall down and settle in the little bottle at the bottom. When you see that there is a considerable amount of sediment in the bottle, shut off the water and gently squeeze the bag between your thumb and forefinger, beginning at the top and moving your hand down towards the

[28]

bottle. This movement will cause much of the sediment that has adhered to the sides of the bag to fall down. Now untie your bottle and set it aside and let the water run through the bag to clean it. If you have a filter attached to your kitchen faucet you can get a very good idea of the solid contents of the water by unscrewing it, or turning it over if it is made so as to reverse, and letting the sediment that has collected on it drip into a tumbler, but the bag gives much better results, as many of the delicate forms that live in the water are crushed to death on the filter.

[29]

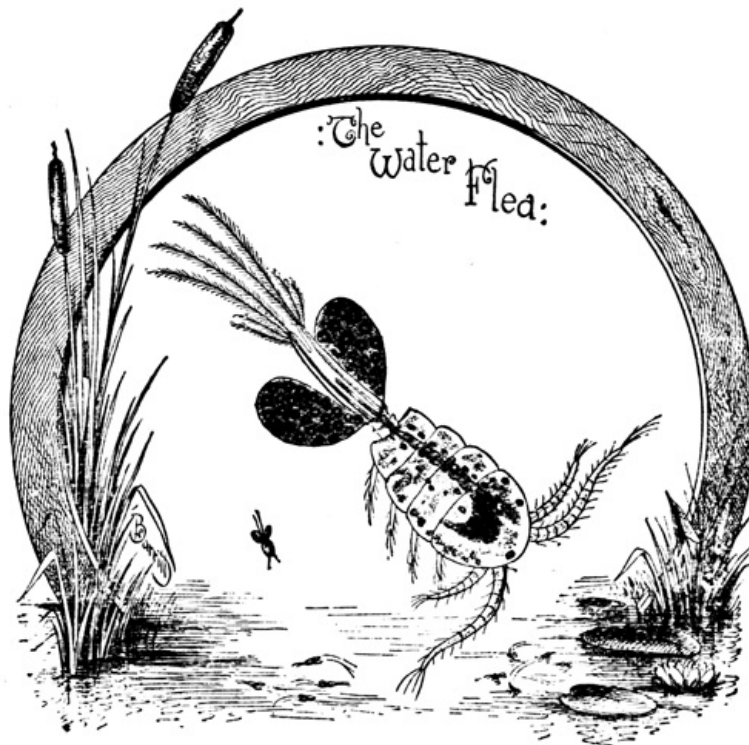

FIG. 2. CYCLOPS QUADRICORNIS. MAGNIFIED 20 DIAMETERS.

Having got the sediment in either a tumbler or a bottle, you must make your first observation on it with the naked eye by holding it up to the light and looking through it. You will find it of a brown color, because a large part of it consists of particles of earth and decayed vegetable matter, but you will presently see many little white specks moving about with a jumping or hopping movement. These are commonly called "water-fleas," on account of their peculiar movements, but the name is misleading, as they belong to the crustacea (animals having a shell or crust like the lobster), and not to the insects.

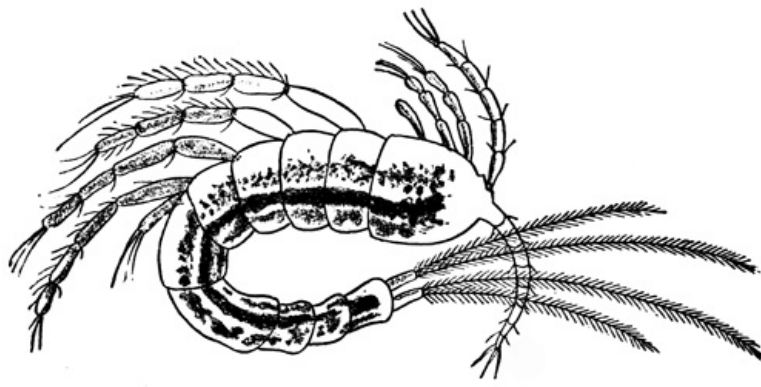

FIG. 3. CANTHOCAMPTUS MINUTUS. 40 DIAMETERS.

They are found abundantly in ponds and ditches, and in salt water. Sometimes they are so abundant in drinking water that has not been filtered, as to alarm a timid person, but you will find them just as good to eat raw as they are cooked. The most common of these little creatures is the *Cyclops Quadricornis*, so called because he has one eye and four horns. (Fig. 2.) [30]

This picture represents a female, and she carries her eggs in the two little black bags that you see fastened on each side of the abdomen. You will find it very interesting by and by to watch the eggs hatch and see the little cyclops hop away. When young they do not look much like their parents; they are rounder and their legs are more prominent. The female cyclops (the male is comparatively rare) is the most common creature in Cochituate water, and as it is constantly eating, it helps to purify the water, and, in its turn, is eaten by the fishes.

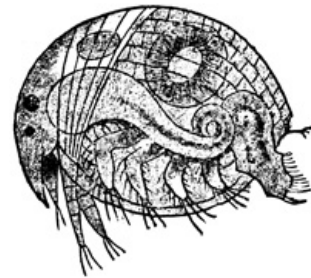

FIG. 4. CHYDORUS SPHÆRICUS. 50 DIAMETERS.

In swimming it contracts its four horns and its fringed feet with a quick movement that throws it forward through the water with a leap.

Its one eye is of a brilliant red, and is a beautiful object under the microscope. The shell also is sometimes beautifully colored, and is often transparent, so that the internal organs are plainly visible through it. [31]

Another of the family of *Cyclopidae* is the *Canthocamptus minutus* (fig. 3), which you see is longer and more tapering in its form than the *Cyclops Quadricornis*. It is also very common and very active.

Chydorus Sphaericus (fig. 4) is a very pretty round form interesting to study when transparent.

All these and some others with rather hard names are in that division of the *Crustacea* called *Entomostraca*, meaning shelled creatures whose shells are cut and do not cover them all round. On this principle, an oyster on the half-shell might be called an *Entomostracan*.



FIG. 5.

Now to catch these lively fellows, you must take a dipping tube and be patient, and when you have got one in the tube, carefully drop it on the bottom of the "live-box" (fig. 5), and put on the cover. Examine it first with the lowest power you have. By careful management of the cover you can catch it between the top and bottom without breaking the shell, and in this prison you can study it at leisure. [32]

V.—COCHITUATE WATER. [33]

You have read or been told that if you look at a drop of water through a microscope you will find it full of animalculæ, and showmen will sometimes exhibit water containing *entomostraca* hopping about, and will try to persuade you that all water looks in the same way.

But this is a common mistake, as you will soon find out for yourselves. Water such as is commonly used for drinking purposes, whether it comes from a well, spring, river, or pond, contains but little animal or vegetable life in proportion to its quantity; you may place drop after drop under the microscope without finding anything visible, and you can only tell what is in it by filtering a great deal of it. Water standing in ditches or pools for a long time, becomes full of growth of various kinds, and is then so discolored and slimy that no one would think of drinking it. [34]



**ROTIFER
VULGARIS.**

Let us return to the little bottle which you filled with Cochituate filterings last month. Take a little from the bottom with your dipping-tube; put it in the live box and examine it with a half-inch objective. You will see many forms that are strange to you, and we will suppose that the first is that of one of the rotifers. These little creatures are called by this name because of two Latin words meaning wheel-carriers, for on their heads they have an arrangement which looks like a wheel, sometimes in rapid motion.

The most common kind is called *Rotifer vulgaris* (fig. 1), and is a very interesting and elastic being. Sometimes he is gloomy and draws himself in so that he looks like a ball; then he will stretch out full length, and opening his wheel, shoot through the water with great speed. Again he will attach his tail to some fixed object, and by the aid of his wheel draw a rapid current of water through his mouth; it is thus that you can best observe him, and by and by you will discover that the apparent wheel is only a result of the rapid sweeping movement of the long hairs or cilia which fringe the opening in the top of the head. Through this opening the water passes, the rotifer gathers his food from the current, and the food passes into the mastax, where it is ground by the masticating apparatus, which is easily seen in motion.



**FLOSCULARIA
ORNATA.**

There are several different rotifers found in Cochituate water; among them the most common is the *Anuræ Stipitata*. (Fig. 2.) It is like a turtle, with a shell, or carapace, beautifully ornamented. You will see plenty of these empty shells, and sometimes you will find one inhabited, when you will see that the creature has a bright red eye, and several bundles of cilia, in front of the projecting spires.

One of the families of the rotifers is called *Floscularia*, because it resembles a flower; it is attached at the base to small plants, or algæ, and occupies a sheath so transparent that it is hardly visible. One species is occasionally found in the Cochituate, the *Floscularia ornata*. (Fig. 3.) It is a beautiful object, with its elongated radiating cilia, which remain quiet, and do not vibrate. The specimen figured has three eggs attached to its stem.

You will find other rotifers in the Cochituate, some formed like vases, others with long spires, but all graceful and beautiful. The *Dinobryon Tortularia* is sometimes very common in this water.

In October, 1881, when the taste of the water was very bad, the *Dinobryon* was very abundant, though we do not know that it had anything to do with the bad taste. You will see by the figure, that it is like a tree, with an individual of the family at the end of every branch. Each one has its own organs of existence, although attached to its brothers by its stem. Each has a bright red eye, and a long slender whip, called a *flagellum*, with which it lashes the water, and when all the *flagellæ* are in motion, the whole tree swims about. The individuals are very small indeed, and it will take your best objective to show the *flagellum*.

Another tree-like group is that of the *Vorticella*, of which you will sometimes find in the Cochituate, the species *Vorticella nebulifera*. Each animal is at the top of a stem, and this stem has the peculiar property of being able to coil up and draw its head down close to the bottom. This appears to be a defensive movement, for whenever a big ugly creature comes by, down go the whole family so quickly that your eye cannot follow the movement. Sometimes they will all bob down when you tap the stage of the microscope so as to jar them. At a certain period of its life the animal suddenly leaves its stem, and goes swimming about with great speed.

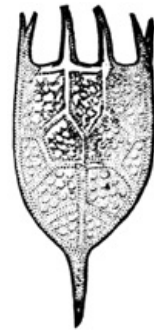

**CARAPACE OF
ANURÆ
STIPITATA.**

[35]

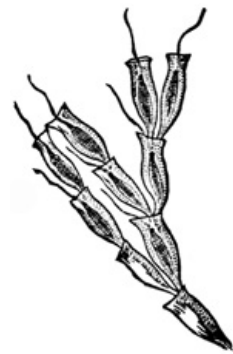

**DINOBYRYON
TORTULARIA.**

[36]



VORTICELLA NEBULIFERA.

[37]

[38]

VI.—INTERESTING OBJECTS.

[39]

The most beautiful of the small *algæ* or water plants are the *Diatomaceæ* and the *Desmidiaceæ*, sometimes called for brevity diatoms and desmids. They are remarkable for the geometrical character of their forms, consisting of circles, triangles and polygons of infinite variety. They are very small, and cannot be satisfactorily seen with an objective of less power than a four tenths. The diatoms are found everywhere in both fresh and salt water, but the desmids live only in fresh water. One of the most common diatoms in Cochituate water is the *Stephanodiscus Niagaræ*. (Fig. 1.) It is in shape like a pill box, and its sides, which would be called its top and bottom if it were a pill box, are beautifully ornamented with dots in radiating lines with a ring of spines near the edge. This circle of

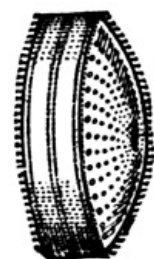

[40]

spines or thorns explains its name, *Stephanodiscus*, from the proto-martyr, Saint Stephen. The name *Niagaræ* is from Niagara River, where it was found. Like all diatoms, it contains when alive a yellowish brown matter with small globules of oil, which is called *endochrome*. The box or shell, called *pustule*, is of silex or quartz, and is therefore almost indestructible; and when the diatom dies, sinks to the bottom of the water. In this way beds of shells of diatoms are sometimes formed of considerable thickness.

**STEPHANODISCUS
NIAGARÆ**

[41]

Under the city of Richmond, Va., there is such a deposit, varying from ten to twenty feet in depth, and extending for many miles. Some of the diatoms, especially those shaped like a boat, called *Navicula*, have a peculiar motion which at one time led observers to think them animals. No one knows how this motion is produced, and if you can find this out, you will make a very important discovery. The most common diatom in Cochituate water is *Asterionella Bleakleyii*. It resembles a star with rays, or the hub and spokes of a wheel. (Fig. 2.) This diatom is often found in abundance in the water supplies of cities. It never forms a complete circle, but grows into spirals or whorls which easily break up.

[42]

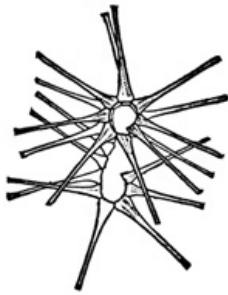

**ASTERIONELLA
BLEAKLEYII.**

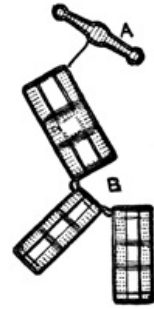

[43]

**TABELLARIA
FENESTRATA.**



SPONGILLA FLUVIATILIS.

Another diatom common in Cochituate is *Tabellaria Fenestrata*, which grows in ribbon-like forms. (Fig. 3.) The desmids resemble the diatoms in the geometrical character of their forms, but they have no shell of silex, and are therefore easily destroyed. They are readily distinguished at sight by the beautiful green color of the contained matter. In many of them there is a curious circulation of small particles, especially in the ends of those of a crescent or new-moon shape. This circulation can only be seen with a high power. Desmids are easily found in ponds and ditches; and there are several species in Cochituate. Among them is *Desmidium Swartzii* (fig. 4), and *Closterium moniliferum*. (Fig. 5.) Their beauty depends so much on color that they do not appear to advantage in the figures. You will find in examining the filterings of Cochituate water, many objects which have not been described in these papers, and among them many fragments of green filaments of the small plants belonging to the *confervæ* and the *oscillatoria*; sometimes you will find small round opaque forms of brown or green color, which are probably spores of plants of a larger growth; sometimes you will see the pollen of pine-trees which has fallen into the water and looks like three small balls fastened together; sometimes, though rarely, you may find one of those curious little creatures called water bears, or *tardigrada*; and you may be fortunate enough to catch a water spider.

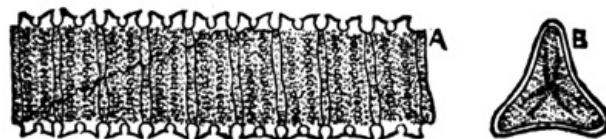

DESMIDIUM SWARTZII. FRONT AND SIDE VIEW.

[44]

But you will often see the *spiculæ* of the sponge, called *Spongilla fluviatilis*. They look like pins of glass, blunt at one end and pointed at the other, and are

[45]

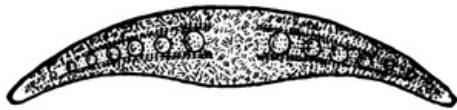

CLOSTERIUM MONILIFERUM.

sometimes very abundant. You may have heard that this sponge has been considered the source of the occasionally bad taste and smell of Cochituate water. When it is alive, it is not disagreeable, but when it decays it imparts to the water a very unpleasant taste and odor. It certainly is one cause of the bad quality of the water, but whether it is entitled to the sole credit is still open to question.

You can see what it looks like in *fig. 6*. When alive, it is of a light-green color, but when decayed it becomes brown. It is full of the *spiculæ* above described, which serve to stiffen it, but it easily crumbles and scatters them through the water.

Though the microscope shows us many beautiful and interesting objects, yet in the present state of our knowledge we cannot ascertain by its use whether the water we examine is harmless or injurious.

VII.—THE BRICKMAKER.

[46]

The microscope reveals so many strange odd-looking water creatures and plants that we can easily imagine ourselves transported to some new world. Look at this field of view as seen through the microscope. In the centre stands a brickmaker. He is a queer little animal, and so small that he looks like a mere speck to the naked eye, but through the microscope we see how wonderfully curious and strange a creature he is. He is no idle, lazy fellow. He is instead a most busy mechanic.

Just now he is building a house out of tiny bricks, and he manufactures the bricks himself, making them one at a time, and when one is finished he lays it down carefully by the side of the last, and fastens it firmly in its place with a kind of cement. The bricks are laid in regular tiers one above the other.

We find these brickmakers in still water where various water-plants grow, especially the water-milfoil and bladderwort. They seem to be social beings. They live in large communities, attaching their houses to the stems and leaves of the plants so thickly sometimes that they almost touch one another. They look, to the naked eye, like lines about one eighth of an inch in length. Sometimes they are very thick on the plants in New Jersey ponds.

[47]

If you take some of the plants and water, and put them in a bottle, you can carry a large number of the brickmakers home, where you can watch them at your leisure. Take a glass slide which has a little cup-shaped hollow to hold a few drops of water, and put a tiny piece of the plant with the house attached into this hollow and fill it with some of the water from the bottle. Now cover it with a very thin piece of glass and lay it over the stage of the microscope, and it is ready to be looked at and studied. You will look with both eyes, for your microscope is a binocular—one that has two tubes to look through. The size of the objects will depend upon the magnifying power you have chosen.

The first thing you see is a dark, brick-colored, cylinder-shaped house which looks to be about the size of a cigar. The little builder who lives in this house has been disturbed by the means we have taken to make his acquaintance; he has stopped work and gone within. But he is so industrious a fellow that he will not remain within very long. As soon as it is quite still he will probably come to the door of his house, and you will see him thrust out two horns. He will move these horns to the right and left, cautiously feeling all around him. He seems very cautious indeed. But at last he is satisfied that no enemy is near. Now he ventures out. He unfolds his wheels.

[48]

These wheels are surrounded with a band of *cilia*, or flexible hairs, which he can put in rapid motion, making the wheels have the appearance of revolving very fast. This rapid motion of the cilia forms a swift current in the water; and this current brings tiny particles of various things to the little mechanic. Some of these particles he uses for food; of others, he makes brick. They are carried into an opening between the wheels where you can see them revolving very fast until they are gathered into a little round, dark-colored pellet. The particles are probably held together by a sticky secretion made by the builder.

[49]

It takes him about three minutes to make a brick. As soon as it is finished, he bends his head over, takes it from its mould between the wheels, and lays it down carefully by the side of the last. Then he raises his head and begins to make another. The tube thus constructed is quite firm and strong. Sometimes when I have found a long tube, I have cut off a portion from the top. This can be done, with care, for the brickmaker drops to the bottom when disturbed. It is very amusing to watch him repair damages and rebuild. Sometimes I have forced one out of his tube, but it always soon died. But though industrious, he is so cautious, or timid, that he is easily frightened, and therefore he is often interrupted in his work. For instance, like some people that we know, he is very afraid of snakes. If a harmless little tiny snake comes wriggling along through the water anywhere near him, he folds his wheels and drops down into his house as quick as a flash. One day a little boy was delighted with the fast-revolving wheels. Suddenly, by and by, he turned toward me with great disgust plainly showing in his face: "He's gone in, 'fraid of a little snake!" he exclaimed.

[50]



FIGURE 1, BRICKMAKER; 2, CURRENT IN WATER; 3, 4, 5, 6, DIATOMS; 7, 8, DESMIDS; 9, ALGÆ; 10, 11, TRICHODA LYNCEUS; 12, SNAKE-LIKE LARVA; 13, PART OF PLANT TO WHICH BRICKMAKER IS ATTACHED; 14, BATRACHOSPERMUM MONILIFORM.

He is always a great favorite with those who have watched him through the microscope. I do not know how long they live, but I have kept the same individuals three months or more. I think no one knows the entire life-history of any of these little creatures, so here is a grand chance for any young microscopist to investigate and become famous.

[51]

On the left of the brickmaker in our field of view is a delicate, beautiful plant. Only a small part of it is seen in the engraving. It has a long, floating stem, thickly set with rosettes of a pearly green color. To the naked eye it looks like green slime, and is called "frog's spawn;" but the microscope shows us that it is a lovely plant, and some wise man has given us a long fine name to call it by if we choose—*Batrachospermum moniliform*. Let us see if this long name has any meaning: *Batrachia*, a frog, *spermum*, spawn; ah, after all, only another name for frog spawn! The other name, *moniliform*, means a bead-like necklace; and this was given it because the threads that make the rosettes look like strings of small pearly-green beads.

All of the strange-looking plants and animals that we see in the microscope are known as well by sight and by name by those who make them a study, as are the larger animals and plants that we see around us every day.

[52]

A bright little girl once asked me why such long hard names are given to everything in nature. We told her if there was but one language spoken in the world there would be no need of using Latin names. But as there are many languages, it was found necessary to agree upon some system, so that all peoples of different nations might have the same name for an animal or plant, and a long time ago all the civilized world agreed to use Latin names. Thus our little brickmaker is known all over the world as *Melicerta ringens*.

"A field of view" depends for its interest and variety upon what kind of water we put under the microscope. In the one here represented, I first took a tiny spray of plant with a brickmaker's house attached, and laid it on the hollow glass slide and then used the dipping-tube and brought up some of the sediment from the bottom of the bottle; this proved to contain several singular-looking plants and animals shown here.

Figures 3, 4, 5 and 6, are diatoms, and *figures 7 and 8* are desmids. Naturalists formerly placed both diatoms and desmids in the animal kingdom, but now all agree that the desmids are plants, while some few still maintain that the diatoms are animals. But the weight of evidence is on the plant side of the question.

[53]

The desmids are wonderfully beautiful plants; the markings and colors are exquisite. A number of species are found in the sediment of every swamp and pond.

The diatoms often grow in long ribbon-like masses (*fig. 3*), and then partially separate, remaining joined together at the angles so as to form a zigzag chain as seen at *figure 4*. They have the power of moving through the water, changing their places like animals.

A great variety of forms are found, both diatoms and desmids, many still undescribed, inviting the young microscopist to study and name them.

Figures 10 and 11 are different forms of a little animal, *Trichoda lynceus*. It undergoes a great many changes. In some of its stages, it looks so different from the figures here represented that you would never dream of its being the same creature.

VIII.—THE VORTICELLAS.

[54]



CARCHESIUM POLYPINUM.

The tree-vorticellas must ever stand first among all the varied and beautiful objects which the microscope reveals. A species common in New England and the Middle States is known scientifically by the name of *Carchesium Polypinum*. It is impossible to convey a true idea of its beauty from a dead black and white drawing. To be appreciated it must be seen in all its living glory—charming little animals resembling bell-shaped lilies on the ends of lovely transparent stems.

[55]

How curious nature is in the microscopic world! Only think of a tree of living animals! The stems of the tree are jointed, and the little creatures can sway the branches about and even throw them into a spiral coil so as to bring themselves near the main stem. This gives them the appearance of being very polite toward each other; they bow and courtesy as if preparing for a grand quadrille, and they are decked out in gay colors, red, green, and yellow. The margins of the little cups are fringed with hairs, or *cilia*, which they can put in such rapid motion that it makes a current in the water and brings little particles to their mouths which they consume as food. They do not accept everything that comes in the current. They seem to know what they like as well as the higher animals, and act as if they were vexed with some of the particles, rejecting and sending them off with a rapid whirling motion.

The largest of these fairy-like trees are visible to the naked eye, but it will be necessary for a novice in such matters to use a good strong lens to be able to find them readily. They are attached to plants growing in water. I have always been most successful in finding them among the water-milfoil (*Myriophyllum*) several species of which grow in New England and the Middle States. Some of the species are found in deep water, others in shallow ponds.

[56]

The Bladderworts (*Utricularia*) are also good plants to search among. They grow in similar places. On either of these plants we shall be sure to find a good many interesting creatures. If we fail to find the tree, we may secure other species of vorticella, all of which are very beautiful.

Do you know the *Utricularia*? I will devote the next chapter to these curious plants, and to the microscopic animals which they capture.

It will take a little practice to learn where and how to collect material for the microscope. We should not depend too much upon books in any branch of natural history. To be successful, you must observe for yourselves, experiment and examine independently, consulting books that you may name and classify, that you may recognize and name what you find. If you fail to find specimens in one spot, try another.

[57]

You should not fill your collecting bottles more than two thirds full of water, nor crowd too many plants in them. These little creatures must have air in order to live, as well as the higher animals.

The finest tree-vorticellas I ever found were in Florida, in the St. John's River. These trees were attached to long, floating stems of *Myriophyllum verticillatum*, and were unlike any species that I ever found at the North. They were very large—in a microscopic sense—plainly visible to the naked eye, and it took only a moderate power to bring out their beauty.



FIG. 2.

Vorticella nebulifera is quite common in swamps and ponds. We find it attached to a great number of water plants. This species is not built up in the form of a tree, but it is nevertheless beautiful and graceful. The delicate, slender stems start from a node, or rounded mass, sometimes fifty or more of these fairy like creatures in one colony, all attached to a common centre, swaying about, coiling their delicate transparent stems, and again uncoiling quick as a flash, apparently dallying and playing, but never interfering nor becoming entangled one with another.

[58]

The *Stentor* is another member of the *Vorticellinæ* family. It is one of the largest of the infusoria, plainly visible to the naked eye, and one of the most interesting and curious of all the strange animals in the microscopic world. It assumes various forms. When swimming, it looks round and plump (Fig. 2), and rushes through the water pell-mell, knocking the smaller animals right and left, always seeming to be in a great hurry, unless two friendly ones happen to meet, when they frequently stop and put their heads together a moment as if exchanging greetings, then away they sail again, dashing through the water, capturing and devouring the smaller creatures as

they go. And now a couple meet that are very communicative—two gossips, no doubt! At all events, they put their heads together and conclude to have a good sociable time.

And they are sensible enough to know that they cannot stand around loose in the water or public highway. So they select a cosey spot and fasten their feet to a plant or some firm object, and stretch out their footstalks sometimes to a great length, making veritable trumpets of themselves. (Fig. 3.)

[59]

And who knows what grave matters may be settled during these conclaves? or perhaps they are only rehearsing gossip, as they have had every possible chance to see what was going on among their neighbors.

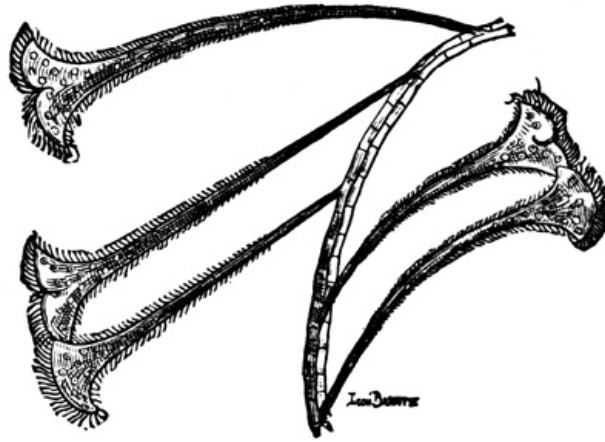

THE STENTORS.—"VERITABLE TRUMPETS."

Sometimes one settles down alone near a group of others, and seems to proclaim in stentorian voice that it is reception day and he is ready to receive. Or perhaps he is simply a herald as his name indicates, whose business it is to conduct ceremonies and regulate affairs! At any rate, though our ears are too dull to catch the voices of these curious beings of a lower world—so near, and yet in another sense, so far away, it would be difficult to believe that these animated creatures have no means of communication and nothing to communicate.

[60]

PART II THROUGH A MICROSCOPE

BY MARY TREAT

IX.—THE UTRICULARIA.

[61]

It seems strange that innocent-looking plants should capture and kill animals; but this is really what the Bladderworts (*Utricularia*) are all the time doing. They grow in ponds and swamps, some species in deep, still water, others in shallow ponds.

Fig. 1 shows a portion of the stem of *Utricularia clandestina*, natural size. The little bladders are so nearly transparent, that on bringing them under the microscope, or even under a good lens, you can see the numerous creatures that they have captured, some partly consumed, others still alive.

The bladders on these curious plants remind one of some of the *Entomostracans* which Mr. Wells described in his fourth paper. Look at *Chydorus sphericus* for instance, and then at the magnified bladder (Fig. 2) in this article. The branched horns at the mouth or entrance have very much the appearance of the antennæ of some of the minute animals, and the stem when it is attached to the main branch may be likened to a tail. But the way in which they capture and devour the pretty little creatures that come within their grasp makes them appear, even more than they look, like wicked animals.

[62]

I have found almost every swimming animalculæ with which I am acquainted, caught in these vegetable traps; and when caught they never escape. Their entrance is easy enough; there is a sensitive valve at the mouth of the bladder, which, if they touch it, flies open and draws them in as quick as a flash. These downward-opening bladders not only entrap animalculæ, but, more wonderful still, the strong larvæ of insects. The larvæ most frequently caught are those of the mosquito and chironomus. Often the mosquito is caught tail first—the entire body inclosed and the head left sticking out. It always looks as if the victim might walk or wriggle out, but it never does; and you may be sure that it never backed in there of its own accord.

[63]

You all know how the mosquito larva



FIG. 1. PORTION OF A STEM OF UTRICULARIA CLANDESTINA; NATURAL SIZE.

swims.

The chironomus is caught more often even than the mosquito larva. At certain seasons of the year it is almost impossible to find a bladder without one or more of these victims entrapped.

They feed on the water plants, and seem to have a special liking for the long-branched antennæ which grow at the mouth of the bladders, and, all unconscious of the trap, on, on they go, their sickle-shaped jaws cutting the antennæ which they eat as they advance, until their heads reach the mouth of the bladder, when they heedlessly touch the valve and the trap is sprung and they are drawn within, never more to escape, but to be slowly devoured.

There is another interesting species of *Utricularia*, the *Purpurea*, quite different in many particulars from the first. It grows in deep, still water. The stems are long, sometimes two feet or more in length, and the branches radiate in every direction, so that one plant often covers quite a large surface of water. The flowering stems stand above the water, and each stem bears three or four very pretty violet purple flowers, and it blossoms nearly all summer.

The flowers are about half an inch broad and quite conspicuous. Most of the other species have yellow flowers.

There are no little thread-like leaves on this species, and the bladders are on the ends of the little branchlets, and they have no sharp-pointed antennæ as in the other species; but in their place is an elegant cluster of transparent glassy-like ornamental appendages. The ornaments are just above the entrance, and who knows but this is a contrivance set there to lure unwary creatures into the trap.

One of the most common little creatures that was caught in this trap, was the *Tardigrada*, or water bear. He looks like a tiny cub, but unlike his great namesake, he has eight legs, and he frequently slips out of his old skin and comes out in a new suit.

I often find them crawling in a forest of these plants, peering out of a thick jungle—now ascending a branch and out on a limb, holding fast with their long claws, and apparently looking around to see what they can find.

Now one seems to be attracted to this elegant glassy cluster of *Utricularia*. At all events he is soon pushing his head among the delicate stems, then stops a moment, standing perfectly still as if listening. Perhaps he hears the groans of his dying comrades, but all unheeding the warning, he steps forward, touches the fatal spring, when in he goes to perish with his comrades.

Young microscopists may like to know that the *Utricularia* can be preserved in the house a long time by putting the stems or sprays in an open, shallow dish of water where they will grow readily. I have kept the plants months together in a large glass dish where they looked charmingly beautiful and were the admiration of all who saw them. It is very interesting to watch their growth. The ends of the growing sprays unroll like

wriggles in the water, and is known by the common name of "wiggler," or sometimes inaccurately, "wiggler." Now just as sure as the tail of this wriggler strikes the mouth of the bladder, just so sure is he caught—drawn in by some unknown power quicker than you can speak.

There is yet much to learn about these curious plants. How it is that the valve or trap can so firmly hold these strong larvæ is still a mystery. I have seen a mosquito larva caught by the head when the first joint of the body was too large to be admitted through the entrance of the bladder, and have patiently watched its frantic efforts to escape, but it was never released. The more it thrashed about, the tighter grew the fatal trap until death put an end to its struggles.

The chironomus larva is quite unlike that of the mosquito. The chironomus has brush-like feet which it can withdraw from sight—a sort of telescopic arrangement—or extend when it wishes to crawl along the plants, while the mosquito wriggles and

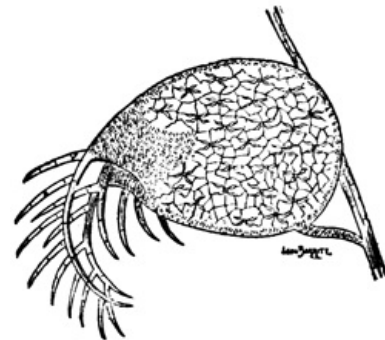

FIG. 2. BLADDER OF U. CLANDESTINA MAGNIFIED TWENTY DIAMETERS.

[64]

[65]

[66]

[67]

ferns, and with a magnifying glass you can see the development of the little bladders, and you may make discoveries—who knows? I know that for a long time it was a mystery to me how the bladders captured and imprisoned the little animals. Every day I saw they were entrapped and never escaped, and I studied and pondered over the matter a long time, and was so interested and determined to learn the secret that I spent night after night looking through the microscope, watching the strange, unwary creatures fall into the trap.

At last I concluded to adopt the following plan: I took sprays of the plants that I had grown in clear water that contained no animalcules, so that all the bladders were empty and quite transparent. In another dish I had put a great many masses of mosquito eggs. Mosquito eggs are found floating on almost any standing water, in dark, compact masses. In warm weather they hatch in a few hours. So you can understand how quickly I could swarm a small vessel of water with the mosquito larvæ by introducing the eggs where I wished them to hatch. When they were hatched I put some of the water in which was a large number of the tiny creatures into the live box with a spray of the plant containing empty bladders. I placed the box under the microscope and closely watched the manner of capture. I became certain that in almost every instance the larvæ were caught tail first. The tail is brush-like, and when it swept over the door or valve that leads into the bladder, I saw that the door would immediately fly open and always draw the larva in. I soon became satisfied that the valve was very sensitive when touched at the right point, but to this day I cannot tell what the power is that so quickly draws the creatures within. I earnestly hope that some young microscopists will yet be able to ferret out the cause of this singular power.

Those who have read Mr. Darwin's very interesting book on *Insectivorous Plants*, will have noticed that he says the valve of *Utricularia* is not in the least sensitive, and that the little creatures force their way into the bladders—their heads acting like a wedge. But this is not the case, as Mr. Darwin himself was convinced some years before his death. In his usual kind, gracious manner he admitted that he was wrong, and gracefully says the valve must be sensitive, although he could never excite any movement. In a letter to me bearing date June 1st, 1875, he says:

"I have read your article (in *Harpers Magazine*) with the greatest interest. It certainly appears from your excellent observations that the valve is sensitive.... I cannot understand why I could never with all my pains excite any movement. It is pretty clear I am quite wrong about the head acting like a wedge. The indraught of the living larva is astonishing."

X.—FREE SWIMMING ANIMALCULES.

The Brickmaker, Floscules, and Vorticellas are quiet peaceable citizens of the microscopic world, and seem to be impressed with the graver duties of life; they set up housekeeping and settle down for life moored to one spot. But there are many others that live a free-and-easy sort of life—a wandering gypsy kind of an existence, always on the move; and there is not much satisfaction in trying to follow these rovers if we wish to make a careful study of their structure.



SKELETON WATER WHEEL.

So to be enabled to examine them you will be compelled to imprison them in the live-box and bring just as much pressure to bear upon them as they will stand without crushing, which with careful practice you may soon learn to do. But if you are simply making the acquaintance of these little creatures for amusement, it is more interesting and satisfactory to watch them while they are unrestrained, and see the curious feats they perform.

One of the most amusing of these little animals is the Skeleton Wheel-bearer (*Dinocharis pocillum*). His portrait is seen at *Figure 1*. He has a long foot consisting of three joints, and these joints are as perfect as those of our own knees and elbows, and can be moved as easily forward and sideways, but not backward. The joints and foot are not covered with any fleshy substance, from which fact—the joints being so conspicuous—it probably received the name Skeleton. Two long slender toes extend from the last joint, and from the tips of these the Skeleton can show us more wonderful feats than any circus performer.

The toes can be widely separated, or brought close together, like a pair of tongs. Sometimes he stands on the tip of one toe and throws his body forward, or from side to side with a rapid motion; then straightening himself up, he stands on the tips of both toes as if posing, remaining perfectly still for a few moments and giving us an opportunity to take a good look at his curious body which is encased in a pretty vase-shaped, three-sided transparent shell. The head extends

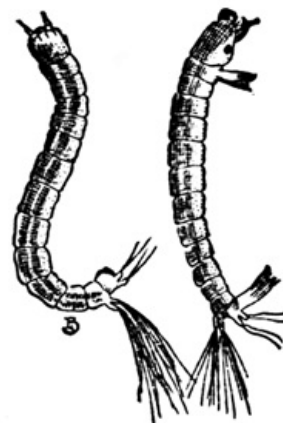

FIG. 3. CHIRONOMUS LARVA: BACK VIEW WITH FEET DRAWN IN AND JAWS CLOSED; SIDE VIEW WITH FEET EXTENDED AND JAWS CLOSED.

[68]

[69]

[70]

[71]

[72]

from the top of the vase, and is surmounted with the usual cilia, or wheel, which we see among all the rotifera. When he is tired of posing, away he swims in a graceful, easy manner, with his long foot straightened out and the toes brought close together.

You sometimes will find these pretty creatures, especially in summer-time, very numerous in the sediment at the bottom of your collecting bottles. Often I have found dead specimens, and very beautiful objects they sometimes are. Great numbers of tiny scavengers have completely cleaned out all of the soft parts of the body in a most neat and perfect manner, leaving the beautiful shell and vertical column, that runs through it, and the foot and toes, entire and perfect in all of their parts.

Think of the minuteness of these scavengers—untold numbers of them preying upon the body of an object invisible to the naked eye; and yet this body is a mammoth by the side of one of the scavengers! The mind can scarcely grasp the minuteness of these tiny creatures—creatures that seem to enjoy existence, eating, and apparently playing and entertaining each other like the higher animals. [73]

The whiptail (*Mastigocerca carinata*) (Fig. 2) is another delicate pretty little creature, and, like the skeleton, is encased in a glassy shell. It has a long, tapering, spine-like foot, or, more properly speaking, a toe which is attached to a very short foot by means of a flexible joint which allows free motion. You often will find him in company with the Skeleton, and they seem to vie with each other in performing strange feats. The Whiptail, if possible, looks even more comical than the Skeleton when it stands on the tip of its long toe, a toe which is longer than the entire length of the body, now bending over and nibbling at the plants, now whisking around as if looking and inquiring into some passing object, then sailing through the water with a graceful, easy motion beyond sight. [74]



WHIPTAIL.

Brachionus pala is also a lovely creature encased in a delicate transparent shell. It is considerably larger than the Skeleton or Whiptail, and is just visible to the unassisted eye. If you drop it in a phial of clear water and hold it up to the light, you can distinctly see it gliding through the water like a revolving white speck. A moderate power of the microscope reveals its beauty. The shell is swelled at the sides, and narrow at the mouth, and round over the back, while the under side is flat.

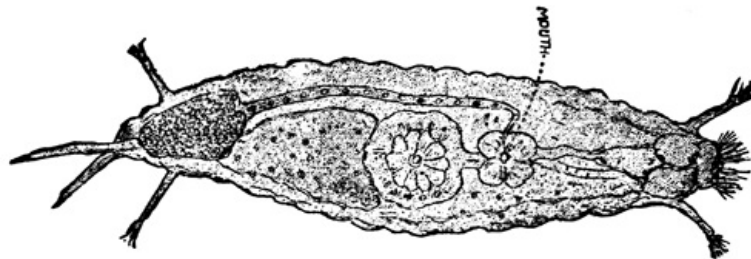

LARGE ROTIFER.

Like the Skeleton and Whiptail, the head of the little Brachion is seen protruding from the upper part of the shell; but instead of one wheel this charming little creature has two, and nothing can be more lovely than a sight of these fast revolving wheels, like two beautiful crowns. [75]

The reason the wheel looks so strikingly beautiful in *Brachionus* is owing to the long cilia which is longer in this genus than in other genera of this great family.

The foot of *Brachionus* is more curious than that of the Skeleton. It is telescopic, and the little animal has the most perfect control over it. He can draw it within the body so that it looks like a ball, and again quickly thrust it out and whisk it around in all directions like a tail. It has two short toes at the end which can be separated or brought together at pleasure. And he can firmly anchor himself by the toes and stretch forward, showing you the great length of the foot. Now he rolls from side to side without letting go his hold and performs other strange feats, and all the while the wheels are rapidly revolving, he has stopped his headlong career through the water and has settled down to get his supper.

Fig. 3 represents one of the largest rotifers with which I am acquainted. I have never been able to find a description or engraving of it in any work on microscopy. But it is probably well known to microscopists, for it has a wide range. I have found it in New Hampshire, New Jersey and Florida. [76]

You cannot get a true idea of its graceful beauty from the drawing, as it is represented as it was seen in the live box with sufficient pressure upon it to keep it from moving, while serving as a model. And no engraving, however perfect, can give you any idea of its brilliant transparency and delicate coloring.

The play of the muscles and internal organs are plainly visible, and you can always tell what he

has chosen for dinner. Diatoms and desmids form a portion of his diet. His mouth is below the wheel. When he is hungry he anchors himself by his forked tail and sets his wheel in rapid motion, which makes a powerful current sufficient to bring quite large objects to his head, frequently too large to admit into the mouth. He will often repeatedly try to take a desmid entirely too large for his mouth, and his manœuvres are quite comical as he whirls it round and round, nipping it on all sides. You will see by looking at the figure that everything has to be swallowed or taken within the body before it reaches the mouth. While the desmid is within the body the rotifer has control over it sufficient to take it into the mouth if it is of the right size, but if it is too large he soon becomes disgusted and ejects it with a sudden movement which sends it whirling rapidly away. And now he takes a smaller one and his jaws work vigorously a moment or two, when he swallows it almost entire, and we can plainly see the pretty markings and brilliant green color after it has passed into the stomach.

[77]

This large rotifer is plainly visible to the naked eye, and you will find it in both shallow and deep ponds, wherever water plants grow, during the months of July and August.

XI.—ON THE BEACH.

[78]

Many of our young people spend the month of August at the seaside, and if those who wish to learn something of the curious microscopic animals will stroll along the beach when the tide has receded, until they come to rocky places and little pools filled with salt water and various marine plants, they will find a form of animal life quite different from that in fresh water ponds. These little pools along the rocky coast are the homes of countless numbers of zoophytes—animals which have a stronger resemblance to plants and flowers than any we have found in fresh water.

Look for specimens for microscopic work on the surface of the rocks, on dead sea shells, and on the sea-weeds. On the sea-weeds you will often find a white filmy network which to the unassisted eye looks like simple white threads running and spreading in every direction, and at every angle of the network a tiny stem shoots up, branching out like a tree and making a miniature forest.

[79]

Now if you apply a low power of the microscope, you will find the little forest is made up of a strange animal called *Laomeda geniculata*. (Fig. 1.) Each branch of this compound animal terminates and expands into a lovely vase and is the home of a polype. The polype is not a separate individual any more than the end of a growing branch is separate from the tree on which it grows.

When the creature is hungry he sends out from the margin of the vase from fifteen to twenty tentacles, ranged around the rim like the petals of a flower. *Figure 1* shows one of these expanded polypes as seen through the microscope.

The tentacles or feelers are fishing rods to bring game to the fleshy mouth which is protruded from the centre of the vase. A great many such mouths surrounded with their tentacles are necessary to feed this singular compound creature.

All that I can tell you of these microscopic animals will be nothing compared to a study of them with your own eyes, so I will only give you hints of what you may expect, thereby hoping to create sufficient interest to induce you to stroll to out-of-the-way places, where you may find many of Nature's marvellous works. We want more field workers in every department of Natural History, and especially in microscopy where unexplored fields are awaiting you.

When the tide has receded, various objects of interest will meet your eye at every step. Look at that old dead sea shell covered with a rough, shaggy nap. Ah, as we approach, the shell is moving off! What can it mean? Why, it means that a hermit crab has set up housekeeping in the old shell, and he, no doubt, thinks us suspicious characters and wants none of our company. But we are after microscopic objects now, and this hermit, interesting as he is, is not to claim our attention to-day. The rough coat on the outside of the shell is of more interest.

With the aid of a pocket lens you will find it another zoophyte. You can see the polypes, as thick as they can well stand, rising erect and straight from the shaggy coat like a miniature field of wheat. With a higher power you will see that each mouth is surrounded with tentacles like those of *Laomeda*, but yet it is quite a different looking creature. If we touch one of these polypes ever so lightly, the great army immediately close their tentacles, for the same life pervades the entire colony, and those on the extreme outer edge feel the contact as quickly as the one we touched.

One of the most comical and amusing creatures of all the zoophyte tribe, is figured and described by Mr. Gosse under the name of *Lar Sabellarum*. He was the first observer of this curious creature; he found it inhabiting the outer edge of the tube of a worm—the Sabella. So when you are looking for microscopic objects do not overlook any tube that you may see standing above the surface of sand and mud, as it may be surrounded by this singular zoophyte. The tubes usually extend an inch or two above the surface, and about as far below. I have found the tubes surrounded with the creatures, but not in as good condition for investigation as those Mr. Gosse mentions. Mine were too thick and crowded to distinguish

[81]

[82]



LAOMEDA.

[80]

clearly. But as Mr. Gosse describes them, they have a most close resemblance to the human figure as they stand erect around the mouth of the tube of Sabella.

A loose network surrounds the top of the tube and the strange forms spring from the angles of the meshes. The creatures are furnished with heads, and immediately below the head are two arms. (Fig. 2.) The head moves to and fro on the neck, while the arms are tossed wildly about as if gesticulating in the most earnest manner. Or, as in the wild and disorderly dances of savages the body sways back and forth while the arms are thrown upward and downward in a frantic way.



LARES.

One summer I found a colony standing so thickly together that they did not show off to very good advantage. Apparently they were like a packed army of Liliputians, striking out with their arms and struggling with one another. But when I came to observe them more carefully, I found they were not interfering with one another at all, but each was intent on his own business of obtaining a livelihood.

[83]

The Sabella which inhabits the tube, is of itself a most attractive object. Most elegant fringed filaments proceed from the head, and wave back and forth like a fan, and near the ends of these delicate slender filaments are little black balls, supposed to be eyes. If they are eyes, the Sabella has no lack of vision, and this may account for his seeming watchfulness. He is always on the alert and drops down into his house at any approach. Only with the utmost caution will you have an opportunity to leisurely look at his rare beauty.

When for the first time I saw this elegant, beautiful creature rising out of the tube, and waving its fringed fan-like filaments, I did not wonder at Mr. Gosse's enthusiasm. Neither was I surprised that he should be reminded of the old Roman mythology and call the zoophytes which surround the tube, "Lares," for the rare beauty of Sabella would suggest the protection of guardian spirits. He says:

"These curious creatures have afforded much entertainment, not only to myself, but to those scientific friends to whom I have had opportunities of exhibiting them. When I see them surrounding the mansion of the Sabella, gazing, as it were, after him as he retreats into his castle, flinging their wild arms over its entrance, and keeping watch with untiring vigilance until he reappears, it seems to require no very vivid fancy to imagine them so many guardian demons; and the Lares of the old Roman mythology occurring to memory, I described the form under the scientific appellation of *Lar Sabellarum*. You may, however, if it pleases you better, call them 'witches dancing round the charmed pot.'"

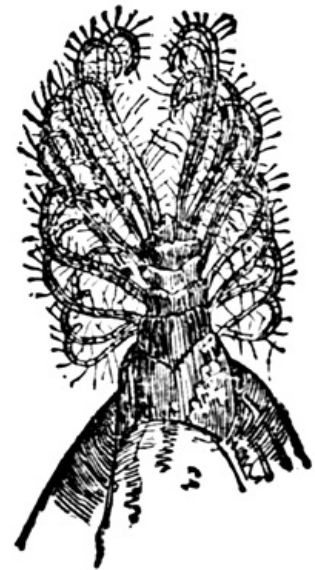

HAND OF BARNACLE.

[84]

When the tide is out you will frequently notice barnacles adhering to the rocks, or to the timbers used in the construction of wharves. Pray stop and examine them critically and see what admirable fishers they are. Their fishing-nets are composed of several long, flexible, jointed fingers, thickly beset with sensitive hairs. When the fisher wants a meal he thrusts his long hand (Fig. 3) out the door of his stone house; the sensitive fingers quickly tell when they come in contact with anything good to eat, and they curl over and grasp it and convey it to the mouth.

[85]

These barnacles are wonderful creatures and well worthy your continuous study. They pass through several stages. When young they are a gay rollicking set, swimming freely in the water; but as maturity approaches they settle down in stone houses, never more to rove about, and set up fishing for a living.

XII.—RHIZOPODS.

[86]

Rhizopods are the lowest creatures in the animal kingdom. Some of them are apparently nothing more than animated protoplasm. Protoplasm pertains to the first formation of living bodies, whether vegetable or animal, and it appears to be only a viscid, glutinous, unformed mass of jelly-like substance, yet these rhizopods seem endowed with something more than simple life.

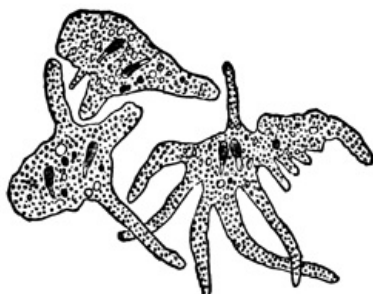

Let us take the lowest of these lowly creatures, the *amoeba*, or proteus, which we may find during the summer in almost every fresh water pond. I cannot describe it, for, like its namesake, it is constantly changing its form, slipping away from us, as it were, right before our eyes, and assuming a new shape. As Proteus of old could assume any form, either plant or animal as he pleased, so our

[87]

FIG. 1. AMŒBA PRINCEPS, IN DIFFERENT FORMS. *amœba* can assume various forms at pleasure.

You will remember that Homer introduces Proteus in the fourth book of the *Odyssey*. He makes him the servant of Neptune, and says his office was to take care of the seals or sea-calves. And who knows but his namesake may have some such office among the curious beings of the microscopic world which is peopled with as many strange creatures as those we read of in ancient mythology?

We frequently see our proteus adhering to a leaf of some water plant when it looks like a little ball of jelly; and while we are looking at it, it pushes out an arm here, and now another there, and still another, as if feeling for something. (*Fig. 1, Amœba princeps.*) Not finding anything to its taste, it moves or crawls along with its temporary arms extended—all the while changing them, throwing one out on this side, then on that, then contracting and pushing out in another place. It seems to be actively in search of something. At last it has reached a moving diatom with one of its long arms, which it immediately wraps around it, and now the other arms are contracted and the creature actually folds itself around its dinner! He turns himself outside in, and makes a temporary stomach, and proceeds to digest the soft parts of the diatom. After he has extracted all the nourishing part, he squeezes or pushes out the clear, transparent shell, and starts in search for something more.

[88]

It is not known to a certainty how the *amœbæ* are produced, but this much is known: If a portion of the body is detached from the rest, it does not die, but becomes an independent *amœba*. If a portion of one of the arms becomes separated from the main body, it does not seem to incommode the creature in the least, and the small part soon begins to extend tiny arms and behave in every way like its parent. And this may be the only way in which the children of Proteus are made—veritable children of his own flesh.

How strange it seems that a jelly-like mass of substance without form or organization should be endowed with life and sufficient sense to go in search of food and have the power of selection.

Life manifested in the lowest animal or plant is just as wonderful and hard to understand as that which pervades the higher animals.

[89]

Some of the species of the fresh water *amœba* live in shells of various forms and patterns. One which we often see has a little house made of tiny particles of sand and minute bits of shell soldered together with a kind of cement which hardens in water; these are vase or pitcher-shaped and always look rough on the outside.

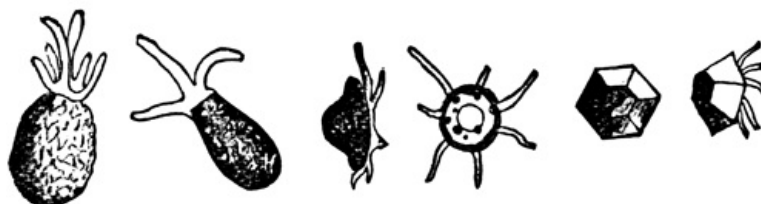

FIG. 2. TESTACEOUS FORMS OF AMŒBAN RHIZOPODS.

We may always know the different species by the forms and patterns of the shells in which they live. Some have very regular shells and prettily marked. These are usually rounded or arched on one side and flat on the other.

When you are looking for various microscopic objects in pond water you will often see these tiny shells among the sediment on your slides, and if you will patiently wait a few moments you will soon see delicate, transparent arms slowly pushing out on every side like cautious feelers. (*Figure 2, Amœba in Shell.—Carpenter, p. 445.*)

[90]

But the most beautiful forms, and by far the greatest variety of these microscopic shells are found in the ocean and in marine deposits. If we look at the seaweeds which grow on the rocks we may see many white specks adhering to every part of the plants. With a lens we find the minute specks are spiral shells of many species belonging to the class *Foraminifera*, and very closely allied to the *amœba*. The shells are of most elegant form and pattern. The large sea-shells which we so much admire are not half so lovely in form or color as these seen through a microscope. Some of the living animals and the castles in which they dwell are crimson in color, others a delicate pink.

Let us take one of these living shells while it clings to the sea-weed and carefully cut off the smallest portion of the plant to which it adheres, so as to disturb the occupant as little as possible; and now place it in the live box with some of the salt water and we shall soon have a most beautiful sight.

[91]

See, the creature is throwing out delicate, transparent threads or filaments in every direction, like fine-spun glass. How charming it looks with the beautiful shell in the centre, surrounded by this moving, filmy halo, and how slowly and cautiously the filaments are extended! He is not a heedless, reckless creature, rushing into needless danger, but a quiet, timid citizen. Although he was such a long time throwing out his misty arms, when he scents danger he withdraws them as quick as a flash. The least jar of the live-box, or a little wriggling larva—much too large for him to manage, however—are sufficient to make him take in all of his lines; but when quiet is restored,

they are again stretched out. And for what purpose are these slender filaments extended? Ah, an innocent animalcule has become entangled among the shimmering, filmy threads, and now the threads coalesce, run together like the arms of *amoeba*, and disappear, and the animalcule is drawn within the walls of the beautiful castle, and we are left to conjecture the fate of the little victim. *Figure 3, Rotalia Ornata*—which shows its delicate filaments extended.

[92]



FIG. 3. ROTALIA ORNATA.

These tiny creatures have been so numerous way back in the early ages of the world, that entire strata of rocks, several feet in thickness, in various parts of the world, are made up of their skeletons. The city of Richmond, Virginia, is built over rocks, composed largely of the minute fossils of *Diatomaceæ* intermingled with the *Foraminifera* and others.

A single prepared slide of these fossils will afford entertainment for an entire evening, so great is the diversity of form and so many hundreds on one slide. The Bahama Islands furnish the finest specimens of these fossils. The slides can be procured of any large dealer in optical instruments, or, what is still better, the young microscopist can soon learn to prepare them for himself, as ample directions are given in the books on the microscope.

In bidding my young readers adieu I shall not lose entire thought of them, but often when I am engaged in looking through the microscope, I shall think and ask myself, "Are they, too, absorbed in this pleasant work, and how many will become true workers and original investigators in this great field?" We shall all know in due time, for no earnest worker in any branch of science can long remain unknown. He will be found out sooner or later. A devoted student in microscopy will become so happy over the marvellous creatures and their curious ways that he cannot keep his pleasure to himself.

[93]

[94]

PART III

[95]

A HOME-MADE MICROSCOPE, AND HOW TO USE IT

BY FREDERICK LEROY SARGENT

[96]

XIII.—HOW TO SEE A DANDELION.

[97]

A simple microscope, some mounted needles, a sharp knife and a pair of small forceps, are the only things needed to begin with.

There are many kinds of simple microscopes sold, some of which are of moderate price and answer every purpose; but if one has a little mechanical skill the cheapest way is to buy a magnifier and make the rest of the microscope one's self. What is known as the "bellows pattern," with three lenses, is one of the best of the cheaper forms of magnifiers, and is an admirable little instrument.

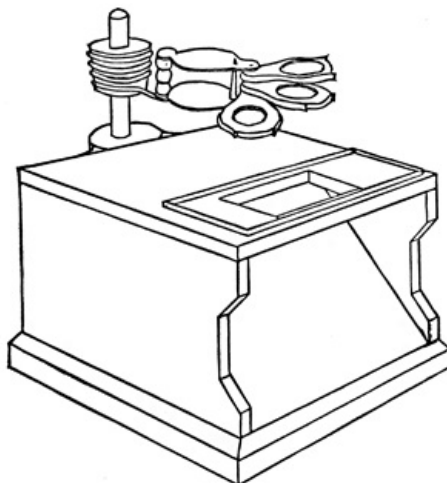

FIG. 1.

Fig. 1 shows a home-made microscope ready for use. It will be seen that the main part consists of a wooden box having a hole in the top and open in front. To the back is attached a cork by means

of a piece of thin metal as shown in *fig. 2*. Through this cord slides a rod on which slides another cork. A piece of brass wire has one end wound round the upper cork while the other end projects as an arm at right angles to the rod, and this projecting end sharpened and upturned, passes through holes drilled in the handle of the magnifier, and thus supports it. The lenses are focused, *i. e.* brought to the right distance from the object viewed, by sliding the cork up and down on the rod. [98]

The object rests on a piece of glass laid over the hole in the top of the box. A piece of wood covered with white paper and placed below the object at an angle of about forty-five degrees answers for a reflector to illuminate those objects through which the light can pass. The pure white surface is better for the purpose than a mirror. [99]

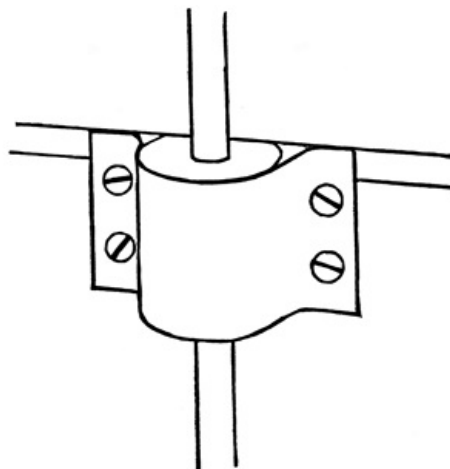

FIG. 2.

The most delicate part of the construction is making the holes in the corks for the rod to slide through. This may be done perfectly, however, by making the holes with a rat-tail file, trying the rod now and then until it moves just right. The best thing for the rod is a piece of brass wire one quarter of an inch thick; a lead pencil however is a good substitute. Before bending the end of the brass wire arm it is well to heat it red-hot at the point of bending, to take out the temper: as otherwise it may break. The holes in the handle of the magnifier should be drilled as near the front as possible and so arranged that when the magnifier is in position the smallest lens will be near the object. [100]

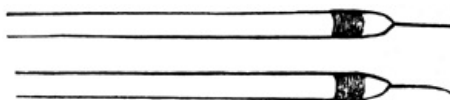

FIG. 3.

The mounted needles are shown in *fig. 3*. One pair of each kind will be enough to start with. To make one, take a fine needle, break off about a third, so it will not be too long and springy; then with a pair of pincers force it into the handle point first, withdraw it and finally force it in again with the point out. It may be easily bent with the pincers by first heating it to redness in a flame. When bent, heat it red once more and plunge quickly into water to re-temper it. Rubbing on an oil stone may be necessary to remove roughness. Should the handles show any tendency to split, it would be well to wrap the end tightly with waxed thread. [101]

The forceps (*fig. 4*) may be purchased either of brass or steel at no great expense. Although not necessary it is more convenient to have them curved than straight.



FIG. 4.

If the reader will carefully follow the directions given below and endeavor to see for himself all the parts spoken of, he will probably have very little difficulty afterward in the use of the instruments just described; and the enjoyment he will have when he has learned how to examine little things, will amply repay for careful and persistent efforts at the start. Get a Dandelion in full bloom and also one that has gone to seed.

Have the microscope and the other instruments ready for use. The best place to work is on a table in front of a window where there is plenty of light, but not the direct rays of the sun.

Now cut the blossom in halves from the stem up. It will be seen that the stem is hollow and ends above in a cushion-like expansion. From the upper surface of this grow a number of little flowers, while from the sides there sprang two rows of little green organs that enclose the flower cluster like a cup. Remove one of the flowers with the forceps and place it in a drop of water on the glass stage of the microscope. Examine with one and one half inch power. [A] [102]

Be careful to get just the focus. You are now ready to see the general form of the flower. At the base is a little body with roughened sides and slightly narrowed above (the ovary). Springing from the top of the ovary are a number of fine bristles (the pappus). Inside the bristles is a yellow portion, tubular below and flat above (the corolla). Projecting from the tube of the corolla is a little yellow rod (the top of the stamens joined together); and coming from among the stamens are two slender recurved organs (the stigmas). [103]

Now take a mounted needle in each hand and holding one needle on the flat part of the corolla split open the tubular part with the other. By keeping the lower part spread open with the needles, you will see that a number of delicate yellow threads grow from the sides of the corolla and are connected with the yellow stamen rod. These threads are another part of the stamens. In the middle of the flower is a single thread-like organ (the style) which comes from the top of the ovary and passing through the stamens projects beyond them, divided into two stigmas.

Most of my readers have probably studied enough botany to know the names of the different parts of a flower, but very likely many of them do not recognize the parts of the Dandelion flower as looking anything like the parts of the flower with which they are familiar.

Before proceeding further, therefore let us take a Morning-Glory flower—which you all know and can easily obtain, or at least some flower like it—and let us see that the parts of the two correspond. [104]

Commencing in the centre we find in both a pistil, consisting of an ovary at the base and a stigma at the top and a style between. In the Dandelion the stigma is split in halves, while in the morning-glory it is not split but has three little knobs. Around the pistil come the stamens in each case. Each stamen is composed of two parts: a slender stem (the filament) and a little sac at the end (the anther) which is filled with pollen dust. In both cases the filaments grow out of the sides of the corolla. But while in the Morning-Glory the anthers are entirely free from one another, in the Dandelion they are joined together by their sides and form a tube around the style. The corolla in both cases is all of one piece, but in the Dandelion it is as if the upper part of the corolla were split open one side and then made flat. Instead of a green calyx as in the Morning-Glory, the Dandelion has a number of delicate white bristles. And, finally, in the Morning-Glory both the calyx and corolla grow out from below the ovary, while in the Dandelion its calyx of bristles and its corolla issue from above the ovary. So after all, you will see that corresponding organs are in both, and the difference between the two flowers is not so great as one might think at first. [105]

Let the different parts of the Dandelion be examined now more minutely. First take some of the bristles and examine them with one quarter inch power. They are not perfectly smooth, but are more or less saw-like on the edge. With the same power look at other parts of the flower; notice the hairiness of the stigmas, the pollen grains coming out of the anthers (some grains may be found on the stigmas) also the roughness of the ovary and the delicate ribs or veins in the corolla. Examine one of the seed-like fruits with one and one half inch power. It is a ripened ovary. Compare the fruit with the ovary of a flower. The nutlet has become hard, rougher and more strongly ribbed. The narrowed upper part of the ovary has become much elongated and the pappus is spread out like an inverted umbrella.

Examine some bristles with one quarter inch power. They show the saw-like edges much more developed than in the younger bristles of the flower. We see throughout a beautiful adaptation of every part for fitting the little parachute to be carried long distances by the wind and finally to catch on some suitable place in which to sprout. [106]

XIV.—HOW TO SEE A BUMBLE BEE. [107]

You will first need to catch your Bumble Bee. A little chloroform poured on one will kill it instantly. Make a general examination at the outset of the insect. The outside of the body is horny and covered thickly with hairs. On the upper side the hairs are much more numerous than on the under side. The whole body is divided into three regions: the head, bearing the feelers and mouth-parts; a middle part (thorax) bearing the four wings and six legs; and a hind part (abdomen) armed with the sting.

Remove the head and examine with one and one half inch power. At the sides are two prominent oval bodies (compound eyes) which seem to be crossed by five lines; near the top of the head, between the compound eyes, are three little shiny bead-like organs (simple eyes); starting from about the middle of the face are the two feelers (antennæ) and at the lower part of the head are the mouth-parts. The sides, top and front of the head are all covered with hair. [108]

Examine one of the compound eyes with one fourth inch power. The surface is made up of innumerable little facets, something like a cut diamond.

Cut off a piece of one of the compound eyes, remove some of the black pigment on the back and examine the piece in a drop of water. Each facet is a tiny hexagon. Some care is necessary to see them well.

Remove an antenna and examine it with three fourths inch power. It is thickly covered with minute hairs which give it a velvety appearance. Count the joints. At the base is the longest joint; at the lower end of which is a little knob that fits into a socket in the head. The next joint is quite

small while those beyond are much alike.

Scrape the hairs from the face and examine the horny shell with three fourths inch power. The surface is full of little pits. In the upper part of the face there is a groove, in the middle of which is one of the simple eyes. Just below the antennæ sockets is a groove which extends crosswise a short distance on either side and then bends downwards to the mouth. The portion of the face bounded by this groove is called the clypeus. At its lower part is hinged a little oblong piece (labium) which may be moved up and down with a needle. [109]

Melt a piece of sealing wax on the centre of a slip of glass (taking care not to break the glass by too sudden heating) and before the wax hardens press the head into it face downwards.

Examine with one inch power. The hole near the top of the head shows the position of the neck. The portion of the head around this hole is destitute of hairs and is hollowed in, to make room for the rounded front part of the thorax. Below this one there is another cavity which contains a portion of the mouth parts when they are retracted. At each side of the mouth in front of the base of the sucking organs, are the two jaws (mandibles) each with a little tuft of hair on the outer side. The jaws move freely to and from each other, sideways instead of up and down as do the jaws of the higher animals. The sucking apparatus consists of five pieces viz: two outermost pieces each tapering to a fine point, two, each of which ends in three little joints and one in the centre which projects beyond the others. It may be necessary to spread these out with the needle, to see them well. [110]

Separate the thorax from the rest of the body. Scrape off the hairs on the back. Two principal grooves extend across the back, one near the front and one near the hind margin. The thorax is composed of three divisions and these grooves show where they are joined together. The hind division bears the hind wings and the hind pair of legs; the middle division, much the largest division of the three, bears the fore wings and the middle pair of legs; and the foremost division is quite small and bears only the front pair of legs.

Remove the wings of one side and examine in a drop of water with one and one half inch power. The wings consist of a shining transparent membrane strengthened by numerous horny veins running through it. Examine with one half inch power. The membrane is seen to be covered with minute hairs and little dots. On the front edge of the hind wing a short distance from the outer end is a row of hooks. At a corresponding place on the hind edge of the fore wing there is a thickening or ridge. When flying, the hooks catch onto the ridge and thus the wings are held together and act as one large wing. [111]

Examine this grappling apparatus with one fourth inch power and with the needles hook the wings together and pull them apart. If you look through the magnifier while you do this you will get a good idea of the form of the ridge and of how the hooks catch onto it. Remove one of the forelegs, being sure that none remains attached to the body. Examine with one and one half inch power. The extremity is armed with two claws; then come four short joints followed by one about as long as the others together. All these make up the foot. The next joint above is the shank, then comes the thigh and then quite a small joint, the lower hip, and lastly attached to the body is the upper hip.

Remove the last five joints of the foot (the claw part, and the other four joints) examine with one third inch power. The claws have each a branch projecting from the inner edge. Between the claws is a little velvety pad. Each of the small joints is covered with short closely appressed hairs and from the lower end of each joint project several spines. Now examine the remaining long joint of the foot attached to the shank. At the upper end of the inner side is a deep semicircular notch, the upper portion of which is light colored. Beside the notch is a peculiarly shaped movable spine which projects from the lower end of the shank. This queer arrangement is what the bee uses to clean his feelers. The reader has probably seen the operation performed by a bee or a wasp. The leg is thrown over the feeler, the latter is grasped at that particular bend of the leg where the cleansing apparatus is situated and then drawn through from base to tip; and this is repeated several times with each feeler. [112]

Examine with one and one half inch power a leg from each of the other pairs and compare the corresponding parts. They differ chiefly in size and in the absence of the cleansing apparatus. You cannot fail to admire the many beautiful forms of the different portions. On the outer side of the hind shank is a smooth flattish surface destitute of hairs, excepting a fringe of long ones at the margin. At this place may sometimes be found a sticky mass of pollen intended for bee-bread. Examine the abdomen with one and one half inch power. It is composed of several wings. If some of the hairs are scraped off this will be shown more clearly. From the hind extremity projects the sting. [113]

We have far from exhausted all the beautiful and interesting points in the make-up of a Bumble Bee, not even those that may be seen with the limited powers of a simple microscope; but probably enough has been said to show the reader that such things are well worthy of study and it is hoped that enough directions have been given to render future use of the instruments comparatively free from difficulty.

XV.—SOME LITTLE THINGS TO SEE.

There is no end to the beautiful and wonderful things one can see with the simple microscope. [114]

Only a few of the more attractive and easily obtained of these are now to be mentioned.

To begin with, there are ever so many pretty flowers to look at. The asterworts, that is, such flowers as the daisy, aster, golden rod, dandelion and thistle, are particularly full of beauty. The blossoms are all made up of a number of little flowers as in the dandelion; but the shapes and colors and so forth, of the different kinds are exceedingly various. Some, such as the asters and daisies, have two kinds of flowers in the same blossom—flowers with strap-shaped corollas (like the dandelion's) are arranged along the margin of the blossom, while in the centre are little flowers with star-shaped corollas presenting a much different appearance. Flowers of many of the Parsley Family, for example wild carrot, wild parsnip and caraway, are quite odd. Very pretty flowers are found among the grasses, sedges and common weeds. The different trees as they bloom in spring—the maples, elms, willows, poplars, sassafras and hosts of others—all have flowers that are perfectly lovely. Most of these flowers need to be picked to pieces under the magnifier to show up their full beauty. The parts of flowers, both small and large ones, deserve attention. Frequently one meets with remarkable forms. [115]

Seeds are highly interesting. They are often handsomely marked with series of pits or projections, grooves or ridges. One meets with many curious appendages by means of which the seeds are carried off and sown at a distance from the plant. Some, like the dandelion, have a parachute attachment; others have wings to catch the wind, and others still are covered with hooked spines whereby they become attached to the fur of animals, there to remain until brushed off onto the ground.

Leaves and stems sometimes have on them beautiful hairs and oil-glands. The wooly covering of common mullein, for example, is made up of innumerable slender-branched hairs. These show best when a piece of the leaf broken off is looked at edgewise. [116]

If you examine the fruit-dots on the backs of the different kinds of ferns you will be surprised to find how pretty they are and of how many different shapes. Sometimes the fruit is not borne on the back of the leaf but forms little clusters by themselves, which are sometimes at the end of the fern, sometimes in the middle, sometimes on a separate stalk.

Mosses, lichens and sea-weeds are well worth looking at.

Early in the summer an exquisite little fungus called "Cluster cups" may be found on the underside of barberry leaves. Hawthorn and other plants have handsome fungi on them later in the season.

By observing closely while out in the fields or woods, one sees hovering about in swarms, myriads of tiny insects. Under the lens some of them are very odd, others very beautiful. The easiest way to catch these little midgets, is to wet the palm of the hand and then sweep it among them, or in the same way use a piece of sticky paper. [117]

The study of the different parts of insects is one of the most fascinating of the many uses of the Simple microscope. Although all insects are made up on the same general plan and corresponding organs occur in most of them, there is an endless variety in the forms under which we see the different organs and the uses to which they are put.

Take for example the antennæ. In the grasshopper it is long and threadlike; in the butterflies always ending in a knob; in moths always tapering to a point, although sometimes threadlike and sometimes much branched, forming a beautiful plume; in the beetles, sometimes fan-like, sometimes like a comb; and in other insects assuming still other forms. Insects' eyes are often colored beautifully. A horse-fly's eyes are striped. Butterflies' eyes have usually a soft liquid coloring, and moths' eyes in the dark shine like little fiery beads.

The mouths of insects, such as beetles, grasshoppers and dragon flies, have strong jaws for biting; flies, bugs, moths and butterflies, have the mouth-parts transformed into sucking organs, while bees, wasps and the like have both sucking organs for honey, and biting organs for leaf-cutting, wood-tearing etc. as we saw was the case in the Bumble Bee. [118]

Butterflies' wings and moths' wings are covered with little scales of a variety of shapes. These should be examined attached to the wing to show their arrangement which is like that of shingles on a roof; but to show their form they should be looked at when brushed from the wing onto a piece of glass. Many other peculiarities may be noticed in the wings of other kinds of insects.

Legs, the same as the other organs, have various forms, markings and appendages, and so it is with the abdomen and its stings or its egg-laying apparatus.

The hairs of "Wooly Bears" and caterpillars of that kind are peculiarly branched.

The four hind pairs of feet in caterpillars are armed each with a row of little hooks which are used in walking to get a firm hold. The larger caterpillars show the hooks best. [119]

Sometimes you will find pretty insect eggs on the underside of leaves or on stems, and also little silken cocoons in similar places. If you are near a pond-hole, or an old hogshead that collects rain water, you can find a good many little animals, some of them very frisky—young mosquitoes or "polywogs," water-fleas, cyclops, little worms, young dragon-flies and lots of others. When you go to collect them take a small wide-mouth bottle and, having found a place where there is what you want, lower your bottle, mouth down, in the midst of them and when it is well under water turn the mouth upwards. A good many of the animals will run in with the water. If the first time you do

not get what you want, the second time you may. When you want to examine them at home you can fish them out with a glass tube and put them in a watch crystal or on the glass stage of the microscope. In using the tube take it between the thumb and middle and third fingers, and close the top with your first finger; then put the lower end of the tube in the water close to the thing you want to catch; now lift your first finger quickly and the water will run in the lower end of the tube carrying with it your little squirmer, unless he has been too quick for you. Close the top of your tube again and the water will not run out when you remove the tube, until you lift your finger. Sometimes it takes a good deal of patience and skill to catch the more agile of the little water animals. Glass tubes are sold in drug stores for five or ten cents. [120]

If you begin by examining the objects already spoken of, you will while looking for these be continually discovering for yourselves new objects possessing new beauties and will soon see that not half the interesting things you can find have been ever hinted at.

The way to find out about all these things is to go out into the fields and woods, and form the habit of observing closely what is around you. Carry your magnifier along and look at this flower, that fern, this insect, that moss, with different powers of the magnifier; and when you come across any objects worthy of a more careful examination carry them home and examine them systematically with Simple microscope, needles, knife, and so forth. Insects may be kept well in alcohol until winter, and then careful studies may be made of them. [121]

When using the magnifier in the field, hold it in such a way that the smallest lens will be nearest the object when the lenses are combined and be careful not to shade the object with the hand or the hat brim. Just enough light should fall on the object to make its examination comfortable for the eyes. If you rest the hand holding the magnifier on the hand that holds the object, both lens and object can be held much steadier. When commencing to examine an object it is best to have the three lenses spread apart, for in this way you can use first the lowest power then those higher and finally, if you wish to, the three lenses combined. The dissecting forceps are very handy to have in the field, both for picking up anything too small for the fingers and for holding an object to be examined.

A collection of some of these little things preserved and ready for examination adds greatly to the pleasures of studying them. Of course all the different kinds of objects cannot be preserved so as to show their full beauty, but many can be and the following directions will tell how to make a very good collection: [122]

Seeds, fern-fruit, insects and other opaque objects like these may be mounted on pasteboard slides. One of these slides consists simply of a stout piece of pasteboard, having a hole cut in the centre and a piece of thick paper or cardboard glued on the under side. The object is attached to the cardboard at the bottom of the hole.

It is best to make a number of these slides at a time. Having procured some quite thick pasteboard, from old paper boxes, rule lines on the surface dividing it up into spaces three inches long by one inch wide. In the centre of each space cut out a hole about half an inch in diameter. A sharp knife will make a neat square hole or a good round one may be made with a gun-wad punch. This done, the spaces may be cut apart with a sharp knife and ruler, along the lines already drawn. Pieces of cardboard for the backs should be cut a trifle larger than the pasteboard portion of the slide; after they are glued onto the latter they may be trimmed down neatly with a pair of scissors. Glue or mucilage containing glycerine (in the proportion of one or two teaspoonfuls to an ordinary bottle of mucilage) is the best thing to use for sticking on the backs. While the slides are drying they should be either under a weight or in a clamp screwed up tightly, so as to prevent their twisting out of shape. The mucilage may be prevented from being squeezed in round the edges of the hole, by taking care when putting it on not to have it come too near the hole. One or two coats of India Ink may be painted on the middle of some of the pieces of cardboard, either before or after they are put onto the slides; and thus a black background may be obtained for the lighter-colored opaque objects. Many of the objects will however show best on a white background. [123]

When you have the slides all made, nothing more is needed to mount an object, than simply to attach it to the bottom of the hole with a little mucilage and glycerine, or something of that sort, and finally to write the name of the object on the front part of the slide, and on the back any desirable notes. A good way to mount such objects as fine seeds is to put them in the hole loosely and then cover them with a piece of mica such as will be spoken of presently. [124]

Objects which are to be examined by the light shining through them, for example a bee's wing or a butterfly's scales, must be mounted on glass slides.

A glass slide three inches by one is taken, on the centre is placed the object; over this is laid a thin piece of clear mica three fourths of an inch square, and this is attached to the glass by pasting narrow strips of tissue paper around the edges of the cover, partly on the cover and partly on the slide. Finally the slide is covered with some pretty colored paper and labeled.

Two pieces of paper are needed to cover each slide. One for the under part is cut about one and one half by three and one half inches, with a hole in the centre (round or square). This piece is first pasted on, the corners being cut and the edges brought over onto the front. The upper piece, which has a hole in the centre similar to that in the lower piece, and is cut a trifle larger than the three by one inch slide, is next pasted on so that the hole will correspond with the one below. The upper piece of paper is now trimmed down to the slide and the label attached. Window glass will [125]

answer for the slides and you can get any glazier to cut up a piece for you into the right-sized slips. Mica can be bought at a stove store, in sheets which may be cut up into three fourths of an inch squares with a pair of scissors. The mica should be as clear as you can get it. You will find it handy to have some tissue paper all muddled like postage stamps and cut up in strips the right size ready to use. The same may be said of the colored paper covers and the labels.

The dust may be excluded from the uncovered opaque objects by keeping the mounted slides in small groups, held together by elastic bands. This will also serve to classify them so that all the insects will be together, all the seeds, and so on; and the transparent slides may also be treated in the same way. When an elastic band wears out, it is no great trouble to replace it. [126]

In working with the Simple microscope there is a fine chance to display ingenuity, not only in making the instruments and mounting the objects but in discovering new things to look at and in seeing how much can be found out about those things which are the most common.

FOOTNOTE:

- [A] In these directions " $1\frac{1}{2}$ in. power" means a lens having a focus of $1\frac{1}{2}$ inches; " $\frac{1}{2}$ in. power" means a lens or combination of lenses having a focus of $\frac{1}{2}$ inch; and so on. All the different powers mentioned in the directions may be obtained in the small-sized 3-lens, bellows form magnifier, either by using the lenses singly or combined in different ways. The magnifying power of any single lens or simple combination is easily found by dividing 10, by the focus in inches. Thus the magnifying power of a $\frac{1}{2}$ in. lens is found in this way: $10 \div \frac{1}{2} = 10 \times 2 = 20$. The lens magnifies therefore 20 diameters *i. e.* makes an object appear twenty times as long and twenty times as broad as it is.

TRANSCRIBER'S NOTES:

Inconsistencies in hyphenation have been retained from the original.

Obvious typographical errors have been corrected as follows:

- Page 8: hundreth changed to hundredth
- Page 11: iustrument changed to instrument
- Page 15: diferent changed to different
- Page 17: he changed to the
- Page 20: wil changed to will
- Page 44: or changed to of
- Page 72: staightened changed to straightened
- Page 86: DIFFRENT changed to DIFFERENT
- Page 125: fouths changed to fourths

*** END OF THE PROJECT GUTENBERG EBOOK THROUGH A MICROSCOPE ***

Updated editions will replace the previous one—the old editions will be renamed.

Creating the works from print editions not protected by U.S. copyright law means that no one owns a United States copyright in these works, so the Foundation (and you!) can copy and distribute it in the United States without permission and without paying copyright royalties. Special rules, set forth in the General Terms of Use part of this license, apply to copying and distributing Project Gutenberg™ electronic works to protect the PROJECT GUTENBERG™ concept and trademark. Project Gutenberg is a registered trademark, and may not be used if you charge for an eBook, except by following the terms of the trademark license, including paying royalties for use of the Project Gutenberg trademark. If you do not charge anything for copies of this eBook, complying with the trademark license is very easy. You may use this eBook for nearly any purpose such as creation of derivative works, reports, performances and research. Project Gutenberg eBooks may be modified and printed and given away—you may do practically ANYTHING in the United States with eBooks not protected by U.S. copyright law. Redistribution is subject to the trademark license, especially commercial redistribution.

START: FULL LICENSE
THE FULL PROJECT GUTENBERG LICENSE
PLEASE READ THIS BEFORE YOU DISTRIBUTE OR USE THIS WORK

To protect the Project Gutenberg™ mission of promoting the free distribution of electronic works, by using or distributing this work (or any other work associated in any way with the phrase "Project Gutenberg"), you agree to comply with all the terms of the Full Project Gutenberg™ License available with this file or online at www.gutenberg.org/license.

Section 1. General Terms of Use and Redistributing Project Gutenberg™ electronic works

1.A. By reading or using any part of this Project Gutenberg™ electronic work, you indicate that you have read, understand, agree to and accept all the terms of this license and intellectual property (trademark/copyright) agreement. If you do not agree to abide by all the terms of this agreement, you must cease using and return or destroy all copies of Project Gutenberg™ electronic works in your possession. If you paid a fee for obtaining a copy of or access to a Project Gutenberg™ electronic work and you do not agree to be bound by the terms of this agreement, you may obtain a refund from the person or entity to whom you paid the fee as set forth in paragraph 1.E.8.

1.B. “Project Gutenberg” is a registered trademark. It may only be used on or associated in any way with an electronic work by people who agree to be bound by the terms of this agreement. There are a few things that you can do with most Project Gutenberg™ electronic works even without complying with the full terms of this agreement. See paragraph 1.C below. There are a lot of things you can do with Project Gutenberg™ electronic works if you follow the terms of this agreement and help preserve free future access to Project Gutenberg™ electronic works. See paragraph 1.E below.

1.C. The Project Gutenberg Literary Archive Foundation (“the Foundation” or PGLAF), owns a compilation copyright in the collection of Project Gutenberg™ electronic works. Nearly all the individual works in the collection are in the public domain in the United States. If an individual work is unprotected by copyright law in the United States and you are located in the United States, we do not claim a right to prevent you from copying, distributing, performing, displaying or creating derivative works based on the work as long as all references to Project Gutenberg are removed. Of course, we hope that you will support the Project Gutenberg™ mission of promoting free access to electronic works by freely sharing Project Gutenberg™ works in compliance with the terms of this agreement for keeping the Project Gutenberg™ name associated with the work. You can easily comply with the terms of this agreement by keeping this work in the same format with its attached full Project Gutenberg™ License when you share it without charge with others.

1.D. The copyright laws of the place where you are located also govern what you can do with this work. Copyright laws in most countries are in a constant state of change. If you are outside the United States, check the laws of your country in addition to the terms of this agreement before downloading, copying, displaying, performing, distributing or creating derivative works based on this work or any other Project Gutenberg™ work. The Foundation makes no representations concerning the copyright status of any work in any country other than the United States.

1.E. Unless you have removed all references to Project Gutenberg:

1.E.1. The following sentence, with active links to, or other immediate access to, the full Project Gutenberg™ License must appear prominently whenever any copy of a Project Gutenberg™ work (any work on which the phrase “Project Gutenberg” appears, or with which the phrase “Project Gutenberg” is associated) is accessed, displayed, performed, viewed, copied or distributed:

This eBook is for the use of anyone anywhere in the United States and most other parts of the world at no cost and with almost no restrictions whatsoever. You may copy it, give it away or re-use it under the terms of the Project Gutenberg License included with this eBook or online at www.gutenberg.org. If you are not located in the United States, you will have to check the laws of the country where you are located before using this eBook.

1.E.2. If an individual Project Gutenberg™ electronic work is derived from texts not protected by U.S. copyright law (does not contain a notice indicating that it is posted with permission of the copyright holder), the work can be copied and distributed to anyone in the United States without paying any fees or charges. If you are redistributing or providing access to a work with the phrase “Project Gutenberg” associated with or appearing on the work, you must comply either with the requirements of paragraphs 1.E.1 through 1.E.7 or obtain permission for the use of the work and the Project Gutenberg™ trademark as set forth in paragraphs 1.E.8 or 1.E.9.

1.E.3. If an individual Project Gutenberg™ electronic work is posted with the permission of the copyright holder, your use and distribution must comply with both paragraphs 1.E.1 through 1.E.7 and any additional terms imposed by the copyright holder. Additional terms will be linked to the Project Gutenberg™ License for all works posted with the permission of the copyright holder found at the beginning of this work.

1.E.4. Do not unlink or detach or remove the full Project Gutenberg™ License terms from this work, or any files containing a part of this work or any other work associated with Project Gutenberg™.

1.E.5. Do not copy, display, perform, distribute or redistribute this electronic work, or any

part of this electronic work, without prominently displaying the sentence set forth in paragraph 1.E.1 with active links or immediate access to the full terms of the Project Gutenberg™ License.

1.E.6. You may convert to and distribute this work in any binary, compressed, marked up, nonproprietary or proprietary form, including any word processing or hypertext form. However, if you provide access to or distribute copies of a Project Gutenberg™ work in a format other than “Plain Vanilla ASCII” or other format used in the official version posted on the official Project Gutenberg™ website (www.gutenberg.org), you must, at no additional cost, fee or expense to the user, provide a copy, a means of exporting a copy, or a means of obtaining a copy upon request, of the work in its original “Plain Vanilla ASCII” or other form. Any alternate format must include the full Project Gutenberg™ License as specified in paragraph 1.E.1.

1.E.7. Do not charge a fee for access to, viewing, displaying, performing, copying or distributing any Project Gutenberg™ works unless you comply with paragraph 1.E.8 or 1.E.9.

1.E.8. You may charge a reasonable fee for copies of or providing access to or distributing Project Gutenberg™ electronic works provided that:

- You pay a royalty fee of 20% of the gross profits you derive from the use of Project Gutenberg™ works calculated using the method you already use to calculate your applicable taxes. The fee is owed to the owner of the Project Gutenberg™ trademark, but he has agreed to donate royalties under this paragraph to the Project Gutenberg Literary Archive Foundation. Royalty payments must be paid within 60 days following each date on which you prepare (or are legally required to prepare) your periodic tax returns. Royalty payments should be clearly marked as such and sent to the Project Gutenberg Literary Archive Foundation at the address specified in Section 4, “Information about donations to the Project Gutenberg Literary Archive Foundation.”
- You provide a full refund of any money paid by a user who notifies you in writing (or by e-mail) within 30 days of receipt that s/he does not agree to the terms of the full Project Gutenberg™ License. You must require such a user to return or destroy all copies of the works possessed in a physical medium and discontinue all use of and all access to other copies of Project Gutenberg™ works.
- You provide, in accordance with paragraph 1.F.3, a full refund of any money paid for a work or a replacement copy, if a defect in the electronic work is discovered and reported to you within 90 days of receipt of the work.
- You comply with all other terms of this agreement for free distribution of Project Gutenberg™ works.

1.E.9. If you wish to charge a fee or distribute a Project Gutenberg™ electronic work or group of works on different terms than are set forth in this agreement, you must obtain permission in writing from the Project Gutenberg Literary Archive Foundation, the manager of the Project Gutenberg™ trademark. Contact the Foundation as set forth in Section 3 below.

1.F.

1.F.1. Project Gutenberg volunteers and employees expend considerable effort to identify, do copyright research on, transcribe and proofread works not protected by U.S. copyright law in creating the Project Gutenberg™ collection. Despite these efforts, Project Gutenberg™ electronic works, and the medium on which they may be stored, may contain “Defects,” such as, but not limited to, incomplete, inaccurate or corrupt data, transcription errors, a copyright or other intellectual property infringement, a defective or damaged disk or other medium, a computer virus, or computer codes that damage or cannot be read by your equipment.

1.F.2. LIMITED WARRANTY, DISCLAIMER OF DAMAGES - Except for the “Right of Replacement or Refund” described in paragraph 1.F.3, the Project Gutenberg Literary Archive Foundation, the owner of the Project Gutenberg™ trademark, and any other party distributing a Project Gutenberg™ electronic work under this agreement, disclaim all liability to you for damages, costs and expenses, including legal fees. YOU AGREE THAT YOU HAVE NO REMEDIES FOR NEGLIGENCE, STRICT LIABILITY, BREACH OF WARRANTY OR BREACH OF CONTRACT EXCEPT THOSE PROVIDED IN PARAGRAPH 1.F.3. YOU AGREE THAT THE FOUNDATION, THE TRADEMARK OWNER, AND ANY DISTRIBUTOR UNDER THIS AGREEMENT WILL NOT BE LIABLE TO YOU FOR ACTUAL, DIRECT, INDIRECT, CONSEQUENTIAL, PUNITIVE OR INCIDENTAL DAMAGES EVEN IF YOU GIVE NOTICE OF THE POSSIBILITY OF SUCH DAMAGE.

1.F.3. LIMITED RIGHT OF REPLACEMENT OR REFUND - If you discover a defect in this electronic work within 90 days of receiving it, you can receive a refund of the money (if any) you paid for it by sending a written explanation to the person you received the work from. If you received the work on a physical medium, you must return the medium with your written

explanation. The person or entity that provided you with the defective work may elect to provide a replacement copy in lieu of a refund. If you received the work electronically, the person or entity providing it to you may choose to give you a second opportunity to receive the work electronically in lieu of a refund. If the second copy is also defective, you may demand a refund in writing without further opportunities to fix the problem.

1.F.4. Except for the limited right of replacement or refund set forth in paragraph 1.F.3, this work is provided to you 'AS-IS', WITH NO OTHER WARRANTIES OF ANY KIND, EXPRESS OR IMPLIED, INCLUDING BUT NOT LIMITED TO WARRANTIES OF MERCHANTABILITY OR FITNESS FOR ANY PURPOSE.

1.F.5. Some states do not allow disclaimers of certain implied warranties or the exclusion or limitation of certain types of damages. If any disclaimer or limitation set forth in this agreement violates the law of the state applicable to this agreement, the agreement shall be interpreted to make the maximum disclaimer or limitation permitted by the applicable state law. The invalidity or unenforceability of any provision of this agreement shall not void the remaining provisions.

1.F.6. INDEMNITY - You agree to indemnify and hold the Foundation, the trademark owner, any agent or employee of the Foundation, anyone providing copies of Project Gutenberg™ electronic works in accordance with this agreement, and any volunteers associated with the production, promotion and distribution of Project Gutenberg™ electronic works, harmless from all liability, costs and expenses, including legal fees, that arise directly or indirectly from any of the following which you do or cause to occur: (a) distribution of this or any Project Gutenberg™ work, (b) alteration, modification, or additions or deletions to any Project Gutenberg™ work, and (c) any Defect you cause.

Section 2. Information about the Mission of Project Gutenberg™

Project Gutenberg™ is synonymous with the free distribution of electronic works in formats readable by the widest variety of computers including obsolete, old, middle-aged and new computers. It exists because of the efforts of hundreds of volunteers and donations from people in all walks of life.

Volunteers and financial support to provide volunteers with the assistance they need are critical to reaching Project Gutenberg™'s goals and ensuring that the Project Gutenberg™ collection will remain freely available for generations to come. In 2001, the Project Gutenberg Literary Archive Foundation was created to provide a secure and permanent future for Project Gutenberg™ and future generations. To learn more about the Project Gutenberg Literary Archive Foundation and how your efforts and donations can help, see Sections 3 and 4 and the Foundation information page at www.gutenberg.org.

Section 3. Information about the Project Gutenberg Literary Archive Foundation

The Project Gutenberg Literary Archive Foundation is a non-profit 501(c)(3) educational corporation organized under the laws of the state of Mississippi and granted tax exempt status by the Internal Revenue Service. The Foundation's EIN or federal tax identification number is 64-6221541. Contributions to the Project Gutenberg Literary Archive Foundation are tax deductible to the full extent permitted by U.S. federal laws and your state's laws.

The Foundation's business office is located at 809 North 1500 West, Salt Lake City, UT 84116, (801) 596-1887. Email contact links and up to date contact information can be found at the Foundation's website and official page at www.gutenberg.org/contact

Section 4. Information about Donations to the Project Gutenberg Literary Archive Foundation

Project Gutenberg™ depends upon and cannot survive without widespread public support and donations to carry out its mission of increasing the number of public domain and licensed works that can be freely distributed in machine-readable form accessible by the widest array of equipment including outdated equipment. Many small donations (\$1 to \$5,000) are particularly important to maintaining tax exempt status with the IRS.

The Foundation is committed to complying with the laws regulating charities and charitable donations in all 50 states of the United States. Compliance requirements are not uniform and it takes a considerable effort, much paperwork and many fees to meet and keep up with these requirements. We do not solicit donations in locations where we have not received written confirmation of compliance. To SEND DONATIONS or determine the status of compliance for any particular state visit www.gutenberg.org/donate.

While we cannot and do not solicit contributions from states where we have not met the solicitation requirements, we know of no prohibition against accepting unsolicited donations from donors in such states who approach us with offers to donate.

International donations are gratefully accepted, but we cannot make any statements concerning tax treatment of donations received from outside the United States. U.S. laws alone swamp our small staff.

Please check the Project Gutenberg web pages for current donation methods and addresses. Donations are accepted in a number of other ways including checks, online payments and credit card donations. To donate, please visit: www.gutenberg.org/donate

Section 5. General Information About Project Gutenberg™ electronic works

Professor Michael S. Hart was the originator of the Project Gutenberg™ concept of a library of electronic works that could be freely shared with anyone. For forty years, he produced and distributed Project Gutenberg™ eBooks with only a loose network of volunteer support.

Project Gutenberg™ eBooks are often created from several printed editions, all of which are confirmed as not protected by copyright in the U.S. unless a copyright notice is included. Thus, we do not necessarily keep eBooks in compliance with any particular paper edition.

Most people start at our website which has the main PG search facility: www.gutenberg.org.

This website includes information about Project Gutenberg™, including how to make donations to the Project Gutenberg Literary Archive Foundation, how to help produce our new eBooks, and how to subscribe to our email newsletter to hear about new eBooks.