

The Project Gutenberg eBook of A Complete List of the Books Included in the S. & C. Series of Elementary Manuals for Mechanics and Students published by E. & F. N. Spon, Ltd., London. January 1912, by E. & F. N. Spon

This ebook is for the use of anyone anywhere in the United States and most other parts of the world at no cost and with almost no restrictions whatsoever. You may copy it, give it away or re-use it under the terms of the Project Gutenberg License included with this ebook or online at www.gutenberg.org. If you are not located in the United States, you'll have to check the laws of the country where you are located before using this eBook.

Title: A Complete List of the Books Included in the S. & C. Series of Elementary Manuals for Mechanics and Students published by E. & F. N. Spon, Ltd., London. January 1912

Creator: E. & F. N. Spon

Release date: August 2, 2013 [EBook #43384]

Language: English

Credits: Produced by Chris Curnow, Diane Monico, and the Online Distributed Proofreading Team at <http://www.pgdp.net> (This file was produced from images generously made available by The Internet Archive)

*** START OF THE PROJECT GUTENBERG EBOOK A COMPLETE LIST OF THE BOOKS INCLUDED IN THE S. & C. SERIES OF ELEMENTARY MANUALS FOR MECHANICS AND STUDENTS PUBLISHED BY E. & F. N. SPON, LTD., LONDON. JANUARY 1912 ***

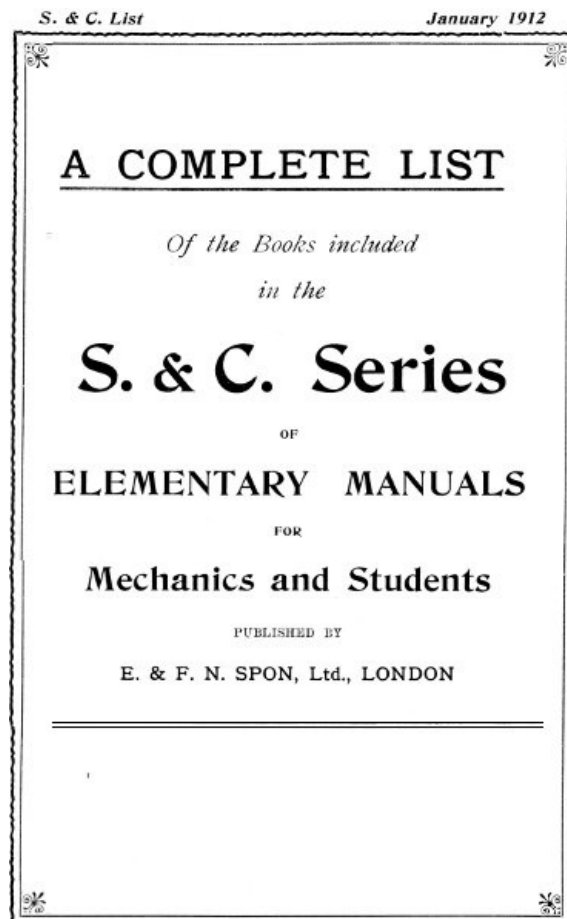

S. & C. List January 1912

A COMPLETE LIST

Of the Books included in the

S. & C. Series
OF
ELEMENTARY MANUALS
FOR
Mechanics and Students

PUBLISHED BY
E. & F. N. SPON, Ltd., LONDON

THE S. & C. SERIES

Uniform, in cloth, Price 1s. 6d. net each.

- [1. Modern Primary Batteries.](#) By N. H. SCHNEIDER.
- [2. How to Install Electric Bells, Annunciators and Alarms.](#) By N. H. SCHNEIDER.
- [3. Electrical Circuits and Diagrams, Part I.](#) By N. H. SCHNEIDER.
- [4. Electrical Circuits and Diagrams, Part II.](#) By N. H. SCHNEIDER.
- [5. Experimenting with Induction Coils.](#) By N. H. SCHNEIDER (*H. S. Norrie*).
- [6. The Study of Electricity for Beginners.](#) By N. H. SCHNEIDER.
- [7. Dry Batteries, how to make and Use them.](#) By A DRY BATTERY EXPERT.
- [8. Electric Gas Lighting.](#) By N. H. SCHNEIDER.
- [9. Model Steam Engine Design.](#) By R. M. DE VIGNIER.
- [10. Inventions, how to Protect, Sell and Buy Them.](#) By F. B. WRIGHT.
- [11. Making Wireless Outfits.](#) By N. HARRISON.
- [12. Wireless Telephone Construction.](#) By N. HARRISON.
- [13. Practical Electrics; a Universal Handy Book on Everyday Electrical Matters.](#)
- [14. How to Build a 20-foot Bi-plane Glider.](#) By A. P. MORGAN.
- [15. The Model Vaudeville Theatre.](#) By N. H. SCHNEIDER.
- [16. The Fireman's Guide; a Handbook on the Care of Boilers.](#) By K. P. DAHLSTROM.
- [17. A.B.C. of the Steam Engine, with a Description of the Automatic Governor.](#) By J. P. LISK.
- [18. Simple Soldering, both Hard and Soft.](#) By E. THATCHER.
- [19. Ignition Accumulators, their Care and Management.](#) By H. H. U. CROSS.
- [20. Key to Linear Perspective.](#) By C. W. DYMOND, F.S.A..
- [21. Elements of Telephony.](#) By ARTHUR CROTCH.
- [22. Experimental Study of the Gyroscope.](#) By V. E. JOHNSON, M.A..
- [23. The Corliss Engine.](#) By J. T. HENTHORN.
- [24. Wireless Telegraphy for Intending Operators.](#) By C. K. P. EDEN.
- [25. Wiring Houses for the Electric Light.](#) By N. H. SCHNEIDER.
- [26. Low Voltage Electric Lighting with the Storage Battery.](#) By N. H. SCHNEIDER.
- [27. Practical Silo Construction in Concrete.](#) By A. A. HOUGHTON.
- [28. Molding Concrete Chimneys, Slate and Roof Tiles.](#) By A. A. HOUGHTON.
- [29. Molding and Curing Ornamental Concrete.](#) By A. A. HOUGHTON.
- [30. Concrete Wall Forms.](#) By A. A. HOUGHTON.
- [31. Concrete Monuments, Mausoleums and Burial Vaults.](#) By A. A. HOUGHTON.
- [32. Concrete Floors and Sidewalks.](#) By A. A. HOUGHTON.
- [33. Molding Concrete Bath Tubs, Aquariums and Natatoriums.](#) By A. A. HOUGHTON.
- 34 to 38 inclusive. *Works on Concrete Structures, by A. A. Houghton, and now in the Press.*
- [39. Natural Stability and the Parachute Principle in Aeroplanes.](#) By W. LEMAITRE.
- [40. Builders' Quantities.](#) By H. M. LEWIS.

E. & F. N. SPON, Ltd., LONDON.

No. 1.—The S. & C. Series. Price 1/6 net.

MODERN PRIMARY BATTERIES.

THEIR CONSTRUCTION,
USE AND MAINTENANCE.

Including Batteries for Telephones, Telegraphs, Motors, Electric
Lights, Induction Coils, and for all
Experimental Work.

By

NORMAN H. SCHNEIDER.

55 Illustrations and 94 pages of Text.

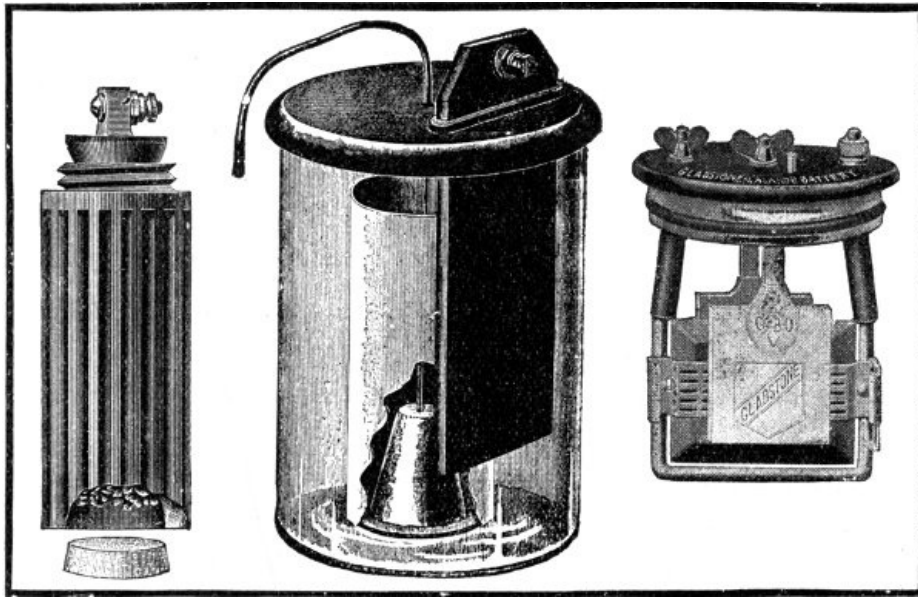

No. 2.—The S. & C. Series. Price 1/6 net.

HOW TO INSTALL ELECTRIC BELLS, ANNUNCIATORS, AND ALARMS.

INCLUDING

Batteries, Wires and Wiring, Circuits, Pushes, Bells, Burglar
Alarms, High and Low Water Alarms, Fire Alarms,
Thermostats, Annunciators, and the Location
and Remedying of Troubles.

By NORMAN H. SCHNEIDER.

59 Illustrations and 63 pages of Text.

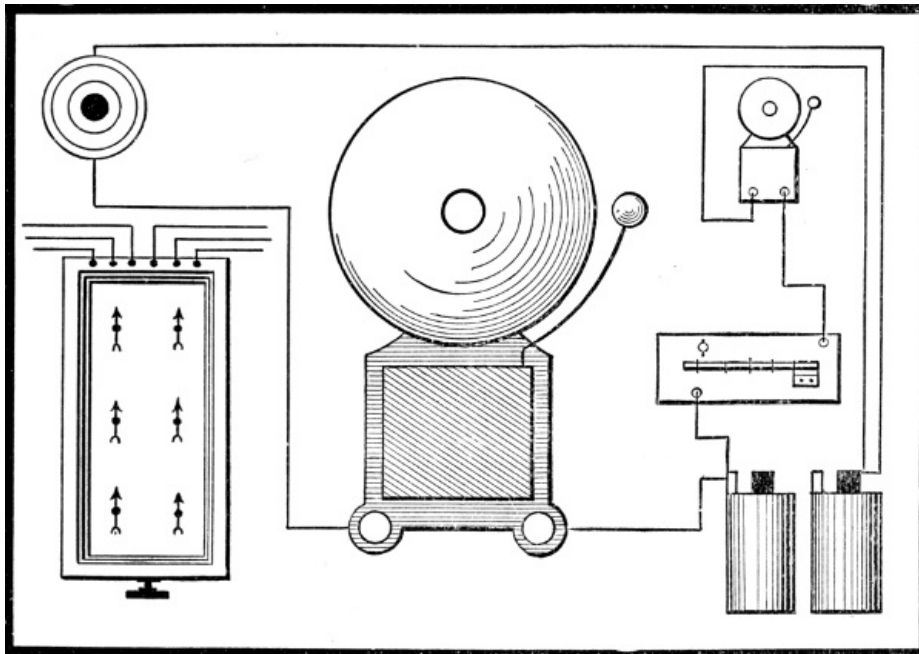

No. 3.—The S. & C. Series. Price 1/6 net.

ELECTRICAL CIRCUITS AND DIAGRAMS

ILLUSTRATED AND EXPLAINED.
PART I.

New and Original Drawings, comprising Alarms, Annunciators,
Automobiles, Bells, Dynamos, Gas Lighting, Motors,
Storage Batteries, Street Railways, Telephone,
Telegraph, Wireless Telegraphy,
Wiring and Testing.

BY

NORMAN H. SCHNEIDER.

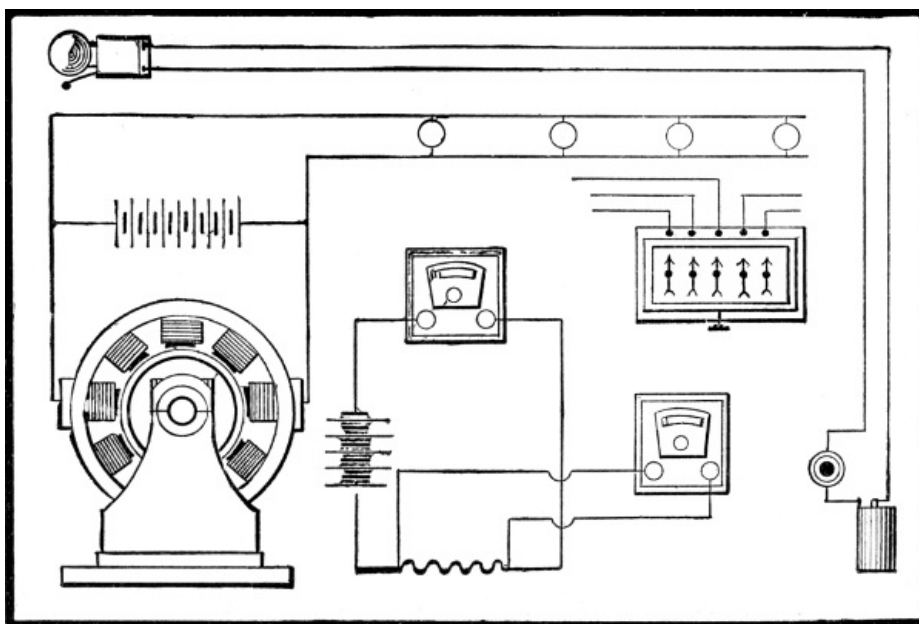

No. 4.—The S. & C. Series. Price 1/6 net.

Electrical Circuits and Diagrams

PART II.

Alternating Current Generators and Motors, Single Phase and Polyphase Transformers, Alternating Current and Direct Current Motor Starters and Reversers, Arc Generators and Circuits, Switches, Wiring, Storage Battery Meter Connections.

BY

NORMAN H. SCHNEIDER.

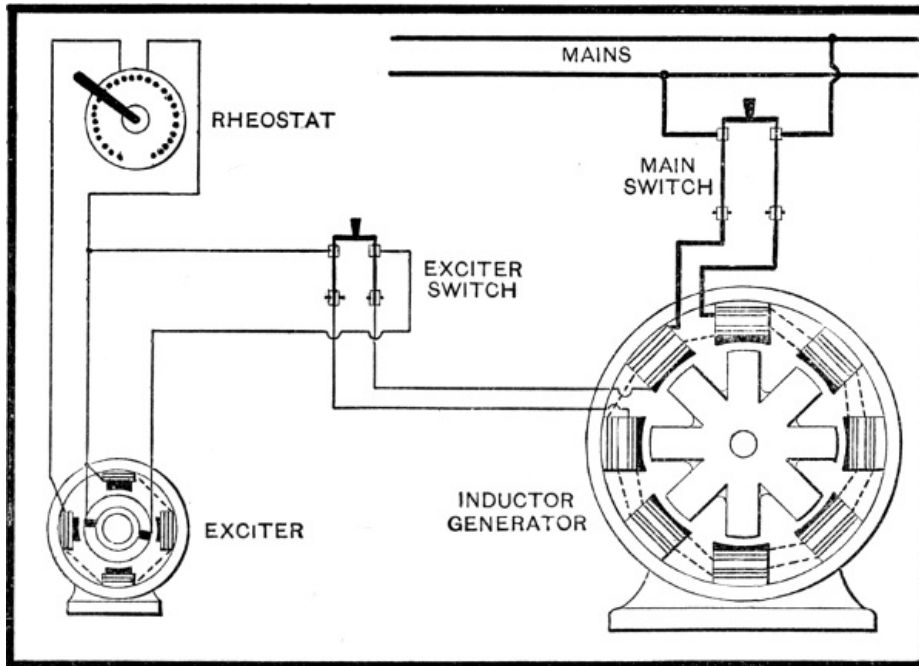

No. 5.—The S. & C. Series. Price 1/6 net.

EXPERIMENTING WITH INDUCTION COILS.

Containing practical directions for operating Induction Coils and Tesla Coils; also showing how to make the apparatus needed for the numerous experiments described.

BY

H. S. NORRIE,

Author of "Induction Coils and Coil Making."

26 Illustrations and 73 pages of Text.

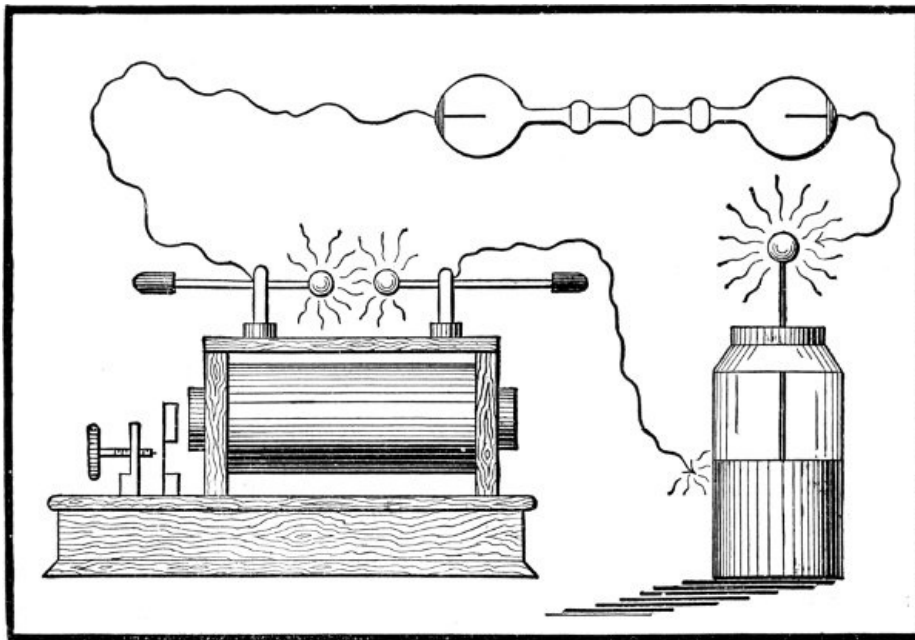

No. 6.—The S. & C. Series. Price 1/6 net.

**THE
STUDY OF ELECTRICITY
FOR BEGINNERS.**

Comprising the Elements of Electricity and Magnetism as Applied
to Dynamos, Motors, Wiring, and to all Branches
of Electrical Work.

BY

NORMAN H. SCHNEIDER.

With Fifty-four Original Illustrations and Six Tables.

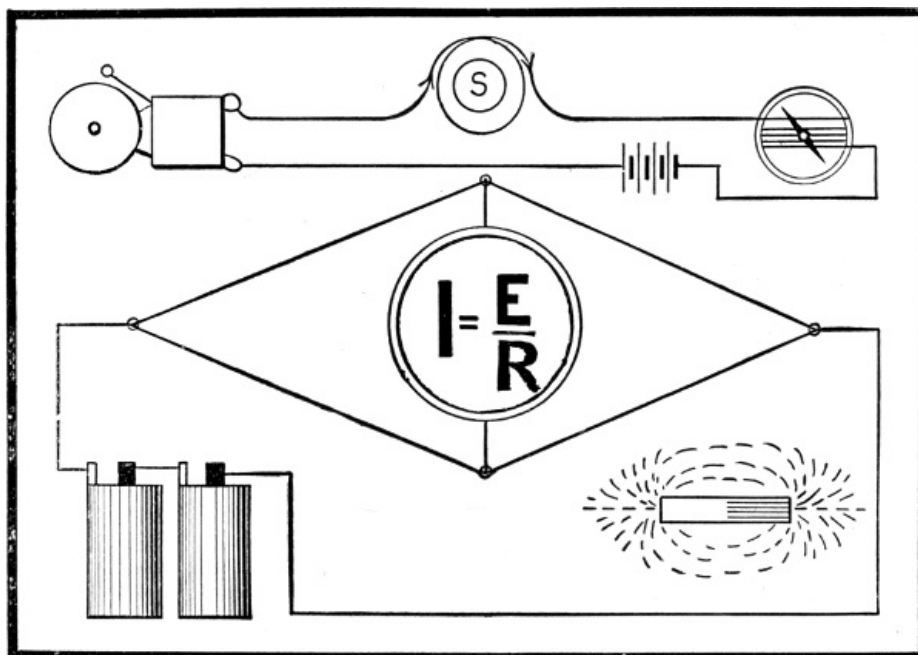

No. 7.—The S. & C. Series. Price 1/6 net.

DRY BATTERIES,

ESPECIALLY ADAPTED FOR

Automobile, Launch and Gas Engine Work; Medical Coils, Bells,
Annunciators, Burglar Alarms, Telephones, Electrical
Experiments and all purposes requiring
a Good Battery.

WITH THIRTY ORIGINAL ILLUSTRATIONS.

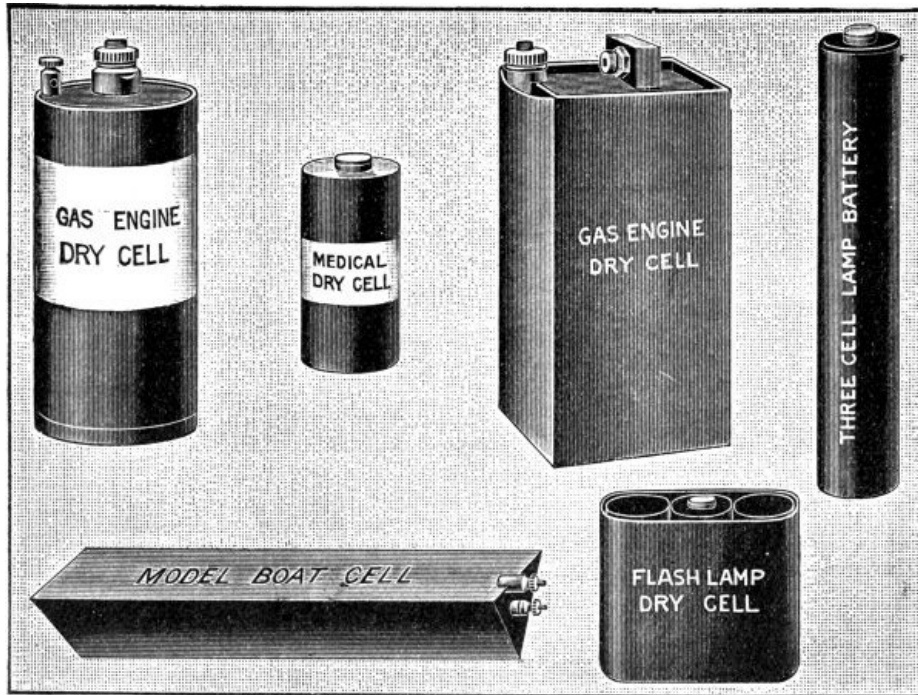

No. 8.—The S. & C. Series. Price 1/6 net.

**Electric Gas Igniting
APPARATUS**

How to Install Electric Gas Igniting Apparatus, including
the Jump Spark and Multiple Systems for all purposes,
with Suitable Batteries and Wiring,

BY

H. S. NORRIE.

Author of "Induction Coils and Coil Making."

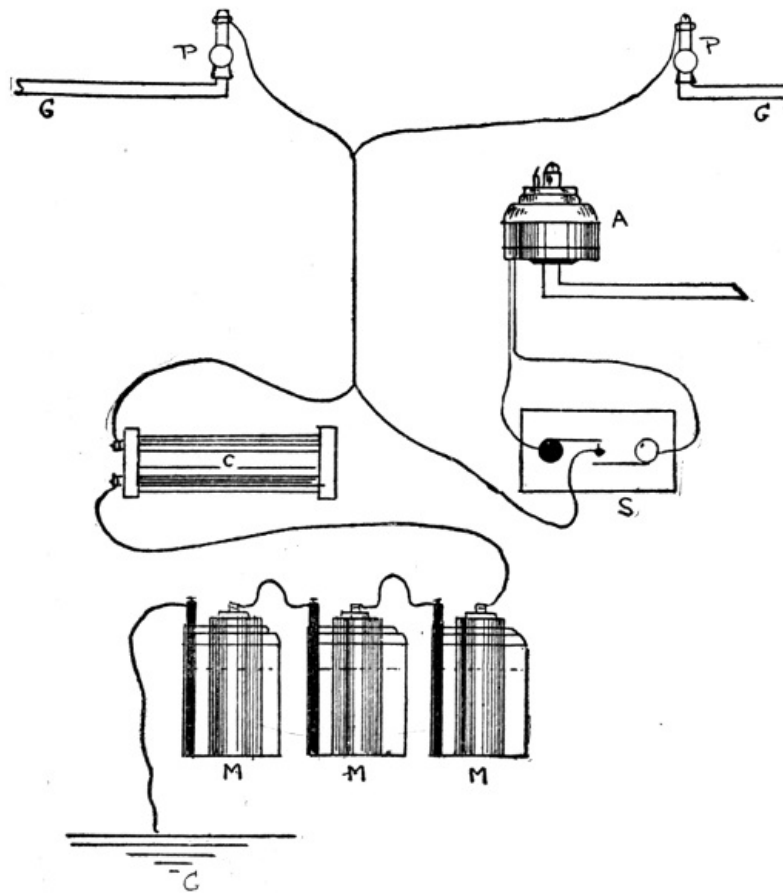

No. 9.—The S. & C. Series. Price 1/6 net.

MODEL STEAM ENGINE DESIGN

A HANDBOOK FOR THE DESIGNER OF SMALL STEAM ENGINES.

By R. M. DE VIGNIER.

Including original tables and
calculations for speed, power,
proportions of pumps, compound
engines and valve diagrams.

34 Illustrations and
94 pages of Text

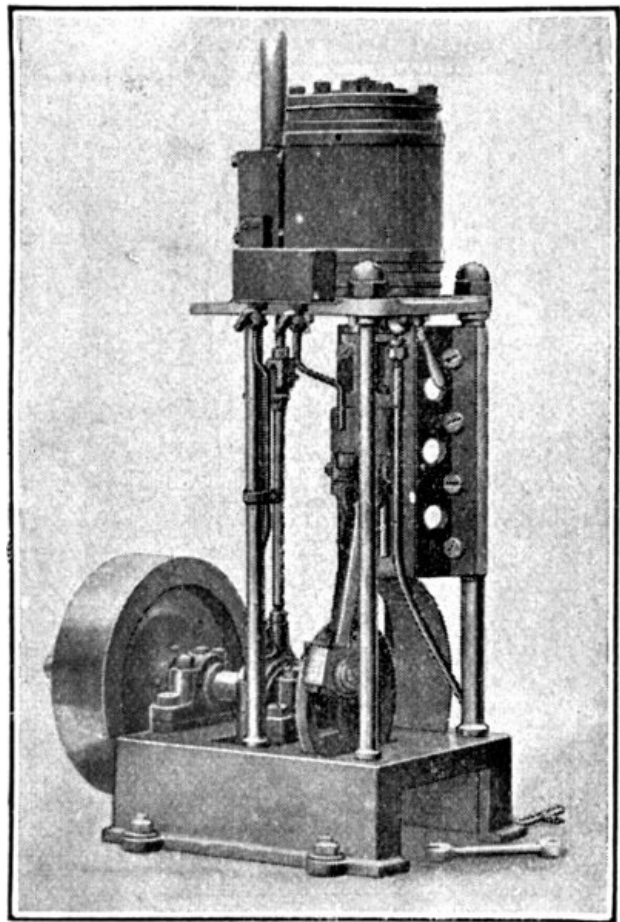

No. 10.—The S. & C. Series. Price 1/6 net.

INVENTIONS

How to Protect, Sell, and Buy Them

BY

F. B. WRIGHT

118 pages of Text

No. 11.—The S. & C. Series. Price 1/6 net.

Making Wireless Outfits

A CONCISE AND SIMPLE EXPLANATION ON THE
CONSTRUCTION AND USE OF
INEXPENSIVE WIRELESS EQUIPMENTS UP TO 100 MILES

By

NEWTON HARRISON, E. E.

With 27 Illustrations and 61 pages of Text

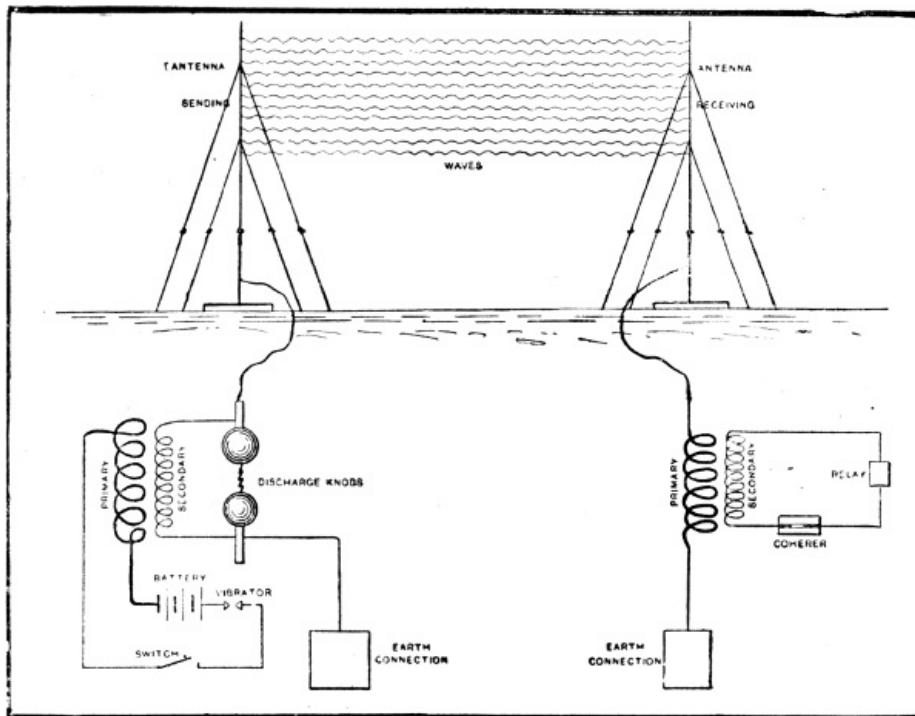

No. 12.—The S. & C. Series. Price 1/6 net.

Wireless Telephone Construction

A Comprehensive Explanation of the Making of a
Wireless Telephone Equipment for Receiving and Sending
Stations with Details of Construction

BY

NEWTON HARRISON, E. E.

With 43 Illustrations and 74 pages of Text

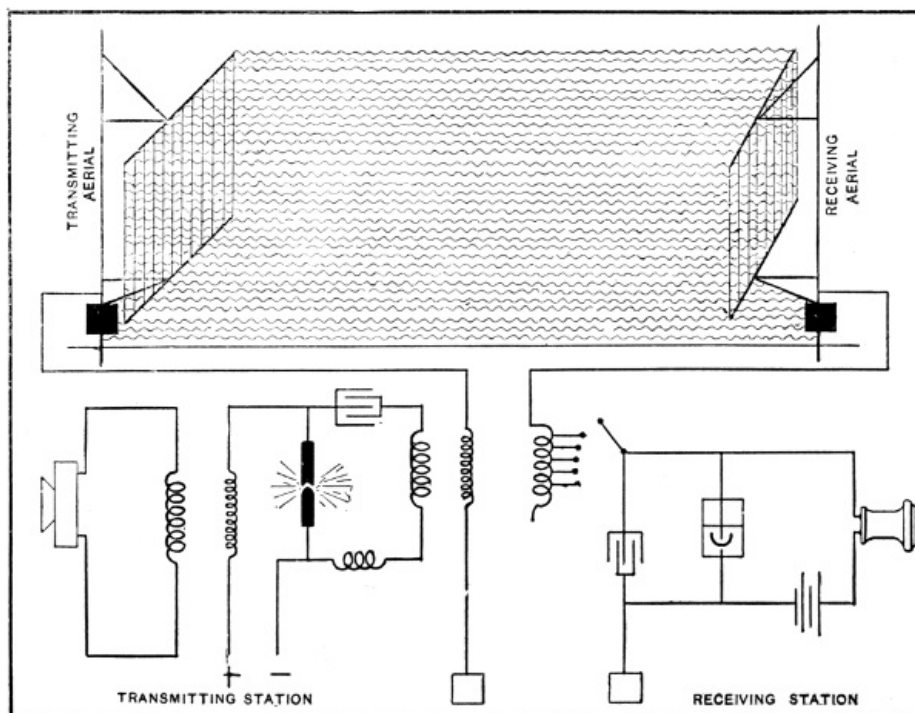

No. 13.—The S. & C. Series. Price 1/6 net.

Practical Electric

A Universal Handy Book

ON

ELECTRIC BELLS, BATTERIES, ACCUMULATORS,
DYNAMOS, MOTORS, INDUCTION AND INTENSITY COILS,
TELEPHONES, MICROPHONES, PHONOGRAPHS,
PHOTOPHONES, ETC.

With 124 Illustrations and 135 pages of Text

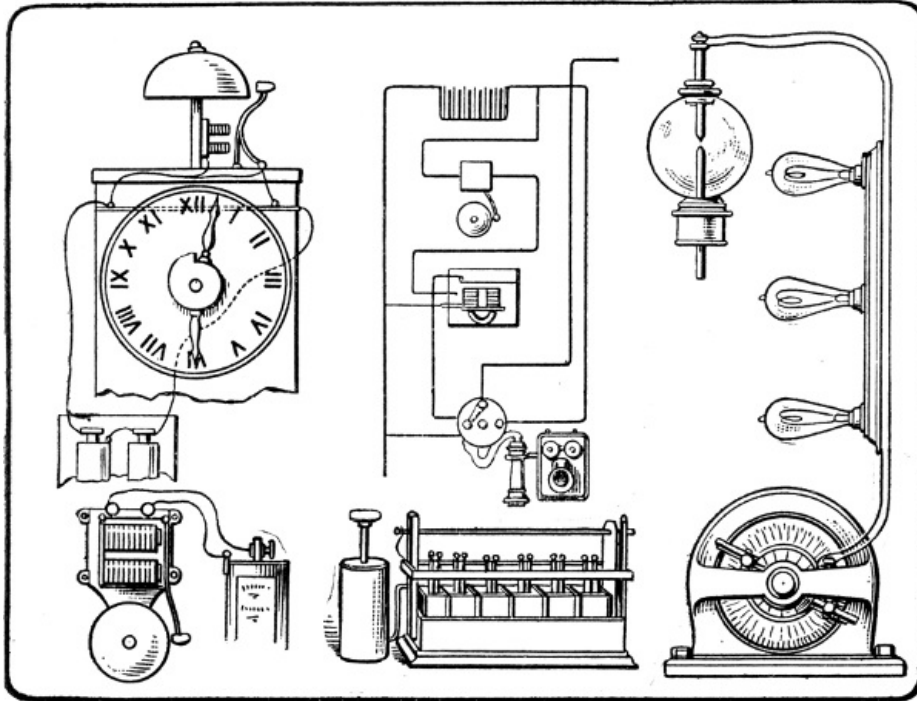

No. 14.—The S. & C. Series. Price 1/6 net.

How To Build A BI-PLANE GLIDER

A PRACTICAL HANDBOOK ON ITS
CONSTRUCTION AND USE

BY

ALFRED POWELL MORGAN

31 Illustrations and 60 pages of Text

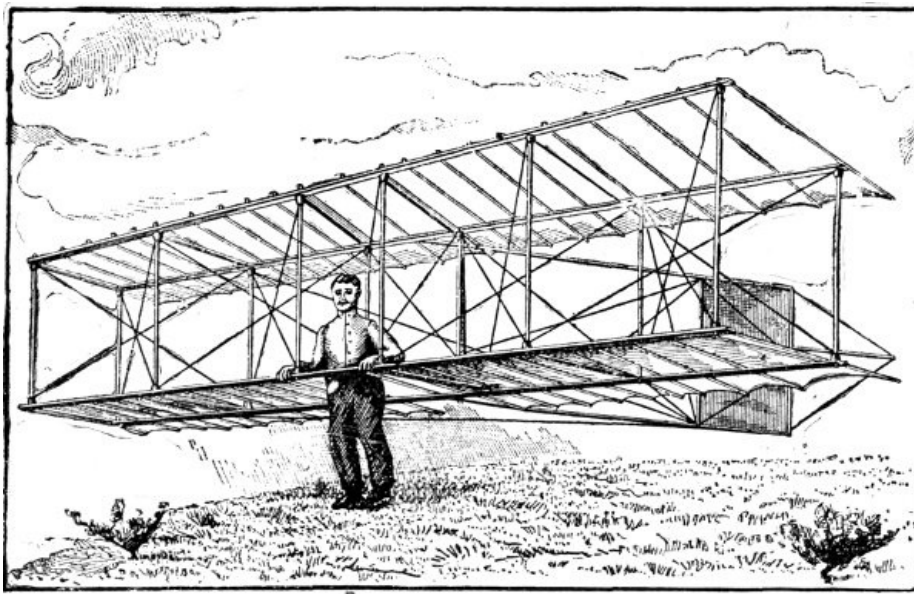

No. 15.—The S. & C. Series. Price 1/6 net.

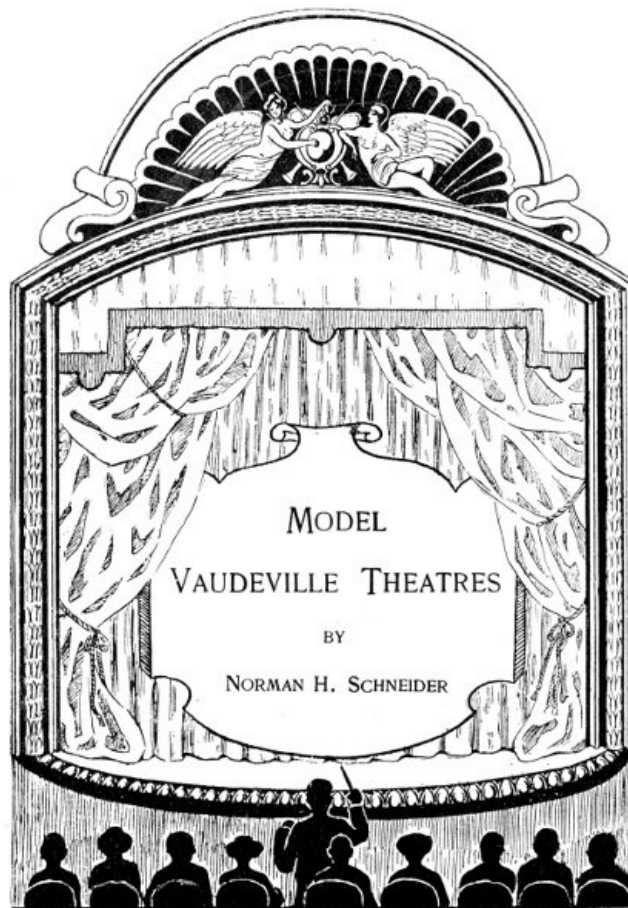

**MODEL
VAUDEVILLE THEATRES**

BY

NORMAN H. SCHNEIDER

With 34 Illustrations and 90 pages of Text

No. 16.—The S. & C. Series. Price 1/6 net.

THE FIREMAN'S GUIDE AND HANDBOOK ON THE CARE OF BOILERS

BY

KARL P. DAHLSTROM, M.E.

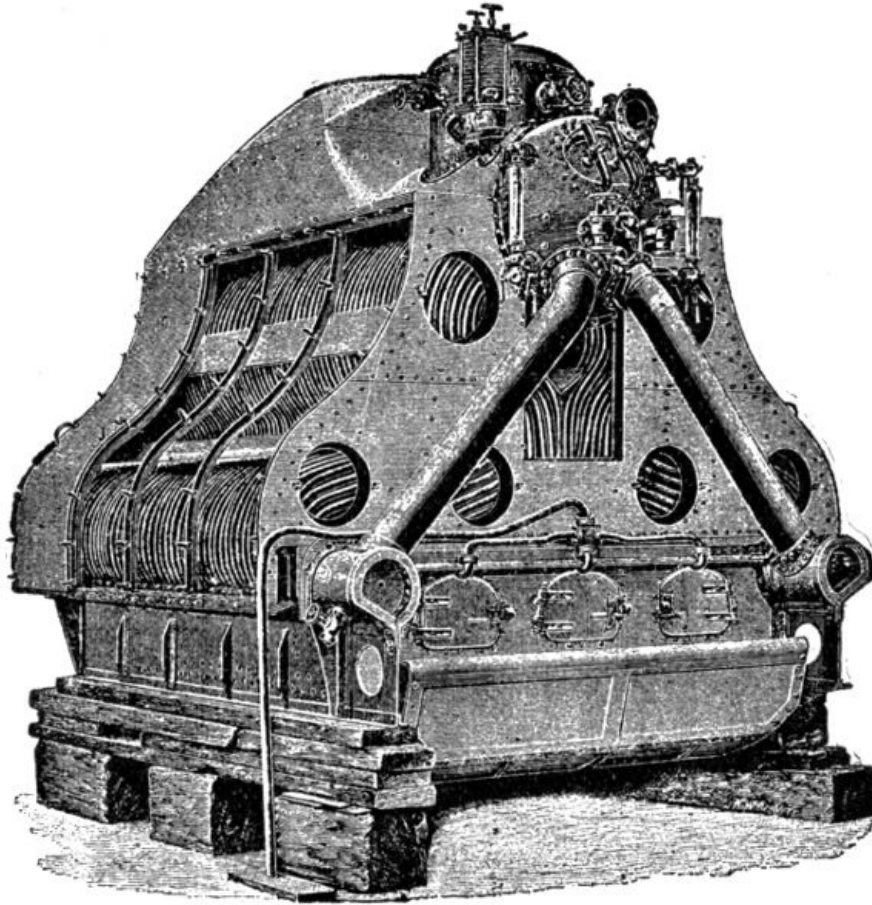

No. 17.—The S. & C. Series. Price 1/6 net.

A B C OF THE STEAM ENGINE AND AUTOMATIC GOVERNOR

Six scale drawings of a High Speed Steam Engine and Automatic Governor. Each part is given in detail with its name and number for easy reference, with description. With a chapter on Lubrication and other practical information.

BY

J. P. LISK, M.E.

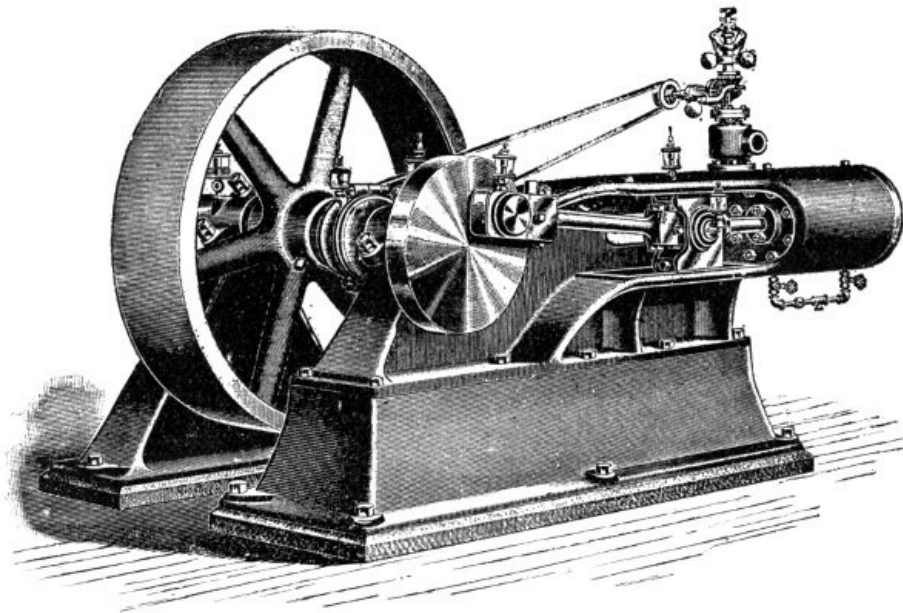

No. 18.—The S. & C. Series. Price 1/6 net.

SIMPLE SOLDERING

BOTH
HARD AND SOFT

Together with Descriptions
of Inexpensive Home
Made Apparatus Necessary
for the Art.

By

EDWARD THATCHER

Instructor of
DECORATIVE METAL WORK
COLUMBIA UNIVERSITY
NEW YORK

52 Illustrations and
76 pages of Text.



No. 19.—The S. & C. Series. Price 1/6 net.

**THE CARE AND MANAGEMENT OF
IGNITION ACCUMULATORS
AND
Electric Light for the Million**

CONTAINING

Practical information on the Charging and Repairing of Motor Cycle,
Motor Car, and other similar Ignition Accumulators. Also
the adaptation of a slightly larger genus to a unique
system of Electric Lighting

BY

HAROLD H. U. CROSS

With 12 Illustrations and 66 pages of Text

CONTENTS

The Charging of Accumulators—The Repairing of Accumulators—The Accumulator in the Home

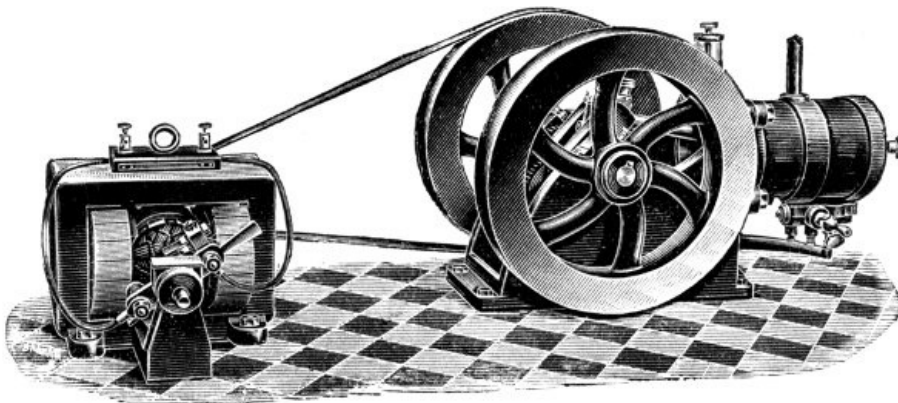

No. 20.—The S. & C. Series. Price 1/6 net.

**A Key
TO THE
Theory and Methods
OF
LINEAR PERSPECTIVE**

BY

CHARLES W. DYMOND, F.S.A.

With 16 Illustrations in 6 Plates, and 32 pages of Text.

The aim of the author of this brief treatise has been to include, within the smallest possible compass, everything that is required to convey to a reader, whose time is limited, a competent knowledge of the theory and the rudiments of the practice of drawing in perspective.

No. 21.—The S. & C. Series. Price 1/6 net.

**ELEMENTS OF
TELEPHONY**

BY

ARTHUR CROTCH

Silver Medallist and Honoursman in Telegraphy, and Honoursman in Telephony, City and Guilds of London Institute, sometime Lecturer in these subjects at the Municipal Technical Schools, Norwich

With 51 Illustrations and 90 pages of Text

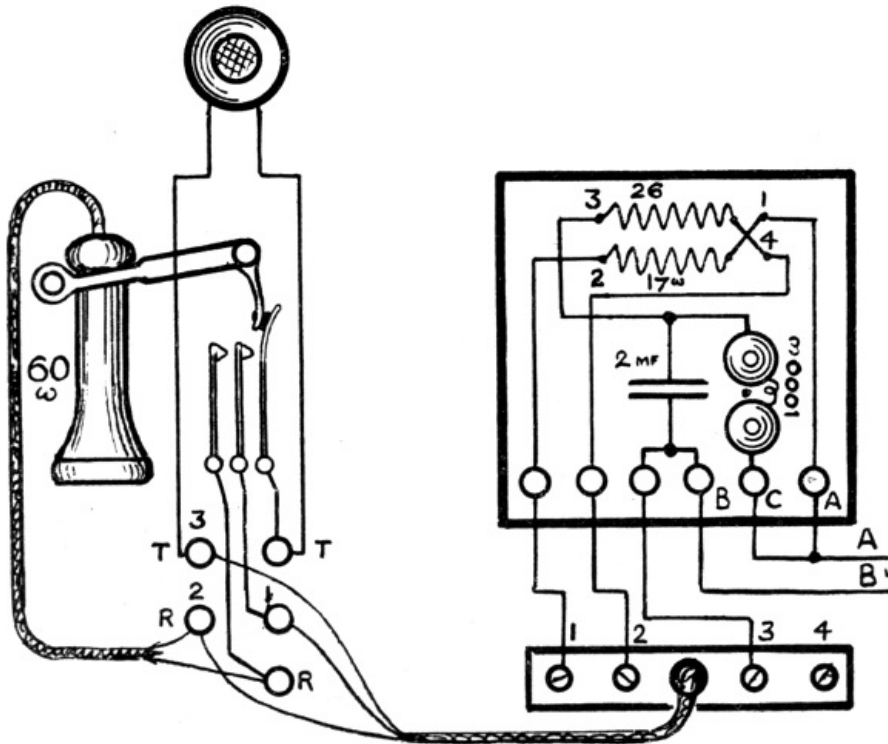

No. 22.—The S. & C. Series. Price 1/6 net.

THE GYROSCOPE **An Experimental Study**

FROM SPINNING TOP TO MONORAIL

BY

V. E. JOHNSON, M.A.

*Author of "The Theory and Practice of Model Aeroplanes."
Formerly Exhibitioner of Magdalene College, Cambridge.*

With 34 Illustrations and 40 pages of text.

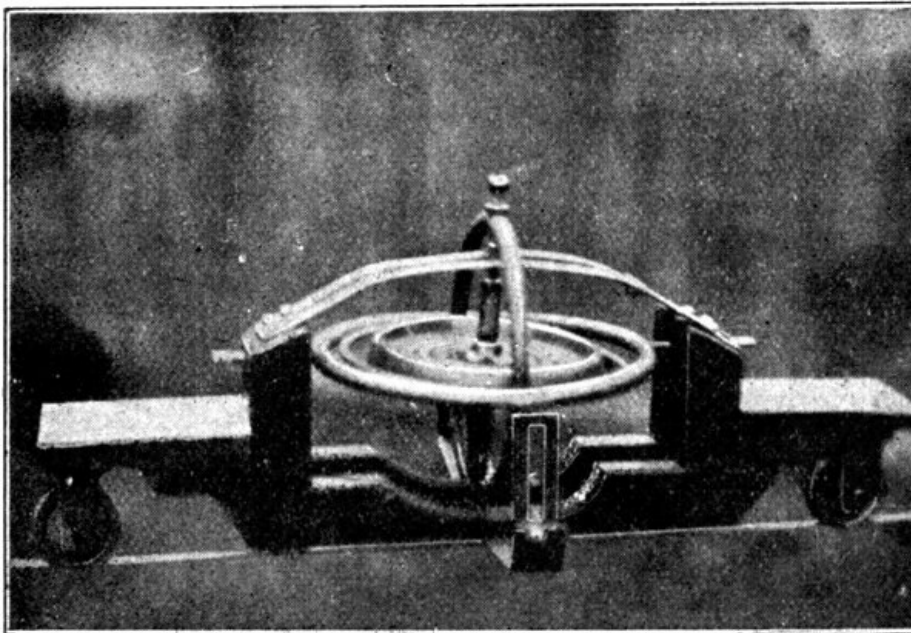

No. 23.—The S. & C. Series. Price 1/6 net.

**THE
CORLISS ENGINE**

BY

JOHN T. HENTHORN

AND

ITS MANAGEMENT

BY

CHARLES D. THURBER

With 22 Illustrations and 95 pages of Text.

CONTENTS:

Introductory and Historical—Steam Jacketing—Indicator Cards—The Governor—Valve Gear and Eccentric—Valve Setting—Table for Laps of Steam Valve—Lubrication—Discussion of the Air Pump and its Management—Care of Main Driving Gears—Best Lubricator for Main Driving Gears—Heating of Mills by Exhaust Steam—Engine Foundations—Diagrams and Templets for Foundations—Materials for Foundations—Proportions of Corliss Engines—Horse-power and General Dimensions—Principal Dimensions of Corliss Engines.

No. 24.—The S. & C. Series. Price 1/6 net.

**Operator's Handbook of
WIRELESS TELEGRAPHY**

A Simple Treatise upon the Theory and Working
of Commercial Wireless Telegraphy for the
Assistance of Intending Wireless
Operators

BY

C. K. P. EDEN, B.Sc., etc.

*Consulting Engineer for Wireless Telegraphy Installations
also Electrotherapeutic and Radiography Specialist.*

In the Press.

CONTENTS.

Detectors—Transmitters—Tuning Apparatus—Wireless
Station Equipment—Aerials and Earths—Small
Power Experimental Apparatus.

No. 25.—The S. & C. Series. Price 1/6 net.

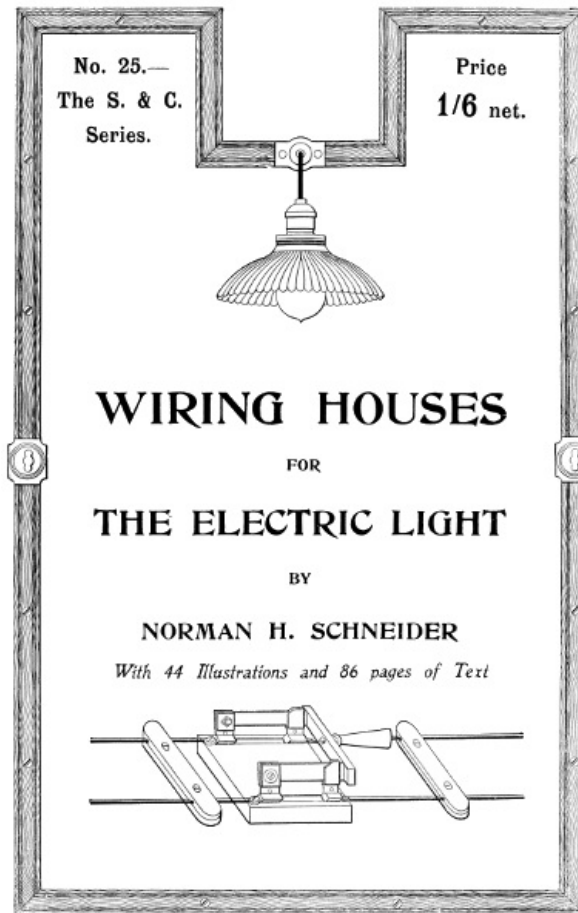

**WIRING HOUSES
FOR
THE ELECTRIC LIGHT**

BY

NORMAN H. SCHNEIDER

With 44 Illustrations and 86 pages of Text

No. 26.—The S. & C. Series. Price 1/6 net.

No. 26.—The S. & C. Series.

Price 1/6 net.



**LOW VOLTAGE
ELECTRIC LIGHTING
WITH THE
STORAGE BATTERY**

SPECIALLY APPLICABLE TO COUNTRY HOUSES
FARMS, SMALL SETTLEMENTS, YACHTS, ETC.

BY

NORMAN H. SCHNEIDER

23 Illustrations and 85 pages of Text

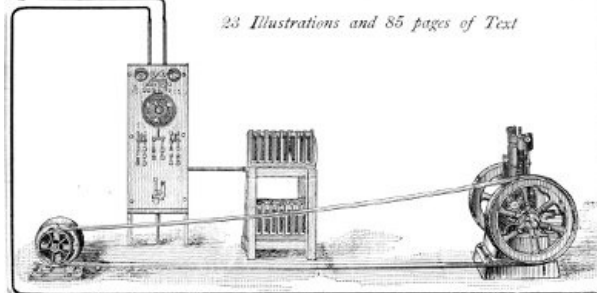

**LOW VOLTAGE
ELECTRIC LIGHTING
WITH THE
STORAGE BATTERY**

SPECIALLY APPLICABLE TO COUNTRY HOUSES,
FARMS, SMALL SETTLEMENTS, YACHTS, ETC.

BY

NORMAN H. SCHNEIDER

23 Illustrations and 85 pages of Text

No. 27.—The S. & C. Series. Price 1/6 net.

**PRACTICAL
SILO CONSTRUCTION**

A TREATISE

*Illustrating and Explaining the most Simple and Easiest Practical Methods
of Constructing Concrete Silos of all types; with Unpatented Forms
and Molds. The Data, Information and Working Drawings
given in this book will enable the Concrete Builder to
successfully construct any of the most practical
types of Concrete Silos in use to-day*

BY

A. A. HOUGHTON

Author of "Concrete from Sand Molds," "Ornamental Concrete Without Molds," etc., etc.

18 FULL PAGE ILLUSTRATIONS

New York

THE NORMAN W. HENLEY PUBLISHING CO.
London
E. & F. N. SPON, LTD., 57 HAYMARKET
1911

No. 28.—The S. & C. Series. Price 1/6 net.

MOLDING CONCRETE CHIMNEYS SLATE & ROOF TILES

A PRACTICAL TREATISE

*Explanatory of the Construction of Block and Monolithic Types
of Concrete Chimneys, with easily constructed Molds for
same. The Construction of Monolithic Concrete
Roofs, also the Molding of Concrete Slate,
Roof Tiles and Slabs, are fully
treated*

BY

A. A. HOUGHTON

Author of "Concrete from Sand Molds," "Ornamental Concrete Without Molds," etc., etc.

15 FULL PAGE ILLUSTRATIONS

New York
THE NORMAN W. HENLEY PUBLISHING CO.
London
E. & F. N. SPON, LTD., 57 HAYMARKET
1911

No. 29.—The S. & C. Series. Price 1/6 net.

MOLDING & CURING ORNAMENTAL CONCRETE

A PRACTICAL TREATISE

*Covering the Various Methods of Preparing the Molds and
Filling with the Concrete Mixture; Remedying Defects
in the Cast; Surface Treatment for various effects;
the proper Proportions and Preparation of the
Concrete, and the best Methods of thoroughly
Curing the Work*

BY

A. A. HOUGHTON

Author of "Concrete from Sand Molds," "Ornamental Concrete Without Molds," etc., etc.

5 FULL PAGE ILLUSTRATIONS

New York
THE NORMAN W. HENLEY PUBLISHING CO.
London
E. & F. N. SPON, LTD., 57 HAYMARKET
1911

No. 30.—The S. & C. Series. Price 1/6 net.

CONCRETE WALL FORMS

A PRACTICAL TREATISE

Explanatory of the Construction of all types of Wall Forms, Clamps, Separators and Spacers for Reinforcement. Full Details and Working Drawings of an Automatic Wall Clamp are given, with the operation of same on all styles of Walls. Foundations, Retaining Walls, Placing Floor Joints, Molding Water Tables and Window Ledges, as well as Molding Fire-proof Floors and Preparing Foundations for Concrete Walls, are also fully treated

BY

A. A. HOUGHTON

Author of "Concrete from Sand Molds," "Ornamental Concrete Without Molds," etc., etc.

16 FULL PAGE ILLUSTRATIONS

New York
THE NORMAN W. HENLEY PUBLISHING CO.
London
E. & F. N. SPON, LTD., 57 HAYMARKET
1911

No. 31.—The S. & C. Series. Price 1/6 net.

CONCRETE MONUMENTS MAUSOLEUMS AND BURIAL VAULTS

A PRACTICAL TREATISE

Explanatory of the Molding of various types of Concrete Monuments, with the Construction of Molds for same. Lettering and Ornamental Effects, with simple methods of securing the desired results, are fully treated. Plans and Designs for Mausoleums and Burial Vaults are given, with complete Details of Construction

BY

A. A. HOUGHTON

Author of "Concrete from Sand Molds," "Ornamental Concrete Without Molds," etc., etc.

18 FULL PAGE ILLUSTRATIONS

New York
THE NORMAN W. HENLEY PUBLISHING CO.
London
E. & F. N. SPON, LTD., 57 HAYMARKET
1911

No. 32.—The S. & C. Series. Price 1/6 net.

CONCRETE FLOORS & SIDEWALKS

A PRACTICAL TREATISE

Explaining the Molding of Concrete Floor and Sidewalk Units with Plain and Ornamental Surfaces, also the Construction of Plain and Reinforced Monolithic Floors and Sidewalks. Complete Instructions are given for all classes of this work, with Illustrations of the easily constructed Molds for Diamond, Hexagonal and Octagonal Floor Tile

BY

A. A. HOUGHTON

Author of "Concrete from Sand Molds," "Ornamental Concrete Without Molds," etc., etc.

8 FULL PAGE ILLUSTRATIONS

New York
THE NORMAN W. HENLEY PUBLISHING CO.
London
E. & F. N. SPON, LTD., 57 HAYMARKET
1911

No. 33.—The S. & C. Series. Price 1/6 net.

**MOLDING CONCRETE
BATH TUBS, AQUARIUMS AND
NATATORIUMS**

A PRACTICAL TREATISE

Explaining the Molding in Concrete of Various Styles of Bath Tubs, Laundry Trays, etc., with Easily Constructed Molds for the purpose. The Molding of Aquariums and Natatoriums, as well as the Water-proofing Methods used for same, are fully treated

BY

A. A. HOUGHTON

16 FULL PAGE ILLUSTRATIONS

New York
THE NORMAN W. HENLEY PUBLISHING CO.
London
E. & F. N. SPON, LTD., 57 HAYMARKET
1911

No. 39.—The S. & C. Series. Price 1/6 net.

**NATURAL STABILITY
AND
THE PARACHUTE PRINCIPLE
IN
AEROPLANES**

BY

W. LEMAITRE

Hon. Sec., Aeroplane Building and Flying Society

With 34 Illustrations and 48 pages of Text

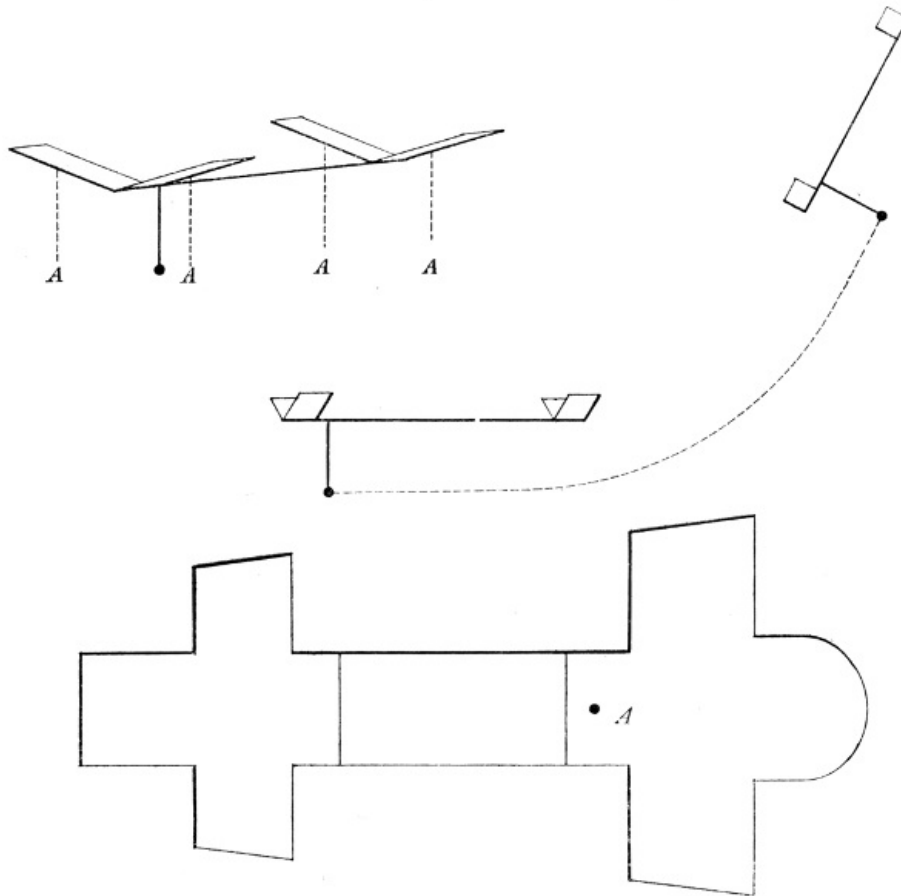

Preface—The Importance of Stability—Speed as a Means of Stability—The Low Centre of Gravity—Short Span and Area—Variable Speed and the Parachute Principle—The Design which fulfils the Conditions.

No. 40.—The S. & C. Series. Price 1/6 net.

BUILDERS' QUANTITIES

BY

HORACE M. LEWIS

*Associate Institution of Municipal and County Engineers
Member of Royal Sanitary Institute
Lecturer on Builders' Quantities, Poole School of Technology*

CONTENTS

General Introduction—How to Measure Areas, with worked Examples
—**Methods of Measurement:** Excavator—Sewers and House Drains—Bricklayer
—Reinforced Concrete—Mason—Slater—Slate Mason—Tiler—Stone, Tiling and
Slating—Plasterer—Carpenter—Joiner and Ironmonger—Smith and Founder—Hot
Water System— Lighting—Bells—Plumber—Painter, Glazier and Paperhanger
—**Examples of Billing.**

With 6 Illustrations and 54 pages of Text

This work is intended to give an elementary knowledge of the subject of Builders' Quantities, and to meet the want for a cheap yet reliable handbook, within the reach of every building student and all engaged in the Building Trade. With this work any one connected with the Trade can measure up efficiently according to the customary methods of measurement, in the "London Standard."

THE S. & C. SERIES

Uniform, in cloth, Price 1s. 6d. net each.

- [1. Modern Primary Batteries.](#) By N. H. SCHNEIDER.
- [2. How to Install Electric Bells, Annunciators and Alarms.](#) By N. H. SCHNEIDER.
- [3. Electrical Circuits and Diagrams, Part I.](#) By N. H. SCHNEIDER.
- [4. Electrical Circuits and Diagrams, Part II.](#) By N. H. SCHNEIDER.
- [5. Experimenting with Induction Coils.](#) By N. H. SCHNEIDER (*H. S. Norrie*).
- [6. The Study of Electricity for Beginners.](#) By N. H. SCHNEIDER.
- [7. Dry Batteries, how to make and Use them.](#) By A DRY BATTERY EXPERT.
- [8. Electric Gas Lighting.](#) By N. H. SCHNEIDER.
- [9. Model Steam Engine Design.](#) By R. M. DE VIGNIER.
- [10. Inventions, how to Protect, Sell and Buy Them.](#) By F. B. WRIGHT.
- [11. Making Wireless Outfits.](#) By N. HARRISON.
- [12. Wireless Telephone Construction.](#) By N. HARRISON.
- [13. Practical Electricians; a Universal Handy Book on Everyday Electrical Matters.](#)
- [14. How to Build a 20-foot Bi-plane Glider.](#) By A. P. MORGAN.
- [15. The Model Vaudeville Theatre.](#) By N. H. SCHNEIDER.
- [16. The Fireman's Guide; a Handbook on the Care of Boilers.](#) By K. P. DAHLSTROM.
- [17. A.B.C. of the Steam Engine, with a Description of the Automatic Governor.](#) By J. P. LISK.
- [18. Simple Soldering, both Hard and Soft.](#) By E. THATCHER.
- [19. Ignition Accumulators, their Care and Management.](#) By H. H. U. CROSS.
- [20. Key to Linear Perspective.](#) By C. W. DYMOND, F.S.A..
- [21. Elements of Telephony.](#) By ARTHUR CROTCH.
- [22. Experimental Study of the Gyroscope.](#) By V. E. JOHNSON, M.A..
- [23. The Corliss Engine.](#) By J. T. HENTHORN.
- [24. Wireless Telegraphy for Intending Operators.](#) By C. K. P. EDEN.
- [25. Wiring Houses for the Electric Light.](#) By N. H. SCHNEIDER.
- [26. Low Voltage Electric Lighting with the Storage Battery.](#) By N. H. SCHNEIDER.
- [27. Practical Silo Construction in Concrete.](#) By A. A. HOUGHTON.
- [28. Molding Concrete Chimneys, Slate and Roof Tiles.](#) By A. A. HOUGHTON.
- [29. Molding and Curing Ornamental Concrete.](#) By A. A. HOUGHTON.
- [30. Concrete Wall Forms.](#) By A. A. HOUGHTON.
- [31. Concrete Monuments, Mausoleums and Burial Vaults.](#) By A. A. HOUGHTON.
- [32. Concrete Floors and Sidewalks.](#) By A. A. HOUGHTON.
- [33. Molding Concrete Bath Tubs, Aquariums and Natatoriums.](#) By A. A. HOUGHTON.
- 34 to 38 inclusive. *Works on Concrete Structures, by A. A. Houghton, and now in the Press.*
- [39. Natural Stability and the Parachute Principle in Aeroplanes.](#) By W. LEMAITRE.
- [40. Builders' Quantities.](#) By H. M. LEWIS.

E. & F. N. SPON, Ltd., LONDON.

*** END OF THE PROJECT GUTENBERG EBOOK A COMPLETE LIST OF THE BOOKS INCLUDED IN THE S. & C. SERIES OF ELEMENTARY MANUALS FOR MECHANICS AND STUDENTS PUBLISHED BY E. & F. N. SPON, LTD., LONDON. JANUARY 1912 ***

Updated editions will replace the previous one—the old editions will be renamed.

Creating the works from print editions not protected by U.S. copyright law means that no one owns a United States copyright in these works, so the Foundation (and you!) can copy and distribute it in the United States without permission and without paying copyright royalties. Special rules, set forth in the General Terms of Use part of this license, apply to copying and distributing Project Gutenberg™ electronic works to protect the PROJECT GUTENBERG™ concept and trademark. Project Gutenberg is a registered trademark, and may not be used if you charge for an eBook, except by following the terms of the trademark license, including paying royalties for use of the Project Gutenberg trademark. If you do not charge anything for copies of this eBook, complying with the trademark license is very easy. You may use this eBook for nearly any purpose such as creation of derivative works, reports, performances and research. Project Gutenberg eBooks may be modified and printed and given away—you may do practically ANYTHING in the United States with eBooks not protected by U.S. copyright law. Redistribution is subject to the trademark license, especially commercial redistribution.

START: FULL LICENSE
THE FULL PROJECT GUTENBERG LICENSE

To protect the Project Gutenberg™ mission of promoting the free distribution of electronic works, by using or distributing this work (or any other work associated in any way with the phrase “Project Gutenberg”), you agree to comply with all the terms of the Full Project Gutenberg™ License available with this file or online at www.gutenberg.org/license.

Section 1. General Terms of Use and Redistributing Project Gutenberg™ electronic works

1.A. By reading or using any part of this Project Gutenberg™ electronic work, you indicate that you have read, understand, agree to and accept all the terms of this license and intellectual property (trademark/copyright) agreement. If you do not agree to abide by all the terms of this agreement, you must cease using and return or destroy all copies of Project Gutenberg™ electronic works in your possession. If you paid a fee for obtaining a copy of or access to a Project Gutenberg™ electronic work and you do not agree to be bound by the terms of this agreement, you may obtain a refund from the person or entity to whom you paid the fee as set forth in paragraph 1.E.8.

1.B. “Project Gutenberg” is a registered trademark. It may only be used on or associated in any way with an electronic work by people who agree to be bound by the terms of this agreement. There are a few things that you can do with most Project Gutenberg™ electronic works even without complying with the full terms of this agreement. See paragraph 1.C below. There are a lot of things you can do with Project Gutenberg™ electronic works if you follow the terms of this agreement and help preserve free future access to Project Gutenberg™ electronic works. See paragraph 1.E below.

1.C. The Project Gutenberg Literary Archive Foundation (“the Foundation” or PGLAF), owns a compilation copyright in the collection of Project Gutenberg™ electronic works. Nearly all the individual works in the collection are in the public domain in the United States. If an individual work is unprotected by copyright law in the United States and you are located in the United States, we do not claim a right to prevent you from copying, distributing, performing, displaying or creating derivative works based on the work as long as all references to Project Gutenberg are removed. Of course, we hope that you will support the Project Gutenberg™ mission of promoting free access to electronic works by freely sharing Project Gutenberg™ works in compliance with the terms of this agreement for keeping the Project Gutenberg™ name associated with the work. You can easily comply with the terms of this agreement by keeping this work in the same format with its attached full Project Gutenberg™ License when you share it without charge with others.

1.D. The copyright laws of the place where you are located also govern what you can do with this work. Copyright laws in most countries are in a constant state of change. If you are outside the United States, check the laws of your country in addition to the terms of this agreement before downloading, copying, displaying, performing, distributing or creating derivative works based on this work or any other Project Gutenberg™ work. The Foundation makes no representations concerning the copyright status of any work in any country other than the United States.

1.E. Unless you have removed all references to Project Gutenberg:

1.E.1. The following sentence, with active links to, or other immediate access to, the full Project Gutenberg™ License must appear prominently whenever any copy of a Project Gutenberg™ work (any work on which the phrase “Project Gutenberg” appears, or with which the phrase “Project Gutenberg” is associated) is accessed, displayed, performed, viewed, copied or distributed:

This eBook is for the use of anyone anywhere in the United States and most other parts of the world at no cost and with almost no restrictions whatsoever. You may copy it, give it away or re-use it under the terms of the Project Gutenberg License included with this eBook or online at www.gutenberg.org. If you are not located in the United States, you will have to check the laws of the country where you are located before using this eBook.

1.E.2. If an individual Project Gutenberg™ electronic work is derived from texts not protected by U.S. copyright law (does not contain a notice indicating that it is posted with permission of the copyright holder), the work can be copied and distributed to anyone in the United States without paying any fees or charges. If you are redistributing or providing access to a work with the phrase “Project Gutenberg” associated with or appearing on the work, you must comply either with the requirements of paragraphs 1.E.1 through 1.E.7 or obtain permission for the use of the work and the Project Gutenberg™ trademark as set forth in paragraphs 1.E.8 or 1.E.9.

1.E.3. If an individual Project Gutenberg™ electronic work is posted with the permission of the copyright holder, your use and distribution must comply with both paragraphs 1.E.1 through 1.E.7 and any additional terms imposed by the copyright holder. Additional terms will be linked to the Project Gutenberg™ License for all works posted with the permission of

the copyright holder found at the beginning of this work.

1.E.4. Do not unlink or detach or remove the full Project Gutenberg™ License terms from this work, or any files containing a part of this work or any other work associated with Project Gutenberg™.

1.E.5. Do not copy, display, perform, distribute or redistribute this electronic work, or any part of this electronic work, without prominently displaying the sentence set forth in paragraph 1.E.1 with active links or immediate access to the full terms of the Project Gutenberg™ License.

1.E.6. You may convert to and distribute this work in any binary, compressed, marked up, nonproprietary or proprietary form, including any word processing or hypertext form. However, if you provide access to or distribute copies of a Project Gutenberg™ work in a format other than “Plain Vanilla ASCII” or other format used in the official version posted on the official Project Gutenberg™ website (www.gutenberg.org), you must, at no additional cost, fee or expense to the user, provide a copy, a means of exporting a copy, or a means of obtaining a copy upon request, of the work in its original “Plain Vanilla ASCII” or other form. Any alternate format must include the full Project Gutenberg™ License as specified in paragraph 1.E.1.

1.E.7. Do not charge a fee for access to, viewing, displaying, performing, copying or distributing any Project Gutenberg™ works unless you comply with paragraph 1.E.8 or 1.E.9.

1.E.8. You may charge a reasonable fee for copies of or providing access to or distributing Project Gutenberg™ electronic works provided that:

- You pay a royalty fee of 20% of the gross profits you derive from the use of Project Gutenberg™ works calculated using the method you already use to calculate your applicable taxes. The fee is owed to the owner of the Project Gutenberg™ trademark, but he has agreed to donate royalties under this paragraph to the Project Gutenberg Literary Archive Foundation. Royalty payments must be paid within 60 days following each date on which you prepare (or are legally required to prepare) your periodic tax returns. Royalty payments should be clearly marked as such and sent to the Project Gutenberg Literary Archive Foundation at the address specified in Section 4, “Information about donations to the Project Gutenberg Literary Archive Foundation.”
- You provide a full refund of any money paid by a user who notifies you in writing (or by e-mail) within 30 days of receipt that s/he does not agree to the terms of the full Project Gutenberg™ License. You must require such a user to return or destroy all copies of the works possessed in a physical medium and discontinue all use of and all access to other copies of Project Gutenberg™ works.
- You provide, in accordance with paragraph 1.F.3, a full refund of any money paid for a work or a replacement copy, if a defect in the electronic work is discovered and reported to you within 90 days of receipt of the work.
- You comply with all other terms of this agreement for free distribution of Project Gutenberg™ works.

1.E.9. If you wish to charge a fee or distribute a Project Gutenberg™ electronic work or group of works on different terms than are set forth in this agreement, you must obtain permission in writing from the Project Gutenberg Literary Archive Foundation, the manager of the Project Gutenberg™ trademark. Contact the Foundation as set forth in Section 3 below.

1.F.

1.F.1. Project Gutenberg volunteers and employees expend considerable effort to identify, do copyright research on, transcribe and proofread works not protected by U.S. copyright law in creating the Project Gutenberg™ collection. Despite these efforts, Project Gutenberg™ electronic works, and the medium on which they may be stored, may contain “Defects,” such as, but not limited to, incomplete, inaccurate or corrupt data, transcription errors, a copyright or other intellectual property infringement, a defective or damaged disk or other medium, a computer virus, or computer codes that damage or cannot be read by your equipment.

1.F.2. LIMITED WARRANTY, DISCLAIMER OF DAMAGES - Except for the “Right of Replacement or Refund” described in paragraph 1.F.3, the Project Gutenberg Literary Archive Foundation, the owner of the Project Gutenberg™ trademark, and any other party distributing a Project Gutenberg™ electronic work under this agreement, disclaim all liability to you for damages, costs and expenses, including legal fees. YOU AGREE THAT YOU HAVE NO REMEDIES FOR NEGLIGENCE, STRICT LIABILITY, BREACH OF WARRANTY OR BREACH OF CONTRACT EXCEPT THOSE PROVIDED IN PARAGRAPH 1.F.3. YOU AGREE THAT THE FOUNDATION, THE TRADEMARK OWNER, AND ANY DISTRIBUTOR UNDER THIS AGREEMENT WILL NOT BE LIABLE TO YOU FOR ACTUAL, DIRECT, INDIRECT, CONSEQUENTIAL, PUNITIVE OR INCIDENTAL DAMAGES EVEN IF YOU GIVE NOTICE OF

THE POSSIBILITY OF SUCH DAMAGE.

1.F.3. LIMITED RIGHT OF REPLACEMENT OR REFUND - If you discover a defect in this electronic work within 90 days of receiving it, you can receive a refund of the money (if any) you paid for it by sending a written explanation to the person you received the work from. If you received the work on a physical medium, you must return the medium with your written explanation. The person or entity that provided you with the defective work may elect to provide a replacement copy in lieu of a refund. If you received the work electronically, the person or entity providing it to you may choose to give you a second opportunity to receive the work electronically in lieu of a refund. If the second copy is also defective, you may demand a refund in writing without further opportunities to fix the problem.

1.F.4. Except for the limited right of replacement or refund set forth in paragraph 1.F.3, this work is provided to you 'AS-IS', WITH NO OTHER WARRANTIES OF ANY KIND, EXPRESS OR IMPLIED, INCLUDING BUT NOT LIMITED TO WARRANTIES OF MERCHANTABILITY OR FITNESS FOR ANY PURPOSE.

1.F.5. Some states do not allow disclaimers of certain implied warranties or the exclusion or limitation of certain types of damages. If any disclaimer or limitation set forth in this agreement violates the law of the state applicable to this agreement, the agreement shall be interpreted to make the maximum disclaimer or limitation permitted by the applicable state law. The invalidity or unenforceability of any provision of this agreement shall not void the remaining provisions.

1.F.6. INDEMNITY - You agree to indemnify and hold the Foundation, the trademark owner, any agent or employee of the Foundation, anyone providing copies of Project Gutenberg™ electronic works in accordance with this agreement, and any volunteers associated with the production, promotion and distribution of Project Gutenberg™ electronic works, harmless from all liability, costs and expenses, including legal fees, that arise directly or indirectly from any of the following which you do or cause to occur: (a) distribution of this or any Project Gutenberg™ work, (b) alteration, modification, or additions or deletions to any Project Gutenberg™ work, and (c) any Defect you cause.

Section 2. Information about the Mission of Project Gutenberg™

Project Gutenberg™ is synonymous with the free distribution of electronic works in formats readable by the widest variety of computers including obsolete, old, middle-aged and new computers. It exists because of the efforts of hundreds of volunteers and donations from people in all walks of life.

Volunteers and financial support to provide volunteers with the assistance they need are critical to reaching Project Gutenberg™'s goals and ensuring that the Project Gutenberg™ collection will remain freely available for generations to come. In 2001, the Project Gutenberg Literary Archive Foundation was created to provide a secure and permanent future for Project Gutenberg™ and future generations. To learn more about the Project Gutenberg Literary Archive Foundation and how your efforts and donations can help, see Sections 3 and 4 and the Foundation information page at www.gutenberg.org.

Section 3. Information about the Project Gutenberg Literary Archive Foundation

The Project Gutenberg Literary Archive Foundation is a non-profit 501(c)(3) educational corporation organized under the laws of the state of Mississippi and granted tax exempt status by the Internal Revenue Service. The Foundation's EIN or federal tax identification number is 64-6221541. Contributions to the Project Gutenberg Literary Archive Foundation are tax deductible to the full extent permitted by U.S. federal laws and your state's laws.

The Foundation's business office is located at 809 North 1500 West, Salt Lake City, UT 84116, (801) 596-1887. Email contact links and up to date contact information can be found at the Foundation's website and official page at www.gutenberg.org/contact

Section 4. Information about Donations to the Project Gutenberg Literary Archive Foundation

Project Gutenberg™ depends upon and cannot survive without widespread public support and donations to carry out its mission of increasing the number of public domain and licensed works that can be freely distributed in machine-readable form accessible by the widest array of equipment including outdated equipment. Many small donations (\$1 to \$5,000) are particularly important to maintaining tax exempt status with the IRS.

The Foundation is committed to complying with the laws regulating charities and charitable donations in all 50 states of the United States. Compliance requirements are not uniform and it takes a considerable effort, much paperwork and many fees to meet and keep up with these requirements. We do not solicit donations in locations where we have not received written confirmation of compliance. To SEND DONATIONS or determine the status of compliance for

any particular state visit www.gutenberg.org/donate.

While we cannot and do not solicit contributions from states where we have not met the solicitation requirements, we know of no prohibition against accepting unsolicited donations from donors in such states who approach us with offers to donate.

International donations are gratefully accepted, but we cannot make any statements concerning tax treatment of donations received from outside the United States. U.S. laws alone swamp our small staff.

Please check the Project Gutenberg web pages for current donation methods and addresses. Donations are accepted in a number of other ways including checks, online payments and credit card donations. To donate, please visit: www.gutenberg.org/donate

Section 5. General Information About Project Gutenberg™ electronic works

Professor Michael S. Hart was the originator of the Project Gutenberg™ concept of a library of electronic works that could be freely shared with anyone. For forty years, he produced and distributed Project Gutenberg™ eBooks with only a loose network of volunteer support.

Project Gutenberg™ eBooks are often created from several printed editions, all of which are confirmed as not protected by copyright in the U.S. unless a copyright notice is included. Thus, we do not necessarily keep eBooks in compliance with any particular paper edition.

Most people start at our website which has the main PG search facility: www.gutenberg.org.

This website includes information about Project Gutenberg™, including how to make donations to the Project Gutenberg Literary Archive Foundation, how to help produce our new eBooks, and how to subscribe to our email newsletter to hear about new eBooks.