

The Project Gutenberg eBook of Every-day Science: Volume 7. The Conquest of Time and Space, by Edward Huntington Williams and Henry Smith Williams

This ebook is for the use of anyone anywhere in the United States and most other parts of the world at no cost and with almost no restrictions whatsoever. You may copy it, give it away or re-use it under the terms of the Project Gutenberg License included with this ebook or online at www.gutenberg.org. If you are not located in the United States, you'll have to check the laws of the country where you are located before using this eBook.

Title: Every-day Science: Volume 7. The Conquest of Time and Space

Author: Edward Huntington Williams

Author: Henry Smith Williams

Release date: September 27, 2013 [EBook #43819]

Language: English

Credits: Produced by Chris Curnow, Albert László (bertzi), Charlie Howard, and the Online Distributed Proofreading Team at <http://www.pgdp.net> (This file was produced from images generously made available by The Internet Archive)

*** START OF THE PROJECT GUTENBERG EBOOK EVERY-DAY SCIENCE: VOLUME 7. THE CONQUEST OF TIME AND SPACE ***



THE WRIGHT AEROPLANE IN FRANCE IN 1908.

It will be seen that there are two passengers on the aeroplane, one being Mr. Wilbur Wright, the other a pupil.

EVERY-DAY SCIENCE

BY

HENRY SMITH WILLIAMS, M.D., LL.D.

ASSISTED BY

EDWARD H. WILLIAMS, M.D.

VOLUME VII.

THE CONQUEST OF TIME AND SPACE

ILLUSTRATED



NEW YORK AND LONDON
THE GOODHUE COMPANY
PUBLISHERS • MDCCCCX

Copyright, 1910, by THE GOODHUE Co.
All rights reserved

CONTENTS

CHAPTER I

THE CONQUEST OF THE ZONES

Geographical knowledge of the ancient Egyptians, p. [5](#)—The mariner's compass, p. [7](#)—Reference to the thirty-two points of the compass by Chaucer, p. [9](#)—Halley's observations on the changes in the direction of the compass in a century, p. [10](#)—Deviation of the compass, p. [11](#)—The voyage of the *Carnegie*, the non-magnetic ship, p. [12](#)—The "dip of the needle" first observed by Robert Norman, p. [13](#)—The modern compass invented by Lord Kelvin, p. [14](#)—Sailing by dead reckoning, p. [14](#)—The invention of the "log," p. [15](#)—The modern log, p. [17](#)—The development of the sextant, p. [18](#)—The astrolabe, p. [19](#)—The quadrant invented by Hadley, p. [20](#)—The perfected sextant, p. [21](#)—Perfecting the chronometer, p. [23](#)—The timepieces invented by the British carpenter, John Harrison, p. [25](#)—The prize won by Harrison, p. [27](#)—Finding time without a chronometer, p. [28](#)—The *Nautical Almanac*, p. [30](#)—Ascertaining the ship's longitude, p. [31](#)—Difficulties of "taking the sun" at noon, p. [33](#)—Measuring a degree of latitude, p. [34](#)—The observations of Robert Norman, p. [35](#)—The function of the *Nautical Almanac*, p. [37](#)—Soundings and charts, p. [41](#)—Mercator's projection, p. [44](#)—The lure of the unknown, p. [45](#)—The quest of the Pole, p. [47](#)—Commander Peary's achievement, p. [49](#)—How observations are made in arctic regions, p. [50](#)—Making observations at the Pole, p. [52](#)—Difficulties as to direction at the Pole, p. [54](#).

CHAPTER II

THE HIGHWAY OF THE WATERS

Use of sails in ancient times, p. [56](#)—Ships with many banks of oars, p. [57](#)—Mediæval ships, p. [59](#)—Modern sailing ships, p. [60](#)—The sailing record of *The Sovereign of the Seas*, p. [60](#)—Early attempts to invent a steamboat, p. [63](#)—Robert Fulton's *Clermont*, p. [64](#)—The steamboat of Blasco de Gary, p. [66](#)—The *Charlotte Dundas*, p. [67](#)—The steamboat invented by Col. John Stevens, p. [68](#)—Fulton designs the *Clermont*, p. [71](#)—The historic trip of the *Clermont* up the Hudson, p. [71](#)—Sea-going steamships, p. [73](#)—Ships built of iron and steel, p. [74](#)—The *Great Eastern*, p. [76](#)—Principal dimensions of the *Great Eastern*, p. [78](#)—Twin-screw vessels, p. [80](#)—The triumph of the turbine, p. [81](#)—The *Lusitania* and *Mauretania*, p. [82](#)—Submarine signalling, p. [83](#)—The rescue of the *Republic*, p. [84](#)—How the submarine signalling device works, p. [86](#)—The *Olympic* and *Titanic*, p. [90](#)—Liquid fuel, p. [90](#)—Advantages and disadvantages of liquid fuel, p. [91](#).

iv

CHAPTER III

SUBMARINE VESSELS

Slow development of submarine navigation, p. [93](#)—The first submarine, p. [94](#)—Description of David Bushnell's boat, p. [94](#)—Attempts to sink a war vessel during the American Revolution, p. [97](#)—Robert Fulton's experiments, p. [98](#)—The attack on the *Argus* by Fulton's submarine, p. [100](#)—The attack upon the *Ramilles* in 1813, p. [102](#)—A successful diving boat, p. [103](#)—The sinking of the *Housatonic*, p. [104](#)—Recent submarines and submersibles, p. [105](#)—The *Holland*, p. [106](#)—The Lake type of boat, p. [108](#)—Problems to be overcome in submarine navigation, p. [109](#)—Present status of submarine boats, p. [111](#)—The problem of seeing without being seen, p. [113](#)—The experimental attacks upon the cruiser *Yankee* in 1908, p. [115](#)—The possibility of using aeroplanes for detecting the presence of submarines, p. [117](#).

CHAPTER IV

THE STEAM LOCOMOTIVE

The earliest railroad, p. [119](#)—The substitution of flanged wheels for flanged rails, p. [120](#)—The locomotive of Richard Trevithick, p. [121](#)—The cable road of Chapman, p. [123](#)—Stephenson solves the problem, p. [124](#)—Versatility of Stephenson, p. [125](#)—His early locomotives, p. [126](#)—Stephenson's locomotive of 1825, p. [127](#)—The first passenger coach, p. [128](#)—The Liverpool and Manchester Railway projected, p. [129](#)—Conditions named for testing the competing locomotives, p. [130](#)—The *Rocket* and other contestants, p. [132](#)—Description of the *Rocket*, p. [133](#)—Improvements on the construction of the *Rocket*, p. [134](#)—Improvements in locomotives in recent years, p. [135](#)—The compound locomotive, p. [137](#)—Advantages of compound locomotives, p. [138](#)—The Westinghouse air brake, p. [141](#)—The "straight air brake," p. [143](#)—The automatic air brake, p. [144](#)—The high-speed air brake, p. [146](#)—Automatic couplings,

v

p. [147](#)—Principle of the Janney coupling, p. [149](#)—A comparison—the old and the new, p. [150](#).

[CHAPTER V](#)

FROM CART TO AUTOMOBILE

When were carts first used? p. [152](#)—The development of the bicycle, p. [154](#)—The pneumatic tire introduced, p. [155](#)—The coming of the automobile, p. [156](#)—The gas engine of Dr. Otto, p. [157](#)—Cugnot's automobile, p. [158](#)—The automobile of William Murdoch, 1785, p. [158](#)—Opposition in England to the introduction of automobiles, p. [159](#)—An extraordinary piece of legislation, p. [161](#)—Scientific aspects of automobile racing, p. [164](#)—Some records made at Ormonde, p. [165](#)—Records made by Oldfield in 1910, p. [166](#)—Comparative speeds of various vehicles and animals, p. [167](#)—Speed of birds in flight, p. [168](#)—A miraculous transformation of energy, p. [170](#)—Electrical timing device for measuring automobile speeds, p. [171](#).

[CHAPTER VI](#)

THE DEVELOPMENT OF ELECTRIC RAILWAYS

New York the first city to have a street railway, p. [175](#)—Cable systems, p. [177](#)—Early self-sustained systems, p. [178](#)—The electro-magnetic locomotive of Moses G. Farmer, p. [179](#)—The efforts of Professor Page to produce a storage battery car, p. [180](#)—The experiments of Siemens and Halske with electric motors, p. [181](#)—The Edison electric locomotive, p. [182](#)—Third rails and trolleys, p. [184](#)—The inventions of Daft and Van Depoele, p. [185](#)—The work of Frank J. Sprague in developing electric railways, p. [186](#)—How the word "trolley" was coined, p. [187](#)—Storage battery systems, p. [188](#)—The Edison storage battery car of 1910, p. [189](#)—Monorail systems, p. [191](#)—Electric aerial monorail systems, p. [193](#).

[CHAPTER VII](#)

THE GYROCAR

Mr. Louis Brennan's car exhibited before the Royal Society in London, p. [195](#)—How the gyroscope is installed on this car, p. [196](#)—Gyroscopic action explained, p. [197](#)—Why does the spinning wheel exert gyroscopic power? p. [199](#)—Mr. Brennan's model car, p. [200](#)—The "wobble" of the gyroscope explained, p. [202](#)—How the Brennan gyroscopes work, p. [203](#)—Technical explanation of the gyroscope, p. [204](#)—The evolution of an idea, p. [213](#)—Sir Henry Bessemer's experiment, p. [214](#)—What may be expected of the gyrocar, p. [215](#).

vi

[CHAPTER VIII](#)

THE GYROSCOPE AND OCEAN TRAVEL

Bessemer's costly experiment, p. [217](#)—Dr. Schlick's successful experiment, p. [219](#)—The action of Dr. Schlick's invention explained, p. [220](#)—Did gyroscopic action wreck the *Viper*? p. [222](#)—Theoretical dangers of the gyroscope, p. [223](#)—Probable use of the gyroscope on battleships, p. [225](#).

[CHAPTER IX](#)

NAVIGATING THE AIR

Some mediæval traditions about airships, p. [266](#)—The flying machines devised by Leonardo da Vinci, p. [277](#)—The flying machine of Besnier, p. [228](#)—The discovery of hydrogen gas and its effect upon aeronautics, p. [230](#)—The balloon invented, p. [231](#)—The first successful balloon ascension, p. [232](#)—Rozier, the first man to make an ascent in a balloon, p. [235](#)—Blanchard's attempt to produce a dirigible balloon, p. [238](#)—Hot-air balloons and hydrogen-gas balloons, p. [240](#)—Rozier, the first victim of ballooning, p. [241](#)—Progress in mechanical flight, p. [244](#)—Cocking's parachute, p. [245](#)—Henson's studies of the lifting power of plane surfaces, p. [246](#)—The flying machine of Captain Le Bris, p. [248](#)—Giffard "the Fulton of aerial navigation," p. [251](#)—The flights of the *Giant*, p. [252](#)—The record flight of John Wise in 1859, p. [256](#)—Early war balloons and dirigible balloons, p. [257](#)—The use of balloons during the Franco-Prussian war, p. [258](#)—The dirigible balloon achieved, p. [262](#)—The dirigible balloon of Dupuy de Lome, p. [263](#)—The aluminum balloon of Herr Schwartz, p. [264](#)—The dirigible balloons of Count Zeppelin,

CHAPTER X

THE TRIUMPH OF THE AEROPLANE

Balloon versus aeroplane, p. [272](#)—The kite as a flying machine, p. [273](#)—How the air sustains a heavier-than-air mechanism, p. [274](#)—Langley's early experiments, p. [275](#)—Experiments in soaring, p. [277](#)—Lilienthal's imitation of the soaring bird, p. [279](#)—Sir Hiram Maxim's flying machine, p. [283](#)—Langley's successful aerodrome, p. [284](#)—The failure of Langley's larger aerodrome, p. [287](#)—Wilbur and Orville Wright accomplish the impossible, p. [288](#)—The first public demonstration by the Wright brothers, p. [290](#)—The Wright aeroplane described, p. [291](#)—A host of imitators, p. [292](#)—Mr. Henry Farman's successful flights, p. [293](#)—Public demonstrations by the Wright brothers in America and France, p. [293](#)—The English Channel crossed by Blériot, p. [294](#)—Orville Wright fulfils the Government tests, p. [295](#)—Spectacular cross-country flights, p. [296](#)—The Wright brothers the true pioneers, p. [300](#).

ILLUSTRATIONS

THE WRIGHT AEROPLANE IN FRANCE IN 1908	<i>Frontispiece</i>
	<i>Facing page</i>
"TAKING THE SUN" WITH THE SEXTANT	22
THE OLD AND THE NEW—A CONTRAST	60
MARINE ENGINES AND AN EARLY TYPE OF STEAMBOAT	64
THE STEAMSHIPS "CHARLOTTE DUNDAS" AND "CLERMONT"	68
THE "CLERMONT"	72
ROBERT FULTON	98
THE AMERICAN SUBMARINE BOAT "CUTTLEFISH" IN DRY DOCK AT THE BROOKLYN NAVY YARD	108
A FLEET OF BRITISH SUBMARINES MANŒUVERING AT THE SURFACE	116
GEORGE STEPHENSON	124
A CENTURY'S PROGRESS IN LOCOMOTIVE BUILDING	128
CUGNOT'S TRACTION ENGINE AND THE "NOVELTY" LOCOMOTIVE	132
THE FAMOUS LOCOMOTIVES "ROCKET" AND "SANS-PAREIL"	134
THE DEVELOPMENT OF THE LOCOMOTIVE	150
THE HOBBY-HORSE OF 1820 CONTRASTED WITH THE MOTOR CYCLE OF TO-DAY	154
THE EVOLUTION OF THE BICYCLE	156
THE EXTREMES OF AUTOMOBILE DEVELOPMENT	158
AN ENGLISH STEAM COACH OF 1827 AND A NEW YORK TAXICAB OF 1909	162
A RACING AUTOMOBILE	166
RETROSPECT AND PROSPECT IN TRANSPORTATION—THE DE WITT CLINTON TRAIN AND THE GYROCAR	200
TWO VIEWS OF MR. LOUIS BRENNAN'S MONORAIL GYROCAR	216
AN INTERNATIONAL BALLOON RACE	242
TWO FAMOUS FRENCH WAR BALLOONS	264
THE ZEPPELIN DIRIGIBLE BALLOON	266
AN ENGLISH DIRIGIBLE BALLOON	268
ENGLISH AND AMERICAN DIRIGIBLE WAR BALLOONS AND A WRIGHT AEROPLANE	270
THE AEROPLANE OF M. SANTOS-DUMONT	272
LEARNING HOW TO FLY	278
FLYING MACHINES OF THE MONOPLANE TYPE	284
THE WRIGHT AEROPLANE	288
MR. WILBUR WRIGHT PREPARING TO ASCEND IN HIS AEROPLANE WITH HIS PUPIL M. CASSANDIER	292
THE FARMAN AEROPLANE	294
THE MONOPLANES OF BLÉRIOT AND LATHAM	296
A BRITISH AEROPLANE	298
MR. WILBUR WRIGHT FLYING OVER NEW YORK HARBOR, OCTOBER 4, 1909	300

THE CONQUEST OF TIME AND SPACE

INTRODUCTION

THE preceding volume dealt with the general principles of application and transformation of the powers of Nature through which the world's work is carried on. In the present volume we are chiefly concerned with man's application of the same principles in his efforts to set at defiance, so far as may be, the limitations of time and space.

Something has already been said as to the contrast between the material civilization of to-day and that of the generations prior to the nineteenth century. The transformation in methods of agriculture and manufacture has been referred to somewhat in detail. Now we have to do with contrasts that are perhaps even more vivid, since they concern conditions that come within the daily observation of everyone. Steamships, locomotives, electric cars, and automobiles, are such commonplaces of every-day life that it is difficult to conceive a world in which they have no part. Yet everyone is aware that all these mechanisms are inventions of the nineteenth century. Meantime the aeroplane, which bids fair to rival those other means of transportation in the near future, is a creation of the twentieth century. 2

In order to visualize the contrast between the practical civilization of to-day and that of our grandparents, it suffices to recall that the first steam locomotive that carried passengers over a railway was put in operation in the year 1829; and that the first ship propelled by steam power alone did not cross the ocean until 1838. Not until well towards the middle of the nineteenth century, then, were the conditions of transportation altered materially from what they had been since the very dawn of civilization,—conditions under which one hundred miles constituted about the maximum extent of a hard day's land journey.

The elaboration of railway and steamship lines through which nearly all portions of the habitable globe have been made accessible, has constituted one of the most remarkable examples of economic development that man has ever achieved. It requires but the slightest use of the imagination to realize with some measure of vividness the extent to which the entire structure of present-day civilization is based upon this elaboration of means of transportation. To point but a single illustration, the entire central and western portion of the United States must have remained a wilderness for decades or centuries had not the steam locomotive made communication easy between these regions and the seaboard.

Contrariwise no such development of city life as that which we see throughout Christendom would have been possible but for the increased facilities, due primarily to locomotives and steamships, for bringing all essential food-stuffs from distant regions. 3

What this all means when applied on a larger scale may be suggested by the reflection that the entire character of the occupation of the average resident of England has been changed within a century. A century ago England was a self-supporting nation, in the sense that it produced its own food-stuffs. To-day the population of England as a whole is dependent upon food shipped to it from across the oceans. Obviously such a transformation could never have been effected had not the application of steam revolutionized the entire character of transportation.

Far-reaching as are the economic aspects of the problem of transportation, this extraordinary revolution, the effects of which are visible on every side, has been brought about by the application of only a few types of mechanisms. The steam engine, the dynamo, and the gas engine are substantially responsible for the entire development in question. In the succeeding pages, which deal with the development of steamships, locomotives, automobiles, and flying machines, we have to do with the application of principles with which our previous studies have made us familiar; and in particular with the mechanisms that have engaged our attention in the preceding volume. Yet the application of these principles and the utilization of these mechanisms gave full opportunity for the exercise of inventive ingenuity, and the story of the development of steamships, locomotives, electric vehicles, automobiles, gyro cars, and flying machines, will be found to have elements of interest commensurate with the importance of these mechanisms themselves. Before we take up these stories in detail, however, we shall briefly review the story of geographical discovery and exploration in its scientific aspects. 4

THE CONQUEST OF THE ZONES

THE contrast between modern and ancient times is strikingly suggested by reflection on the limited range of geographical knowledge of those Oriental and Classical nations who dominated the scene at that remote period which we are accustomed to characterize as the dawn of history. The Egyptians, peopling the narrow valley of the Nile, scarcely had direct dealings with any people more remote than the Babylonians and Assyrians occupying the valley of the Euphrates. Babylonians and Assyrians in turn were in touch with no Eastern civilization more remote than that of Persia and India, and knew nothing of any Western world beyond the borders of Greece. Greeks and Romans, when in succession they came to dominate the world stage,—developing a civilization which even as viewed from our modern vantage-ground seems marvelous,—were still confined to narrow strips of territory about the shores of the Mediterranean, and had but the vaguest notions as to any other regions of the earth.

In the later classical period, to be sure, the globe was subjected, as we have seen, to wonderful measurements by Eratosthenes and by Posidonius, and the fact that man's abiding place is a great ball utterly different from the world as conceived by the Oriental mind, was definitely grasped and became more or less a matter of common knowledge. It was even conceived that there might be a second habitable zone on the opposite side of the equator from the region in which the Greeks and Romans found themselves, but as to just what this hypothetical region might be like, and as to what manner of beings might people it, even the most daring speculator made no attempt to decide. The more general view, indeed, precluded all thought of habitable regions lying beyond the confines of the Mediterranean civilization; conceiving rather that the world beyond was a mere waste of waters.

Doubtless the imaginative mind of the period must have chafed under these restrictions of geographical knowledge; and now and again a more daring navigator must have pressed out beyond the limits of safety, into the Unknown, never to return. Once at least, even in the old Egyptian days, a band of navigators surpassing in daring all their predecessors, and their successors of the ensuing centuries, made bold to continue their explorations along the coast of Africa till they had passed to a region where—as Herodotus relates with wonder—the sun appeared "on their right hand," ultimately passing about the southern extremity of the African continent and in due course completing the circumnavigation, returning with wonder tales to excite the envy, perhaps, but not the emulation of their fellows.

Then in due course some Phœnician or Greek navigators coasted along the northern shores beyond the "Pillars of Hercules" and discovered at the very confines of the world what we now term the British Isles. But this was the full extent of exploration throughout antiquity; and the spread of civilization about the borders of the known world was a slow and haphazard procedure during all those centuries that mark the Classical and Byzantine periods.

THE MARINER'S COMPASS

The change came with that revival of scientific learning which was to usher in the new era that we speak of as modern times. And here as always it was a practical mechanism that gave the stimulus to new endeavor. In this particular case the implement in question was the mariner's compass, which consists, in its essentials, as everyone is aware, of a magnetized needle floated or suspended in such a way that it is made under the influence of terrestrial magnetism to point to the north and south.

The mysterious property whereby the magnetized needle obeys this inscrutable impulse is, in the last analysis, inexplicable even to the science of our day. But the facts, in their cruder relations, had been familiar from time immemorial to a nation whose habitat lay beyond the ken of the classical world—namely, the Chinese. It seems to be fairly established that navigators of that nation had used the magnetized needle, so arranged as to constitute a crude compass, from a period possibly antedating the Christian Era. To Western nations, however, the properties of the magnetized needle seem to have been quite unknown—at least its possibilities of practical aid to the navigator were utterly unsuspected—until well into the Middle Ages. There is every reason to believe—though absolute proof is lacking—that a knowledge of the compass came to the Western world from the Far East through the medium of the Arabs. The exact channel of this communication will perhaps always remain unknown. Nor have we any clear knowledge as to the exact time when the all-important information was transmitted. We only know that manuscripts of the twelfth century mentioned the magnetic needle as an implement familiar to navigators, and from this time forward, we may feel sure, the new possibilities of exploration made possible by the compass must have suggested themselves to some at least of the more imaginative minds of each generation. Indeed there were explorers in each generation who pushed out a little into the unknown, as the discovery of various groups of Islands in the Atlantic shows, although the efforts of these pioneers have been eclipsed by the spectacular feat of Columbus.

The exact steps by which the crude compass of the Orientals was developed into the more elaborate and delicate instrument familiar to Western navigators cannot be traced by the modern historian. It is known that sundry experiments were made as to the best form of needle, and in

particular as to the best way of adjusting it on approximately frictionless bearings. But a high degree of perfection in this regard had been attained before the modern period; and the compass had been further perfected by attaching the needle to a circumferential card on which the "points of the compass," thirty-two in number, were permanently marked. At all events the compass card had been so divided before the close of the fourteenth century, as is proved by a chance reference by Chaucer. The utility of the instrument thus perfected—indeed its entire indispensableness—was doubtless by this time clearly recognized by all navigators; and one risks nothing in suggesting that without the compass no such hazardous voyage into the unknown as that of Columbus would ever have been attempted.

9

No doubt the earliest observers of the needle believed that it pointed directly to the North. If such were indeed the fact the entire science of navigation would be vastly simpler than it is. But it required no very acute powers of observation to discover that the magnetized needle does not in reality point directly towards the earth's poles. There are indeed places on the earth where it does so point, but in general it is observed to deviate by a few degrees from the exact line of the meridian. Such deviation is technically known as magnetic declination. That this declination is not the same for all places was discovered by Columbus in the course of his first transatlantic voyage.

A century or so later, the accumulated records made it clear that declination is not a fixed quantity even at any given place. An Englishman, Stephen Burrows, is credited with making the discovery that the needle thus shifts its direction slightly with the lapse of time, and the matter was more clearly determined a little later by Gillebrand, Professor of Geometry at Graham College. Dr. Halley, the celebrated astronomer—whose achievements have been recalled to succeeding generations by the periodical return of the comet that bears his name—gave the matter attention, and in a paper before the Royal Society in 1692 he pointed out that the direction of the needle at London had changed in a little over a century (between 1580 and 1692) from 11 degrees 15 minutes East to 6 degrees West, or more than 17 degrees.

10

Halley conclusively showed that similar variations occurred at all other places where records had been kept. He had already demonstrated, a few years earlier, that the deviations of the compass noted at sea are not due to the varying attractions of neighboring bodies of land, but to some influence having to do with the problem of terrestrial magnetism in its larger aspects. Halley advocated the doctrine, which had first been put forward by William Gilbert, that the earth itself is a gigantic magnet, and that the action of the compass is dependent upon this terrestrial source and not, as many navigators believed, on the influence of a magnetic star, or on localized deposits of lodestone somewhere in the unknown regions of the North.

Further observations of the records presently made it clear that there are also annual and even daily variations of the compass of slight degree. The fact of diurnal variations was first discovered by Mr. Graham about the year 1719. More than half a century later it was observed by an astronomer named Wales, who was accompanying Captain Cook on his famous voyage round the world (1772-74), that there is yet another fluctuation of the compass due to the influence of the ship on which it is placed. Considerable quantities of iron were of course used in the construction of wooden ships, and it was made clear that the ship itself comes under the influence of the earth's magnetism and exerts in turn an appreciable influence on the compass. The fluctuation due to this source is known as deviation, in contradistinction to the larger fluctuation already referred to as declination.

11

Not only is the deviation due to the ship's influence a matter of importance, but it was discovered by Captain Matthew Flinders, in the course of his explorations along the coast of New Holland in the year 1801-02, that the influence of the ship over its compass varies with the direction of the ship's prow.

Needless to say, the problem of the deviation of the compass due to the influence of the ship is enormously complicated when the ship instead of being constructed chiefly of wood is made of iron or steel. It then becomes absolutely essential that the influence of vessels shall be reckoned with and so far as possible compensated. Such compensation may be effected by the adjustment of bodies of iron, as first suggested by Barlow, or by the use of permanent magnets, as first attempted by England's Astronomer Royal, Professor Airy. At the very best, however, it is never possible totally to overcome the ship's perverting influence, allowance for which must be made if an absolutely accurate conclusion is to be drawn from the record presented by the compass.

Early in the twentieth century an American ship, christened the *Carnegie*, in honor of the philanthropist who supplied funds for the enterprise, was constructed for the express purpose of making accurate charts of the lines of magnetic declination in various parts of the globe. This ship differs from every other vessel of considerable size ever hitherto constructed in that no magnetic material of any kind was used in connection with its structure or equipment. For the most part iron was substituted by copper or other non-magnetic metal. Pins of locust-wood largely took the place of nails; and wherever it was not feasible to do away with iron altogether it was used in the form of non-magnetic manganese steel. The purpose of the *Carnegie* is to provide accurate charts of magnetic declination for the use of navigators in general. The value of observations made with this non-magnetic ship will be clear when it is reflected that with an ordinary ship the observer can never be absolutely certain as to what precise share of the observed fluctuation of the compass is due at any given moment to the ship's influence. In other words—using technical terminology—he can never apportion with absolute accuracy the influence of declination and of deviation. Yet it is highly important that he should be able to do so, inasmuch as the declination of the compass is an all-important element in reckoning the exact location of the ship, and would be the same for every ship at that place, whereas deviation

12

denotes a purely local disturbance which would never be the same for any two ships of different construction.

Not only does the magnetized needle thus tend to vary in the direction of its horizontal action, but it also tends when suspended at the middle to shift its vertical axis. In regions near the equator, indeed, the magnetized needle maintains a horizontal position, but if carried into northern or southern latitudes it progressively "dips," its polar end sinking lower and lower. This dipping of the needle seems to have been first observed by Robert Norman, an English nautical instrument maker, about the year 1590. It was brought to the attention of Gilbert and carefully tested by him in the course of his famous pioneer experiments. Gilbert was led to predicate the existence of magnetic poles, the exact location of which would be indicated by the dipping needle, which, sinking lower and lower as northern latitudes were attained, would ultimately at the magnetic pole itself assume a vertical direction.

That this is a correct expression of the facts was determined in the year 1831 by Sir James Ross, who in the course of his Arctic explorations observed the vertical dip and so located the northern magnetic pole at about 70 degrees 5 minutes north latitude and 96 degrees 43 minutes west longitude. It was thus proved that the magnetic pole is situated a long distance—more than 1,200 miles—from the geographical pole. The location of the south magnetic pole was most accurately determined in 1909 by Lieutenant Shackleton's expedition at about 73 degrees south latitude and 156 degrees east longitude. The two magnetic poles are thus not directly opposite each other on the earth's surface, and the magnetic axis of the earth does not coincide with the geographical center of the globe itself.

From the standpoint of practical navigation the dip of the needle is a matter of much less significance than its horizontal fluctuations. Robert Norman himself attempted to overcome the dip by a balancing apparatus applied to the needle; and the modern compass is suspended in such a way that the propensity to dip does not interfere with the lateral movements which supply the navigator with all important information. The modern compass in question is the invention of Lord Kelvin and was patented by him in 1876. It consists of a number of small magnets arranged in parallel and held in position by silk threads, each suspended, cobweb-like, from the circular rim of aluminum. The weight—which in the aggregate is relatively slight—being thus largely at the circumference, the instrument has a maximum period of oscillation and hence a high degree of stability. Its fluctuations due to the ship's influence are corrected by a carefully adjusted disposition of metal balls and magnets.

SAILING BY DEAD RECKONING

While the compass gives indispensable information as to direction, and is constantly under the eye of the pilot, it of course can give no direct information as to the distance traversed by the ship, and hence does not by itself suffice to tell the navigator his whereabouts. In the early days there was indeed an expectation that the observed declination of the compass would reveal to the navigator his longitude and that the observation of the dip might enable him to determine his latitude. But more extended observation shows that this was asking altogether too much of the compass, and while it may be useful as an accessory it is by no means the navigator's chief reliance in determining his location. This is accomplished, as everyone is aware, in clear weather by the observation of the heavenly bodies. In cloudy weather, however, such observations obviously cannot be made, and the seaman must direct his ship and estimate his location—an all important matter when he is approaching the coast—by what is called dead reckoning. One element of this reckoning is furnished by the compass, inasmuch as that is his sole guide in determining the direction of the ship's progress. The other element is supplied by the log which furnishes him a clue as to the distance traversed hour by hour.

It is rather startling to reflect that the navigators of the middle ages had no means whatever of determining the rate of progress of a ship at sea, beyond the crudest guesses unaided by instrument of any kind. When Columbus made his voyage he had no means of knowing what distance he had actually sailed; nor was any method of measuring the ship's speed utilized throughout the course of the ensuing century. In the year 1570, however, one Humfray Cole suggested a theoretical means of measuring the ship's rate of progress by means of an object dropped back of the ship and allowed to drag through the water; and this suggestion led a generation later to the introduction of the log, which was first actually tested, so far as can be learned, in the year 1607.

The original log was so called because it consisted essentially of an actual log or piece of wood. To the center of this a string was attached, and in testing the ship's rate of progress this string was allowed to slip through the fingers of a sailor who counted the number of knots—placed, of course, at regular intervals on the string—that passed through his fingers in a given time. As the log itself would remain practically stationary in the water where it was dropped, the number of knots counted indicated the distance traversed by the ship in a given time. In practice the time was usually gauged by a half-minute sand glass, and the knots were arranged at such a distance on the cord that, in the course of the half minute, one knot would pass through the fingers for each nautical mile covered by the ship in an hour. The actual distance between the knots was therefore about fifty feet. The nautical or geographical mile represents one degree of the earth's circumference at the equator, amounting therefore to 6,008 feet, as against the 5,280 feet of the statute mile. It was the use of the log-line with its knots, as just explained, that led to the dubbing of the nautical mile by the name "knot," which is still familiarly employed, though the

knotted log-line itself has been superseded in recent times, except on very old-fashioned sailing ships.

The log retains its place even in the most modern ship, though its form is materially altered, and its importance is somewhat lessened owing to the fact that the experienced skipper can test the speed of his ship very accurately by noting the number of revolutions per minute of the ship's propellers. It is indeed the ship's propeller that supplies the model for the modern log, in which the primitive piece of wood is replaced by a torpedo-like piece of metal with miniature propeller-like blades at its extremity. This apparatus is towed at the end of a long line, and its blades, whirling more or less rapidly according to the speed of the ship, communicate their motion to a recording apparatus, adjusted at the ship's stern, to which the line is attached and the face of which ordinarily presents a dial on which the speed of the ship may be observed as readily as one observes the time by the clock.

17

Some recent modifications of the log employ an electrical device to register the progress, but the principle of the revolving vanes, which owe their speed to the rate at which they are dragged through the water, is the fundamental one upon which the action of the log usually depends, though attempts have been made to substitute pressure-gauge systems.

While the modern log records the speed of the ship with a fair degree of accuracy, its register shows at best only an approximation of the facts. As already mentioned, the rate of revolution of the ship's propeller blades furnishes what most navigators regard as a rather more dependable test of speed. An apparatus for recording this is found on the bridge of the modern ship. But due allowance must of course be made for the effect of winds, waves, and ocean currents. These constantly variable factors obviously make the estimate as to the precise distance traversed by a ship in a given time a matter not altogether devoid of guess work; and no navigator who has been obliged to sail for several days by dead reckoning approaches a coast with quite the same degree of satisfaction that he may entertain if his log has been checked by observation of the sun or stars. In case, however, a navigator is able to check his reckoning by astronomical observations, aided by the chronometer, he determines his location with great accuracy.

18

THE DEVELOPMENT OF THE SEXTANT

The instrument with which such astronomical observations are made is known as the sextant. Its purpose is to measure with great accuracy the angle between two objects, which in practice are the horizon line on one hand and some celestial body, usually the sun, on the other. The determination of the latitude of the ship, for example, is a matter of comparative ease, if the sun chances to be unobscured just at midday. The navigator has merely to measure the exact elevation of the sun as it crosses the meridian,—that is to say when it is at its highest point,—and, having made certain corrections for so-called dip and refraction, to which we shall refer more at length in a moment, a very simple calculation reveals the latitude—that is to say, the distance from the terrestrial equator.

That the latitude of a ship could thus be determined, with greater or less accuracy, has been familiar knowledge to seamen from a very early period. It was by the use of this principle that the earth was measured by Eratosthenes and Posidonius in classical times, and the sailors of antiquity probably carried with them a crude apparatus for measuring the height of sun and stars, as the mediæval navigators are known to have done.

19

The simplest and crudest form of measurer of which the record has been preserved is known as the cross-staff. This consisted essentially of a stick about a yard in length, called the staff, on which a cross-piece was arranged at right angles, so adjusted at the center as to slide back and forth on the staff. An eye-piece at one end of the staff was utilized to sight along projections at either end of the cross-piece. If the apparatus is held so that one of the lines of sight is directed to the horizon, and then the cross-piece slid along the staff until the other line of sight is directed toward the sun or a given star, the angle between the two lines of sight will obviously represent the angle of altitude of the celestial body in question. But the difficulty of using an apparatus which requires two successive observations to be made without shift of position is obvious, and it is clear that the information derived from the cross-staff must have been at best very vague—by no means such as would satisfy the modern navigator.

Even the navigators of the fifteenth century were aware of the deficiencies of the cross-staff and sought to improve upon it. The physicians of Henry the Navigator of Portugal, Roderick and Joseph by name, and another of his advisers, Martin de Bohemia, are credited with inventing, or at least introducing, a much improved apparatus known as the astrolabe. This consists of a circle of metal, arranged to be suspended from a ring at the side, so that one of its diameters would maintain the horizontal position through the effect of gravity. A superior quadrant of the circle was marked with degrees and minutes. A straight piece of metal, with sights so that it could be accurately pointed, was adjusted to revolve on a pivot at the center of the circle. This sighting piece being aimed at the sun, for example, the elevation of that body could be read directly on the measuring arc of the circle. Here, then, was no new principle involved, but the instrument had obvious points of advantage over the cross-staff, in particular because only a single sight need be taken, the horizon line being determined, as already explained, through the action of gravitation.

20

The astrolabe did not gain immediate favor with practical navigators, and it was at best a rather clumsy instrument, subject to peculiar difficulties when used on a rolling ship. Many

attempts were made to improve upon it, but for a long time none of these was altogether successful. The final suggestion as to means of overcoming the difficulties encountered in measuring the altitude of astronomical bodies was made by Sir Isaac Newton. But nothing practical came of his discovery, as it was not published until a long time after his death. Meantime independent discovery of the same principle was made by Thomas Godfrey of Philadelphia, in 1730, and by the English astronomer Hadley, who published his discovery before the Royal Society in 1731. The instrument which Hadley devised was called a quadrant. The principle on which it worked involved nothing more complex than the use of two mirrors, one of them (known as the horizon glass and having only half its surface mirrored) fixed in the line of vision of a small telescope; the other (called the index mirror) movable with the arm of an indicator, which is so adjusted as to revolve about the axis of the quadrant. In operation these two mirrors enable the images of two objects, the distance between which is to be measured, to be superimposed. The telescope may be pointed at the horizon, for example, directly under the position of the sun, and the arm of the instrument, altering the position of the so-called index mirror, may be rotated until the limb of the sun seems just to touch the horizon—the latter being viewed through the unsilvered half of the horizon glass. The scale at the circumference of the instrument is marked in half-degrees, which, however, are registered as whole degrees, and which, so interpreted, give the direct measurement of the angular distance between the horizon and the sun; in other words the measurement of the sun's altitude or so-called declination.

The instrument just described, perfected as to details but not modified as to principles, constitutes the modern sextant, which is used by every navigator, and which constitutes, along with the compass and chronometer, the practical instrumental equipment that enables the seaman to determine—by using the tables of the *Nautical Almanac*—his exact position on the earth's surface from observation of the sun or certain of the fixed stars. The modern instrument is called a sextant because it has, for convenience' sake, been restricted in size to about one-sixth of a circle instead of the original one-quarter, the small size being found to answer every practical purpose, since it measures all angles up to 120 degrees.

In practice the sextant is an instrument only six or eight inches in diameter. It is held in the right hand and the movable radial arm is adjusted with the left hand with the aid of a micrometer screw, and the reading of the scale is made accurate by the vernier arrangement. The ordinary observation—which every traveler has seen a navigator make from the ship's bridge just at midday—is carried out by holding the sextant in a vertical position directly in line of the sun, and sighting the visible horizon line, meantime adjusting the recording apparatus so as to keep the sun's limb seemingly in touch with the horizon. As the sun is constantly shifting its position the vernier must be constantly adjusted until the observation shows that the sun is at the very highest point. The instrument being clamped and the scale read, the latitude may be known when proper correction has been made for the so-called dip, for refraction, and where great accuracy is required for parallax.

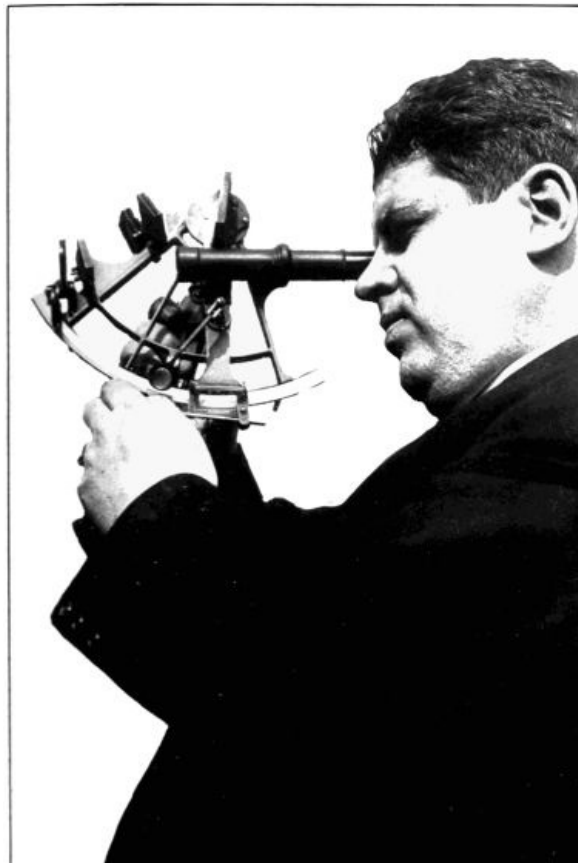

"TAKING THE SUN" WITH THE SEXTANT.

The instrument is held in the right hand, and levelled at the horizon; the left hand manipulating the micrometer screw which adjusts the radial arm

carrying the index mirror (at top of figure). The result is read on the Vernier scale (arc at bottom of figure) with the aid of the magnifying glass.

Dip, it may be explained, is due to the fact that the observation is made not from the surface of the water but from an elevation, which is greater or less according to the height of the bridge, and which therefore varies with each individual ship. The error of refraction is due to the refraction of the sun's light in passing through the earth's atmosphere, and will vary with the temperature and the degree of atmospheric humidity, both of which conditions must be taken into account. The amount of refractive error is very great if an object lies near the horizon. Everyone is familiar with the oval appearance of the rising or setting sun, which is due to refraction. With the sun at the meridian, the refractive error is comparatively slight; and when a star is observed at the zenith the refractive error disappears altogether.

23

By parallax, as here employed, is meant the error due to the difference in the apparent position of the sun as viewed by an observer at any point of the earth's surface from what the apparent position would be if viewed from the line of the center of the earth, from which theoretical point the observations are supposed to be made. In the case of bodies so distant as the sun, this angle is an exceedingly minute one, and in the case of the fixed stars it disappears altogether. The sun's parallax is very material indeed from the standpoint of delicate astronomical observations, but it may be ignored altogether by the practical navigator in all ordinary observations. There is one other correction that he must make, however, in case of sun observations; he must add, namely, the amount of semi-diameter of the sun to his observed measurement, as all calculations recorded in the *Nautical Almanac* refer to the center of the sun's disk.

PERFECTING THE CHRONOMETER

The observation of the sun's height, with the various corrections just suggested, suffices by itself to define the latitude of the observer. Something more is required, however, before he can know his longitude. How to determine this, was a problem that long taxed the ingenuity of the astronomer. The solution came finally through the invention of the chronometer, which is in effect an exceedingly accurate watch.

24

Time measurers of various types have, of course, been employed from the earliest times. The ancient Oriental and Classical nations employed the so-called clepsydra, which consisted essentially of receptacles from or into which water dripped through a small aperture, the lapse of time being measured by the quantity of water. At an undetermined later date sand was substituted for the water, and the hour glass with which, in some of its forms, nearly everyone is familiar, came into use. For a long time this remained a most accurate of time measurers, though efforts were early made to find substitutes of greater convenience. Then clocks operated by weights and pulleys were introduced; and, finally, after the time of the Dutchman Huygens, the pendulum clock furnished a timepiece of great reliability. But the mechanism operated by weight or pendulum is obviously ill-adapted to use on shipboard. Portable watches, in which coiled springs took the place of the pendulum, had indeed been introduced, but the mechanical ingenuity of the watchmaker could not suffice to produce very dependable time-keepers. The very idea of a watch that would keep time accurately enough to be depended upon for astronomical observations intended to determine longitude was considered chimerical.

Nevertheless the desirability of producing a portable time-keeper of great accuracy was obvious, and the efforts of a large number of experimenters were directed towards this end in the course of the eighteenth century. These efforts were stimulated by the hope of earning a prize of twenty thousand pounds offered by the British Government for a watch sufficiently accurate to determine the location of a ship with maximum error of half a degree, or thirty nautical miles, corresponding to two minutes of time, in the course of a transatlantic voyage. It affords a striking illustration of the relative backwardness of nautical science, and of the difficulties to be overcome, to reflect that no means then available enabled the navigator at the termination of a transatlantic voyage to be sure of his location within the distance of thirty nautical miles by any means of astronomical or other observation known to the science of the time.

25

The problem was finally solved by an ingenious British carpenter named John Harrison, who devoted his life to the undertaking, and who came finally to be the most successful of watchmakers. Harrison first achieved distinction by inventing the compensating pendulum—a pendulum made of two metals having a different rate of expansion under the influence of heat, so adjusted that change in one was compensated by a different rate of change in the other. Up to the time of this discovery, even the best of pendulum clocks had failed of an ideal degree of accuracy owing to the liability to change of length of the pendulum—and so, of course, to corresponding change in the rate of its oscillation—with every alteration of temperature. Another means of effecting the desired compensation was subsequently devised by Mr. Graham, through the use of a well of mercury in connection with the pendulum, so arranged that the expansion of the mercury upward in its tube would compensate the lengthening of the pendulum itself under effect of heat, and vice versa; but the Harrison pendulum, variously modified in design, remains in use as a highly satisfactory solution of the problem.

26

Harrison early conceived the idea that it might be possible to apply the same principle to the balance-wheel of the watch. This problem presented very great practical difficulties, but by

persistent effort these were finally overcome, and a balance-wheel produced, which, owing to the unequal expansion and contraction of its two component metals under changing temperature, altered its shape and so maintained its rate of oscillation almost—though never quite—regardless of changing conditions of temperature.

In 1761 Harrison produced a watch which was tested on a British ship in a trip to the West Indies in that and the succeeding year, and which proved to be a time-keeper of hitherto unexampled accuracy. The inventor had calculated that the watch, when carried into the tropics, would vary its speed by one second per day with each average rise of ten degrees of temperature. Making allowance for this predicted alteration, it was found that the watch was far within the limits of variation allowed by the conditions of the test above outlined. It had varied indeed only five seconds during the journey across the ocean. On the return trip the watch was kept in a place near the stern of the ship, for the sake of dryness, where, however, it was subjected to a great deal of joggling, which led to a considerably greater irregularity of action; but even so its variation on reaching British shores was such as to cause a maximum miscalculation of considerably less than thirty nautical miles.

27

Although Harrison seemed clearly enough to have won the prize, there were influences at work that interfered for a time with full recognition of his accomplishment. Presently he received half the sum, however, and ultimately, after having divulged the secret of his compensating balance and proved that he could make other watches of corresponding accuracy, he received the full award.

Minor improvements have naturally been made in the watch since that time, but the essential problem of making a really reliable portable timepiece was solved by the compensating balance-wheel of Harrison. The ship's chronometer of to-day is merely a large watch, with an escapement of particular construction, mounted on gimbals so that it will maintain a practically horizontal position.

Modern ships are ordinarily provided with at least three of these time-keepers in order that each may be compared with the others, and a more accurate determination of the time made than would be possible from observation of a single instrument; inasmuch as no absolutely accurate time-keeper has ever been constructed. Two chronometers would obviously be not much better than one, since there would be no guide as to whether any variation between them had been caused by one running too fast or the other too slowly. But with a third chronometer to check the comparison, it is equally obvious that a dependable clue will be given as to the exact time.

28

It is to be understood of course that the variation of any of the chronometers will be but slight if they are good instruments. Moreover the tendency to vary in one direction or the other of each individual instrument will be known from previous tests. Such tests are constantly made at the Royal Observatory in England and elsewhere, and the best chronometers bear certificates as to their accuracy and as to their rate of variation. It may be added that a chronometer or other timepiece is technically said to be a perfect instrument, not when it has no variation at all—since this has proved an unattainable ideal—but when its variation is slight, is always in one direction, and is perfectly or almost perfectly uniform.

FINDING THE TIME WITHOUT A CHRONOMETER

In the reference made above to the testing of Harrison's watch, it was stated that that instrument varied by only a certain number of seconds in the course of the westerly voyage across the Atlantic, and that its variation was somewhat greater on the return voyage. This implies, clearly, that some method was available to test the watch in the West Indies, without waiting for the return to England. At first thought this may cause no surprise, since the local time can of course be known anywhere through meridian observations; but on reflection it may seem less and less obvious as to just what test was available through which the exact difference in time between Greenwich, at which the watch was originally tested, and local time at the station in the West Indies could be determined. There are, however, several astronomical observations through which this could be accomplished, and in point of fact the comparative times and hence the precise longitudes at many points on the Western Hemisphere—and indeed of all portions of the civilized globe—were accurately known before the day of the chronometer.

29

One of the simplest and most direct means of testing the time of a place, as compared with Greenwich time, is furnished by observation of the occultation of one of the moons of Jupiter. By occultation is meant, as is well known, the eclipse of the body through passing into the shadow of its parent planet. This phenomenon, causing the sudden blotting out of the satellite as viewed from the earth, occurs at definite and calculable periods and is obviously quite independent of any terrestrial influence. It occurs at a given instant of time and would be observed at that instant by any mundane witness to whom Jupiter was at that time visible. If then an observer noted the exact local time at which occultation occurred, and compared this observed time with the Greenwich time at which such occultation was predicted to occur, as recorded in astronomical tables, a simple subtraction or addition will tell him the difference in time between his station and the meridian at Greenwich; and this difference of time can be translated into degrees of longitude by merely reckoning fifteen degrees for each hour of time, and fractions of the hour in that proportion.

30

It will be noted that this observation has value for the purpose in question only in conjunction

with certain tables in which the movements of Jupiter and its satellite are calculated in advance. This is equally true of the various other observations through which the same information may be obtained—as for example, the observation of a transit of Mars, or the measurement of apparent distance between the moon and a given fixed star. Before the tables giving such computations were published it was quite impossible to determine the exact longitude of any transatlantic place whatsoever. We have already pointed out that Columbus had only a vague notion as to how far he had sailed when he discovered land in the West. The same vagueness obtained with all the explorations of the immediately ensuing generations.

It was not until about the middle of the sixteenth century that Mercator and his successors brought the art of map-making to perfection; and the celebrated astronomical tables of the German Mayer, which served as the foundation for calculations of great importance to the navigator, were not published until 1753. The first *Nautical Almanac*, in which all manner of astronomical tables to guide the navigator were included, was published at the British Royal Observatory in 1767.

At the present time, a navigator would be as likely to start on a voyage without compass and sextant as without charts and a *Nautical Almanac*. Indeed were he to overlook the latter the former would serve but a vague and inadequate purpose. Yet, as just indicated, this invaluable adjunct to the equipment of the navigator was not available until well toward the close of the eighteenth century. But of course numerous general tables had been in use long before this, else—to revert to the matter directly in hand—it would not have been possible to make the above-recorded test in the case of Harrison's famous watch in the voyage of 1761-62.

31

ASCERTAINING THE SHIP'S LONGITUDE

In the days before the chronometer was perfected, almost numberless methods of attempting to determine the longitude of a ship at sea were suggested. There were astronomers who advocated observation of the eclipse of Jupiter's satellites; others who championed the method of so-called lunars—that is to say, calculation based on observation of the distance of the moon at a given local time from one or another of certain fixed stars arbitrarily selected by the calculator. Inasmuch as the seaman could always regulate even a faulty watch from day to day by observation of the meridian passage of the sun, it was thought that these observations of Jupiter's satellite or of the moon would serve to determine Greenwich time and therefore the longitude at which the observation was made with a fair degree of accuracy. But in practice it is not easy to observe the eclipse of Jupiter's satellite without a fair telescope; and it was soon found that the tables for calculating the course of the moon were by no means reliable, hence theoretically excellent methods of determining longitude by observation of that body proved quite unreliable in practice.

32

It was with the chief aim of bettering our knowledge of the moon's course through long series of very accurate observations that the Royal Observatory at Greenwich was founded. Perhaps it was not unnatural under these circumstances that certain of the Astronomers Royal should have advocated the method of lunars as the mainstay of the navigator. In particular Maskelyne, who was in charge of the Observatory in the latter part of the eighteenth century, was so convinced of the rationality of this method that he was led to discredit the achievements of Harrison's watches, and for a long time to exert an antagonistic influence, which the watchmaker resented bitterly and it would appear not without some show of reason.

Ultimately, however, the accuracy of the watch, and its indispensableness in the perfected form of the chronometer, having been fully demonstrated, the method of lunars became practically obsolete and the mariner was able to determine his longitude with the aid of sextant, chronometer, and *Nautical Almanac*, by means of direct observation of the altitude of the sun by day and of sundry fixed stars by night, a much simpler calculation sufficing than was required by the older method.

As the sun is the chief time-measurer, whose rate of passage in a seeming circumnavigation of the heavens is recorded by the dial of clock, watch, or chronometer, it would seem as if the simplest possible method of determining longitude would be found through observation of the sun's meridian passage. The user of the sextant on shipboard always makes, if weather permits, a meridian observation of the sun, and such observation gives him an accurate gauge of the altitude of the sun at its highest point and hence of his own latitude. By adjusting the arm of the sextant with which this observation is made, the observer is able to determine the exact point reached by the sun in its upward course with all requisite accuracy.

33

But, unfortunately for his purpose, the sun does not poise for an instant at the apex of its upward flight and then begin its descent. On the contrary, its orbit being circular, the course of the sun just at its highest point is approximately horizontal for an appreciable length of time, and while the observer therefore has adequate opportunity to measure with accuracy the highest point reached, he cannot possibly make sure, within the limits of a considerable fraction of a minute, as to the precise moment when the center of the sun is on the meridian. He can, indeed, determine this point with sufficient accuracy for rough calculations, but modern navigation demands something more than rough calculations, inasmuch as a variation in time of one minute represents one-quarter of a degree of longitude, or fifteen nautical miles at the equator, and such uncertainty as this would imply can by no means be permitted in the safe navigation of a ship that may be passing through the water at the rate of a nautical mile in less than three minutes.

It follows that meridian observation of the sun, owing to the necessary inaccuracy of such observation, is not the ideal method. In point of fact the sun may be observed for this purpose to much better advantage when it is at a considerable distance from the meridian, since then its altitude above the horizon at a given moment is the only point necessary to be determined. The calculation by which the altitude of the sun may be translated into longitude is indeed more complicated in this case; but while spherical trigonometry is involved in the calculation, the tables supplied by the *Nautical Almanac* enable the navigator to make the estimate without the use of any knowledge beyond that of the simplest mathematics.

MEASURING A DEGREE OF LATITUDE

While these observations tell the navigator his exact location in degrees of latitude and longitude, such knowledge does not of course reveal the distance traversed unless the precise length of the degree itself is known; and this obviously depends upon the size of the earth. Now we have seen that the earth was measured at a very early date by Greek and Roman astronomers, but of course their measurements, remarkable though they were considering the conditions under which they were made, were but rough approximations of the truth. Numerous attempts were made to improve upon these early measurements, but it was not until well into the seventeenth century that a really accurate measurement was made between two points on the earth's surface, the difference between which, as measured in degrees and minutes, was accurately known.

In June of the year 1633, the Englishman Robert Norman made very accurate observations of the altitude of the sun on the day of the summer solstice (when of course it is at its highest point in the heavens); the observation being made with a quadrant several feet in diameter stationed at a point near the Tower of London. On the corresponding day of the following year he made similar observations at a point something like 125 miles south of London, in Surrey. The two observations determined the exact difference in latitude between the two points in question.

Norman then undertook a laborious survey, that he might accurately measure the precise distance in miles and fractions thereof that corresponded to these known degrees of latitude. He made actual measurements with the chain for the most part, but in a few places where the topography offered peculiar difficulties he was obliged to depend upon the primitive method of pacing.

The modern surveyor, equipped with instruments for the accurate measuring of angles, not differing largely in principle from the quadrant of the navigator, would consider Norman's method of measurement a very clumsy one. He would measure only a single original base line of any convenient length, but would make that measurement with very great accuracy, using, perhaps, a rod packed in ice that it might not vary in length by even the fraction of an inch through changes in temperature. An accurate base line thus secured, he would depend thereafter on the familiar method of triangulation, in which angles are measured very accurately, and from such measurement the length of the sides of the successive triangles determined by simple calculation. In the end he would thus have made the most accurate determination of the distance involved, without having actually measured any portion thereof except the original base line. Notwithstanding the crudity of Norman's method, however, his estimate of the actual length of a degree of the earth's surface was correct, as more recent measurements have demonstrated, within twelve yards—a really remarkable result when it is recalled that the total length of the degree is about sixty nautical miles.

Inasmuch as the earth is not precisely spherical, but is slightly flattened at the poles, successive degrees of latitude are not absolutely uniform all along a meridian, but decrease slightly as the poles are approached. The deviation is so slight, however, that for practical purposes the degree of latitude may be considered as an unvarying unit. But obviously such is not the case with a degree of longitude. The most casual glance at a globe on which the meridian lines are drawn, shows that these lines intersect at the poles, and that the distance between them is, in the nature of the case, different at each successive point between poles and equator. It is only at the equator itself that a degree of longitude represents $1/360$ of the earth's circumference. Everywhere else the parallels of latitude cut the meridians in what are termed small circles—that is to say, circles that do not represent circumference lines in the plane of the earth's center. Therefore while all points on any given meridian of longitude are equally distant in terms of degrees and minutes of arc from the meridian of Greenwich, the actual distances from that meridian of the different points as measured in miles will depend entirely upon their latitude.

At the equator each degree of longitude corresponds to (approximately) sixty miles, but in the middle latitudes traversed for example by the transatlantic lines, a degree of longitude represents only half that distance; and in the far North the meridians of longitude draw closer and closer together until they finally converge, and at the poles all longitudes are one.

It follows, then, that the navigator must always know both his latitude and his longitude in order to estimate the exact distance he has sailed. We have seen that a single instrument, the sextant, enables him to make the observations from which both these essentials can be determined. We must now make further inquiry as to the all important guide without the aid of which his observations, however accurately made, would avail him little. This guide, as already pointed out, is found in the set of tables known as the *Nautical Almanac*.

Had the earth chanced to be poised in space with its axis exactly at right angles to its plane of revolution, many computations of the astronomer would be greatly simplified. Again, were the planetary course circular instead of elliptical, and were the earth subject to no gravitational influences except that of the sun and moon, matters of astronomical computation would be quite different from what they are. But as the case stands, the axis of the earth is not only tipped at an angle of about twenty-three degrees, but is subject to sundry variations, due to the wobbling of the great top as it whirls.

38

Then the other planets, notably the massive Jupiter, exert a perverting influence which constantly interferes with the regular progression of the earth in its annual tour about the sun. A moment's reflection makes it clear that the gravitation pull of Jupiter is exerted sometimes in opposition to that of the sun, whereas at other times it is applied in aid of the sun, and yet again at various angles. In short, on no two successive days—for that matter no two successive hours or minutes—is the perturbing influence of Jupiter precisely the same.

What applies to the earth applies also, of course, to the varying action of Jupiter on the moon and to the incessantly varied action of the moon itself upon the earth. All in all, then, the course of our globe is by no means a stable and uniform one; though it should be understood that the perturbations are at most very slight indeed as compared with the major motions that constitute its regular action and lead to the chief phenomena of day and night and the succession of the seasons.

Relatively slight though the perturbations may be, however, they are sufficient to make noteworthy changes in the apparent position of the sun and moon as viewed with modern astronomical instruments; and they can by no means be ignored by the navigator who will determine the position of his ship within safe limits of error. And so it has been the work of the practical astronomers to record thousands on thousands of observations, giving with precise accuracy the location of sun, moon, planets, and various stars at given times; and these observations have furnished the basis for the elaborate calculations of the mathematical astronomers upon which the tables are based that in their final form make up the *Nautical Almanac*, to which we have already more than once referred.

39

These calculations take into account the precise nature of the perturbing influences that are exerted on the earth and on the moon on any given day, and hence lead to the accurate prediction as to the exact relative positions of these bodies on that day. Stated otherwise, they show the precise position in the heavens which will be held at any given time by the sun for example, or by the important planets, as viewed from the earth. How elaborate these computations are may be inferred from the statement that the late Professor Simon Newcomb used about fifty thousand separate and distinct observations in preparing his tables of the sun. Once calculated, however, these tables of Professor Newcomb are so comprehensive as to supply data from which the exact position of the sun can be found for any day between the years 1200 B.C. and 2300 A.D., a stretch of some thirty-five centuries.

Such a statement makes it clear how very crude and vague the deductions must have been from the observations of navigators, however accurately made, prior to the time when such tables as those of the *Nautical Almanac* had been prepared. Fully to appreciate this, it is necessary to understand that the observations supplied in such profusion for the use of the mathematical astronomer are in themselves subject to errors that might seriously vitiate the results of the final computation. They must, therefore, be made with the utmost accuracy, and with instruments specially prepared for the purpose. The chief of these instruments is not the gigantic telescope but the small and relatively simple apparatus known as a transit instrument. This constitutes essentially a small telescope poised on very carefully adjusted trunnions, in such a way that it revolves in a vertical axis, bringing into view any celestial body that is exactly on the meridian, and bodies in this position only. To make observation of the transit—that is to say the passage across the meridian line—of any given body more accurate, the transit instrument has stretched vertically across the center of its field of vision a spider web, or a series of parallel spider webs; in order, in the latter case, that the mean time of several observations may be taken.

40

So exceedingly difficult is it to manufacture and mount an instrument of requisite nicety of adjustment, that the effort has almost baffled the ingenuity of the mechanic. Sir George Airy, in making a transit instrument for use at the Royal Observatory at Greenwich, required the trunnions on which it was to be mounted to be ground truly cylindrical in form within a variation of one thirty-two-thousandth of an inch as determined by a delicate spirit level. Even when all but absolute decision has been obtained, however, it is quite impossible to maintain it, as the slightest variation of temperature—due perhaps to the application of the hand to one of the pillars on which the trunnions rest—may disturb the precise direction of the spider webs and so militate against absolute accuracy of observation. The instrument must, therefore, be constantly tested and its exact range of errors noted and allowed for.

41

To devote so much labor to details, merely in the effort to determine the precise moment at which a star or planet crosses the meridian, would seem to be an absurd magnification of trifles. But when we reflect that the prime object of such observations is to supply practical data which will be of service in enabling navigators on all the seas of the globe to bring their ships safely to port, the matter takes on quite another aspect. We have here, obviously, another and a very striking illustration of the close relationship that obtains between the work of the theoretical devotee of science and that of the practical man of affairs.

SOUNDINGS AND CHARTS

Though the navigator, thanks to his compass, sextant, and *Nautical Almanac*, may determine with a high degree of precision his exact location, yet even the best observations do not enable him to approach a coast without safeguarding his ship by the use of another piece of mechanism calculated to test the depth of the waters in which he finds himself at any given moment. In its most primitive form—in which form, by the bye, it is still almost universally employed—this apparatus is called the lead,—so called with much propriety because it consists essentially of a lump of lead or other heavy weight attached to a small rope. Knots in the rope enable the sailor who manipulates the lead to note at a glance the depth to which it sinks. Most ocean travelers have seen a sailor heaving the lead repeatedly at the side of the ship and noting the depth of the water, particularly as the ship approached the Long Island shore.

42

While this simple form of lead suffices for ordinary purposes, when the chief information sought is as to whether the water is deeper than the draft of the ship, it is at best only a rough and ready means of testing the depth in relatively shallow waters. For deeper waters and to test with greater accuracy the depths of uncharted regions, and in particular to determine the character of the sea bottom at any given place, more elaborate apparatuses are employed. One of the most useful of these is the invention of the late Lord Kelvin. In this the lead is replaced by a cannon ball, perforated and containing a cylinder which is detached when the weight reaches the bottom and is drawn to the surface filled with sand or mud, the cannon ball remaining at the bottom. In another form of patent lead, a float becomes detached so soon as the weight strikes the bottom and comes at once to the surface, thus recording the fact that the bottom has been reached,—a fact not always easy to appreciate by the mere feel of the line when the water is fairly deep.

43

It is obvious that however well informed the navigator may be as to his precise latitude and longitude, he can feel no safety unless he is equally well informed as to the depth of the water, the proximity of land, the presence or absence of shallows in the region, and the like. He must, therefore, as a matter of course, be provided with maps and charts on which these things are recorded. From the days when navigation first became a science, unceasing efforts have been made to provide such maps and charts for every known portion of the globe. Geographical surveys, with the aid of the method of triangulation, have been made along all coasts, and elaborate series of soundings taken for a long distance from the coast line, and there are now few regions into which a ship ordinarily sails, or is likely to be carried by accident, for which elaborate charts, both of coast lines and of soundings, have not been provided. The experienced navigator is able to direct his ship with safety along coasts that he visits for the first time, or to enter any important harbor on the globe without requiring the services of a local pilot,—albeit the desire to take no undue risk makes it usual to accept such services.

Time was, however, when maps and charts were not to be had, and when in consequence the navigator who started on his voyages of exploration was undertaking a feat never free from hazard. Until the time of Mercator there was not even uniformity of method among map makers in the charting of regions that had been explored. The thing seems simple enough now, thanks to the maps with which every one has been familiar since childhood. But it required no small exercise of ingenuity to devise a reasonably satisfactory method of representing on a flat surface regions that in reality are distributed over the surface of a globe. The method devised by Mercator, and which, as everyone knows, is now universally adopted, consists in drawing the meridians as parallel lines, giving therefore a most distorted presentation of the globe, in which the distance between the meridians at the poles—where in reality there is no distance at all—is precisely as great as at the equator. To make amends for this distortion, the parallels of latitude are not drawn equidistant, as in reality they practically are on the globe, but are spaced farther and farther apart, as we advance from the equator toward either pole. The net result is that an island in the arctic region would be represented on the map several times as large as an island actually the same size but located near the equator. Doubtless most of us habitually conceive Alaska and Greenland to be vastly more extensive regions than they really are, because of our familiarity with maps showing this so-called "Mercator's projection."

44

Of course maps are also made that hold to the true proportions, representing the lines of latitude as equidistant and the meridians of longitude as lines converging to a point at the poles. But while such a map as this has certain advantages—giving, for example, a correct notion of the relative sizes of polar and other land masses—it is otherwise confusing inasmuch as places that really lie directly in the north and south line cannot be so represented except just at the middle of the map, and it is very difficult for the ordinary user of the map to gain a clear notion as to the actual points of the compass. A satisfactory compromise may be effected, however, by using Mercator's projection for maps showing wide areas, while the other method is employed for local maps.

45

THE LURE OF THE UNKNOWN

While the average man, even with well developed traveling instincts, would perhaps prefer always to feel that he is sailing in well charted waters and along carefully surveyed coasts, there have been in every generation men who delighted in taking risks, and for whom half the charm of a voyage must always lie in its dangers. Such men have been the pioneers in exploring the new regions of the globe. That there was no dearth of such restless spirits in classical times and even

in the dark ages, records that have come down to us sufficiently attest. For the most part, however, their names have not been preserved to us. But since the ushering in of the period which we to-day think of as the beginning of modern times, records have been kept of all important voyages of discovery, and at least the main outlines of the story of the conquest of the zones are familiar to everyone.

Some of the earliest explorers, most notable among whom was the Italian Marco Polo, traveled eastward from the Mediterranean and hence journeyed largely by land. But soon afterward, thanks to the introduction of the compass,—which instrument Marco Polo has sometimes been mistakenly accredited with bringing from the East,—the adventurers began to cast longing eyes out toward the western horizons. Among the first conspicuous and inspiring results were the discoveries of the groups of islands known as the Cape Verdes and the Azores. The Canary Islands were visited by Spaniards even earlier, and became the subject of controversy with the other chief maritime nation of the period, the Portuguese.

46

When the controversy was adjusted the Spaniards were left in possession of the Canaries, but the Portuguese were given by treaty the exclusive right to explore the coast of Africa. Following up sundry tentative efforts, the daring Portuguese navigator, Bartholomeo Dias, in the year 1487, passed to the southern-most extremity of Africa, which he christened the Cape of Good Hope. At last, then, it had been shown that Africa did not offer an interminable barrier to the passage to the fabled land of treasures in the East. Before anyone had ventured to follow out the clues which the discovery of the Cape had presented, however, Columbus had seemingly solved the problem in another way by sailing out boldly into the West and supposedly coming to the East Indies in 1492.

The western route was barred to the Portuguese but the eastern one remained open to them, and before the close of the century Vasco da Gama had set out on the voyage that ultimately led him to India by way of the Cape (1497-1500 A.D.). Twenty years later another Portuguese navigator, Magellan by name, started on what must ever remain the most memorable of voyages, save only that of Columbus. Magellan rounded the southern point of South America and in 1521 reached the Philippines, where he died. His companions continued the voyage and accomplished ultimately the circumnavigation of the globe; and in so doing afforded the first unequivocal practical demonstration, of a character calculated to appeal to the generality of uncultured men of the time, that the world is actually round.

47

Two routes from Europe to the Indies had thus been established, but both of them were open to the objection that they necessitated long detours to the South. To the geographers of the time it seemed more than probable that a shorter route could be established by sailing northward and coasting along the shores either of Europe to the East or—what seemed more probable—of America to the West. Toward the close of the sixteenth century the ships of the Dutch navigators had penetrated to Nova Zembla, and a few years later Henry Hudson visited Spitzbergen, thus inaugurating the long series of arctic expeditions. Then Hudson, still sailing under the Dutch flag, made heroic efforts to find the fabled northwest passage, only to meet his doom in the region of the Bay that has since borne his name.

THE QUEST OF THE POLE

This was in the year 1610. For long generations thereafter successors of Hudson were to keep up the futile quest; and when finally it had been clearly established that no northwest passage to the Pacific could be made available, owing to the climate, the zest for arctic exploration did not abate, but its goal was changed from the hypothetical northwest passage to the geographical pole.

48

Henry Hudson had in his day established a farthest North record of about the eighty-second parallel of latitude—leaving only about five hundred miles to be traversed. But three centuries were required in which to compass this relatively small gap. Expedition after expedition penetrated as far as human endurance under given conditions could carry it. Some of the explorers returned with vivid tales of the rigors of the arctic climate; others fell victim to conditions that they could not overcome. But the seventeenth, eighteenth, and nineteenth centuries passed and left the "Boreal Center" undiscovered.

Toward the close of the nineteenth century the efforts of explorers seemed to be redoubled and one famous expedition after another established new records of "farthest North." The names of Nansen, the Duke of the Abruzzi, and Peary, became familiar to a generation whose imagination seemed curiously in sympathy with that lure of the North which determined the life activities of so many would-be discoverers. So when in the early Autumn of 1909 it was suddenly announced that two explorers in succession had at last, in the picturesque phrasing of one of them, "penetrated the Boreal Center and plucked the polar prize," the popular mind was stirred as it has seldom been by any other event not having either a directly personal or an international political significance.

49

The two men whose claims to have discovered the pole were thus announced in such spectacular fashion, were Dr. Frederick A. Cook, of Brooklyn, and Lieutenant Commander Robert E. Peary, of the United States Navy. Dr. Cook claimed to have reached the pole, accompanied only by two Eskimo companions, on the twenty-first day of April, 1908. Commander Peary reported that he had reached the pole, accompanied by Mr. Matthew H. Henson and four Eskimos, on the seventh day of April, 1909.

The controversy that ensued regarding the authenticity of these alleged discoveries is not likely to be forgotten by any reader of our generation. Its merits and demerits have no particular concern for the purely scientific inquirer. At best, as Professor Pickering of Harvard is reported to have said, "the quest of the pole is a good sporting event" rather than an enterprise of great scientific significance. It suffices for our present purpose, therefore, to know that Dr. Cook's records, as adjudged by the tribunal of the University of Copenhagen, to which they were sent, were pronounced inadequate to demonstrate the validity of his claim; whereas Peary and Henson were adjudged by the American Geographical Society, after inspection of the records, to have accomplished what was claimed for them. What has greater interest from the present standpoint is the question, which the controversy brought actively to the minds of the unscientific public, as to how tests are made which determine, in the mind of the explorer himself, the fact of his arrival at the pole.

50

The question has, indeed, been largely answered in the earlier pages of this chapter, in our discussion of the sextant and the *Nautical Almanac*; for these constitute the essential equipment of the arctic explorer no less than of the navigators of the seas of more accessible latitudes. There is one important matter of detail, however, that remains to be noted. This relates to the manner of using the sextant. On the ocean, as we have seen, the navigator levels the instrument at the visible horizon; but it is obvious that on land or on the irregular ice fields of the arctic seas no visible horizon can be depended upon as a basis for measuring the altitude of sun or stars. So an artificial horizon must be supplied.

The problem is solved by the use of a reflecting surface, which may consist of an ordinary mirror or a dish of mercury. The glass reflector must be adjusted in the horizontal plane with the aid of spirit levels; mercury, on the other hand, being liquid, presents a horizontal surface under the action of gravitation. Unfortunately mercury freezes at about 39 degrees below zero; it is therefore often necessary for the arctic explorer to melt it with a spirit lamp before he can make use of it. These, however, are details aside from which the principles of use of glass and mercury horizon are identical. The method consists simply in viewing the reflected image of the celestial body—which in practice in the arctic regions is usually the sun—and so adjusting the sextant that the direct image coincides with the reflected one. The angle thus measured will represent twice the angular elevation of the body in question above the horizon,—this being, as we have seen, the information which the user of the sextant desires.

51

Of course the explorer makes his "dash for the pole" in a season when the sun is perpetually above the horizon. As he approaches the pole the course of the sun becomes apparently more and more nearly circular, departing less and less from the same altitude. Hence it becomes increasingly difficult to determine by observation the exact time when the sun is at its highest point. But it becomes less and less important to do so as the actual proximity of the pole is approached; and as viewed from the pole itself the sun, circling a practically uniform course, varies its height in the course of twenty-four hours only by the trifling amount which represents its climb toward the summer solstice. Such being the case, an altitude observation of the sun may be made by an observer at the pole at any hour of the day with equal facility, and it is only necessary for him to know from his chronometer the day of the month in order that he may determine from the *Nautical Almanac* whether the observation really places him at ninety degrees of latitude. Nor indeed is it necessary that he should know the exact day provided he can make a series of observations at intervals of an hour or two. For if these successive observations reveal the sun at the same altitude, it requires no *Almanac* and absolutely no calculation of any kind to tell him that his location is that of the pole.

The observation might indeed be made with a fair degree of accuracy without the use of the sextant or of any astronomical equivalent more elaborate than, let us say, an ordinary lead pencil. It is only necessary to push the point of the pencil into a level surface of ice or snow and leave it standing there in a vertical position. If, then, the shadow cast by the pencil is noted from time to time, it will be observed that its length is always the same; that, in other words, the end of the shadow as it moves slowly about with the sun describes a circle in the course of twenty-four hours. If the atmospheric conditions had remained uniform, so that there was no variation in the amount of refraction to which the sun's rays were subjected, the circle thus described would be almost perfect, and would in itself afford a demonstration that would appeal to the least scientific of observers.

52

An even more simple demonstration might be made by having an Eskimo stand in a particular spot and marking the length of his shadow as cast on a level stretch of ice or snow. Just twelve hours later let the Eskimo stand at the point where a mark had been made to indicate the end of the shadow, and it would be found that his present shadow—cast now, of course, in the opposite direction—would reach exactly to the point where he had previously stood. The only difficulty about this simple experiment would result from the fact that the sun is never very high as viewed from the pole and therefore the shadow would necessarily be long. It might therefore be difficult to find a level area of sufficient extent on the rough polar sea. In that case another measurement similar in principle could be made by placing a pole upright in the snow or ice and marking on the pole the point indicated by the shadow of an Eskimo standing at any convenient distance away. At any interval thereafter, say six or twelve hours, repeat the experiment, letting the man stand at the same distance from the pole as before, and his shadow will be seen to reach to the same mark.

53

Various other simple experiments of similar character may be devised, any of which would appeal to the most untutored intelligence as exhibiting phenomena of an unusual character. Absolutely simple as these experiments are, they are also, within the limits of their accuracy,

absolutely demonstrative. There are only two places on the globe where the shadow of the upright pencil would describe a circle, or where the man's shadow would be of the same length at intervals of twelve hours, or would reach to the same height on a pole in successive hours. These two regions are of course the poles of the earth. It may reasonably be expected that explorers who reach the poles will make some such experiments as these for the satisfaction of their untrained associates, to whom the records of the sextant would be enigmatical. But for that matter even an Eskimo could make for himself a measurement by using only a bit of a stick held at arm's length—as an artist measures the length of an object with his pencil—that would enable him to make reasonably sure that the sun was at the same elevation throughout the day—subject, however, to the qualification that the polar ice was sufficiently level to provide a reasonably uniform horizon.

While, therefore, it appears that the one place of all others at which it would be exceedingly easy to determine one's position from the observation of the sun is the region of the pole, it must be borne in mind that the low elevation of the sun, and the extreme cold may make accurate instrumental observations difficult; and it is conceivable that the explorer who had the misfortune to encounter cloudy weather, and who therefore gained only a brief view of the sun, might be left in doubt as to whether he had really reached the goal of his ambition. Fortunately, however, the explorers who thus far claim to have reached the pole record uninterruptedly fair weather, enabling observations to be taken hour after hour. Under these circumstances, there could be no possibility of mistake as to the general location, although perhaps no observation, under the existing conditions, could make sure of locating the precise position of the pole within a few miles.

A curious anomaly incident to the unique geographical location of the pole is that to the observer stationed there all directions are directly south. Yet of course all directions are not one, and the query may arise as to how an explorer who has reached the pole may know in what direction to start on his return voyage. The answer is supplied by the compass, which—perforce pointing straight south—indicates the position of the magnetic pole and so makes clear in which direction lies the coast of Labrador. Moreover if the explorer is provided with reliable chronometers, which of course record the time at a given meridian—say that of Greenwich—these will enable him to determine by the simplest calculation what particular region lies directly beneath the sun at any given time. If, for example, his chronometer shows five o'clock Greenwich time, he knows that the sun's position, as observed at the moment, marks the meridian five hours (*i.e.*, 75° of longitude) west of Greenwich.

While the arctic region appears thus to have given up its last secret, this is not as yet true of the antarctic. The expedition of Lieutenant (now Sir Ernest) Shackleton, in 1908, approached within about one hundred and eleven miles of the South Pole. The intervening space—less than two degrees in extent—represents, therefore, the only stretch of latitude on the earth's surface that has not been trodden by man's foot or crossed by his ships. More than one expedition is being planned to explore this last remaining stronghold, and in all probability not many years—perhaps not many months—will elapse before the little stretch of ice that separated Lieutenant Shackleton from the South Pole will be crossed, and man's conquest of the zones will be complete.

THE HIGHWAY OF THE WATERS

THERE is no doubt that the use of sails for propelling boats is as old as civilization itself. We know that the Egyptians used sails at least 4,000 years before the Christian era. They did not depend entirely upon the sails, however, but used oars in combination with them. Steering was done with single or double oars lashed to the stern and controlled by ropes or levers. This method of steering remained in use until late in the Middle Ages, the invention of the rudder being one of the few nautical inventions made during the centuries immediately following that unproductive period of history known as the Dark Age.

Following the Egyptians, the Phœnicians were the greatest maritime nation of ancient times, but unfortunately they have left no very satisfactory and authentic records describing their boats. In all probability, however, their ships were galleys having one or two banks of oars, fitted with sails similar to those of the Egyptians.

If our knowledge of Phœnician boats is meager, our knowledge of Greek boats, particularly the fighting craft, is correspondingly full. From the nature of its geographical location Greece was necessarily a maritime nation, and it was here that boat-building reached a very high state of development during the period of Greek predominance. Large ships fitted with sails and having several banks of rowers were used habitually in commerce and war, and it was here also that the management of sails became so well understood that oars were often dispensed with except as auxiliaries.

It was in Greece that the custom of having several banks of oars superimposed reached its highest development, but the fabulous number of such banks credited by some authors seems to be entirely without foundation. It is possible that as many as seven banks were used, although the evidence in favor of more than five is very slight.

The writings of Callixenos describe a ship said to have been used by Ptolemy Philopater, which was a forty-banker. This ship is described as 450 feet long, 57 feet broad, carrying a crew of about 7,000 men, of whom 4,000 were rowers. This description need not be taken seriously, as there is no proof that boats of such proportions were ever attempted in ancient times. But it is certain that the Greeks did build large vessels, some of them at least one hundred and fifty feet long—perhaps even larger than this. The tendency of shipbuilders during the later Greek period was to build large, unwieldy boats, which used sails under favorable circumstances, but depended entirely upon oars for manœuvering in battle.

The Romans used similar vessels of large size until the time of the battle of Actium, where the clumsy, many-banked ships of Antony and Cleopatra were destroyed by the lighter single- or double-banked vessels of Augustus. Augustus had adopted the low, swift, handy vessels of a piratical people, the Liburni, who had learned in their sea fights against all kinds of vessels that the lighter type of boat could be used most effectively. Structurally the hulls of these boats were not unlike modern wooden vessels.

While the various types of vessels were being developed in the Mediterranean region, a race of mariners far to the north were perfecting boats in which they were destined to overrun the Western seas from the tropics to the arctic circle. These people, the Norsemen, left few written descriptions that give a good idea of the construction of their boats, which were sufficiently seaworthy to enable the Danes to cross the Atlantic and colonize America. But thanks to one of their peculiar burial customs some of their smaller boats have been preserved and brought to light in recent years. It was their custom when a great chief died, to bury him in a ship, heaping earth over it to form a great mound. In most instances the wood of such boats, buried for a thousand years, has entirely disappeared; but in some mounds the boats have been preserved almost intact.

From the specimens so preserved it is known that the Norsemen knew how to shape the hulls of their boats almost as well as the modern boat-builder. This fact is interesting because the immediate successors of the Norsemen, either through ignorance or choice, reverted to most primitive types in building their boats. Thus it required centuries for them to develop a knowledge of hull-construction that was familiar in ancient times to the northern rovers. Scandinavia itself never entirely forgot the art, and there are boats built in Norway to-day closely similar in all essentials to some of the boats constructed by the Norsemen.

MEDIÆVAL SHIPS

The contrast in shape and construction between the trim ships of the Norsemen and the short, top-heavy vessels which were the approved European type during the early Middle Ages, is most striking. The Mediæval shipbuilders in striving to improve their craft, making them as seaworthy and as spacious as possible, first added decks, and then built towering superstructures at bow and stern. The result was a vessel which would have been so top-heavy that it would be likely to capsize had it not been so broad that "turning turtle" was out of the question.

It was in such ships that Columbus made his voyage of discovery in 1492, although the superstructures fore and aft on his boat were less exaggerated than in some later vessels.

Nevertheless they were veritable "tubs"; and we know from the experience of the crew that sailed the replica of the *Santa Maria* across the ocean in 1893, that they were anything but comfortable craft for ocean traveling.

This replica of the *Santa Maria* was reproduced with great fidelity by the Spanish shipbuilders, and, manned by a Spanish crew, crossed the ocean on a course exactly following that taken by Columbus on his first voyage. Sir George Holmes' terse description of this voyage is sufficiently illuminating without elaboration. "The time occupied was thirty-six days," he says; "and the maximum speed attained was about 6-1/2 knots. The vessel pitched horribly!"

Two full centuries before the discovery of America the rudder had been invented. There is no record to show who was responsible for this innovation, although its superiority over the older steering appliances must have been appreciated fully. But after the beginning of the fourteenth century the rudder seems to have come into general use, entirely supplanting the older side-rudder, or clavus.

MODERN SAILING SHIPS

For a full century after the voyage of Columbus little progress was made in ship construction; short, stocky boats, with many decks high above the water-line at bow and stem continuing to be the most popular type. In the opening years of the seventeenth century, however, the English naval architect, Phineas Pett, departed from many of the accepted standards of his time, and produced ships not unlike modern full-rigged sailing vessels, except that the stern was still considerably elevated, and the bow of peculiar construction. One of Pett's ships, *The Sovereign of the Seas*, was a vessel 167 feet long, with 48 foot beam, and of 1,683 tons burthen. The introduction of this type of vessel was a distinct step forward toward modern shipbuilding.

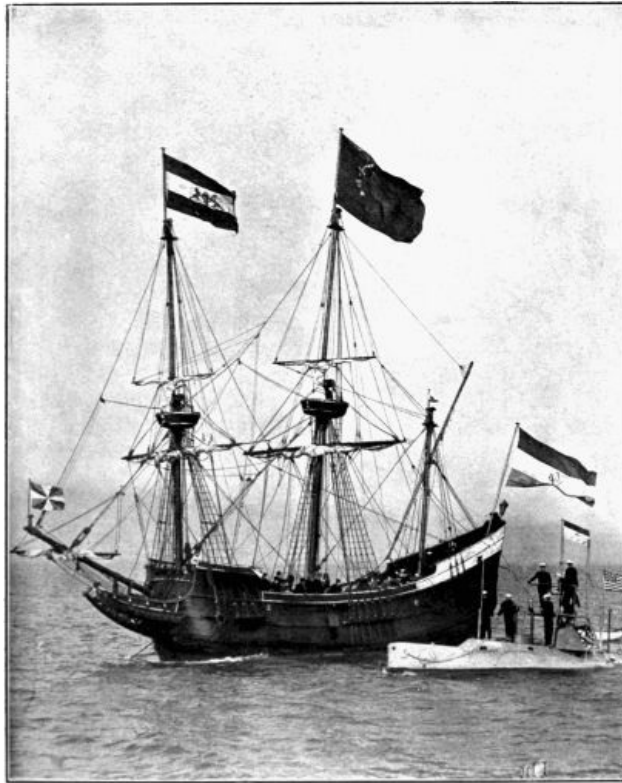

THE OLD AND THE NEW—A CONTRAST

The replica of Henry Hudson's famous *Half Moon*, a typical fighting ship of the 16th century, and a modern submarine. The photograph was taken in New York Harbor during the Hudson-Fulton celebration, September, 1909.

The tendency of shipbuilders during the eighteenth century was to increase the length of vessels in proportion to the breadth of beam and diminish the depth of the hull and superstructures, above the water line, with improved sailing qualities. England's extensive trade with India and the far East was conducive to this development, as the "East Indiamen" were necessarily a combination of merchant vessel and battleship.

In the first half of the nineteenth century America rose to great commercial importance thanks to her fleets of fine sailing vessels. Speed rather than strength in their ships was the aim of American ship-builders, to gain which they built boats proportionately longer and narrower than ever constructed before for ocean traffic. The culminating type of wooden sailing ship was represented by the "Baltimore clippers," in which the length was five, and even six, times the beam, with light rigging and improved mechanical devices for handling it, whereby the amount of manual labor was greatly lessened. One of these ships, the *Great Republic*, built in 1853, was

over three hundred feet long, and 3,400 tons register. She was a four-masted vessel, fitted with double topsails, with a spread of canvas about 4,500 square yards.

The modern descendant of the wooden clipper ship is the schooner with from four to six masts. Some of these vessels exceed the older boats in size and carrying capacity, if not in speed. Perhaps the largest schooner ever constructed is the *Wyoming*, which was completed at Bath, Maine, early in the year 1910. This vessel is 329 feet long and 50 feet broad. It has a carrying capacity of 6,000 tons. The construction of such a vessel at so recent a period suggests that the day of the sailing ship is by no means over notwithstanding that a full century has elapsed since the coming of the steamboat. Here, as so often elsewhere in the history of progress, it has happened that the full development of a type has not been reached until the ultimate doom of that type, except for special purposes, had been irrevocably sealed. Ever since the full development of the steamboat in the early decades of the nineteenth century, the sailing ship has seemed almost an anachronism; and yet, in point of fact, the steamship did not at once outrival its more primitive forerunner. Even in the matter of speed, the sailing ship more than held its own for a generation or so after the steamship had been placed in commission. In 1851 the American clipper *Flying Cloud* made 427 knots in twenty-four hours; and *The Sovereign of the Seas* bettered this by averaging over eighteen miles an hour for twenty-four consecutive hours. The Atlantic record for sailing vessels is usually said to have been made in 1862 by the clipper ship *Dreadnought* in a passage between Queenstown and New York, the time of which is stated as nine days and seventeen hours. It should be remarked, however, that the authenticity of this extraordinary performance has been challenged.

62

Be that as it may, it is certain that the speediest sailing ships, granted favorable conditions of wind and wave, more than surpassed the best efforts of the steamship until about the closing decades of the nineteenth century. But of course long before this the steamship had proved its supremacy under all ordinary conditions. Even though sailing ships continued to be constructed in large numbers, their picturesque rigging became less and less a feature in all navigable waters, and the belching funnel of the steamship had become a characteristic substitute as typifying the sea-going vessel.

63

The story of the development of this new queen of the waters must now demand our attention. It begins with the futile efforts of several more or less visionary enthusiasts who were contemporaries of James Watt, and who thought they saw great possibilities in the steam engine as a motive power to take the place of oars and sails for the propulsion of ships.

EARLY ATTEMPTS TO INVENT A STEAMBOAT

Among the first of these was an American named John Fitch. Judged by the practical results of his efforts, he was not a highly successful inventor; as a prophet, however, and as an experimenter whose efforts fell just short of attainment, he deserves a conspicuous place in the history of an epoch-making discovery. Yet his prophecy was based on his failures. From 1780, for twenty years he strove to perfect a steamboat. His efforts did not carry him far beyond the experimental stage. But his courage and enthusiasm never waned. "Whether I bring the steamboat to perfection or not," he declared, "it will some time in the future be the mode of crossing the Atlantic for packets and armed vessels."

At that very time Benjamin Franklin said this would never be. But twenty years later Fulton's *Clermont* paddled up the Hudson River from New York to Albany and opened the era that saw Fitch's prophecy fulfilled. This was in 1807—a year that must stand as the most momentous in maritime history. In that year the little *Clermont* steamed slowly from New York to Albany, a distance of one hundred and fifty miles in thirty-two hours, unaided by sails or oars, and propelled entirely by steam-power. A sail-boat could cover the distance in the same number of hours; a modern torpedo boat in one-sixth the time. Yet no performance of any boat, before or since, had such far-reaching effects upon the progress of the world.

64

When Fulton turned his attention from his favorite theme—the invention of a submarine boat—and took up the question of perfecting a boat propelled by steam, he did not find himself the first or the only inventor in the field. For a hundred years, in round numbers, men had been wrestling with the question of applying steam pressure to boat propulsion. All manner of more or less ingenious devices had been conceived, most of them having a germ of success in the principles involved, but all of them being failures in actual practice.

Among the most promising of these first steamboats were those in which the propeller, or the paddle-wheel, was tried; but neither of these methods was looked upon favorably at first. Less promising was one in which the motive power was a jet of water pumped through a submerged tube—a principle that still periodically fascinates certain modern inventors.

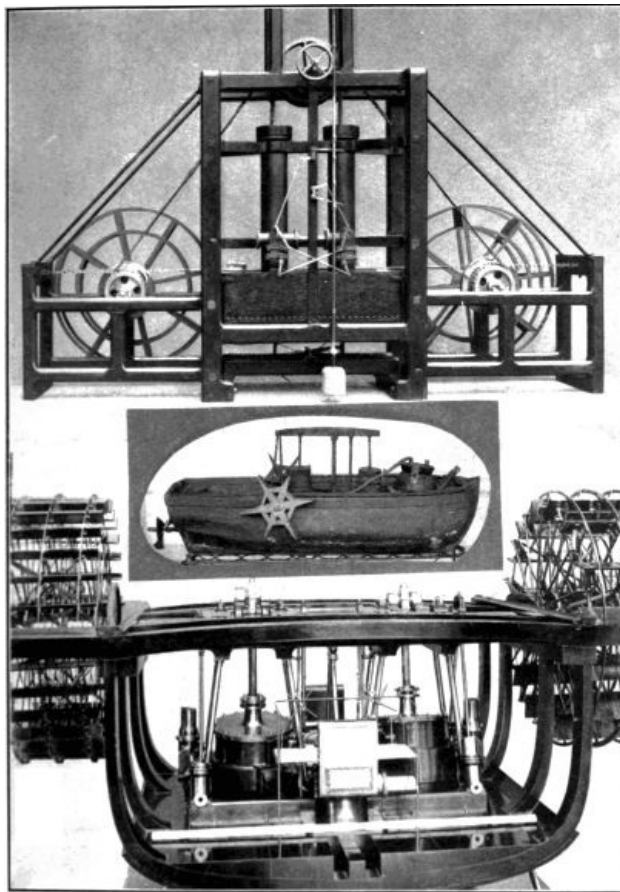

MARINE ENGINES AND AN EARLY TYPE OF STEAMBOAT.

The small figure in the centre represents a very remarkable steamboat constructed in America by John Fitch. The precise date of its construction is not clearly established, but the inventor had made efforts at steam navigation as early as 1776. The upper figure shows a marine engine made in Scotland in 1788 for Patrick Miller by William Symington. It was used to equip a double-hulled pleasure boat which it is said to have propelled at the rate of five miles an hour. The motive power is supplied by two open-top Newcomen cylinders. The lower figure represents a modern side wheel steamer with oscillating engines.

But the boats that seemed to have come nearer attaining practical success for the moment were those in which several sets of oars worked by steam were placed vertically on each side of the hull, the machinery so arranged that the oars were dipped into the water and drawn sternward by one motion of the machinery, raised and carried toward the bow by the opposite motion. In some of these boats it was planned to have four sets of oars, two sets on each side, which were to work alternately, so that while one set was traveling forward through the air, its mate would be paddling through the water, thus insuring a continuous forward impulse. But the machinery for these boats proved to be too cumbersome and complicated for practical results, and this idea was finally abandoned. The jet of water did not prove any more successful, and but two other methods were available—the propeller and the paddle-wheel.

Both of these methods of utilizing the power of moving water had been familiar in the form of the Archimedian screw and the commonplace overshot or undershot mill-wheel. In these examples, of course, the force of the water was used to move machinery, reversing the action of the paddle-wheel of the boat. And yet the principles were identical. Obviously if the conditions were reversed, and the undershot mill-wheel, for example, forced against the water with corresponding power, the propulsive effect might be great enough—since action and reaction are equal—to move a boat of considerable size. But curiously enough, at the time when Fulton began his experiments there was a wave of general belief that when this principle was applied to boats it would fail. The reason for this lay in the fact that several such boats had been built from time to time, and all had failed. The fault, of course, lay in some other place than in their paddle wheels; but for the time being the wheel, and not the machinery, was shouldered with the blame.

Just a hundred years before Fulton finally produced his practical paddle-wheel steamboat, a prototype was built by the Spaniard, Blasco de Gary. In 1707, this inventor constructed a model paddle-wheel steamboat, and tried it upon the river Fulda. But this model boat failed to work, and the experiment was soon forgotten.

Twenty-five years later Jonathan Hulls of England patented a marine engine which he proposed to use in a boat which was to be propelled by a stern wheel. His idea was to use his boats as tug- or tow-boats, and to equip the larger vessels themselves with steam. But his engines were defective and his boats did not achieve commercial success.

During the time of the American Revolution, a French inventor, the Marquis de Jouffroy, made

several interesting experiments with steam-propelled boats, using the principle of the paddle which was dipped and raised alternately as referred to a few pages back. His boats made several public trials, one of them ascending the Seine against the current; but nevertheless, the French government refused to grant the inventor a patent. Presumably, therefore, the boat was not considered a practical success in official circles; and this view is tacitly conceded by the fact that no more boats of its type were constructed. Had they been really practical steamboats it is a fair presumption that others would have been constructed and put into operation, regardless of patents. Nevertheless, in France to-day, the Marquis de Jouffroy is often referred to as the father of steam navigation.

The idea of propelling a boat by means of a jet of water pumped out at the stern by steam pumps was given a practical test in 1784, by James Rumsey. His boat made a trial trip on the Potomac River in September of that year, General Washington and other army officers being present on this occasion. The boat was able to make fairly good progress through the water, and seemed so promising that a company was formed by capitalists known as the Rumsey Society, for promoting the idea and building more boats. Rumsey was sent to England where he undertook the construction of another boat, meanwhile taking out patents in Great Britain, France, and Holland. Before his boat was completed, however, he died suddenly, and the Rumsey Society passed out of existence shortly afterwards.

An even closer approach to practical success was made in Scotland by James Symington, who in 1788, in association with two other Scotchmen, Miller and Taylor, constructed a boat consisting of two hulls, with a paddle-wheel between them worked by a steam-engine. This boat worked so well that in 1801, Lord Dundas engaged Symington to build a smaller boat to be used for towing on the Caledonian Canal. This boat, called the *Charlotte Dundas*, completed in 1802, is said to have been capable of towing a vessel of one hundred and forty tons "nearly four miles an hour." But in doing this the resulting "wash" so threatened the banks of the canal that the vessel was laid up and finally rotted and fell to pieces.

By many impartial judges this boat is considered the first practical steamboat, and its failure to establish its claim due to the force of circumstances rather than to any inherent defects. Symington was too poor to pursue his work independently, and was deterred by the attitude of James Watt, who "predicted the failure of his engine, and threatened him with legal penalties if it succeeded." And when at last he received an order for eight smaller vessels from the Duke of Bridgewater, his patron died before the details of the agreement had been completed. So that while he failed in accomplishing what was done by Fulton a few years later, it is certain that, as Woodcraft says, "He combined for the first time those improvements which constitute the present system of steam navigation."

Some of Symington's engines have been preserved, and one of them is now in the Patent Office Museum in London. Since the beginning of practical steam navigation this engine has been tested several times, the result showing that Woodcraft's estimate is not overdrawn.

While Symington was thus perfecting a paddle-boat, an American, Col. John Stevens of Hoboken, New Jersey, was on the verge of accomplishing the same end with a screw-propeller boat—a form of steamship that did not come into use until some forty years later.

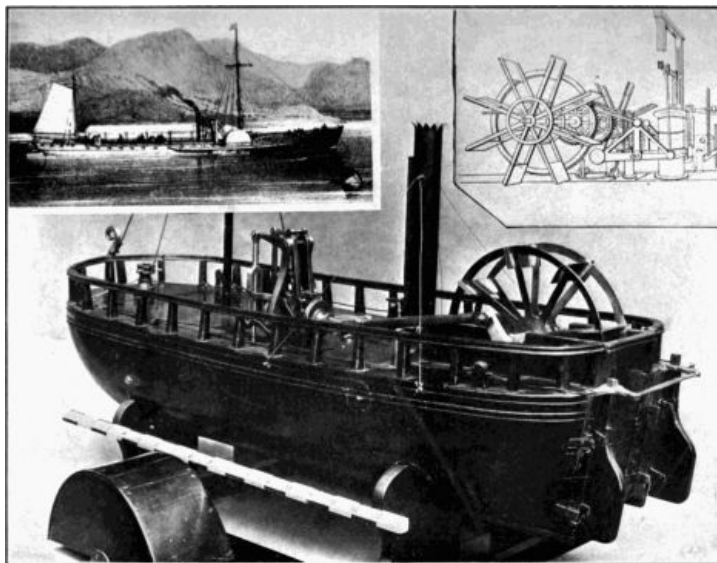

THE STEAMSHIPS "CHARLOTTE DUNDAS" AND "CLERMONT."

The "Charlotte Dundas" (lower figure) was built in 1801 by A. Hart at Grangemouth, Scotland, and engined by William Symington, for service on the Forth and Clyde Canal. Its length was 56 feet; beam 18 feet; depth 8 feet. The boat was a practical success, but its use was discontinued because of the damage done to the banks of the Canal by the wash of the paddles. The upper left-hand figure is a picture of Fulton's "Clermont." The diagram at the right represents the "Clermont's" paddle wheels and the mechanism by which they were worked.

Stevens also invented what he called a "rotary engine" which was really an engine constructed on the same principle as the modern turbine engine. It was a small affair which he placed in a skiff, and used for turning the screw-propeller of a boat which was able to travel at a rate of three or four miles an hour on the North River, during the fall of 1802. But Stevens found so much difficulty in packing the blades of this engine without causing too much friction that he finally abandoned it for the more common type of reciprocating engine. But if this little steamboat had its defects, it nevertheless contained the germs of two great features of steam navigation—the screw propeller and the turbine engine, the advantage of the first of which was not recognized for nearly half a century, and the other not until almost a full century later.

In 1804 Stevens produced another propeller steamboat, this one using the ordinary type of reciprocating engine, and being notable for having twin screws of a pattern practically identical with the screws now in use. This boat was able to steam at a rate of four miles an hour on many occasions, and at times almost double this rate, according to some observers. The engines of this boat are still in existence, and on several occasions since 1804 have been placed in hulls corresponding as nearly as possible to the original, and have demonstrated that they could force the boat through the water at six or eight miles an hour. These engines in a modern hull were exhibited at the Columbian Exposition at Chicago, in 1893. They supply irrefutable evidence that the practical steamboat had been invented at least three years before Fulton's historic voyage in 1807. Yet no one questions that it was Fulton's, not Stevens', invention that inaugurated steam navigation.

Just why this was so is a little difficult to comprehend at this time, unless it was that Stevens' boat was such a small affair that it did not attract the attention it deserved, as did Fulton's larger boat. And yet we should not be guided too much by retrospective judgment. The significant fact remains that Stevens himself did not have entire confidence in his boat, or in the principle of his screw propeller, as is shown by the fact that three years later, while Fulton was building the *Clermont*, Stevens was also constructing a steamboat, not along the lines of his previous inventions, but as a paddle-wheel boat. This leaves little room for doubt that Stevens had not full confidence in the propeller; and when an inventor himself mistrusts his own device, there is little likelihood that anyone else will supply the necessary confidence. This may account for the fact that Stevens found difficulty in securing financial backing for his enterprise; and when such backing was found it was for the construction of the paddle-wheel boat, which was finished a few months after Fulton's boat had solved the problem of steam navigation.

FULTON AND THE CLERMONT

As we shall see in another place, Fulton was no novice in the construction of peculiar boats at this time. He had built experimental boats both at home and abroad, was familiar with the principle of the screw and the paddle-wheel, and had come to have absolute confidence in the possibility of propelling boats at a good rate of speed by the use of steam. When he began his now famous *Clermont*, in the spring of 1807, it was not as an experimental skiff, but as a boat of one hundred and fifty tons burden—half again the size of the boats in which Columbus had discovered America—to be placed in commission between Albany and New York city. By August, this boat was completed, and the engines in place, and, under her own steam, the new boat was moved from the Jersey shipyard where she was constructed, and tied up at a New York dock. On August 7th, she started on her maiden trip up the Hudson. To the astonishment of practically every one of the persons in the great throng that had gathered along the shores, she left her dock in due course, and with wind and tide against her, steamed up the river at the rate of about five miles an hour. At this speed she covered the entire distance between New York and Albany, settling forever the question of the practicability of steam navigation.

The impression this fire-belching monster made upon the sleepy inhabitants as it passed along the river can be readily imagined. An eye-witness account of this first passage of the *Clermont* has been given by an inhabitant at the half-way point near Poughkeepsie.

"It was the early autumn in 1807," he wrote, "that a knot of villagers was gathered on the high bluff just opposite Poughkeepsie, on the west bank of the Hudson, attracted by the appearance of a strange, dark-looking craft which was slowly making its way up the river. Some imagined it to be a sea-monster, while others did not hesitate to express their belief that it was a sign of the approaching Judgment. What seemed strange in the vessel was the substitution of lofty and straight black smoke-pipes, rising from the deck, instead of the gracefully tapered masts that commonly stood on the vessels navigating the stream; and, in place of spars and rigging, the curious play of the working-beam and pistons, and the slow turning and splashing of the huge, naked paddle-wheels, met the astonished gaze. The dense clouds of smoke as they rose wave upon wave, added still more to the wonderment of the rustics.

"This strange looking craft was the *Clermont*, on her trial trip to Albany. On her return-trip, the curiosity she excited was scarcely less intense—the whole country talked of nothing but the sea-monster, belching fire and smoke. The fishermen became terrified and rowed homewards, and they saw nothing but destruction devastating their fishing grounds; whilst the wreaths of black vapor, and rushing noise of the paddle-wheels, foaming with the stirred-up water, produced great excitement among the boatmen."

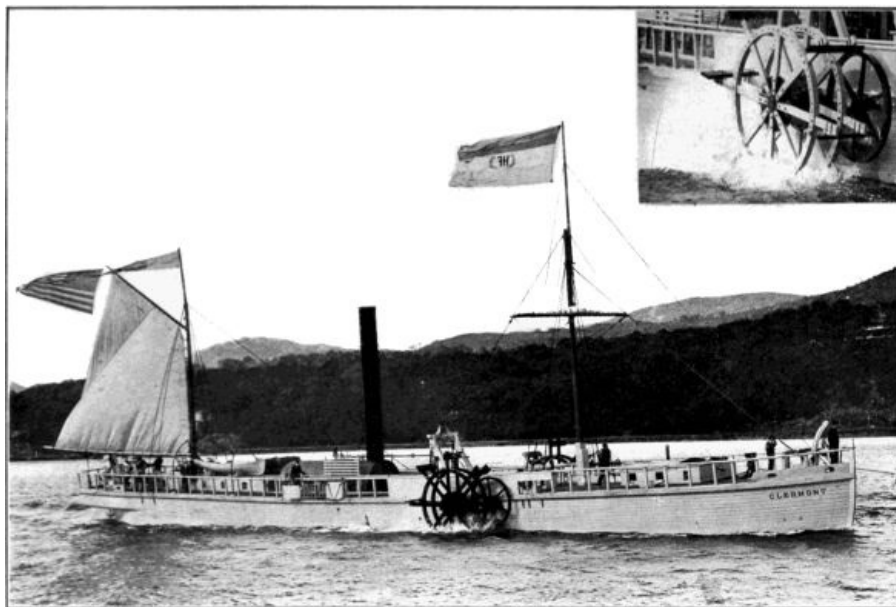

THE CLERMONT

The replica of Robert Fulton's first steamboat which took part in the Hudson-Fulton celebration in September, 1909. The small picture shows one of the paddle-wheels in detail. The original *Clermont*, the first commercially successful steamboat, was put in commission for the New York-Albany service in 1807.

While acknowledging fully Fulton's right to the claim of being "the father of steam navigation," as he has been called, there is no evidence to show that he introduced any new principle or discovery in his application of steam to the *Clermont*. The boiler, engine, paddle-wheel—every part of the boat had been known for years. Yet this does not detract from the glory of Fulton, who first combined this scattered knowledge in a practical way, and demonstrated the practicality beyond question.

73

SEA-GOING STEAMSHIPS

The first war steamer and ocean steamer ever attempted was built by Fulton, in 1813. It was called the *Demolgos*, and was not a practical success, and made no attempts to take protracted ocean voyages. The first steamship to cross was the *Savannah* in 1819. She made the voyage from Savannah to Liverpool in twenty-five days, using her paddle-wheels part of the time, but at other times depending entirely upon her sails. She was a boat of three hundred and fifty tons, and her paddle-wheels were arranged so that they could be hauled in upon the deck and stowed away in bad weather.

Following the *Savannah* several similar combination sailing and steam-propelled boats were constructed, the navigators coming to have more and more faith in the possibilities of steam, so that less sail was carried. These vessels continued to reduce the time of the passage between Europe and America, until the voyage had been made in about seventeen days. Then, in 1838, two vessels, the *Sirius* and the *Great Western*, for the first time using steam alone as motive power, made record voyages, the *Great Western* crossing in twelve days, seven and a half hours. This was considered remarkable time—an average speed of over two hundred miles a day. Something like four hundred and fifty tons of coal were consumed on the voyage, which impressed many as a great extravagance of fuel. Some of the ocean liners at present consume more than twice this amount in a single day.

74

On July 4, 1840, the *Britannia*, the first steamer of the Cunard Line, started on its maiden voyage from Liverpool to Boston. The voyage was made in fourteen days, among the passengers being Samuel Cunard, a Quaker of Halifax, who was the founder of the enterprise. The population of Boston went mad on the arrival of this boat; streets and buildings were decorated, and the day was given over to the regular holiday amusements. Cunard received upward of eighteen hundred invitations to dinner that evening.

The year 1840, then, may be considered as one of the vital years in the progress of steam navigation. Since that time no year has passed without seeing some important addition and improvement made in the conquest of the ocean, either in size, shape, or speed of the "greyhounds."

SHIPS BUILT OF IRON AND STEEL

Even before the introduction of steam as a motive power for boats shipbuilders had been

casting about for some satisfactory substitute for wood in the construction of vessels. One reason for this was that suitable wood was becoming scarce and very expensive. But also there was a limit to the size that a wooden vessel might be built with safety. A wooden boat more than three hundred feet long cannot be constructed without having dangerous structural weakness.

Naturally the idea that the only suitable material for boat-building was something lighter than water,—something that would float—which had been handed down traditionally for thousands of years, could not be overcome in a moment. And surely such a heavy substance as iron would not be likely to suggest itself to the average ship-builder. But at the beginning of the nineteenth century rapid strides were being made in theoretical, as well as applied science, and the idea of using metal in place of wood for shipbuilding began to take practical form.

Richard Trevithick, whose remarkable experiments in locomotive building have been noted in another chapter, had planned an iron ship as early as 1809. He did not actually construct a vessel, but he made detailed plans of one—not merely a boat with an iron hull, but with decks, beams, masts, yards, and spars made of the same material. It was nearly ten years after Trevithick drew his plans, however, before the first iron ship was constructed. Then Thomas Wilson of Glasgow built a vessel on practically the same lines suggested by Trevithick.

This vessel, finished in 1818, and called the *Vulcan*, was the pioneer of all iron boats. For at least sixty years it remained in active service. Indeed, for aught that is known to the contrary, this first iron boat may be still in use in some capacity.

One of the most surprising and interesting things to shipbuilders about the *Vulcan*, and the boats that were constructed after her, was the fact that they were actually lighter in proportion to their carrying capacity than ships of corresponding size built of wood. In wooden cargo ships the weight of the hull and fittings varies from 35 to 45 per cent. of the total displacement, while iron vessels vary from 25 to 30 per cent. This was a vital point in favor of the iron vessel, and one that appealed directly to practical builders. But the public at large looked askance at the new vessels. To "sink like a stone" was proverbial; and everyone knows that iron sinks quite as readily as stone.

But very soon a convincing demonstration of the strength of iron vessels brought them into favor. A great storm, sweeping along the coast of Great Britain in 1835, drove many vessels on shore, among them an iron steamboat just making her maiden voyage. The wooden vessels without exception were wrecked, most of them destroyed, but the iron vessel, although subjected to the same conditions, escaped without injury, thanks to the material and method of her construction.

From that time the position of the iron steamship was assured. And whereas sea voyagers had formerly looked askance at iron passenger boats they now began to distrust those built of wood. By the middle of the century, iron shipbuilding was at its height, and in the decade immediately following, the *Great Eastern* was finished—possibly the largest and most remarkable structure ever built of iron, on land or sea. In recent years larger ships have been constructed, but these ships are made of steel.

The *Great Eastern* marked an epoch in shipbuilding. In size she was a generation ahead of her time, but the innovations in the method of her construction gave the cue to modern revolutionary shipbuilding methods. Sir George C. V. Holmes gives the following account of the great ship:

"She was originally intended by the famous engineer, Mr. I. K. Brunel, to trade between England and the East. She was designed to make the voyage to Australia without calling anywhere *en route* to coal, a feat which, in the then state of steam-engine economy, no other vessel could accomplish. It was supposed that this advantage, coupled with the high speed expected from her great length, would secure for her the command of the enormous cargoes which would be necessary to fill her. Mr. Brunel communicated his idea that such a vessel should be constructed for the trade to the East to the famous engineer and shipbuilder, the late Mr. John Scott Russell, F.R.S., and he further persuaded his clients, the directors of the Eastern Steam Navigation Company, of the soundness of his views, for they resolved that the projected vessel should be built for their company, and entrusted the contract for its execution to the firm of John Scott Russell & Co., of Millwall.

"Mr. Scott Russell and Mr. Brunel were, between them, entitled to the credit of the design, which, on account of the exceptional size of the ship, presented special difficulties, and involved a total departure from ordinary practice.

"Mr. Scott Russell had systematically, in his own previous practice, constructed iron ships with cellular bottoms, but the cells had only five sides, the uppermost side on the inside being uncovered. Over a large portion, however, of the bottom of the *Great Eastern* the cells were completed by the addition of an inner bottom, which added greatly both to the strength and to the safety of the ship. It was also Mr. Brunel's idea that the great ship should be propelled by both paddles and screw. Mr. Scott Russell was responsible for the lines and dimensions, and also for the longitudinal system of framing, with its numerous complete and partial transverse and longitudinal bulkheads.

"The following are some of the principal dimensions and other *data* of the *Great Eastern*:

Length between perpendiculars	680 feet
Length on upper deck	692 "
Extreme breadth of hull	83 "
Width over paddle-box	120 "

Depth from upper deck to keel	58	"
Draught of water (laden)	30	"
Weight of iron used in construction	10,000	tons
Number of plates used in construction	30,000	
Number of rivets used in construction	3,000,000	
Tonnage, gross	18,914	tons
Nominal power of paddle engine	1,000	H. P.
Nominal power of screw engines	1,600	"

"The accommodation for passengers was on an unprecedented scale. There were no less than five saloons on the upper, and as many on the lower deck, the aggregate length of the principal apartments being 400 feet. There was accommodation for 800 first-class, 2,000 second-class, and 1,200 third-class passengers, and the crew numbered 400. The upper deck, which was of a continuous iron-plated and cellular structure, ran flush from stem to stern, and was twenty feet wide on each side of the hatchways; thus two spacious promenades were provided, each over a furlong in length. The capacity for coal and cargo was 18,000 tons.

79

"The attempts to launch this vessel were most disastrous, and cost no less than £120,000, an expense which ruined the company. The original company was wound up, and the great ship sold for £160,000 to a new company, and was completed in the year 1859. The new company very unwisely determined to put her on the American station, for which she was in no way suited. During her preliminary trip the pilot reported that she made a speed of fully 14 knots at two-thirds of full pressure, but the highest rate of speed which she attained on this occasion was 15 knots, and on her first journey across the Atlantic the average speed was nearly 14 knots, the greatest distance run in a day having been 333 nautical miles. The great value of the system adopted in her construction was proved by an accident which occurred during one of her Transatlantic voyages. She ran against a pointed rock, but the voyage was continued without hindrance. It was afterwards found that holes of the combined length of over 100 feet had been torn in her outer bottom; but, thanks to the inner water-tight skin, no water was admitted."

Between the years 1860 and 1870 great improvements were made in marine engines, and screw-steamers very generally replaced side-wheel boats for ocean traffic. The improvements in the engines consisted largely in the use of higher pressures, surface condensation, and compounding of the cylinders, which resulted in a saving of about half the amount of fuel over engines of the older type. As a result steamers were able to compete successfully with the sailing ships, even as freighters for long voyages, such as those between Europe and Australia.

80

During the reactive period in France immediately following the Franco-Prussian war, when there was great activity in shipbuilding, the use of mild steel plates in place of wrought iron was tried. The superiority of this material over iron was quickly demonstrated, and as the cost of steel was constantly lessening, thanks to the newly discovered methods of production, steel practically replaced iron in ship construction after this time.

It was during this same period that a new type of passenger steamer was produced—the "ocean greyhound." The first of these was the *Oceanic*, built by the White Star Company in 1871. This ship was remarkable in many ways. Her length, four hundred and twenty feet, was more than ten times her beam; iron railings were substituted for bulwarks; and the passenger quarters were shifted from the position near the stern to the middle of the vessel. All these changes proved to be distinct improvements, and the *Oceanic* became at once the most popular, as well as the fastest ocean liner.

Like all the other boats of the seventies and early eighties, the *Oceanic* was a single-screw vessel. The advantage of double propellers in case of accident had long been recognized, but hitherto twin-screws had not proved as efficient as a single screw in developing speed. But in 1888 the *City of Paris* (now the *Philadelphia*) a twin-screw boat, began making new speed records, and the following year her sister ship, the *New York*, and the new *Majestic* and *Teutonic*, entering into the ocean-record contests, cut the time of the passage between Europe and America to less than six days.

81

The advantages of the double-screw over the single are so many and so manifest as to leave no question as to their superiority. The disabling of the shaft or screw of the single-screw steamer, or the derangement of her rudder renders the vessel helpless. Not so the twin-screw ship; for on such ships the screws can be used for steering as well as propelling. And it has happened many times that twin-screw ships have crossed the ocean with the steering gear disabled, or with one screw entirely out of commission.

THE TRIUMPH OF THE TURBINE

In recent years the greatest revolutionary step in steamship construction has been the invention and development of the turbine engine, the mechanism of which has been described elsewhere. Since the day of the little *Turbinia*, whose speed astonished the nautical world, the limit for size and speed of ships has again been materially advanced, and no thinking person will venture to predict restricting limits without a modifying question mark.

At the beginning of the twentieth century a keen rivalry had developed between England and the Continent for supremacy in transatlantic traffic, America having dropped out of the race. The

Germans in particular had produced fast boats, such as the *Deutschland* and *Kaiser Wilhelm II*, which for several years held the ocean record for speed. But meanwhile the turbine engine was being perfected in England, the land of its invention, and presently turbine "greyhounds" began crossing the ocean and menacing the records held by the boats equipped with the older type of engine.

The reciprocating marine engine, however, had been steadily improved, until it was a marvel in efficiency. Quadruple expansion engines driving twin-screws of a size and shape known to develop the greatest efficiency, for several years offered invincible competition to the new type of engine. There were new conditions to be met, new difficulties to be overcome.

A decisive test of the merits of the turbine engine was given in 1905, when the Cunard Company built two vessels, the *Caronia* and *Carmania*, of exactly the same size and shape, the *Caronia* having the highest type of quadruple expansion reciprocating engines, while the *Carmania* was equipped with turbine engines. Here was a fair test of efficiency between the two types. And the turbine boat proved herself the better of the two by developing more than a knot greater speed per hour.

Still the *Carmania* offered no serious competition in speed to several of the German flyers. But in 1908 two more turbine ships, the *Lusitania* and *Mauretania* began making regular transatlantic voyages, and quickly distanced all competitors.

In size as well as in speed these sister ships mark an epoch in navigation. Turbine engines take the place of the usual reciprocating type, acting on four propellers for going ahead, and two separate propellers for going astern. These engines develop 68,000 horse-power. Stated in this way these figures convey little idea of the power developed. But when we say that it would take a line of horses one hundred and twenty miles long hitched tandem to develop the power generated in the compact space of the *Mauretania's* engine room, some idea of the power is gained.

It is not the matter of power, size, or speed alone that makes the twentieth century passenger steamer so completely outclass her predecessors. It is really the matter of comfort and safety afforded the ocean travelers. Safety against sinking from injury to the hull was provided for by the introduction of watertight compartments half a century ago, as we have seen; and the size of the *Great Eastern* has been surpassed in only a few instances. But it is since the beginning of the present century that two revolutionary safety devices have been perfected—wireless telegraphy and the submarine signaling apparatus. The wireless apparatus has been described in another chapter, and as it is used almost as much on land as at sea, cannot be considered as solely a nautical appliance. But the submarine signaling device, which is dependent upon water for transmission, is essentially a nautical mechanism.

SUBMARINE SIGNALING

It is difficult for the average landsman to appreciate that the one thing most dreaded by mariners is fog. Dark and boisterous nights which frighten the distressed landsman have no terrors for the sailor. Given an open sea-way he knows that he can ride out any gale that blows. It is the foggy night that fills him with apprehension.

In perfectly still weather the sound of the fog horn carries far enough, and indicates location well enough so that two ships approaching each other, or a ship approaching a bell buoy, can detect its location and avoid danger. But this is under favorable conditions; and unfortunately such conditions do not always prevail. And if there is a wind stirring or the sea running high atmospheric sounds cannot be depended upon. A fog whistle whose sound ought to carry several miles under ordinary conditions, may not be heard more than a ship's length away. And scores of accidents, such as collisions between ships, have happened in fogs, when both vessels were sounding their fog whistles at regular intervals.

When wireless telegraphy was perfected sufficiently to be of practical use, great hopes were entertained that this discovery could be used to give warning and prevent accidents to fog-bound vessels. But experience has shown that its usefulness is confined largely to that of calling for help after the accident, rather than in preventing it. Thus in 1908 when the wireless operator on board the steamer *Republic* flashed his message broadcast telling ships and shore-stations for hundreds of miles around that his vessel had been run down in a fog and was sinking, he could only give the vessels that hurried to the *Republic's* aid an approximate idea of where they could find her. The use of another electric appliance, of even more recent invention than the wireless telegraph, was necessary for locating the exact position of the stricken ship. This was the submarine signaling device, which utilizes water instead of air as a medium for transmitting sound.

Benjamin Franklin pointed out more than a century ago that water carries sound farther and faster than air, and carries it with greater constancy. Density, temperature, and motion of the atmosphere act upon aerial sound waves to reflect and refract them in varying degrees; but these waves are not affected when water is the medium through which they are passing. The knowledge of these facts was turned to little practical account until the closing years of the last century when Arthur J. Mundy of Boston, and a little later Prof. Elisha Gray of Chicago, began experiments together that resulted finally in a practical submarine signaling apparatus which is now installed as a system on boats and buoys in dangerous places along the coasts, particularly near the great highways of ocean travel.

The principle upon which this system is based is simply that of sound waves transmitted through the water and detected at a distance by a submerged electrical transmitter. The sound transmitted is usually that of a submerged bell. It is possible for a person whose head is submerged to hear the ringing of such a bell distinctly for a long distance; but of course for practical purposes such submergence is out of the question. The receiving apparatus of the Mundy-Gray signaling device offers a substitute in the form of a submerged "artificial ear"—an electrical transmitter, connected with a telephone receiver.

In the early experiments a small hollow brass ball filled with water and containing a special form of electrical transmitter was lowered over the side of a ship and connected by insulated wires to the receiver of a telephone in the pilot house. The sound of a submerged bell could be heard in this manner at a distance of ten or twelve miles. The location of the bell could be determined by having two such brass balls, one on each side of the hull of the vessel but not submerged to a depth below that of the hull, so that the ship itself acts as a screen in obstructing the sound waves coming from the bell. By listening alternately to the sounds of the bell transmitted through these two submerged balls it was found that the ball on the side of the ship toward the bell gave a distinctly louder sound. By turning the ship so that the sounds were of equal intensity the direction of the bell could be determined as either directly ahead or astern; and by using the compass the exact location could be determined.

But such brass-ball transmitters can be used only when the vessel is moving at a rate not exceeding three miles an hour. They are, therefore, of little value for ocean liners whose reduced speed far exceeds this. But the inventors discovered presently that by using the inside of the outer steel skin of the ship's hull below the water line as one side of the brass ball, the transmitter would work equally well. Indeed, with added improvements, this hollow metal device fastened to the inside of the hull on each side, with connecting wires leading to the pilot house, in its perfected form will pick up the sound of the submerged bell equally well at any speed, regardless of calm or storm.

The chief defect of this arrangement was that the sound of the pulsations of the engines of the ship were also heard, and interfered seriously with the detection of the sound of the bell. But presently a receiving device was perfected which ignored all sounds but those of the bell, thus giving the mariner a means of protection against accidents that could be depended upon absolutely at all times regardless of speed or weather conditions.

When this stage of perfection of the signaling device was reached the various governments began installing the instruments on buoys, lighthouse sites, and light-ships, using various mechanical devices for ringing the bells, and timing the strokes so that the mariners could tell by the intervals just what bell he was in touch with, as he knows each lighthouse by the intervals between the Hashes of its lights. A further development in the signaling device was to equip ships with submerged bells, as well as with the receiving apparatus. In this way two ships could communicate with each other, or with a shore receiving station, by using the Morse telegraph code, just as in the case of telegraphy.

The maximum distance at which such communications may be detected is about fifteen miles, and the approximate distance from the bell can be gauged from the clearness of the sound heard in the telephone receiver. At the distance of a quarter of a mile the sound of the bell is so loud that it is painful to the listener if the receiver is held against the ear, while at ten or twelve miles the sound is scarcely audible.

Probably the most dramatic rescue at sea in recent years was that of the passengers and crew of the steamer *Republic*, referred to a few pages back. When her wireless messages of distress were received a score of vessels went groping in the fog to her assistance, while the entire civilized world waited in breathless expectancy. Most of the rescuing vessels, although constantly in communication with the stricken ship, were unable to locate her. But the successful vessel finally got in touch with the *Republic's* submarine signaling apparatus, and aided by this located the vessel and rescued the crew and passengers.

This is only one instance of the practical application of the submarine signaling apparatus. But its use is not confined to the larger boats. The apparatus can be made so small that even boats the size of a fishing dory may be equipped at least with the sounding device, and thus protected.

On the Newfoundland fishing banks one of the chief causes of loss of life is the running down of the fishing boats in the fog by passing steamers, and also the loss of the dories of the fishermen who are unable to find their way back to their vessels. Many of these fishing vessels now supply each of the attending dories with a submarine bell which weighs about forty pounds and is run by clockwork. When caught in the fog the fisherman hangs this bell over the side of his dory and thus warns approaching steamers of his position, at the same time affording his own vessel a guide for finding him and picking him up. In this manner the appalling loss of life in the fogs on the fishing banks has been greatly lessened. Thus the submarine signaling device gives aid to the smaller craft as well as the larger vessels.

For the moment this is the last important safety device that has been invented to help lessen the perils of sea voyages. Indeed the perils and discomforts of ocean voyages are now largely reminiscent, thanks to the rapid succession of scientific discoveries and their practical application during the last half century. The size of modern vessels minimizes rolling and pitching. Turbine engines practically eliminate engine vibrations. The danger from fires was practically eliminated by the introduction of iron and steel as building material; the danger of sinking after collisions is now guarded against by the division of the ship's hull into water-tight

compartments; sensitive instruments as used at present warn the mariner of the presence of icebergs; wireless telegraphy affords a means of calling aid in case of disabled machinery and giving the ship's location in a general way; while the submarine signal makes known the exact location of the stricken vessel in foggy weather.

In a trifle over half a century the time of crossing the Atlantic has been reduced by more than one-half. In 1856 the *Persia* crossed the ocean between Queenstown and New York in nine days, one hour, and forty-five minutes, making a new record. In 1909 the *Mauretania* covered the same distance in four days, ten hours, and fifty-one minutes. In March, 1910, the same vessel completed a passage over the longer winter course, a distance of 2,889 knots, in four days, fifteen hours, and twenty-nine minutes, reducing the previous record by twenty-nine minutes.

90

When the *Lusitania* and *Mauretania* were completed many short-sighted persons predicted that these vessels would never be surpassed in size or speed. As if to refute such predictions, however, the White Star Company at once began constructing two vessels, the *Olympic* and *Titanic*, each with a displacement of one-fourth more than the great Cunarders, and of overshadowing proportions in everything save the matter of speed. Against the *Mauretania's* average twenty-six knot speed the new boats are designed to make only twenty-one.

These new boats are eight hundred and ninety feet in length, as against the *Lusitania's* seven hundred and ninety. They are ninety-two feet in beam, and sixty-two feet in molded depth. The roof of the pilot house is seventy feet above the water. The maximum draft is thirty-seven and a half feet and the displacement sixty thousand tons.

They resemble the *Great Eastern* in that they have two systems of engines. Two reciprocating engines drive the two outer of the three screws, and the exhaust from these engines is utilized in a low-pressure turbine engine, driving the center propeller.

LIQUID FUEL

Another step that has been taken to increase the efficiency of the steam engine on ships, is the adoption of liquid fuel in place of coal for making steam. For years the advantages of this form of fuel have been recognized, the Russians having brought its use to a high state of perfection, both in boats and locomotives. Practically all the steamers on the Black and Caspian seas, as well as on such rivers as the Volga, burn oil exclusively. And early in 1910 the British Navy decided to substitute oil for coal on all its vessels.

91

The advantages claimed for oil over coal as fuel are many. It is smokeless, produces more heat than coal, occupies less space for storage, can be loaded more quickly and easily, is cleaner, and reduces the engine-room force to one-fourth or one-third the number of men required when coal is used. Incidentally it reduces the difficult physical task of stoking to one relatively pleasant and easy. It gives a steadier fire, does not foul the boilers, and does away with cumbersome ashes and clinkers.

Its disadvantage lies in the danger from fire. An inflammable liquid carried in a ship's hold is obviously more dangerous than a corresponding quantity of relatively incombustible coal. Yet the obvious advantages of this form of fuel have been so compelling that it is now coming into use on all classes of war vessels, and seems likely to supplant coal entirely on some types of boats, such as the torpedo destroyers. Moreover, the experience of the Russian boats on the Black and Caspian seas seems to indicate that the dangers from the use of oil as a fuel when properly handled have been greatly exaggerated, and passenger and freight steamers all over the world are gradually adopting it.

Some tests were made by the Navy Department of the United States in 1909-1910 using a vessel which was formerly a coal-burning boat. In these tests it was found that the steaming radius was greatly increased, the firing force reduced, and fuel taken into the ship in about one-fourth the time it takes to coal. It was possible to get up steam in any boiler, or set of boilers, much more quickly than with coal.

92

Of course where oil is used for fuel some special form of burner is necessary. Many types have been tried, but in the most effective the oil is atomized by the use of steam spray, or air blast, it being impossible to get proper combustion of the oil except when used in minutely divided particles. Used in this manner a uniform temperature can be maintained easily, or may be increased or decreased very quickly.

As used at present liquid fuel simply substitutes coal for heating the ordinary type of boiler. But there seems every reason to believe that in the near future some type of internal combustion engine will be perfected that will use the crude, cheap oil, as the finer and lighter oils are used in motors to-day. When this occurs the space-consuming boilers and furnaces used in ships at present will be replaced by compact machinery, quite as efficient, but occupying only a fraction of the space. Nor need we expect that the invention of some such type of engine will be long delayed, if we may judge by the rapid strides made in perfecting other internal combustion engines during the past few years.

93

III

SUBMARINE VESSELS

THE development of submarine vessels has been one of the slowest in the history of modern inventions. Submarine boats, using submarine torpedoes, were able to destroy ships a hundred years ago; and a little less than half a century ago naval vessels were destroyed in actual warfare by these boats. But curiously enough no vessel has ever been destroyed in actual warfare by a submarine boat since that time. Yet these boats are essentially war-vessels, and, with the exception of boats of the Lake type, of no use whatever for commercial purposes.

Perhaps the explanation for this tardy development lies in the fact that until recent years naval men have not looked with favor upon this style of fighting craft. In Admiral Porter's book, written in 1878, he makes the statement that one of the reasons why they did not show more enthusiasm about the submarine made by Robert Fulton early in the nineteenth century, was that such boats "menaced the position of the naval men, whose calling would be gone did the little submarine boat supplant the battle-ship." We need not, however, depend upon this statement, made as it was three-quarters of a century after the demonstrations by Fulton, for there are many similar statements made at the time to be had at first hand. Thus Admiral Earl St. Vincent, when opposing the views of William Pitt, who had become enthusiastic over the possibilities of Fulton's submarines, is on record as having opposed such craft on the ground that by encouraging such development "he was laying the foundation which would do away with the navy." In 1802, M. St. Aubin wrote in this connection, "What will become of the navies, and where will sailors be found to man ships of war, when it is a physical certainty that they may at any time be blown into the air by diving boats, against which no human foresight can guard them?"

Such opposition has undoubtedly tended to retard the progress of submarine navigation; but be the cause what it may, it has made slow and laborious work of it; and we are only now approaching a solution of the question that seemed almost within grasp a hundred years ago—before the days of steam or electricity.

THE FIRST SUBMARINE

As early as the sixteenth century the possibilities of submarine navigation was the dream of the mariner, and tentative attempts at submarine boats are said to have been made even at an earlier period than this; but the first practical submarine boat capable of navigation entirely submerged for any length of time was made by David Bushnell, of Westbrook (then Saybrook), Maine, U. S. A., in 1775. Details as to the construction of the remarkable craft, are recorded in a letter written by the inventor to Thomas Jefferson in 1789, and recorded in the *Transactions of the American Philosophical Society*. In this letter Bushnell says:—

"The external shape of the submarine vessel bore some resemblance to the upper tortoise shells of equal size, joined together, the place of entrance into the vessel being represented by the opening made by the swell of the shells at the head of the animal. The inside was capable of containing the operator and air sufficient to support him thirty minutes without receiving fresh air. At the bottom, opposite to the entrance, was fixed a quantity of lead for ballast. At one edge, which was directly before the operator, who sat upright, was an oar for rowing forward and backward. At the other edge was a rudder for steering. An aperture at the bottom, with its valves, was designed to admit water for the purpose of descending, and two brass forcing-pumps served to eject the water within when necessary for ascending. At the top there was likewise an oar for ascending or descending, or continuing at any particular depth. A water-gauge or barometer determined the depth of descent, a compass directed the course, and a ventilator within supplied the vessel with fresh air when on the surface.

"The vessel was chiefly ballasted with lead fixed to its bottom; when this was not sufficient a quantity was placed within, more or less according to the weight of the operator; its ballast made it so stiff that there was no danger of upsetting. The vessel, with all its appendages and the operator, was of sufficient weight to settle it very low in the water. About two hundred pounds of lead at the bottom for ballast could be let down forty or fifty feet below the vessel; this enabled the operator to rise instantly to the surface of the water in case of accident.

"When the operator would descend, he placed his foot upon the top of a brass valve, depressing it, by which he opened a large aperture in the bottom of the vessel, through which the water entered at his pleasure; when he had admitted a sufficient quantity he descended very gradually; if he admitted too much he ejected as much as was necessary to obtain an equilibrium by the two brass forcing-pumps which were placed at each hand. Whenever the vessel leaked, or he would ascend to the surface, he also made use of these forcing-pumps. When the skillful operator had obtained an equilibrium he would row upward or downward, or continue at any particular depth, with an oar placed near the top of the vessel, formed upon the principle of the screw, the axis of the oar entering the vessel; by turning the oar one way he raised the vessel, by turning it the other he depressed it.

"An oar, formed upon the principle of a screw, was fixed in the fore part of the vessel; its axis entered the vessel, and being turned one way, rowed the vessel forward, but being turned the

other way rowed it backward; it was made to be turned by the hand or foot.

"Behind the submarine vessel was a place above the rudder for carrying a large powder magazine. This was made of two pieces of oak timber, large enough when hollowed out to contain one hundred and fifty pounds of powder, with the apparatus used in firing it, and was secured in its place by a screw turned by the operator. A strong piece of rope extended from the magazine to the wood screw above mentioned, and was fastened to both. When the wood screw was fixed to be cast off from its tube, the magazine was to be cast off likewise by unscrewing it, leaving it hanging to the wood screw; it was lighter than the water, that it might rise up against the object to which the wood screw and itself were fastened.

97

"Within the magazine was an apparatus constructed to run any proposed length of time under twelve hours; when it had run its time it unpinioned a strong lock resembling a gun-lock, which gave fire to the powder. This apparatus was so pinioned that it could not possibly move till, by casting off the magazine from the vessel, it was set in motion.

"The skillful operator could swim so low on the surface of the water as to approach very near a ship in the night without fear of being discovered, and might, if he chose, approach the stem or stem above the water with very little danger. He could sink very quickly, keep at any depth he pleased, and row a great distance in any direction he desired without coming to the surface, and when he rose to the surface he could soon obtain a fresh supply of air. If necessary, he might descend again and pursue his course.

"After various attempts to find an operator to my wish, I sent one who appeared more expert than the rest from New York to a fifty-gun ship lying not far from Governor's Island. He went under the ship and attempted to fix the wooden screw in her bottom, but struck, as he supposed, a bar of iron which passes from the rudder hinge, and is spiked under the ship's quarter. Had he moved a few inches, which he might have done without rowing, I have no doubt but that he would have found wood where he might have fixed the screw, or if the ship were sheathed with copper he might easily have pierced it; but not being well skilled in the management of the vessel, in attempting to move to another place he lost the ship. After seeking her in vain for some time he rowed some distance and rose to the surface of the water, but found daylight had advanced too far that he durst not renew the attempt. He says that he could easily have fastened the magazine under the stem of the ship above the water, as he rowed up to the stern and touched it before he descended. Had he fastened it there the explosion of one hundred and fifty pounds of powder (the quantity contained in the magazine) must have been fatal to the ship. In his return from the ship to New York he passed near Governor's Island, and thought he was discovered by the enemy on the island. Being in haste to avoid the danger he feared, he cast off the magazine, as he imagined it retarded him in the swell, which was very considerable. After the magazine had been cast off one hour, the time the infernal apparatus was set to run, it blew up with great violence."

98



ROBERT FULTON.

ROBERT FULTON'S EXPERIMENTS

The work begun by Bushnell in 1775 was taken up ten years later by Robert Fulton whose diving-boats so nearly fulfilled the conditions necessary for practical submarine navigation. As America was at peace at this time, and as her financial condition was at the lowest ebb, Fulton transferred his skill and energy to Europe which was then involved in the Napoleonic wars. Several attempts were made to interest the French government in his invention, but although certain commissions reported favorably on his ideas, nothing came of them for a time. In 1800,

99

however, Fulton succeeded in interesting Napoleon in his scheme, and the following year he was given the opportunity of building his first submarine boat, the *Nautilus*. This boat was cigar shaped, about twenty-one feet long and seven feet in diameter, and made of copper supported by iron ribs. When operating at the surface this boat used a peculiarly shaped sail; but when submerged it was propelled by a screw actuated by machinery turned by hand. In this boat, Fulton, with three companions, descended to a depth of twenty-three feet and remained submerged for twenty minutes; and at a depth of five or six feet they are said to have remained submerged for six hours, air being supplied by a copper vessel, probably containing oxygen or compressed air.

The first experiment made in attempting actually to destroy a vessel with the *Nautilus*, was successful, a small vessel being sunk. Encouraged by this success Fulton proposed to build larger boats of this same type capable of destroying the largest battle-ships. In return he asked that a reward be paid him for each vessel destroyed, the price of his diving boat reimbursed, and a patent be given himself and the members of his crew, so that in case of capture they would be treated as prisoners of war and not hanged as pirates. Strangely enough this latter clause was the greatest stumbling-block, as the proposed methods of destroying battle-ships by torpedoes was held in such disrepute that the French government would not grant a patent rating the crew of torpedo boats or submarine boats as legitimate belligerents. In effect, their attitude was, that while a person was at liberty to destroy an empire from the surface of the water, he would be hanged as a criminal if he dived beneath the surface and destroyed a boat.

100

Discouraged by this stand of the French government, Fulton removed to England, where he succeeded in interesting the prime-minister, William Pitt, in his novel boat. A commission was appointed consisting of a number of prominent men, including Mr. Pitt, and Fulton was requested to demonstrate what could be done in actual practice by his submarine. On October 15, 1805, an old brig detailed for the purpose was destroyed by Fulton by the explosion of a torpedo containing one hundred and seventy pounds of powder. Yet in the face of this remarkable demonstration the commission remained unfavorable to Fulton's scheme, although Mr. Pitt to the last retained his faith in the possibilities of such boats.

Recognizing that further attempts in England would be fruitless, Fulton returned to the United States. Here, in 1810, Congress became sufficiently interested to appropriate five thousand dollars to assist him in his work, and as a final test of the boat he had built, the naval authorities prepared the brig *Argus* to resist an attack by the submarine. This preparation consisted in surrounding her with protecting booms of logs, supporting strong netting, and held a distance from the hull by spars. In fact all possible means short of actually building a wall about the *Argus* were taken to defeat the attack. It is probable that the brig, when her preparations for defense were completed, would have been invulnerable even to a modern torpedo, and it is not surprising, therefore, that Fulton's attack upon her utterly failed.

101

Commenting upon this failure and the means taken by the authorities to protect the *Argus*, Fulton significantly remarked that the very fact that a war vessel was obliged to make use of such means to protect herself against a system of attack then in its infancy, spoke volumes for the possibilities of this method of attacking when it should be more fully developed.

But although this failure to destroy the *Argus* caused Congress to withdraw its aid for future experiments in submarine warfare, Fulton himself never lost faith in the importance of his work. Even after his successful invention of the steamboat, for surface navigation, he is said to have remarked that, while this invention was important, it could in no wise compare with the revolutionary effects upon navigation that would eventually be produced by submarine boats. And despite his failure to convince the government of the possibilities of his diving boats, he continued his experiments with them. How nearly he succeeded in making a practical submarine was shown in the second war with England that followed soon after.

In this war a "diving boat," supposed to have been one of Fulton's submarines, made several attacks upon the British man-of-war *Ramillies* off New London, in the summer of 1813. In the first two attempts the approach of the submarine was detected by the crew of the man-of-war, who cut their cables, and stood out of the harbor as quickly as possible. In the third attempt, the diving boat succeeded in coming up in a position directly under the *Ramillies*, fastened itself to the keel and made a hole in the planking large enough to receive the screw which was to fasten the torpedo in place. In the act of fastening it, however, this screw was broken off, and the attempt had to be abandoned for the moment.

102

This attack created such a panic aboard the British boat, that she did not return to the inner harbor but kept constantly in motion outside. Not satisfied with this protection against such "dishonorable attempts," the British commander took on board his vessel a hundred prisoners, apprising the Americans of the fact, and assuring them that a similar action would be taken by all the ships of the British fleet, so that in case a vessel was torpedoed the American prisoners would be blown up with her crew. This effectually frustrated Fulton's plans; for when the fact became known in the United States, the Americans were naturally as vigorous as the British in protesting against Fulton and his boats.

Obviously the rule that "everything is fair in war" was not accepted in practice a hundred years ago. Fulton's attempts were regarded as the acts of a pirate, those of the British commander as perfectly legitimate and honorable methods.

103

From the time of Fulton to the outbreak of the American Civil War there were few attempts at submarine navigation. On the opening of this war, however, efforts were made to perfect diving boats; and these efforts were so well directed that eventually one of these boats succeeded in destroying the Federal boat *Housatonic* in Charleston Harbor on the night of February 17, 1864.

The submarine that accomplished this was one of the most remarkable boats ever constructed. It was cigar shaped, about sixty feet long, and carried a crew of nine men. It was submerged partly by means of ballast tanks and partly by lateral fins. As a weapon it carried a spar torpedo fastened to its blunt nose. It was propelled by hand-power, eight of the nine members of the crew working on a crank which actuated the propeller. The ninth man, crouching in the bow, steered the boat. No reserve air was carried, and consequently the length of time the boat could remain submerged was limited to a very few minutes. On account of this, and because of its unfortunate career, it was aptly called the "peripatetic coffin"; and it justified this name by sinking five different times, drowning thirty-five out of forty of the members of its different crews. Nevertheless it succeeded in destroying an American war vessel, thus demonstrating that this feat is possible under condition of actual warfare.

The submarines of the Civil War came to be known by the general name of "Davids," and several of them of different types were built. The only successful attack of any of these Davids, however, was the one which destroyed the *Housatonic*. In his book, *The Naval History of the Civil War*, Admiral Porter described this attack upon the *Housatonic* as follows:—

104

"At about 8.45 P.M. the officer of the deck on board the unfortunate vessel discovered something about one hundred yards away, moving along the water. It came directly toward the ship, and within two minutes of the time it was first sighted was alongside. The cable was slipped, the engines backed, and all hands called to quarters. But it was too late—the torpedo struck the *Housatonic* just forward of the mainmast, on the starboard side, in a line with the magazine. The man who steered her knew where the vulnerable spots of the steamer were, and he did his work well. When the explosion took place the ship trembled all over as if by the shock of an earthquake, and seemed to be lifted out of the water, and then sunk foremost, heeling to port as she went down.

"Her captain, Pickering, was stunned and somewhat bruised by the concussion, and the order of the day was 'Sauve qui peut.' A boat was despatched to the *Canandaigua*, not far off, and that vessel at once responded to the request for help, and succeeded in rescuing the greater part of the crew.

"Strange to say the David was not seen after the explosion, and was supposed to have slipped away in the confusion; but when the *Housatonic* was inspected by divers, the torpedo-boat was found sticking in the hole she had made, and all her crew were dead in her. It was a reckless adventure these men had engaged in, and one in which they could scarcely have hoped to succeed. They had tried it once before inside the harbor, and some of the crew had been blown overboard. How could they hope to succeed on the outside, where the sea might be rough, when the speed of the David was not over five knots, and when they might be driven out to sea! Reckless as it might be, it was the most sublime patriotism, and showed the length to which men could be urged on behalf of a cause for which they were willing to give up their lives and all they held most dear."

105

RECENT SUBMARINES AND SUBMERSIBLES

After the Civil War several nations interested themselves in the subject of submarines, and during the Franco-Prussian war in 1870-71, France attempted the construction of such vessels, but without success. Yet the possibility of producing these boats was becoming more apparent every year by the improvements in electrical motors, gasoline engines, compressed-air motors, and the automobile- or fish-torpedo—itsself a miniature submarine boat.

In America the progress made in submarine-boat construction has been fully as great, if not greater, than in any other country. Undoubtedly the foremost figure in this progress has been Mr. P. Holland; and his efforts and successes are largely responsible for the present fleet of submarine boats built already, or in the process of construction, as well as for those of several foreign countries. Indeed, in the matter of submarine inventions, only one country can be considered as rivaling America, that nation being France, whose enthusiasm for submarine navigation has been much greater than that of any other nation, although in the matter of results she has not outstripped the United States.

106

Mr. Holland's first submarine boat was built in 1875. It was called a "diving canoe," being only sixteen feet in length and wide enough to hold one man clothed in a diving-suit. Four years later, however, Holland built a larger boat called the *Holland No. 3* constructed along similar lines to the most recent submarines. This was the first buoyant submarine to be steered up and down by horizontal rudders alone, and may be said to mark an epoch in submarine navigation. But the No. 3 had many defects, and Mr. Holland continued to build and improve new boats, until finally his ninth boat, which is the one familiarly known as the *Holland*, represented a practical form of submarine vessel. This boat was 53 feet 10 inches long, 10 feet 3 inches in diameter, had a displacement of 75 tons, and carried 10 tons of water ballast. The gasoline engine which it used when running at the surface propelled the boat at the rate of seven knots an hour, and it could travel a distance of fifteen hundred miles at this rate of speed with the amount of fuel carried. When submerged it could run a distance of about fifty knots without coming to the surface.

In diving, the Holland type of boat takes in sufficient water ballast to lower it to the surface of the water. The horizontal rudders are then brought into use causing it to descend to the desired depth, and keeping it at an approximately uniform distance from the surface while running submerged. By this arrangement the boat can dive very quickly, requiring only a matter of eight or ten seconds for reaching a depth of thirty feet. Record plunges have been made in less time than this.

The armament of the Holland boat was originally designed to consist of three tubes, two of which were for throwing aerial torpedoes and shells, and the third for discharging Whitehead torpedoes. One of these aerial guns was placed in the bow, and one in the stem; but later the stern tube was abandoned. The bow gun was designed to discharge projectiles a distance of about one mile, such projectiles weighing something over two hundred pounds and carrying one hundred pounds of gun-cotton. The tube for discharging the Whitehead torpedo was practically the same as the submerged tubes in use at present on battle-ships.

Although this *Holland* is now the type of diving boat most familiar to the majority of people, and the one in use in several navies, it should not be understood that the Holland boats were the only successful submarines constructed up to this time. France and Russia had produced successful diving boats; and in America those invented by Simon Lake, some of which are used for wrecking and salvage work as well as for war purposes, have proved quite as practical as the Hollands. In recent tests of these two types by the United States Government the Holland boats showed themselves to be slightly superior to the Lake boats in certain particulars, but the margin of superiority was a very narrow one.

The boats of the "Octopus" type are strictly speaking "diving boats," while the Lake boats are of the "even-keel" type. These terms refer to the method of submergence, the diving boats changing their horizontal trim when submerging, while the even-keel boats retain their horizontal trim, or nearly so.

The Lake boats have some features not usually embodied in other submarines, since some of the boats are designed for purposes other than warfare. Thus, they are equipped with wheels, or buffers, on which they can roll along the bottom of the ocean or bay. In the bow is an air-tight compartment with an opening in the bottom through which a diver can emerge and work on wreckage, or laying and disconnecting mines. These boats have also a safety device in the form of a detachable keel weighing several tons. In case of accident, when it might otherwise be impossible to rise to the surface, this keel can be detached simply by pulling a lever, thus giving the boat sufficient buoyancy to rise to the surface. This particular feature of the detachable keel is not peculiar to the Lake boats alone, some of the foreign submarines using a similar arrangement as a safeguard.



THE AMERICAN SUB-MARINE BOAT "CUTTLEFISH" IN DRY DOCK AT THE BROOKLYN NAVY YARD.

Technically speaking the name "submarine" is now used only as applying to those boats that are operated solely by electric power, have little buoyancy, and do very little running at the surface. The term "submersible" is applied to a submarine boat, actuated by electricity while submerged, but using gasoline motors for motive power while running at the surface. These gasoline engines are used at the same time for charging the storage batteries; so that the submersible is a much more practical boat than the submarine, and at the same time is quite as good a diver. Indeed, although many naval writers are very careful to make a distinction in the use of these terms, there seems little need of doing so, since only one type of boat—the submersible—is now considered practical. But as the word submarine is the older and more popular, it is used here to cover both classes except in specific cases.

For several years there were two classes of submarines under observation—those possessing no floatability when submerged, and those having some reserve buoyancy. The advantage

claimed for the no-floatability class of boats is that, having no buoyancy, they are kept more easily at a certain depth below the surface of the water instead of tending to come to the surface constantly as in the case of boats of the other type.

But in actual practice the theoretical possibilities of such boats have not come up to the expectations of their advocates. For keeping the boat at a uniform depth, the most universally accepted method is by the use of horizontal rudders. The fact that the vertical direction of a boat may be controlled by horizontal rudders, when her buoyancy is small, has long since been established in submarine navigation; and the simplicity of this method naturally helps its popularity. If there were no shifting of weight in a submarine, or no wave disturbance, it would not be difficult to set the rudders at such an angle that the boat would travel for long distances at an approximately uniform submergence, the depth of submergence being indicated by gauges acted upon by the water pressure on the surface of the boat. And in actual practice it is possible to do this at the present time, part of the problem having been solved by automatic and other devices.

110

It should be remembered that many things enter into the disturbance of the submarine's equilibrium. The movement of a member of the crew from one point to another shifts the ballast; a certain amount of leakage of water cannot be avoided, and the sudden discharge of a torpedo weighing several hundred pounds from her bow tends to bring the boat quickly to the surface if this lost weight is not compensated for quickly. By various ingenious devices all these difficulties have been practically overcome, most of them automatically.

But the great unsolved problem of submarine navigation—practically the only one that now opposes a question mark to its great utility in warfare—is that of steering with certainty of direction when submerged. Once the submarine is under water it is in utter darkness as far as seeing to steer is concerned; and what adds to the difficulty is the fact that the compass cannot be relied upon, because of the surrounding electrical apparatus. It would be possible, perhaps, to construct a powerful electric lamp to throw a light some distance ahead of the boat, but this would defeat the primary object of submarine attack, as such a light would be seen by an enemy.

111

In still water, when the boat is running within a distance of ten or fifteen feet of the surface, it is possible to steer with great precision by the use of an optical tube or "periscope." This periscope is a straight, hollow tube, connected with the steering compartment in the submarine, and protruding above the water. In the upper end are a mirror and lenses so arranged that the surrounding objects are reflected downward through the tube, and show on a screen, or some other device, so that the helmsman sees things of exactly the same size that they would appear to the naked eye. The periscope is also fitted with a telescope attachment which magnifies objects like the binoculars used in surface navigation. On some recent submarines there are two periscopes, a movable one for use of the commanding officer, and one that looks straight ahead for the helmsman's use.

In still water the periscope works admirably, but it is seriously interfered with even by small waves. It is so small and inconspicuous, however, that it might enable a submarine to creep within torpedo range even in daylight, and launch the torpedo with accuracy, as was proved in 1908 when a fleet of submarines actually accomplished this feat in an experimental test.

PRESENT STATUS OF SUBMARINE BOATS

To most people, one of the most surprising things in the Russo-Japanese war was the fact that submarine boats played no part in it whatever. There is only one possible conclusion to be drawn from this: the day of the submarine as a determining factor in naval battles on the high seas had not arrived.

112

The reason for the surprise of the generality of people in finding the submarine was not as yet an entirely practical war engine, is due to the enthusiastic misrepresentations of the daily press and magazines, whose readers have been led to infer that the modern submarine boat is so far perfected that it can do things under water almost as well as boats on the surface. Nothing is farther from the truth. Under ideal (and consequently unusual) conditions, the submarines, and submersibles, have done, and can do, some remarkable things, such as staying submerged for hours, diving to a depth of two hundred feet, and running long distances. But these are only the first requisites of the under-water fighting boat—simply the "creeping stage" of development. The common impression that the submarine boat, such as the ones of the Holland and Lake types, can go cruising about, fish-like, for hours, watching for its prey in some mysterious manner without coming near the surface, is a dream not yet realized.

If one will pause to consider that light is necessary to sight and that one hundred feet of sea water makes almost as efficient an obstacle to vision as a stone wall, it will be easy to understand why the submarine is still struggling with difficulties that oppose its perfection. The fanciful illustration seen so often of a submarine diving hundreds of feet deep in the water, swimming about and finally coming up under the keel of a battle ship and destroying it, are as yet the creations of vivid imaginations. For submarine marksmen, like all others, require a fairly clear view of the target—even such a huge target as a battle-ship—to direct their shots with any degree of certainty.

113

The greatest problem now confronting the submarine navigator, therefore, is that of seeing without being seen. At night, and at long ranges, this is not difficult, as the little conning-tower, or tiny periscope tube protruding above the waves, is not easily detected even by strong

searchlights, sharp eyes, and marine glasses. But long ranges are of little use to the submarine; and there is always another difficulty—the leviathan battle-ship does not lie still waiting to be stabbed by its sword-fish enemy, but keeps moving about, twisting and turning, at a rate of from fourteen to eighteen knots an hour, while the submarine can only make about eleven knots when submerged. In a stern chase, therefore, the submarine is one of the most harmless of sea-monsters, in the open ocean. For harbor work, however, the case is different. In some recent tests the submarine boats made eighty per cent. in hits while attacking moving vessels in a harbor at night—a far higher percentage than is usually made by surface torpedo boats under the same circumstances.

At present the best solution of the problem of steering the partly submerged submarine is offered by the use of a conning-tower elevated five or six feet above the body of the submarine, which can be kept just above the waves, and present an inconspicuous target. The early Holland boats did not have this, although the American Lake boats have had it from the first; but at the present time all boats are being so made. At first these towers were made circular in form; but it was found that towers of this shape made sufficient splash in passing through the water to attract attention at a considerable distance on a still night. This shape was abandoned, therefore, and a boat-shaped one adopted.

114

With such a noiseless conning-tower the submersible can cruise about on foggy nights, or when the waves are just high enough to make a disturbance on the surface, running with the top of the conning-tower open so as to secure good ventilation as long as possible, until the enemy is nearly within striking distance. As the target is approached the conning-tower must be closed, the protruding top sunk lower and lower in the water, and finally completely submerged, nothing appearing at the surface but the periscope tube just above the waves. With the aid of this instrument the target may still be seen distinctly, but the arc of vision is limited, and guessing the distance or rate of speed of the target is very difficult. Nevertheless, by estimating the distance before submerging, and knowing the rate of speed of his little craft, the submarine gunner may still get his range and find his target. If the waves are at all high, this is very difficult, as the water, slopping over the periscope, obscures the vision for several seconds at a time and is very distracting. But some experiments carried on during the summer of 1908 show that, even in broad daylight, it is no easy matter for a battle-ship to detect the approach of submarines until well within torpedo range, even when an attack is expected.

115

In these experiments the United States cruiser "Yankee" in Buzzard's Bay was attacked by five submarines of the most recent type. The "Yankee" remained stationary expecting the attack, but to offset this disadvantage the crew was fully aware of the exact time that the attack was to be made. Indeed the officers of the cruiser had watched the submarines steam away until they disappeared. When twenty miles from the "Yankee" the five submarines submerged and headed for the cruiser, making observations at intervals by means of the periscope.

The day was perfectly clear, and all on board the "Yankee" were keenly watching for the expected submarines. Yet the first intimation they had of the proximity of the diving boats was the striking of five torpedoes against the cruiser's hull. Each submarine had scored a bull's-eye. Not content with this success, the submarines repeated the attack from a nearer point, again scoring five hits before their presence was detected.

One great obstacle to successful submarine navigation on an extended scale is the difficulty of keeping a supply of air not only for the use of the crew, but for the engines. Any really powerful engine, either steam or gas, consumes an enormous amount of air. This is not true, of course, of the storage batteries which furnish the power for running while submerged, but these, at best, are but feeble generators of energy, although Edison's recent improvements may materially improve their power. If gasoline engines could be used during submergence a far greater speed would be acquired; but this is out of the question, as such engines would consume the air supply of the little boat far too rapidly. The compromise, now adopted universally, is to use gasoline motors while running at the surface or partly submerged, when the conning-tower is open, utilizing part of their energy meanwhile to charge the storage batteries.

116

It is evident, therefore, that no great speed can be expected of the submarine in its present state; and in point of fact the largest type is able to develop only about ten or eleven knots when submerged, and fifteen while at the surface—far below the speed of any other type of war vessel. But the experimental attacks upon the "Yankee" prove that they are dangerous fighting craft, and a recent voyage by a flotilla of Italian submersibles shows that such boats are no longer harbor-locked vessels. In 1908 the Italian flotilla in question made a voyage from Venice to Spezia, a distance of thirteen hundred miles, without assistance from auxiliary boats. About the same time a British submarine flotilla, on a three-hundred mile trip, remained submerged for forty consecutive hours. The depth of the submergence in this case was only a few feet, but great depths may be reached with relative safety. In one test a Lake boat carrying her crew sank to a depth of one hundred and thirty-eight feet, returning to the surface in a few minutes. At another time the "Octopus," without her crew, was lowered to a depth of two hundred and five feet, sustaining a pressure of fifteen thousand tons, without injury.

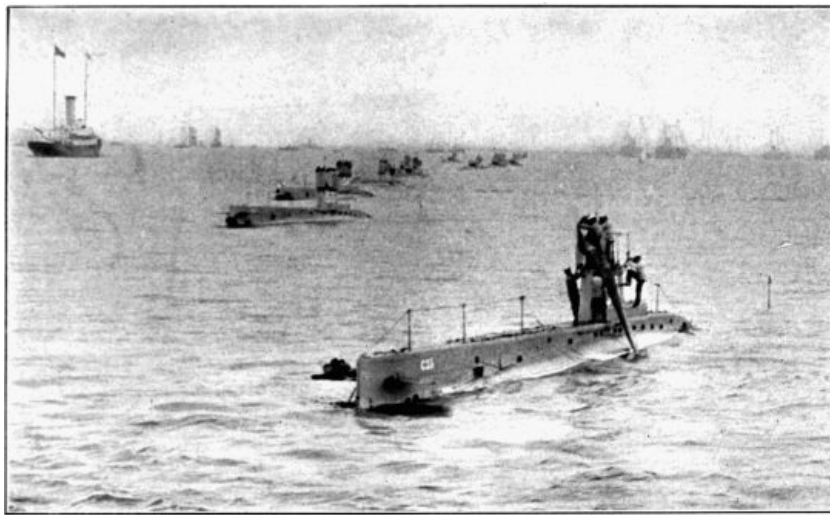

A FLEET OF BRITISH SUB-MARINES MANŒUVERING AT THE SURFACE.

Such performances as these are thought-provocative, to say the least. Submarine boats that can hit the target without being detected, go on cruises unattended for more than a thousand miles, and remain submerged for more than a day and a half, must be classed as efficient engines of warfare.

117

Since the submersible is designed to spend most of its time on the surface of the water like an ordinary boat, it must have considerable buoyancy, but it must also have some means of getting rid of this buoyancy quickly when submergence is necessary. The submarine proper has only from five to eight per cent. buoyancy, while some of the submersibles have twenty-five per cent. or more. With such boats of the ordinary size some fifty tons of water must be admitted before bringing them to a condition in which they can be submerged; but this can be done very quickly. One of the submarines of the U. S. fleet in an actual test filled her ballast tanks and dived to a depth of twenty feet in four minutes and twenty seconds.

It is not impossible that the recent triumphs in aërial navigation may have an important bearing on the use of submarines in future wars. It is well known that large objects when submerged even to a considerable depth are discernible from a height in the air directly above them. It is quite possible, therefore, that swift aeroplanes circling about a fleet of war vessels might be able to detect submarine boats when these boats were near enough the surface to use their periscopes. If so it might be possible for the aeroplanes to drop torpedoes upon the submerged boats without danger to themselves. Or if the aeroplanes carried no effective weapons, they could at least act in the capacity of scouts and warn their battleship consorts of the presence of the submarine. Of course, this would be possible only in daylight, the airships giving no protection against night attacks.

118

119

THE STEAM LOCOMOTIVE

MODERN railroads are the outcome of the invention of the locomotive; yet the invention of the practical locomotive was the outcome of iron railroads which had been in existence for half a century. These iron railroads were a development from wooden predecessors, which were the direct descendants of the smooth roadways of the Greeks and Romans. Indeed it is quite reasonable to suppose that the ancients may have been familiar with the use of parallel rails with grooved or flanged wheels to fit them; but if so there seems to be no definite record of the fact, and our knowledge of true railroads goes back only to the seventeenth century.

As early as 1630, it is recorded that a road built of parallel rails of wood upon which cars were run was used in a coal-mine near Newcastle, England; and there is no reason to suppose that this road was a novelty at the time. Half a century later there was a railroad in operation near the river Tyne which has been described by Roger North as being made of "rails of timber placed end to end and exactly straight, and in two parallel lines to each other. On these rails bulky cars were made to run on four rollers fitting the rails, whereby the carriage was made so easy that one horse would draw four or five chaldrons of coal to a load."

120

At this time the use of iron rails had not been thought of, or at least had not been tried, probably from the fact that iron was then very expensive. Even the wooden rails in use, and the wheels that ran upon them, were of no fixed pattern. Some of these rails were in the form of depressed grooves into which an ordinary wheel fitted. But these were very unsatisfactory because they became filled so easily with dirt and other obstructions, and a more common type was a rail raised a few inches above the ground like a molding, a grooved wheel running on the surface.

Such rails were short lived, splitting and wearing away quickly, and being easily injured by other vehicles. But they were, on the whole, more satisfactory than the depressed rails, and were the type adopted when iron rails first came into use, about 1767. Ten years later the idea of the single flange was conceived, not placed on the wheels of the cars as at present, but cast on the rails themselves. These flanges were first made on the outside of the rails, and later placed on the inside, the wheels of the cars used on such rails being of the ordinary pattern with flat tires.

But, in 1789, William Jessop, of Leicestershire, began building cars with wheels having single flanges on the inside like modern car wheels, to run upon an elevated molding-shaped iron rail; and the many points of superiority of this type of wheel soon led to its general adoption. So that aside from some minor changes, the type of rails and wheels in use at the close of the eighteenth century was practically the same as at present.

121

It is probable that if the first inventors had attempted to make locomotives to run upon the railroads then in existence they would have been successful many years before they were, but the advantages of railroads was not as evident then as now, and the inventors' efforts were confined to attempts to produce locomotive wagons—automobiles—to operate upon any road where horses and carts could be used.

Some of their creations were of the most fanciful and impractical design, although quite a number of them were "locomotives" in the sense that they could be propelled over the ground by their own energy, but only at a snail's pace, and by the expenditure of a great amount of power. Several inventors tried combining the principle of the steamboat and the locomotive in the same vehicle, and in 1803 a Philadelphian by the name of Evans made a steam dredge and land-wagon combined which was fairly successful in both capacities of boat and wagon. He called his machine the "Oruktor Amphibious," and upon one occasion made a trip through the streets of Philadelphia, and then plunged into the Schuylkill River and continued his journey on the water. But as he was unable to arouse anything but curiosity, the financiers refusing to take his machine seriously, he finally gave up his attempts to solve the problem of steam locomotion.

The year before this, in 1802, Richard Trevithick, in England, had been more successful in his attempts at producing a locomotive. He produced a steam locomotive that operated on the streets of London and the public highways, hauling a wagonload of people. But the unevenness of the roads proved disastrous to his engine, and as it could make no better time than a slow horse, it was soon abandoned. But Trevithick had learned from this failure that a good roadbed was quite as essential to the success of a locomotive as the machine itself, and two years later he produced what is usually regarded as the first railway locomotive. This was built for the Merthyr-Tydvil Railway in South Wales, and on several occasions hauled loads of ten tons of iron at a fair rate of speed. It was not considered a success financially, however, and was finally abandoned.

122

At this time a curious belief had become current among the inventors to the effect that if a smooth-surface rail and a smooth-surface wheel were used, there would not be sufficient friction between the two to make it possible to haul loads, or more than barely move the locomotive itself. Learned mathematicians proved conclusively on paper by endless hair-splitting calculations that the thing was impossible,—that any locomotive strong enough to propel itself along a smooth iron rail would be heavy enough to break the strongest rail, and smash the roadbed. In the face of these arguments the idea of smooth rails and smooth wheels was abandoned for the time. Trevithick himself was convinced, and turned his attention to the perfecting of an engine with toothed drive-wheels running on a track with rack-rails. But this engine soon jolted itself and its

track into the junk-heap without doing anything to solve the problem of locomotion.

Shortly after this, a man named Chapman, of Newcastle, built a road and stretched a chain from one end to the other, this chain being arranged to pass around a barrel-wheel on the locomotive, which thus pulled itself along, just as some of the boats on the Rhine do at the present time. But the machinery for operating this engine was clumsy and unsatisfactory, and the road proved a complete failure.

123

Perhaps the most remarkable locomotive ever conceived and constructed was one built by Brunton, of Derbyshire, in 1813. This machine was designed to go upon legs like a horse, and was a combination of steam wagon and mechanical horse. The wagon part of the combination ran upon a track like an ordinary car, while the mechanical legs were designed to trot behind and "kick the wagon along." "The legs or propellers, imitated the legs of a man or the fore-legs of a horse, with joints, and when worked by the machine alternately lifted and pressed against the ground or road, propelling the engine forward, as a man shoves a boat ahead by pressing with a pole against the bottom of a river." This machine was able to travel at a rate somewhat slower than that at which a man usually walks; and its tractive force was that of four horses. But after it had demonstrated its impotency by crawling along for a few miles, it terminated its career by "blowing up in disgust," killing and injuring several by-standers.

The much disputed point as to whether a smooth-wheeled locomotive would be practical on smooth rails was not settled until 1813. An inventor named Blckett, of Wylam, who with his engineer, William Hedley, had built several steam locomotives which only managed to crawl along the tracks under the most favorable conditions, wishing to determine if it were the fault of locomotives or the system on which they worked that accounted for his failures, constructed a car which was propelled by six men working levers geared to the wheels, like the modern hand-car.

124

In this way he determined that there was sufficient adhesion between smooth rails and smooth wheels for locomotives to haul heavy loads behind them, even on grades of considerable incline. The experiments of Blckett settled this question beyond the possibility of controversy, and removed a very important obstacle from the path of future inventors. Among these inventors was young George Stephenson, who was rapidly making a reputation for himself as a practical engineer.



GEORGE STEPHENSON

STEPHENSON SOLVES THE PROBLEM

Stephenson was born on June 9, 1781, in the small colliery village of Wylam, on the river Tyne. His parents were extremely poor, and as the boy was sent to work as soon as he was large enough to find employment of any kind, he was given no education, even to the extent of learning the alphabet. It was only after he had spent many years in the colliery, and had finally worked himself up from the position of "picker" at three pence a day to that of fireman, that he was able to spend the necessary time and pennies to acquire something of an education. Then he attended

125

a night school, learned his alphabet, was able to scrawl his name at eighteen years of age, and a little later could read, write, and do sums in arithmetic.

But if deficient in letters, there was one field in which he had no superior,—that was in the practical handling of a steam-engine. His position in the mine gave him a chance to study the workings of the engines then in use, and at every opportunity, on holidays and after working-hours, he was in the habit of dismantling his engine, and carefully studying every detail of its construction. Thus by the time he had reached his majority he was a skillful engineer, besides having many new ideas that had developed during his examinations of the machinery. But besides his knowledge of engineering, he was an accomplished workman in other fields. He was a good shoemaker, watch-and clock-repairer, and tailors' cutter, at all of which trades he worked at odd times to increase his income. Thus he was a veritable jack-of-all-trades; with the unusual qualification, that he was master of *one*.

By the time he was twenty-six years old he was holding the position of engineer to a coal-mining company, and had acquired the confidence of his employers to such an extent that he was permitted to build a locomotive for them—a thing that had been his ambition for several years. This was in 1807, the same year that Robert Fulton demonstrated the possibilities of steam navigation.

In the construction of this engine Stephenson introduced several novel features of his own inventing, although on the whole no new principles were involved; and in practice this engine showed several points of superiority over its predecessors. It would draw eight loaded wagons of thirty tons' weight at the rate of four miles an hour on an ascending grade of one in four hundred and fifty feet. But it had two very radical defects—it would not keep up steam and the noise of the steam-pipe exhausting into the open air frightened the horses of the neighborhood to such a degree that the authorities ordered the inventor either to stop running his engine, or suppress its noise. As an experiment, therefore, Stephenson arranged the exhaust pipes so that they opened into the smokestack, where the sound would be muffled. But when the engine was now tried he found to his surprise that this single expedient had solved both difficulties, the exhausting steam causing such an improvement in the draught of his furnace that double the quantity of steam was generated. This discovery helped to simplify later experiments, for the difficulty of keeping up steam had been one of the great obstacles encountered by the inventors.

126

Stephenson's second locomotive was an improvement over his first in many ways, but it was still far from being the practical machine that was to supplant horse-power. It could haul heavier loads than teams of horses, and was more convenient for certain purposes; but it was no more economical.

As yet the only use to which locomotives had been put was that of hauling cars in coal-mines. Indeed, the only railroads then constructed were those used in mines, the idea of utilizing such roads for passenger and freight traffic not having occurred to anyone until about 1820. Then the Englishman, Thomas Gray, suggested the construction of such a road between Liverpool and Manchester, advocating steam as the motive power. His idea was looked upon as visionary, and as he persisted in his efforts to interest prominent people in the scheme, he came to be very generally regarded as an enthusiastic but somewhat crackbrained fanatic.

127

But meanwhile the coal railroads were being extended to such lengths that they were assuming the proportions of modern railroads. The motive power on most of the roads was horses, although here and there a traction engine using chain or cable, was employed for certain purposes. In 1825, however, Stephenson began the construction of an improved locomotive, this time at his own modest establishment; and a little later this engine made the trial that really demonstrated the possibilities of steam locomotion, although this was not universally recognized until the success of the *Rocket* a few years later.

A great deal of excitement and speculation arose throughout the country when the trial day approached. Great crowds assembled from every direction to witness the trial; some, more sanguine, came to witness the success, but far the greater portion came to see the bubble burst. The proceedings began at Busselton incline, where the stationary engine drew a train up the incline on one side and let it down on the other. The wagons were then loaded.

"At the foot of this plane a locomotive, driven by Mr. Stephenson himself, was attached to the train. It consisted of six wagons loaded with coal and flour, next a passenger coach (the first ever run upon a railroad) filled with the directors and their friends, then twenty wagons fitted up with temporary seats for passengers, and lastly came six wagons loaded with coal, making in all twenty-eight vehicles. The word being given that all was ready, the engine began to move, gradually at first, but afterward, in part of the road, attaining a speed of twelve miles an hour. At that time the number of passengers amounted to four hundred and fifty, which would, with the remainder of the load, amount to upwards of ninety tons. The train arrived at Darlington, eight and three-quarter miles, in sixty-five minutes. Here it was stopped and a fresh supply of water obtained, the six coal-cars for Darlington detached, and the word given to go ahead. The engine started, and arrived at Stockton, twelve miles, in three hours and seven minutes including stoppages. By the time the train reached Stockton the number of passengers amounted to over six hundred."

128

From this description it will be seen that the coal roads had been extended to form interurban railways. In this connection it is interesting to note the increase of traffic that developed on this particular road in the years immediately following the invention of the practical locomotive. When the road was projected it was estimated that its maximum carrying capacity would not exceed 10,000 tons of coal yearly. A few years later, when locomotives had come into use, the

regular yearly carriage amounted to 500,000 tons.

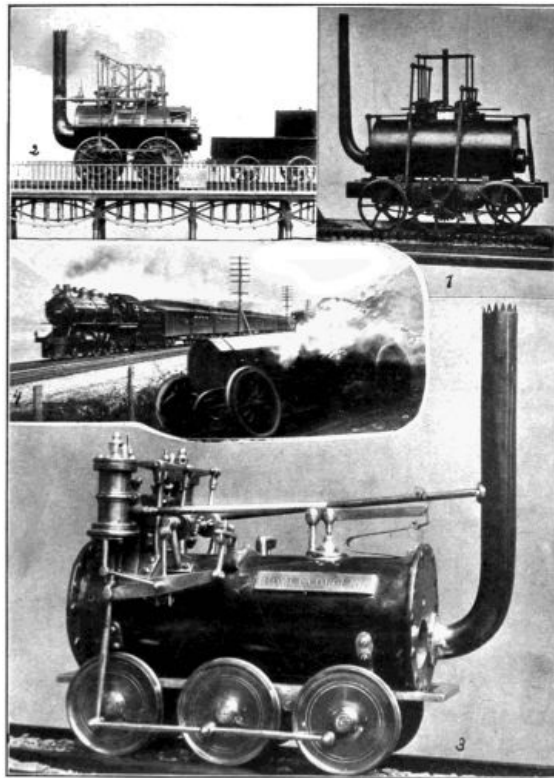

A CENTURY'S PROGRESS IN LOCOMOTIVE BUILDING.

Fig. 1.—The Blenkinsop locomotive, built in 1812-13 to work on the rack Railway between Leeds and the Middleton colliery, a distance of 3.5 miles. This was the first commercially successful enterprise in which steam locomotives were employed. Fig. 2.—Model of locomotive engine No. 1 of the Stockton and Darlington Railway, England, built by Messrs R. Stephenson & Company in 1825. This engine ran successfully for 21 years. Fig. 3.—The locomotive "Royal George" which worked on the Stockton and Darlington Railway 1827-1842. It will be observed that each of these engines antedated Stephenson's famous "Rocket." Fig. 4.—Shows, by way of contrast with these earliest types of locomotive, the "Twentieth Century Limited" train of the New York Central Railroad, and a racing automobile, either of which can easily make better time than a mile a minute, as against the two or three miles per hour of their prototypes.

The passenger coach on this first train, the first of its kind ever constructed for the special purpose of carrying passengers, was remarkable for its simplicity. One writer described it as "a modest and uncouth-looking affair, made more for strength than for beauty. A row of seats ran along each side of the interior, and a long table was fixed in the centre, the access being by the doorway behind, like an omnibus. This vehicle was named the *Experiment*, and was the only carriage for passengers upon the road for some time."

129

About this time the now famous Liverpool and Manchester Railway was projected. It was elaborately planned and carried out at an enormous expense. The construction of the road-bed was given special attention, although as yet the question of what motive power should be used had not been decided. Most of the directors and engineers favored the use of horses. The few that were in favor of steam did not favor the use of locomotives, but a system that would now be called a relay-cable system. According to this plan the road of about thirty miles was to be divided into nineteen sections, over each of which a stationary steam-engine was to work a chain or cable. But when the board of engineers appointed to investigate the possibilities of this system reported on the matter, it was found that there were several vital defects in such a system. For example, should any one of the sections of cable break or become inoperative, the entire line would have to stand idle; and furthermore, the cost of building and maintaining these nineteen stations offered serious financial obstacles.

It is an interesting fact that until the report of this board was made "not a single professional man of eminence could be found who preferred the locomotive over the fixed engine, George Stephenson only excepted." But with the glaring defects of the cable road, and the enormous cost of maintenance impressed upon the directors, the idea of the locomotive became at once more attractive, and the performance of Stephenson's locomotive was more carefully investigated. The upshot of these investigations was the offer of a prize of £500 for a locomotive that, on a certain day would perform certain duties named under the eight following headings:—

130

1. The engine must effectually consume its own smoke.
2. The engine, if of six tons' weight, must be able to draw, day by day, twenty tons' weight,

including the tender, and water-tank, at ten miles an hour, with a pressure of steam upon the boiler not exceeding fifty pounds to the square inch.

3. The boiler must have two safety-valves, neither of which must be fastened down, and one of them completely out of the control of the engineer.

4. The engine and boiler must be supported upon springs and rest on six wheels, the height of the whole not exceeding fifteen feet to the top of the chimney.

5. The engine with water must not weigh more than six tons, but an engine of less weight would be preferred although drawing a proportionately less load behind it; if of only four and one-half tons it might be put on four wheels.

6. A mercurial gauge must be affixed to the machine, showing the steam pressure about forty-five pounds to the square inch.

7. The engine must be delivered, complete and ready for trial, at the Liverpool end of the railway, not later than October 1, 1829.

8. The price of the engine must not exceed £550.

What strikes one as most peculiar in this set of requirements and specifications is the first clause—that of the engine consuming its own smoke; for even at the present time this is considered a difficult problem. But this was not so considered by the inventors of that time, their great stumbling-block being the high speed required. Ten miles an hour struck most of them as absurd and out of the question.

One eminent person, who was to become later one of England's leading engineers, stated publicly that "if it proved to be possible to make a locomotive go ten miles an hour, he would undertake to eat a stewed engine-wheel for his breakfast." It is not recorded whether or not this terrible threat was carried out.

But there was more than one engineer and engine-builder who took a more sanguine view of the prize offer. The firm of Braithwait & Ericsson signified its intention of competing, with a locomotive that they named the *Novelty*. Another firm entered the contest with an engine called the *Sans-pareil*; still another firm entered the *Perseverance*; and George Stephenson was on hand with the now-famous *Rocket*.

In the series of trials that followed, the *Sans-pareil* and the *Perseverance* were so clearly outclassed by the other two competing locomotives that they need not be considered here; but the *Novelty* and the *Rocket* were close competitors. The *Novelty*, indeed, made such a good showing, and afterwards proved to be such a good locomotive, that although it lost the contest, many competent judges have since regarded it as equal to the *Rocket*, if not superior, in principle. Be that as it may, later experiments proved conclusively that the cause of failure on the final day of the prize contest was due to defects in workmanship rather than to defective principle of construction.

The *Novelty* has been described as having the appearance of "a milk-can set in the rear end of a wagon, with a little smokestack in front looking like a high dashboard." It carried its supply of fuel and water in the "wagon-box" part of the engine frame, in front of the boiler, so that it required no tender. On its first trial, running without any load, it reached a speed of twenty-four miles an hour—a speed more than double the "stewed engine-wheel" limit. But at each subsequent trial, although it hauled loads for short distances, some part of its machinery became disabled, so that it was necessarily regarded as inferior to its more stable rival, the *Rocket*.

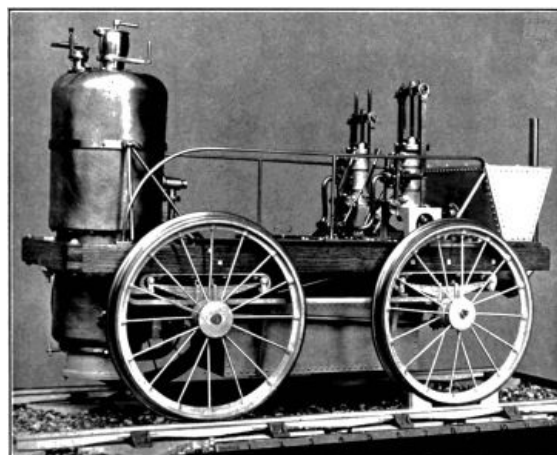
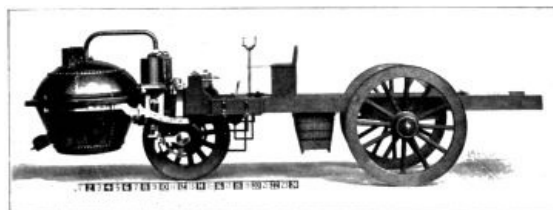

These vehicles are shown together here because of their similarity of plan of construction. Cugnot's original engine (upper figure) was built in France in 1769. The vehicle shown above was made in 1770, after Cugnot's designs, for the French Government. It was intended for the transportation of artillery, and the specifications called for a carrying capacity of about 4-1/2 tons and a speed of 2-1/4 miles per hour on level ground. Cugnot's original engine had attained this speed on a common road while carrying four persons; notwithstanding which fact the machine above shown was for some reason never given a trial. It is now preserved in the Conservatoire des Arts et Metiers, in Paris. It is particularly noteworthy that the successful road engine of Cugnot was constructed in 1769, the year in which James Watt took out the first patents on his steam engine. Just 60 years elapsed before Stephenson's "Rocket" convinced the world of the feasibility of transportation by steam-power.

The locomotive shown in the lower figure competed in the famous tests of 1829 against the "Rocket" and the "Sans Pareil." It excited much interest, attaining a speed of almost 32 miles per hour when running light, but owing to breakdowns was unable to fulfill the required tests and was therefore withdrawn from the competition. It was afterwards used commercially.

The *Sans-pareil* was considerably over the maximum weight and according to a strict interpretation of the stipulations, should not have been allowed to contest; but although this question of over-weight was waived by the judges, and the engine given a fair trial, it showed such a capacity for consuming fuel without any corresponding ability to perform work, that it was decided inferior to the *Novelty* and the *Rocket*. The *Perseverance* was clearly outclassed by all the other competing engines, as its maximum speed was only five or six miles an hour.

133

The most consistent performer, and the final prize-winner, as everyone knows, was Stephenson's *Rocket*, the direct ancestor of all modern locomotives. The boiler of this locomotive was horizontal, as in modern locomotives, cylindrical, and had flat ends. It was six feet in length and a little over three feet in diameter. The upper half of the boiler was used as a reservoir for steam, the lower half being filled with water and having copper pipes running through it. The fire-box, two feet wide and three feet high, was placed immediately behind the boiler. Just above this, and on each side, were the cylinders, two in number, acting obliquely downward on the two front wheels of the engine, the piston-rod connecting with the driver by a bar pinned to the outside of the wheel, as in modern American locomotives.

The engine with its load of water weighed a trifle over four tons—seemingly little more than a toy-locomotive, as compared with the modern monsters more than thirty times that weight. But for its size the little *Rocket* was a marvelous performer, even as judged by recent standards. On the first day of the contests over the two miles of trial tracks, it covered twelve miles in considerably less than an hour, shuttling back and forth over the road. The next day, as none of the other engines was in condition to exhibit, Stephenson offered to satisfy the curiosity of the great crowd that had gathered—a crowd that contained representatives from all over the world—by an unofficial trial of the *Rocket*. He coupled the little engine to a car, loaded on thirty-six passengers, and took them for a spin over the road at the rate of from twenty-six to thirty miles an hour.

134

The following day some of the competing locomotives were still unable to exhibit, and again the *Rocket* was given a semi-official trial. Hauling a car loaded with thirteen tons' weight, it ran back and forth over the two-mile road, covering thirty-five miles in one hour and forty-eight minutes including stoppages. The maximum velocity attained was about twenty-nine miles an hour. As this performance was duplicated on the day of the official trial, the *Rocket* was declared the winner, and awarded the prize.

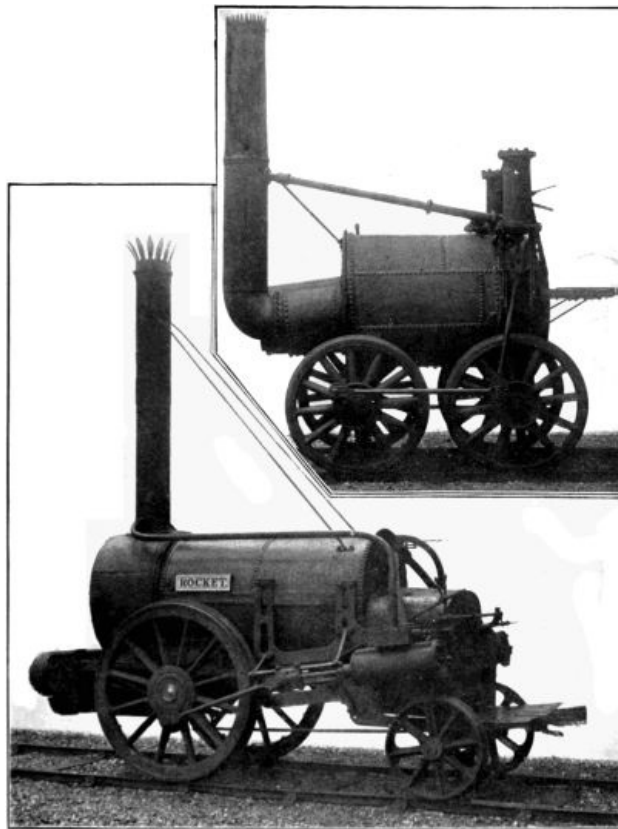

THE FAMOUS LOCOMOTIVES "ROCKET" AND "SANS PAREIL."

Stevenson's celebrated "Rocket" is known to everyone as the winner of the competition for the prize of 500 pounds offered in 1829 by the Directors of the Liverpool and Manchester Railway. The "Sans Pareil," which, like the "Rocket," is still preserved at the South Kensington Museum in London, competed unsuccessfully for the prize. Though not equal to the "Rocket" it was in many respects a well-made locomotive. It was purchased by the Liverpool and Manchester Railway Company and saw many years of active service.

Naturally there were many minor defects in the construction of this first locomotive, although most of them were too trivial and unimportant to affect the excellence of the machine as a whole. But it had one serious defect: the inclination of the cylinders caused the entire machine to rise and fall on its springs at every double stroke, producing great unsteadiness when running at any considerable speed. This was corrected a few months later by the suggestion of Timothy Hackworth, who drew plans for a locomotive having horizontal cylinders to be used on the Stockton & Darlington Railway. His plans were submitted to Stephenson, who constructed an engine from them called the *Globe*, which differed from the *Rocket* in having the cylinders not only horizontal, but placed on the inside of the wheels. A little later Stephenson built the *Planet* on much the same lines as the *Globe*, and this engine became the model for engine builders the world over. It is an interesting fact that American engineers adopted, and still cling to, Stephenson's original plan of having the cylinders act on rods attached to the outside of the wheels as in the *Rocket*, while English engineers have always built their locomotives with the cylinders on the inside, as arranged on the *Planet*.

135

Since the time of the *Planet* the general shape and arrangement of most locomotives has remained unchanged. In America the inclemencies of the climate compelled the invention of the cab; and it was here also that the bell, whistle, pilot, and sand-box were first introduced. But by 1850 the present type of locomotive had been produced; and although constant modifications are being introduced, the general appearance of the locomotive remains the same, the difference being mostly in the bulk.

IMPROVEMENTS IN LOCOMOTIVES IN RECENT YEARS

During the closing years of the nineteenth century the general improvements in the rolling-stock of railroads, and the constantly increasing demand for faster passenger service, stimulated manufacturers to attempt numerous improvements as well as many changes in the size of the more recent types of locomotives. In a general way these changes may be summarized as follows: A great increase in the size and weight, with increased speed and tractive power; the use of larger boilers with thicker shells; the substitution of steel for cast-iron in certain parts of the locomotive, thereby greatly increasing the strength; and finally, the economizing of steam by compounding.

136

There is no way of determining the exact amount of increase in the weight of engines during

the last decade, but the figures of some of the great manufacturing establishments will give a fair idea of this increase in a general way. In one of these establishments the average weight of a locomotive turned out ten years ago was 92,000 pounds for the engine alone, without the tender. At the present time the engines being manufactured by the same firm average 129,000 pounds, an increase of 37,000 pounds, or something over forty per cent. This average weight, however, gives but an inadequate conception of the size of the largest locomotives now being manufactured. The "hundred-ton" engine has become a commonplace. In 1909 a locomotive weighing, with its tenders, 300 tons was manufactured for passenger traffic on the Santa Fé lines.

In America there seems to be no limit to the sizes that may be reached; or at least up to the present time this limit has not been attained. In England and several of the Continental countries a great difficulty has been found to exist in the unlimited size of locomotives, in the fact that the bridges and tunnels of these railroads are, almost without exception, so low that any very great vertical increase in the size of the engine is out of the question without reconstructing many miles of bridges and tunnels at an enormous cost.

The increased demand for greater speed has also caused a marked increase in the amount of steam pressure per square inch in the boilers. In 1870 the average was about 130 pounds; by 1890 this had been increased to about 160 pounds; while at the present time steam is used frequently at a pressure of 225 pounds. Naturally this increase in pressure compels the use of heavier steel boiler plates. In 1890 the usual thickness of the steel sheets was one-half inch; but at the present time it is no unusual thing to use plates seven-eighths of an inch in thickness.

But probably the most important improvement in locomotive construction in recent years is the introduction of the compounding principle in the use of steam—a system whereby practically the entire energy of the steam is utilized, instead of a considerable portion of it being a dead loss, as in the older type of engine. As every one knows, the passage of the steam through a single cylinder of an engine does not exhaust its entire energy. In the compounding system this exhausted steam is made to pass through one or more cylinders after coming from the first, the energy of all these cylinders being utilized for the production of power.

The application of this principle of compounding is not new even in the field of locomotive construction. As early as 1846 patents for a compound locomotive were taken out in the United States, and such an engine built in 1867; but it is only since 1890 that compound locomotives have become popular in this country. In these compound locomotives the two cylinders are of unequal diameter, so proportioned "that the steam at high pressure in the smaller cylinder exerts upon the piston approximately the same force that is exerted by steam at a lower pressure in the larger cylinder. Steam is admitted first into the smaller cylinder, where it expends a portion of its initial energy, and then passes into the larger cylinder, where it performs an equal amount of work by exerting a diminished pressure upon a larger surface. This is the principle of compounding, the relative sizes and positions of the cylinders being varied according to the conditions to be met by the engine, or the ideas of the designer or builder, or of the purchaser. While in the marine and stationary engine the compound principle has been carried with success and economy to three and four stages of expansion in the use of steam, it has not been found practicable to go beyond two stages in compound locomotives."

In a pamphlet issued recently by one of the leading locomotive works of the country, some points of interest concerning the compound locomotive were stated concisely as follows:

"In stationary-engine practice the chief measure of the boiler efficiency is the economical consumption of coal. In most stationary engines the boilers are fired independently, and the draft is formed from causes entirely separate and beyond the control of the escape of steam from the cylinders. Hence any economy shown by the boilers must of necessity be separate and distinct from that which may be effected by the engine itself. In a locomotive, however, the amount of work depends entirely upon the weight on the driving wheels, the cylinder dimensions being proportioned to this weight, and, whether the locomotive is compound or single expansion, no larger boiler can be provided, after allowing for the wheels, frame and mechanism, than the total limit of weight permits. The heating surface and grate areas in both compound and single-expansion locomotives of the same class are practically the same, and the evaporative efficiency of both locomotives is chiefly determined by the action of the exhaust, which must be of sufficient intensity in both cases to generate the amount of steam necessary for utilizing to the best advantage the weight on the driving wheels. This is a feature that does not appear in any stationary engine, so that the compound locomotive cannot be judged by stationary standards, and the only true comparison to be made is between locomotives of similar construction and weight, equipped in one case with compound and in the other with single-expansion cylinders.

"No locomotive, compound or single-expansion, will haul more than its adhesion will allow. The weight on driving wheels is the limiting factor in the problem which confronts the locomotive engineer. Power can, of course, be increased by building a larger engine and augmenting this weight but in the present construction of tracks and bridges the limit of driving wheel load has almost been reached. Hence in modern locomotive practice the goal before the designer and engineer is to obtain maximum efficiency for the minimum weight admissible.

"It is not claimed for compound locomotives that a heavier train can be hauled at a given speed than with a single-expansion locomotive of similar weight and class; but the compound will, at very slow speed, on heavy grades, keep a train moving where a single-expansion will slip and stall. This is due to the pressure on the crank-pins of the compound being more uniform throughout the stroke than in the case of the single-expansion locomotive, and also to the fact

that, when needed, live steam can be admitted to the low-pressure cylinders."

Of course, the principal reason for compounding the locomotive is to economize steam, and this is unquestionably accomplished; but nevertheless the comparative economy of compound and single-expansion locomotives was for some time a mooted question. Numerous tests have been made with these two classes of engines, and the widest ranges of differences were shown in many instances. In some cases the compounds seem to show a saving of some forty per cent. in fuel; but this is by no means a determinative factor in the daily use of an engine. It is found that repairs on the compound are more difficult to make, and consequently more expensive than on the single-expansion engines; but on the whole it is very generally conceded that the compound saves its owners from ten to twenty-five per cent. over the older type.

The rapid increase of the size, and consequent coal-consuming capacity, of the modern locomotive has added another problem to engineering—that of keeping the yawning maw of the fire-box supplied with coal. There is a limit to the amount of work that the fireman can do, and the great engines in use at present tax even the strongest fireman to the utmost. If the size or speed of locomotives is increased very materially in the future it will be necessary to have two men, instead of one, as firemen, or to use mechanical stokers, or to find some other kind of fuel. In point of fact the mechanical stoker has been recently tried with success, and this will probably help in solving the problem. But there is also the strong probability that the use of liquid fuel will become more and more popular. At the present time many locomotives in the West and Southwest, as well as in Europe and in Asia, have been equipped with burners for the consumption of crude petroleum. No modification in the construction of the locomotive is required for this change of fuel except some slight alteration in the arrangement of the brickwork of the fire-box, and the introduction of the burners. These, however, are simple arrangements that throw into the fire-box, a spray of steam and vaporized oil, which burns freely and generates an intense and steady heat. With this kind of fuel the fireman need not be considered, as the largest engine thus equipped may be "fired" with far less labor than is required on the smallest coal-burning, narrow-gauge locomotive.

141

THE WESTINGHOUSE AIR BRAKE

The application of steam as a motive power for running trains of cars solved one great problem; but it created another. The second one was the problem of how to stop the trains once they had started. On short trains made up of the light cars used at first, the hand brakes were sufficiently effective for practical purposes. But as trains were increased in length and weight and were run at high speeds, it became imperative to find some means of stopping such trains quickly and with certainty.

142

With a hand brake working on each pair of trucks, as on passenger coaches, it was possible to make reasonably quick stops when there were enough members of the train crew to work all the brakes simultaneously. But in practice it was found impossible to maintain this ideal condition. For emergency stops the brakemen were summoned by signals of the whistle given by the engineer, and there was necessarily some little interval of time after this signal before the most alert crew could begin the relatively slow process of applying the brakes.

The engineer himself could give valuable aid in stopping the train by reversing his engine, the locomotive acting as a brake to check the oncoming cars. But this check acted only at the forward part of the train, and being applied suddenly, caused the rear cars to rush against the forward cars with terrific force, sometimes driving in the bumpers and wrecking the train. Obviously an ideal system of brakes must be one that acted upon all the cars of the train simultaneously and under control of the engineer; and presently such a system was invented by Mr. George Westinghouse.

Other inventors had tried to produce a practical system of brakes, such as those using steam as a working force, or systems of hand-wound springs; but Mr. Westinghouse utilized compressed air, and from the first his brakes proved effective.

143

His first air brake, operated successfully in 1869, was the "straight air brake" type—one that has now been replaced almost universally by the automatic. In this brake system there was an air reservoir on the locomotive, and steam was used for making the compression. From this reservoir a line of gas pipe ran through the cab of the engine beneath the tender and under each car, the space between the cars being bridged by rubber tubes and easily-adjusted couplings. This line of pipe, called the train pipe, was connected near the centre of each car with a cylinder which contained a piston with a stem which acted upon the brake shoes by means of a series of levers and connecting rods.

In the cab, placed conveniently for the engineer, was a valve by means of which he could cause the compressed air to flow into the train pipe and thus act upon the brake cylinders of the cars. This could be done gradually for making a slow stop, or with full force as the case required, and the brakes could be released by turning the valve to a point which opened a vent and allowed the air to escape.

The effect of this invention was revolutionary. Stopping the train was no longer dependent upon manual labor applied intermittently at different points, but was placed entirely in the hands of the engineer who applied the required power almost simultaneously at all points along his line of cars. Thus the brakeman was relieved of one of his perilous tasks, which on freight trains took a heavy toll in loss of lives.

144

This relatively simple, and usually effective, system had two grave defects. The first of these lay in the fact that if there was a leak—even a very small one—anywhere along the line of the train pipe or the brake cylinders, the brakes would not work, the compressed air being exhausted into the atmosphere instead of acting on the brake cylinders. The common accident of having his train "break in two" rendered the engineer powerless to stop the cars, and disastrous "runaways" sometimes resulted. The second defect, which became more and more apparent as the length of trains was increased, was the impossibility of applying the air to the brakes of the rear cars as quickly as to those near the engine, since the compressed air could not travel the length of the train pipe instantaneously, on account of the frictional resistance.

These defects were quickly recognized by Mr. Westinghouse, and in 1876, seven years after he applied his first invention, he produced his automatic air brake which overcame them effectually. In this brake the train pipe and the air reservoir were retained as in the straight air brake system, but in addition each car was equipped with a storage reservoir of sufficient size to supply the brake cylinder. In place of the older arrangement in which the train pipe simply retained air at atmospheric pressure when not in use, the new system kept the air in the train pipe under a considerable pressure at all times when the brake was not in use. And, reversing the conditions of the straight air brake, the engineer in order to apply the brakes let out the air in the train pipe instead of forcing air into it, a "triple valve" on each car performing the work of operating the brake cylinder automatically. 145

The advantage of this system over the older one is obvious. Whereas the detachment of a portion of the train, or a leak in any part of the air brake system heretofore had left the engineer helpless, exactly the reverse condition was produced in the new system. Any leakage of air, either from a break or a defect, caused every brake on the entire train to be applied to the wheels and brought the train to a stop. Moreover, with the new system it was now possible to equip each car with a valve which would lessen the pressure of air in the train pipe so that the train could be brought to a stop by the trainmen in the rear or intermediate coaches as readily as by the engineer.

This system worked perfectly on passenger trains; but on long freight trains the resistance to the passage of the escaping air through the train tube was so great that if an emergency required the full force of the brake to be applied suddenly, the brakes of the rear cars did not come into use until several seconds after those of the forward cars. The result was that the momentum of the rear cars caused them to strike the forward cars with great violence. But Mr. Westinghouse overcame this defect by an ingenious use of the triple valve mechanism of each car, whereby the application of the emergency brake by the engineer caused the air in the train pipe on each car to be discharged simultaneously into the brake cylinder. In this manner the discharge of air not only allowed the brakes to act, but assisted them in doing so. This was only the case, however, when the emergency application of the brake was made, this system of venting on each car into the brake cylinder not being brought into play when ordinary stops were made. Thus the engineer in this quick-action automatic air brake has really two brakes at his command, one for making ordinary stops, the other for emergencies. 146

In 1891 a so-called high-speed air brake was perfected, this brake being really a modified quick-action automatic brake. This modification consists of the addition of an automatic pressure-reducing valve connected with each brake cylinder. In the high-speed air brake as applied when the train is running rapidly, the highest possible pressure is applied at once to the wheels, but this pressure is lessened by the automatic pressure-reducing valves as the speed diminishes. This method of applying the brakes is the most effective way of getting the full benefit of their stopping power. This high-speed brake, therefore, represents the highest perfection in train-stopping devices.

We have referred here specifically to the air brake as used on steam railroads. In another chapter the subject has been touched upon in connection with electric railroads. In such brakes the compression of the air is accomplished by electricity instead of steam, but the general principles involved are the same as those just described.

It should not be understood that the Westinghouse air brake was the only one, or the only type of brake, devised and brought to practical perfection. For a time a vacuum brake, which utilized atmospheric pressure, offered keen rivalry. But eventually the type of brake perfected by Mr. Westinghouse, modified in certain details in the various countries of Europe and America, gained precedence, which it still retains. 147

AUTOMATIC COUPLINGS

The perfection of the air brake removed one great source of danger that menaced the crews of freight trains. There still remained another almost as great, particularly in the matter of maiming its victims, when not actually killing them. This was the old method of coupling freight cars as practiced in America. There were few old-time trainmen, indeed, who could show a complete set of full length digits, the buffers of the old-fashioned couplings being responsible for the lost and shortened members.

The freight brakeman has to make scores of couplings on every trip. And he literally took his life in his hands upon each and every occasion of making a coupling by the old method.

This old form of couplings consisted of two buffers—one on each car—joined together by an iron link about fifteen inches long, a movable pin inserted at either end holding the link in place

and thus joining the cars. When a coupling was to be made the brakeman raised the pin in the buffer of the stationary car and tilted it at an angle in the pin-hole at the top of the buffer so that, while it remained raised, the jar of the striking buffers at the moment of coupling caused it to fall into place and complete the coupling. The link was left hanging in the moving car which was being shunted in to be coupled; but in this position the projecting end was so low that it would miss the hole in the opposite buffer, and thus fail to make the coupling, unless raised and inserted just at the moment before the buffers came together.

This raising and inserting of the link was the dangerous part of making a coupling. It could only be done by the brakeman while standing between the cars. And he must raise the link, insert it, and remove his hand in a fraction of a second if the car was moving at a fair rate of speed, otherwise his fingers or hand would be caught between the buffers and crushed. And a crushed hand or arm meant subsequent amputation, for the force of the collision between the buffers crushed the bones beyond repair.

There was a way in which the coupling could be made whereby the hand was not endangered. This was by using a stick for raising and guiding the link into the buffer. Some railroads at first furnished sticks for this purpose. But no brakeman would stoop to use them. Had he done so he would have been hooted and jeered off the road by his train mates. And so his pride made him risk his limbs and his life, and fostered the recklessness of the old-time brakeman.

But in 1879 Mr. Eli Janney, of Pittsburg, patented an automatic car-coupler that was both simple and effective; and in 1887 the Master Car Builders' Association accepted this type of coupler. A little later the U. S. Government, influenced by the appalling loss of life among the brakemen, passed laws compelling all cars to be equipped with some form of automatic coupling device, and naturally the Janney coupling was the one adopted. In using this coupling the brakeman did not have to step into the dangerous position between the cars, either for making the coupling, or disconnecting the car. The act of coupling was done automatically, while the uncoupling was effected by the use of a lever operated from the side of the car.

A somewhat technical description of this coupling is as follows:

"The Janney coupling consists of a steel jaw fitted on one side with a knuckle or L-shaped lever turning on a vertical pin; this knuckle when being swung inward lifts a locking pin which subsequently drops and so prevents the return of the knuckle. An identical coupler is fitted to the end of the adjacent vehicle, and, so long as both or either of the knuckles are open when the vehicles come into contact, coupling will be effected; to uncouple, it is only necessary to raise either of the locking pins, by means of a chain or lever at the side of the vehicle. The knuckles have each a hole in them to permit of the use of the old link and pin coupler, when such a fitting is met with. At first, this coupling gave some trouble through the locking pins occasionally creeping upward, but in the larger model, which represents the later form, there is an automatic locking pawl that prevents this motion; owing, however, to the pawl being attached to the lifting shackle, it in no way interferes with the pin being raised when disconnecting."

Even before the invention of the Janney coupling a semi-automatic coupling device had been used extensively on passenger cars. But this device which in effect was that of two crooked fingers hooked together, allowed the ends of the coaches to swing and roll in a manner most disagreeable to many passengers. The Janney couplings corrected this, since these couplings in their improved form hold the ends of the cars as in a vice.

A COMPARISON—THE OLD AND THE NEW

Stephenson's locomotive and its tender, when loaded to full capacity with fuel and water, weighed seven and three-quarter tons. The locomotive itself was a trifle over seven feet long. In 1909 the Southern Pacific Railway purchased a Mallet Compound locomotive which, with its tender, weighs three hundred tons, or approximately forty times the weight of the little *Rocket*. This great locomotive is over sixty-seven feet long, or some nine times the length of the *Rocket*, and will haul more than twelve hundred tons back of the tender.

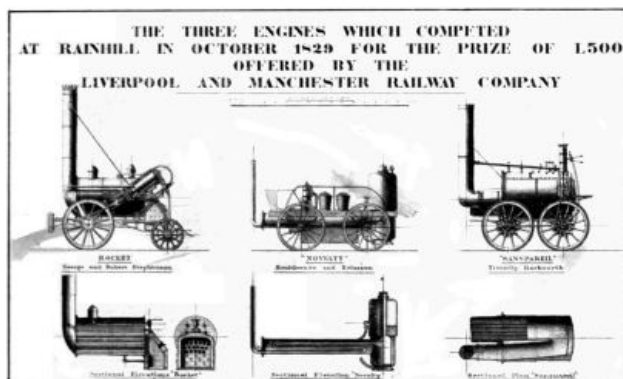

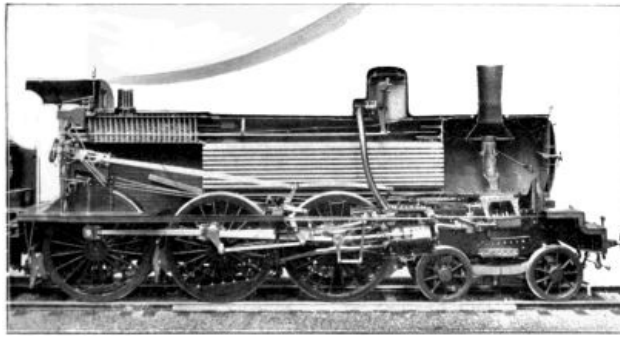

THE DEVELOPMENT OF THE LOCOMOTIVE.

The lower figure represents a longitudinal section of a modern French locomotive, for comparison with the sections of the famous engines of 1829. The weight of the "Rocket," with its four-wheel tender which carried 264 gallons of water and 450 pounds of coke was 4-1/4 tons. The French locomotive with its tender in working order, carrying 3300 gallons of water and five tons of coal, weighs 99 tons, and the length of the engine and tender is 56.3 feet.

The cylinders of the *Rocket* were eight inches in diameter, with a seventeen inch stroke; the high-pressure cylinders of this Mallet locomotive are twenty-six inches in diameter, and the low-pressure cylinders are forty inches. But curiously enough the driving wheels of the two engines show little discrepancy, those of the *Rocket* being fifty-six inches in diameter, as against fifty-seven for those of the larger engine. The total heating surface of the *Rocket* was one hundred and thirty-eight square feet, that of the new locomotive 6,393 square feet. To heat this great surface oil is used for fuel, so that the task for the fireman is lighter than on many locomotives less than one-half the size.

151

On this locomotive there are two sets of cylinders driving two sets of driving wheels on each side, making a total of sixteen drivers in all. From the size of these drivers it is evident that the engine is designed for strength rather than speed, although of course relatively high speed can be attained if desired. On the section of road over which it operates there is a maximum grade of one hundred and sixteen feet per mile, and it was for negotiating such grades with full loads that the locomotive was designed.

152

FROM CART TO AUTOMOBILE

THE use of the wheel as a means of reducing friction dates from prehistoric times. The introduction of this device must have marked a veritable revolution in transportation, but unfortunately we have no means of knowing in what age or country the innovation was effected. We only know that the Chinese have used wheelbarrows and carts from time immemorial, and that sundry very ancient pictures and sculptures of the Egyptians and Babylonians prove that these peoples were entirely familiar with wheeled vehicles.

The earliest form of wheel was doubtless a solid disk, and such a wheel is still in use in many places in the East; but the wheels of the Assyrian chariot were spoked after the modern fashion, and provided with rims of metal. The introduction of the wagon spring, however, was a comparatively modern innovation. The use of springs very considerably reduces the resistance, thus adding to the efficiency of wheeled vehicles; but the reduction is not very obvious unless the roads are tolerably good, nor is it probable that the ancient nations could readily have measured the effect even had the idea of springs suggested itself.

As regards good roads, these are, to be sure, no modern invention, since the Romans had carried the art of road-building to a very high degree of perfection. The integrity of the Roman Empire depended very largely upon the highways that linked all parts of its circumference with the Imperial centre; and in a perfectly literal sense all its roads led to Rome. The Roman roadbed was constructed of several layers of stone, and it was one of the most resistant and permanent structures ever devised. As late as the sixteenth century of our era there were no roads worthy of the name in England except the remains of those constructed many centuries before by the Roman occupants. It was not until well toward the close of the eighteenth century that Macadam and Telford devised methods of road-making whereby broken stone and gravel, pounded to form a smooth surface, gave the modern world roadbeds that were in any way comparable to those early ones of the Romans.

This development of road-building corresponded, naturally enough, with an advance in the art of carriage building, and the increased popularity of stage coaches. We are told that about 1650 the average rate of speed of the stage wagons in England was only four miles an hour; whereas the stage coaches moved over the improved roadbeds of the nineteenth century at an average speed of about eight miles an hour, which was sometimes increased to eleven miles. After about the year 1836, however, the stage coach was rapidly displaced by the steam railway, and the interest in roadbeds somewhat abated until brought again prominently to public attention by the users of bicycles and automobiles.

153

154

THE DEVELOPMENT OF THE BICYCLE

It is rather surprising to learn that in point of time the automobile antedates the bicycle. Yet such, as we shall see in a moment, is the fact. Every one is aware, however, that the bicycle came into popularity at a time when the very existence of the automobile had been practically forgotten, and that subsequently it lost its popularity almost overnight when the automobile came to its own. Viewing the subject retrospectively, perhaps the most singular thing is that both vehicles were so long delayed in making their way to public favor. There were, however, sundry very practical obstacles placed in the way of the larger vehicle; and the bicycle was not at first a device calculated to prove attractive to the average wayfarer.

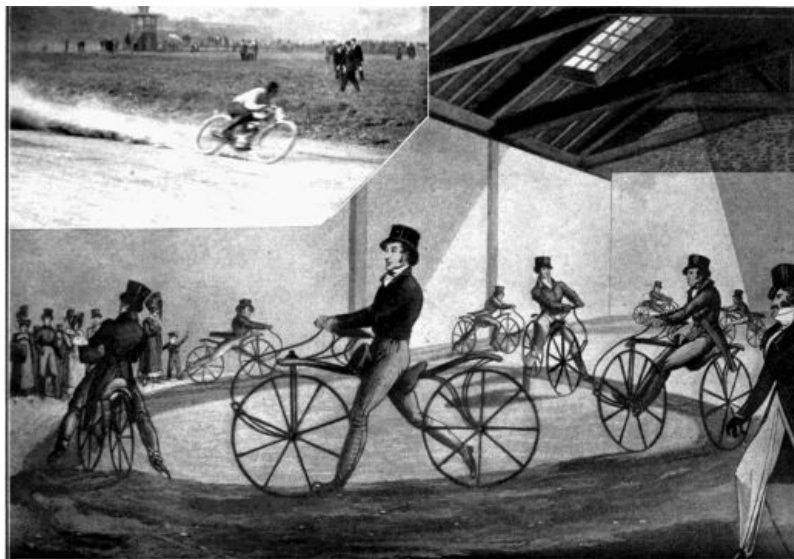

THE HOBBY-HORSE OF 1820 CONTRASTED WITH THE MOTOR CYCLE OF

For a brief period about 1820 the hobby horse was very popular with English dandies. Our illustration reproduces a contemporary print. The (1909) motor cycle shown in the small picture is compassing a mile in 40 seconds.

The very earliest bicycle appears to have been the so-called hobby horse or dandy horse introduced about the year 1818 by Baron von Drais in France. It was a primitive vehicle, the user of which half rode and half ran, propulsion being effected simply by thrusting the feet against the ground. In effect the rider of the hobby horse ran with a stride greatly lengthened through the partial support afforded by the saddle, and with correspondingly increased speed. He could, of course, on occasion coast down hill or on a level surface when considerable momentum had been acquired, and supports for his feet were provided to facilitate this end. At first the machine promised to become popular, but it was soon ridiculed out of court.

155

Something like twenty years later—that is to say about the year 1840—a treadle-bicycle was invented by Kirkpatrick MacMillan, an English blacksmith. The machine did not become popular, however, and it was not until simple cranks were fitted to the front wheel of the bicycle that this form of vehicle came into anything like general use. This very simple expedient was first suggested, seemingly, by Pierre Lallament, a Frenchman, in 1866. His machine came to be known in England as the bone shaker, and doubtless it deserved its name, for as yet neither the wire suspension wheel nor the rubber tire had been invented. Both these improvements were quickly introduced, however; the suspension wheel by Mr. E. A. Cowper, in 1868. The first rubber tires, used about 1870, were solid, and it was not until 1888 that the Irishman, Mr. J. B. Dunlap, introduced the pneumatic tire. Meantime the geared bicycle, with which every one is nowadays familiar, had been introduced in 1879 by Mr. H. J. Lawson and brought to the familiar form of the "safety" in 1885 by Mr. Starley. The combination of low wheels geared to any desired speed with pneumatic tires was the finishing stroke.

The problem of making the bicycle a relatively speedy vehicle had indeed been solved by the use of a large wheel—sometimes sixty inches in diameter—operated by a simple crank after the manner of the early machine of Lallament; but while bicycles of this type attained a considerable measure of popularity, the danger of taking a "header" on encountering any obstacle in the road was one that seemed to the average person to out-measure the pleasure or benefit to be derived from rapid transit thus attained. The safety bicycle, however, practically eliminated this danger. It was, moreover, comparatively easy to balance; and not long after its introduction in perfected form, with pneumatic tires, it had made an appeal to which all the world responded. For a few years the safety bicycle was the most conspicuous of vehicles on every country road, and partisans of outdoor life believed that the health and stamina of the generation were to be increased immensely by the new vehicle.

156

Nor were these anticipations altogether visionary, as undoubtedly the bicycle did do much to improve the average health of nearly all classes of citizens. But its popularity was too suddenly acquired to be permanent, and at the very moment when it was most used, another vehicle was suddenly developed which was to lead to its practical abandonment by the great mass of people for whom it might have been supposed to afford a means of permanent recreation.

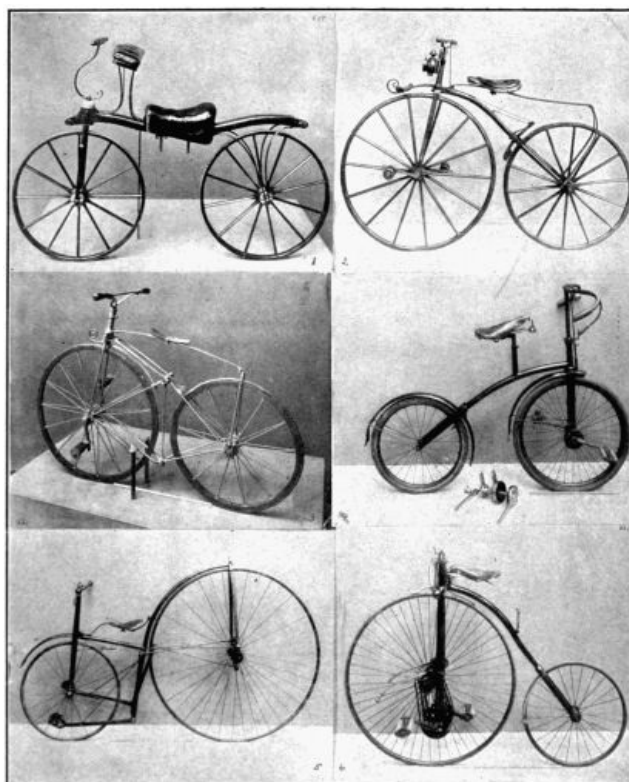

THE EVOLUTION OF THE BICYCLE.

Fig. 1.—The hobby horse or dandy horse, the forerunner of the bicycle, which was patented in France in 1818 by Charles, Baron von Drais. Fig. 2.—The so-called "Bone Shaker" invented about 1865 by Pierre Lallement. Fig. 3.—"Phantom" bicycle introduced in England about 1869, its most important improvement consisting of wire spokes in place of rigid spokes. Fig. 4.—"Bantam" bicycle introduced in 1893. Its peculiarity is an epicyclic gearing through which the wheel is made to revolve more rapidly than the cranks. Fig. 5.—An early safety bicycle introduced in 1876. The crank and lever driving apparatus is similar to that of a machine made by Kirkpatrick MacMillan in 1839. Fig. 6.—"Kangaroo" bicycle patented in England by W. Hillman in 1884. The peculiarity consists in the use of a chain gearing to increase the speed of the wheel. The principle is precisely that of the modern bicycle, though the application of the chain to the front wheel made a cumbersome apparatus.

THE COMING OF THE AUTOMOBILE

The vehicle that effected this sudden eclipse of the bicycle is, as everyone knows, that form of power-driven carriage known in England as the motor car, and in France and America as the automobile. The first form of this vehicle to gain popularity was a tricycle driven by a small steam motor. But almost immediately the recently devised gas engine was called into requisition, and after that the development of the automobile was only a matter of detail. But, as so often happens with practical inventions, there are disputed questions of priority regarding the application of the gasoline engine to this particular use. The engine itself was perfected, as we have elsewhere seen, about 1876, by the German, Dr. Otto.

157

It appears that in 1879 an American, Mr. George B. Selden, applied for a patent designed to cover the use of the internal combustion engine as a motor for road vehicles. Owing to technical complications the patent was not actually issued until the year 1895. Meantime at least as early as 1885 Herr Daimler in Germany had used the gasoline motor for the practical propulsion of a tricycle; and not long after that date the right to use his patents had been acquired in France by Messrs. Panhard and Levassor. These men soon applied the Daimler motor to four-wheeled vehicles of various types, and almost at a bound the automobile as we know it was developed. Early in the '90's the custom of having annual road races was introduced, and before the century had closed the automobile was everywhere a familiar object on the roads of Europe and America.

While the introduction of the automobile is thus a comparatively recent event, it should be known that the idea of using mechanical power to propel a road vehicle is by no means peculiar to our generation. Practical working automobiles were constructed long before any person now living was born. The very first person to construct such a vehicle was probably the Frenchman, Cugnot, who manufactured a steam-driven wagon, using the old Newcomen type of engine, in the very year—by a curious coincidence—in which James Watt took out his first patent for a perfected steam engine; that is to say, in the year 1769.

158

Cugnot's automobile was a heavy four-wheeled affair intended for military service. It actually progressed along the road at the rate of three or four miles an hour. But the problem of carrying fuel and water had not been solved, and either for that reason or because the authorities in charge lacked imagination and did not regard the device as offering advantages over traction by horses, nothing came of Cugnot's effort except the scientific demonstration that the idea of a self-propelled vehicle was not merely the dream of a visionary. A second automobile truck of similar design, made by Cugnot a year or two later, may be seen to this day in the Museum of Arts and Measures in Paris.

A few years later—namely in 1785—an Englishman, William Murdoch by name, whose interest in steam engines is evidenced by the fact that he was in the employ of Bolton and Watt, manufactured a small tricycle driven by a Watt engine. This vehicle, running under its own power, developed a good degree of speed; and had not Murdoch's employers forbidden him to continue his experiments, the practical automobile might perhaps have gained popularity an entire century earlier than it did.

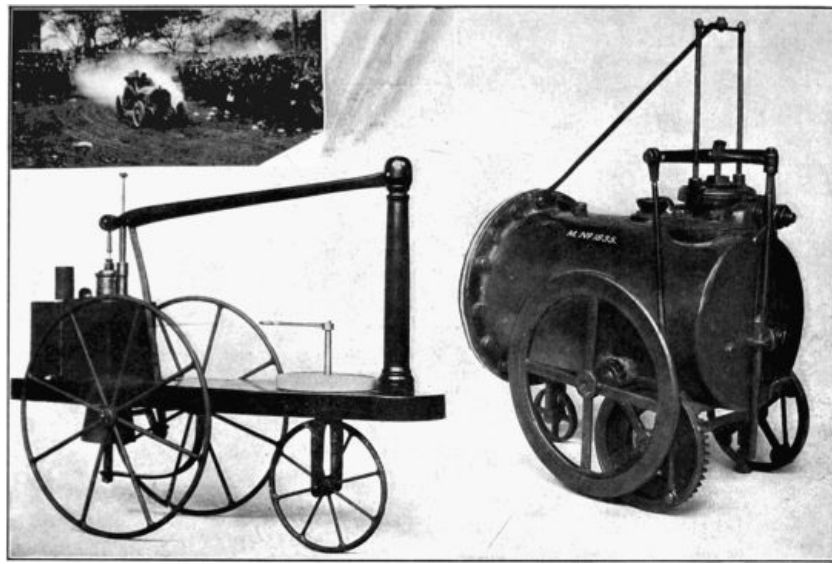

THE EXTREMES OF AUTOMOBILE DEVELOPMENT.

At the left, William Murdock's automobile of about the year 1781. Murdock made several experimental models which worked successfully, but strangely enough Bolton and Watt, his employers, discouraged his efforts and induced him ultimately to abandon the invention, which nevertheless had demonstrated the possibility of propelling a vehicle by steam power. At the right, the original model of Richard Trevethick's road locomotive, constructed in 1797. The success of this model led Trevethick to construct a steam carriage which was successfully tried on the roads in England in 1801. The small picture in the upper corner shows the modern craft that is the outgrowth of these crude vehicles—the winning automobile in the Vanderbilt race on Long Island in 1909.

As the case stands, however, the automobile of Murdoch failed as signally as had that of Cugnot to gain general recognition. But it is quite possible that a knowledge of the device had come to the attention of another Englishman, Richard Trevithick by name, who was at once a practical experimenter of great skill and a man of fertile imagination. Trevithick, himself the inventor of a high-pressure steam engine, adjusted his engine to a large road vehicle, and in the year 1804 exhibited this automobile on the roads of Cornwall, and subsequently in London, where it would probably have made its way had not the inventor been an extremely erratic genius, who presently shut up his coach and turned his attention to another form of vehicle. This, it will be observed, was full twenty-five years before that memorable date on which Stephenson launched his famous *Rocket*. Nothing came of Trevithick's experiment at the moment, beyond the demonstration of a principle—which indeed was much; but it was not long before various other inventors took up the idea, and as early as 1824 a number of automobiles, some of them weighing as much as three or four tons, were in successful operation on the highways of England. Some of these even gave regular passenger service, and attained the unprecedented speed of twelve or fourteen miles an hour. All this, it will be observed, was before the first locomotive running on rails had attracted any attention. Stephenson had indeed begun his experiments, but up to this time they had been confined exclusively to tramways in connection with collieries.

159

In the year 1829 Stephenson made his famous demonstrations with the *Rocket*, a locomotive running on rails, which attained a speed of thirty miles an hour, contrary to all the predictions of the wiseacres, who had declared the inventor a lunatic for hoping to attain even ten miles. We have already noted that the railway on which the test was made was not built with the expectation of utilizing steam power, that being regarded as a dreamer's vision. Lord Darlington prevented the construction of the road for a time because it chanced to run near his fox covers; and legislative permission was finally secured only with the proviso that the railway was to avoid the region of the preserves. Stephenson with difficulty secured permission to make an experiment on the railway with his engine, in competition with other would-be inventors; and it was his unexpected success that turned the scale in favor of steam power. But even the startling success of the *Rocket* did not make a great impression upon the British public, the incident being given but slight notice in the periodicals of the day, and no mention being made of it in the *Annual Register*.

160

All this is of interest as showing the attitude of a conservative public toward the steam locomotive running on a railway, and as partially explaining the antagonism to self-propelled road vehicles which found, most unfortunately, an exponent in no less a personage than the Duke of Wellington, then prime minister. The opinion and attitude of the duke were made evident in 1829, in connection with a steam automobile invented by a Mr. Gurney, which was capable of running on an ordinary road at a rate of at least ten miles an hour. The duke was old, and age had strengthened his inherent conservatism. He lent a ready ear to the claims—largely instigated, no doubt, by persons interested in horse traffic—that the automobile on an ordinary road was a menace to public safety, and no doubt his influence had a large share in helping on the unfavorable public opinion and the adverse legislation which were presently to block the

161

further progress of the motor car.

Doubtless also the amazing success of the railway locomotive tended to attract the attention of the public away from the automobile, and thus made possible the passage of restrictive laws. In any event, the motor car, notwithstanding its demonstrated possibilities, virtually passed from the scene at about the time when the railway locomotive made its spectacular entrance. That public interest in the matter did not subside immediately, however, is evidenced by the fact that such a book as Gordon's *Treatise on Elementary Locomotion by Means of Steam Carriages on Common Roads* passed through three editions between the years 1832 and 1836.

AN EXTRAORDINARY PIECE OF LEGISLATION

Indeed, notwithstanding legislative rebuffs, here and there an inventor kept up his experiments, and in 1861 the automobile had attained so much prominence as to be given parliamentary attention. Four years later, in 1865, an extraordinary law was passed which deserves to be remembered as one of the greatest monuments of legislative folly ever recorded in connection with an economic question. This law provided that, in the case of any locomotive moving on a public highway, the number of persons required to drive the engine should be increased to three, and that the vehicle should be preceded by a man with a red flag.

162

The latter provision suggests at first sight that the British legislator had here been moved to curiously un-British facetiousness; but there was really no such intent, as another provision of the law, limiting the maximum speed to four miles an hour, sufficiently testifies.

Other laws of similar tenor supported this one, and the validity of these decrees was finally sustained through an appeal to the Court of Queen's Bench, which brought forth the decision that the law applied to every type of self-propelled vehicle from the traction engine to the Bateman steam tricycle. Naturally this decision gave the quietus to automobile—or, to use the more English word, motor car—progress in Great Britain.



AN ENGLISH STEAM COACH OF 1827 AND A NEW YORK TAXICAB OF 1909.

The steam coach constructed in 1827 by Sir Goldsworthy Gurney was the prototype of several others which entered upon regular and successful service between various English cities, and which are said to have maintained an average speed of about 12 miles and a maximum speed of a little over 20 miles an hour. The above figure reproduced from a contemporary lithograph shows the carriage that operated between London and Bath. It weighed about 2 tons and carried six inside and 12 outside passengers.

It appears, then, that the idea of an automobile travelling on an ordinary highway preceded that of the locomotive railway. It was, indeed, by far the more natural idea of the two, since

tramways were at that time but little used outside of collieries. And it seems scarcely open to doubt that the repressive legislation was directly responsible for deflecting the progress of mechanical invention away from what seemed the more natural direction of development. It is always hazardous in such a case to attempt to guess what might-have-been under different circumstances; but considering the practical results already achieved as early as 1824, one can scarcely avoid the conviction that had legislation favored, instead of opposing, the inventor, the automobile might have been developed in Great Britain as rapidly as railway traffic; in which event the middle of the nineteenth century would have seen the world at least as near the horseless age as we are in reality at the close of the first decade of the twentieth century. What this would have meant in its economic bearings on civilization during the past fifty years, the least imaginative reader can in some measure picture for himself.

163

In opposition to this view it might be urged that the real progress of the automobile has taken place since 1885, when the Daimler oil engine was substituted for the steam engine in connection with motor vehicles. But in reply to this it must be remembered that the workable gas engine had been invented as early as 1860, and that the Otto engine, of which the Daimler is a modification, was patented as early as 1876. These developments, it will be noted, took place at just about the time when the new interest in the automobile had been aroused, as evidenced by the repressive British legislation just referred to. It can be but little in question that had the early interest in the British automobile been maintained, inventive genius would long since have provided a suitable motor. There was no incentive for the English inventor during those long years when the automobile was under legislative ban; and in the meantime the idea of the highway automobile seems not to have taken possession of other nations.

When that idea did make its way, it was very soon put into tangible operation, as everybody knows. And the fact that England made no progress whatever in this line until the repressive laws were repealed in 1896, whereas France, Germany, and America had leaped far ahead in the meantime, is in itself demonstrative. Moreover, as regards the question of a motor for the automobile, it should not be forgotten that the steam-engine is by no means obsolete. The victories of Mr. Ross' machine at Ormonde in 1905, and of the Stanley steamer in 1906 (a mile in 28-1/5 seconds), show that steam is distinctly a factor, notwithstanding the popularity of the gasoline engine. The steam motor might have served an admirable purpose until such time as a better power had been developed.

164

However, it is futile to dwell on might-have-beens. Let us rather consider for a moment the spectacular development of the automobile with particular reference to its striking capacities as an eliminator of space.

SCIENTIFIC ASPECTS OF AUTOMOBILE RACING

A mile in 34-1/5 seconds. That is the automobile record established at Ormonde Beach in January, 1905. The record mile was made by Mr. H. L. Bowden, of Boston, with a machine of peculiar construction. It consisted essentially of two four-cylinder motors adjusted to one machine, giving an engine of 120 horse-power. The machine weighed 2,650 pounds, exceeding thus by more than four hundred pounds the usually prescribed limits of weight. The record, therefore, stood as a performance in a class by itself. But that is something that interests only the specialist. For the general public it suffices that an automobile propelled by a gasoline engine covered a mile in 34-1/5 seconds, or at the rate of one hundred and five miles an hour.

165

This record was made on Wednesday, January 25, 1905. A little earlier on the same day the previous automobile record of a mile in thirty-nine seconds—made at Ormonde by Mr. William K. Vanderbilt, Jr., in 1904—had been twice broken; first by Mr. Louis Ross, who made the mile in his 40 horse-power steam auto of "freak" construction in thirty-eight seconds; and by Mr. Arthur McDonald, driving a 90 horse-power car belonging to Mr. S. F. Edge. Mr. McDonald's record was a mile in 34-2/5 seconds, and this stood for a time as the new record for cars of regulation weight.

It thus appears that Mr. Vanderbilt's record was reduced first by one second, then by 4-1/5 seconds, and finally by 4-2/5 seconds on the same day. Obviously the conditions were peculiarly favorable on that day, or else a very marked improvement in the construction of racing automobiles had taken place within a single year. The latter is doubtless the true explanation, since, according to all reports, the conditions at Ormonde Beach that year were not peculiarly favorable, but rather the reverse. The fact, too, that the five mile record was reduced to the low figure of three minutes seventeen seconds—this also by Mr. Arthur McDonald—on the day preceding that on which the mile record was so completely smashed, corroborates the idea of improved mechanism rather than improved conditions. In any event, the jump from 39 to 34-1/5 seconds is a notable one; as will be evident from a simple computation which shows that the record holders of 1905 would have run away from the champion of 1904 at the rate of no less than nineteen feet for each second of the mile.

166

Let us pass at once—omitting transition stages—from these records to the new mark set on March 16th, 1910, at Ormonde Beach by Mr. Barney Oldfield. Driving a Benz automobile of two hundred horse-power, he compassed the mile in 27.33 seconds. The new record has a peculiar interest, not merely because it is the fastest mile ever made by an automobile, but because it is in all probability the fastest mile ever travelled by a human being who lived to tell the tale. A few unfortunates, falling from balloons, or from mountain cliffs, may have passed through space at a

yet more appalling speed; but they lost consciousness, never to regain it, long before the mile was compassed. The automobile driver retains his senses throughout his breakneck mile—they are keenly on the alert indeed—and comes away unscathed to tell the story of what must be a truly thrilling experience.

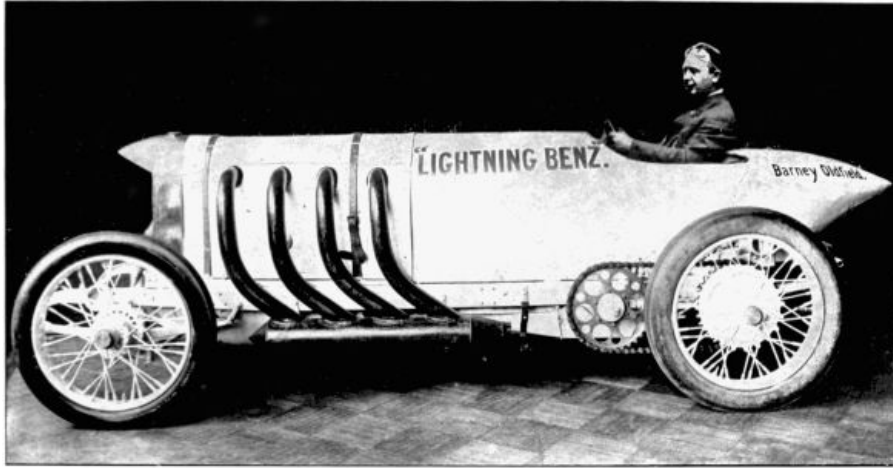

A RACING AUTOMOBILE.

In this 200-horse-power Benz car Barney Oldfield reduced the world's mile record to 27.33 seconds—a speed of 131.72 miles an hour—and the two-mile record to 55.87 seconds. The mile record was made at Ormonde Beach, Florida, March 16, 1910; the two-mile record at the same place a few days later.

Nor is it merely in contrast with other human experiences that the new performance takes on "record" proportions. It is at least doubtful whether any member of the animal kingdom ever passed through a mile of space at such a speed as that attained by Mr. Oldfield. The fastest quadruped on the globe is almost unquestionably the thoroughbred horse. But the fastest mile ever compassed by a horse—Salvator's straightway dash in 1:35-1/2—is a snail's pace in comparison with Mr. Oldfield's speed. Salvator covered a little over fifty-five feet per second; the racing motor covered a trifle over 193 feet—thus gaining 138 feet in each second.

167

The trotting horse at its best—a mile in 1:58-1/2—is of course much slower still; Lou Dillon's record mile being made at the rate of 44-1/2 feet per second. Dan Patch, the swiftest pacer, in his mile in 1:56 made just one foot per second more than the trotter. Both pacer and trotter, it should be added, made their records with the aid of a wind-shield, without which their best performances are some seconds slower.

If we make comparisons with different varieties of man-made records, we find that the swiftest human runner covers his mile at the rate of about twenty-one feet per second; the skater brings this up to about thirty-four feet; and the bicyclist attains the acme of muscle-motor speed with his eighty feet per second. In the case of the bicyclist, the wind-shield pace-maker on the auto-cycle plays an important part. But even so the cyclist would be left behind one hundred and thirteen feet each second by the flying automobile.

All these types of record maker, therefore, are quite outclassed. If we could not find any real competition for the automobile in the animate world, we must seek it in bird-land. Here, it might be supposed, the space devourer would find a match. But it is not quite certain that such is the case. The old-time books on natural history tell us, to be sure, of flight speeds that make the new records seem slow. They credited the European swift, for example, with two hundred and fifty miles an hour. But more recent observers, made cautious by the scientific spirit of our age, are disposed to discredit such estimates, which confessedly are little better than guesses.

168

The only officially timed bird flights are the flights of homing pigeons; and here the record credits the homing bird with only one hundred miles an hour. This means 124 feet a second, as against the motor's 193. According to these figures, the automobile could give the pigeon a start of almost two thousand feet and yet sweep forward and overtake it in its flight, before it passed the mile-post. Perhaps the comparison is not quite fair, since no doubt the pigeon may perform some individual miles of its journey at more than the average speed; but it may well be doubted whether its maximum ever reaches the mile-rate of 27.33 seconds.

It is within the possibilities, however, that some other birds have even surpassed this speed. The falcon, for example, is probably a swifter bird than the pigeon, at least for short distances. Some one indeed has credited the hawks with a speed of one hundred and fifty miles an hour. But this, I feel sure, is a great exaggeration. I once saw a hen harrier pursue a prairie-chicken, without seeming to gain appreciably for a long distance; yet the prairie-chicken is by no means among the speediest of birds. Many of our ducks, for example, quite outclass it; indeed I should be disposed to admit that the teal or the canvasback at full speed might give the automobile a race.

169

There is, to be sure, one way in which the bird might get the better of a machine, thanks to its capacity to rise to a height. This would be by taking a sloping course downward. The little shore-

lark often gives an exhibition of the possibilities open to the bird in this direction. After rising to a cloudlike height it soars about for a time singing, then suddenly sweeps downward, and, closing its wings, launches itself directly toward the earth, falling with meteoric speed till it almost reaches the surface, when it makes a parachute of its wings and swoops away in safety. During this performance the little lark is, I veritably believe, the swiftest-moving animate thing in all the world. But there is a reason why the bird could not increase its speed indefinitely by imitating the lark's feat in a modified form, and this is the obstacle of atmospheric pressure. Air moving at the rate of sixty feet a second constitutes a serious storm; at ninety feet it becomes a tornado, and at one hundred and fifty feet it is a tornado at its worst—a storm that tears up trees and overthrows houses, and against which no man can stand any more than that he could breast the current of Niagara. Now, of course, it is all one whether the air moves at this rate against you or whether you move at a corresponding rate against the air—action and reaction being equal. Therefore a very serious check is put upon the bird's flight; and it is this consideration which makes it seem doubtful whether any bird, except when aided by a strong wind, can attain such speeds as have been suggested.

170

Of course, atmospheric pressure affects the automobile no less than the bird. In record-breaking speed tests of the automobile, machine and driver are in effect subjected to the influence of a veritable tornado. Theoretically it seems almost incredible that any power could drive a ton of metal against the air at such a speed; practically we see the feat accomplished. But the automobilist has tales to tell of the power of the wind against his face that are easily credible. Even at ordinary speed in a touring-car, as most of us can testify, the wind blows a gale, veritably forcing tears from the eyes of the novice and blowing them back over his ears. To modify the antagonism of the wind, the constructors of racing motor cars adopt a model suggested originally by the body of a bird or of a fish, and long since made familiar by the shipbuilder.

A MIRACULOUS TRANSFORMATION OF ENERGY

Most of the automobiles, as everybody is aware, are propelled by gasoline engines. This is not their least wonderful feature. To the ordinary observer it seems quite incredible that a little whiff of air mixed with the fumes of a few drops of gasoline should produce a power that can drive pistons with such force as to throw forward what is virtually a bullet weighing more than a ton.

The power that propels this amazing projectile consisted in the aggregate of a few cubic feet of gaseous vapors. The forward motion of the piston sucked a whiff of the gasoline vapor and air into the cylinder; the backward motion of the piston compressed this gas; an electric spark ignited it; the heat of the electric spark enabled the gasoline molecules to unite with the oxygen molecules with explosive suddenness; the conflagration thus started spread instantly to other parts of the compressed gas; the myriad particles of the gas rebounding from one another at inconceivable speed, pressed with the aggregate power of multitudes upon the cylinder, and drove it back with terrific force; then an escape valve opened; the return thrust of the piston drove out the exploded gas, and one revolution of the engine was complete.

171

Over and over again this cycle was repeated; each revolution requiring for its performance but a bare fraction of the time required to describe it. The thing is simple enough in practice, but it is a marvelous mechanism when you stop to think of it. That such power should be latent in a seemingly harmless whiff of gas is one of Nature's miracles. And that man should have constructed an engine so nicely adjusted in all its parts as to utilize this power is little less than a miracle of mechanics.

A word should be said about another interesting mechanism that pertains not indeed to the speed of the automobile, but to an accurate record of that speed. That is an electrical timing-device with which absolute accuracy of timing is assured. A moment's reflection will show that it would be quite impossible to time the automobile moving at record speed by the old stop-watch method. The nervous impulse through which the mandate of the brain is conveyed to the hand, and thus made to operate on the stop-watch, travels along the nerve of the arm at the rate of not much more than a hundred feet a second. The delay thus involved, added to the time required for the brain itself to act on the message from the eye, is distinctly appreciable, and every one is aware that individuals differ as to their reaction time.

172

The practical result, therefore, is that timers are often at variance to the extent of as much as two-fifths of a second. Now in two-fifths of a second, as we have seen, the record motor car covers a distance of over 77 feet. Obviously such latitude in measurement could not be permitted. Hence an electric device has been elaborated which tests the speed with absolute accuracy, recording it automatically on a strip of tape. Therefore the fractional seconds are now stated in hundredths instead of in mere quarters or fifths, and we may be confident—as we could not always be regarding the old-time records—that the different fractions of a second represent an actual difference of speed.

It may be of interest to make a further comparison between the speed of the record automobile and the fastest speed ever attained by a railway locomotive—namely, a mile in thirty seconds. The gap is by no means an insignificant one. A mile in thirty seconds means 176 feet a second. This would allow the champion automobile a lead of over seventeen feet each second; and at the end of a mile the locomotive would be distanced by 1040 feet. It is interesting to visualize the procession that the automobile would leave behind if placed in competition with the various kinds of champions whose feats have been mentioned. As the automobile crossed the line

173

the locomotive would be almost one-fifth of a mile in the rear; 1,900 feet farther back would come the homing pigeon; after a long gap Salvator, the first runner, would come straggling along, having covered little more than one-fourth of a mile; Lou Dillon would be just beyond her first fifth of a mile; the fastest cyclist would be placed between the racer and the trotter; while Hutchins, the swiftest runner at the distance, would have gone only 240 yards from the tape.

For distances greater than two miles, the locomotive record has not as yet been surpassed by the automobile. A locomotive on the Plant system, for example, is credited with a run of five miles in two and one-half minutes (in 1901). But, of course, there is nothing except the mere matter of speed that makes the locomotive engineer's performance comparable to that of the chauffeur. The engineer is driving a machine that runs on a fixed track. He has to do little more than keep up steam and open the throttle. The chauffeur must pick his course, for at any moment a soft spot in the sand may tend to deflect him. How appalling may be the result of a slight deflection with a machine going at great speed has been illustrated by the tragic accidents that have marred the success of many important racing-events, and have led to the oft-repeated question as to whether, after all, such speed tests are worth while. It is a question that everyone must answer for himself. The dangers are obvious; but, on the other hand, most athletic competitions have an element of danger; and enthusiasts may well contend that speed tests make for progress, and are largely responsible for the great mechanical improvement that is in evidence.

174

175

THE DEVELOPMENT OF ELECTRIC RAILWAYS

THE United States has been preëminent in the development of street railways of all kinds, from the earliest type of horse-car to the modern city and interurban electric cars. Nevertheless, very few of the great general underlying principles upon which these numerous inventions are based have been discovered upon this side of the Atlantic. American inventors have simply excelled in applying the known general principles to practical mechanisms. But although the American inventors have largely monopolized this field of progress, the names of many Europeans also are connected with it. In several instances these foreign inventors, as naturalized American citizens, have done their work in America, being attracted to this country by the exceptional opportunities offered.

In recent years the city of New York has not shown conspicuous activity in adopting innovations and improvements on its street-railway lines. Nevertheless, New York was the first city in the world to have a passenger street railway. This, built in the early 20's, and running along Fourth Avenue, had rails made of straps of iron laid on stone ties. On this primitive line an omnibus horse-car, called the *John Mason*, was operated. This car was built on the lines of the early railway carriages, having three compartments, with doors opening at the sides. It was, in short, an early type of the side-door cars now used so universally on all European railways. The driver's seat was high in the air as in the case of the ordinary omnibus, and there were seats on the top for passengers.

176

For several years this primitive road remained the only street railway in existence. But it did not prove a particularly good business venture, and for some time capitalists were wary of investing their money for the construction of other lines. Twenty years later, however, a somewhat similar road, considerably improved, was built on Sixth Avenue. This proved to be a financial success; other lines were soon constructed, and the era of street railways opened.

The great advantage of these horse-car lines over the system of omnibuses then in use lay in the fact that greater loads could be hauled with the same expenditure of horse-power, regardless of weather conditions. The contrast in this respect was particularly marked in American cities where the streets, almost without exception, were badly paved.

By 1850, several cities in the United States had installed street railways; and by 1870 over a hundred lines had been built. Between 1870 and 1890 this number had been increased to over seven hundred, not taking into account the numerous extensions that had been made to many of the older lines.

177

CABLE SYSTEMS

Even in the early days of street-railway construction the extravagance of the method of horse-power traction was fully appreciated, and the numerous improvements in steam-engines stimulated attempts to adapt the locomotive in some form to city railways. But there were many difficulties in the use of the ordinary, or specially constructed, locomotives in the crowded thoroughfares of the larger cities. It was practically impossible to eliminate their smoke; and their puffing and wheezing, which frightened horses, caused numerous accidents. But even if these defects could be corrected, the locomotive was known to be an expensive form of motive power, when applied to a single short car, carrying at most only a few passengers and making frequent stops, as was necessary in street-car traffic. The inventors, therefore, looked about for other methods of applying steam power. But it was not until 1873 that this idea took the practical form of the cable road, on which single cars could be operated by means of underground cables travelling in slotted tubes, and propelled from a stationary power-plant.

The first practical cable system was made by Andrew S. Hallidie, and his associates, who planned and put into operation the first cable line in San Francisco. It proved to be entirely successful, and was imitated almost immediately in most of the larger cities of the United States, and in some European cities. Within a decade the number of cable railways installed had so reduced the number of horses necessary for operating street-car lines all over the country that there was an appreciable depression in the market prices of such horses.

178

The importance of this method of transportation is shown in the fact that between the years 1873 and 1890 more than a thousand different patents directly connected with the operation of cable roads were issued by the United States Patent Office. But by 1890 electric traction had become practical, and the issuing of patents for cable lines ceased as abruptly as it had begun. Before the close of the century practically every important cable line in the United States had changed its motive power to electricity. Thus in a brief quarter of a century this method of street-car traction had come into existence, revolutionized all hitherto known methods, and become obsolete.

EARLY SELF-CONTAINED SYSTEMS

In most of the earlier attempts to solve the problem of electrical propulsion the motor vehicles were constructed on a self-contained plan—that is, the power was generated on the locomotive itself, just as in the case of the steam locomotive. As early as 1835 Thomas Davenport, a blacksmith of Brandon, Vermont, constructed such a motor operated by cells, and built a small circular railway in Springfield, Massachusetts, on which he drove this electro-magnetic engine. This miniature railroad was of no practical importance, but it has the distinction of being the pioneer electric road.

Shortly after this, Prof. Moses G. Farmer, a distinguished American inventor and investigator, constructed an electro-magnetic locomotive, which drew a little car, and carried passengers, on a track a foot and a half wide. The locomotive used about fifty Grove cells, which developed a relatively small amount of energy at an enormous cost.

"In 1850-51," says Martin, "Mr. Thomas Hall, of Boston, exhibited a small working-motor on a track forty feet long, at the Mechanics' Charitable Fair in Boston, and while this was a mere toy, and used but a couple of cells of battery, it sufficed to illustrate the principles of a motor or locomotive with a single trial car. About this time (1847) an interesting demonstration was also made with a small working-model, one of the features of which has been most instrumental in the success of the modern electric methods, that of the utilization of the track as part of the return circuit for the current. Doctor Colton, once a famous dentist in New York City, and noted for his early application of laughing-gas in that work, was associated with Mr. Lilly in the construction and operation of a small model locomotive which ran around a circular track. The rails were insulated from each other, each connecting with one pole of the battery. The current from the battery was taken up by the wheels, whence it passed to the magnets, upon whose alternating attraction and repulsion motion depended; then it returned to the other rail, connected the other pole of the battery, and thus completed the circuit necessary for the flow of the current. In like manner in a great majority in use at present, the current passes from one power-house to circuits of one polarity, through the trolley pole to the motor or electro-magnetic propelling system, thence through the wheels to the track, which completes the circuit by being connected to the other pole or side of the dynamo at the power-house. The principles are obviously identical, but it took more than a quarter of a century to develop the proper method of application in all its details.

"The most serious and sustained attempt in the early period to operate a self-sustained vehicle or car—which would correspond with the storage-battery cars—was that due to Prof. C. C. Page, of the Smithsonian Institution. About 1850, Professor Page devoted considerable time to the development of electric engines or motors, in which the reciprocating action of a system of magnets and solenoids or armatures was applied by crank-shafts to driving a fly-wheel, to which rotary motion was thus imparted. This reciprocal motion, as in steam-engines, was one of the prevailing features of the early electric-motor work in this country and in Europe; but it was not long before its general inapplicability was realized, and it was abandoned for the simpler and more direct rotation of the armature before or between the poles of electro-magnets.

"On April 29, 1857, with an electric locomotive on which he had installed a large reciprocating motor developing over 16 horse-power, Professor Page made a trial trip along the track of the Washington and Baltimore Railroad, starting from Washington. In order to obtain current for energization, the motor was equipped with one hundred cells of Grove nitric-acid battery, each having as one element a platinum plate eleven inches square, dipped in the acid. Bladensburg, a distance of about five and one-quarter miles, was reached in thirty-nine minutes, and a maximum speed of nineteen miles an hour was attained; the entire trip to and from Bladensburg occupied one hour and fifty-eight minutes. But many disasters happened to the batteries. Some of the cells cracked wide open, and jolts due to inequalities of track threw the batteries out of working order. These experiments must have been extremely costly, and no little discouragement among people in general attended this failure; but Professor Page was not daunted, and for some years continued his work on electric motors, displaying great ingenuity, but not able, apparently, to give up the reciprocating principle."

The invention of the commercial dynamo, shortly after the middle of the nineteenth century, opened the era of practical electric-railway construction on both sides of the Atlantic. The German experimenters, Siemens and Halske, and later the American, Stephen D. Field, paved the way by numerous experiments and discoveries. It was not until about 1880, however, that the idea of using a third rail for transmitting the current was conceived. Hitherto, most of the inventors had attempted to use one rail as a receiving part of the circuit to the motor, the other rail completing the return part of the circuit. And it was several years after the idea of the third rail had germinated before the attempts to utilize one of the traction rails for conveying the current was abandoned.

THE EDISON ELECTRIC LOCOMOTIVE

In 1880, Mr. Thomas A. Edison, at Menlo Park, New Jersey, perfected a series of electric-railway motors and locomotives that were actually employed in hauling freight and passengers. The following year Mr. Edison made a contract with Mr. Henry Villard, which stipulated that the inventor was to construct an electric railway at least two miles and a half in length, which was to be equipped with two locomotives and three cars, one locomotive for freight and one for passengers, the passenger locomotive to have a capacity of sixty miles an hour. It was agreed that if the experiment with this railway proved successful Mr. Villard was to reimburse Mr.

Edison for the actual outlay, and to install at least fifty miles of electric road in the wheat regions of the Northwest.

The electric locomotives built by Mr. Edison were constructed along the usual lines of steam locomotives, with cab, headlight, and cowcatcher, the motive power being applied from the motors to the axle by means of friction pulleys. This method was soon abandoned, as the pulleys slipped a great deal before the locomotive actually started. A system of belts which was substituted proved more satisfactory. The current was conveyed to the motor through the track, and was supplied to the road by underground cables connecting from the dynamo-room of Mr. Edison's laboratory. The rails were insulated from the ties by coatings of Japan varnish, and by placing them on pads made of muslin impregnated with tar.

From the very first this road gave promise of success. The tireless genius of Edison was constantly finding and correcting defects, and there was every prospect that in a few months a practical and economical electric railway would be an accomplished fact. Then came the financial crash of the Northern Pacific Railway, involving the fortune of Mr. Villard, and tying the hands of the inventor at Menlo Park for the time being.

The year following, however, Mr. Field and Mr. Edison combined their forces and formed a company for perfecting and constructing electric locomotives and railways. In the same year an electric railway was put in operation at the Chicago Railway Exposition, the chief promoters of this enterprise being Messrs. Field, F. B. Rae, and C. O. Mailloux. In the gallery of the building a circular track, something like a third of a mile in length, was laid, and on this an electric locomotive named *The Judge* hauled a single car which carried over twenty-six thousand passengers in the month of June. In the autumn of the same year, *The Judge* was used for hauling passengers on a track at the Louisville Exposition. It was capable of attaining a speed of twelve miles an hour, and its average speed was eight miles. It was twelve feet long over all, weighed something like three tons, and, like Edison's locomotive, was equipped with cowcatcher, headlight, and cab. The current was taken from a surface, or feed rail, by means of bundles of phosphor-bronze wire, so arranged that a good clean contact would be made on each side of the rail whether the car was moving forward or backward.

THIRD RAILS AND TROLLEYS

At the same time an Englishman named Leo Daft, then living in America, was making some important experiments with motors for the purpose of driving machinery, these motors being operated from central power-stations located at distant points. Mr. Daft constructed an electric locomotive, and in November, 1883, constructed what was known as the Saratoga and Mount MacGregor Railroad. This railroad was twelve miles in length and included many steep grades. The locomotive, which hauled a regular passenger-car, received the current from a central rail. The year following Mr. Daft built and equipped a small road on one of the long piers of Coney Island, which carried something like forty thousand passengers in one season. It was an improvement over the Siemens electric railway established in Germany in 1881—which, however, was the first road ever established.

The following year the inventor began the equipment of the Baltimore Union Passenger Railway Company, a line that ran a distance of about two miles and reached an elevation of one hundred and fifty feet above the city of Baltimore. This road was put into regular operation in 1886, and was the second electric street railway in America for carrying on regular passenger service.

The Baltimore Union Railway had several novel and important features, one of them being the equipment of part of the line with an overhead-trolley service, the practical importance of which had been demonstrated shortly before by Van Depoele. The projector, Mr. Daft, also built several other lines in different parts of the country, constantly improving upon his earlier efforts, sometimes using two overhead trolley wires, with two trolley contacts, thus doing away with the use of the track as a means of current supply, or for use as part of the circuit. Although in recent years double overhead trolleys have largely disappeared, some of them are still in use both in America and in Europe.

Van Depoele was a Belgian who had come to America in 1869. Although primarily a cabinet-maker, he had a great liking for the study of electricity, and devoted all his spare time and money to efforts to solve the problem of practical street-car propulsion. In 1883, at the Industrial Exposition at Chicago, he operated a car by electricity, using an overhead-trolley system somewhat similar to Daft's. By 1885, he had made sufficient progress to construct a line one mile long for carrying passengers from the railway station to the Annual Exhibition grounds at Toronto, Canada. On a single track he operated three cars and a motor, carrying an average of ten thousand passengers daily, his train sometimes attaining a speed of thirty miles an hour. For receiving the current he used an underrunning trolley and pole very similar to the form now in common use, this being one of the first instances of employing this particular method of receiving the current. In this system an insulated track was used for returning the current.

Van Depoele's next venture was the equipment of an electric railway at South Bend, Indiana, on which five separate cars were operated at one time—a thing supposed by many to be impossible. The cars of this road were equipped with motors placed under the cars instead of above them, thus saving valuable seating-space. In place of the underrunning trolley and pole, however, the current was taken from the overhead wire by means of a flexible cable. Later Van

Depoele invented an underrunning trolley and pole, taking out the original patents. His claims to priority were contested eventually, but they were sustained by the United States courts.

At this time there were at least a score of inventors whose work added something of importance to the solution of the problem of electric traction. But without belittling others, it is probably only justice to say that the work of Frank J. Sprague, a one-time lieutenant in the United States Navy, marks the beginning of the modern era of street railways. In 1888, after a period of struggle and a series of disheartening disasters, Mr. Sprague and his associates opened an electric line for the Union Passenger Railway of Richmond, Va., which "forms a landmark in the history of this industrial development." Over a line of road with grades at that time considered impossible, thirty cars were put into use at the same time, the contract for the equipment calling for its completion in ninety days. The success of this enterprise, when on the opening day more electric cars were operated than in all the rest of America together, settled forever the question of the practicality of electric street railways, as well as many of the questions of the practical application of the current, thanks to Sprague's inventive genius.

This road was an overhead trolley-wire system, with an underrunning trolley held in place by the now-familiar trolley pole. The number of difficulties that had to be solved in perfecting this apparently simple piece of apparatus is shown by the statement of Mr. Sprague that "probably not less than fifty modifications of trolley wheels and poles were used before what is known as the 'universal movement' type was adopted."

In this connection the origin of the word "trolley" is interesting. It seems to have been corrupted from the word "troller" by the workmen of a Kansas City car-line. On this line an overhead wire was used, the travelling carriage taking the current from the wire being known as the "troller." The employees of the road, however, shortly corrupted "troller" into "trolley"; and "trolley" it has remained ever since.

As in the case of Van Depoele, whose perfection of the underrunning trolley was contested legally, Sprague's great contribution to electric traction, the suspension of the motor directly upon the axle, had finally to be sustained by the United States courts. Sprague's method was to hang the motor under the car directly upon the axle, by an extension or solid bearing attached directly to the motor. This plan of constructing the motor, together with numerous other improvements, principally in the direction of lightness, simplicity, and adaptability, soon superseded all pre-existing methods of construction. Thus Van Depoele's method of taking the current from the wire, and Sprague's method of utilizing it in the propulsion of the car, must be regarded as epoch-marking steps in the history of electric traction. Sprague's invention demonstrated the validity of his contention, now universally accepted, that motors should be placed under each car instead of being used on locomotives.

STORAGE-BATTERY SYSTEMS

From the earliest attempts at solving the question of electric traction, efforts were made to produce some form of storage battery whereby the cars might be made independent of a distant generating plant. The advantages of a self-contained vehicle are so obvious that it is not surprising to find the inventors persistent in their attempts at producing practical cars of this type. Such battery cars would not require the dangerous, expensive, and cumbersome system of overhead wires, or the more sightly but also more expensive system of conduits. With such a system of cars the elaborate mains and feeders for bringing the current to the track from the power-house, and for effecting the return circuit, could be dispensed with. Moreover, the independent action of such cars over a system where the power is furnished from a single source, where the stoppage of the current stops every car along the line, is inestimable.

Between the years 1880 and 1883 many storage-battery cars were built and put in service both in European and American cities. Probably the most important one of these lines was that which was built by the Belgian, Mr. E. Julien, in New York city, in 1887-8. On the Fourth Avenue road something like a dozen storage-battery cars were put in operation for a considerable time, and later, improved modifications of these cars were operated in Philadelphia under the direction of Mr. Anthony Rackenzaun, of Vienna. But despite the apparent simplicity of the storage-battery idea, innumerable difficulties were perpetually presenting themselves in its practical application. Despite the disheartening results, however, storage-battery cars were not entirely abandoned in practice until 1903, New York city being the last to surrender, as it had been about the last to adopt them.

But in February, 1910, the storage-battery street car again made its appearance on trial in New York—not the old heavy type of unsatisfactory car, but an entirely new and lighter creation of Thomas A. Edison, who had been striving for years to solve the storage-battery problem. This car, which had been tested on the Orange, New Jersey, street-car line on January 20th, 1910, maintained a speed of fifteen miles an hour in actual practice, and ran a distance of about one hundred and fifty miles without re-charging the batteries.

There are some novel features about the car itself, but the all-important one is the peculiar and novel storage battery which it has taken Mr. Edison some nine years to perfect. In an imperfect form this battery was given a trial in 1903, and much was expected of it because it was not only lighter than the usual form of storage battery, but it promised more permanency because an alkali was used in place of an acid as an electrolyte.

In this battery the positive element, which consisted of nickel oxide interspersed with layers

of graphite, was packed in perforated nickel tubes. The negative element was iron oxide, with potassium hydrate as the electrolyte. This battery showed no bad effects from over-charging or from being rapidly discharged, but it was found that the graphite soon became oxidized and interfered with the working of the battery. This defect was corrected by substituting chemically pure nickel for the graphite, but another was soon discovered. Under the pressure of the oxide of nickel the square tubes containing the nickel were frequently injured so that the powdered nickel oxide was sifted down on the pure nickel layers and insulated them.

The only solution of this difficulty seemed to be to pack the nickel in strong round tubes four inches long and about the size of a lead pencil, the sides of the tubes being finely perforated. But the expense of producing such tubes by ordinary methods was prohibitive. A machine was finally invented, however, which made the tubes economically by using spirally wound ribbons of metal, the edges being fastened together during the coiling process. By the use of these tubes the battery was so far perfected that it was given extensive trials in 1908 on electric vehicles; and as these tests proved satisfactory, Mr. Edison began the construction of a specially designed street car equipped with two 5-horse-power 110-volt motors of very light construction. The car weighs complete about five tons, and the batteries are stored under the seats running along each side.

This car was tested continuously for three weeks on one of the New York cross-town lines and performed its work so satisfactorily and economically that the management of the line decided to give the system a permanent trial. The regular daily run of this car averaged something over sixty-six miles, but this by no means exhausted the capacity of the batteries; and it is estimated that it could easily have run at least one-quarter farther without re-charging. The surprising feature of these tests was the low cost of running. The total cost of electric power for the day's run was about thirty cents, or 4.3 mills for each mile. The ordinary New York street car costs on an average about five cents per mile for electrical energy; but on the other hand, the carrying capacity of these cars is almost twice that of the Edison car.

The actual cost of running the car, however, was only one of its many advantages. The fact that no underground conduits have to be laid or overhead wires erected and maintained makes the initial cost of installing the line far less than by any other system. The reduction in the cost of maintenance of the line is also an important item, as it is estimated that the cost of repairs on conduit lines is about \$15,000 annually per mile.

But the most convincing proof that Mr. Edison has really produced a practical storage battery car lies in the fact that, after testing his car for three weeks in actual traffic, the managers of the street-car line ordered sixteen similar cars for operation over their road.

MONORAIL SYSTEMS

The introduction of electricity facilitated the construction of monorail systems of roads, which had long been the dream of railroad constructors, since this power could be applied with so much more flexibility. The defects of the parallel rail system are apparent both in construction of the roadbed and the operating of trains. It is almost impossible to lay and maintain the rails in exact parallels, and even more difficult to keep each rail at the proper height at all points. Both these factors enter very largely into the determination of the speed that a train can make over such tracks, any very great variation from the parallel causing derailment, while slight depressions or elevations of either rail cause violent and dangerous rocking of the cars travelling at high speed.

In any monorail system the first of these difficulties, the deviation of the rail from the parallel, is, of course, eliminated; and it is found that on a single rail the elevations and depressions are not serious obstacles. Moreover, the cost of construction of a single-rail track must obviously be less than for a double-rail track, and the power necessary to operate cars over such a track far less. But until the invention of the gyrocar (which is referred to at length in the following chapter) the methods of balancing the car on a single rail presented difficulties which quite offset the advantages of the monorail system. Some of these methods are unique and a few of them are practical in actual operation.

In Germany a suspension monorail system is in operation, the cars being suspended from an overhead track. But obviously such a system, which requires elaborate and expensive steel trestle-work along every fork of the road, is not adapted to the use of long-distance roads except in thickly populated districts. A less expensive and highly satisfactory system is the one invented by Mr. Howard Hansel Tunis and used at the Jamestown Exhibition in 1907.

In this system the wheels, arranged in tandem, have double flanges which keep them on the single-rail track, and the cars are prevented from toppling over by overhead guides. These guides must be supported on a frame-work, but as there is little tendency to sway on a single-rail track, they can be relatively light structures. It is the cost of these frames, however, that practically offsets the low cost of road-bed construction, so that, everything considered, the mere matter of initial cost has no very great advantage over the ordinary double-rail road. But the cost of operating is considerably less than the older type, and this road would undoubtedly come rapidly into popularity but for the fact that such gyrocars as the ones invented in England and Germany are self-sustaining on the rail, doing away with the expensive overhead frame-work construction, and are likely to become practical factors in the problem of transportation.

In 1909 an electric aerial monorail up the Wetterhorn in the Alps was put into operation. On this line a car suspended on two cables, one above the other and without supports except at the upper and lower terminals, rises at an angle of forty-five degrees through a distance of 1,250

feet. There are two sets of these cables, each carrying a car so arranged as to work in alternate directions simultaneously, this counter-balancing effecting a great saving in power. The power-plant is located at the upper end of the ascent, and consists of winding drums actuated by electricity which raise and lower the cars by means of cables. On the cars themselves, therefore, there is no power, but each car is equipped with brakes powerful enough to stop and hold it notwithstanding the steepness of the incline.

There is nothing particularly novel in the principles involved in this aerial road, but it is the first of its kind to be built for passenger traffic. Similar less pretentious roads have been in use for freight transportation for several years. But the success of this road means the building of others on inaccessible mountain inclines where the laying of ordinary roadbeds is out of the question, and the operating of cog roads too expensive.

VII

THE GYROCAR

ON the 8th of May, 1907, Mr. Louis Brennan exhibited, at a *soirée* of the Royal Society in London, a remarkable piece of mechanism, which stirred the imagination of every beholder, and—next morning—as reported by the newspapers, aroused the amazed interest of the world. This invention consists of a car run on a single rail, standing erect like a bicycle when in motion; but, unlike the bicycle, being equally stable when at rest.

It is a car that could cross the gorge of Niagara on a tight-rope, like Blondin himself, but with far greater security; a car that shows many strange properties, seeming to defy not gravitation alone but the simplest laws of motion. For example, if a weight is placed on one edge of the car that side rises higher instead of being lowered.

If you push against the side with your hand, the mysterious creature—you feel that it must be endowed with life—is actually felt to push back as if resenting the affront.

Similarly, if the wind blows against the car, it veers over toward the wind. If the track on which it runs—consisting of an ordinary gas-pipe or of a cable of wire—is curved, even very sharply, the car follows the curve without difficulty, and, in defiance of ordinary laws of motion, actually leans inward as a bicycle rider leans under the same circumstances, instead of being careened outward as one might expect.

196

A curious mechanism, surely, this new car, with its four wheels set in line, bicycle fashion, running thus steadily. But strangest of all it seemed when it poised and stood perfectly still on its tight-rope, as no Blondin could ever do. As stably poised it stood there as if it had two rails beneath it instead of a single wire; and there was nothing about it to suggest an explanation of the miracle, except that there came from within the car the murmur of whirling wheels.

The mysterious wheels in question would be found, if we could look within the structure of the car, to be two in number, arranged quite close together on each side of the centre of the car. They are two small fly-wheels, in closed cases, revolving in opposite directions, each propelled by an electric motor. These are the wonder-workers. They constitute the two-lobed brain or, if you prefer, the double-chambered heart of the strange organism. All the world has learned to call them gyroscopes. The vehicle that they balance may conveniently be termed a gyrocar—a name that has the sanction of the inventor himself.

Let it be understood once for all that a gyroscope is merely a body whirling about an axis. A top such as every child plays with is a gyroscope; a hoop such as every child rolls is a gyroscope; the wheels of bicycles, carriages, or railway-cars are gyroscopes; and the earth itself, whirling about its axis, is a gyroscope. You can make a gyroscope of your own body if you choose to whirl about, like a ballet-dancer. In a word, the gyroscope is the most common thing imaginable. Indeed, if I wished to startle the reader with a seeming paradox, I might say without transcending the bounds of truth that, in the last analysis, there is probably nothing known to us in the universe but an infinitude of gyroscopes—atoms and molecules at one end of the scale; planets and suns at the other—all are whirling bodies. Still there are gyroscopes and gyroscopes, as we shall see.

197

GYROSCOPIC ACTION EXPLAINED

Now a word about gyroscopic action. If you have rolled a hoop or spun a top you have unwittingly learned some practical lessons on the subject which, had you possessed Mr. Brennan's imagination and ingenuity, might have enabled you to anticipate him in the invention of the gyrocar. Harking back to the days when you rolled hoops, you will recall that the child who most excelled in the art was the one that could make the hoop go fastest. The hoop itself might be merely a wheel of wire, which would fall over instantly if not in motion; but if given a push it assumed an upright position and maintained it with security, so long as it was impelled forward. It seemed able, so long as it whirled about, to defy the ordinary laws of gravity. A bicycle in motion gives an even more striking illustration of the same phenomenon. And best of all, a spinning-top. Everyone knows how this familiar toy, which topples over instantly when at rest and can in no wise be balanced on its point, rises up triumphant when whirled about, and stands erect, poised in a way that would seem simply miraculous to all of us, had we not all spun tops at an age when the world was so full of wonders that we failed to marvel at any of them.

198

All these familiar things illustrate one of the principles of gyroscopic action which Mr. Brennan has put to account in developing his wonderful car—the fact, namely, that every revolving body tends to maintain its chief axis in a fixed direction, and resents—if I may be permitted to use this expressive word—having that direction changed. The same principle is illustrated on a stupendous scale by our revolving earth, which maintains the same tilt year after year as it whirls on its great journey, notwithstanding the fact that the sun and the moon are tugging constantly at its protuberant equatorial region in a way that would quickly change its direction if it were not spinning.

But note, please, that whereas the whirling body assumes a certain rigidity in space as regards the direction in which its axle points, the mere translation of the body itself through

space in any direction is not interfered with in the least, provided the axle is kept parallel with its original position.

You may test this if you like in a very simple way. Remove one of the wheels of your bicycle, and carry it about the room, holding it by the axle while it is spinning rapidly. You will discover that it requires no more force to carry it when spinning than when at rest, provided you do not attempt to tip it from its plane of rotation, but that if you do attempt so to tip it, the wheel seems positively to resist, exerting a force of which it did not show a trace when at rest. A large top, arranged within the kind of frames or hoops called gimbals, if you can secure such a one, will show you the same phenomenon; it will resist having its axis diverted from the direction it chanced to have when it was set spinning.

199

If you ask why the spinning wheel exerts this power, it may not be easy to give an answer. The simplest things are hardest to explain. No man knows why and how gravitation acts; no one knows why a body at rest tends always to remain at rest until some force is applied to it; nor why when a body is once in motion it tends always to move on at the same rate of speed until some counter-force stops it. Such are the observed facts; they are facts that underlie all the principles of mechanics; but they are matters of observation, not of explanation or argument. And the fact that a revolving body tends to maintain its axis in a fixed position is a fact of the same category.

So far as we can explain it at all, we may, perhaps, say that the inertia which the matter composing the wheel shares with all other matter is accentuated by the fact that its whirling particles all tend at successive instants to fly in different directions under stress of centrifugal force. At any given instant each individual particle tending to fly off in a particular direction may be likened to a man pulling at a rope in that direction.

If you imagine an infinite number of men circled about a pole to which ropes are attached, and evenly distributed, each one pulling with equal force, it will be clear that the joint effort of the multitude would result in fixing the pole rigidly at the centre. The harder the multitude pulled, so long as they remained evenly distributed about the circle, the more rigid the pole would become. But if, on the other hand, all the men were to stop pulling and slacken the ropes, the pole would at once fall over. The pole, under such circumstances, would represent the axis of the revolving wheel, which acquired increased stability in exact proportion to the increased velocity of its revolutions, and therefore of the increased force with which its particles tend to fly off into space.

200

But be the explanation what it may, the fact that the axis of a revolving wheel acquires stability and tends to maintain its fixed position in space is indisputable; and it is this fact which determines primarily the action of the little revolving wheels of the gyroscopes that balance Mr. Brennan's car. There are certain very important additional principles involved that I shall refer to in a moment, but first let us glance at the car itself and see how the gyroscopes are arranged. We shall find them fastened within the frame-work of the car, at its longitudinal centre, in such a way that their axles are parallel to the axles of the ordinary car-wheels when the car stands in a normal position. Granted that the gyroscopes are thus transverse and normally horizontal, and at right angles to the track, the exact location of the mechanism within the car is immaterial. But the two gyroscopes must revolve in opposite directions for a reason to be given presently.

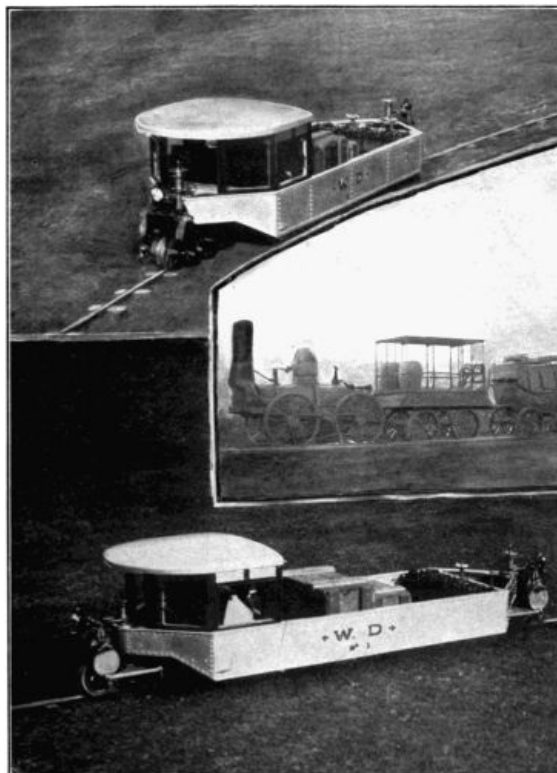

RETROSPECT AND PROSPECT IN TRANSPORTATION—THE DE WITT CLINTON TRAIN AND THE GYRO-CAR.

The De Witt Clinton engine, with its archaic coaches, represents the earliest type of railway transportation in America. The Gyro-car, two views of which are given, is the working model of a single-rail vehicle exhibited in England by Mr. Louis Brennan in 1907. It is balanced by an ingenious gyroscopic mechanism, which its inventor believes will prove equally successful when applied to vehicles on a commercial scale.

MR. BRENNAN'S MODEL CAR

The Brennan car as at first exhibited was only a working-model about six feet in length, and the gyroscopes that balanced it were about five inches in diameter. It seems almost incredible that wheels so small should be able to balance a car six feet in length, but it must be understood that these small gyroscopes whirl at the rate of about seven thousand revolutions per minute, and, of course, the gyroscopic force is proportionate to the rate of revolution. If we recall that a light hoop making perhaps fifty or a hundred revolutions per minute acquires a considerable stability, we shall cease to wonder at the rigidity of the axles of the wheels revolving at such enormous speed.

201

The model car accomplished the feat of carrying a passenger weighing about one hundred and forty pounds across a little valley on a wire cable, a voyage in some respects the most remarkable that any man has thus far been privileged to make. The car has shown that it can go up or down a sharp incline; but this, as a moment's reflection will show, does not involve any change of direction of the gyroscopic axle, and therefore involves only the ordinary laws of mechanics. It is all one to the gyroscope whether the car moves on the level or up or down hill, so long as it moves straight ahead.

Nor do the gyroscopes interfere in the least with the turning of the car in passing round a curve, when the two of them are linked together, as Mr. Brennan links them, so that any lateral change in the axis of one is balanced by an opposite change of the axis of the other. With the single gyroscope, such as Mr. Brennan used when he first began his experiments, the car encounters difficulties at curves in the track.

But before we can understand how the two gyroscopes balance each other in such a way as to make the Brennan car lean in while passing about a curve, we must investigate more fully the action of the individual gyroscopes. I have already said that there is another principle involved as supplementary to the principle of the fixed axis; this we must now investigate.

202

Perhaps it would be fairer to say that what we have to consider is not a new principle but a complication as to the application of the principle of gyroscopic action already put forward. In any event there is an elementary fact about the gyroscope that I have not yet stated. It is this: in order that the gyroscope may exercise its fundamental property of holding its axis fixed, it must have that axis so adjusted that it is free to oscillate or wobble. That sounds distinctly paradoxical, but it is a very essential fact. If Mr. Brennan had merely fixed two wheels rigidly in the frame of his car, they would have had no appreciable effect in balancing it. Had nothing more than that been necessary, some one would have invented a gyrocar long ago. But very much more than that was necessary, as we shall see.

The complication of which I am speaking is illustrated by the action of the simplest top, which likewise owes its stability to its wobble. Your top does not rise merely because it spins, but because it wobbles as it spins—wobbling being the familiar word for what the machinist calls "precession." A freely spinning top, if in equilibrium, has no inherency to rise up against gravitation, as your top may have led you to suppose. Your top rises because it is not spinning freely in equilibrium, its action being interfered with by the friction of the point on which it rests; it is seeking a position of equilibrium, which, owing to the location of its centre of gravity, will be found when its spindle is erect. But a top supported at both ends and properly balanced, does not tend to rise but only to maintain its position.

203

HOW THE BRENNAN GYROSCOPES WORK

It is such a balanced top as this that we must call to our aid in explaining the action of Mr. Brennan's gyroscopes. The explanation will involve the use of a diagram perhaps rather unpleasantly suggestive of the days when you studied geometry, and I fear I cannot hope to make interesting reading of the explanation. But it will be worth your while to follow it, that you may understand the action of one of the most remarkable and ingenious of inventions. Figure 1 represents a kind of top called a Foucault gyrostat. It is merely a top or gyroscope in gimbal frames, such as I have already referred to. With certain slight modifications, the diagram that represents it might also be a diagram of one of the gyroscopes in Mr. Brennan's car. Indeed, it was such a top as this that led Mr. Brennan to his discovery. Once while on a visit to Cannes, he purchased a top like this of a street vender—and the gyrocar is the outcome of the studies he made with it. This is also the kind of top with which Foucault, after whom it is named, proved that the earth revolves; but we shall come to that story in another connection.

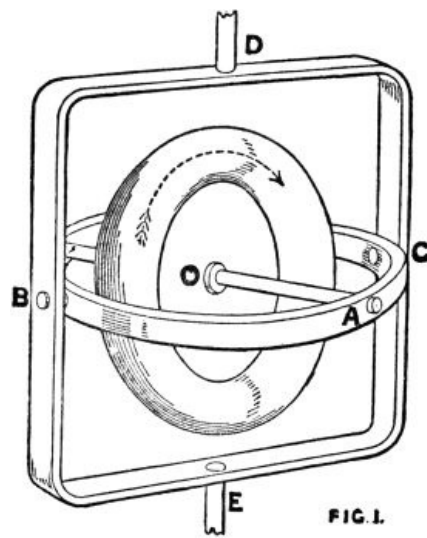

FIG. 1.

Reverting to the diagram, the gyroscope or top proper is at the centre, revolving on the axis $O A$. It is pivoted on the frame $B A C$, which frame is in turn pivoted so that it can rotate on the axis $B C$. Lastly, the outer frame $B D C E$ is pivoted on the axis $D E$. Thus the apparatus as a whole is capable of revolving on each of its three principal axes. But under ordinary conditions it is only the inner wheel that is spinning. As this wheel is perfectly balanced, it will maintain steadily any position that it chances to have when it is set spinning, and the outer frames will remain stationary unless a disturbing force is applied to them.

204

205

Suppose, now, that the wheel has been set spinning on its axis $O A$ in the direction indicated by the arrow, while its axis is horizontal, as represented in the diagram. The wheel will then tend to maintain its position and resist any attempt to displace it. But its resistance will be shown in a very peculiar way—whereby hangs our tale. If you apply a steady downward pressure to the frame $B A C$ at point A , attempting thus to deflect the axis of the spinning wheel of the gyroscope, the frame will not tip down as you expect it to do (and as it would do if the top were not spinning) but instead, it will move in a horizontal plane along the arc $C A B$, the entire mechanism rotating on the axis $D E$. This motion is equivalent to the wobble of the top, and it is called "precession."

Please remember the word and its meaning, for we must use it repeatedly.

But now, curiously enough, if you were to apply a sidewise pressure at A , pushing to the left (as we view the diagram) to help on the motion of precession, the obstinate apparatus will cease altogether to move in that direction and the point A will begin to rise instead, the frame $B A C$ rotating on its axis $B C$. This rise of the axis $O A$ will take place even though the downward pressure is continued. You have disturbed the equilibrium of the top—unbalanced it—and it must seek a new position. Contrariwise, if you would have the point A moved to the right, you must push it upward; if you would have it go down, you must push it to the right.

This seems rather weird behavior, but if you will note the direction of the arrow on the wheel you will see a certain method in it. It will appear that in each case the force you apply has been carried round a corner, as it were, by the whirling disc, and made to act at right angles to the direction of its application. This change of direction of a force applied is strictly comparable to the change effected by the familiar device known as a pulley. With that device, to be sure, a pull instead of a push is used, but this is a distinction without a difference, for pushing and pulling are only opposite views of the same thing.

206

Possibly this suggested explanation of the action of the gyrostat may not seem very satisfactory, but the facts are perfectly clear, and if you will bear them steadily in mind you will readily be able to understand the Brennan gyroscope, as you otherwise cannot possibly hope to do. You have only to recall that pushing down at A causes motion (called "precession") to the left, and pushing up at A , motion to the right; and that in order to make A either rise or fall, you must "accelerate precession" by pushing to the left or to the right, respectively. But you must understand further, that when, through the application of any of these disturbing forces, you have forced the axis $O A$ into a new position, it will tend to maintain that new position, having no propensity whatever to return to its original position. It is quite as stably in equilibrium with its axis pointing upward as when in the position shown in the diagram. One position is quite like another to it; but having accepted a position it resents any change whatsoever.

Now we are prepared to understand the Brennan gyroscope, which consists essentially of two such gyrostats as that shown in our diagram A , set into the frame of the car on the axis $D E$, their wheels revolving in opposite directions and their outer frames so linked together that when one turns in one direction on its axis $D E$, the other must turn in the opposite direction. As the sole object of having two of the gyroscopes is to facilitate the going around curves, we may for the moment neglect the second one, and consider the action of only one of the pair.

207

Our diagram 2, then, will represent one of Mr. Brennan's gyroscopes in action. It is pivoted into the framework of the car on the axis $D E$. If you examine it you will see that it is essentially the Foucault gyrostat of our other diagram, with the axis $O A$ projected beyond the frame to the

point F .

In practice, the frame BAC is made to carry the field-magnet of an electric motor for spinning the wheel. But this in no wise affects the principles of action. Mr. Brennan's invention consists of the exceedingly ingenious way in which he applies these principles; and to understand this we must follow our diagram closely. Looking at it, you will see that the spindle OF carries two rollers R_1 and R_2 which may come in contact under certain circumstances with the curved segment marked G_1, G_2, G_3, G_4 , which are strong segments of the car-frame itself—the segments, indeed, upon which the force of the gyroscope is expended in holding the car in equilibrium. It must be understood further that the roller R_1 is loosely fitted to the spindle OF and hence can whirl with it when pressed against the segment G_1 or G_3 ; whereas the roller R_2 is fitted about a non-revolving extension of the frame BAC , and not to the spindle itself. Bearing in mind that the gyroscope itself is perfectly balanced and hence tends to maintain its axis OF in a fixed direction, we shall be able to understand what must happen when the car is tipped from any cause whatever—as the shifting of its load, the pressure of the wind, or the centrifugal action due to rounding a curve.

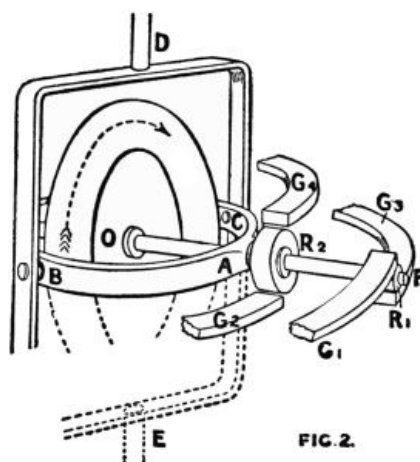

FIG. 2.

Suppose, for example, that the car tips to the right. This will bring the segment G_1 in contact with the roller R_1 , and the roller will instantly tend to run along it, as a car-wheel runs along the track, because friction with the spindle causes it to revolve. But this, it will be evident, is equivalent to pushing the spindle F (or the frame A) toward B —"accelerating the precession"—and we know that the effect of such a push will be to cause the spindle (thanks to that round-the-corner action) to rise, thus pushing up the segment G_1 , and with it the car itself.

The thrust will cause the car to topple to the left and this will free the roller R_2 , but a moment later it will bring the segment G_2 in contact with roller R_2 which thus receives an upward thrust. But an upward thrust, we recall, will not cause the spindle to move upward, but off to the right toward C ; and so, a moment later still the roller R_2 will pass beyond the end of the segment G_2 and the roller R_1 will come in contact with the segment G_3 , along which it will tend to roll, thus accelerating the precession to the right, and so causing the spindle to push downward, bringing the car back to its old position or beyond it; whereupon the segment G_4 will be brought in contact with R_2 , retarding the further oscillation of the car and causing the spindle to move back again to the left.

This sequence of oscillations will be repeated over and over so long as any disturbing force tends to throw the car out of equilibrium. In other words, the gyroscope, when its balance is disturbed by a thrust due to any unbalancing of the car, will begin to wobble and continue to wobble until it finds a position where it is no longer disturbed, and this new position will be attained only when the car as a whole is perfectly balanced again.

In this new position of balance, the car (owing to a shift of its load or to the force of the wind) may be tipped far over to one side, as a man leans in carrying a weight on one shoulder, to get the centre of gravity over the rail, and in that event the axis of the gyroscope will be no longer horizontal. But that is quite immaterial. There is no more merit in the horizontal position than in any other, as regards the tendency to keep a fixed axis. If it is usually horizontal, this is only because under normal conditions the car will be balanced at its physical centre, just as ordinarily a man stands erect and does not lean to one side in walking.

Reverting for a moment to our diagram and the explanation just given, it will be understood that the two rollers R_1 and R_2 are never in action at the same time, and that it is only the roller R_1 that gives the sidewise push that accelerates the precession (since R_2 is not in contact with the axle itself).

The function of R_2 is to retard the precession and bring the axis to its normal position at right angles to the rail on which the car runs. There is nothing of mystery about the action of either

which the action of our gyrostat does not explain, but the mechanism by which the different segments of the car are made to push against the spindle, and so force it to balance the car in order that it may maintain its own balance, is exceedingly ingenious. Mr. Brennan himself tells me that he has improved methods of accomplishing these results, which are not yet to be made public. The principle, however, is the same as that outlined in the earlier patents which I have just described.

If you have taken the trouble to follow carefully the description just given, you will be prepared to understand the anomalies of action of the gyrocar; for example, why its side rises when a weight is placed on it; why it leans toward the wind, and why it leans to the inner and not to the outer side of the track in rounding a curve. The substance of the explanation is that the greater the force brought to bear on the roller R_1 by the segment of the car that strikes against it, the stronger its precession, and hence the more powerful its lift. The oscillations and counter-oscillations thus brought about continue to operate powerfully on the roller R_1 so long as the weight of the car is out of balance; and balance is restored only when the heavier side of the car rises, bringing the centre of gravity over the track, just as a man carrying a weight on the right shoulder leans toward the left, and vice-versa. Thus, when the gyrocar has a heavy weight on one side, or encounters a strong wind, it may lean far over, but still be perfectly and securely balanced, the gyroscopes finally remaining quiescent in their new position until some new disturbance is applied.

It remains to be said, however, that there is another element introduced when the car rounds a curve. To understand this, we must revert to the action of the Foucault gyrostat, as illustrated in diagram 1. If you held such a gyrostat in your hand in the upright position in which it is shown in the diagram, and whirled it about, the axis OA would of course maintain a fixed direction so long as the gyrostat was free to revolve on the axis DE . But if you prevented such revolution, as by clutching the spindle E firmly, and then whirled the gyrostat about at arm's length, the axis OA would at once be forced to take an upright position. If your hand whirled to the right, the point A would rise; if your hand whirled to the left, the point A would go down; the principle determining this motion in either case being that the direction of whirl of the gyroscope must correspond to the direction of curve given to the apparatus as a whole by the motion of your arm.

Exactly the same principle applies to the Brennan gyroscope when the car to which it is attached goes about a curve. The frame pivoted at DE revolves only within a limited arc, and then becomes fixed, and so the axis OF tends to tip upward when the car rounds a curve. If only a single gyroscope were used, this would tend to make the car tip in opposite directions, according to whether the car is going forward or backward, and the tip might be dangerous in going about a curve, as Mr. Brennan found to his cost in his earlier experiments. But when the two gyroscopes, revolving in opposite directions, are linked together, the action of one balances that of the other, and their joint effect is always to make the car lean in at a curve, which is precisely what it should do to ensure safety. Moreover, the two linked gyroscopes keep their planes of revolution parallel to the rail, as is essential to their proper action, and as a single gyroscope would not do.

The balancing action of the gyroscope seems no whit less remarkable after it is explained. It should be said, however, that the force exerted by the mechanism is not so tremendous as might at first thought appear, for the gyroscopes are by no means called upon to counteract the entire force of gravity brought to bear on the car. They do not in any sense *lift* the car; they only balance its two sides, which when left to themselves are approximately of equal weight. The car, as a whole, weighs down on the track just as heavily with the gyroscopes in action as when they are still. Balancing is a very different feat from lifting, as everyone is aware from personal experience. Two men pushing against the opposite sides of a monorail car could keep it balanced on the central rail though its weight vastly exceeded anything they could lift.

THE EVOLUTION OF AN IDEA

It goes without saying that so elaborate a mechanism as Mr. Brennan's gyroscope was not perfected in a day. Neither was it hit upon by accident. It belongs in the category of inventions that were thought out to meet a mechanical need. Mr. Brennan is an Irishman by birth, but he was taken by his parents to Australia at the age of nine and remained there throughout the years of his early manhood. Observation of the condition of the roads in Australia, and of the enormous retardation of development due to inadequate transportation facilities led him to ponder over the possibilities of improvement in this direction, as he was jolted about the country in a coach with leather straps in lieu of springs. It became clear to him that a way must be found to build railroads more cheaply. Furthermore, it was brought to his attention through observation of the condition of the cattle that were shipped from North Australia across the continent, that a railway car that would enable the cattle to make the journey in comfort, and thus arrive in marketable condition, would have enormous value for this purpose alone.

For years, Mr. Brennan tells me, the problem haunted him, of how to make a monorail car balance itself. He studied the action of rope-walkers, and he attempted various crude methods of balancing a car, which all came to nothing. He thought about the possibility of using the gyroscope, and even purchased several elaborate gyrostats in order to study gyroscopic action. As a friend of Sir Henry Bessemer, he knew of that gentleman's experiments with the gyroscope in attempting to make a steady room in a ship, but these also availed him nothing. It was not until

he purchased the toy top at Cannes, as already mentioned, that he got hold of a really viable idea; and then, of course, almost numberless experiments were necessary before an apparatus was devised that could meet all the requirements.

At last, however, a model car, more than fulfilling all his fondest hopes, was in actual operation. It remained to build a car of commercial size. To aid him in thus completing his experiments, Mr. Brennan received a grant of \$30,000 from the India Society. He believed that a car one hundred feet long and sixteen feet wide would be balanced by gyroscopes three and a half feet in diameter, so effectively that it would stand erect and rigid though fifty passengers were clustered on one side of its spacious room.

The accuracy of this prediction was put to the test in November, 1909, when Mr. Brennan exhibited the first gyrocar of commercial size. The result was demonstrative and convincing. The large car, carrying forty or fifty passengers, operated exactly as its inventor had foretold, and the doubts of the most skeptical were set at rest. Photographs of the car in actual operation, with its load of passengers, were sent broadcast, and it became apparent that the introduction of the gyrocar in competition with railway, trolley, and motor cars of the old type would be only a matter of time.

When we come thus to consider the gyrocar as a vehicle in which all of us may soon have an opportunity to ride, there is one practical question that is sure to present itself to the mind of almost every reader. What will be the effect should the electrical power that drives the gyroscopes give out at a critical moment, as, for instance, when the car is just crossing a gorge or river on a cable? Mr. Brennan's ingenuity has anticipated this emergency. The gyroscopes that balance his cars operate in a vacuum, and all the bearings are so well devised as to give very little friction. The wheels will continue running for a considerable time after the power is shut off. The large gyroscopes of the commercial car, it is estimated, will perhaps require two hours to attain the highest rate of rotation, but they will then continue revolving at an effective speed for some hours, even if no further power is applied to them.

It may be said, too, that the gyrocar is provided with lateral legs that may be let down in case of emergency or when the car is not in use, to avoid waste of energy in needless running of the gyroscope. All in all, it would appear that the dangers of travel in a gyrocar should be fewer than those that attend an ordinary double-track car; and Mr. Brennan believes that it will be possible, with the aid of the new mechanism, to attain a speed of one hundred and fifty, perhaps even two hundred miles an hour with safety.

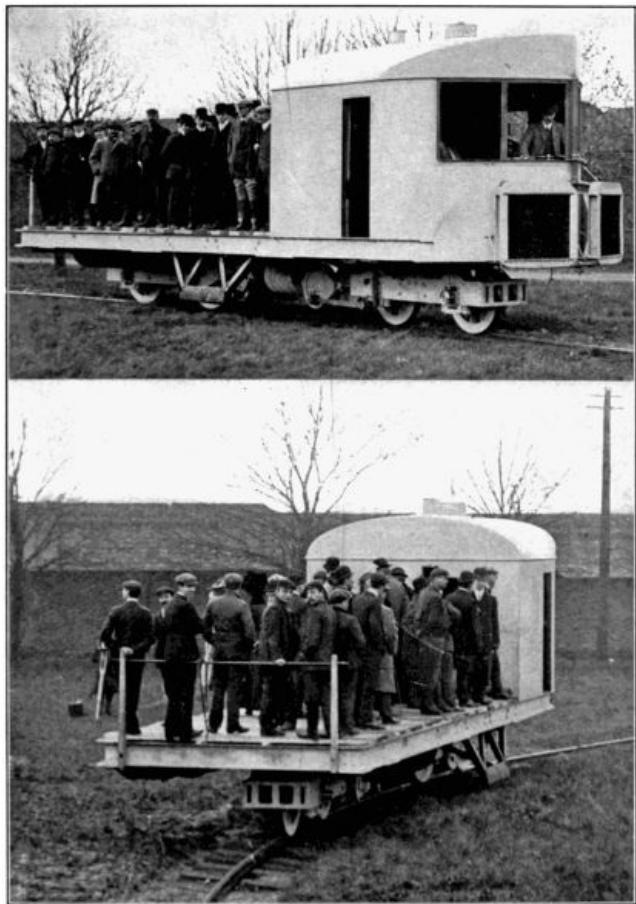

TWO VIEWS OF MR. LOUIS BRENNAN'S MONO-RAIL GYRO-CAR.

The gyroscopic mechanism for automatically balancing the car is contained in the cab-like anterior portion. The platform of the car maintains its equilibrium even when the forty passengers are crowded on one side, as shown in the upper picture.

THE GYROSCOPE AND OCEAN TRAVEL

IT must not be supposed that Mr. Louis Brennan's remarkable monorail car affords the first illustration of an attempt to make practical use of the principles of gyroscopic action. The fact is quite otherwise. The idea of giving steadiness to such instruments as telescopes and compasses on shipboard with the aid of gyroscopes originated half a century ago, and was put into fairly successful operation by Professor Piazzi Smyth (in 1856). More than a century earlier than that (in 1744), an effort was made to aid the navigator, by the use of a spinning-top with a polished upper surface, to give an artificial horizon at sea, that observations might be made when the actual horizon was hidden by clouds or fog. The inventor himself, Serson by name, was sent out by the British Admiralty to test the apparatus, and was lost in the wreck of the ship *Victory*. His top seemed not to have commended itself to his compatriots, but it has been in use more or less ever since, particularly among French navigators.

BESSEMER'S COSTLY EXPERIMENT

These first attempts to use the gyroscope at sea were of a technical character, and could have no great popular interest. But about twenty-five years ago an attempt was made to utilize the principle of the spinning-top in a way that would directly concern the personal comfort of a large number of voyagers. It was nothing less than the effort to give stability to a room on a steamship, in order that the fortunate occupant might avoid the evils of seasickness. The man who stood sponsor for the idea, and who expended sums variously estimated at from fifty thousand to more than a million dollars in the futile attempt to carry it into execution, was the famous Sir Henry Bessemer, famed for his revolutionary innovations in the steel industry. It would appear that Bessemer's first intention was to make a movable room to be balanced by mechanisms worked by hand. But after his project was under way his attention was called to the possibility of utilizing gyroscopic forces to the same end. As the story goes, he chanced to purchase a top for sixpence, and that small beginning led him ultimately to expend more than a million dollars in playing with larger tops. His expensive toy passed into history as the "Bessemer chamber." It was actually constructed on a Channel steamer; but the would-be inventor, practical engineer though he was, did not find a way properly to apply the principle, and his experiment ended in utter failure.

With this, the idea that the gyroscope-wheel could ever aid in steadying a ship at sea seemed to be proved a mere vagary unworthy the attention of engineers. But not all experimenters were disheartened, and since the day of Sir Henry Bessemer's fiasco a number of workers have given thought to the problem—with the object, however, of applying the powers of the revolving wheel not merely to a single room but to an entire ship. I have personal knowledge of at least one inventor, quite unknown to fame, who believed that he had solved the problem, but who died before he could put his invention to a practical test. It remained for a German engineer, Dr. Otto Schlick, to put before the world, first as a theory and then as a demonstration, the practical utility of the revolving wheel in preventing a ship from rolling.

DR. SCHLICK'S SUCCESSFUL EXPERIMENT

In the year 1904 Dr. Schlick elaborated his theory before the Society of Naval Architects in London. His paper aroused much interest in technical circles, but most of his hearers believed that it represented a theory that would never be made a tangible reality. Fortunately, however, Dr. Schlick was enabled to make a practical test, by constructing a wheel and installing it on a small ship—a torpedo-boat called the *Sea-bar*, discarded from the German navy. The vessel is one hundred and sixteen feet in length and of a little over fifty-six tons' displacement. The device employed consists of a fly-wheel one meter in diameter, weighing just over eleven hundred pounds and operated by a turbine mechanism capable of giving it a maximum velocity of sixteen hundred revolutions per minute. This powerful fly-wheel was installed in the hull of the *Sea-bar* on a vertical axis, whereas the Brennan gyroscope operates on a horizontal axis. So installed, the Schlick gyroscope does not interfere in the least with the steering or with the ordinary progression of the ship. Its sole design is to prevent the ship from rolling.

The expectations of its inventor were fully realized. On a certain day in July, 1906, with a sea so rough that the ship rolled through an arc of thirty degrees, when the balance-wheel was not in revolution, the arc of rolling was reduced to one degree when the great top was set spinning and its secondary bearings released. In other words, it practically abolished the rolling motion of the craft, causing its decks to remain substantially level, while the ship as a whole heaved up and down with the waves. These remarkable results, with more in kind, were recorded in the paper which Sir William White read before the Institution of Naval Architects in London in April, 1907. He himself had witnessed tests of the Schlick gyroscope, and, in common with his colleagues, he accepted the demonstrations as unequivocal.

Fully to understand the action of Dr. Schlick's invention, one must know that it is not a mere wheel on the single pivot, but a wheel adjusted in such a fashion that it can oscillate

longitudinally while revolving on its vertical axis. In other words, it is precisely as if one of the two gyroscope-wheels used in the Brennan car (greatly enlarged) were so placed that its main axis was vertical, its secondary axis, or axis of oscillation, being horizontal and at right angles to the ship's length. Thus, while spinning on its vertical axis the body of the top is able to oscillate, pendulum-like, lengthwise of the ship.

In principle the action of this wheel is not different from that of an ordinary top on your table which wobbles to the right or to the left when you push its axis straight away from you. Yet to the untechnical observer it seems as if the Schlick gyroscope were a living thing, governed by almost human motives. If you apply a brake to prevent the longitudinal oscillations of the gyroscope, the effect, even though the fly-wheel still revolves at full speed, is precisely as if you pinioned the arms of a strong man, so that he saw the futility of resistance and made no struggle to free himself. Under such circumstances the gyroscope—though it continues to spin as hard as ever—has no effect whatever in preventing the rolling of the ship; it stands there, like the strong man bound, expressing its discontent with an angry groan.

221

But if you release the brake so that the entire mechanism is free to oscillate lengthwise of the ship, all is changed. It is as if you cut the cords that bound the strong man's arms. Instantly the mechanism springs into action. It will no longer allow itself to be swung with each roll of the ship; it will resist and prove which is master. Its mighty mass, pivoted on the lateral trunnions, lunges forward and backward with terrific force, as if it would tear loose from its bearings and dash the entire ship into pieces. It causes the ship to pitch a trifle fore and aft as it does so; but meantime its axis stands rigidly erect in the lateral plane, though the waves push against the sides of the ship as before. The decks of the vessel, that were tipping from side to side, so that loose objects slid from one rail to the other, are now held rigidly at a level, scarcely permitted to deviate to the extent of a violent tremor. The gyroscope has won the contest. To maintain its victory it must continue its backward and forward plunging; but from side to side its axis will not swerve.

222

DID GYROSCOPIC ACTION WRECK THE *VIPER*?

It was the failure to understand that a gyroscope-wheel, to work effectively, must be given opportunity to oscillate in this secondary fashion that led Sir Henry Bessemer to spend an enormous sum in a vain effort to accomplish on a small scale what Dr. Schlick's gyroscope accomplishes for the entire ship. Now it is clearly understood that a marine gyroscope on an absolutely fixed shaft cannot exercise its full action; but there is still a good deal of difference of opinion among engineers as to just how much a spinning body must be permitted to oscillate in order to make its gyroscopic effects noticeable. The discussion that has taken place over the loss of the torpedo-boat *Viper* furnishes a case in point.

Some critics contend that the loss of the boat was due to the gyroscopic action of its turbine engines. They believed that the turbine at the stern of the little ship held that portion of the craft in a rigid plane, while the anterior portion of the ship, caught in the trough of a wave, broke away. That the ship broke in two is certain; but competent engineers have denied that gyroscopic turbines could have had any share in its destruction. According to their view, the turbines of a ship are powerless to exert the gyroscopic action in question, because their axes are fixed and they thus have not the opportunity for secondary oscillation to which I have referred. Meanwhile there are other equally competent mechanics who believe that the vibration or oscillation of the body of the ship itself may suffice, under certain circumstances, to give the turbine precisely such freedom of motion as will enable it to exercise a powerful gyroscopic effect. Dr. Schlick himself contends, and seems with the aid of models to demonstrate, that such a gyroscopic action is exercised by the wheels of a side-wheel steamer, which revolve on a shaft no less fixed than that of a turbine. If such is the case, there would seem to be no reason why a turbine-engine may not at times exercise the power of a tremendous gyroscope, such as it obviously constitutes. The question must find practical solution at the hands of the naval architects of the immediate future, as turbine engines are now in use in several of the largest steamships afloat, and others are being installed in craft of all descriptions.

223

THEORETICAL DANGERS OF THE GYROSCOPE

It should be said that engineers disagree as to the practical utility of the Schlick gyroscope. No one questions that it steadies the ship, but some critics think that its use may not be unattended with danger. It has been suggested that under certain circumstances—for example, the sudden disturbance of equilibrium due to a tremendous wave—the gyroscope might increase the oscillation of the ship to a dangerous extent, though ordinarily having the opposite effect.

The danger from this source is probably remote. There is, however, another danger that cannot be overlooked, and which marine architects must take into constant account. What we have already seen has made it clear that the revolving wheel of the Schlick gyroscope, to be effective, must bear an appreciable relation to the mass of the entire ship. Such a weight, revolving at a terrific speed and oscillating like a tremendous pendulum, obviously represents an enormous store of energy. It was estimated by Professor Lambert that a gyroscope of sufficient size to render even a Channel steamer stable would represent energy equal to fifty thousand foot-pounds—making it comparable, therefore, to an enormous projectile. Should such a gyroscope in

224

action break loose from its trunnions, it would go through the ship with all the devastating effect of a monster cannon ball.

The possibility of such a catastrophe is perhaps the one thing that will cause naval architects to go slowly in the adoption of the new device. We can hardly suppose that the difficulties represented are insuperable, but undoubtedly a long series of experiments will be necessary before the Schlick gyroscope will come into general use. The apparatus has been tested, however, on a German coast steamer. It may not be very long before craft of the size of Channel steamers and boats that go to Cuba and the Bermudas are equipped with the device. Naturally enough, this prospect excites the liveliest popular interest. Visions of pleasant ocean voyages come before the mind's eye of many a voyager who hitherto has dreaded the sea.

But whatever the future of the gyroscope as applied to pleasure-craft, there can be little doubt about its utility as applied to vessels of war. It seems a safe enough prediction that all battle-ships will be supplied with this mechanism in the not distant future. Amid the maze of engines of destruction on war-vessels, one more will not appal the builder; while the advantage of being able to fling a storm of projectiles from a stable deck must be inestimable.

225

226

NAVIGATING THE AIR

IF it were possible to regard all medieval literature without more than a grain of doubt, we must believe that aerial flight by human beings was accomplished long before science had risen even to the dignity of acquiring its name. Thus, it is recorded by a medieval historian that during the reign of Charlemagne some mysterious persons having acquired some knowledge of aerostatics from the astrologers, who were credited with numerous supernatural powers, constructed a flying-machine, and compelling a few peasants to enter it, sent them off on an aerial voyage. Unfortunately for the unwilling voyagers, so the story runs, they landed in the city of Lyons, where they were immediately seized and condemned to death as sorcerers. But the wise bishop of the city, doubting the story of their aerial journey, pardoned them and allowed them to escape.

That such a fabulous tale could gain credence is explained by the prevailing belief in the powers of the astrologers and sorcerers at that time. People who could seriously believe that an alchemist could create gold and prolong life and youth indefinitely, would find nothing startling in the announcement that he could also perform the relatively simple feat of flying—a thing that birds and bats accomplish with such obvious facility. And nothing is more certain than that attempts at aerial flight have been made at various times since the beginning of history. 227

As with almost everything else in the matter of modern scientific advancement, the mysterious writings of the monk, Roger Bacon, are supposed to contain passages to show that the worthy friar had an inkling of the secret of air navigation. But he himself admits that he had only a theoretical knowledge of the subject, and had never seen a flying-machine of any kind in actual flight.

Much more definite and tangible are the designs of possible flying-machines still extant in the sketch-book of Leonardo da Vinci, made in the fifteenth century. From Leonardo's sketches it appears that the artist had conceived the idea of constructing jointed wings to be worked with strings and pulleys, the motive power to be that of a man's arms and legs. It appears also that later he had very definite ideas as to the possibilities of an aerial screw, and he is believed to have constructed one of these screws made on the same general plan as that of the ordinary type of windmill in use at that time. But nothing of practical importance came of any of Leonardo's experiments.

It is probable that his abandonment of the project of flying by means of wings worked by muscular force was due to the discovery that the strength of the muscles of even the strongest man was relatively slight as compared with the corresponding muscle of birds. Leonardo was peculiarly capable of discerning this discrepancy in strength, since he himself was one of the strongest men of his time. It is said that he could bend and straighten horseshoes with his hands. But in his experiments with the aerial screw he probably discovered very soon that even such muscular force as he was capable of exerting was entirely inadequate; and there being no other mode of producing power at that time, the idea of aerial navigation by this means was also abandoned. 228

About this time some imaginative persons, realizing the possibilities of muscular development when begun in childhood and persistently practiced, attempted the development of a race of men whose abnormally strong pectoral muscles would enable them to use artificial wings for flying. For this purpose a certain number of young boys were selected and constantly drilled in exercises of flapping the arms, to which broad sails were attached. These attempts were persisted in for several years, and it is said that some of these boys became so expert that by skipping along the surface of the ground and vigorously flapping their wing-attachments, they could travel at incredible speed, although never able actually to rise from the ground.

In 1678, a Frenchman named Besnier invented a flying-machine that is credited with being more successful than any hitherto attempted. His machine consisted of two bars of wood which were so hinged to a man's shoulders that they could be worked up and down by movements of the hands and feet. At the ends of these two bars were muslin wings made like shutters, so arranged that they were opened by a downward stroke and closed automatically by a reverse motion. The general appearance presented by these wings was that of four book-covers fastened by their backs to the ends of the bars, opening and closing alternately as the bars were worked up and down. 229

The inventor began his experiments in a modest way. His first attempt at flight was by jumping from a chair; next he tried a table; and finally, emboldened by his success, he made flights from window-sills and even house-tops. On one occasion he is said to have sailed from his attic window over the roof of a neighboring cottage, alighting, without injury, some distance beyond. It was even rumored at one time that he would try to fly across the Seine, but if such a feat was ever contemplated, it was never attempted.

Half a century later, however, the Marquis de Bacqueville actually made such an attempt with a machine somewhat similar to that of Besnier. The marquis had practiced in private with his machine with such encouraging results that he felt confident the feat was not an impossible one—in fact, that he was sure of accomplishing it. He therefore announced publicly that at a certain time the attempt would be made, and on the appointed day an immense crowd of people gathered on the banks of the river to witness the spectacle. Starting from a building some little distance

away from the stream, the marquis made good progress at first, but just as he reached the river-bank his machine collapsed and he was tumbled out, alighting on a barge moored at the edge of the stream. Fortunately, the only injury he sustained was a broken leg; but this single attempt seems to have satisfied his aeronautic ambitions.

Until this time all attempts made at aerial flight had been those in imitation of birds; but during the early part of the eighteenth century the idea of the balloon was developed. This was the result of the numerous important discoveries made about that time as to the qualities of the atmosphere, and also several other "airs," as gases were called, such as their expansion and contraction under different conditions of temperature.

In 1766 the English philosopher, Henry Cavendish, discovered that hydrogen gas has only about one-seventh the weight of an equal bulk of air, this scientific discovery pointing naturally to balloon construction, since obviously if such a light gas were confined in a suitable receptacle, the device would rise to a certain height through the heavier atmosphere, as a cork rises through water. At the same time the experiments of the chemist, Dr. Joseph Black, and those of his younger contemporary, Doctor Priestly, were directed along the same lines, all of them pointing to the possibility of constructing an aerostat with buoyancy and lifting-power, and Priestly's *Experiments Relating to the Different Kinds of Air* is said to have been directly responsible for stimulating the efforts of Stephen and Joseph Montgolfier, the French paper manufacturers, who finally invented and sent up the first balloon.

Even before Montgolfier's invention, Tiberius Cavallo, an Italian living in England, had demonstrated the possibility of making toy-balloons. But the balloons of Cavallo were small affairs made of bladders or paper bags filled with hydrogen gas. One of these materials being too heavy and the other too porous for successful balloon construction, the performances of these toy-balloons were not conclusively demonstrative.

THE BALLOON INVENTED

Throughout the entire spring of 1783, all Auvergne, in France, was kept in breathless expectancy by constant rumors that the two Montgolfiers had really solved the problem of aerial flight, and would soon be seen soaring over the country in a strange birdlike machine. Rumor pictured this machine in various forms and sizes, but in point of fact there was really very little secrecy on the part of the inventors themselves, who frankly explained the principle of the balloon they were constructing. It was hardly to be expected, however, that most persons would believe the plain truth that so simple a device as a bag filled with hot air would do what had long been considered impossible.

Spring advanced and lapsed into summer, however, and as no flying-machine made its appearance, public clamor became so loud that the Montgolfiers felt they could postpone their demonstration no longer, although the balloon they were working on was not completed to their entire satisfaction. Nevertheless, they fixed on the definite date of June 5, (1783) as the day and Annonay as the place for making the trial, and their faith in their invention was shown by the fact that special invitations were sent to the leading persons in the vicinity, and a general invitation extended to the world at large.

But in place of some complicated and birdlike machine, as rumor had pictured the flying-machine, the multitude that gathered about the starting-point found only an immense cloth bag about thirty-five feet in diameter, without machinery or wings, and capable of containing some twenty-two thousand cubic feet of air, which the Montgolfier brothers and their assistants were inflating with heated air. As the bag filled, one of the brothers announced with all seriousness, that as soon as it was completely filled it would "rise to the clouds," carrying with it a frame weighing some three hundred pounds.

This announcement was not received with the same seriousness with which it was given. The idea of expecting anyone to believe that an ordinary cloth bag would fly excited the risibilities even of the more serious members of the crowd. Nevertheless, as the great globe filled it became evident to the spectators that it was tugging at the restraining ropes in efforts to rise, in a most extraordinary manner; and when, at a signal from the inventors, the ropes were cast off and the monster shot skyward, the crowd's smiles were turned to expressions of gaping astonishment. Straight into the air the monster mounted, and then, wafted by a gentle breeze, it continued to soar and rise until in ten minutes it had reached an altitude of six thousand feet, sailing easily in a horizontal direction for a short distance, then gradually descending and alighting some eight thousand feet from the starting-point.

The news of this triumph travelled quickly to Paris, and the Parisians clamored to see the wonderful performance repeated in the capital. The king and court were as interested as the savants and the populace, and an order was sent at once by his Majesty, bidding the brothers bring their balloon to the city.

In the meantime, however, a savant named Charles had started the construction of a balloon that was to be filled with hydrogen gas instead of heated air. This was a much more expensive undertaking, as a thousand pounds of iron filings and five hundred pounds of sulphuric acid were necessary to manufacture a sufficient quantity of gas to fill the varnished silk bag. But by the 23rd of August everything was in readiness for the filling process, and the following day this first gas-balloon rose from the Champs de Mars to a distance of three thousand feet and disappeared into the clouds. Three-quarters of an hour later it descended in a field near the little village of

Gonesse, to the great consternation of the inhabitants of the neighborhood, who supposed it to be some monster bird, animal, or flying dragon. Arming themselves with scythes and pitchforks, therefore, but keeping at a safe distance, the boldest of the peasants sallied out and surrounded the field in which the creature had alighted. As it made no offensive movement, however, one bold huntsman armed with his trusty fowling-piece, crept cautiously within range and fired, tearing a hole in the monster's side and causing it to writhe and collapse, giving off what appeared to be a foul-smelling, poisonous gas in its death-struggles. When finally it lay flat and still the villagers became emboldened, and rushing upon it cut and tore it to shreds, ending the performance by tying the fragments to a horse's tail and sending the animal scurrying across the fields.

In anticipation of some such demonstration as this, the French Government had sent out a proclamation on the day of the ascent. "Anyone who should see in the sky a globe, resembling the moon in an eclipse," the proclamation ran, "should be aware that far from being an alarming phenomenon, it is only a machine, made of taffeta, or light canvas covered with paper, that cannot possibly cause any harm, and will some day prove serviceable to the wants of society." But apparently none of the villagers of Gonesse had seen this proclamation. 234

The success of these balloon ascensions sent a wave of enthusiastic interest in aeronautics all over France. The novelty and possibilities of ballooning appealed to the French temperament, just as the possibilities of submarine navigation and automobiling did a century later. As a result, France became at once the centre of ballooning, the whole nation being eagerly absorbed in the subject of navigating the air. In the theatre of action, the Montgolfiers continued to occupy the centre of the stage, and at all times showed themselves worthy of the leading rôle. Pursuant to the order of the king, M. Montgolfier had come to the capital, and on September 19th, before Louis XVI and his queen and the court at Versailles, sent up another hot-air balloon, or "Montgolfier," as this kind of balloon had come to be called.

A novel and important feature of this exhibition, however, was the substitution of living animals for sand-bags or other ballast, as used heretofore. In a wicker cage a cock, a duck, and a sheep were fastened, and these were carried some fifteen hundred feet into the air, descending uninjured, two miles from the starting-point, a few minutes later. The cage was broken open in the descent, but its occupants escaped injury, and the sheep was found quietly grazing when the rescue party arrived. 235

The successful voyage of these caged animals stimulated the balloonists to attempt the crucial test of sending up a balloon carrying a human passenger. But from this perilous undertaking the boldest spirits recoiled, even the Montgolfiers refusing to venture. In those days, however, there was always a means of securing human beings, willing or otherwise, for any undertaking. Where gold would not tempt, it needed but a word of the monarch to commute the death-sentence of some criminal, placing him at the disposal of the scientists for a better or worse fate than the gallows, as the case might be. And so when Louis XVI heard of the plight of the balloon-makers, he came to their assistance with the offer of two condemned prisoners to be sent on the first aerial voyage. This offer had an unexpected effect. The pride of a certain high-minded aeronaut named Rozier, who had hitherto refused to risk his life, was touched at the thought of criminals performing an act that all honest men refused. "What! are vile criminals to have the glory of being the first to ascend into the air?" he exclaimed. "No, no, that must not be." And forthwith he offered his own services for the hazardous undertaking.

The royal decree was accordingly repealed, to the chagrin of the criminals, no doubt, and preparations made for the momentous attempt. Montgolfier was engaged to construct a large balloon, and on the 15th of October, 1783, the trial was made in a garden in the Faubourg St. Antoine. Let no one suppose, however, that this first man-carrying balloon was cut loose from the earth and sent skyward to shift for itself, as might be gathered from the reluctance of persons to make the ascent. On the contrary, the balloon was held by strong cables, and allowed to rise only to a height of eighty feet—to the level of some of the lower windows of a modern sky-scraper—the aeronaut keeping it afloat for about five minutes by burning wool and straw in a grate made for the purpose. 236

Those who have witnessed the reckless manner in which the modern balloonist mounts thousands of feet into the air, seated on a trapeze or clinging to flying rings attached to an old balloon, patched and frequently rotten, may be inclined to sneer at the brave Rozier. But it should be remembered that in 1783 people had not learned nineteenth-century contempt for altitude. Furthermore, no one could tell what might be the effect upon the human system of ascending to a great height when away from a building or other terrestrial object. Fainting, hemorrhages, heart-failure, and death had been predicted, and could not be practically refuted. In short, it was an absolutely new and untried field; and it required far greater courage on the part of Rozier to mount eighty feet in a captive balloon than for a modern aeronaut to sail thousands of feet skyward. In proof of this is Rozier's subsequent record of ascents in free balloons, and dangerous voyages, in the last of which he lost his life.

To France, therefore, belongs the honor of inventing the balloon and being first to test it with a human passenger. On this last point, however, France only eclipsed America by a few days. For while the craze for balloon-making was at its height in France during the summer of 1783, a somewhat similar craze on a small scale had started in some of the American cities. Two members of the Philosophical Academy of Philadelphia, Rittenhouse and Hopkins, constructed a peculiar balloon having forty-seven small bags inflated with hydrogen attached to a car. On November 28th, six weeks after Rozier's ascent, this balloon was sent up, with James Wilcox, a carpenter of Philadelphia, as passenger. Everything was going well with the voyager until he 237

suddenly discovered that the wind was wafting him toward the Schuylkill River, which so alarmed him that in attempting to descend quickly he punctured the bags so freely that he came to the ground with considerable force, escaping, however, with a dislocated wrist.

Meanwhile, in Europe, a new danger to balloonists had arisen. Fanaticism was rife, particularly in the vicinity of Paris, and many members of the cloth were tireless in denouncing this "tampering with God's laws by invading the inviolability of the firmament." Fortunately, the king took a broader view, and his soldiers were supplied freely for protecting balloonists and their property; but even with this protection both were roughly handled at times.

By this time England had become aroused; balloon-making became popular across the Channel, and some new records for time and distance were soon made. One balloon sent up in London landed in Sussex, forty-eight miles away, making the voyage in two hours and a half. A few days later a small balloon sent up in Kent was blown across the Channel and landed in Flanders. But neither of these balloons carried passengers.

238

As yet there had been few serious attempts at constructing dirigible balloons, but now Jean-Pierre Blanchard opened a new era of experiments by combining an ordinary balloon for obtaining the lifting power with wings and rudder. In this balloon there was also placed an umbrella-shaped sail interposed horizontally between the car and the body of the balloon, which was to act as a sort of parachute in case of accident. On the first voyage in this balloon Blanchard was to have had for companion a Benedictine monk; but as the machine began to rise from the ground the monk was seized with fear, turned deadly pale, crossed himself, and seemed about to collapse. Fortunately at this moment a leak was discovered in the balloon and it was accordingly lowered for repairs. When these were completed the aeronaut decided to dispense with the company of the monk, who was only too willing to gratify his wish. But just as the car was again ready to start, a stripling student from the Military Academy forced his way through the crowd, jumped into the car, and announced his intention of making the ascent. Being ordered from the car by Blanchard, he declared that he had the king's license, and when asked to produce it he drew his sword, declaring that this was the license he referred to. By this time the crowd had lost patience; some one seized the young man unceremoniously by the collar, hauled him from the car, and turned him over to the police.

239

A few years later particular attention was called to this incident by a rumor, which finally grew into a fixed belief in France, that the young military student in question was none other than the youthful Napoleon Bonaparte, then a student at the Academy. Throughout the entire reign of the emperor this was the general belief, and if it was denied at all by Napoleon, the denial was not made with due emphasis. At St. Helena, however, the captive emperor finally stated definitely that he was not the hero of this escapade, who is now known to have been a student by the name of Chambon.

Nothing of importance came of Blanchard's first attempt at guiding a balloon with rudder and wings, except perhaps to emphasize the fact that wings of an oarlike type were useless for propulsion; but nevertheless Blanchard soon prepared a somewhat similar balloon in which he proposed to steer himself across the English Channel. Before this time, as will be remembered, several balloons had crossed the Channel, but none of them had carried passengers. On this voyage Blanchard proposed to make the attempt, taking with him as companion an American physician named Jeffries. On January 7, 1785, these two embarked from the cliffs of Dover, a strong wind at the time setting toward the French coast. Before their journey was half completed they discovered that an insufficient amount of ballast had been shipped, and that the balloon was gradually descending at a rate which would land them in the Channel several miles from shore. To avert this calamity they were obliged to throw out everything in the car—books, provisions, anchors, ropes, the "wings" that were intended for guiding, and also most of their garments. They were, indeed, about to cut loose the car itself, and climb into the shrouds, when suddenly the balloon, caught by a fresh current of air, began to rise, and was wafted to a safe landing place. This was the most daring exploit as yet performed by the aeronauts.

240

Although at least fifty different persons had made more or less extended aerial voyages during the two years that had intervened since the invention of the first balloon, no one of them had been seriously injured. Indeed, this apparently most dangerous undertaking had been relegated to the grade of commonplace in popular opinion, owing to these fortunate results. But the world was soon to learn that its first estimates of the dangers of ballooning had not been exaggerated.

Since the invention of the Montgolfier balloon two distinct schools of balloonists had arisen, one of which favored the hot-air, and the other the hydrogen balloon. By the advocates of the hot-air balloon it was claimed that the relatively small expense, and the fact that the balloonist could descend at any time and renew his supply of fuel, made this the most desirable type, at least for long-distance voyages. By the advocates of the hydrogen balloon it was shown that the hot-air balloon must be constructed much larger to obtain the same amount of lifting power, could be maintained in the air for a comparatively short time at most, and was in constant danger from the fire that must be kept burning in the grate. In reply to this last charge the hot-air advocates pointed out that a tiny spark of electricity, which would not affect the hot-air balloon, might explode the hydrogen balloon, thus introducing an element of danger quite as great as that of the fire in the hot-air balloons.

241

As an outcome of these disputes, Pilatre de Rozier, the first man ever to make an ascent, proposed to attempt to cross the Channel in a new-type balloon, a combination of hot-air and hydrogen machine, which was supposed to represent the good qualities of both types. Several

months were consumed in constructing it, and when finally completed he and a companion attempted to cross the Channel, as had been done by Blanchard and Jeffries a short time previously. All went well at first and the balloon was several miles on its journey when suddenly the wind changed, the balloon was blown back over the heads of the anxious watchers below, and when a short distance inland, suddenly burst into flames. At first it descended with an oscillating movement, and then, freed from the restraining silk and canvas, it shot downward, striking the earth with terrible force, the two occupants being killed. Thus the man to make the first ascent in a balloon was also the first to lose his life. Rozier himself seems to have expected some such ending to his voyages, and just before making his last ascent he remarked to a friend that, whatever the outcome, "one had lived long enough when one had added something to humanity."

The fate of Rozier and his companion being known, and the awful dangers of balloon ascensions thus forcibly brought home, there was a popular outcry against such attempts and efforts were made to pass laws forbidding them. But no such demand or suggestion came from the balloonists themselves. They could point to the fact that, while as yet the balloon had been of no importance commercially, it had at least been turned to some account in the field of science, which was simply a stepping-stone to commercial advancement. It had been the means of settling forever the question of temperature and rarefaction at different altitudes, besides numerous less important although no less interesting subjects.

While it was true that many of the experiments of the aeronauts had added largely to human knowledge, some of them were both dangerous and foolhardy. An exhibition of this kind of folly was given by the Frenchman, Testu-Bressy, who, wishing to test his theory that large animals would bleed from the nose at a much lower elevation than man, despite the thicker consistency of their blood, made an ascent mounted on the back of a horse. On this occasion the aeronaut did not, even take the simple precaution of tying the horse's feet to the car; and what seems most remarkable, the animal made the journey without moving or showing any sign of fear.

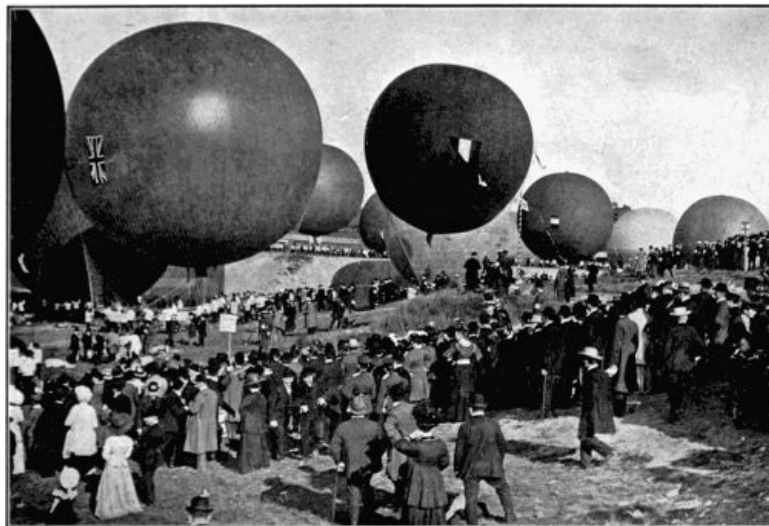

AN INTERNATIONAL BALLOON RACE.

This view was taken before the start of an international balloon race near Berlin. The balloons are of the ordinary non-dirigible type.

The time was at hand, however, when Montgolfier, who had always maintained that the true usefulness of the balloon would be in warfare, was given the opportunity of seeing his contention verified. On the breaking out of the French Revolution, balloon corps were at once pressed into the service of the army. Napoleon Bonaparte carried with him some balloons on his Egyptian campaign, partly for the purpose of making observations, and partly to impress the Arabs with the superiority of Christian armies. A school of aeronautics was established at Meudon, and some fifty young men, sworn to secrecy, assigned to it. Balloons were constructed, tested, and distributed among the different divisions of the army, and one of these was used for reconnoitering the position of the Austrian forces just before the battle of Fleurus. In the course of the day two ascents were made in this balloon, which was held captive by several thousand feet of cable. The second ascent drew the fire of the enemy's cannon, but the range was too great and no harm was done. Meanwhile the French general, Jourdain, was furnished most valuable information by these aerial voyages.

The Revolutionary wars were also responsible, indirectly, for the invention of the parachute. It will be recalled that even as early as the fifteenth century, Leonardo da Vinci had conceived the idea of a kind of parachute; and that Blanchard had a spread-canvas arrangement to produce a similar effect attached to some of his balloons. It was not until 1799, however, that the folding umbrella-like parachute was invented, the inventor, Garnerin, having developed the idea in trying to devise some means of escape from the fortress of Buda, Hungary, where he was being kept prisoner after one of the battles in the North between the Revolutionary forces and the Austrians and Prussians. Although he did not actually effect his escape in this dramatic manner, he finally proved that he had not dreamed in vain during his imprisonment by demonstrating the entire practicality of the parachute.

Garnerin's first practical test of his invention was made in October, 1797, when he ascended to the height of six thousand feet in a balloon to which was attached a parachute of the ordinary umbrella type still used. At that altitude he cut loose the balloon which rushed upward until it exploded, while the parachute, dropping rapidly at first, finally settled slowly and gently to the earth, without injury to the inventor.

PROGRESS IN MECHANICAL FLIGHT

The attempts at navigating a balloon having proved thus far so unsuccessful, many inventors now returned to the idea of producing a flying-machine which was independent of the inflated balloon. It was evident that the resistance presented by the great surface necessary in a balloon of sufficient size to have the required lifting power was such that no known efforts of propulsion could overcome this resistance even in the face of a slight breeze, to say nothing of a strong wind. The balloon was by no means abandoned, however, and two definite schools of aeronauts gradually came into existence, each having ardent advocates.

As early as 1784, the aeronaut Gérard had proposed a flying-machine which was to be made with body, wings, and steering apparatus, in which propulsion was to be accomplished by the use of escaping gas and gun-cotton. The inventor himself was so sanguine of the results, and so many contemporary inventors were of the same opinion, that when this machine proved to be an utter failure, the blow to the advocates of the flying-machine was so great that they did not rally from it for something like a quarter of a century. In 1809, however, a Viennese watchmaker named Degen revived interest in attempts at mechanical flight by inventing a flying-machine which consisted essentially of two parachutes. These were worked by hand, and the inventor was said to have been able to rise to a height of over fifty feet from the ground "moving in any desired direction."

245

These claims were not borne out in fact, but they stimulated an interest in the possibilities of mechanical flight, and in the parachute, which had never come into popular favor despite its successful use by the inventor, Garnerin. Hopes were again entertained that a modification of this device might be utilized in solving the problem of aerial flight, and in 1837 an aeronaut, Henry Cocking, invented a new type in which he proposed to descend from a balloon. The parachute of Garnerin, as we know, had been constructed like a huge umbrella, whereas Cocking's parachute had the general appearance of an umbrella held upside down. An unusual interest was aroused in the prospective experiment from the fact that a great majority of scientists did not consider that this parachute was constructed on correct scientific principles, and predicted that the aeronaut would be killed when he attempted to use it. Before the day of the trial arrived numerous articles had been published, presenting arguments for and against Cocking's device, and on the very day itself one of the newspapers contained a long article by a leading authority on aerostatics, reviewing the numerous reasons why the attempt would surely prove a failure.

Despite the protests of the majority of interested persons, however, Cocking and a companion named Green made the ascent at the appointed time. After rising to a certain height the parachute was cast off, the parachute's car containing the inventor, while Green remained in the balloon. Instead of sailing slowly toward the earth, however, the parachute fell rapidly, with an oscillating movement, gaining speed and jerking violently as it descended, until finally when several hundred feet in the air, Cocking was thrown from the car and dashed to pieces, while the wreck of the parachute landed a few yards away. Thus the predictions of the majority came true, although as we know now, the cause of the tragedy was due to faulty material rather than the design of the machine. For the American aeronaut, Wise, demonstrated a little later that parachutes built on the same principle as that of Cocking could be used successfully.

246

As we have seen, most of the flying-machines attempted heretofore took for their model the bird with flapping wings. There were certain persons, however, who had observed that this flapping movement was not essential to flight—that certain large-winged birds, such as buzzards and hawks, were able to soar in any direction at will, holding their wings rigidly. It was evident, therefore, that shape, position, and construction of the bird's wing played quite as important a part as the flapping movement. The lifting power of plane surfaces, or aeroplanes, was also carefully studied in this connection and in 1842 the inventor, Henson, constructed a flying-machine utilizing this aeroplane principle, his machine having thin, fixed surfaces, slightly inclined to the line of motion, and supported by the upward pressure of the air due to the forward movement.

247

Everyone will remember the distance to which a skilful juggler can project an ordinary playing-card by giving it a certain inclination in throwing. It will travel upward or on a level, and continue this direction until the force of the movement of throwing is exhausted. Obviously, if this force were self-contained in the card—if it could continue rotating and moving forward—it could fly indefinitely. Henson had studied and experimented with these miniature aeroplanes, and was convinced that if the same principle that governed their flight were to be applied to larger machines, practical flying-machines could be made.

"If any light and flat, or nearly flat, article," he wrote, "be projected edgeways in a slightly inclined position, the same will rise on the air till the force exerted is expended, when the article so thrown or projected will descend; and it will readily be conceived that if the article possessed in itself a continuous power or force equal to that used in throwing or projecting it, the article

would continue to ascend so long as the forward part of the surface was upward in respect to its hinder part, and that such article, when the power was stopped, or when the inclination was recovered, would descend by gravity only if the power was stopped, or by gravity, aided by the force of the power contained in the article, if the power be contained, thus imitating the flight of a bird."

But when Henson attempted to fly in his elaborately planned and constructed flying-machine, it proved a complete failure. It showed a tendency to rise, but its lifting power was insufficient for the weight of the engine driving the propellers. It was evident, however, that if the power of the engine could be sufficiently increased, or, what amounts to the same thing, its weight sufficiently lightened, a machine built on the aeroplane principle could be made to fly. But at that time the lightest type of engine was a crude, heavy machine, and for the moment nothing more was attempted in producing a mechanical flying-machine propelled by steam.

248

Meanwhile the possibility of producing a dirigible balloon was again brought into prominence by the suggestion of two aeronauts, Scott and Martainville, to change the shape of the envelope of the balloon. Hitherto, all balloons had been made globular or pear-shaped—shapes that offered great resisting surfaces to the atmosphere. Now it was proposed to make them in the form of long, horizontal cylinders, with pointed ends, these cigar-shaped, or boat-shaped balloons offering much less resistance. But here, as in the case of the flying-machine, engines that were sufficiently strong to work the propellers were found to be too heavy for the balloon to lift. Meanwhile the aeroplane idea was brought into prominence from an unexpected quarter.

Among the numerous observers in the middle of the century who had noted the soaring power of birds, was a French sea-captain named Le Bris. On his long voyages he had studied the movements of the great albatross, which, with wings rigidly distended, outsailed the swiftest ship without any apparent exertion. Anxious to study the wing-mechanism of this bird, the captain, overcoming the scruples of the mariner against killing the sacred sea-rover, shot one of the birds. On removing a wing and spreading it in the wind he thought that it had a very appreciable tendency to pull forward into the breeze, and tended to rise when the wind was strong. Convinced that by duplicating the shape of the bird he could construct a successful flying-machine, Le Bris set to work and succeeded in producing a most remarkable "air-ship."

249

The body of this machine, which was supposed to correspond to the body of the bird, was made boat-shaped, and was about thirteen feet long and four feet wide, being broadest at its prow, in imitation of the breast of the bird. The front part was decked over, something like the bow of the modern torpedo-boat, and through this deck protruded a small mast which was used for supporting the pulleys and cords used in working the machinery of the wings. Each wing was about twenty-five feet long, so that the entire spread of the machine was fifty feet. There was a tail-like structure so hinged that it could be used for steering up, down, and sidewise, the total area of surface presented to the atmosphere being something over two hundred square feet, although the entire "albatross" weighed something less than a hundred pounds.

The front edges of the wings were made of pieces of wood fashioned like the wings of the albatross, and feathers were imitated by a frame structure covered with canton flannel. The front edges of the wings could be given a rotary motion to fix them at any desired angle by an ingenious device worked by two levers. In operating this artificial bird the captain proposed to stand in the boat and control its flight by these sets of levers and by balancing his body.

250

Having full confidence in the ability of his invention to soar once it had been given an initial velocity, the captain selected a morning when a good breeze was blowing and hired a cart-driver to carry him out into the neighboring fields. The machine was placed horizontally upon the cart and fastened to it with a rope which could be loosened by the pulling of a slip-knot held by the captain, who took his position in the boat. On reaching the open country the driver put his horse into a brisk trot when, the levers controlling the wings being set, the machine rose gracefully into the air and travelled forward a distance of perhaps a hundred yards. At this moment the running-rope in some unaccountable manner became wound about the body of the driver, hauling him unceremoniously from his seat, and dangling him writhing and shrieking at the end of the rope, several feet above the ground. As it happened, his weight was just sufficient to counterbalance the wind, so that acting in the capacity of the tail of a kite, he assisted materially, if involuntarily, in keeping the artificial bird in flight.

When the captain became aware of what was going on below, he altered the angle of the wings and came slowly to the earth, descending without accident either to himself or to his machine. All things considered, this was a remarkable performance, and it was so considered by people in the neighborhood, who made a hero of the gallant mariner. His next attempt, however, was less successful. Something went wrong with the machine shortly after starting, landing the inventor in a stone-quarry with a broken leg and a shattered machine. This accident also shook the courage of the captain, and for several years he made no more attempts at flight, confining his attention to sailing a coasting-vessel. But his faith in his "albatross" never wavered, even if his courage did for a time, and in 1867 he began building a more elaborate machine, aided by public subscriptions. The outlook for this new device seemed very promising, several fairly successful flights of perhaps two hundred yards having been made, when a sudden gust of wind catching up the machine one day during the momentary absence of the inventor, dashed it to pieces upon the ground. This was the final blow to the hopes of Captain Le Bris, who made no further attempts, his means and his energies being entirely exhausted.

251

GIFFARD, "THE FULTON OF AERIAL NAVIGATION"

Meanwhile the advocates of the dirigible balloon had not remained idle, many of them attempting to utilize the principle of the aeroplane in connection with a balloon. Some of these machines were of most fantastic design, but one in particular, that of Mr. Henri Giffard, succeeded so well, and proved to be dirigible to such an extent, that Giffard is sometimes referred to by enthusiastic admirers as "the Fulton of aerial navigation." In principle, and indeed in general appearance, this balloon was not unlike some of the balloons built by Santos-Dumont fifty years later. It had the now-familiar cigar shape, common to most modern dirigible balloons; and beneath was suspended a car carrying a steam-engine that worked a screw propeller. The rudder, placed at the stern just below the balloon in a position corresponding to the rudder of a ship, was a large canvas sail set in a frame. The envelope of the balloon was one hundred and fifty feet long and forty feet in diameter and contained about ninety thousand cubic feet of coal-gas. To lessen the danger of igniting this from the engine, Giffard arranged the chimney so that it pointed downward, and suspended it some forty feet below the envelope. 252

On September 24, 1852, he rose from the Paris Hippodrome, and succeeded in making a headway of from five to seven miles an hour in the face of a strong wind. In response to the rudder his balloon performed some difficult evolutions, turning right or left at the will of the operator. He continued his maneuvers for some time, and then extinguishing his fire, opened the valve and returned safely to the ground. This was a great victory for the advocates of the dirigible balloon, and was indeed a performance that has not until recently been surpassed in the fifty years that have intervened since that time. But despite this initial success, Giffard soon renounced the field of aeronautics, and no worthy successor appeared to take his place for more than a quarter of a century.

THE VOYAGES OF THE *GIANT*

One of the most remarkable balloons ever constructed, and one of the most remarkable voyages ever made in any balloon, was that of the mammoth aerostat constructed by the noted Parisian photographer, Nadar, in 1863. Nadar belonged to the school of aviators who opposed the principle of the balloon as against that of the aeroplane, and his idea in constructing this leviathan balloon was simply for the purpose of raising money so that he might build a practical flying-machine, constructed on the aeroplane principle, and which, he declared, would revolutionize air navigation. The *Giant*, he said, would be the last balloon ever constructed, as thereafter air-ships, made on the principle of the one he was about to construct, would supplant balloons entirely. His plan was to make the ascent in the *Giant* from some large enclosed field near Paris, and the admission price of one franc to be charged for entering the field was to supply funds for defraying the expense of building the *Giant*, the surplus to be used in constructing his flying-machine. 253

In making the *Giant* twenty-one thousand yards of silk were used, the balloon being over two hundred feet in height, with a lifting capacity of nine thousand pounds. It was built as a double balloon, one within the other, this being the idea of the aeronaut, Louis Godard, as a means of preserving the excess of gas produced by dilation at different altitudes, instead of losing this excess as was usual with balloons constructed in the ordinary manner. But perhaps the most interesting thing about this balloon was the structure of the car and its contents. Like the ordinary car it was constructed of wicker work, but was of the proportions of a small house, being built two stories high, with an upper platform like the deck of a ship, on which the passengers could stand. In the two floors below were a saloon, compartments for scientific instruments, sleeping-cabins, and practically all the conveniences of a small, modern house. In the car and suspended about it were wheels, guns, a printing-press, cameras, cages of carrier-pigeons, baskets of wine and provisions, games, and an "abundant supply of confectionery." 254

The first ascent was made from the Champs de Mars, and twenty-five thousand persons paid the admission fee to witness it. This did not by any means represent the number of persons on the field, as the barriers were broken down in many places early in the day, and a majority of the spectators thus gained free admission. Fifteen persons made the ascent upon this occasion, but instead of making a protracted voyage as intended at first, the balloon was brought to the earth at nine o'clock in the evening only a few leagues from Paris. It is said that this landing was made contrary to the wishes of Nadar, but in deference to the opinion of the Godard brothers, who believed that the balloon was being carried out to sea, whereas, in point of fact it was travelling due east, directly away from the Atlantic.

Three weeks later the second ascent was made, on this occasion eight instead of fifteen persons starting on the voyage. These were under the immediate command of Nadar, whose position was that of the captain of a ship on the high seas, and whose authority none might presume to question. A set of rules governing the conduct of those on board and setting forth explicitly the authority of the captain was posted in the cabin, the nature of some of these giving a cue to the peculiar attitude of mind of the originator of the scheme. For example, it was ordered that "Silence must be absolutely observed when ordered by the captain." "All gambling is expressly prohibited." "On landing no passenger must quit the balloon without permission duly acquired from the captain." 255

The ascent was again successful, the balloon travelling in a northeasterly direction during the night, all the passengers remaining awake and alert, having constantly in mind the danger of

falling into the sea. The following morning on descending to a lower altitude through the clouds, the voyagers found that they were passing the border of Holland, near the sea. At this point an attempt was made to land, but a violent gale having arisen, the anchor cables were broken, and the car was dragged along the surface of the ground at terrific speed, striking and rebounding into the air, dragging through marshes and rivers, bruising and battering the occupants who were unable either to leave the balloon or to check its flight. As they were whirling across the country in this manner an immense forest came into view directly in their path, and believing that when this was reached every occupant of the car would be dashed to pieces against the trees, they decided to take their chances by leaping. One after another they jumped, striking the earth and turning over and over, breaking bones, and mangling faces and bodies. The only female occupant of the car, Mrs. Nadar, was fortunate in alighting in a river without serious injury. Others received only slight bruises or a severe jolting while the most unfortunate, M. St. Felix, had a broken arm, a dislocated ankle, and numerous cuts and bruises.

256

Later the *Giant* was captured many miles farther on and returned to its owners in Paris. Subsequently it made numerous voyages, none of which was particularly profitable, however, so that the purpose for which it was designed was not fulfilled, and Nadar's proposed air-ship was never constructed.

While the *Giant* was the largest balloon hitherto constructed, it broke no records either for speed attained or distance travelled, and much more notable performances in this respect had been made before its time and have been made since. Thus, one of Coxwell's balloons traveled from Berlin in the direction of Dantzic, covering the distance of one hundred and seventy miles in three hours. This was in 1849; and in the same year M. Arban crossed the Alps from Marseilles to Turin, covering the distance of four hundred miles in eight hours. In July, 1859, the American aeronaut, John Wise, sailed from St. Louis, Missouri, to Henderson, in New York State, in nineteen hours, travelling eight hundred and fifty miles at the rate of forty-six miles an hour. This was the longest voyage ever made until the time of the balloon-races started from the Paris Exposition, in 1900. On this occasion Conte de la Vaux, starting from Paris, remained in the air thirty-five hours and forty-five minutes, landing at Korosticheff, in Russia, 1193 miles from the starting-point, thus breaking all previous records.

257

EARLY WAR-BALLOONS AND DIRIGIBLE BALLOONS

Despite the fact that the "aviators"—the aeronauts whose efforts were directed to flight by mechanical means in imitation of birds, or by the use of what are now called aeroplanes—were in the field centuries before the balloon was invented, from the time of the first Montgolfier balloon until very recently, the balloonists had shown their rivals a clean pair of heels in practical results. A dirigible, man-carrying balloon that can be guided under favorable conditions, and can maintain itself in the air for any considerable length of time, was an accomplished fact at least five years before the practical aeroplane flying-machine. Yet the majority of scientists had become convinced several years before their convictions were verified by actual demonstration, that some type of mechanical flying-machine—a machine that is heavier than the atmosphere and that maintains itself by some mechanical means—was the only one likely to solve the question of aerial flight. Yet thus far balloons have rendered more actual service to man than flying-machines.

It will be recalled that balloons were used for making military observations during the French Revolution; and they were used for similar purposes in several of the Continental wars during the first half of the nineteenth century. After that time, however, interest in their use for this purpose flagged somewhat until the time of the Crimean War, when their usefulness was again demonstrated, as it was in the American Civil War which followed shortly after.

But it was not until the Franco-Prussian War that the one thing for which the Montgolfiers had predicted their usefulness in warfare—that of sending messages out from a closely besieged city—was put to practical test. During the siege of Paris by the Germans in 1870-71, when every other possible means of communication had been cut off, the Parisians still kept in communication with the outside world by means of balloons and carrier-pigeons. On September 23rd, the first ascent of the siege was made by the aeronaut Durouf, who carried a large number of despatches from the city, landing near Evreux, after being in the air about three hours. The success of this journey and several others that quickly followed led the French Government to establish a regular balloon-post, and to undertake the manufacture of balloons for this purpose. The mere matter of balloon construction offered no difficulty but a more serious one was met in the lack of experienced aeronauts. In this emergency, however, it occurred to the authorities that sailors, accustomed to climbing about at dizzy heights, might be taught to take the place of trained aeronauts. This experiment proved most successful, and in subsequent voyages these mariners maintained their reputation for daring undertakings. Between September and January sixty-four balloons were sent up, all but seven of which fulfilled their mission and delivered their despatches; and the total number of persons leaving Paris in balloons during the siege was one hundred and fifty-five. These carried with them a total of nine tons of despatches and something like three million letters, the speed with which these journeys were made ranging from a minimum of twenty miles an hour to a maximum velocity, in one instance, of eighty miles.

258

Shortly after this balloon-post was established, the Germans came into possession of the new Krupp long-range rifle, with which they succeeded in bringing down several of the balloons. Companies of Uhlans, the swiftest cavalry of Germany, scoured the country constantly, and kept

259

such a sharp lookout that, as the German lines were extended, it became difficult for the balloons to make their way over them in daylight. Night voyages, therefore, became necessary; but naturally these were extremely dangerous, and many of them had dramatic and tragic terminations. One of the longest and most famous of these voyages was that of the balloon named the *Ville d'Orléans*, which left Paris about midnight of November 24th. As a strong wind was blowing from the north at the time, it was hoped that the balloon would descend in the vicinity of Tours. The first intimation that the voyagers had that there was a deviation from this course was the sound of the waves breaking against the shore beneath them. At this time they were in a thick mist, and it was not until some time after daybreak that this mist cleared away sufficiently for them to get an idea of their surroundings. Then they found, to their horror, that they were over a large body of water, out of sight of land, in what part of the world they had not the slightest idea. The balloon appeared to be drifting rapidly, and from time to time they passed over vessels, which were frantically signaled by the voyagers. No notice was taken of these signals except by one vessel, which responded by firing several shots which went wide of the mark. The balloon continued on its course northward until late in the day when land was sighted lying to the northeast. By this time the ballast in the car had been entirely expended, and the balloon, which had been sinking gradually for several hours, seemed about to plunge into the ocean. In this extremity a heavy bag of despatches was thrown out, and the balloon thus lightened again rose to a considerable height, where another current of air carried it over the land.

260

A successful landing was made in Norway, in a desolate but friendly region, where the balloonists were treated with the greatest kindness. The balloon and its contents were subsequently secured, and all the despatches delivered to their proper destinations, except, of course, the one package that had been thrown out as ballast.

A week after the eventful voyage of the *Ville d'Orléans* a still more unfortunate ascent was made by a sailor named Prince, in the balloon called the *Jacquard*. As the ropes releasing this balloon were cut, the enthusiastic mariner, standing in his car and extending his hand toward the crowd, shouted dramatically, "I go upon a great voyage!" He did—and on one much greater than he anticipated—for the balloon was blown out to sea and lost. As he was passing over England after successfully crossing the Channel, he threw out his package of despatches, but this so lightened his balloon that it mounted quickly and was soon far out over the Atlantic. It was never heard of again. But the life of the enthusiastic voyager was not given in vain, for most of the despatches eventually reached their destination.

261

Although, as has been seen, the balloons sent out of Paris were not of the dirigible kind, and were entirely dependent upon the caprice of the winds, they fulfilled their missions quite as well as could be expected under the circumstances. In fact, there was small chance of failure, starting as they did from a central point, and being almost certain of success no matter what direction was taken, except, indeed, the one that would blow them over the German frontier. But the other part of the problem—the sending of balloons from the outside into Paris—was an entirely different proposition. So different, and so difficult, in fact, that it was never accomplished, although attempted several times.

But the millions of people in Paris, shut off completely from the outside world, were just as anxious to receive news as to send it. In attempting to establish communication from without, therefore, one balloon leaving the city in the early days of the siege, carried with it some trained dogs in the hope that they would make their way back to the city through the German lines. But either they lost their way, or were captured by the enemy, for nothing was ever heard of them after starting on the return trip. In this extremity the members of the "Société Colombophile" came forward with the offer of the use of their homing-pigeons. The society had a large number of these birds, trained to return to their cotes from long distances, and the experiment of sending return despatches with them was tried at once. Three birds were first sent out in one of the despatch-balloons, and within sixteen hours after starting these had all returned to the capital, bearing despatches. During the next few days a score more pigeons were sent out, eighteen of which returned safely with their messages; and thereafter a regular pigeon-post was organized.

262

As the weight that a pigeon is able to carry in its flight is extremely small, microscopic photography was resorted to, so that, although each bird carried only a single quill in which were rolled thin collodion leaves, the whole weighing only fifteen grains, the amount of printed matter thus carried was sometimes more than is contained in an ordinary volume.

By photographic methods, thirty-two thousand words, or about half an ordinary volume, were crowded upon a pellicule two inches long by one and one-quarter inches wide, and weighing about three-quarters of a grain! Twenty of these, representing six thousand words, or twice the amount of printed matter contained in such a book as Scott's *Ivanhoe*, or Prescott's *Conquest of Mexico*, were carried by each pigeon. One bird carried forty thousand complete messages on a single trip.

When the bird arrived at its cote, the quill was secured and taken to the government office, where the little leaflets were carefully removed, placed in an enlarging optical apparatus, thrown upon a screen with a magic lantern, and copied. The messages were then distributed to their destination about the city.

THE DIRIGIBLE BALLOON ACHIEVED

By this war, France, the home of the balloon, was brought keenly to realize the advantages and the limitations of such flying-machines; and it was but natural, under the circumstances, that as soon as peace was restored, efforts should be made there to produce a dirigible balloon, or some other form of dirigible flying-machine. Giffard, as we have seen, had been fairly successful; and now M. Dupuy de Lome, chief naval constructor of France, took up the problem. He constructed a balloon with a cigar-shaped envelope one hundred and twenty feet long and fifty feet in diameter. Beneath this was a rudder placed in the same position as that of a ship; and suspended still further below was a large car fitted with a two-bladed screw-propeller, thirty feet in diameter. Manual labor was to be used for turning this screw, two relays of four men each relieving each other at the work. An ascent was made in February, 1872, with fourteen persons in the car, who, by working in relays, demonstrated that a speed of about seven miles an hour could be maintained in any direction in still air. As the wind was blowing about thirty miles an hour at the time, however, the course of the balloon could only be deflected, and the main object of the ascent—the return to Paris—could not be accomplished. In short, De Lome's balloon demonstrated little more than had been accomplished by Giffard with his steam-driven balloon. Both had shown that with sufficient power the balloon could be made to travel in any direction in still air, but neither had been able to make headway against a strong wind.

It was estimated at the time of Dupuy de Lome's ascent, that had a steam-engine of a weight corresponding to that of the eight workmen been used, at least twice the power could have been obtained. But steam was considered too dangerous, and some other motive power which combined lightness with power seemed absolutely essential. The electric motor gave promise of success in this direction, and in 1883 the two Tissandier brothers in France applied such a motor to a balloon that was able to make headway against a seven-mile breeze, but was still far from fulfilling the requirements of an entirely dirigible balloon. Two years later the motor-driven balloon *La France*, of Renard and Krebs, attained a speed of fourteen miles an hour, and showed a distinct advance over all preceding models.

Meanwhile motors were being reduced in weight and increased in power, and the hearts of aviators and balloonists were cheered by the fact that the light metal, aluminum, was steadily growing cheaper. Visions of an all-aluminum balloon were constantly before the minds of the inventors, and in 1894 such dreams took practical form in a balloon whose construction was begun by Herr Schwartz, under the auspices of the German Government. This balloon was of most complicated construction, depending for its lifting power upon the gas-filled aluminum tank, but utilizing for its steering-gear many of the features of the aeroplane. It was essentially a balloon, not a flying-machine, however, with a ten to twelve horse-power benzine-engine actuating four propelling screws.

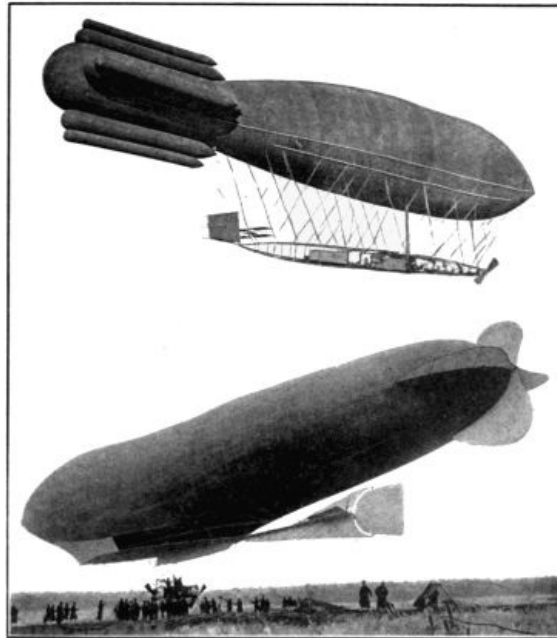

TWO FAMOUS FRENCH WAR BALLOONS.

The lower figure the dirigible war balloon "La Patrie," which manœvered on the Eastern boundary of France, and which was blown away and lost taking a northwesterly direction which probably landed it ultimately in the Arctic Sea—in 1908. The upper figure represents M. Deutsch's dirigible balloon "Ville de Paris" which was sent to the frontier to take the place of the lost "Patrie."

Before the balloon was completed Herr Schwartz died, but his plans were known to his wife, and, although considerably altered, were carried to completion. When all was finished, Herr Jaegels, an engineer who had had no experience as an aeronaut, volunteered to make an ascent and this metal ship-of-promise was launched. At first it rose rapidly and appeared to be making good progress against a strong wind; but suddenly it stopped, descended rapidly, and was

smashed to pieces, the aeronaut saving himself by jumping just before it touched the ground. It developed later that he had lost control of the machine, simply because the machinery was too complicated for a single operator to handle. On discovering this, Herr Jaegels, confused for the moment, threw open the valve, causing the balloon to descend too rapidly. Thus the fruit of years of study and labor and the expenditure of fifty thousand dollars in money resulted in only about six minutes of actual flight.

To most persons this experiment of the aluminum balloon would seem to have been a dismal failure, but it was not so regarded by the advocates of the dirigible balloon. The flight of the balloon, to be sure, was far from a success; but this was attributed to improper management rather than to any inherent defect in the balloon itself, or in the principle upon which it was constructed. Instead of being discouraged, therefore, the school of balloonists, who had lost some of their prestige of late by the performances of the flying-machines of Maxim and Langley, undertook, through their enthusiastic representative, Count Zeppelin, the construction of the largest, most expensive, and most carefully built dirigible balloon heretofore constructed. This balloon was of proportions warranting the name of "air-ship." The great cigar-shaped body was almost four hundred feet in length, and thirty feet in diameter—the proportions of a fair-sized ocean liner—and like the hull of its ocean prototype, was divided into compartments—seventeen in number, and gas-tight. Its frame-work was of aluminum rods and wires, and the skin of the envelope was made of silk, coated with india-rubber. It was equipped with four aluminum screws, and two aluminum cars were placed below the body at a considerable distance apart. The motive power was supplied by benzine motors, selected because of their lightness.

The company for constructing this balloon was capitalized at about two hundred thousand dollars, the cost of the shed alone, which rested on ninety-five pontoons on the surface of the lake of Constance, near the town of Manzell, being fifty thousand dollars. July 2nd, 1910, the count and four assistants in the cars, started on the maiden voyage. The balloon rose and made headway at the rate of eighteen miles an hour, responding readily to the rudder, but soon broke or deranged some of the steering-gear so that it became unmanageable and descended at Immerstaad, a little over three miles from the starting-point. Considering the amount of thought, care, and money that had been expended upon it, its performance could hardly be looked upon as a startling success. By the advocates of the aeroplane principle it was considered an utter failure.

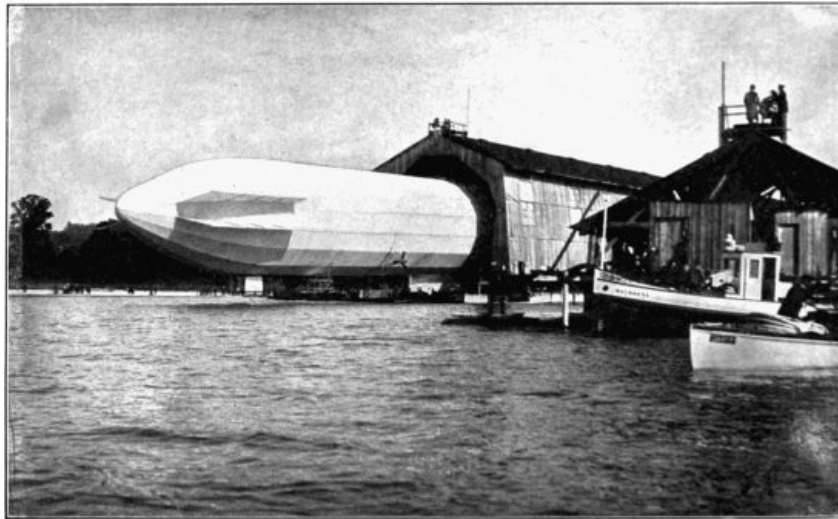

THE ZEPPELIN DIRIGIBLE BALLOON.

Count Zeppelin's famous balloons are of the semi-rigid type, being cased in thin loops of aluminum. The wing-like projections at the sides add greatly to the stability and dirigibility of the balloon. The problem of housing has been met by erecting a structure over the water. It is planned to have a balloon house that will revolve and thus facilitate the introduction of the balloon whatever the direction of the wind. With the above stationary house this is a difficult manœuvre if the wind chances to blow laterally.

But while Count Zeppelin was experimenting with his ponderous leviathan air-ship, a kindred spirit, the young Brazilian, M. Santos-Dumont, was making experiments along similar lines, but with balloons that were mere cockle-shells as compared with the German monster. The young inventor had come to Paris from his home in South America backed by an immense fortune, and by a fund of enthusiasm, courage, and determination unsurpassed by any aerial experimenter in any age. He began at once experimenting with balloons of different shapes, with screws and paddles, and, perhaps most important of all, with the new, light petroleum-motors just then being introduced for use on automobiles, electricity not having proved a success in aerial experiments.

His first balloon, *No. 1*, built in 1898, was devoid of any particularly novel features. His *No. 2* showed some advancement, and his *No. 3*, while a decided improvement, still came far short of answering the requirements of a dirigible balloon. But the young experimenter was learning and profiting by his failures—and, incidentally, was having hairbreadth escapes from death, meeting with many accidents, and being severely injured on occasion.

About this time a prize of one hundred thousand francs was offered by M. Deutsch to the aeronaut who should ascend from a specified place in a park in Paris, make the circuit of the Eiffel Tower, and return to the starting-point within half an hour. With the honor of capturing this prize as an additional incentive, Santos-Dumont began the construction of his fourth balloon, the *Santos-Dumont No. 4*. In this balloon everything but bare essentials was sacrificed to lightness, even the car being done away with, the aeronaut controlling the machinery and directing the movements of the balloon from a bamboo saddle. But an accident soon destroyed this balloon, and a fifth was hastily constructed. With this the enthusiastic aeronaut showed that he was almost within grasping distance of the prize in a series of sensational flights between the first part of July and the first week in August. The tower was actually rounded, but on the return trip the balloon collided with a high building in the Rue Alboni and was wrecked, the escape of the aeronaut without a scratch being little short of miraculous.

Nothing daunted, the inventor began the construction of *Santos-Dumont No. 6* immediately, finishing it just twenty-eight days after the construction of *No. 5*. A peculiarity of this balloon was that it was barely self-sustaining except when forced through the air by the propeller. The long cigar-shaped gas-bag was relatively small, and was filled to its limit of capacity with gas, while the lifting power was counterbalanced by the operator, car, engine, and ballast, so that the entire structure weighed practically the same as the air it displaced. At the stern was a powerful propeller. Obviously, then, if the long spindle-shaped machine was tilted upward at the forward end, and the propeller started, it would be driven upward; while if the forward end was lowered the propeller would drive it downward. If it was balanced so as to be perfectly horizontal, it would be forced forward in a horizontal direction. Deflections to right and to left were obtained by the ordinary type of vertical rudder; and thus any direction could be taken.

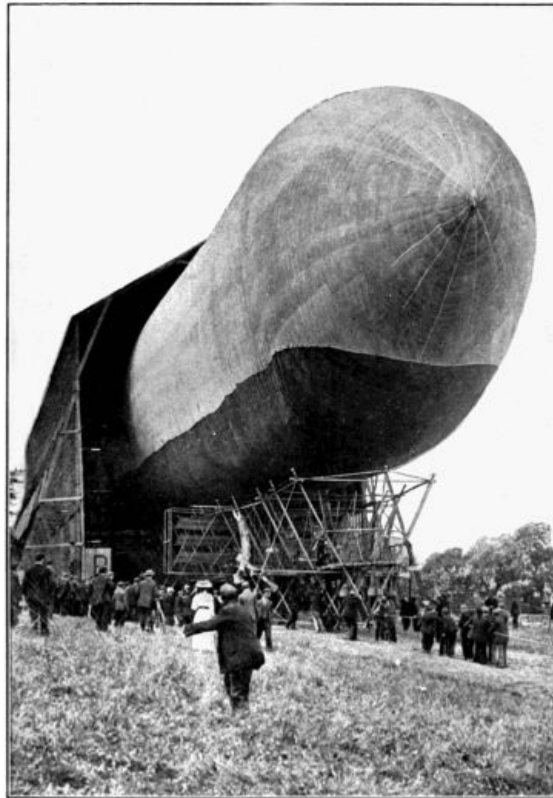

AN ENGLISH DIRIGIBLE BALLOON.

The photograph here reproduced gives a very vivid impression of the cumbersome nature of balloons of this modern type, and suggests the difficulties to be met in housing them safely when not in use.

To obtain the desired angle of inclination, Santos-Dumont made use of a sliding weight, and with this he guided his balloon upward and downward by shifting its position. Thus, although this balloon was a veritable balloon rather than a "flying-machine" proper, it really lacked the one essential common to balloons: it would not rise until propelled by mechanical means. It lacked the requisite of the flying-machine, however, in that it was not "many times heavier than the air." After giving this new balloon several preliminary trials, which included such exciting incidents as collisions with a tree in the Bois du Boulogne, an official attempt was made on October 29th, 1800. Above the heads of the gaping thousands, who, to a man, wished the daring navigator success, the balloon rounded the tower, and in twenty-nine minutes and thirty seconds from the moment of starting—thirty seconds less than the prescribed time-limit—the trip was successfully terminated.

This voyage must be considered as marking an epoch in aerial navigation. The dirigible balloon was accomplished. A decided step forward in the conquest of the air had been made, although from a practical standpoint this step was confessedly a short one. For while *No. 6* could be propelled in any direction under ordinary conditions, carrying a single passenger, it was on

the whole more of a toy ship than a practical sailing-craft. Nevertheless, its performance was a decided victory for the balloon over the flying-machine. No flying-machine of whatever type had ever even approached the performance of *Santos-Dumont No. 6*, which had carried a man on a voyage in the air, traveling with the wind, against it, and with the wind on either quarter at every possible angle at various times during the journey. And yet there were few scientists, indeed, if any, who considered that the problem of aerial navigation was solved; and to a large number Santos-Dumont's performance seemed little more than an extension of Giffard's idea, made possible by improved machinery not available half a century ago. To them it was the triumph of the energy, skill, and courage of an individual, not the triumph of a principle—which, after all, is the absolute essential.

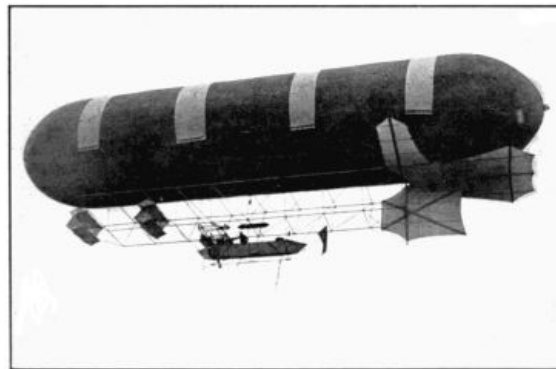
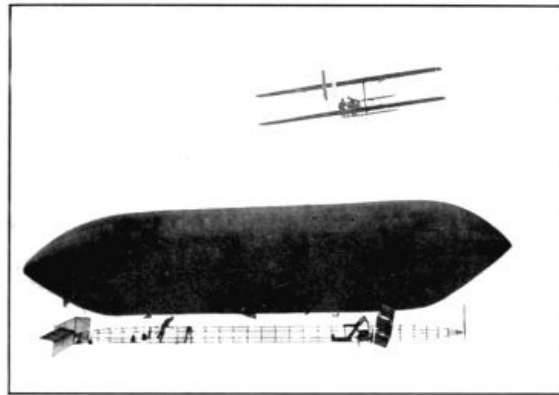

ENGLISH (LOWER FIGURE) AND AMERICAN DIRIGIBLE WAR BALLOONS
AND A WRIGHT AEROPLANE.

The above figures are introduced on one page for the purpose of comparison and contrast. The American balloon is the Baldwin airship. The essential clumsiness of a lighter-than-air craft, as contrasted with the relative gracefulness and manageableness of the aeroplane, is strikingly suggested by this illustration.

Since the successful performance of Santos-Dumont in rounding the Eiffel Tower many other dirigible balloons have been constructed, not only in America and in Europe by various inventors, but by the Brazilian aeronaut himself. The most remarkable of these is the *Zeppelin II*, the fifth creation of the indomitable Count Zeppelin. In principle and general lines of construction this balloon closely resembles the one described a few pages back. Its best performance, however, is more remarkable. Starting from Lake Constance on the night of May 29th, 1909, and sailing almost directly northward regardless of air currents, the balloon reached Bitterfeld, a few miles beyond Leipzig, four hundred and sixty-five miles from the starting-point, the following evening. Turning back at this point, without alighting, it had almost completed its return trip, when on coming to the ground for a supply of fuel it was injured by collision with the branches of a tree. The injury sustained, while delaying and marring the voyage, did not prevent the balloon from completing its eight-hundred-and-fifty mile voyage, and establishing a new record for dirigibles.

This and sundry other flights amply demonstrated the dirigibility and relative safety of the balloon under varying atmospheric conditions. But the difficulties that attend the management of such a craft when not high in air were again vividly illustrated when, in April, 1910, the *Zeppelin II*, was totally wrecked while at anchor by the force of a gale which it might easily have outridden had it been beyond the reach of terrestrial obstacles.

THE TRIUMPH OF THE AEROPLANE

ALTHOUGH the dirigible balloon in the hands of Santos-Dumont gained a decisive victory over all mechanical methods of flight theretofore discovered, even the inventor himself considered it rather as a means to an end, than the end itself. That end, it would seem, must be a flying-machine, many times heavier than the atmosphere, but able by mechanical means to lift and propel itself through the air. The natural representative of this kind of flying-machine, the bird, is something like a thousand times as heavy as the air which its bulk displaces. The balloon, on the other hand, with its equipments and occupants, must necessarily be lighter than air; and as the ordinary gas used for inflating is only about seven times lighter than the atmosphere, it can be readily understood that for a balloon to acquire any great amount of lifting power it must be of enormous proportions. To attempt to force this great, fragile bulk of light material through the atmosphere at any great rate of speed is obviously impossible on account of the resistance offered by its surfaces. On the other hand, any such structure strong enough to resist the enormous pressure at high speed would be too heavy to float.

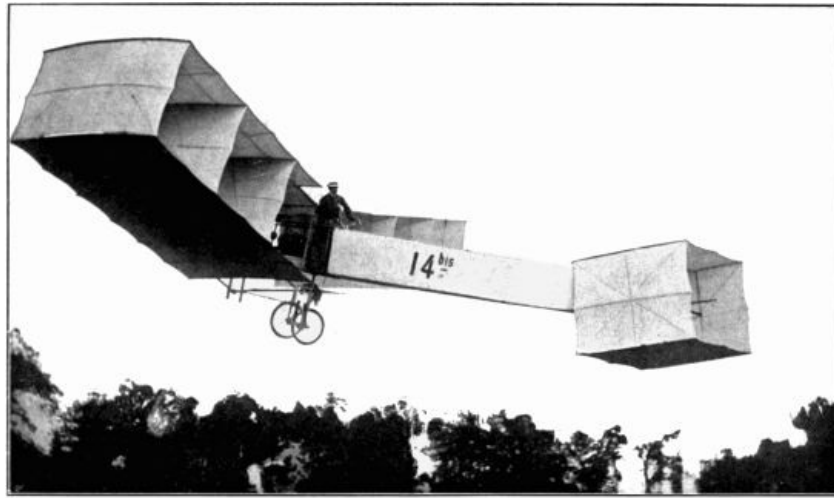

THE AEROPLANE OF M. SANTOS DUMONT.

M. Santos Dumont's chief fame as an aviator is based on his flights with a dirigible balloon. He has experimented extensively, however, with the heavier-than-air type of machine, though none of his flights with this apparatus has been record-breaking.

These facts are so patent that it is but natural to inquire how the balloonists could ever have expected to accomplish flight at more than a nominal rate of speed; and, on the other hand, it might be asked, naturally enough, how the aviators expected to fly with aeroplane machines at least a thousand times heavier than the air. In reply, the aviators could point to birds and bats as examples of how the apparently impossible is easily accomplished in nature; while the balloonists could simply point to their accomplished flights as practical demonstrations. The aviators could point to no past records of accomplishments, but nevertheless they had good ground for the faith that was in them, and as we shall see were later to justify their theories by practical demonstrations.

273

Everybody is aware that there is an enormous difference in the lifting power of still air and air in motion, and that this power is dependent upon velocity. The difference between the puff of wind that barely lifts a thin sheet of paper from the table, and the tornado that uproots trees and wrecks stone buildings, is one of velocity. Obviously, then, moving air is quite a different substance from still air when it comes to dealing with aeronautics.

One of the most familiar examples of the lifting power of moving air is that of the kite. An ordinary kite is many times heavier than the air and has no more tendency to rise in the air than a corresponding weight of lead under ordinary conditions. Yet this same kite, if held by a string with its surfaces inclined to the wind at a certain angle, will be lifted with a force proportionate to the velocity of the wind and the size of the surfaces. On a windy day the kite-flyer holding the string and standing still will have his kite pushed upward into the air by the current rushing beneath its surface. On a still day he may accomplish the same thing by running forward with the kite-string, thus causing the surface of the kite to "slide over" the opposing atmosphere. In short, it makes no difference whether the air or kite is moving, so long as the effect of the current rushing against the lower surface is produced. Obviously, then, if in place of the kite-flyer holding the string and running at a certain speed, some kind of a motor could be attached to the kite that would push it forward at a rate of speed corresponding to the speed of the runner, the kite would rise—in short, would be converted into a flying-machine.

274

Looked at in another way, the action of the air in sustaining a body in motion in the air has

been compared by Professor Langley to the sustaining power of thin ice, which does not break under the weight of a swiftly gliding skater, although it would sustain only a small fraction of his weight if he were stationary. Supposing, for example, the skater were to stand upon a cake of ice a foot square for a single second; he would sink, let us say, to his waist in the water. On a cake having twice the surface area, or two square feet, he would sink only to his knees; while if the area of the cake is multiplied ten times the original size, he would scarcely wet his feet in the period of a second. Now supposing the cake to be cut into ten cakes of one square foot each, placed together in a line so that the skater could glide over the entire ten feet in length in one second. It is evident that he would thus distribute his weight over the same amount of ice as if the cakes were fastened together in a solid piece.

275

"So it is with the air," says Professor Langley. "Even the viewless air possesses inertia; it cannot be pushed aside without some effort; and while the portion which is directly under the air-ship would not keep it from falling several yards in the first second, if the ship goes forward so that it runs or treads on thousands of such portions in that time, it will sink in proportionately less degree; sink, perhaps only through a fraction of an inch."

It is evident, therefore, that if, at a given speed, the horizontal wings of an air-ship would keep it from falling more than a fraction of an inch in a second, by increasing the speed sufficiently and giving the wings an upward inclination, the air-ship instead of falling might actually rise. And this, as we shall see presently, is just what the flying-machines of Sir Hiram Maxim and Professor Langley and of the Wright brothers and their imitators did do.

LANGLEY'S EARLY EXPERIMENTS AND DISCOVERIES

It was while making an important series of experiments with aeroplanes that Professor Langley made the discovery which has since been known as "Langley's Law." In effect this law is that while it takes a certain strain to sustain a properly disposed weight while stationary in the air, to advance the weight rapidly takes *even less strain* than when the weight is stationary. Thus, contrary to opinions held until recently, and contrary to the rules for land vehicles and ships, the strain of resistance of an aeroplane will diminish instead of increasing with the increase of speed. Professor Langley proved this remarkable fact with a most simple but ingenious device. It consisted of an immense "whirling table," driven by an engine, so arranged that the end of a revolving arm could be made to travel at any speed up to seventy miles an hour. At the end of this arm, surfaces disposed like wings were placed, and whirled through the two hundred feet circumference, until they were supported like kites by the resistance of the air.

276

A certain strain was, of course, necessary to support one of these winglike structures when stationary in the air, but, curiously enough, less strain was required when it was advanced rapidly. Thus a brass plate of proper shape weighing one pound was suspended from a pull-out spring scale, the arm of which was drawn out until it reached the one-pound mark. When the whirling table was rotated with increasing velocity the arm indicated less and less strain, finally indicating only an ounce when the speed of a flying bird was reached. "The brass plate seemed to float on the air," says Professor Langley, "and not only this, but taking into consideration both the strain and the velocity, it was found that absolutely less power was spent to make the plate move fast than slow, a result which seemed very extraordinary, since in all methods of land and water transport a high speed costs much more power than a slow one for the same distance."

These experiments, which destroyed the calculations of Newton, long held to be correct, showed that mechanical flight was at least theoretically possible, indicating as it did that a weight of two hundred pounds could be moved through the air at express-train speed with the expenditure of only one horse-power of energy. Since engines could be constructed weighing less than twenty pounds to the horse-power, theoretically such an engine should support ten times its own weight in horizontal flight in an absolute calm. As a matter of fact there is no such thing as an absolute calm in nature, air-currents being constantly stirring even on the calmest day, and this introduces another element in attaining aerial flight that is an all-important one. Indeed it has long been recognized that the mechanical power for flight is not the only requisite for flying—there is, besides, the art of handling that power.

277

EXPERIMENTS IN SOARING

Those who have watched soaring birds sail for hours on rigidly extended wings will remember that while there is no flying movement, there are certain shifts of the rigid body, either to offset some unexpected gust of wind, or to produce movement in a desired direction. There is an art of balancing here that has become instinctive in the bird by long practice which could not be hoped for in the same degree in a mechanical device, and which man could hope to acquire only by practice. But in the nature of the case man has little chance to learn this art of balancing in the air, and it is for this reason that the many members of the balloonist school advocate the inflated bag in place of the aeroplane. The argument advanced by them is that since man has no chance naturally to acquire familiarity with balancing in the air, the simplest and best way for him to acquire it is by making balloon ascensions. When he has acquired sufficient skill he can gradually reduce the lifting part of his flying-machine, or gas-bag, gradually increasing the aeroplane or other means of propulsion and lifting, until the balloon part of his device can be dispensed with entirely.

278

In short, this argument of the balloon advocates is comparable to two schools of swimming-teachers, one of whom advocates the use of sustaining floats until the knack of swimming is acquired, the other depending upon the use only of muscular movements and quickly acquired skill. In this comparison the aviators have all the best of the argument; for it is a common observation that persons who attempt to learn to swim by the use of floats of any kind acquire that art slowly if at all; while those who plunge in boldly, although they run more risks, quickly learn the art that seems ridiculously easy when once acquired.



LEARNING HOW TO FLY.

This gliding apparatus is not unlike that with which M. Chanute and other early experimenters tested the qualities of air currents. The apparatus here shown is being drawn by an automobile, so that its action is virtually that of a kite. This picture was taken at Morris Park, New York, in 1909. The descent was made too abruptly and the aviator was seriously injured.

The great German scientist, Helmholtz, after years of careful study, finally reached the conclusion that man would never be able to fly by his own power alone. But, as we have seen, Professor Langley had shown that in these mysterious questions pertaining to flight even a Newton could be wrong; and why not Helmholtz? Otto Lilienthal, also a German, thought that his fellow-countryman *was* wrong. For years he had made a study of the flight of birds, and his studies had led him to the same conclusions that have usually been reached by every student of the subject, both before and since—that soaring flight, without any flapping movement, is possible under certain conditions; that curved surfaces can acquire a horizontal motion by the action of the wind alone, "when their curvature bears a certain relation to their superficies"—in short, a relation represented exactly by the wings of birds.

279

It was not supposed by Lilienthal, or by any of the members of the school of aviators, that simply by making a device that reproduced the proportions and shape of a bird any person might mount and fly. But it was believed that, given such a device, a man might learn to fly with practice. Lilienthal, therefore, constructed a flying-machine with correctly curved surfaces made of linen stretched over a light wooden frame, the total area being about fourteen square yards, and the whole machine weighing only about forty pounds. In the center was an aperture where the operator was stationed, holding the frame in position by his arms. Obviously, as no flapping motion in imitation of a bird's wings was possible, some other means of giving the necessary impetus for horizontal flight was necessary, and here again the study of birds suggested a method.

It is a well-known fact that certain soaring birds cannot leave the ground when once they have alighted, except by an initial run to acquire the necessary speed; and every goose hunter is familiar with the manner in which these birds run along the surface of water, flapping their wings and skimming along some distance before they acquire sufficient velocity to mount into the air. A description of a similar action of an eagle in leaving the earth, written by a careful observer a few years ago, has become classic. This huntsman had come upon an eagle which had alighted upon the sandy banks of the Nile, and had fired at it, thus stimulating the bird to its utmost energy in getting into flight. Yet on examining the foot-marks made in the sand it was found that, even under these circumstances, the bird had been obliged to run "full twenty yards before he could raise himself from the earth. The marks of his claws were traceable on the sandy soil," says the writer, "as, at first with firm and decided digs, he found his way, but as he lightened his body and increased his speed with the aid of his wings, the imprints of his talons gradually merged into long scratches."

280

It is evident that if such a master of the art of flying as an eagle must thus acquire initial velocity before flight is possible, a human novice must do considerably more. The method that would naturally suggest itself would be that of running down the slope of a hillside, and Lilienthal adopted this method, beginning his flights by running down the gentle slope of a hill against the wind, until the requisite momentum was acquired. This was, indeed, a reversion to some of the

oldest types of flying-machines, but with this difference—that it was the result of scientific study. The results attained proved that the theory was not visionary—that scientists had not dreamed and studied in vain. For, as little by little the experimenter gained experience, he was able to soar farther and farther in his birdlike machine, in one flight sailing a distance of twelve hundred feet. Under certain favorable wind conditions he could sail from a hilltop without the initial run, and at times he actually rose in the air to a point higher than that from which he started.

281

As was to be expected in the very nature of the case, Lilienthal found that part of the secret of success lay in maintaining his equilibrium and in acquiring the faculty of doing this instinctively, as a bird does. But he found, like the person learning to ride a bicycle, that this was developed by repeated efforts. The action of the machine itself was carefully studied, and various changes were made in his apparatus from time to time as experience suggested them. Among other things, feather-like sails, worked by a small motor, were attached to the edge of the wings; and two smaller frames placed one above the other were tried in place of one large frame. And still the operator continued to make successful flights in all kinds of winds, sometimes narrowly escaping disaster, but for three years always coming to the ground safely. His confidence increased day by day, and as his remarkable performances multiplied it seemed as if it would only be a matter of time until he would be able to imitate the soaring bird and sail almost as he pleased.

In writing of his experiences when, as it sometimes happened, he found himself practically motionless in the air at a point higher than that from which he started, he says: "I feel very certain that if I leaned a little to one side, and so described a circle, and further partook of the motion of the lifting air around me, I should sustain my position. The wind itself tends to direct this motion; but then it must be remembered that my chief object in the air is to overcome the tendency of turning to the right or left, because I know that behind or under me lies the hill from which I started, and with which I would come in rough contact if I allowed myself to attempt this circle-sailing. I have, however, made up my mind, by means of either stronger wind or by flapping the wings, to get higher up and farther away from the hills, so that sailing round in circles, I can follow the strong, uplifting current, and have sufficient air-space under and around me to complete with safety a circle, and lastly to come up against the wind again to land."

282

Before he was ready to make this attempt, however, Lilienthal was killed by a fall caused by a treacherous gust of wind which tilted his machine beyond his control and hurled him to the ground.

Again the expectant world of aerial navigators was thrown into despondency by the happening of the long expected—expected, and yet not expected; for Lilienthal had made so many daring flights under so many trying conditions, always managing to alight safely, that a feeling of confidence had succeeded that of distrust. It was almost like a bolt from a clear sky, therefore, when the news was flashed around the world that Lilienthal was no more. But science has never yet been daunted by the fear of death. Like a well-formed battle-line in which the place of the fallen is always quickly filled, there is always a warrior-scientist ready to sacrifice anything for the cause. And so, although Lilienthal was gone, the work he had carried so far toward success was continued by others, Chanute and Hering, the American "soaring men," and later eclipsed by the Wright brothers, who were finally to solve the problem.

283

THE FLYING MACHINES OF MAXIM AND LANGLEY

At the same time that Lilienthal was making his initial experiments, another champion of the same school of aviators was achieving equally successful results along somewhat different, and yet on the whole, similar lines. Sir Hiram Maxim, the inventor of so many destructive types of guns, was devoting much time and energy to the construction of a flying-machine. His apparatus was of the aeroplane type, but unlike that of Lilienthal, Chanute, or Hering, was to be propelled by steam-driven screw-propellers. Nor was the apparatus he proposed to make a diminutive affair weighing a few pounds and capable of lifting only the weight of a man. His huge machine weighed in the neighborhood of four tons and carried a steam-engine that developed some three hundred and sixty horse-power in the screws. It was two hundred feet in width, and mounted on a car track, along which it was to be run to acquire the necessary initial velocity before mounting into the air.

On July 31, 1894, this huge machine started on a trial spin, carrying a crew of three persons, besides fuel and water for the boilers. When a speed of thirty-six miles an hour on the track had been acquired, the apparatus lifted itself in the air, and sailed for some distance, a maximum flight of over three hundred feet finally being made. This experiment demonstrated several important things—in fact, solved "three out of five divisions of the problem of flight," as Lord Kelvin declared. It demonstrated that a flying-machine carrying its own propelling power could be made powerful and light enough to lift itself in the air; that an aeroplane will lift much more than a balloon of equal weight; and that a well-made screw-propeller will grip the air sufficiently to propel a machine at a high rate of speed.

284

Since the two remaining divisions of the five concerned in the problem of flight had been already solved by Lilienthal, it seemed that it only remained for some scientist to combine this complete knowledge in the proper way to produce a practical flying-machine—one that would fly through the air, and continue to fly until the power was exhausted. It was not a startling announcement to the scientific world, therefore, when about three years later the news was flashed that Prof. S. P. Langley had produced such an apparatus.



FLYING MACHINES OF THE MONOPLANE TYPE.

Upper figure, the aeroplane of M. Robert Esnault-Pelterie. Middle figure, the aeroplane of M. Blériot. Lower figure, the Vuia aeroplane, a bat-like machine of freakish structure which had no large measure of success. A modification of the boat-like machine shown in the upper figure gained celebrity through its use by M. Latham in the first attempt (in July, 1909) to fly across the English Channel. M. Blériot's aeroplane as finally developed became a very successful flying machine. With its aid M. Blériot was first to accomplish the feat of flying across the English Channel (from Calais to Dover in about 23 minutes) on the morning of July 25th, 1909. These pictures are reproduced from the London Graphic of January 25th, 1908.

Professor Langley described this really wonderful machine, which he called the "aerodrome," as follows:

"In the completed form there are two pairs of wings, each slightly curved, each attached to a long steel rod which supports them both, and from which depends the body of the machine, in which are the boilers, the engines, the machinery, and the propeller wheels, these latter being not in the position of an ocean steamer, but more nearly amidships. They are made sometimes of wood, sometimes of steel and canvas, and are between three and four feet in diameter.

285

"The hull itself is formed of steel tubing; the front portion is closed by a sheathing of metal which hides from view the fire-grate and apparatus for heating, but allows us to see a little of the coils of the boiler and all of the relatively large smokestack in which it ends. There is a conical vessel in front which is simply an empty float, whose use is to keep the whole from sinking if it should fall in the water.

"This boiler supplies steam for an engine of between one and one-half horse-power, and, with its fire-grate, weighs a little over five pounds. This weight is exclusive of that of the engine, which weighs, with all its moving parts, but twenty-six ounces. Its duty is to drive the propeller wheels, which it does at rates varying from 800 to 1,200, or even more, turns a minute, the highest number being reached when the whole is speeding freely ahead.

"The rudder is of a shape very unlike that of a ship, for it is adapted both for vertical and horizontal steering. The width of the wings from tip to tip is between twelve and thirteen feet, and the length of the whole about sixteen feet. The weight is nearly thirty pounds, of which about one-fourth is contained in the machinery. The engine and boilers are constructed with an almost single eye to economy of weight, not of force, and are very wasteful of steam, of which they spend their own weight in five minutes. This steam might all be recondensed and the water re-used by proper condensing apparatus, but this cannot be easily introduced in so small a scale of construction. With it the time of flight might be hours instead of minutes, but without it the flight (of the present aerodrome) is limited to about five minutes, though in that time, as will be seen presently, it can go some miles; but owing to the danger of its leaving the surface of the water for that of the land, and wrecking itself on shore, the time of flight is limited designedly to less than two minutes."

286

When this flying-machine was put to the actual test its performance justified the most sanguine expectations; it actually flew as no other machine had ever flown before. A number of men of science watched this remarkable performance, among others Alexander Graham Bell, the inventor of the telephone, who reported it to the Institute of France. "Through the courtesy of Mr. S. P. Langley, Secretary of the Smithsonian Institution, I have had on various occasions the pleasure of witnessing his experiments with aerodromes," wrote Dr. Bell, "and especially the remarkable success attained by him in his experiments made on the Potomac River on

Wednesday, May 6th [which led me to urge him to make public some of these results].

"On the occasion referred to, the aerodrome, at a given signal, started from a platform about twenty feet above the water, and rose at first directly in the face of the wind, moving at all times with remarkable steadiness, and subsequently swinging around in large curves of, perhaps, a hundred yards in diameter, and continually ascending until its steam was exhausted, when at a lapse of about a minute and a half, and at a height which I judged to be between eighty and one hundred feet in the air, the wheels ceased turning, and the machine, deprived of the aid of propellers, to my surprise did not fall, but settled down so softly and gently that it touched the water without the least shock, and was in fact immediately ready for another trial."

287

To most persons, even to the cautious and scientific inventor himself, the performance of this, and a second aerodrome which flew about three-quarters of a mile, seemed to show that the secret of aerial navigation was all but fathomed. "The world, indeed, will be supine," Langley wrote a short time after the success of his flying-machine, "if it does not realize that a new possibility has come to it, and that the great universal highway overhead is soon to be opened." What could be plainer? A machine of a certain construction, weighing some thirty pounds, and carrying at that some excess of weight, had been able to fly a relatively long distance. What easier than to construct a machine on precisely similar lines only ten, a hundred, a thousand times larger, until it would carry persons and cargo, and fly across an ocean or a continent?

Professor Langley himself, as was most fitting, undertook the construction of such a man-carrying air-ship. And it was during this undertaking that he made the momentous discovery that seemed to oppose a question mark to the possibility of flight by the aeroplane principle. This discovery was an "unyielding mathematical law that the weight of such a machine increases as the cube of its dimensions, whereas the wing surface increases as the square." In other words, as the machine is made larger, the size of the wings must be increased in an alarmingly disproportionate ratio. And the best that Professor Langley's man-carrying flying-machine could do, after the inventor had expended the limit of his ingenuity, was to dive into the waters of Chesapeake Bay, instead of soaring through the air as its prototype, the aerodrome, had done.

288

THE IMPOSSIBLE ACCOMPLISHED

The plunge of Langley's aerodrome downward into the water instead of upward through space as had been confidently expected, carried with it the hopes of a great number of hitherto enthusiasts, who were now inclined to believe that the practical conquest of the air was almost as far beyond our reach as it had been beyond that of all preceding generations. Learned scientists were able to prove to their own satisfaction, by long columns of figures and elaborate mathematical calculations, that the air is unconquerable.



THE WRIGHT AEROPLANE.

The aeroplane is here shown at rest, facing the right. This is the original type of bi-plane flying machines, of which all the others are only modifications. The starting-rail along which the machine glides while acquiring momentum is seen at the right; the rope connecting it with the starting derrick, at the left. The sledge-like runners, intended to break the shock of alighting, are plainly shown. The parallel planes of canvas at the right are horizontal rudders to direct the machine upward or downward. The vertical planes at the left are active rudders to direct the machine laterally. The two paddle-like structures at the back of the machine are the wooden propellers, actuated (at a rate of from 1000 to 1400 revolutions per minute) by an oil motor. With a machine of this type the Wright brothers, of Dayton, Ohio, were the first to demonstrate the feasibility of aerial navigation with a heavier-than-air machine; and world-famous flights were made by Mr. Orville Wright at Washington and by Mr. Wilbur Wright in France in the summer of 1908.

But even as they labored and promulgated these conclusions, two unknown men in a little Ohio town, discarding all accepted theoretical calculations, and combining with their newly created tables of figures a rare quality of practical application and unswerving courage, had accomplished the impossible. Wilbur and Orville Wright—two names that must always be linked with those of Fulton and Stephenson, only possibly on a higher plane as conquerors of a more subtle element—were at that very time making flights in all directions at will through the air in their practical flying-machine. While others caviled and doubted, these two modest inventors worked and accomplished; until presently they were able to put in evidence a mechanism that may perhaps without exaggeration be regarded as the harbinger of a new era of civilization.

289

The interest of these two brothers in the fascinating field of air navigation was first excited when, as boys, their father, a clergyman, brought home for their amusement the little toy known to scientists as a "hélicoptère," which, actuated by twisted rubbers that drive tiny paper screws in opposite directions, actually rises and flutters through the air. "A toy so delicate lasted only a short time in the hands of small boys, but its memory was abiding" the inventors themselves have tersely said. So abiding, indeed, that a few years later they began making similar "bats," as they had dubbed the machines.

Soon they discovered that the larger the machine they made the less it flew, and in pondering this fact they gradually evolved for themselves the theory which is now known as Langley's unyielding mathematical law, referred to a few pages back. The problem of human flight had not been considered by them at this time, and it was not until the news of Lilienthal's death startled the world that they entered the field of invention in earnest. Then they began constructing gliding machines, modifications of those of Lilienthal and Chanute, and began making long flights, studying defects and overcoming adverse conditions as they presented themselves.

By 1901, they had surpassed the performances of all predecessors, yet, as they tell us, "we saw that the calculations upon which all flying-machines had been based were unreliable, and that all were simply groping in the dark. Having set out with absolute faith in the existing scientific data, we were driven to doubt one thing after another, till finally, after two years of experiment, we cast it all aside, and decided to rely entirely upon our own investigations. Truth and error were everywhere so intimately mixed as to be indistinguishable. Nevertheless, the time expended in preliminary study of books was not misspent, for they gave us a good general understanding of the subject, and enabled us at the outset to avoid effort in many directions in which results would have been hopeless."

290

From mere gliding machines without self-contained power the brothers progressed through the various stages of achievement until in the fall of 1903 they had created the type of flying-machine now made so familiar to everyone through the pictorial publications. Incidentally they had invented and constructed their own gasoline motor for furnishing the power—an accomplishment of no mean importance in itself. On December 17th, 1903, in the presence of a small company of witnesses who had braved the cold, the Wright machine, carrying one of the brothers, made a short but successful flight—the first ever accomplished in which a machine carrying a passenger had raised itself by its own power, sailed a certain distance in free flight, yet subject to guidance, and landed itself and its passenger safely. Mr. Hiram Maxim's machine had, indeed, lifted itself and its passengers, but it sailed unguided through the air, and it could in no sense be said to have made a flight comparable to that of a bird or a bat. The Wright machine, on the other hand, progressed through the air under guidance of its passenger, rising or settling, or turning to right or left as he wished. Its progress constituted, in other words, a veritable flight.

291

Yet the problem of perfectly controlled flight under all ordinary conditions was by no means completely mastered. The principle was correct, but there were endless details to be worked out. The embodiment of these is the Wright flying-machine of the present time.

In the Wright aeroplane the lifting power is obtained by two parallel horizontal planes of canvas stretched over retaining-frames, placed with their long diameters transversely to the direction of flight, as in the case of the wings of a bird. At a little distance, in front of these, are placed two horizontal parallel rudders, and at the back two parallel vertical rudders. The machine is mounted on huge skids, which resemble giant sled-runners in shape, but lighter and more flexible, and is driven by two wooden-bladed propellers not unlike some of the types of ship-propellers. For stability in flight under all kinds of atmospheric conditions this machine has shown itself to be a true flying-machine, capable of navigating the air in any direction at the will of the operator, and remaining in flight a length of time dependent entirely upon the amount of fuel carried.

The stability of this machine, particularly in a transverse direction, has proved far greater than that of any of its predecessors or contemporaries. The two horizontal rudder-planes mounted in front maintain the fore-and-aft stability; while keeping the machine on an even keel is accomplished by varying the angle of incidence by warping the two main planes,—this being, indeed, a vitally important feature of the mechanism. In this manner a greater lift on the low side and a diminished lift on the high side is obtained, this being maintained manually, as is the fore-and-aft stability. Since the warping of the wings of the machine would tend to deflect it from its course, the apparatus is so arranged that a single lever controls the flexible portion of the wings and the vertical rudder, the motion of the latter counteracting the disturbing influence that would otherwise result from the twisting of the wing-tips. The discovery of this combination gave the finishing touches to the aeroplane, and made it a manageable mechanism. In other words, it made the flying machine a machine in which man could fly.

292

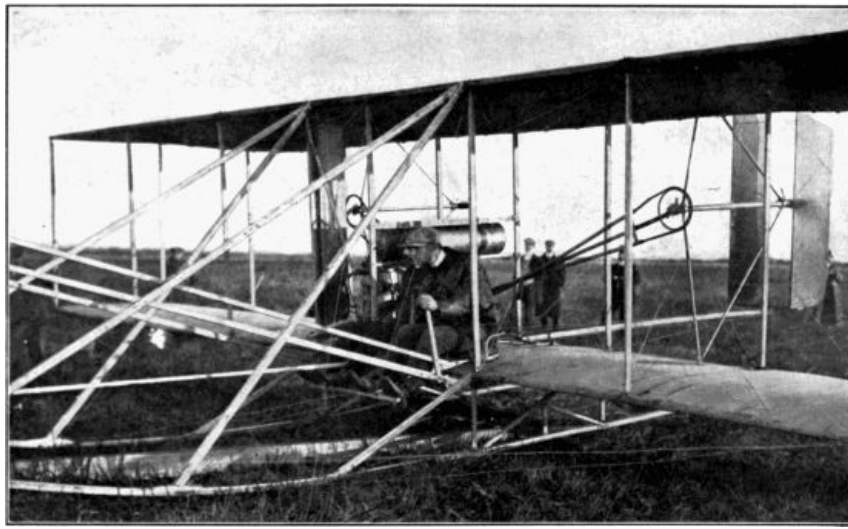

MR. WILBUR WRIGHT PREPARING TO ASCEND IN HIS AEROPLANE WITH HIS PUPIL M. CASSANDIER.

This mechanism was patented in 1906, and the patent office specifications then became accessible to other experimenters. The French scientific workers had for some time recognized the success of the Wright brothers' efforts, even when most Americans were still skeptical. Now that the manner in which this success had been obtained was disclosed, numerous experimenters began copying the Wright brothers' successful machine, making sundry modifications, while still adhering to the main principles through which success had been obtained. The first of these experimenters to win conspicuous success was Mr. Henry Farman, an Englishman residing in Paris, who on the 13th of January, 1908, aroused the enthusiasm of the entire world, and won a £2000 prize, by flying in a heavier-than-air machine in a prescribed circle, covering about sixteen hundred yards, and alighting at the starting-point.

293

This was more than four years after the Wright brothers had made far more remarkable flights, to which few persons had paid any attention, and of which most people had never heard. But in the autumn of the same year Orville Wright in America, and Wilbur Wright in France began a series of public flights which demonstrated for all time that the air at last had been conquered, and that they were the unquestionable conquerors. Orville, at Fort Myer, near Washington, on September 12th, electrified the world by flying continuously around a circular course for an hour and fifteen minutes. This was the most conclusive performance yet accomplished and set at rest all doubts as to the possibility of mechanical flight. For no one could doubt that a machine which could maintain itself in the air by its own power for more than an hour was truly a flying-machine in the most exacting sense of the term.

A few days after this performance an accident to the propeller of this machine wrecked it, the resulting fall breaking the leg of the inventor, and killing his companion, Lieutenant Selfridge of the United States Army.

Almost simultaneously Wilbur Wright began a series of flights at Le Mans, France, which demonstrated still more conclusively that erstwhile earth-bound man had really learned to fly. His longest flight lasted for two hours, twenty minutes, and twenty-three seconds; while by flying over captive balloons at an altitude of three hundred and sixty feet, he demonstrated that the mere matter of altitude offered no obstacle.

294

From this time forward the number of aeronauts increased day by day, and new records were made in bewildering confusion. Only a few of the more spectacular of these need be referred to. On July 19, 1909, Hubert Latham attempted a flight across the English Channel, but his motor failed him and his machine plunged into the water, from which, however, he was rescued, having suffered no injury. On July 25th, Louis Blériot made a similar attempt with better results. Starting from the cliffs near Calais he made the passage without mishap and landed near Dover.

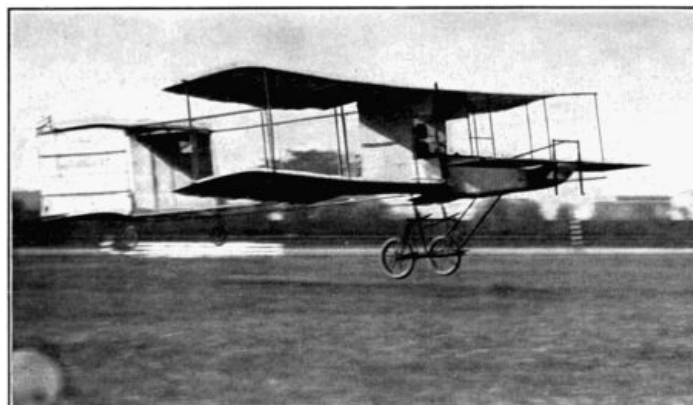

This is the machine with which Mr. Farman, an Englishman living in France, won the Deutsch prize in the early spring of 1908. This performance was notable as being the most important public flight hitherto made by a heavier-than-air machine. The Wright brothers of Dayton, Ohio, had made numerous flights of far greater length, but the general public was not aware of that fact and for a time Mr. Farman was popularly regarded as the foremost of aviators. His best performances were, however, eclipsed by the public flights of the Wright brothers a few months later.

There was of course no particular difficulty involved in the flight across the Channel; but its obvious dangers, together with the suggestion as to the new possibilities of the use of the airship in war time,—the virtual elimination of that all-important barrier of water that had proved so effective against England's foes in the past,—gave to Blériot's flight a popular interest not exceeded by any preceding achievement even of the Wright brothers. We may add that Blériot's feat was presently duplicated by another Frenchman, Count Jacques de Lesseps by name, who crossed the Channel in an aeroplane in May, 1910; and excelled by the Hon. Charles S. Rolls, an Englishman, who on June 2nd, 1910, made a still more remarkable flight, in which he crossed the Channel, starting from the cliffs near Dover, and after circling over French soil without landing, returned to his starting-place. The aeroplanes used by the two Frenchmen were of the monoplane type; that used by Mr. Rolls was a Wright bi-plane.

295

Just at the time when the first successful cross-Channel flight was made, the attention of aviators was focussed on the flights being made near Washington by Mr. Orville Wright in the attempt to fulfill the Government tests which had been so tragically interrupted the year before. On July 27th, 1909, Mr. Wright successfully met the conditions of the endurance test, by flying more than an hour carrying as a passenger Lieutenant Frank P. Lahm. Three days later a more spectacular flight, to a distance of five miles across country and return, over tree-tops, hills, and valleys, with a passenger (Lieutenant Foulois), was accomplished without mishap. This was in many respects the most important flight, as suggesting the possible practical utility of the aeroplane, that had hitherto been made.

Later in the same year Mr. Orville Wright went abroad with his aeroplane and made a large number of flights at Berlin, demonstrating to the German people the points of superiority of the aeroplane as against the gigantic dirigible balloons to which that nation had heretofore paid chief attention. Mr. Wilbur Wright meantime remained in America to give flights about New York Harbor during the Hudson-Fulton Centenary Celebration. On October 4th (1909), he made a sensational flight up the Hudson from Governor's Island, circling about above the warships anchored in the river in the neighborhood of Grant's Tomb, and returning to land at his starting-point. What would probably have been a still more spectacular flight was prevented by an accident to Mr. Wright's motor just as he was about to start on the afternoon of the same day.

296

Another flight that aroused great popular interest and enthusiasm was made by the Frenchman Louis Paulhan in competition for a prize of ten thousand pounds offered by the Daily Mail of London for a flight from London to Manchester. Paulhan left London at 5:20 on the evening of April 28, 1910. He descended at Litchfield but renewed his flight early next morning, arriving at Manchester at 8:10. He had covered the distance of 186 miles with a single stop, his actual flying time being four hours and eleven minutes, or an average rate of 44.3 miles an hour. In this flight M. Paulhan had for his only competitor Mr. White, an Englishman, who made a daring flight but did not cover the entire distance.

Paulhan had previously been known as one of the most daring of aviators. At Los Angeles, California, on January 13, 1910, he rose to a height of about 4,163 feet, establishing a record for altitude. He had also made thrilling cross-country flights on the occasion of the Los Angeles meet, as well as in France. Paulhan's record flights were made in a Farman bi-plane.

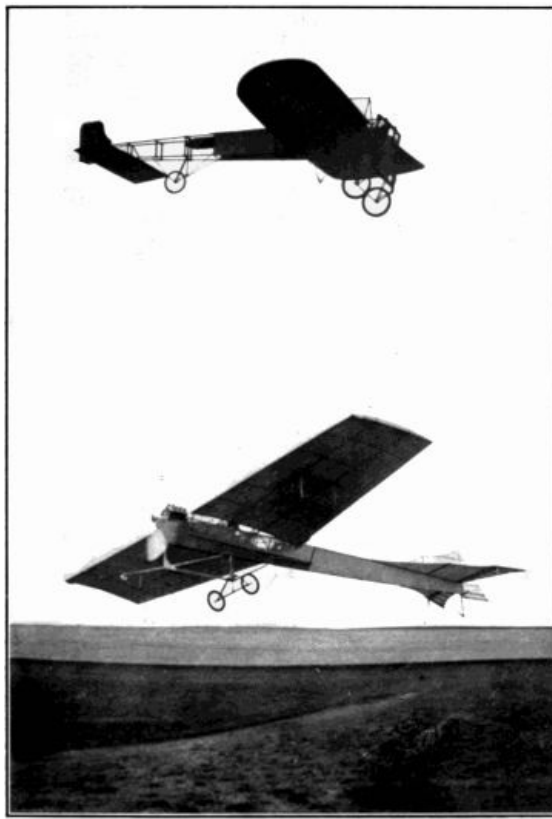

THE MONOPLANES OF BLÉRIOT AND LATHAM.

The upper figure is that of Blériot launched for his flight across the English Channel, on July 25th, 1909. The lower shows Latham starting in an attempt to cross the Channel, which barely failed of success through fault of the motor.

The spectacular flight from London to Manchester was matched soon after by Mr. Glenn H. Curtiss' flight from Albany to New York, which took place May 29, 1910. Mr. Curtiss had already achieved fame as an aviator, having won the chief speed contest in the International Aviation Meet held at Rheims in August, 1909. He used a bi-plane of his own construction, differing but little in design from the Wright machine, but of very small size, and propelled by an eight-cylinder motor, also made by Mr. Curtiss himself. The start from Albany was made at three minutes after seven o'clock and the aviator arrived at Governor's Island, New York Harbor, at twelve o'clock, having stopped twice on the way to rest and take on fuel. The first stop was made near Poughkeepsie, the second on the heights near the Hudson, within the bounds of New York City. The distance covered 142-1/2 miles; the actual time of flight, 2 hours and 54 minutes,—an average speed of about fifty miles an hour. Parts of the flight were made at a good deal better speed. The first part of the journey from Albany to Poughkeepsie, a distance of 74-1/4 miles, was covered in 1 hour 23 minutes, or at a rate of more than 53.68 miles an hour. The minimum speed at which Mr. Curtiss' bi-plane could be maintained in the air is about 40 miles an hour, the supporting surface of its main plane comprising only 236 square feet, and the weight of the machine complete, including aviator, fuel, and oil, being 950 pounds. The machine uses a single propeller, 7 feet in diameter, making 1,100 revolutions per minute, and giving a pull, when the machine is held stationary on the ground, of over 300 lbs. The engine used is an eight-cylinder motor of 50 horse-power.

297

A flight in some respects even more interesting than that of Mr. Curtiss was accomplished in France on the ninth of June, 1910, by Lieutenant Feguant and Captain Marconnet, officers of the French army, on a Farman bi-plane. "Starting from Chalons at 4:40 A. M.," says the *Scientific American*, "the officers flew 176 kilometers (109-1/4 miles) across country to the artillery park at Vincennes, which was reached at 7:10. This flight of two and one-half hours' duration was accomplished at a speed of 43-3/4 miles per hour. Captain Marconnet was able to take photographs and make sketches that would have been of great strategic interest in time of war. This is the first practical demonstration of the aeroplane for scouting purposes, in addition to its being a new world's record for cross-country flying with two men in the machine. Another French aviator, Labouchère, flew for ten minutes with two passengers at Mourmelon on the same day."

298

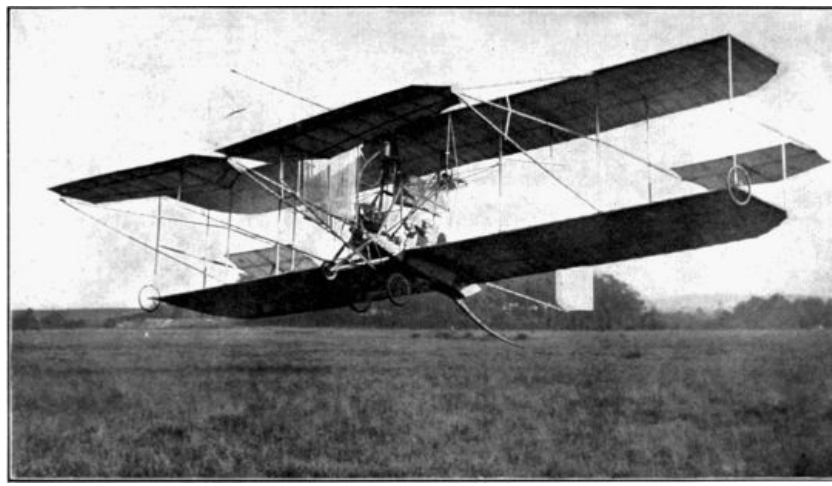

A BRITISH AEROPLANE.

This apparatus was built and is operated by Colonel Cody of the British Army. It has made flights of a mile or more. With minor modifications it is, like all bi-plane flying machines hitherto constructed, of the Wright aeroplane type.

A record flight of yet another character was accomplished in America by Charles K. Hamilton, a disciple of Curtiss, who, flying under the auspices of the *New York Times* and the *Philadelphia Public Ledger*, attempted successfully a round-trip flight from New York to Philadelphia on June 14, 1910. The aviator left Governor's Island at 7:36 A. M. and landed at Philadelphia at 9:26 A. M., having covered the 86 miles at an average speed of 46.92 miles an hour. After delivering messages from the Governor of New York, and the Mayor of New York City, Mr. Hamilton took wing at 11:33 for the return voyage. A difficulty with his motor made it necessary for him to descend at South Amboy, after covering 68 miles in 1 hour and 21 minutes. An injury to the propeller necessitated a delay of several hours, but the aviator was enabled to re-ascend at 6:17 and to land at Governor's Island at 6:40, the return journey having been accomplished at an average hourly speed of 51.36 miles.

299

The machine used by Mr. Hamilton is a Curtiss bi-plane, which in most respects follows closely the model of the original Wright aeroplane, but in which the function of the warping wings is fulfilled by two small wings, or ailerons, adjusted at each side between the larger planes. These ailerons, being deflected in opposite directions simultaneously, meet any tendency of the machine to tip unduly. Whether or not this method of maintaining lateral stability is the same in principle as the Wright method of warping the large planes themselves, is a question at issue between the inventors. From the purely scientific standpoint it would seem that one method is merely a modification of the other, which, however ingenious in its application, introduces no new principle.

On the same day on which Mr. Hamilton's inter-urban flight took place, a new record for altitude was made at Indianapolis by Mr. W. H. Brookins, a pupil of the Wrights, who rose in the Wright bi-plane to a height of 4,384 feet. The height was calculated by President Lambert of the St. Louis Aero Club, with the aid of a sextant. Earlier in the same day Mr. Brookins had risen about 2,000 feet. It becomes increasingly difficult for an aeroplane to rise to great heights owing to rarefaction of the upper atmosphere, but the flights of Paulhan and Brookins, as well as various unmeasured altitudes attained in cross-country flights, show that the aeroplane as at present equipped may be depended upon to rise well toward the mile limit.

300

These are but a few of the interesting flights made within a brief period after the Wright brothers' first successful demonstrations. The number of the aviators who so quickly entered the field, and the prominence given by the press to such feats as those of Blériot, Paulhan, and Curtiss, have tended to distract attention from the original inventors, and to produce some confusion in the popular mind as to the exact share the various aviators have taken in the conquest of the air. The facts, however, are quite clear and unequivocal. At the time when the Wright brothers made their first successful flights, comparatively few people in the world believed that anyone would ever be able to propel himself through the air with safety or certainty in a heavier-than-air apparatus.

The Wright brothers solved the problem after years of patient effort, and solved it effectively and conclusively. They profited of course by the efforts of predecessors, but they were the inventors of the airship in a far fuller sense than, for example, Fulton was the inventor of the steamboat, or Stephenson of the locomotive, or Morse of the telegraph. To their success, and to that alone, must be ascribed the fact that many scores of men in various parts of the world are now able to fly in aeroplanes. Slight modifications of type mark various of these aeroplanes, but no radical departure in principle.

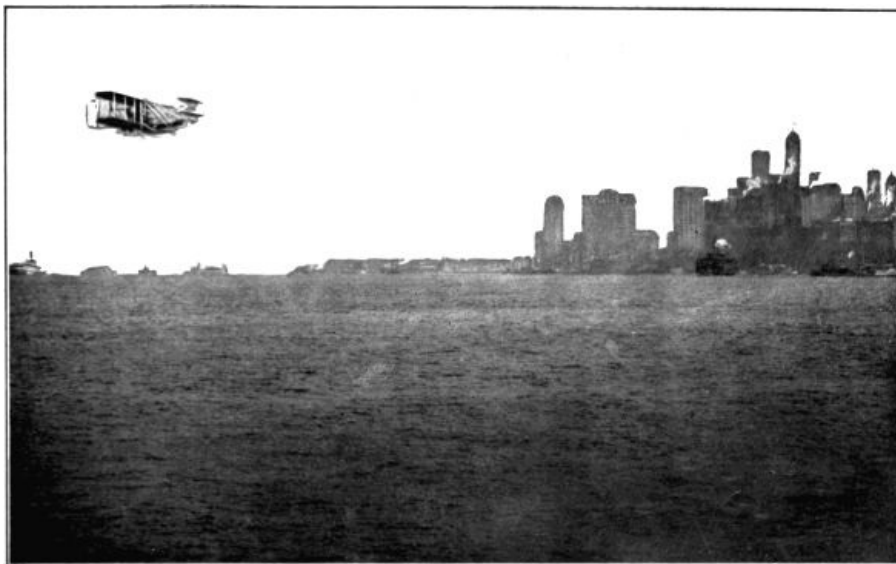

Mr. Wilbur Wright flying over New York Harbor, October 4, 1909.

In time, no doubt, flying-machines of quite different types will be invented. Quite possibly the machines of the Wright model will become altogether obsolete. But this can have no possible effect upon the position that the Wright brothers themselves must always hold in the history of scientific progress. The men who fly from New York to San Francisco, or from New York to London, will be carrying out the work of the Dayton pioneers; and no future accomplishment of the heavier-than-air machine can possibly rank in historical importance with that first flight in the presence of witnesses made December 17, 1903. Then and there it was successfully demonstrated that the last difficulty, so far as joining theory and practice was concerned, had been mastered. Potentially, from that moment, the conquest of the air was complete; and the names of the conquerors as all the world knows, and as throughout the future all must remember, are Wilbur and Orville Wright.

APPENDIX

REFERENCE LIST AND NOTES

CHAPTER II

THE HIGHWAY OF THE WATERS

(pp. [77-79](#)). The *Great Eastern*. The quotation is from *Ancient and Modern Ships*, by Sir George C. V. Holmes, K.C.V.O., London, 1906.

CHAPTER III

SUBMARINE VESSELS

(pp. [95, 98](#)). The first submarine. As stated in the text the quotation is from a letter written to Thomas Jefferson by David Bushnell, and published in the *Transactions of the American Philosophical Society* in 1789.

(pp. [104-105](#)). A successful diving boat. The quotation is from *The Naval History of the Civil War*, by Admiral Porter.

CHAPTER IV

THE STEAM LOCOMOTIVE

(pp. [127, 128](#)). George Stephenson's locomotive of 1825. The quotation is from *The History of the First Locomotive in America*, by William H. Brown, New York 1874.

304

CHAPTER VI

THE DEVELOPMENT OF ELECTRIC RAILWAYS

(pp. [179-181](#)). Early experimental railways. The quotation is from the article on "Street and Electric Railways," by Thomas Commerford Martin, in the Special Report of the U. S. Census Office on Street and Electric Railways, Washington, 1905.

CHAPTER IX

NAVIGATING THE AIR

(p. [247](#)). Henson's studies of the flying-machine. The quotation is from *Travels in Space*, by E. Seton Valentine and F. L. Tomlinson, New York, 1902.

CHAPTER X

THE TRIUMPH OF THE AEROPLANE

(p. [275](#)). How the air supports a heavier-than-air mechanism. The quotation is from an article on "The Flying Machine," by Professor S. P. Langley, in *McClure's Magazine* for June, 1897.

(p. [284](#)). Langley's aerodrome. The description is from Professor Langley's own account in *McClure's Magazine*, above cited.

(pp. [289, 290](#)). Experiments of the Wright brothers. The quotation is from an article on "The Wright Brothers' Aeroplane," by Orville and Wilbur Wright, in *The Century Magazine* for September, 1908.

(p. [298](#)). Cross-country flight by French officers. The quotation is from the *Scientific American* of June 18, 1910. This periodical has shown great interest in the new science of aeronautics, and was the first to offer a trophy for long-distance flying—a trophy that was won for the years 1908 and 1909 by Mr. Glenn H. Curtiss. The Wright brothers have declined to compete for prizes; otherwise "records" for cross-country flying and the like would doubtless have advanced even more rapidly than has been the case.



Transcriber's Notes

Punctuation and spelling were made consistent when a predominant preference was found in this book; otherwise they were not changed.

Simple typographical errors were corrected; occasional unbalanced quotation marks retained.

Ambiguous hyphens at the ends of lines were retained.

Text uses both "aerial" and "aërial".

Page [262](#): "representing six thousand words" should be "representing six hundred thousand words".

*** END OF THE PROJECT GUTENBERG EBOOK EVERY-DAY SCIENCE: VOLUME 7. THE CONQUEST OF TIME AND SPACE ***

Updated editions will replace the previous one—the old editions will be renamed.

Creating the works from print editions not protected by U.S. copyright law means that no one owns a United States copyright in these works, so the Foundation (and you!) can copy and distribute it in the United States without permission and without paying copyright royalties. Special rules, set forth in the General Terms of Use part of this license, apply to copying and distributing Project Gutenberg™ electronic works to protect the PROJECT GUTENBERG™ concept and trademark. Project Gutenberg is a registered trademark, and may not be used if you charge for an eBook, except by following the terms of the trademark license, including paying royalties for use of the Project Gutenberg trademark. If you do not charge anything for copies of this eBook, complying with the trademark license is very easy. You may use this eBook for nearly any purpose such as creation of derivative works, reports, performances and research. Project Gutenberg eBooks may be modified and printed and given away—you may do practically ANYTHING in the United States with eBooks not protected by U.S. copyright law. Redistribution is subject to the trademark license, especially commercial redistribution.

START: FULL LICENSE

THE FULL PROJECT GUTENBERG LICENSE
PLEASE READ THIS BEFORE YOU DISTRIBUTE OR USE THIS WORK

To protect the Project Gutenberg™ mission of promoting the free distribution of electronic works, by using or distributing this work (or any other work associated in any way with the phrase “Project Gutenberg”), you agree to comply with all the terms of the Full Project Gutenberg™ License available with this file or online at www.gutenberg.org/license.

Section 1. General Terms of Use and Redistributing Project Gutenberg™ electronic works

1.A. By reading or using any part of this Project Gutenberg™ electronic work, you indicate that you have read, understand, agree to and accept all the terms of this license and intellectual property (trademark/copyright) agreement. If you do not agree to abide by all the terms of this agreement, you must cease using and return or destroy all copies of Project Gutenberg™ electronic works in your possession. If you paid a fee for obtaining a copy of or access to a Project Gutenberg™ electronic work and you do not agree to be bound by the terms of this agreement, you may obtain a refund from the person or entity to whom you paid the fee as set forth in paragraph 1.E.8.

1.B. “Project Gutenberg” is a registered trademark. It may only be used on or associated in any way with an electronic work by people who agree to be bound by the terms of this agreement. There are a few things that you can do with most Project Gutenberg™ electronic works even without complying with the full terms of this agreement. See paragraph 1.C below. There are a lot of things you can do with Project Gutenberg™ electronic works if you follow the terms of this agreement and help preserve free future access to Project Gutenberg™ electronic works. See paragraph 1.E below.

1.C. The Project Gutenberg Literary Archive Foundation (“the Foundation” or PGLAF), owns a compilation copyright in the collection of Project Gutenberg™ electronic works. Nearly all the individual works in the collection are in the public domain in the United States. If an individual work is unprotected by copyright law in the United States and you are located in the United States, we do not claim a right to prevent you from copying, distributing, performing, displaying or creating derivative works based on the work as long as all references to Project Gutenberg are removed. Of course, we hope that you will support the Project Gutenberg™ mission of promoting free access to electronic works by freely sharing Project Gutenberg™ works in compliance with the terms of this agreement for keeping the Project Gutenberg™ name associated with the work. You can easily comply with the terms of this agreement by keeping this work in the same format with its attached full Project Gutenberg™ License when you share it without charge with others.

1.D. The copyright laws of the place where you are located also govern what you can do with this work. Copyright laws in most countries are in a constant state of change. If you are outside the United States, check the laws of your country in addition to the terms of this agreement before downloading, copying, displaying, performing, distributing or creating derivative works based on this work or any other Project Gutenberg™ work. The Foundation makes no representations concerning the copyright status of any work in any country other than the United States.

1.E. Unless you have removed all references to Project Gutenberg:

1.E.1. The following sentence, with active links to, or other immediate access to, the full Project Gutenberg™ License must appear prominently whenever any copy of a Project Gutenberg™ work (any work on which the phrase “Project Gutenberg” appears, or with which the phrase “Project Gutenberg” is associated) is accessed, displayed, performed, viewed, copied or distributed:

This eBook is for the use of anyone anywhere in the United States and most other parts of the world at no cost and with almost no restrictions whatsoever. You may copy it, give it away or re-use it under the terms of the Project Gutenberg License included with this eBook or online at www.gutenberg.org. If you are not located in the United States, you will have to check the laws of the country where you are located before using this eBook.

1.E.2. If an individual Project Gutenberg™ electronic work is derived from texts not protected by U.S. copyright law (does not contain a notice indicating that it is posted with permission of the copyright holder), the work can be copied and distributed to anyone in the United States without paying any fees or charges. If you are redistributing or providing access to a work with the phrase “Project Gutenberg” associated with or appearing on the work, you must comply either with the requirements of paragraphs 1.E.1 through 1.E.7 or obtain permission for the use of the work and the Project Gutenberg™ trademark as set forth in paragraphs 1.E.8 or 1.E.9.

1.E.3. If an individual Project Gutenberg™ electronic work is posted with the permission of the copyright holder, your use and distribution must comply with both paragraphs 1.E.1

through 1.E.7 and any additional terms imposed by the copyright holder. Additional terms will be linked to the Project Gutenberg™ License for all works posted with the permission of the copyright holder found at the beginning of this work.

1.E.4. Do not unlink or detach or remove the full Project Gutenberg™ License terms from this work, or any files containing a part of this work or any other work associated with Project Gutenberg™.

1.E.5. Do not copy, display, perform, distribute or redistribute this electronic work, or any part of this electronic work, without prominently displaying the sentence set forth in paragraph 1.E.1 with active links or immediate access to the full terms of the Project Gutenberg™ License.

1.E.6. You may convert to and distribute this work in any binary, compressed, marked up, nonproprietary or proprietary form, including any word processing or hypertext form. However, if you provide access to or distribute copies of a Project Gutenberg™ work in a format other than “Plain Vanilla ASCII” or other format used in the official version posted on the official Project Gutenberg™ website (www.gutenberg.org), you must, at no additional cost, fee or expense to the user, provide a copy, a means of exporting a copy, or a means of obtaining a copy upon request, of the work in its original “Plain Vanilla ASCII” or other form. Any alternate format must include the full Project Gutenberg™ License as specified in paragraph 1.E.1.

1.E.7. Do not charge a fee for access to, viewing, displaying, performing, copying or distributing any Project Gutenberg™ works unless you comply with paragraph 1.E.8 or 1.E.9.

1.E.8. You may charge a reasonable fee for copies of or providing access to or distributing Project Gutenberg™ electronic works provided that:

- You pay a royalty fee of 20% of the gross profits you derive from the use of Project Gutenberg™ works calculated using the method you already use to calculate your applicable taxes. The fee is owed to the owner of the Project Gutenberg™ trademark, but he has agreed to donate royalties under this paragraph to the Project Gutenberg Literary Archive Foundation. Royalty payments must be paid within 60 days following each date on which you prepare (or are legally required to prepare) your periodic tax returns. Royalty payments should be clearly marked as such and sent to the Project Gutenberg Literary Archive Foundation at the address specified in Section 4, “Information about donations to the Project Gutenberg Literary Archive Foundation.”
- You provide a full refund of any money paid by a user who notifies you in writing (or by e-mail) within 30 days of receipt that s/he does not agree to the terms of the full Project Gutenberg™ License. You must require such a user to return or destroy all copies of the works possessed in a physical medium and discontinue all use of and all access to other copies of Project Gutenberg™ works.
- You provide, in accordance with paragraph 1.F.3, a full refund of any money paid for a work or a replacement copy, if a defect in the electronic work is discovered and reported to you within 90 days of receipt of the work.
- You comply with all other terms of this agreement for free distribution of Project Gutenberg™ works.

1.E.9. If you wish to charge a fee or distribute a Project Gutenberg™ electronic work or group of works on different terms than are set forth in this agreement, you must obtain permission in writing from the Project Gutenberg Literary Archive Foundation, the manager of the Project Gutenberg™ trademark. Contact the Foundation as set forth in Section 3 below.

1.F.

1.F.1. Project Gutenberg volunteers and employees expend considerable effort to identify, do copyright research on, transcribe and proofread works not protected by U.S. copyright law in creating the Project Gutenberg™ collection. Despite these efforts, Project Gutenberg™ electronic works, and the medium on which they may be stored, may contain “Defects,” such as, but not limited to, incomplete, inaccurate or corrupt data, transcription errors, a copyright or other intellectual property infringement, a defective or damaged disk or other medium, a computer virus, or computer codes that damage or cannot be read by your equipment.

1.F.2. LIMITED WARRANTY, DISCLAIMER OF DAMAGES - Except for the “Right of Replacement or Refund” described in paragraph 1.F.3, the Project Gutenberg Literary Archive Foundation, the owner of the Project Gutenberg™ trademark, and any other party distributing a Project Gutenberg™ electronic work under this agreement, disclaim all liability to you for damages, costs and expenses, including legal fees. YOU AGREE THAT YOU HAVE NO REMEDIES FOR NEGLIGENCE, STRICT LIABILITY, BREACH OF WARRANTY OR BREACH OF CONTRACT EXCEPT THOSE PROVIDED IN PARAGRAPH 1.F.3. YOU AGREE THAT THE FOUNDATION, THE TRADEMARK OWNER, AND ANY DISTRIBUTOR UNDER

THIS AGREEMENT WILL NOT BE LIABLE TO YOU FOR ACTUAL, DIRECT, INDIRECT, CONSEQUENTIAL, PUNITIVE OR INCIDENTAL DAMAGES EVEN IF YOU GIVE NOTICE OF THE POSSIBILITY OF SUCH DAMAGE.

1.F.3. LIMITED RIGHT OF REPLACEMENT OR REFUND - If you discover a defect in this electronic work within 90 days of receiving it, you can receive a refund of the money (if any) you paid for it by sending a written explanation to the person you received the work from. If you received the work on a physical medium, you must return the medium with your written explanation. The person or entity that provided you with the defective work may elect to provide a replacement copy in lieu of a refund. If you received the work electronically, the person or entity providing it to you may choose to give you a second opportunity to receive the work electronically in lieu of a refund. If the second copy is also defective, you may demand a refund in writing without further opportunities to fix the problem.

1.F.4. Except for the limited right of replacement or refund set forth in paragraph 1.F.3, this work is provided to you 'AS-IS', WITH NO OTHER WARRANTIES OF ANY KIND, EXPRESS OR IMPLIED, INCLUDING BUT NOT LIMITED TO WARRANTIES OF MERCHANTABILITY OR FITNESS FOR ANY PURPOSE.

1.F.5. Some states do not allow disclaimers of certain implied warranties or the exclusion or limitation of certain types of damages. If any disclaimer or limitation set forth in this agreement violates the law of the state applicable to this agreement, the agreement shall be interpreted to make the maximum disclaimer or limitation permitted by the applicable state law. The invalidity or unenforceability of any provision of this agreement shall not void the remaining provisions.

1.F.6. INDEMNITY - You agree to indemnify and hold the Foundation, the trademark owner, any agent or employee of the Foundation, anyone providing copies of Project Gutenberg™ electronic works in accordance with this agreement, and any volunteers associated with the production, promotion and distribution of Project Gutenberg™ electronic works, harmless from all liability, costs and expenses, including legal fees, that arise directly or indirectly from any of the following which you do or cause to occur: (a) distribution of this or any Project Gutenberg™ work, (b) alteration, modification, or additions or deletions to any Project Gutenberg™ work, and (c) any Defect you cause.

Section 2. Information about the Mission of Project Gutenberg™

Project Gutenberg™ is synonymous with the free distribution of electronic works in formats readable by the widest variety of computers including obsolete, old, middle-aged and new computers. It exists because of the efforts of hundreds of volunteers and donations from people in all walks of life.

Volunteers and financial support to provide volunteers with the assistance they need are critical to reaching Project Gutenberg™'s goals and ensuring that the Project Gutenberg™ collection will remain freely available for generations to come. In 2001, the Project Gutenberg Literary Archive Foundation was created to provide a secure and permanent future for Project Gutenberg™ and future generations. To learn more about the Project Gutenberg Literary Archive Foundation and how your efforts and donations can help, see Sections 3 and 4 and the Foundation information page at www.gutenberg.org.

Section 3. Information about the Project Gutenberg Literary Archive Foundation

The Project Gutenberg Literary Archive Foundation is a non-profit 501(c)(3) educational corporation organized under the laws of the state of Mississippi and granted tax exempt status by the Internal Revenue Service. The Foundation's EIN or federal tax identification number is 64-6221541. Contributions to the Project Gutenberg Literary Archive Foundation are tax deductible to the full extent permitted by U.S. federal laws and your state's laws.

The Foundation's business office is located at 809 North 1500 West, Salt Lake City, UT 84116, (801) 596-1887. Email contact links and up to date contact information can be found at the Foundation's website and official page at www.gutenberg.org/contact

Section 4. Information about Donations to the Project Gutenberg Literary Archive Foundation

Project Gutenberg™ depends upon and cannot survive without widespread public support and donations to carry out its mission of increasing the number of public domain and licensed works that can be freely distributed in machine-readable form accessible by the widest array of equipment including outdated equipment. Many small donations (\$1 to \$5,000) are particularly important to maintaining tax exempt status with the IRS.

The Foundation is committed to complying with the laws regulating charities and charitable donations in all 50 states of the United States. Compliance requirements are not uniform and it takes a considerable effort, much paperwork and many fees to meet and keep up with these

requirements. We do not solicit donations in locations where we have not received written confirmation of compliance. To SEND DONATIONS or determine the status of compliance for any particular state visit www.gutenberg.org/donate.

While we cannot and do not solicit contributions from states where we have not met the solicitation requirements, we know of no prohibition against accepting unsolicited donations from donors in such states who approach us with offers to donate.

International donations are gratefully accepted, but we cannot make any statements concerning tax treatment of donations received from outside the United States. U.S. laws alone swamp our small staff.

Please check the Project Gutenberg web pages for current donation methods and addresses. Donations are accepted in a number of other ways including checks, online payments and credit card donations. To donate, please visit: www.gutenberg.org/donate

Section 5. General Information About Project Gutenberg™ electronic works

Professor Michael S. Hart was the originator of the Project Gutenberg™ concept of a library of electronic works that could be freely shared with anyone. For forty years, he produced and distributed Project Gutenberg™ eBooks with only a loose network of volunteer support.

Project Gutenberg™ eBooks are often created from several printed editions, all of which are confirmed as not protected by copyright in the U.S. unless a copyright notice is included. Thus, we do not necessarily keep eBooks in compliance with any particular paper edition.

Most people start at our website which has the main PG search facility: www.gutenberg.org.

This website includes information about Project Gutenberg™, including how to make donations to the Project Gutenberg Literary Archive Foundation, how to help produce our new eBooks, and how to subscribe to our email newsletter to hear about new eBooks.