

The Project Gutenberg eBook of Records of Steam Boiler Explosions, by Edward Bindon Marten

This ebook is for the use of anyone anywhere in the United States and most other parts of the world at no cost and with almost no restrictions whatsoever. You may copy it, give it away or re-use it under the terms of the Project Gutenberg License included with this ebook or online at www.gutenberg.org. If you are not located in the United States, you'll have to check the laws of the country where you are located before using this eBook.

Title: Records of Steam Boiler Explosions

Author: Edward Bindon Marten

Release date: December 23, 2014 [EBook #47762]

Language: English

Credits: Produced by Chris Curnow, Martin Mayer and the Online Distributed Proofreading Team at <http://www.pgdp.net> (This file was produced from images generously made available by The Internet Archive)

*** START OF THE PROJECT GUTENBERG EBOOK RECORDS OF STEAM BOILER EXPLOSIONS ***

[A [transcriber's note](#) follows the text.]

RECORDS
OF
**STEAM BOILER
EXPLOSIONS,**

BY
EDWARD BINDON MARTEN,

MEM. INST. OF MECHANICAL ENGINEERS; ASSOCIATE OF INSTITUTION OF CIVIL ENGINEERS, AND CHIEF
ENGINEER TO THE MIDLAND STEAM BOILER INSPECTION AND ASSURANCE CO.

LONDON;
E. & F. N. SPON, 48, CHARING CROSS.

STOURBRIDGE:
R. BROOMHALL, 148, HIGH STREET.

1872.

CONTENTS

[PREFACE.](#)

[ON STEAM BOILER EXPLOSIONS](#)

[CONCLUSIONS](#)

[BOILER EXPLOSIONS IN 1866.](#)

[BOILER EXPLOSIONS IN 1867.](#)

[BOILER EXPLOSIONS IN 1868.](#)

[BOILER EXPLOSIONS IN 1869.](#)

[BOILER EXPLOSIONS IN 1870.](#)

[BOILER EXPLOSIONS IN 1871.](#)

PREFACE.

Accurate information as to Boiler Explosions must always be useful to those who are interested in the safe working of Steam Boilers.

The following pages contain very brief abstracts of records obtained for the Midland Steam Boiler Inspection and Assurance Company, by whose permission they are now republished in a compact and convenient form.

By permission of the Council of the Institution of Mechanical Engineers, the records are prefaced by a Paper on Steam Boiler Explosions and their records, and on Inspection as a means of prevention, read before that Institution at Manchester, August 1st, 1866, and a further Paper on the "Conclusions derived from the experience of recent Steam Boiler Explosions," read before the same Institution at Nottingham, August 3rd, 1870.

All names of Works or Firms are omitted from the records as unnecessary.

On Steam Boiler Explosions

AND THEIR RECORDS, AND ON, INSPECTION AS A MEANS OF PREVENTION, BY EDWARD B. MARTEN, MEM. INST. M.E. A.I.C.E., EXCERPT MINUTES OF PROCEEDINGS OF THE MEETING OF THE INSTITUTION OF MECHANICAL ENGINEERS, AT MANCHESTER, 1ST AUGUST, 1866, JOSEPH WHITWORTH, ESQ., PRESIDENT, IN THE CHAIR. BY PERMISSION OF THE COUNCIL.

The subject of Steam Boiler Explosions, which was brought before this Institution in June, 1848, in a paper by the late Mr. William Smith of Dudley in reference to an explosion near that place, and again in 1859 in a paper by Mr. Longridge on the economy and durability of stationary boilers, is one of great importance and is now attracting increased attention. The first public notice of the subject was by a parliamentary committee in 1817, which was appointed in consequence of a very fatal boiler explosion in London in 1815; evidence was then collected as to steamboats, and many boiler explosions were referred to. That committee recommended among other things that boilers should be made of wrought iron, instead of cast iron or copper, which had been the materials mainly used previously; that they should be inspected and tested; and that there should be two safety valves, each loaded to one third of the test pressure, under penalties for any excess. A great part of the information now existing upon the subject, especially in regard to the earlier explosions, is to be found in the records of inquests after fatal cases; and some of the careful reports of eminent engineers on those occasions have materially assisted in the formation of correct views as to the causes of explosion. Latterly also the printed reports of the inspectors of mines, and more especially the reports of the explosions of locomotives, illustrated by diagrams by the inspectors of railways, have furnished very valuable information. Since the subject has been taken up by private associations for the prevention of explosions, many more records have been published, although their usefulness is much impaired by their not containing the names of the places whereby the explosions could be identified.

When the writer's attention was first directed to this subject, he met with great difficulty in obtaining correct records of boiler explosions, from which to arrive at the results of past experience; and wishing to base his own opinion on facts, rather than on the inferences of others however reliable, he followed the example of the Franklin Institute in their elaborate investigation of the subject, and collected all the records he could find; and by way of facilitating reference, arranged an index, a manuscript copy of which is presented with the present paper to the Library of this Institution. All must be agreed as to the importance of reliable information on such accidents as boiler explosions; and the writer would suggest that this Institution may materially aid in obtaining the desired records and placing them within easy access, by becoming the depository of reports on explosions, and by inducing those who have the opportunity to forward copies of reports, that these may be arranged so as to be easily found and consulted. It is very desirable that these reports should as far as possible be illustrated by sketches, as aids to the description; and also by slight models like those now shown to the meeting, by which the whole matter may be seen at a glance. So few persons comparatively have the opportunity of examining boilers after explosion, that the most erroneous ideas have prevailed, and theories have been advanced which would soon be dissipated by practical experience or by reading accurate reports. It would also very much aid in the understanding of published matter on the subject, if full descriptions of each case alluded to in illustration could be obtained. These records are as useful to the engineer as the "precedents" or "cases" to the lawyer or the surgeon. After any serious explosion, the newspapers of the neighbourhood in which it has occurred contain voluminous articles describing the disastrous result and the damage done, which, although useful as far as they go, do not in the least assist in arriving at the cause of explosion. The really important particulars, such as the description and construction of the boiler, its dimensions, and the pressure at which it worked, are in most cases omitted altogether.

The record of explosions presented to the Institution contains a list of the boiler explosions in each year of the present century, as far as known to the writer, with the names of the places, and the description and sizes of the boilers, and the supposed cause of explosion, together with references to the books or papers from which further information may be obtained. Of course many of the explosions have to be put down as uncertain in some of the particulars; but every year improves the record, as fresh information is obtained, and with the assistance of the members of this Institution it might be made far more perfect and extensive.

The total number of explosions here recorded is 1046, and they caused the death of 4076 persons and the injury of 2903. The causes assigned for the several explosions are very numerous, and are no doubt incorrect in many cases; but they may be generally stated as follows:

397 are too uncertain to place under any heading; but of the rest

145 were from the boilers being worn out, or from corrosion, or from deteriorated plates or rivets.
 137 from over pressure, from safety valves being wedged or overweighted, in some cases intentionally, or from other acts of carelessness.
 125 from faulty construction of boiler or fittings, want of stays, or neglect of timely repair.
 119 from collapse of internal tubes, generally from insufficient strength.
 114 from shortness of water, or from scurf preventing the proper contact of the water with the plates; or from improper setting so as to expose the sides of the boiler to the flame above the water line.
 9 from extraneous causes, such as effect of lightning striking down the stacks upon the boilers, or from fire in the building or explosion of gas in the flues.
1046 total number of explosions.

The exploded boilers were of the following descriptions:—

232 are not sufficiently described to place under any head; but of the rest
 320 were Marine boilers of various forms.
 141 were Cornish, Lancashire, or other boilers internally fired.
 120 were Locomotive, or other multitubular boilers.
 116 were plain Cylindrical boilers, externally fired.
 64 were Balloon or haystack, wagon, Butterley, British-tube, elephant, or Trevithick boilers.
 29 were Portable, agricultural, upright, or crane boilers.
 14 were Heating apparatus or kitchen boilers.
 10 were Upright boilers attached to puddling or mill furnaces at ironworks.
1046 total number of explosions.

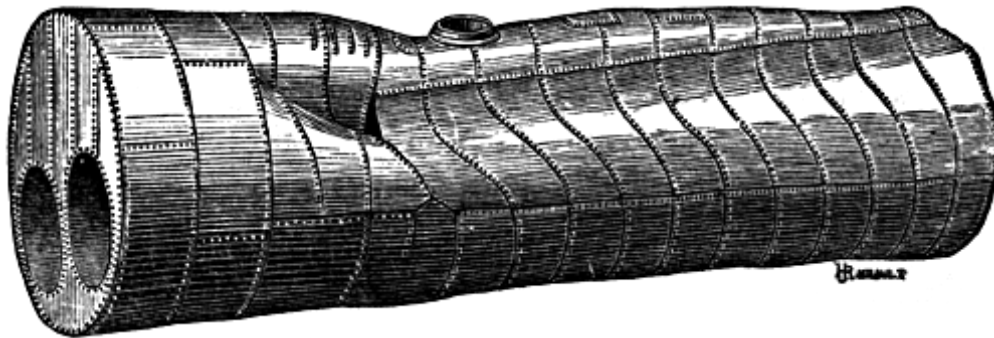

Fig. 1.

The theories as to the causes of explosion have been numerous. In the early days of the steam engine, when the steam was used only as a condensing medium and the pressure in the boiler was frequently allowed to get below atmospheric pressure, many boilers were destroyed by the excess of the external atmospheric pressure becoming too great, causing them to be collapsed or crumpled up; and this led to the use of the atmospheric valve still found on old boilers. Even so lately as last year, 1865, a boiler in the neighbourhood of Bury, Lancashire, has suffered in this way by collapse from external pressure; its appearance after the accident is shown in [Fig. 1](#), which is copied from a photograph.



Fig. 2.

The early explosions were so palpably due to the weakness of the boilers, which compared with those of the present day were most ill constructed, that no one thought of any other cause than the insufficient strength of the vessel to bear the expansive force of the steam contained in it. When the advantages of high-pressure steam became recognized, and the boilers were improved so as to bear the increased strain, the tremendous havoc caused by an explosion led many to think that something more must be required than the expansive force of the steam to produce such an effect; and they appear to have attributed to steam under certain conditions a detonating force, or a sudden access of expansive power that overcame all resistance. To support this somewhat natural supposition, it was asserted that the steam became partially decomposed into its constituent gases, forming an explosive mixture within the boiler. That this belief is still sometimes entertained is seen from the verdict of a jury even in the present year, 1866, in the case of the explosion of a plain cylindrical boiler at Leicester, shown in [Fig. 2](#), the real cause of which appears to have been that the shell of the boiler was weakened by the manhole. It seems hardly necessary to point out the fallacy of imagining decomposition and recombination of the steam to take place in succession in the same vessel without the introduction of any new element for causing a change of chemical combination; but it is necessary to refer to this supposition, as the idea is shown to be not yet extinct.

Again it has been asserted that the steam when remaining quite still in the boiler becomes heated

much beyond the temperature due to the pressure; and that therefore when it is stirred or mixed or brought more in contact with the water by the opening of a valve or other cause, the water evaporates so rapidly as to produce an excessive pressure by accumulation of steam. In support of this view the frequency of explosions upon the starting of the engine after a short stand is added; but it is very doubtful whether by this means a sufficient extra pressure could be produced to cause an explosion, unless the boiler had been previously working up to within a very small margin of its strength. Explosions are seldom caused by a sudden increase of pressure, but rather by the pressure gradually mounting to the bursting point, when of course the effect is sudden enough. Nor is it necessary in many cases to look for much increase of pressure as the cause of explosion; for it is far more often the case that the strength of the boiler has gradually degenerated by wear or corrosion, until unable to bear even the ordinary working pressure. It is so very easy, when examining the scene of an explosion, for the first cause of rupture to be confounded with the causes of the subsequent mischief, that in many cases erroneous conclusions have been arrived at in this way.

The most important points to find out in connection with any explosion are the condition of the boiler and all belonging to it immediately before the explosion, together with the locality of the first rent, the direction of the line of rupture, and the nature of the fracture; as everything occurring after the instant of the first rent is an effect and not a cause of explosion. As soon as the first rent has taken place, the balance of strain in the fabric is disturbed, and therefore the internal pressure has greatly increased power in continuing the rupture; and also the pressure being then removed from the surface of the water, which is already heated to the temperature of the steam, the whole body of the water gives out its heat in the form of steam at a considerable pressure, and thus supplies the volume of steam for carrying on the work of destruction. When thus quickly generated, the steam perhaps carries part of the water with it in the same way that it does in ordinary priming; and it has been thought by some that the impact of the water is thus added to that of the steam, to aid in the shock given to all surrounding obstacles.

It is seldom that one out of a bed of boilers explodes without more or less injury to the others on either side of it; but sometimes two boilers in one bed, or three, or even five, have exploded simultaneously.

The causes of boiler explosions may be considered under the two general heads of—

Firstly, faults in the fabric of the boiler itself as originally constructed, such as bad shape, want of stays, bad material, defective workmanship, or injudicious setting:—and

Secondly, mischief arising during working, either from wear and tear, or from overheating through shortness of water or accumulation of scurf; or from corrosion, in its several forms of general thinning, pitting, furrowing, or channelling of the plates; or from flaws or fractures in the material, or injury by the effect of repeated strain; or from undue pressure through want of adequate arrangements for escape of surplus steam.

There is no doubt that many of the early explosions were from faults of construction. The stronger materials now used were then found so difficult to manipulate that others easier to work were chosen, and often the shape of the boiler was only selected as the one easiest to make. The early boilers were made of copper or cast iron, with leaden or even wooden tops, and of the weakest possible shape. Such was the boiler used by Savery, shown in [Fig. 3](#), and the Tun Boiler and Flange boiler, [Fig. 4](#) and [Fig. 5](#). The very fatal explosion in London in 1815, referred to by the parliamentary commission previously named, was of a cast-iron boiler, which failed because one side was too thin to bear the pressure, as the casting was of irregular thickness. The steam being at that time used only at or below atmospheric pressure as a means of obtaining a vacuum by condensation for working by the external pressure of the atmosphere, so little was pressure of the steam thought of, that boilers were proposed and it is believed were actually constructed with hooped wooden shells, like barrels, and internal fireplaces and flues of copper; and even a stone chamber was named as being a suitable shell for a boiler, with internal fireplace and copper flue passing three times the length of the inside and out at the top, like an ordinary stove and piping. These boilers must have been something like the sketches given in [Fig. 6](#) and [Fig. 7](#), and were intended to be exposed only to the external pressure of the atmosphere.

Cast iron was frequently used for the shell of boilers, with an internal fireplace and tubes of wrought iron, as shown in [Fig. 8.](#), and boilers of this construction are still to be



Fig. 3.

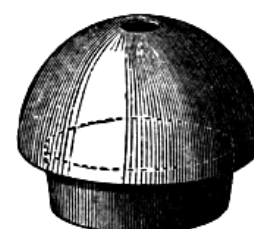

Fig. 4.

found in use at some of the older works at the present day. As the outside shell and front plate are 1½ inch thick and are not exposed to any wear at all, these boilers are sufficiently strong. A duplicate front plate with set of tubes attached is always kept on hand in case of need. Another form of cast-iron boiler is shown in [Fig. 9.](#), made in several parts put together with flange joints, with an internal fireplace and flue also made of cast iron. When cast iron was used for the parts exposed to the fire in boilers intended for high pressure, it was sometimes employed in the form of tubes of small diameter and proportionately thinner; as in Woolf's boiler, so much spoken of in the evidence before the parliamentary committee of 1817. This boiler, shown in [Fig. 10.](#), consisted of nine cast-iron pipes, about 1 foot diameter and 9 feet long, set in brickwork so that the flame played all round them. These small tubes were connected with another of larger size placed transversely above them, forming a steam receiver, and this again with a still larger one, which formed a steam chamber. No details of any explosions of the three last mentioned boilers have been obtained; but it is known that the cast iron was found a most treacherous material, especially when exposed to the action of the fire; and that the effect of explosion was very disastrous, because the boiler burst at once into many pieces, each of which was driven out with great velocity, and the danger was not mitigated by the circumstance of large masses holding together, as is found to be the case with wrought-iron boilers when exploded.



Fig. 5.

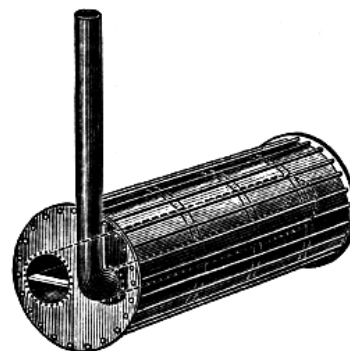

Fig. 6.

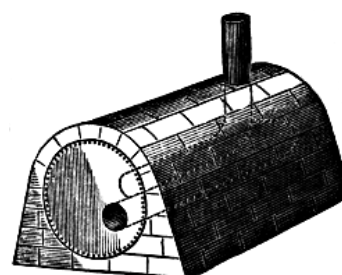

Fig. 7.

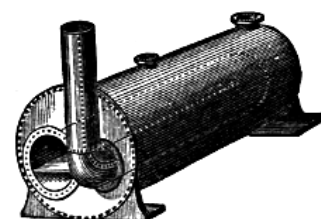

Fig. 8.

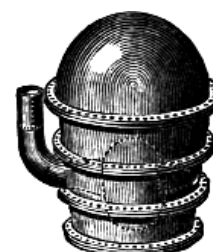

Fig. 9.

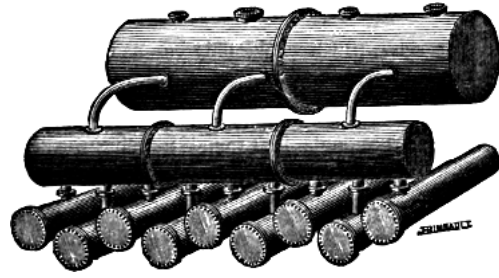

Fig. 10.

When wrought-iron boilers came into use the shapes were most varied, and the dimensions much larger than before. One of the earliest was the Wagon boiler, shown in [Fig. 11.](#), with round top and plain flat sides, which could only be made to bear even the smallest pressure by being strengthened with numerous stays. In most cases of explosion of this class of boiler the bottom was torn off, owing to the angle iron round it being weakened by the alternate bending backwards and forwards under each variation of pressure, as all the sides and the bottom must be constantly springing when at work. Such was the explosion at Chester in 1822, and many others. This shape was soon improved in its steam generating powers by making the sides concave instead of flat, as shown in [Fig. 12.](#), so that the heating surface was greater and also in a better position to receive the heat from the flame in the flues. This shape was further elaborated by rounding the ends as in [Fig. 13.](#), and in some cases making the bottom convex to correspond with the top, as in [Fig. 14.](#) All these forms however still required numerous stays to retain them in shape, the safety of the boiler being dependent upon the stays; and numerous explosions show the weakness of these boilers. They generally gave way at the bottom, as in an explosion that occurred at Manchester in 1842, where the boiler had been weakened by frequent patching; they also sometimes exploded through the failure of the stays.

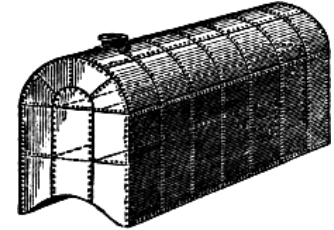

Fig. 11.

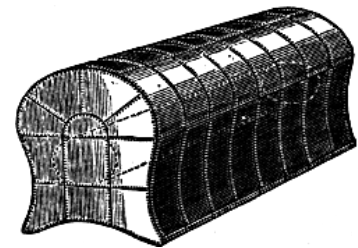

Fig. 12.

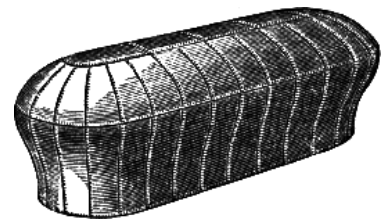

Fig. 13.

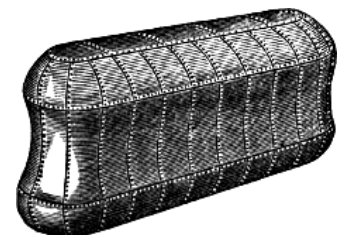

Fig. 14.

A very early improvement in the right direction consisted in making the shell circular; and some few large boilers still exist that were made completely spherical, as show in [Fig. 15.](#), so that the whole of the iron was exposed to tension only, and required no assistance from stays, and the boiler had no tendency to alter its shape under varying pressure. This shape however had the great disadvantage of possessing the least amount of heating surface for its size or cubic contents; and also it was very liable to injury from sediment on the bottom, which accumulated on the most central spot. The spherical form was therefore soon modified into the shape shown in [Fig. 16.](#) by making the bottom more shallow, although still convex; and afterwards by putting flat or concave sides and a flat or concave bottom, with the angle constructed either of bent plates or angle iron, as in [Fig. 17](#) and [Fig. 18](#), which represent the forms known so well in the Staffordshire district as the common Balloon or Haystack boiler. Many of these have been made of very great size, measuring as much as 20 feet diameter, and containing so much water and steam as to be most formidable magazines for explosion. Perhaps no form of boiler has exploded more than this, partly because of the great number that have been used, but chiefly because of the inherent weakness of the shape. The records however have not been obtained of the great majority of these explosions, because they seldom caused sufficient damage or loss of life to attract much attention, as these boilers generally worked in isolated positions at collieries. The bottom is only prevented from blowing down into the fireplace by numerous stays from the top, and the angle iron round the bottom of the sides is much tried by the constant springing of the

plates under every alternation of pressure; and the weakness thus occasioned is increased by the angle resting on the brickwork and being exposed to corrosion. The effect of this continued alternation of strain is well shown by the elastic model exhibited.

Notwithstanding the dependence of these boilers upon stays for their strength, many have been made as large as 12 and 15 feet diameter without stays; and explosion sooner or later has been the consequence. Such was an explosion that took place at Smethwick in 1862, which is shown in [Fig. 19](#). As the force of the explosion was only slight, the effect of the bottom giving way, and the consequent rolling over caused by the reaction of the issuing steam and water, is clearly seen. Another example that occurred at Wednesbury in 1862 is shown in [Fig. 20](#), where the explosion was rather more violent, the bottom of the boiler being torn off all round and left upon the firegrate, and rent nearly into two pieces; while the top and sides were thrown some height in one mass, and were only put out of shape by the fall. The weakness of this boiler had been further increased by making the bottom angle of angle iron, as shown enlarged in [Fig. 21](#), with a ring of flat plate **A** interposed between the angle-iron ring and the concave bottom of the boiler; so that all the effect of the springing of the bottom, as shown by the dotted lines, was thrown upon the angle iron, which was accordingly found cut off all round. Had the concave bottom been made to rise direct from the angle iron, as in [Fig. 22](#), the springing could not have been so great, and the angle iron would only have had to stand the shearing strain of retaining in its place the rigid bottom; but as about one foot all round the bottom was flat, and the concavity was only in the central part, the angle-iron ring had to bear an up and down strain, as shown by the dotted lines in [Fig. 21](#), and the bending action was more severe than it would have been if the bottom had even been made quite flat all over.

A further form of the Balloon boiler is shown in [Fig. 23](#), where the heating surface of the bottom is increased by an internal central dome-shaped fireplace, with an arched and curved flue conducting the flame through one revolution within the boiler before passing again round the outside. This construction however must necessarily have diminished the strength of the boiler greatly. In the drawing the top of the boiler, as indicated by the dotted lines, is removed to show the interior.

The desire to add to the strength of boilers by lessening the diameter of the shell led to the construction of the Plain Cylindrical boilers. They were made first with flat ends of cast iron, which frequently cracked and gave way when exposed to the fire, as described in many of the early American explosions. The flat ends when made of wrought iron, as shown in [Fig. 24](#), are exposed to the same strain as the bottom of the balloon and wagon boilers, and are constantly springing with variation of pressure like drum heads, causing injury to the angle-iron joint. They also require long stays through them to hold in the ends, and these are subject to so much vibration that they seldom continue sound for long together, especially when joined with forked ends and cotters.



Fig. 15.



Fig. 16.

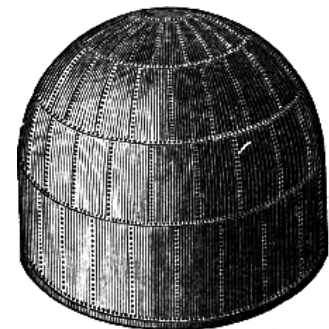

Fig. 17.

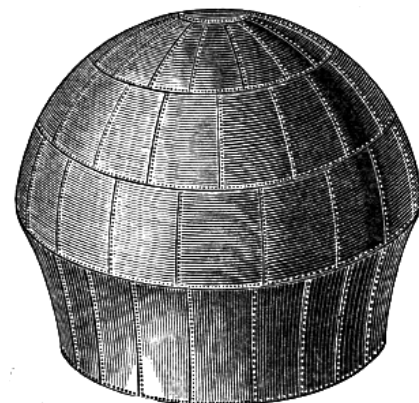

Fig. 18.

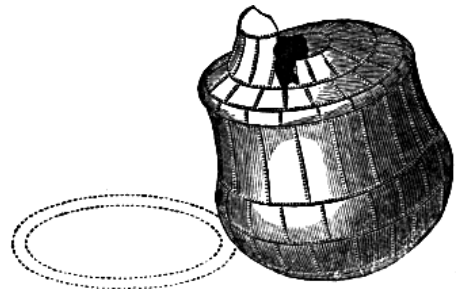

Fig. 19.

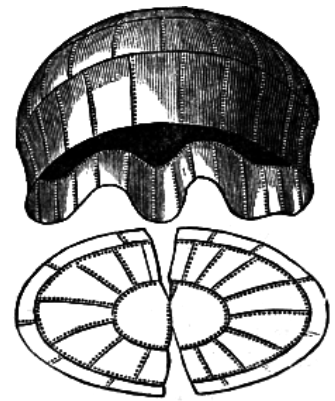

Fig. 20.

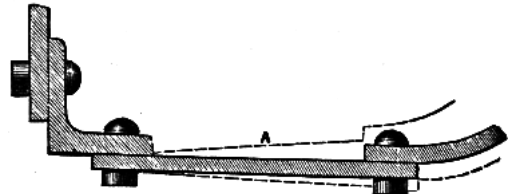

Fig. 21.

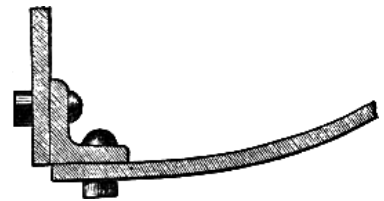

Fig. 22.

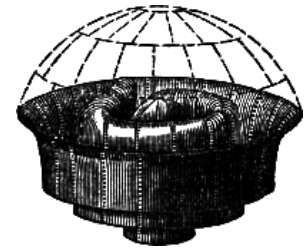

Fig. 23.

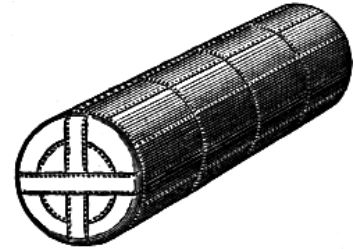

Fig. 24.

As the flat ends of such boilers are always being sprung by each alternation of pressure into a more or less spherical shape, as shown by the elastic model exhibited, this consideration no doubt led to the ends being made hemispherical, as shown in [Fig. 25](#); and plain cylindrical boilers with these hemispherical ends are now so commonly used that they far outnumber any other form of boiler. Their shape renders them very strong, as the whole of the iron is in simple tension, and internal pressure has no tendency to alter the shape, as is shown by the elastic model exhibited. There is one circumstance very much in favour of the plain cylindrical boilers, and that is that they can be so easily cleaned and repaired, as a man can stand properly at his

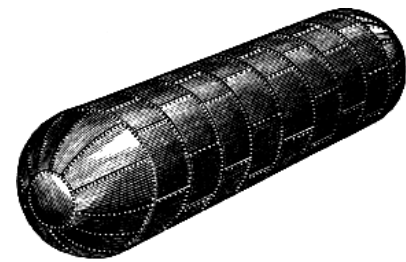

Fig. 25.

work at every part and the whole of the interior surface is exposed equally to view. They are of course exposed to all the evils of boilers externally fired, the part under greatest strain being weakened by the action of the fire; and the bottom is also exposed to injury from accumulation of mud and chips of scurf, which cannot be prevented from falling there, and lying upon the part exposed to the direct action of the fire. When made of great length, such as 70 or 80 feet, as is the practice for applying the waste gas from blast furnaces, these boilers are also liable to seam-rips or "broken backs," owing to the greater expansion of the bottom exposed to the fierce flame for its whole length, than of the top which is kept cooler by exposure to the air; and it would therefore be better to have a succession of short boilers, rather than only a single one, where great length is required.

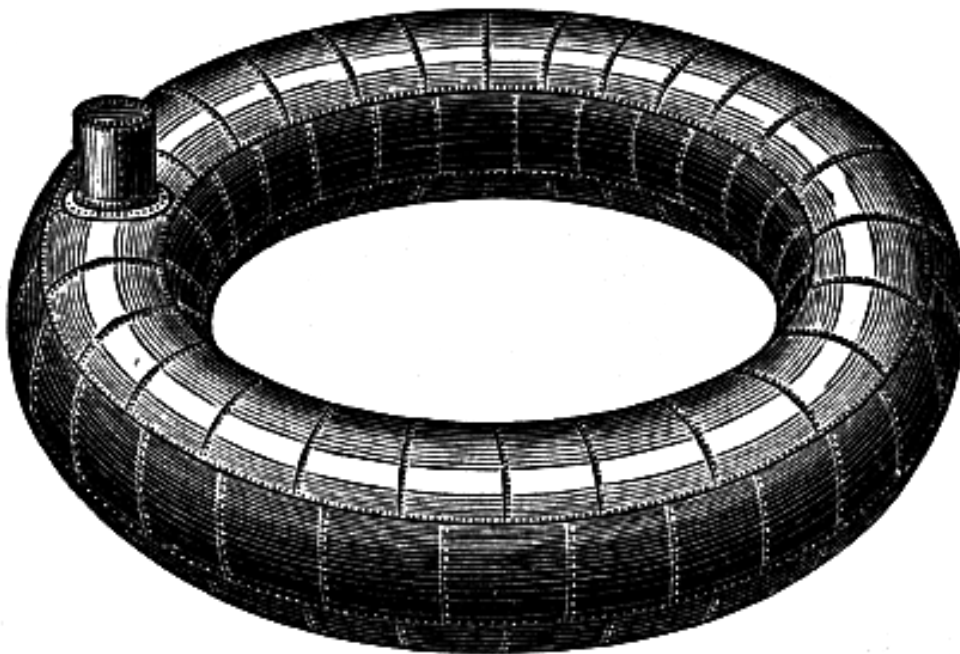

Fig. 26.

One boiler has been seen by the writer where extreme length was avoided by curling the boiler round until the ends met forming a Ring or Annular boiler. This boiler is shown in [Fig. 26](#), and is 5 feet diameter with 25 feet external diameter of the ring, or a mean length of about 63 feet; it has been found to work well for some years, although exposed to the heat of six puddling furnaces.

Explosions of plain cylindrical boilers have been very frequent indeed, although they have not caused a proportionate number of deaths, because they work usually in isolated positions at colliery and mine engines. The sketch shown in [Fig. 27](#), represents an explosion that occurred at Darlaston in 1863, and illustrates the way in which these boilers usually explode. They generally open first at a longitudinal seam over the fire, which has become deteriorated by accumulations of scurf preventing proper contact of the water, so that the plates become overheated, their quality injured, their edges cracked or burnt, and the rivets drawn or loosened. The rent generally continues in the longitudinal direction to the sound seam beyond the bridge at the one end, and at the other end to the seam joining the front end to the shell; and then runs up each of the transverse seams, allowing the rent part of the shell to open out flat on both sides, and liberating both ends of the boiler, which fly off in opposite directions. Of course it is seldom that an explosion is quite so simple as this, as the direction of the flight of the various pieces is so much influenced by the last part that held in contact with the main body of the boiler. The want of due observation of this point has often led to erroneous conclusions.

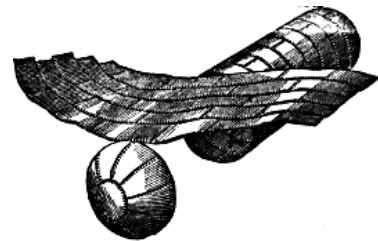

Fig. 27.

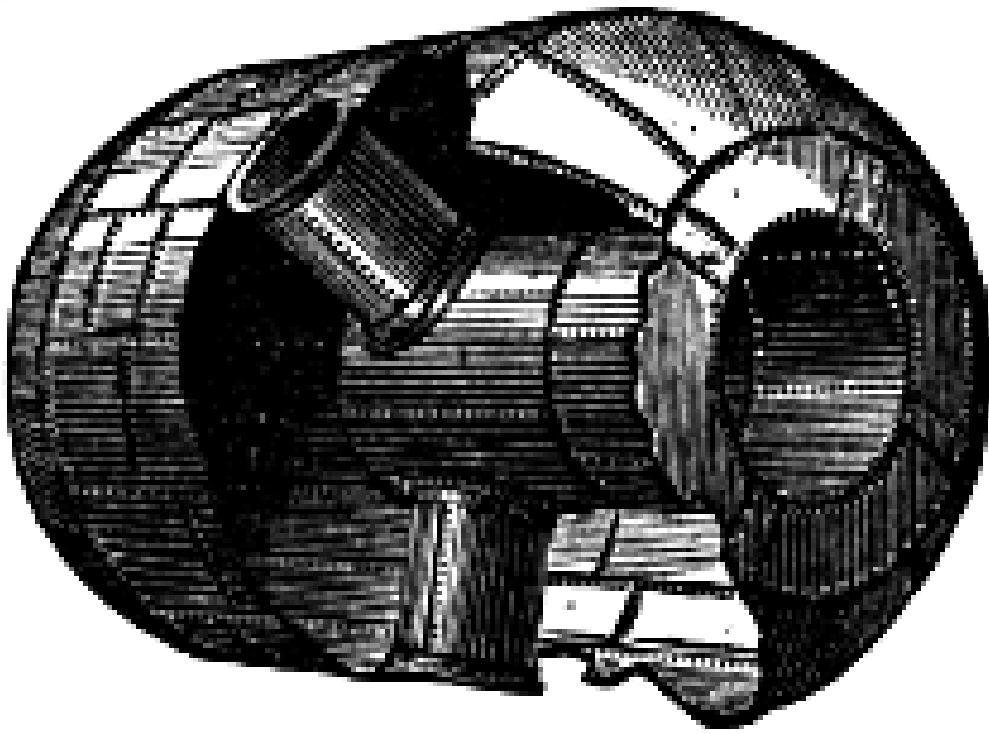

Fig. 28.

In the explosion shown in [Fig. 28](#), and in the model exhibited, which occurred at Westbromwich in 1864, the lower part of the side of an upright boiler was blown out; and the liberated part was also divided into two pieces, each of which fell some distance behind the boiler, in an opposite direction to the side from which they came. The explanation of this became obvious on examination, as the cause of the rupture had been the corrosion of the bottom, and the rent had run up the seams until it met the angle iron of the side tubes, round which it ran to the first seam above. This seam acted as a hinge on which the ruptured pieces turned, and they swung round so violently that they were wrenched off, but not before they had pulled the boiler over and received the diverting force which gave them their direction, for they flew off at a tangent, to the circle in which they had swung round on the sound upper seam as upon a hinge.

In order to avoid having a large diameter for plain cylindrical boilers, especially where exposed to the fire, boilers have been used that have supplied the required steam power by a combination of several cylinders of small diameter. One of these known as the Elephant boiler, has been so much used in France that it is sometimes called the French boiler; it is shown in [Fig. 29](#), and consists of two cylinders of small diameter connected by upright conical tubes to a large cylinder above. Another form called the Retort Boiler, shown in [Fig. 30](#), has been described at a previous meeting of this Institution (see Proceedings Inst. M. E. 1855 page 191). The disadvantages of these two combinations of plain cylinders are that they are not easy to clean or examine internally, and also there is not free exit for the steam, which has to find its way along small channels, and carries the water away with it, causing priming, and also retarding the generation of steam and endangering the boiler plates. With a view to strengthen the plain cylinder made of wrought-iron plates, the seams are sometimes made to run diagonally, as shown in [Fig. 31](#), on the principle that, as the longitudinal is the weakest seam and the transverse the strongest, a diagonal between them gives the greatest amount of strength to the boiler as a whole.

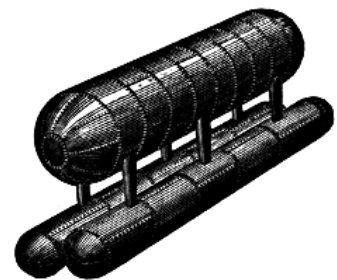

Fig. 29.



Fig. 30.

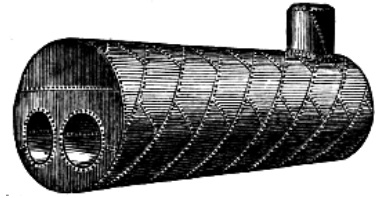

Fig. 31.

Plain cylindrical and wagon boilers have for many years been made with internal tubes of various shapes and arrangement, through which the flame passes to add to the heating surface. These are shown in dotted lines on the previous drawings of wagon boilers, [Fig. 11](#) and [Fig. 12](#). They are also shown in [Fig. 32](#), where a tube passes from over the fire to the front of a plain cylindrical boiler; in [Fig. 33](#) two tubes pass from the sides to the front: in [Fig. 34](#) the tube passes from the back, but returns over the fire and passes again to the back: and in [Fig. 35](#) a tube from the back passes out through a cross tube in each side. The boilers in all these cases are fired externally. This addition of tubes has tended very much to increase the size of these boilers in order to make room for the tubes. These boilers are now found of 9, 10, and even 11 feet diameter; and this large shell being fired externally is exposed to the same dangers as those described in the plain cylindrical boiler, while it is not so easy to keep clean on account of the obstruction offered by the internal flues. When the flame has passed under the whole length of the bottom of these large boilers before going through any tube, it is doubtful whether the heating surface of the tube helps much in the generation of steam; but the tube is of use in reducing the quantity of water in the boiler, as it occupies a considerable space.

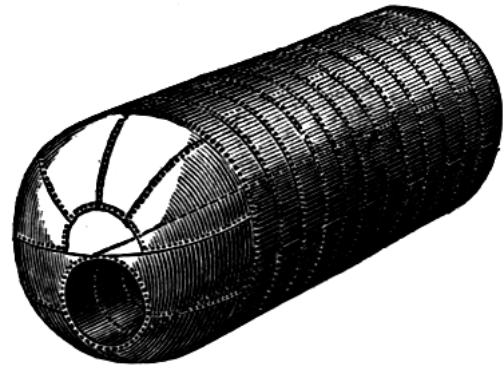

Fig. 32.

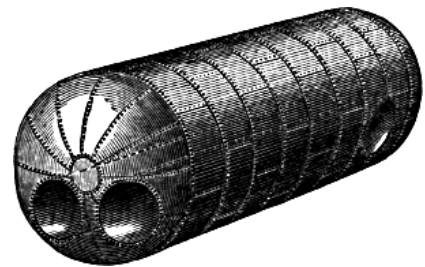

Fig. 33.

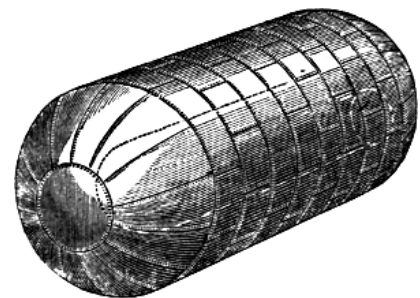

Fig. 34.

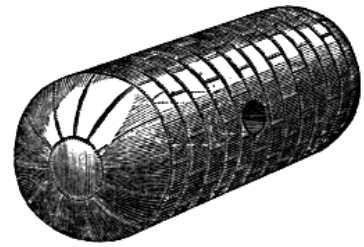

Fig. 35.

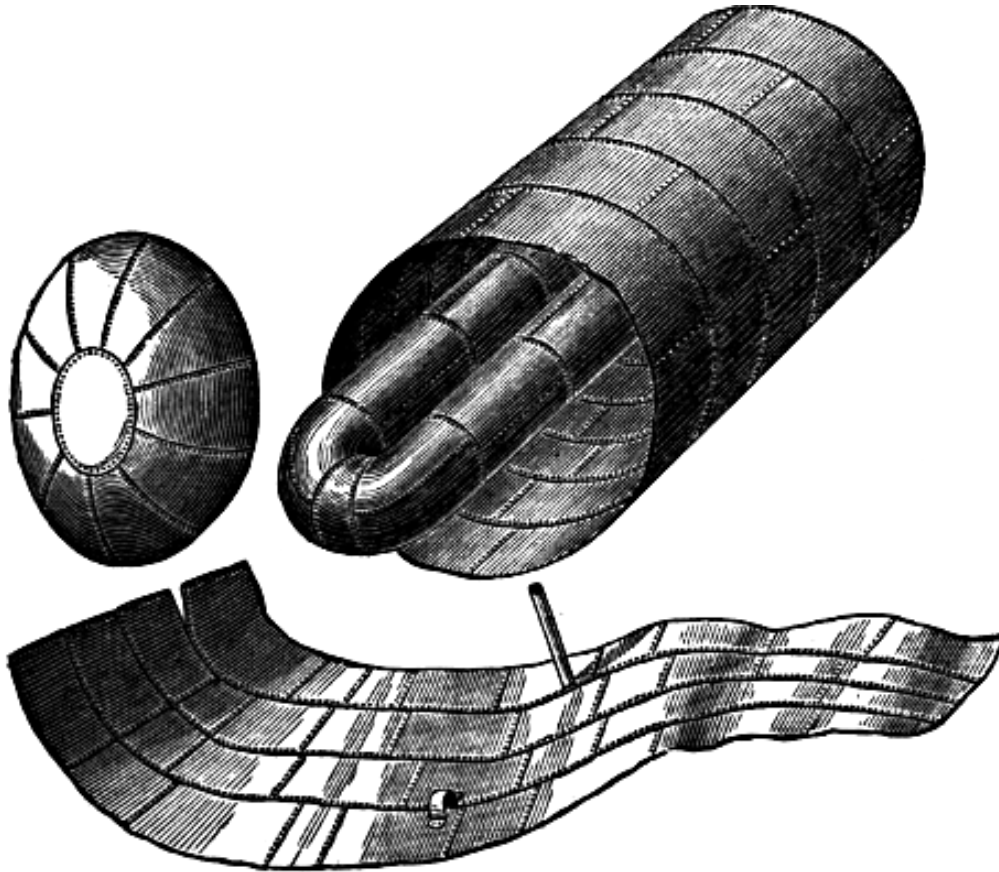

Fig. 36.

Explosions of these boilers have sometimes taken place by collapse of the tubes, but much more generally by the failure of the shell over the fire, as shown in the sketch [Fig. 36](#), representing an explosion that occurred at Wolverhampton in 1865, in which the first rent took place in a seam over the fire where frequent repair had led to a considerable length of longitudinal seam being in one continuous line. The four plates over the fire parted and opened out until they had ripped two seams completely round the boiler; and the plates were thrown in one flat piece, as shown, upon a bank behind. The main body of the boiler with the tubes was turned over, and the front end blown away.

A modification or amalgamation of several of the forms of boilers already mentioned led to the construction known as the Butterley boiler, shown in [Fig. 37](#), with a wagon-shaped end over the fire, continued in a single tube within a plain cylindrical shell beyond. This boiler has been found to generate steam very rapidly; but the extreme weakness of the construction over the fire and along the tube, especially at the part where the front end of the tube widens out in a bell mouth to meet the wagon-topped fireplace, has led to so many explosions that few boilers are now made of this form. A very early explosion that occurred at Edinburgh in 1821 was of a boiler somewhat of this shape, only that the wagon-topped fireplace was much longer. Other explosions of this form of boiler occurred at Ashton-under-Lyne in 1845, at Wolverhampton in 1854, and at Tipton in 1856.

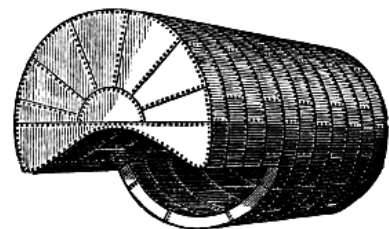

Fig. 37.

The desire to economise fuel led to placing the fire inside the boiler, in a tube running from end to end, as shown in [Fig. 38](#), and the great number of boilers of this form used in Cornwall gave it the name of the Cornish boiler. The exceedingly good duty performed by these boilers led many to believe them the most perfect for economy and durability; but the great number of explosions, or more properly of collapsed flues, that have happened, have altered this opinion, and led to the double-flue boiler shown in [Fig. 39](#), in which not only is the heating surface increased but the strength also, by having two tubes of smaller diameter in the same shell. There are a great many varieties of the two-tube boiler, which have been made for the purpose of obtaining various particular results. In some cases the two tubes have been made to unite into a single tube immediately behind the fires, forming what is known as the Breeches-tube boiler, as shown in [Fig. 40](#), and in other instances the outside shell of the boiler has been made oval, as shown in [Fig. 41](#), with the two tubes continued through from end to end. The heating surface has also been increased, and the strength of the main tubes, by placing smaller transverse tubes across them at right angles; but these advantages are gained by increased complication, leading of course to greater difficulty in examination and repair.

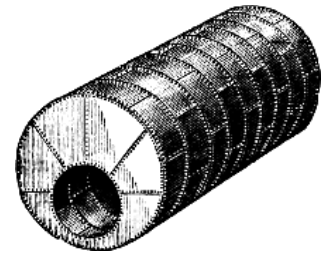

Fig. 38.

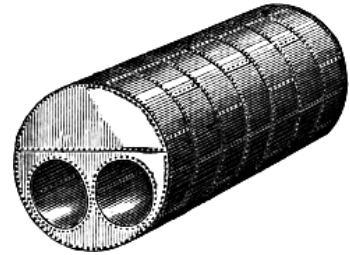

Fig. 39.

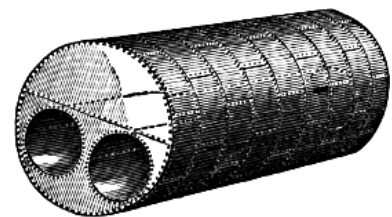

Fig. 40.

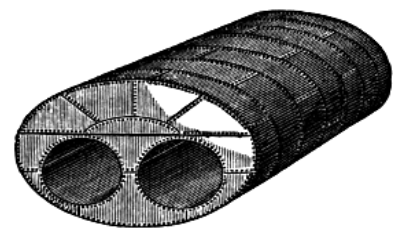

Fig. 41.

The frequent failure of tubes by collapse when used for high pressures, and also the results of careful experiments, led to the simple addition of strengthening rings of different makes around the exterior of these tubes, by which the shell and the tubes are rendered of equal strength. It has taken considerable time for the belief in the weakness of large tubes when exposed to external pressure to become general, and a great many boilers are still made and used having even large tubes without the strengthening rings; and in some districts such boilers are used in great numbers and at far higher pressures than can be considered judicious. In more than one bed of boilers, one boiler after another has exploded by the collapse of the tube from the want of strengthening rings, and yet these have still been believed unnecessary; and the cases of isolated boilers of this construction where the large tubes have collapsed are extremely numerous, yet any other reason than the weakness of the tube has been considered more probable as the cause of explosion. A sketch of a boiler with collapsed flue is given in [Fig. 42](#), which exploded at Burton-on-Trent in 1865; and it is selected from many others because it was a new boiler, well made and mounted, and was a good example of the weakness of a large tube to resist high external

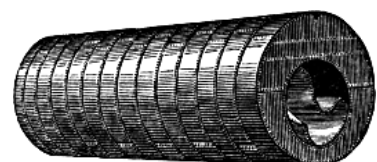

Fig. 42.

pressure when made of great length without the support of strengthening rings.

There are a great many advantages in the tubular boiler internally fired. The shell which is exposed to the greatest tension is not also exposed to the first action of the fire. The fire is in the midst of the water, so that the greatest effect is obtained from it; and the heating surface immediately over the fire, from which most steam is generated, has not so great a depth of water above it for the steam to pass through as in the externally fired boilers heated from the bottom. The tubes also act as stays to the ends; and the mud in the water falls off the tubes, where it would do mischief, and settles on the bottom, where it is comparatively harmless.

These tubular boilers are however subject to disadvantages peculiarly their own. It is not so easy to move about within them for cleaning and examination as in the plain cylindrical boiler, as the tubes fill up the space so much. The difference of expansion between the highly heated tube and the comparatively cool shell produces a strain, which causes the ends to bulge out; or if the ends are made rigid, the strain sets up a contortion in the tube, which causes furrowing of the plates by making the iron softer or more susceptible of corrosion in certain lines of strain. Notwithstanding these drawbacks however this form of boiler is an excellent one.

Many modifications in the forms of boilers have been made to enable the manufacturers to use the waste heat from various processes, especially from the making of iron. The plain cylindrical boiler has been used in this way, with sometimes as many as eight puddling furnaces made to work upon one boiler. One of the earliest special arrangements for this purpose was the Upright boiler with central tube, shown in [Fig. 43](#), which was originally made for two furnaces; and about 7 feet diameter and 16 feet high. The size has since been increased to 10 feet diameter and 28 feet high, as shown in [Fig. 44](#). These boilers are made for one, two, three, or four puddling furnaces; and consist of a cylinder with spherical ends, standing upright, with a central tube from the bottom to about half the height, into which the side tubes join. The heat from each furnace plays over a portion of the shell, and then passes through the side tubes and down the centre tube into the underground flue to the chimney.



Fig. 43.

These boilers have many good points: there is great heating surface; and the shell being heated all round does not strain the plates and seams by unequal expansion so much as in the horizontal plain cylindrical boiler heated only at the bottom; and as both ends are spherical there is no alteration of shape under internal pressure. Moreover in consequence of the upright position of the boiler a safe depth of water can easily be maintained, and yet the steam is taken off so high above its surface that there is little priming; and every part can most easily be cleaned and examined, as a man can stand upright both in the boiler and in the flues. But the great drawback to this class of boilers is that they must stand in the midst of the workmen; so that, although they are not more liable to explode than any other form of boiler, yet when they do burst they necessarily endanger more lives than is usually the case with other boilers that can be placed more away from the men employed at the works. Should anything arise with the boiler to make it desirable to withdraw the fire, this cannot be done without much delay, as the furnaces have to be stopped and the iron run out. Also an explosion can hardly happen without some of the melted iron being scattered among the men at work.

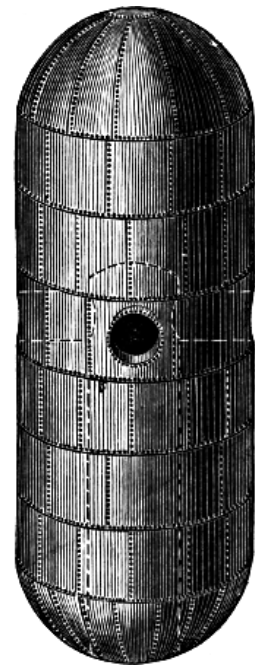

Fig. 44.

Some of the most fatal explosions of these boilers have arisen from careless construction. Such was the case in an explosion at Dudley in 1862, shown in [Fig. 45](#), where the crown plate forming the top of the centre tube was attached to the sides of the tube by so slight an angle iron, as shown enlarged in [Fig. 46](#), that the pressure of steam on the flat crown plate fairly sheared the angle iron through, and allowed the plate to be blown down the centre tube into the chimney flue, whereupon the boiler was violently thrown off its seating by the reaction of the issuing steam and water thus liberated.

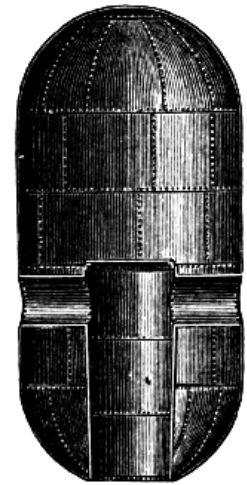

Fig. 45.

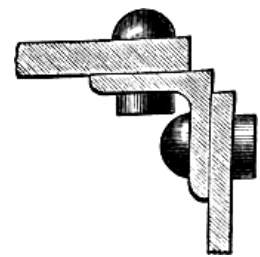

Fig. 46.

The double-tube horizontal boiler is also used in connection with iron-making furnaces in many places, one furnace working into each tube. Although by this arrangement the boiler can be placed a little further from the workmen, some very fatal explosions have happened to such boilers, as at Masborough in 1862.

Single-furnace boilers have been much used in the form of a single-tube boiler standing on end, as shown in [Fig. 47](#), with the flame passing up the tube, which is continued in the form of a chimney on the top of the boiler. The tube passes through the steam at the top, so that the plate is not protected from overheating by contact with water; and this has caused explosion in some instances, although the tube has been lined on the inside with firebrick to shield the plate from the flame. Another great disadvantage of this Chimney boiler is that the space between the tube and the shell is so narrow that it is almost impossible to examine or clean it internally.

A further arrangement for a single-furnace boiler is the Elbow boiler, shown in [Fig. 48](#), where the two difficulties mentioned in the previous boiler are avoided.

Many internally fired upright boilers of various shapes have been constructed to suit various purposes. One of a large size that has been at work many years is shown in [Fig. 49](#), with an internal fireplace and a suspended cone and cross tube for increasing the heating surface. This boiler is set in brickwork in such a way that the heat passes through the side tubes and round the exterior shell before going off to the chimney.

A very fatal explosion at Stoke-upon-Trent, in 1863, resulted from an attempt to work a boiler of somewhat the same general form, but without the same careful attention to the details of construction. This boiler is shown in [Fig. 50](#); the internal fireplace is of conical shape, 4 ft. 6 ins. diameter on the top and 6 ft. 10 ins. at bottom, and was joined to the external shell by a flat annular bottom. Almost the first time it was worked at high pressure the conical fireplace collapsed, breaking off at the seam at the top

of the cone, and blowing down upon the grate, as shown in [Fig. 51](#). The flat bottom was then left without the support of the cone and side tubes, and gave way all round the outside angle iron; and the top flew up a great height into the air, and fell a crumpled heap, as shown in the sketch. In this case the only wonder is that a boiler of such weak construction worked at all without explosion.



Fig. 47.

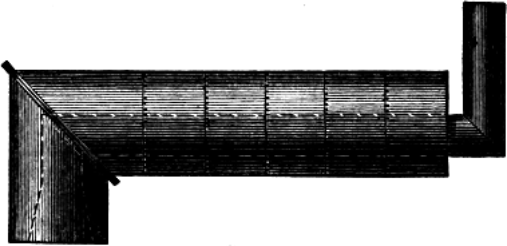

Fig. 48.

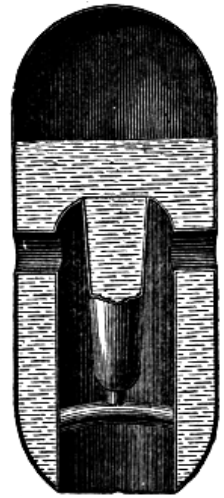

Fig. 49.

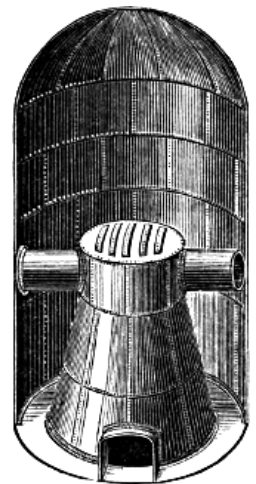

Fig. 50.



Fig. 51.

There yet remains to be noticed a very large and varied class of boilers that have been designed with the express object of avoiding explosion. Some of these, made of cast-iron pipes of small diameter, have already been referred to. When steam carriages were first constructed, boilers were tried made of a cluster of small pipes, set both upright and horizontally, connected with a general receiver and with each other by still smaller pipes. These were found to have such small circulation of water that they

very soon burnt out, and also led to much priming. Afterwards, narrow chambers made of corrugated plates set like the cells of a battery were tried, but without much success. The multitubular boilers of the locomotive type soon superseded all others as quick steam generators, and until lately they have been considered as almost absolutely safe from explosion. It is found however that the barrel of these boilers is peculiarly liable to furrowing, owing to the strain weakening the iron in certain lines. Perhaps no boiler shows more clearly than the locomotive how necessary it is that every part should be open to examination; and also how unwise it would be to use for stationary purposes small cramped up boilers, only intended to meet the necessities of locomotion. Many explosions of locomotive boilers have taken place; but it is not necessary to give details in this paper, as they are fully given in the published official reports of the government inspectors.

Among the form of boilers designed to obtain very rapid generation of steam, combined with increased safety from explosion, may be specially named that consisting of a system of small pipes within a shell with an artificial circulation of water, and also the boiler consisting of a cluster of cast-iron spheres, both of which have been described at previous meetings of the Institution (see Proceedings Inst. M. E. 1861 page 30, and 1864 page 61); but neither has been much used in this country at present. The boilers also which consist chiefly of small tubes hanging down into the fire, with smaller tubes or other arrangements within them for securing a natural circulation, deserve mention, as they appear successfully to accomplish that end.

The principle of all these small boilers appears to be that only a small quantity of water should be contained in them, so that there should not be a reservoir of danger in the shape of a mass of highly heated water ready to be converted into steam if a rupture takes place: and it cannot be denied that this is an advantage. But on the other hand these boilers of small capacity, which evaporate their whole contents in a few minutes, are subject to new dangers from that very cause; and although admirably adapted for purposes where steam is wanted quickly on a sudden emergency, as in the case of fire engines, or where the generating power required varies each moment, as in the locomotive, they are for the most part ill adapted for ordinary stationary purposes, such as the mill or the colliery. They require constant firing and vigilant attention to the feed, and cannot be left for a time with safety like the ordinary stationary boilers. It has to be borne in mind also that the very reservoir of danger so much dreaded is also a reservoir of power, which assists in the steady maintenance of the machinery in motion. The large mass of water heated to the evaporating point, the heated brickwork of the flues, and the large fireplace, are so many assistances to regularity, and enable the man in charge to attend to his other duties without the risk of spoiling the boiler or letting down the steam by a few minutes' absence from the stoke hole. Steam employers are found at present to prefer the known dangers of the large boilers to the supposed safety of small boilers, which they fear are troublesome in practice.

Many of the early boilers were rendered weak by the injudicious manner of arranging the seams. The longitudinal seams were made in a continuous line from end to end, as shown in [Fig. 24](#), page 20, with the transverse seams also continued completely round the boiler, so that at the corner of each plate there were four thicknesses of iron. The crossing of the seams, as in [Fig. 25](#), page 21, adds much to the strength, and also often prevents a rent from continuing forward to a dangerous extent.

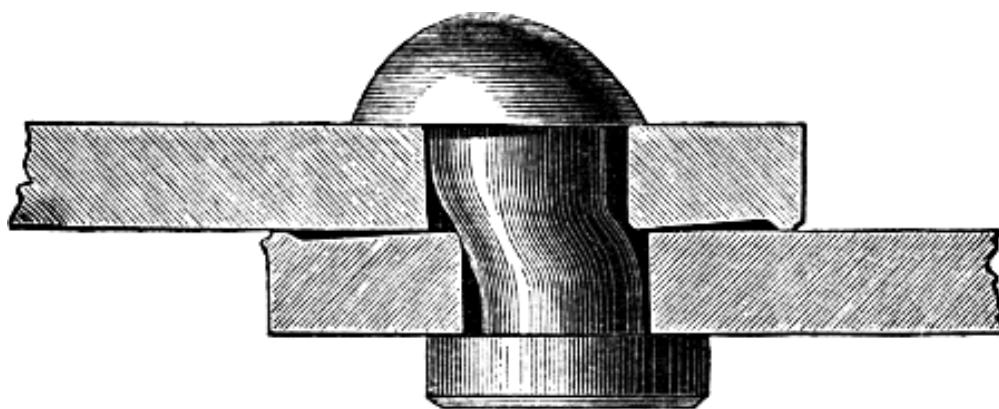

Fig. 52.

It is scarcely requisite to mention the necessity of good material and workmanship to secure strength in a boiler, however perfect the design. If the plates are of weak and brittle iron, or imperfectly manufactured, they will never make a good boiler. Apart from the strain upon the boiler when at work, the iron has to undergo the strain of the necessary manipulation, shaping, and punching, during the construction of the boiler. If the plates forming the boiler are not well fitted to their places before the rivet holes are made, the errors have to be partially rectified by using the drift in the holes to an

unwarrantable extent, and then using imperfect rivets to fill up the holes that do not correspond with each other; and the mischief is too frequently increased afterwards by excessive caulking, in the endeavour to stop the leaking which is sure to show itself. In this way a boiler is often exposed to most unequal internal strain between its several parts before it is set to work at all; and when the heat is applied to it, the mere expansion causes undue contortion, and leads to seam rips, and ultimately to disaster. Several specimens of faulty rivetting and caulking were exhibited to the meeting, and a sketch of one of them is shown in [Fig. 52](#).

The strength of a boiler is often very much lessened by the injudicious manner in which the mountings are fixed upon the boiler, and many explosions are the consequence of this defect. Not only are a great many holes for fittings cut out of the boiler in one line, but these holes are made needlessly large. Steam domes are often so placed as greatly to weaken the shell of the boiler, the hole cut out of the plate being made the full diameter of the dome; and in some cases the domes or steam chests have been made square or rectangular, so as to weaken the shell still more, as shown in [Fig. 53](#).

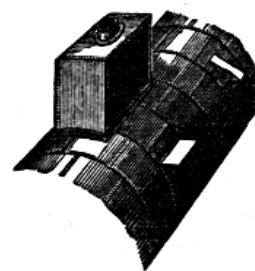

Fig. 53.

Manholes are often a source of danger, if not properly arranged and duly strengthened. Even in very small boilers they are often placed with the longest diameter in the longitudinal direction of the boiler, so that the shell is greatly weakened, as in the sketch, [Fig. 54](#), of an exploded boiler at Walsall in 1865. This boiler was 5 ft. 3 ins. long and 2 ft. 6 ins. diameter, and yet the manhole was 18 inches by 13 inches, and placed within a few inches of one end. The end was fastened in by angle iron, which was not welded, and consequently there was so little strength at the small portion of the shell between the end and the manhole that it gave way and liberated the end and the manhole lid, after which the main body of the boiler was thrown by the reaction across several streets to a great distance.



Fig. 54.

A somewhat similar injudicious arrangement of the manhole is shown in [Fig. 55](#), where a manhole 17 inches by 14 inches was cut out of the flat top of a steam dome only 2 ft. 6 ins. diameter, without any strengthening ring to compensate for it. The repeated strain of screwing up the manhole lid, combined with the pressure of the steam, caused the lid to force its way out through the plate and blow away. This explosion occurred at Birmingham in 1865.

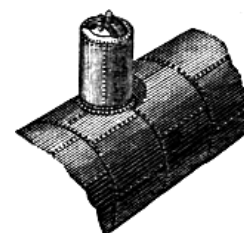

Fig. 55.

The preceding examples have shown how explosions often result from faults in the construction of boilers; and the following instances illustrate the explosions caused by mischief arising during working. A boiler perhaps more than any other structure is subject to wear and tear; and let it be worked ever so carefully, it will seriously deteriorate. The wonder is, considering the work they have to perform, that so many boilers are found which have worked twenty, thirty, or even fifty years without explosion. The terms wear and tear however are too vague for this subject, and the mischief met with must be considered under distinct heads.

There is no doubt that the thing most to be dreaded for boilers is corrosion; because when the plate is once thinned, it cannot be strengthened again, but must remain permanently weakened. Corrosion the more deserves attention because it is easily detected by moderate vigilance, and can generally be prevented by moderate care, or by the boilers being so arranged that they can be readily examined in every part. Corrosion has been the direct and unmistakable cause of a very large proportion of the explosions that have happened: it occurs both inside and outside the boiler, according to circumstances, and attacks the iron in various ways and in different places.

Internal corrosion sometimes takes place from bad feed water, and its effects are different in extent in the different parts of the same boiler. It very seldom thins the plate over a large surface regularly, but attacks the iron in spots, pitting it in a number of holes. These are sometimes large, as if gradually increasing from a centre of action; and sometimes small, but so close together as to leave very little more space whole than that which is attacked. A very curious example of the latter was exhibited to the meeting, and shown in [Fig. 56](#) and [Fig. 57](#), cut from the lower part of the shell of a large tubular boiler externally fired. The corrosion was greatest along that part of the shell most exposed to heat, and was so extensive that two boilers exploded simultaneously. The boilers had been at work sixteen years, but the corrosion commenced about eight years before the explosion, when the feed water was rendered corrosive by being obtained from some iron mines. This explosion occurred at Aberaman in 1864. The corrosion had been seen going on for years, and was not considered sufficient to cause danger; but the depth to which it extended through the thickness of the metal is seen in the half size section, [Fig. 57](#).

Another sample equally curious was exhibited to the meeting, and shown in [Fig. 58](#) and [Fig. 59](#), taken from the sweep plate over the fire in a plain cylindrical boiler which had worked about ten years. The feed water was occasionally bad, and attacked the iron over the area **DDD**, where unprotected by scale. The protection afforded by scale against occasional corrosive feed water is worthy of notice. In the two specimens exhibited it is seen that the protection has been perfect where the scale has not been chipped off; and the edge of the sound part projects over the hollow, as seen in the half size sections, [Fig. 57](#) and [Fig. 59](#), the corrosive water having eaten away a larger area beneath than that through which it first entered the surface of the iron.

Internal corrosion is frequently observed where boilers are fed from canals or streams in the neighbourhood of chemical works from which corrosive matter is discharged at intervals into the water. The corrosion takes place in isolated spots, but causes deep holes; which seems to be accounted for on the supposition that the scale previously upon the plate cracks during the cooling of the boiler for cleaning, and forms a blister, so that a piece of about 2 inches area is raised slightly from the iron. When the boiler is again put to work, this blister becomes filled with the corrosive water, which is held there without circulation and causes corrosion. When the boiler is again emptied these blisters may be seen, and if broken show the blackened water and the injured surface. In future working each of these blisters forms a constant unprotected point for attack. It is frequently seen further that such corrosion is arrested if water be used which deposits scurf; but fresh blisters and renewed corrosion will result from a return to the use of the bad water.

The internal corrosion called furrowing has proved a frequent cause of explosion, especially in locomotive boilers. It differs from other corrosion by being in deep narrow continuous lines with abrupt edges. It will sometimes go completely through a plate; and is found where a sudden change of thickness occurs, either along the lines of the seams, or opposite the edge of angle-iron attachments. This effect is supposed to be due to the alternate springing of the plates under each variation of the pressure or temperature, causing the line of least resistance to receive a strain somewhat similar to that produced by bending a piece of iron backwards and forwards for the purpose of breaking it. This line of injury is exposed to constant attack from corrosion, because the scurf is always thrown off from it.

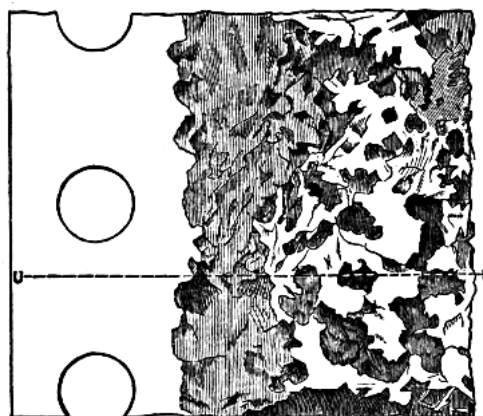

Fig. 56.

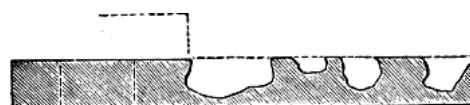

Fig. 57.

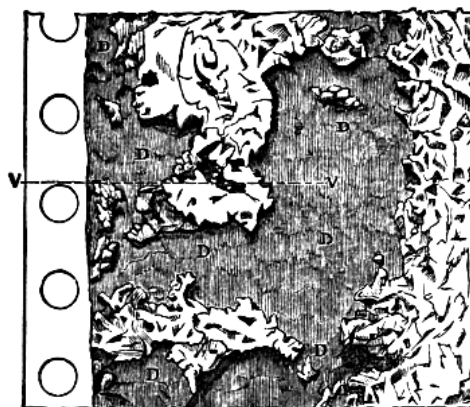

Fig. 58.



Fig. 59.

External corrosion is a far more frequent cause of explosion in stationary boilers; and it arises from many causes. The most frequent cause, although the most easily detected, is leakage from the joints of the fittings on the top of the boiler, which are too frequently attached by bolts instead of rivets. This

evil is much increased when the boilers are covered with brickwork, which holds the water against the plates, and hides the mischief from observation. It is astonishing to find how much damage is allowed in this way to go on without attention, until the tops of boilers are corroded so thin that little holes burst through. These are sometimes found stopped with wooden pegs or covered by screwed patches of plate, either of which cause leakage that hastens the mischief, as shown by the sample exhibited. Boilers exposed to the weather will of course become corroded like anything else made of iron and not painted; and yet so much mischief is sometimes caused by leakage beneath improper covering that exposure may almost be said to be the smaller evil of the two, as it is better to see what is going on than to rest in false security. No covering will be found cheaper, or better, in the long run, than a roof, which prevents the loss of heat by exposure, and yet allows free access to all the fittings and joints on the top of the boiler.

Some examples of the evils of covering can be given that have come under the writer's observation. A set of boilers had been well covered by arches of brickwork, so built as to keep out all water, and also set so as to touch the boilers only at intervals, leaving a space generally of a few inches. After about seven years' working, the whole of the tops of the boilers were discovered to be dangerously thin, and had to be renewed. The cause was leakage from the joints of fittings and seams of the boilers, and the issuing steam had been drawn along the space between the boilers and the arches, and had escaped at a place where it had not attracted notice. In another case, a somewhat similar set of boilers were covered with ashes, to prevent the loss of heat by radiation; and the rain and the leakage beneath the ashes, in conjunction with the corrosive matter from the ashes themselves, thinned the tops of the boilers to a dangerous extent in less than two years. A sketch of the corrosion caused in this instance by covering with ashes is shown in [Fig. 60](#) and [Fig. 61](#).

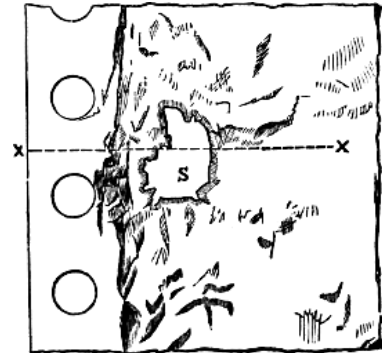

Fig. 60.

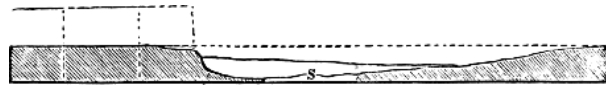

Fig. 61.

Similar mischief has been noticed in boilers covered with sand, as shown in the sketches [Fig. 62](#) and [Fig. 63](#), which represent an instance of corrosion after eight years' working; although nothing forms a better covering than sand for preventing loss of heat by radiation. In both these examples it will be seen that the corrosion has continued until the thickness of the plate has been so eaten away that a hole has been burst out at **SS**. A very good covering is formed by brickwork in cement; or various cements made for the purpose, which adhere to the surface of the plate and yet show leakage; or such materials as sacking or felt; or sheet-iron casing, leaving about 6 inches of air space all round the boiler. But all these have the great objection that they hide the boiler from inspection, except by the expensive process of removing the covering; and in this way dangers that have caused explosion have remained hidden from observation.

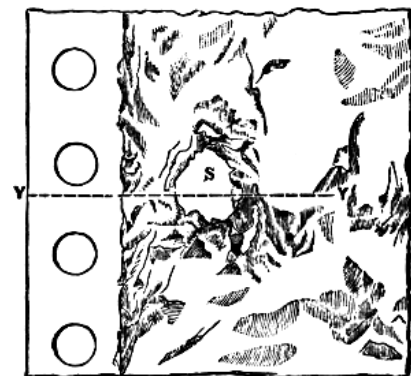

Fig. 62.

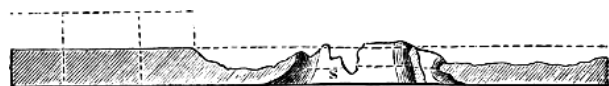

Fig. 63.

Explosions have also taken place from general corrosion of the surface of the boilers in the flues. A new boiler which was set on sidewalls built upon a foundation of porous rock was found to have become corroded all along the bottom in less than two years, owing to the dampness which rose from the foundations causing a constant presence of vapour. The corrosion was peculiar, and more like that found on old iron left for a long time in a damp place; for the iron plate fell to pieces when touched, and large flakes could be raised from the surface, and the greater part of the thickness of the plate could be removed with the fingers. Somewhat similar corrosion had taken place in a boiler which exploded at Loughborough in 1863; the bottom of the shell became rent at the corroded part, and as the fracture continued spirally round the boiler several times, nearly all the shell was peeled off in the curious manner shown in [Fig. 64](#). The explosion shown in [Fig. 65](#), which occurred at Leeds in 1866, also arose from corrosion of the bottom of the boiler.

The greater part of the corrosion found in the side flues of boilers is caused by the leakage of seams. Many boilers are emptied for cleaning as soon as work is over on Saturday night, and long before the brickwork of the fireplaces and flues has cooled; and consequently, the boiler, having no water in it, is made much hotter than it ever is in working, and the seams are injured and sprung and the rivets loosened by the extra expansion so caused. This is sometimes done intentionally, in order to loosen the scale by the greater expansion of the iron than of the scurf. When the boiler is again set to work, the seams and rivets leak and cause that corrosion which is called channelling. This has been observed to occur to such an extent that all the seams in a boiler have been seen thus corroded; and the same has sometimes been found in all the boilers in a large manufactory. Specimens of this channelling were exhibited to the meeting. One in particular, shown in [Fig. 66](#) and [Fig. 67](#), deserves attention, as it shows the effect of a jet of steam and water from the leaking rivet **R**, in cutting a series of channels into the plate along the course of the dotted lines **EEE**, and producing a hole in the plate at **S**. This corrosion had been going on for about four years, but was in a part of the boiler seldom seen in ordinary examination. Many explosions have resulted from this form of corrosion; for when a rent is once made, the fracture continues along the thinned channel of the plate.

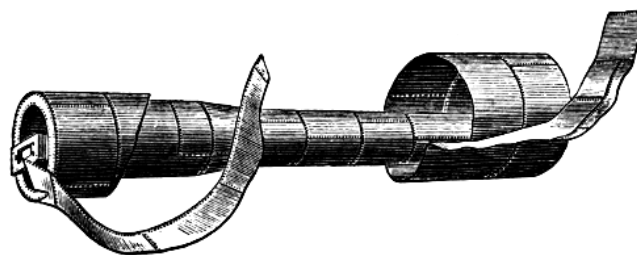

Fig. 64.

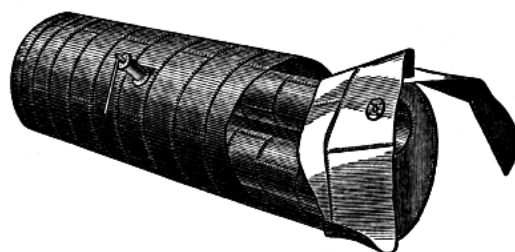

Fig. 65.

The corrosion most to be dreaded, because most difficult to detect, is that which takes place where the boiler is in contact with brickwork; and it is found alike in all forms of boilers set in brickwork. When found at the part where the side flues are gathered in at the top against the boiler, it is usually occasioned by the leaking of fittings or feed pipes, or by rain being allowed to run between the boiler and the brickwork. More than one explosion has been caused by the droppings from a roof being allowed to fall upon the tops of the flues. When the corrosion is found at the point where the bottom flue walls touch the boiler, it is frequently caused by the leaking of seams that have been strained by the weight of the boiler; and this often arises from want of care to replace the brickwork, after repair of the boiler or flues, in such a position as to take again its proper proportion of the weight of the boiler. Cases have been met with where the shape of the bottom of large boilers has been quite altered by such means. The brackets on the sides of heavy boilers have not only been strained so that the rivets or bolts have leaked and caused corrosion, but they have also bent or cracked the side plates of the boiler. The bracket shown at **B** in [Fig. 53](#), page 40, made of only an angle iron with a piece of plate attached, is especially liable to cause injury if the brickwork is not rebuilt close up to the angle iron, as the leverage is so great. This is avoided by the better form of bracket shown at **C**, consisting of an elbow of flat bar-iron rivetted at top and bottom to the boiler.

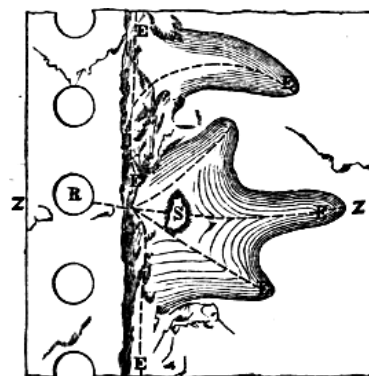

Fig. 66.

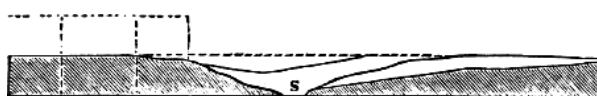

Fig. 67.

In the old balloon and wagon boilers, the angle where the bottom joined the sides scarcely ever remained sound for long when in contact with the brickwork, and many of those that exploded have been found almost corroded through where they stood upon the brickwork. The explosion before alluded to and shown in [Fig. 7](#), was caused by corrosion of the bottom of the boiler where it was set on the brickwork. Many boilers are so set that the brickwork of the flues is made to follow the shape of the boiler, with as little space between as possible; but the slight advantage gained in increased heating effect is far outweighed by the impossibility of getting into the flues for examination. It is only by

having the flues sufficiently roomy that proper examination can be made, and that the indications on the brickwork of leaking can be seen and remedied, and corrosion arrested. A remarkable case of corrosion occurred in a boiler with an oval shell, set upon a middle wall. The flues were too narrow for a man to enter, and a leak in the bottom was only discovered by the boiler nearly running empty while the engine pumps were standing for a short time. It was subsequently found that the whole bottom where it rested on the wall was extensively corroded in a continuous line, and that explosion was only prevented by the numerous stays across the bottom to compensate for the oval shape. [Fig. 68](#), shows the position and extent of the corrosion, and the plate was completely in holes at the parts indicated by the black marks. This corrosion was supposed to have been going on for about three years.

It is sometimes asserted that corrosion cannot be the cause of an explosion, because the corroded place would simply give way and let off the steam harmlessly, or at least the boiler would not be displaced from its seating. When the corrosion is only local, and surrounded by sound plates of sufficient strength to arrest the extension of the fracture, this may be the case, as in an explosion at Sheffield in 1865, shown in [Fig. 69](#), where a piece of plate was blown out on one side of the boiler, allowing the steam and water to escape without displacing the boiler; the thickness of the plate at that part had been reduced to 1/8th inch by corrosion in about 1½ years, which had been caused by leakage at the seams from inefficient repair with bolts instead of rivets, and also from the moisture having been allowed to be kept against the plate by the brickwork. But even under such circumstances, if the piece blown out should be from the bottom, the whole boiler may be thrown a great distance by the reaction of the issuing steam, as in an explosion at Leeds in 1865, shown in [Fig. 70](#). If the corrosion extends for any length, the first rent is almost sure to continue until a complete explosion is the result. Several of the small models exhibited to the meeting showed the line of fracture in various cases of explosion. One showed the appearance of a plain cylindrical boiler after explosion caused by corrosion along the whole length where it rested on brickwork; this explosion occurred at Wigan in 1865, and a sketch of it is given in [Fig. 71](#).

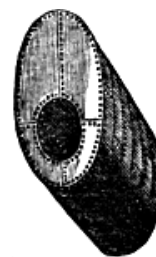

Fig. 68.



Fig. 69.

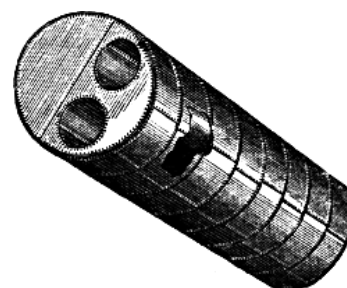

Fig. 70.

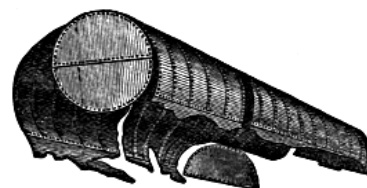

Fig. 71.

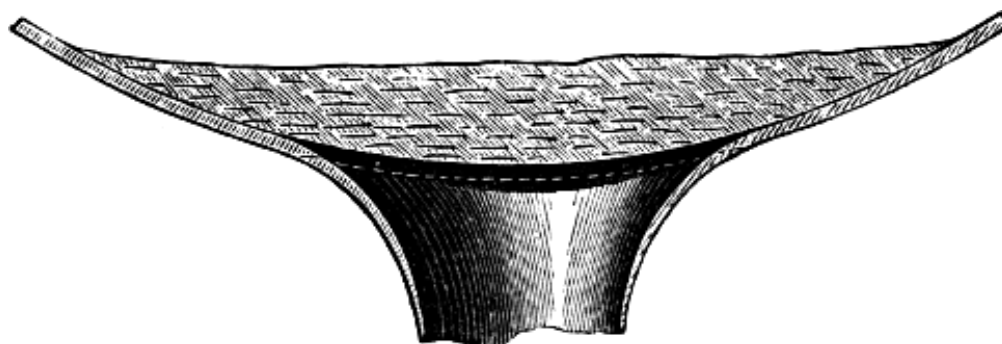

Fig. 72.

Many explosions of boilers have been caused by accumulation of scurf. The mischief is not so much from scurf being gradually deposited all over the interior of the boiler to a dangerous thickness as from the chips off the sides falling in heaps on the bottom. The plate beneath this accumulation becomes overheated, because not in contact with the water, and softens and sinks down into a "pocket," which if unnoticed will soon burn quite through. If the scurf that has caused the mischief is thick and hard enough to resist the pressure for a little time, the hole enlarges, until the scurf suddenly gives way and allows the contents to issue so violently as to disturb the boiler, or at least to blow the fire out of the grate. Such was an explosion at Bilston in 1863, where a large plain cylindrical boiler, 9 ft. diameter, was heated by three large fires placed side by side along the bottom; and a large "pocket" burst out over the third grate, and scalded the attendant to death. A similar pocket in a boiler, 4ft. 6 ins. diameter, which exploded at Dudley in 1864, after having been at work six weeks without cleaning, is shown in the transverse section, [Fig. 72](#). In this case the scurf had filled up the circle of the boiler to a depth of 3 inches at the bottom, as shown in the drawing, and was of a very hard description; and the boiler plate was bent out in a gradual curve, and thinned to about 1/16 inch, the original thickness being 1/2 inch.



Fig. 73.

The whole bottom of a boiler is sometimes injured, and the plates buckled and the seams sprung, from the accumulation of mud. One case may be mentioned where the water was very full of mud, and the boilers were worked day and night during the week but stopped for several hours on Sunday, during which time the deposit of mud was so thick that it did not get thoroughly disengaged again from the bottom when the boiler was set to work, but hardened into a mass. Although many of these pockets and injuries to the plates may occur without serious damage, they sometimes cause that first rent which destroys the equilibrium of the structure and leads to explosion. Some of the specimens of scurf exhibited to the Meeting show that their thickness is made up of small chips, carelessly left after cleaning or fallen from the sides of the boiler, as seen in [Fig. 73](#), or from cotton waste or other matter left in the boiler and forming a nucleus for the scurf to accumulate upon. Other specimens show that foreign matter must have been put into the boiler to stop leaking.

Accumulations of scurf in the feed pipes at the point of entrance into the boiler have also caused explosion by stopping the supply of water. The same result is caused by the freezing of the water in the pipes which are exposed, and each winter one or two boilers are injured or exploded from this cause, especially small household boilers placed behind kitchen grates. Scurf cannot be considered so great an evil as corrosion, since it can be removed, and if this is done in time, the boiler is restored to its original condition.

The advantage of a pure water, which does not deposit scurf, is so great for the supply of boilers that it is always worth while to go to considerable expense for obtaining it; or to take some steps for purifying the feed water as much as possible. If it is only mud mechanically suspended, which would deposit by gravity on the bottom of the boiler, frequent use should be made of the blow-off apparatus. If the impurity is light enough to be carried to the surface in the form of scum, the blow-off apparatus should discharge from the surface of the water as well as from the bottom. If the impurity is chemically suspended in the water, some one of the many substances which form the refuse from various manufactures, and which may contain suitable ingredients, should be used to counteract the effect of the impurity. Common soda will answer the purpose perhaps better than anything else. It must not be forgotten however that the blow-off apparatus must afterwards be used more frequently, to rid the boiler of the foreign matter, or the mischief will be increased. In marine boilers, constant attention is necessary to get rid of the saline deposit; and in stationary boilers using impure water an equally systematic attention is needed to get rid of the earthy deposit.

Perhaps no cause of explosion is oftener mentioned than shortness of water, and this is not

unfrequently coupled with turning on the feed suddenly into an overheated boiler. Many explosions have been attributed to this cause, when closer investigation would have revealed some far more probable reason. For instance, shortness of water was stated as the cause of the explosion, at Abercarn in 1865, of a single-tube boiler with a very large flue tube, which collapsed upwards from the bottom. The top of the tube and the sides of the shell had not the slightest mark of overheating, although exposed to the flame of three furnaces, one of which worked through the tube, and the others on each side of the shell. In this case the cause of explosion was clearly the weakness of the tube, and not shortness of water. It is erroneous to suppose that if a boiler runs dry, or if the feed is turned into a red-hot boiler, there must necessarily be an explosion. If a boiler unconnected with any other runs rapidly empty, from the breaking of the blow-off pipe or any such cause, it will simply get red-hot and sink out of shape upon the fire, as may often be seen, but no explosion would happen. If the water only falls gradually, as it would if the feed were turned off and evaporation continued, the parts exposed to the fire would get overheated as the water left them. If the subsidence of the water were very slow, those parts might get red-hot, and so much softened and weakened as to be incapable of bearing the pressure, when an explosion would take place, as at Smethwick, in the present year, where the flues were set above the water line, as shown in [Fig. 74](#).

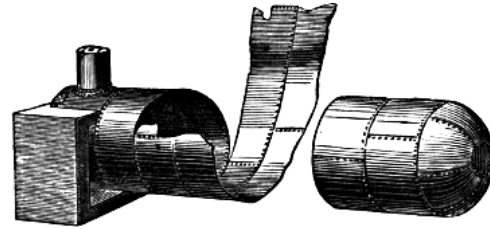

Fig. 74.

If however the water were turned on again before the overheating had gone so far, and the feed pipe were, as usual, carried down to nearly the bottom of the boiler, the water would gradually creep up the heated sides and cool the plates, the heat of which would not be sufficient to cause greater evaporation than the ordinary safety valves would carry off. The danger would not arise so much from the excess of steam generated by the heat accumulated in the heated plates of the boiler, as from the injury and strain that would be caused to the plates by the undue expansion and sudden contraction, especially as this action would take place on only a portion of the boiler. A singular case, bearing on this point, may be mentioned. A four-furnace upright boiler, like that shown in [Fig. 44](#), happened to run so nearly empty, through the accidental sticking of the self-acting feed apparatus, that the level of the water sank to the top of the hemispherical end forming the bottom of the boiler. The feed apparatus then became released of itself, and, the feed being turned full on, the water gradually rose until the whole occurrence was only discovered by the leaking at the seams that had been sprung, which caused so much steam in the flues as to stop the working of the furnaces. The overheating had been sufficient to buckle the plates, and in one place a rupture had almost commenced; but there was no explosion. By way of direct experiment upon this point, boilers have been purposely made red-hot and then filled with cold water, without causing explosion.

It has been supposed that boilers sometimes explode from overheating without the water level being below the usual point, or without the accumulation of scurf previously alluded to, but simply by the rapidity of the evaporation from an intensely heated surface causing such a continuous current of steam as to prevent the proper contact of the water with the heated plate. Such has been the cause assigned for the explosion of a three-furnace upright boiler at Birmingham in 1865, shown in [Fig. 75](#). A piece of plate about 3 ft. by 1½ ft. was blown out of the side, at a place where an enormous flame impinged continually. The plates had first bulged out, and then given way in the centre of the bulge, each edge being doubled back and broken off. There was no positive evidence as to the water supply; but the crown of the centre tube, which was much above the bottom of the part blown out, remained uninjured.

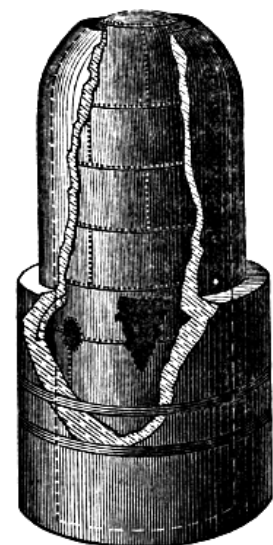

Fig. 75.

A somewhat similar case was that of a large horizontal boiler at Kidderminster, the tube of which collapsed in 1865, as shown in [Fig. 76](#). It was heated by four furnaces, one of which worked into the tube, one under the bottom, and one on each side; and all the furnaces worked into the same end of the boiler. The tube was found to have partially collapsed at that end, and the top had dropped 11 inches. This was repaired in the first instance, but was afterwards again found injured by overheating, although not so seriously. It is very probable that the extremely rapid ebullition from the sides and bottom, from which the steam had to pass up the narrow space between the tube and the shell, produced such a foaming that very little solid water could reach the top of the tube where it was exposed to extreme heat.

Many explosions have been attributed to deterioration of the iron through long use, as in an explosion at Durham in 1864, and another at Haswell, near Sunderland, 1865, where the boilers had worked constantly for 25 and 30 years respectively. When an explosion arises from the failure of a plate which has not been properly welded in rolling, there is no question that it was unsound when put in, and escaped notice; but when the plate that fails is found to be brittle and of bad iron, the fault is rather attributed to the effect of working than to original bad quality. Of course this is not always the case, as the injury done to plates by overheating has been already explained. Pieces of plate have in some cases been erroneously pronounced to be deteriorated by work, which have been taken from situations in the boilers where they were not exposed to any action of fire that could cause overheating; and therefore in reality the injury could only have taken place when the boiler was being made, by burning the iron in bending it to the required shape. A frequent cause of fatal injury to boilers is injudicious repair, whereby the crossing of the seams is destroyed, as in the explosion at Wolverhampton in 1865, previously referred to and shown in [Fig. 36](#). Moreover the edges of the old plates, already tried by the first rivetting and the subsequent cutting out of the rivets, are frequently strained again by the use of the drift to draw them up to the strong new plates; and many a seam rip is thus started which ultimately causes explosion.

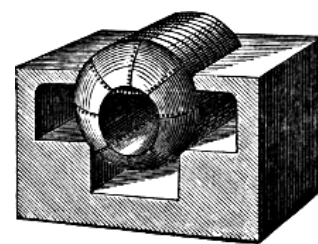

Fig. 76.

Many explosions have been caused by the want of proper apparatus for enabling the attendant to tell the height of the water and the pressure of the steam, and also by the want of sufficient apparatus for supply of feed water and escape of steam, or by the failure of one or other of these; but such explosions can only be referred to generally in the present paper. The mountings on a boiler are usually so open to observation, and the importance of having them good and efficient is so universally acknowledged, that much remark is not needed. Mention has already been made of the sticking of self-acting feed apparatus as a cause of mischief, and similar failures of floats and gauges have constantly happened; but this should by no means be considered to condemn self-acting apparatus, either for assisting in the steadiness of working, or for giving warning of danger. The apparatus however should be relied on for assistance only; and an attendant cannot be called careful who leaves a boiler dependent on such apparatus without watching. The self-acting principle has been seen by the writer applied in a novel and useful way in a recording pressure gauge, which proved the more interesting as it had shown the actual pressure of steam at the time of the explosion of one of the boilers with which it was connected.

Among the numerous boiler explosions that have been attributed to over-pressure through deficient arrangements for escape of steam, in many cases the safety valves have been placed on the steam pipes in such a manner that the communication with them was cut off whenever the steam stop-valve was shut, which is just the time when the safety valves are most wanted. Safety valves are too often found needlessly overweighted; and it is believed that many boilers are constantly worked with safety valves so imprudently arranged and weighted, that they could not carry off all the steam the boilers would generate without a very great increase of pressure.

It is concluded that enough has now been said to show that boiler explosions do not arise from mysterious causes, but generally from some defect which could have been remedied if it had been known to exist. It only remains therefore to consider what is the most ready and efficient way to discover the true condition of a boiler. It has been maintained that this end is best accomplished by what is called the hydraulic test, in which a pressure of water is maintained in the boiler for a given time at a certain excess above the working pressure. This test is undoubtedly useful so far as it goes, and is perhaps the only one that can be applied to boilers with small internal spaces, such as locomotive boilers, not admitting of personal inspection over the whole of the interior; and it is also admirable for testing the workmanship of a new boiler. But on the other hand the conditions of a boiler at work are so different from those which exist during the hydraulic test, that this alone cannot be depended on; for old boilers have been known to stand this test to double their working pressure without apparent injury, although known to be dangerously corroded. The difficulty also of seeing or measuring the effect of the hydraulic test upon large boilers set in elaborate brickwork is so great that little practical benefit has resulted in many cases.

It is believed by the writer that the surest way to ascertain the true condition of a boiler is to examine it at frequent intervals in every part, both inside and outside; and as this can only be done when both the boilers and the flues can be readily entered, it is specially important that facility for examination should be made a consideration in selecting a construction of boiler. Permanent safety should be considered as an element of economy, in addition to its still higher importance in reference to the preservation of life.

Conclusions

ON THE CONCLUSIONS DERIVED FROM THE EXPERIENCE OF RECENT STEAM BOILER EXPLOSIONS, BY EDWARD B. MARTEN, MEM. INST. M.E., EXCERPT MINUTES OF PROCEEDINGS OF THE MEETING OF THE INSTITUTION OF MECHANICAL ENGINEERS, AT NOTTINGHAM, 3RD AUGUST, 1870, THOMAS HAWKSLEY, ESQ., VICE-PRESIDENT, IN THE CHAIR. BY PERMISSION OF THE COUNCIL.

The records of Steam Boiler Explosions in recent years are very numerous, as the increased attention drawn to the subject in this and other countries has placed far more information at disposal; and the experience of the last four years, since a former paper was read by the writer on the subject of boiler explosions, has confirmed the opinion then expressed, that all boilers, however good in original construction, are liable in the course of time to get into bad order and explode. The particulars of the explosions during this period are given in the Tables appended to the present paper, which show the number of explosions due to each cause in each class of boiler, distinguishing those of the United Kingdom from those in foreign countries. An analysis is also given of the explosions in the last four years, showing the causes of explosion of each form of boiler; and also a summary of the causes of explosion under the three general heads—(1) faults in construction or repair: (2) faults in working which creep on insidiously and unnoticed: (3) faults which might be seen and guarded against by careful attendants. Nearly all of the faults in these three classes would have been detected by periodical examination.

In the case of Cornish, Lancashire, and other boilers with internal flues, the faults of construction which have caused explosions have been weakness in the tubes, combustion chambers, ends, domes, or manholes; and explosions in these, as in other classes of boilers, have also resulted from external or internal corrosion, shortness of water, undue pressure of steam, and scale or mud on the boiler plates.

In plain cylindrical boilers, and others without internal flues, explosions have resulted from the boiler ends being made flat, and also from frequent repairs producing seam rips, especially in boilers having the plates arranged lengthways instead of in rings.

In marine boilers, weak flues and weak ends have also led to explosion, in addition to the other causes mentioned above.

Locomotive boilers have in two cases exploded in consequence of the strains thrown upon them by their being used as a frame for the engine.

Other explosions have resulted from want of stays, and from too much heat impinging on some particular part; and in domestic boilers from freezing of pipes under pressure.

Altogether the total number of explosions in this country that have been recorded during the past four years has amounted to 219, which may be classed under the following heads:—

Faults of construction or repair	95
Faults to be detected only by periodical examination	62
Faults which should be prevented by careful attendants	54
Extraneous or uncertain causes	8
Total	<u>219</u>

By these 219 explosions 315 persons were killed and 450 injured.

The following are the particulars of the construction of the 219 exploded boilers:—

Cornish, Lancashire, or other boilers with internal flues	84
Plain Cylindrical boilers or others without internal flues	54
Marine boilers	12
Agricultural boilers	11
Locomotive boilers	10
Furnace-upright boilers	8
Crane boilers	6
Rag steamers, &c.	6
Balloon and Elephant boilers	5
Domestic boilers, &c.	16
Not sufficiently described	7
Total	<u>219</u>

The causes of these 219 explosions may also be classed as follows:—

Worn out, corroded, or burnt plates	89
Undue pressure, overloaded valves, intentional or from carelessness	25
Bad construction, defective fittings or stays, or want of repair	69
Shortness of water, formation of scale or mud, or external flues set too high	28
Extraneous or uncertain causes	8
Total	<u>219</u>

Sketches are given of the most instructive examples of boiler explosions during the last four years, which are sufficient to explain themselves, with a brief reference to their special features.

Although the importance of periodical examination as the best safeguard against explosion is generally admitted, a great number of those who make or use boilers have not at present sufficient belief in its importance to adopt this course. Boilers are still constructed or set in such a manner as to render examination next to impossible; and are continued to be worked without making it the duty of those who mind them, or of any one else, to examine every part at frequent intervals; and hence such explosions have occurred as shown in [Fig. 1, No. 12, 1870](#), in which the original position of the boiler before explosion is indicated by the dotted lines.

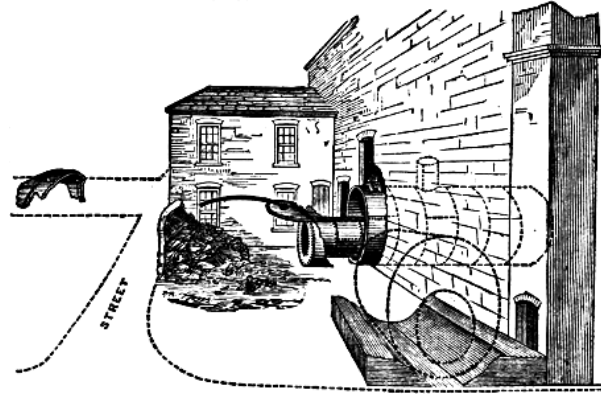

Fig. 1.

It is thought by many steam users that all has been done which is possible, if their boilers are the best that can be procured, and are set in the most approved way; and it is taken for granted that such boilers should last for many years, under the idea that a good boiler can never explode unless the feed is neglected. Similar boilers are often referred to as having worked safely for ten or twenty years, but it is forgotten that they may be exposed to the insidious action of furrowing on the inside or channelling on the outside, such as caused the explosions of the originally good boilers shown in [Fig. 2, Fig. 3, Fig. 4, and Fig. 5, No. 35, 1870; No. 50, 1866; No. 46, 1869; and No. 25, 1870.](#)

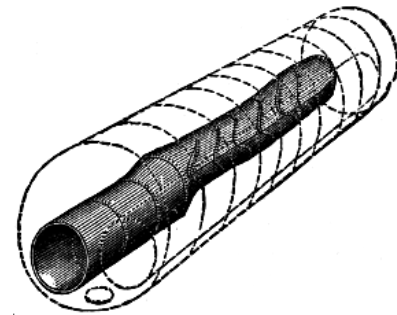

Fig. 2.

Much mischief arises from special classes of boilers, fittings, or apparatus, being looked upon as promising permanent safety from explosion; while the inevitable circumstance is overlooked that it is only so long as everything is maintained in good condition that safety is insured.

An apparatus, for instance, for preventing explosion from shortness of water or over-pressure, however perfect for any such object, would be quite inefficient as a safeguard against explosion from corrosion, furrowing, channelling, or weak construction. It is curious to note how often it is the case that every other part of an establishment is subject to severe and perpetual scrutiny, the engines especially being overhauled with the most scrupulous regularity; while the boilers, the very source of the power and the heart of the whole business, are left to themselves

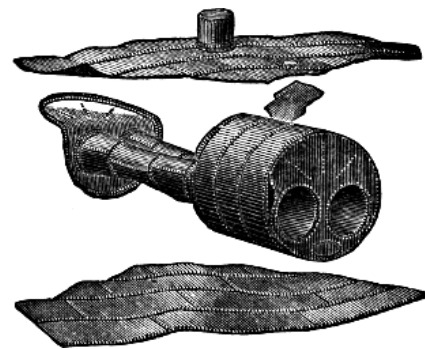

Fig. 3.

for long periods, even for years, without examination; and it is too often only after bitter experience that owners have understood the need of this examination. In this, as in many other matters, experience has shown that there is no royal road to safety, and that immunity is only secured by unremitting care and constant watchfulness. It should never be forgotten that even a good boiler can explode; for however good at the outset, sooner or later the time must eventually arrive, when such wear and tear will have taken place as will result in dangerous weakness, unless the boiler is carefully and systematically attended to. Although a boiler may even last safely for ten to thirty or more years if worked slowly and with care, no confidence can be placed in a boiler which has worked so long, unless it is examined in every part.

The opinion is more general than many are aware of, that explosions as a rule are caused by shortness of water and the sudden turning on of the feed water upon red-hot plates; and the appearances of injury in the plates from fire, arising in the ordinary course of working, have been frequently mistaken for signs of overheating from shortness of water at the time of explosion, as illustrated in [Fig. 6](#) and [Fig. 7](#), [No. 24, 1867](#), and [No. 59, 1866](#). Although boilers do explode from the softening of the plates by overheating in consequence of shortness of water, yet it is very doubtful whether the turning on of the cold water at such a time is ever the cause of explosion. The feed water being always introduced at the bottom of the boiler, as in [Fig. 8](#), [Fig. 9](#), and [Fig. 10](#), cannot be scattered suddenly near the overheated parts, but must rise gradually up the sides; and the boiler would have gone to pieces from the giving way of the softened parts long before the water reached them, as was the case in the explosions shown in [Fig. 11](#) and [Fig. 12](#), end of 1868. The experiment of injecting cold water into red-hot boilers has been carefully tried more than once, without producing any explosion.

Although it may be too much to suppose that boiler explosions will ever be entirely prevented, it is important that those who have the care of boilers should understand better what are the true causes of explosion, in order that they may know what to guard against in addition to shortness of water. This better understanding of the subject has been much retarded by the supposition that the causes of boiler explosions are beyond the comprehension of the boiler minders; and still more by the important differences of opinion among those under whom they work. Much evil has resulted from the promulgation of strongly expressed views, which have been founded upon facts but of too limited extent, and such as must become modified by consideration of the facts of a large number and variety of explosions. Mysterious theories to account for explosions have been resorted to only from want of clearer explanations.

Before considering in detail the causes of explosion, it is necessary to recall to mind that beyond question there is sufficient accumulated force in any working boiler to cause all the violent effects of an explosion, if this force be suddenly liberated. In [Fig. 13](#) and [Fig. 14](#), [No. 18, 1869](#), and [No. 63, 1866](#), are shown the violent effects of the rupture of vessels employed for steaming rags, which were filled with steam only. In ordinary boilers however there is present, besides the steam, a quantity of water heated much beyond the atmospheric boiling point; and when rupture takes place and the pressure is suddenly relieved, part of this water evaporates, and keeps up the supply of steam to continue the rupture and destruction. The explosion of a boiler differs from the discharge of electricity or lightning, which cleaves the air and instantly leaves a vacuum; it also differs from the discharge of detonating compounds which act suddenly and leave a vacuum; but it more nearly resembles the discharge of gunpowder, which burns sufficiently slowly to keep up a

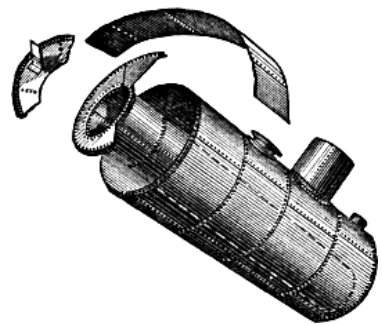

Fig. 4.

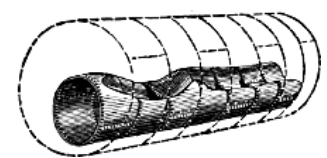

Fig. 5.

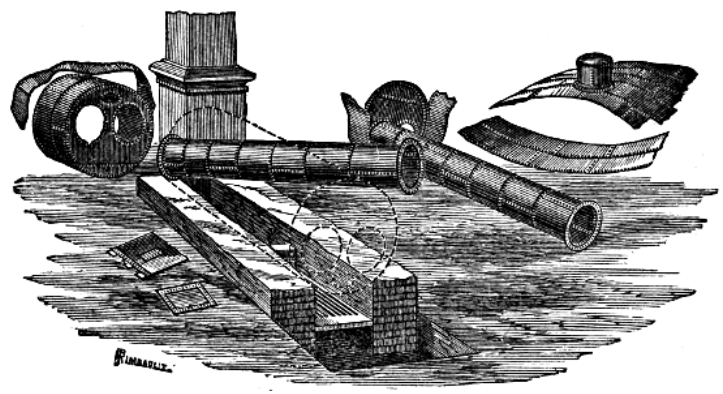

Fig. 6.

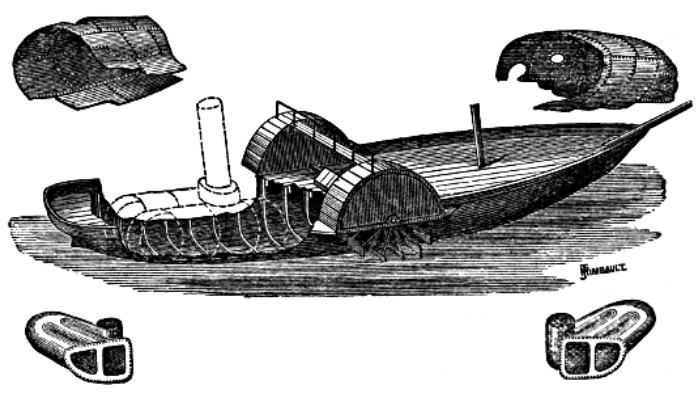

Fig. 7.

continuous pressure behind a projectile until it leaves a gun; and each cubic foot of water in a boiler working at 60 lbs. pressure has been shown to produce in steam an explosive effect equal to one pound of gunpowder. None of the elaborate but unlikely theories of decomposed steam, or of electric accumulations, suppose a force so fitted to cause destruction as that contained in the highly heated water existing in all working boilers.

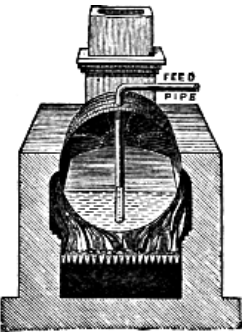

Fig. 8.

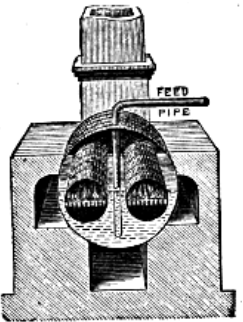

Fig. 9.

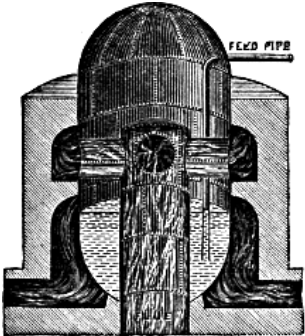

Fig. 10.

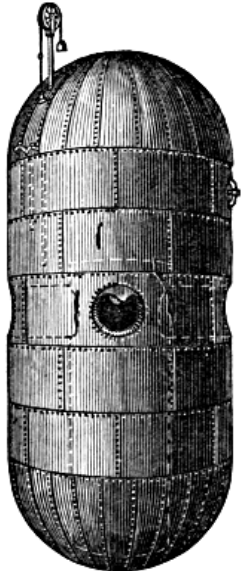

Fig. 11.

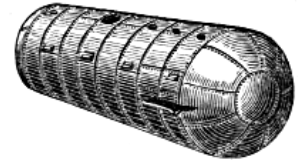

Fig. 12.

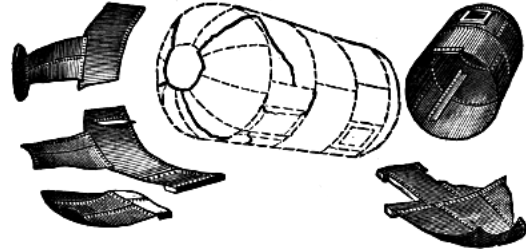

Fig. 13.

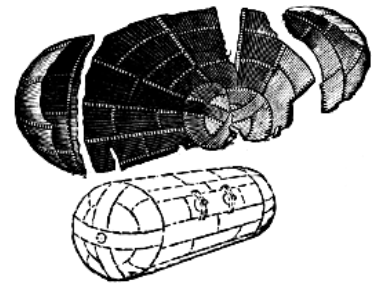

Fig. 14.

The following appear to be the general results to be derived from the experience of the explosions in this country during the last four years.

First as to faults of construction which fall under the department of the boiler maker or repairer. One of the most apparent causes of explosion in stationery boilers is the loss of strength occasioned by frequent repair, not only from the injury done to the old plates by removing rivets, but from the want of bond in the new work. This has lead to many of the explosions of the Plain Cylindrical boilers, such as are shown in [Fig. 15](#), [Fig. 16](#), and [Fig. 17](#), [No. 45, 1869](#), [No. 32, 1870](#), and [No. 20, 1870](#). Where the plates are arranged longitudinally instead of in rings, the danger is increased, as there is less chance of a dangerous rip being arrested by a crossed joint. So great a number of boilers with continuous longitudinal seams, especially in the North, have worked for twenty or thirty years, that it can hardly be supposed they are any weaker than the boilers made in rings; but they are more liable to explode, for if a seam rip occurs, it more easily extends along the seam, and leads to the general break up of the boiler, shown in [Fig. 18](#), [No. 59, 1869](#).

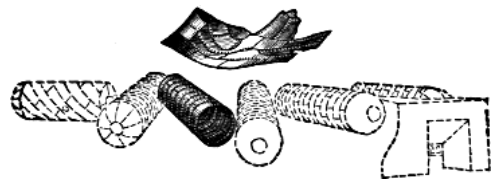

Fig. 15.

Perhaps no boilers have worked for a greater number of years than the Plain Cylindrical boilers, many specimens being in existence and apparently in good order which were put to work fifty or sixty years ago. When such boilers have been too much or injudiciously repaired, they are treacherous and uncertain; but their rupture and explosion occur not so much on account of fault of shape, as from the simple reason that like willing horses they are easily overworked. The grates are usually twice as large as the fair proportion to the heating surface, producing the double evil of forcing more heat through the iron plates over the fire than they can transmit without injury, and allowing a great amount of heat to pass away to the chimney without useful effect. Careful experiment shows that nearly as good duty can be obtained with the plain cylindrical boiler as with any other form, provided the rate of

combustion is in fair proportion to the extent of heating surface in the boiler. The circumstance that many plain cylindrical boilers have exploded is not sufficient to condemn this make of boiler, which is the cheapest, simplest, and most easily set. If the number of explosions alone were to be taken as the guide, it would lead to the condemnation of the Cornish and Lancashire boilers, from the experience of the past four years. But in case of both plain cylindrical and other forms of boilers, most of the dangers admit of remedy, and can be guarded against by frequent examination.

Five very fatal explosions have occurred of boilers heated by Puddling and Mill Furnaces, leading in some cases to the supposition that this form of boiler is more liable to explosion than others. They were not adopted however in the iron-making districts without great care and consideration, and there does not seem ground for attributing special danger to them. The causes of the five explosions referred to of these boilers were manifest, and would have led to the explosion of any form of boiler; the loss of life however was great, because the situation of the boilers was among a large number of workmen. The steam power required in ironworks so far exceeds that in any other trade, that an ironwork is half composed of boilers; the workmen are necessarily within the range of explosion of many boilers, and hence the great loss of life when such an accident occurs. The explosions of such boilers shown in [Fig. 19](#) and [Fig. 20](#), [No. 24, 1868](#), and [No. 31, 1868](#), were from external and internal corrosion respectively of the bottoms, rendering them too weak to bear the ordinary pressure.

Those shown in [Fig. 21](#) and [Fig. 22](#), [No. 23, 1870](#), and [No. 53, 1869](#), were from the collapse of the central tubes, which were weakened by external and internal corrosion respectively. In [Fig. 24](#), [No. 35, 1868](#), the shell was in bad order from over

work and receiving too much heat from four large furnaces, one of these especially causing a constant mass of flame to impinge upon a single plate, which resulted in a seam rip.

The greatest number of explosions and the greatest loss of life and personal injury have been in the case of Cornish and Lancashire boilers, or others with internal flues. In the county of Cornwall itself there have been many explosions, as often from the rupture of the shell, [Fig. 23](#), [No. 58, 1869](#), as from the collapse of the tube, [Fig. 25](#), [No. 35, 1869](#). The temporary patching on some of these old boilers was most extensive, [Fig. 26](#), [No. 52, 1869](#), and the only wonder really was that they held together as long as they did. The belief that shortness of water is the only cause which can lead to the collapse of tubes is so strong, that the boiler minders have often been condemned almost unheard in cases of explosion, as if there were no room for doubt that their neglect was the cause. Explosions from weakness of tubes are not however confined to Cornwall, as for example in [Fig. 27](#), [No. 42, 1868](#), where the flue was oval and very weak: although it was supposed that shortness of water caused the accident, from the idea that nothing else could account for it. The strain caused by the varying temperature of the internal tubes in Cornish or Lancashire boilers, and the difficulty of staying their flat ends so as to make them sufficiently secure without being too rigid to allow for the expansion of the tubes, render them liable to corrosion or "furrowing" in particular lines of strain, the destructive action

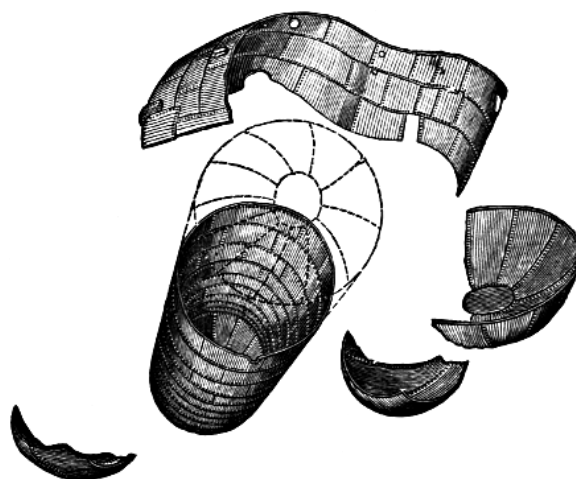

Fig. 16.

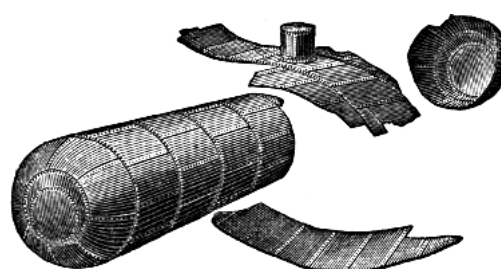

Fig. 17.

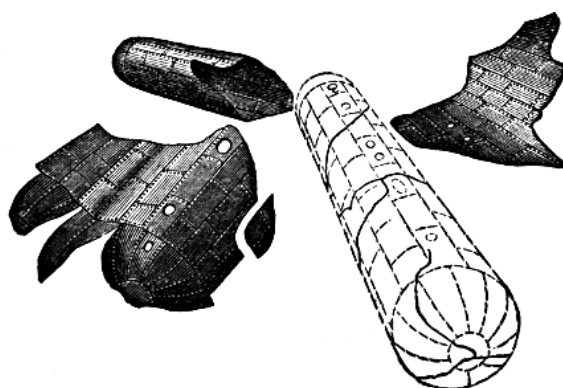

Fig. 18.

of which is very rapid; while the large quantity of brickwork around the outside, necessary to form the external flues, also renders them liable to corrosion in the parts most difficult of access. In this favourite form of boiler therefore careful and frequent examination in every part is more needed than in boilers of simpler form and setting; and the increasing number of explosions among these boilers seems to establish that they are only trustworthy if frequently examined and kept in perfect order.

Several instances have occurred of explosion of Portable Crane Boilers. Their small size has led to their condition being disregarded, under the idea that scarcely any pressure could burst them. In practice it is found however that they are often exposed to greater pressure than other boilers, because the fire is large and quick in proportion to their size; and they often have to stand for a considerable time with the steam up, and their exposed position and long intervals of rest add to the chances of corrosion, as shown by the example in [Fig. 28, No. 14, 1869](#). The large manholes without strengthening rings, that are so often put in these boilers, have been the cause of explosions such as that shown in [Fig. 29, No. 57, 1866](#).

The same remark applies to some of the portable or agricultural boilers which have exploded, such as those shown in [Fig. 30](#) and [Fig. 31, No. 43, 1868](#), and [No. 12, 1869](#).

Much mischief is often caused by bad imitation of well planned boilers. Thus in boilers of the Cornish form, the ends are made sometimes so rigid as to give no allowance for the expansion of the tube, and the result is such continued strain as to cause constant leaking and the consequent risk of fracture. In furnace boilers the tops of the crowns of the inside tubes are often made flat, as in [Fig. 37](#), instead of being domed; or the inside tube is of undue size, as in [Fig. 21, No. 23, 1870](#), see page 73. Furnace boilers have been made with the omission of the stays that are so peculiarly necessary in that form, whereby both ends have been left free to bulge outwards with the pressure, as in [Fig. 32](#).

Cornish boilers are often altered to the plain cylindrical form, without compensation being made for the loss of strength caused by the removal of the tube; this has led to such explosions as shown in [Fig. 33, No. 47, 1869](#), where two tubes were taken out, and [Fig. 34, No. 42, 1867](#), where one tube was taken out. One of the most frequent and serious causes of loss of strength is the repairing of externally fired boilers. Not only are the patches sometimes only bolted on in a temporary manner, as in [Fig. 35, No. 29, 1869](#), but even where they are rivetted on there is an entire want of bond or crossed joint, as in the case of the exploded boilers shown in [Fig. 15, Fig. 16](#), and [Fig. 17](#), see page 70 and 71, [No. 10, 1869](#), and [Fig. 36](#).

An attempt is made in [Fig. 38](#) to show the effect of wear and tear of boiler plate in an ordinary upright furnace boiler, such as is shown in [Fig. 37](#). The external surface is exposed to intense heat and consequently expands, while the internal surface is kept cool by contact with the water and expands to a much less degree. The continued repetition of this process produces the same effect of cracking the surface as that seen in the anvil blocks of steam hammers; and the strength of the plate is reduced in proportion to the destruction of the continuity of its surface. The deleterious effect of this process is much increased if the boiler is subject to alternate heating and streams of cold air on opening the fire-doors. To avoid it the flame should have room to spread over as large a surface as possible, without impinging on one particular point, and the firing should be as regular as possible; and hence the greater freedom from injury in boilers mechanically fired or heated by gas. The above action is quite distinct from the overheating of the plates that occurs when no water is in contact with them, which simply softens them and reduces their strength, as in [Fig. 39](#). It is believed that many boilers suffer from overheating without being short of water: and an attempt is made to show this action in such an upright boiler as is represented in [Fig. 37](#), page 78, by the enlarged section of the side shown in [Fig. 40](#). The flame is shown impinging on a limited surface, as before, and the steam rises so rapidly from the inner surface as to maintain a continuous stratum of steam between the iron and the water, and the plate consequently

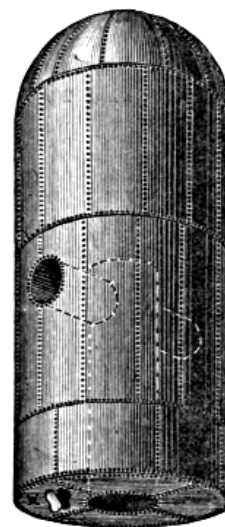

Fig. 19.

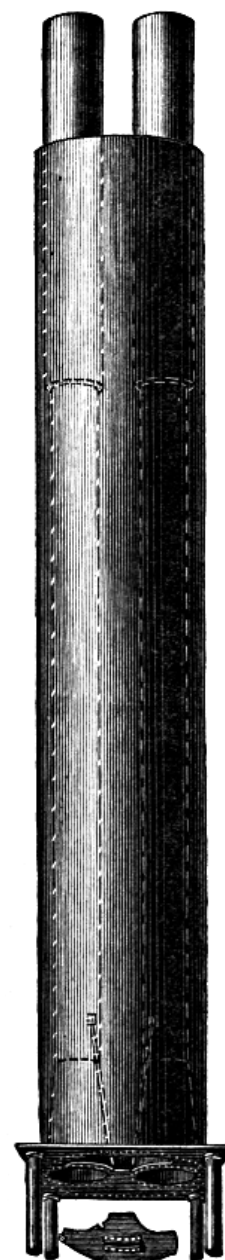

Fig. 20.

becomes overheated at that part. When the intense flame subsides by an alteration of the working of the furnace, the stream of steam diminishes, and the water returns and suddenly cools and contracts the plate, but often not before it has commenced to get out of shape. This has perhaps led to the explosion shown in [Fig. 59, No. 37, 1868](#), page 82. The same thing may happen to the crowns of tubes of internally fired boilers when over fired, as in [Fig. 41](#). Success has attended the use of internal linings to boilers, arranged so as to ensure a rapid circulation over the most heated parts, and also to catch all the mud and loose scale.

In order to enable boiler minders to make proper periodical examinations, it is necessary that care should be taken to arrange both the boilers and the flues with that view; and this can be done without materially injuring the efficiency of the boiler. Ordinary plain cylindrical boilers can be entered easily, as in [Fig. 42](#); and although the small spaces between the tubes and the shells of Cornish and Lancashire Boilers, as shown in [Fig. 43](#), render the complete examination troublesome, there is no difficulty in seeing those parts most likely to need examination, such as the crowns of the tubes and the end plates and angle iron. It is in the external flues that greater accommodation is needed, as in many cases these are so narrow that the boiler is quite inaccessible without pulling down the brickwork, as in [Fig. 44](#) and [Fig. 45](#). The loss of heating effect caused by the use of wider flues is so little, that it is far outweighed by the greater security obtained from the more efficient examination that is thereby rendered practicable. The flues of the plain cylindrical boiler are easily made wide enough for a man to pass through them. The flues of Cornish and Lancashire boilers should be made as shown in [Fig. 46](#) and [Fig. 47](#), so that a man can enter them without such inconvenience as in [Fig. 48](#). One point of danger being the use of wide mid-feather walls, on which corrosion is apt to take place, these should be narrowed and the weight of the boiler supported on side brackets; the top of the mid-feather and side walls can then be constructed with sight holes as at **A A** in [Fig. 49](#) and [Fig. 50](#), so as to give the means of examining the plates near each seam by simply removing loose bricks.

The explosions of fourteen Domestic or Heating-Apparatus Boilers are included in the list of explosions, [Table III](#); and some notice is required to be taken of these, because they have led to the loss of the lives of those who could not be expected to know their construction or how to guard against accident; and as these boilers are seldom seen or examined after they are once set, they should be the more carefully constructed. In one or two cases these boilers were of a rectangular shape, as in [Fig. 51, No. 41, 1868](#), ill adapted to bear internal pressure, and yet placed in connection with cisterns in the roofs of lofty houses, so as to expose them to a hydrostatic pressure almost up to their bursting strength without any addition of steam pressure. The most usual cause of explosion is the lighting of the fire during frosty weather in a house that has been left vacant, so that steam pressure accumulates in the boiler whilst the exit is frozen up, as was the case in [Fig. 52, No. 6, 1870](#).

The cast-iron boilers commonly used, [Fig. 53](#), end of 1869, are capable of bearing but little pressure; and the wrought iron boilers, as in [Fig. 54, No. 7, 1870](#), are found often so badly welded as to be but little stronger; but even if they were as strong as they could be made, the stoppage of the pipes by ice would lead to explosion. Steam pressure may be guarded against by a safety valve; but as this may become set fast in a little time, it would be far better

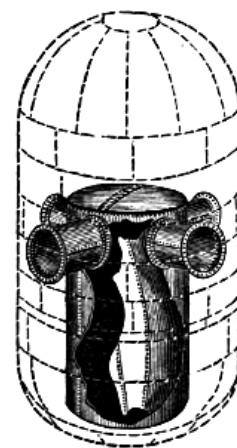

Fig. 21.



Fig. 22.

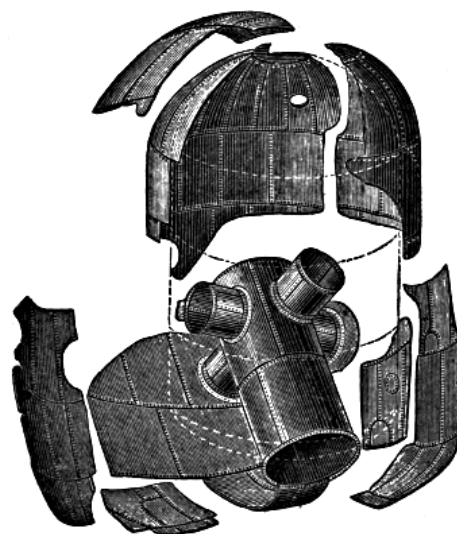

Fig. 24.

to avoid all chance of steam accumulation by such an arrangement as that shown in [Fig. 55](#), where the circulating boiler is placed within an open-topped boiler behind the kitchen fire, and only receives its heat through the hot water surrounding it, and therefore cannot itself become sufficiently hot to generate steam.

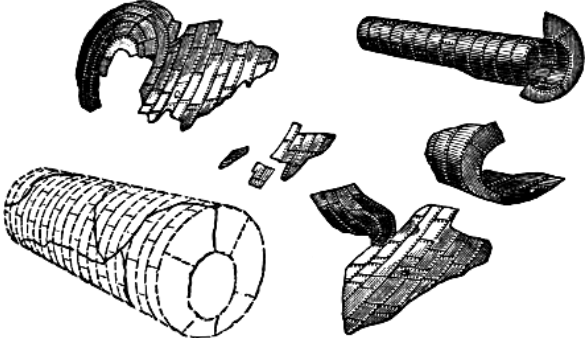

Fig. 23.

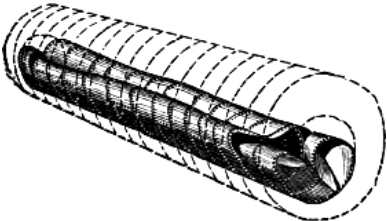

Fig. 25.

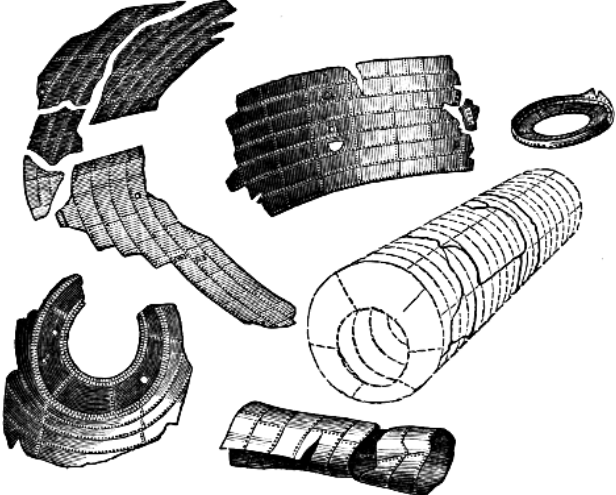

Fig. 26.

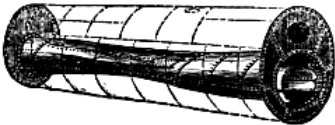

Fig. 27.

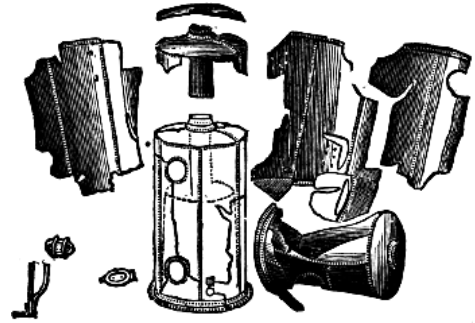

Fig. 28.



Fig. 29.

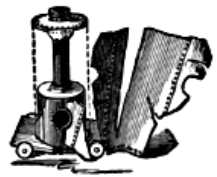

Fig. 30.

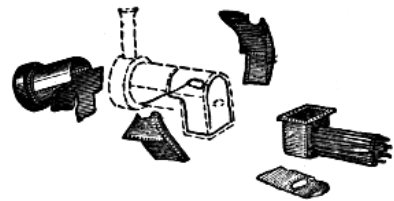

Fig. 31.

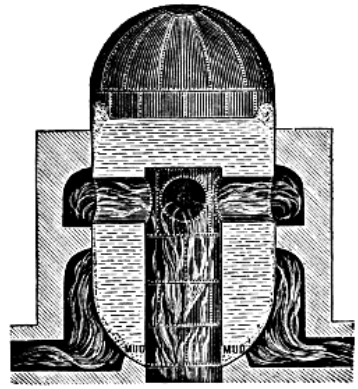

Fig. 37.

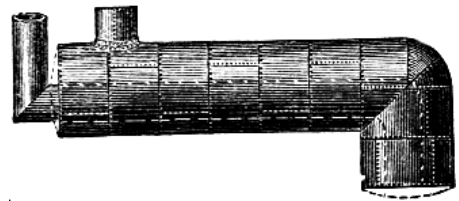

Fig. 32.

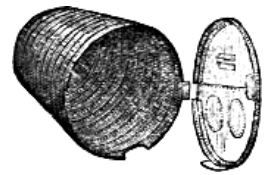

Fig. 33.

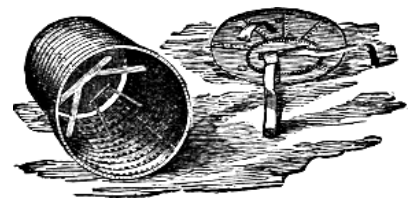

Fig. 34.

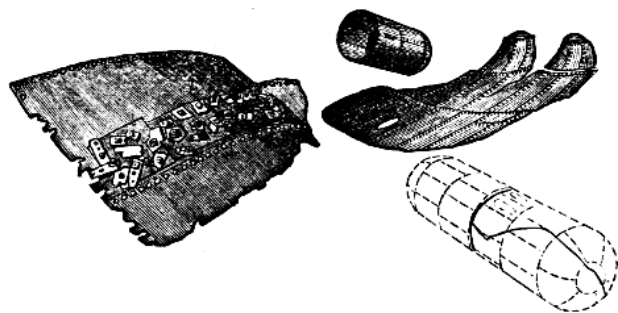

Fig. 35.

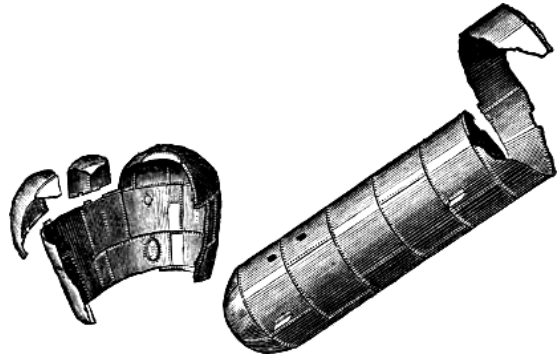

Fig. 36.

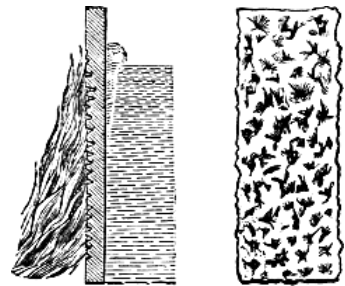

Fig. 38.



Fig. 39.

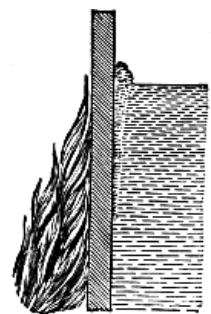

Fig. 40.

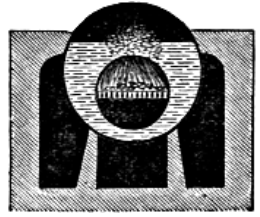

Fig. 41.

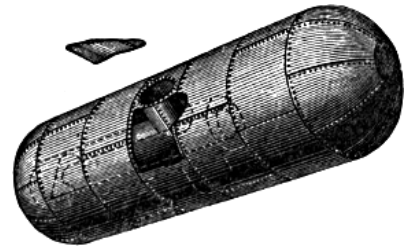

Fig. 59.



Fig. 42.

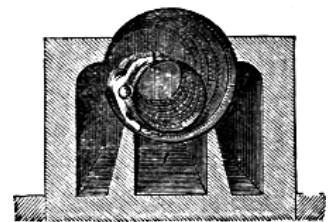

Fig. 43.

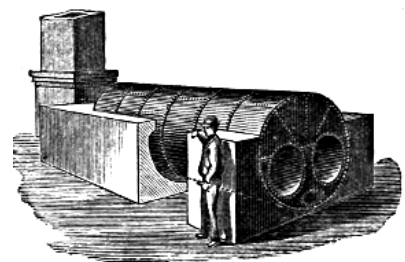

Fig. 44.

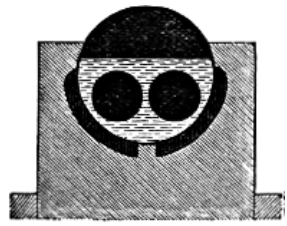

Fig. 45.

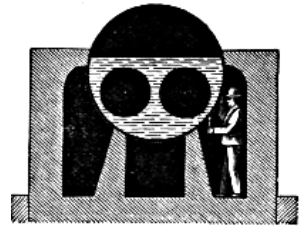

Fig. 46.

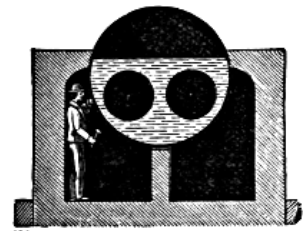

Fig. 47.

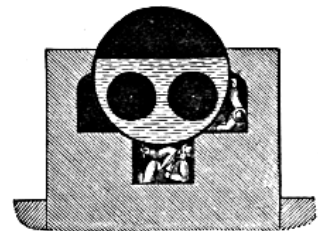

Fig. 48.

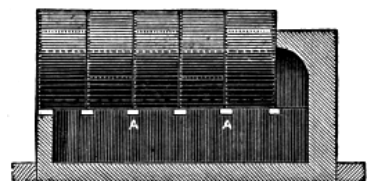

Fig. 49.

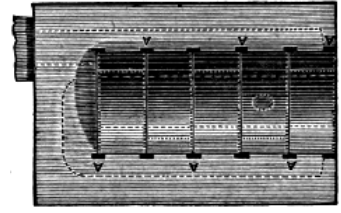

Fig. 50.

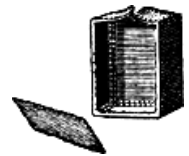

Fig. 51.

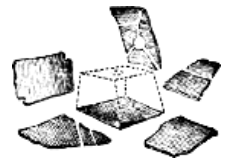

Fig. 52.

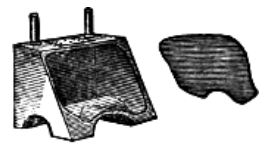

Fig. 53.

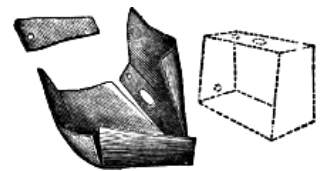

Fig. 54.

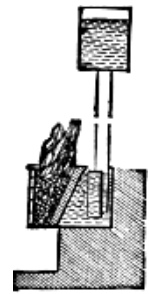

Fig. 55.

A few remarks may be useful as to those faults arising in working which fall under the department of the boiler minders. Not a few of the explosions during the last four years have occurred from acts of simple carelessness, such as where a blow-off pipe was left open, so that the boiler was nearly emptied of water while at work; or in another case where two boilers were fed at the same time through a common pipe without a back valve, and the water from one "kicked" over into the other. Undue pressure has been allowed to accumulate by safety valves being tied down, as in the agricultural boiler, [Fig. 56, No. 16, 1867](#); or by an extra weight being put upon the safety valve, as in an instance where three bricks were fastened to the lever and the fires were lighted earlier than usual, under the idea that an accumulation of steam could be raised during the night to make a good start in the morning. Another explosion was caused by working a boiler at more than three times its proper pressure to meet a temporary emergency. In not a few cases of explosion there was no pressure gauge on the boiler, or the gauge was out of repair in consequence of being placed on the steam pipe, so that it vibrated with every stroke of the engine; as in the examples shown in [Figs. 24 and Fig. 16, No. 35, 1868, No. 32, 1870](#), pages 70 and 74.

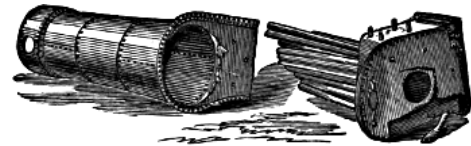

Fig. 56.

Corrosion has been the direct cause of many of the explosions. In one or two cases the corrosion was known to exist, but the renewal of the boiler was too long delayed, as in [Fig. 57, No. 8, 1869](#), in others it took both owners and minders by surprise, as in [Fig. 1, No. 12, 1870](#), page 63. It is said that to produce rapid rusting of iron there must be present oxygen, water, and carbonic acid; and as all these are present in a boiler flue when there are leaks, it is not surprising that so many cases occur of explosions from corrosion.

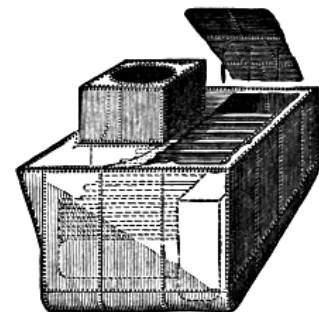

Fig. 57.

Much mischief is often done by the injudicious use of compositions in the boiler that are designed to prevent incrustation, especially where there is no blow-off cock or where its use is neglected. A hard deposit on the boiler plates is, in the writer's opinion, not so injurious as the soft and muddy deposit produced by the use of such compositions. A hard scale is equivalent to thickening the plate; and although this is sufficiently mischievous, the injury to the plates is much more rapid when a thicker but spongy deposit entirely prevents contact of the water and impedes the transmission of the heat. An attempt to illustrate this is given in [Fig. 58](#), which is an enlarged view of a portion of such a boiler as is shown in [Fig. 37](#). The money spent in boiler compositions would be better applied in securing a supply of proper water, or in filtering and purifying the water before it enters the boiler.

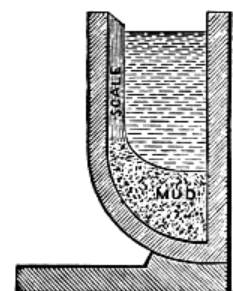

Fig. 58.

The writer has had to mention only faults in boilers; but it is not to be inferred that all boilers are working in actual danger. A very small percentage perhaps are so; but without periodical examination no one can feel sure of the condition of any boiler. It is not likely that explosions in future will be from exactly the same causes as those now described, because the known

internal flues	140	1	141	84	3	87	224	4	228
Locomotive	91	29	120	10	68	78	101	97	198
Plain Cylindrical externally fired	114	2	116	54	3	57	168	5	173
Balloon, Haystack, Wagon, Butterley, British-Tube Elephant, or Trevithick	62	2	64	5	2	7	67	4	71
Portable, Agricultural, Upright, Crane, or very small	28	1	29	17	17	34	45	18	63
Heating, Kitchen, Domestic, Rag Steamers, &c.	14	..	14	22	14	36	36	14	50
Furnace-upright	10	..	10	8	..	8	18	..	18
Not sufficiently described to be classified	203	29	232	7	175	182	210	204	414
Totals	719	327	1046	219	346	565	938	673	1611

TABLE II.

Summary of Records of Steam Boiler Explosions up to 30th June, 1870, showing Causes of Explosions.

Cause of explosion.	Explosions up to June 1866.			Explosions in the 4 years from June 1866 to June 1870.			Total Explosions up to June 1870.		
	English.	Foreign.	Total.	English.	Foreign.	Total.	English.	Foreign.	Total.
Worn out, corroded, or burnt plates	92	53	145	89	5	94	181	58	239
Undue pressure, overloaded valves, intentional or from carelessness	132	5	137	25	6	31	157	11	168
Bad construction, weak tubes, defective fittings or stays, or want of repair	136	108	244	69	8	77	205	116	321
Shortness of water, formation of scale or mud, or external flues set too high	106	8	114	28	2	30	134	10	144
Extraneous causes, lightning, fire, gas, &c.	6	3	9	2	..	2	8	3	11
Too uncertain to be classified	247	150	397	6	325	331	253	475	728
Totals	719	327	1046	219	346	565	938	673	1611

TABLE III.

Analysis of Steam Boiler Explosions in the United Kingdom during the Four years ending 30th June, 1870, showing the Causes of Explosion of Boilers of different descriptions.

A Faults in construction or repair.

B Faults which should be detected by periodical examination.

C Faults which should be prevented by careful attendants.

D Causes extraneous or uncertain.

E number of Explosions.

K number of persons Killed.

I number of persons injured.

CORNISH, LANCASHIRE, or other Boilers with internal flues.

	E	K	I
Weak Tubes	26	17	41
Weak combustion chambers	5	8	7
Weak ends	3	10	10
A Weak dome	1	0	0
Weak manhole	1	1	1
Bad repair	3	5	2
	39	41	61
External Corrosion	18	42	101
B Internal Corrosion	6	4	5
	24	46	106
Shortness of Water	14	11	23
Scale of mud	3	1	0
C Undue Pressure	4	14	4
	21	26	27
	84	113	194

PLAIN CYLINDRICAL, or other Boilers without internal flues.

	E	K	I
Weak flat ends	8	9	12
Weak manhole	1	0	2
A Frequent repair producing seam rip in boilers with plates arranged lengthways	15	18	28
Do. with plates arranged in rings	8	11	25
	32	38	67
External Corrosion	11	5	19
B Internal Corrosion	5	5	6
	16	10	25
Shortness of Water	2	1	0
Scale	1	1	0
C Undue pressure	3	4	3
	6	6	3
	54	54	95
Carried forwards	138	167	289

MARINE BOILERS.

	E K I			
Weak flues	3 6 3			
Weak ends	2 6 5			
A Bad material	1 3 1	E K I		
		6 15 9		
External Corrosion	2 10 3			
B Internal Corrosion	3 1 4			
		5 11 7		
C Shortness of water	1 11 7			
		1 11 7		
			12 37 23	

LOCOMOTIVE BOILERS.

A Boiler used as frame for engine	2 1 2			
		2 1 2		
External Corrosion	2 1 4			
B Internal Corrosion	2 0 3			
		4 1 7		
Broken connecting-rod pierced boiler	1 2 1			
D Dome caught by railway bridge	1 1 0			
Uncertain causes	2 0 4			
		4 3 5		
			10 5 14	

AGRICULTURAL BOILERS.

A Weak manhole	1 1 4			
		1 1 4		
External Corrosion	2 3 3			
B Internal Corrosion	1 1 7			
		3 4 10		
Shortness of water	1 0 0			
C Undue pressure	6 15 15			
		7 15 15		
			11 20 29	

FURNACE UPRIGHT BOILERS.

Too much flame on one part	1 2 0			
A Frequent repair producing seam rip	1 13 2			
		2 15 2		
External Corrosion	2 13 11			
B Internal Corrosion	2 15 6			
		4 28 17		
C Shortness of Water	2 3 8			
		2 3 8		
			8 46 27	

ELEPHANT BOILERS.

A Weak ends or want of stays	1 2 2			
		1 2 2		
B External Corrosion	1 0 4			
		1 0 4		
			2 2 6	
			Carried forwards 181 277 388	

CRANE BOILERS.

	E K I			
A Weak manhole	3 7 3	E K I		
		3 7 3		
B External Corrosion	1 4 2			
		1 4 2		
C Shortness of water	2 2 0			
		2 2 0		
			6 13 5	

RAG STEAMERS, &C.

Weak manhole	3 2 5			
Bad material	1 1 5			
A Want of stays	1 1 0			
		5 4 10		
C Undue Pressure	1 2 6			
		1 2 6		
			6 6 16	

FEED-WATER HEATERS.

D Uncertain causes	2 0 6			
		2 0 6		
			2 0 6	

DOMESTIC BOILERS.

A Weak shape	3 4 7			
		3 4 7		
B Corrosion	2 0 5			
		2 0 5		
C Undue Pressure from freezing of Pipes	9 7 9			

		9 7 9		
			14 11 21	
BALLOON BOILERS.				
B External Corrosion	2 1 2	2 1 2		
C Undue Pressure	1 1 0	1 1 0		
			3 2 2	
BOILERS OF UNCERTAIN DESCRIPTION.				
A Weak manhole	1 0 0	1 0 0		
Steam entered through blow-off pipe from another boiler while cleaning	1 1 2			
C Steam pipes broken	2 4 3			
Shortness of Water	1 1 4			
		4 6 9		
D Uncertain causes	2 0 3	2 0 3		
			7 6 12	
			E K I	
			TOTALS 219 315 450	

TABLE IV.

Summary of causes of the Steam Boiler Explosions comprised in Table III.

Causes of Explosion.	E Number of Explosions.	K Number of persons Killed.	I Number of persons Injured.
A Faults in construction or repair	95	128	167
B Faults which should be detected by periodical examination	62	105	185
C Faults which should be prevented by careful attendants	54	79	84
D Extraneous or uncertain causes	8	3	14
Totals	219	315	450

BRIEF ABSTRACTS

FROM REPORTS ON

STEAM BOILER EXPLOSIONS,

PRESENTED TO THE

**MIDLAND STEAM BOILER INSPECTION &
ASSURANCE Co.,**

BY

EDWARD BINDON MARTEN,

CHIEF ENGINEER TO THE COMPANY.

Description is shortened as much as possible, and facilitated by slight sketches, showing the position of the fragments or line of fracture, and the general construction of the Boilers.

REPUBLISHED BY THE PERMISSION OF THE COMPANY.

STOURBRIDGE: B. BROOMHALL, PRINTER, HIGH STREET.

1869.

BOILER EXPLOSIONS IN 1866.

No. 1. Nottingham.

January 1st.

none injured.

Locomotive, 110 lbs., standing with steam up near a platform. All but the fire box was blown away, the main portion being thrown a distance of 400 yards. The first rent took place at a longitudinal seam of the barrel where grooving had gone on very rapidly, which was not discovered when examined and tested a short time before.

No. 2. Walsall. ([Fig. 1.](#))

January 2nd.

2 injured.

Butterley, 26ft. 6in. long, and 9ft. diameter. The wagon-shaped top to the fire place was 8ft. 6in. long, and was attached to the bell-mouth of the internal tube, which then continued circular to the back of the boiler. The tube was 3ft. 6in. diameter. All the plates were about 7-16ths inch thick, and although the boiler was an old one, they were nowhere reduced in thickness by wear. The usual pressure of steam was 18 lbs., and a self-registering gauge showed that at the time of explosion it did not exceed 20 lbs.

The top of the fire grate on the right side rent longitudinally, and the upper part of the shell consisting of four rings of plates, and also the top of the fire place opened out and blew away to a considerable distance.

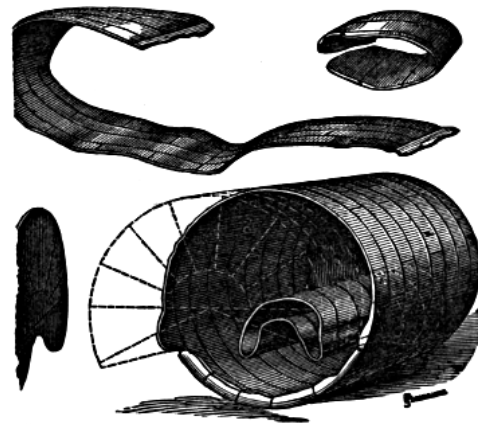

Fig. 1.

The front end also blew away. The bell-mouth of the tube was blown to the front, and the tube which remained in the back part of the shell collapsed upwards.

The cause of the explosion was most likely the intrinsic weakness of boilers of this shape, especially over the fire, where the top is only retained in its shape by numerous stays. The boiler had been very frequently repaired, at this the weakest place, and its strength had been thus so reduced as to make it unable to bear even a few pounds more than the ordinary working pressure.

The whistle was found to have been gagged by hemp, carefully inserted, so that there is ground for supposing there had been intentional unfair usage.

No.3. Blyth. ([Fig. 2.](#))

January 8th.

1 killed 1 injured.

Marine, 20ft. long, and 5ft. diameter, with internal fire place and return flue, 14 lbs. There were altogether three rents in the tube over the fire, as a small band was held in its place by a stay from the tube to the shell. The escaping contents scalded those near, but no damage was done to anything but the boiler.

The cause was stated to be shortness of water. There was no water gauge.

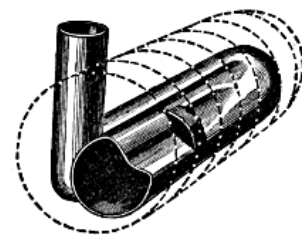

Fig. 2.

No.4. London.

January 9th.

1 killed.

One tube Cornish, 28ft. long, 6ft. 6in. diameter, with one tube 3-6 diameter, 3/8 inch plates, 45 lbs.

The tube collapsed in an incline direction from weakness without strengthening rings.

The appearance after explosion was nearly the same as that shown in sketch given at [No. 12](#) explosion.

No.5. Glasgow. ([Fig. 3.](#))

January 13th.

4 killed, 4 injured.

Two tube Cornish, 22ft. 3in. long, and 7ft. 7in. diameter, 3/8 inch plates, tubes 2ft. 7in. diameter, 40 lbs.

About 8ft of the back portion of the shell was torn off, leaving the tubes and ends intact.

The cause of the explosion was considered to be excessive pressure, but how accumulated did not transpire.

It is most natural to expect that there must have been corrosion under the bottom to cause the first rent.

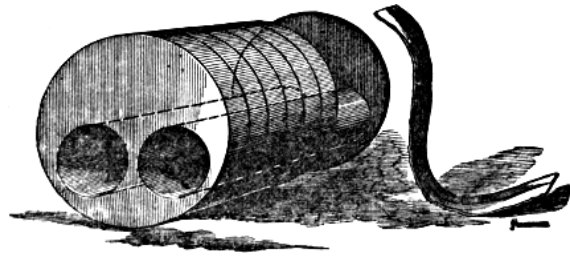

Fig. 3.

No.6. Coatbridge.

January 17th.

1 injured.

Cornish. No details have been obtained.

No.7. York. ([Fig. 4.](#))

January 18th.

1 killed, 2 injured.

Agricultural, 8ft. 2in. long, 3ft. 6in. diameter in the barrel, 5-16ths inch plates, internal fire box, 2ft. 4in. wide, 2ft. 4in. high, and 2ft. 10in. deep. From the back of this fire box, two 12-inch tubes passed to an internal chamber at the back of the barrel. From this again passed nine 3¾ inch tubes to an exterior smoke-box fixed over the fire door. The boiler was fitted with one spring safety valve, which was screwed down tight, but there was no pressure gauge. The front plate was intended to be bolted on so that the fire-box and tubes could be taken out for cleaning, but it had been rivetted, leaving no means of cleaning, and it was nearly full of scurf.

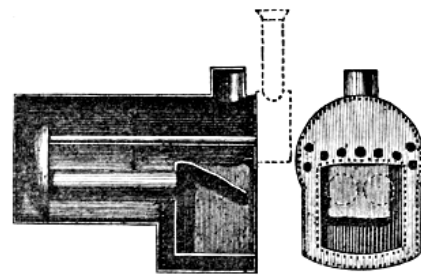

Fig. 4.

The crown plate of fire-box which was too flat and unstrengthened, rent at the front and along both top edges, and was driven into the fire. The boiler was thrown backwards and reared against a wall, resting on the front right hand corner.

The cause of the explosion was that the very dirty state, caused overheating where the water was not in proper contact with the plates, and the defective construction did not admit of proper cleaning. The mountings were insufficient for the proper protection of the boiler.

No.8. Durham. ([Fig. 5.](#))

January 29th.

1 killed, 3 injured.

Plain Cylinder Boiler with hemispherical ends, 30ft. long and 6ft. diameter, 3/8 inch plates, 30 lbs. It was the second from the engine in a bed of five, and had been at work three years, then remained idle for eight years, working again fourteen years. The boiler was mounted with two safety valves 3-7/8 and 4 inches diameter, a float and alarm whistle. The boiler had been more than once repaired over the fire with several new plates. One seam over the fire had been observed to leak about a week before the explosion, but not seriously, and had been caulked. The boiler had just been started after cleaning. Six months before explosion, the boiler had been tested to 69 lbs.

About 5 feet of the front end of the boiler opened out flat, and was thrown to the rear about 60 yards; the front hemispherical end was liberated and thrown 20 yards also to the rear and right hand. The back part of the boiler was thrown in a mass, and after bounding twice, lodged at a distance of 230 yards.

The cause of the explosion appeared to be from the failure of a seam over the fire place in a plate

deteriorated by age, and overheated through a deposit of scurf and mud.

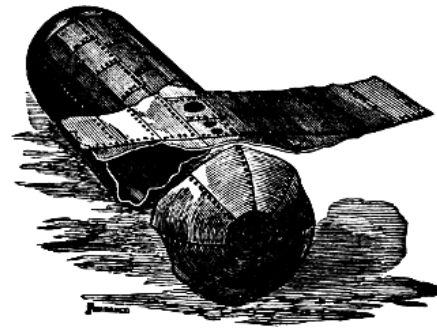

Fig. 5.

No.9. Birmingham. (Fig. 6.)

February 7th.

1 killed, 4 injured.

Plain Cylindrical Boiler, with hemispherical ends, 23ft. long, and 5ft. diameter, $\frac{3}{8}$ inch plates, 50 lbs. It was set so as to be fired under the bottom if required, but the grate was seldom used. The principal heat was supplied from a mill furnace, the neck of which was at the left hand of the back, and the flame was carried by a wheel flue round the front of the boiler to the stack on the right hand side of the back. The boiler was fitted with a $4\frac{3}{4}$ -inch safety valve, and also a float, but it was suspected that the latter had broken from the rod.

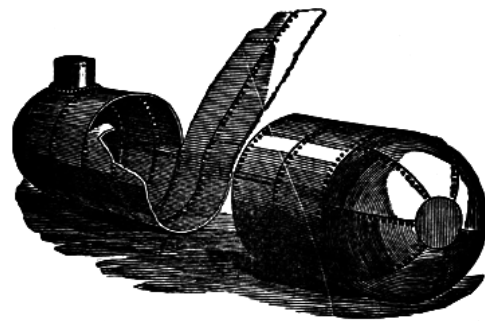

Fig. 6.

A horizontal seam about the middle of the left hand side had given way, and the upper portion of the 3rd and 4th rings of plates had spread out like a lid without being detached from the boiler. The front end became detached and was thrown some distance to the front.

The cause of explosion was, that the left side of the boiler became overheated, and so much softened, that it first bulged outwards with the ordinary working pressure, and then rent open. The overheating was most likely the result of shortness of water, but it might possibly have been in consequence of the intense heat of a mill furnace impinging on a small area so near the water line, leading to such rapid ebullition as to prevent sufficient contact of the water to keep the plates cool.

No.10. Dunse.

February 14th.

1 injured.

Locomotive. It exploded while standing in a shed, but no particulars have been obtained.

No.11. Middlesbro'.

February 26th.

1 injured.

Marine, in a small tug boat, but no details have been obtained.

No.12. Gainsbro' (Fig. 7)

February 26th.

1 injured.

One Tube Cornish, 21ft. long, 5ft. diameter, with one tube 2ft. 11in. diameter, plates $\frac{3}{8}$ inch, 64 lbs. There were no strengthening rings on the tube. The boiler was second-hand, and had only worked a part of a day at its new position when it exploded.

The tube collapsed from weakness without strengthening rings.

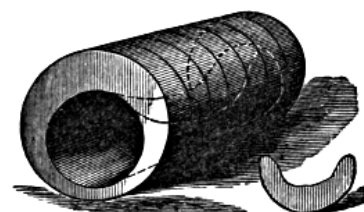

Fig. 7.

No.13. Redruth. (Fig. 8.)

March 3rd.

1 killed.

One Tube Cornish, 31ft. 9in. long, and 5ft. 9in. diameter, tube 3ft. 8in. diameter, 3/8 inch plates, 40 lbs.

The tube had been repaired with a bolted patch on the left side the day before the explosion, and it is presumed it was slightly out of the circular shape, as it collapsed sideways, the top being thrown up above its proper height. There was no evidence of shortness of water.

The tube without strengthening rings was too weak to sustain the ordinary working pressure.



Fig. 8.

No.14. London.

March 5th.

7 injured.

Cornish, at 27 lbs., but as the boiler was not injured, it is only noticed as an explosion, because of the imprudence of placing fittings in such dangerous positions. The boiler was beneath a work room, and the lever of the safety valve became displaced, allowing the valve to blow out, and the escaping steam rushed into the room above and scalded seven men very badly.

No.15. Manchester.

March 6th.

1 killed.

This was a Boiler with two internal fireplaces, connected into one flue at the back.

The crowns of both furnaces were collapsed, and slightly rent, and the escaping steam and water scalded the attendant.

The water was 8 or 9 inches below its proper level, allowing the furnace crowns to become overheated and unable to bear the working pressure.

Each furnace had been fitted with a fusible plug, but they proved inefficient.

No.16. Norwich. ([Fig. 9.](#))

March 13th.

1 killed, 1 injured.

This was a very small boiler, 8ft. long, and 3ft. 2½in. diameter, with two small tubes. It was fired externally.

The dome was blown off and the rents continuing, the top opened out on each side, and the upper portion of both back and front was bent back.

The dome cut away the whole of the top plate, and so much reduced the strength that it would not bear the ordinary working pressure.

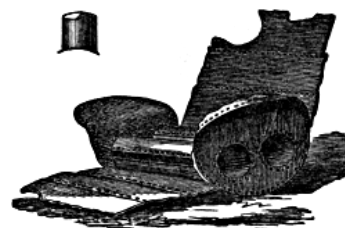

Fig. 9.

No.17. Dudley. ([Fig. 10.](#))

March 19th.

none injured.

Plain Cylinder Boiler, 36ft. long, 5ft. 6in. diameter, 60 lbs. It had frequently been repaired over the fire, so that the longitudinal seams ran for several plates without break of joint. A patch had been put on a few days before explosion, and as the rivet holes had badly fitted, there had been much strain caused by drifting, and the rivets were much distorted.

A longitudinal seam gave way over the fire, when two rings of plates opened out, rending the transverse seams at each side until completely separated, and fell in two parts at a distance of about 100 yards in front of the boiler. The front end was liberated and fell in one piece about 100 yards beyond the two pieces of the shell. The main body of the boiler was driven back a few yards and rolled over so as to be upside down, but was little injured.

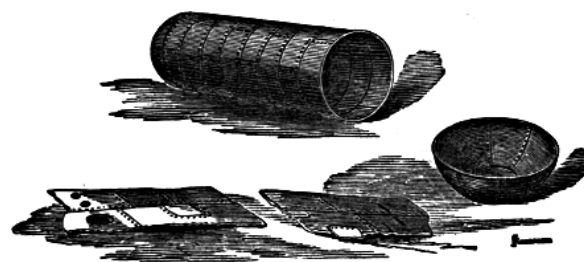

Fig. 10.

The frequent and badly executed repair over the fireplace, had so weakened the structure as to make it unable to bear the very high ordinary pressure. This frequent repair over the fireplace had been made necessary by very hard firing and deposits of scurf from muddy water, preventing the proper contact of the water with the plates.

No.18. Liverpool.

March 22nd.

1 killed.

This was a small Boiler to supply steam for some steam winches on board a steam boat, and exploded from the overheating of the upper tubes through shortness of water, or from over pressure in consequence of having only one safety valve.

No.19. Leeds. (Fig. 11.)

March 27th.

2 killed, 18 injured.

Two Tube Cornish, 24ft. 6in. long, 6ft. 6in. diameter, tubes 2ft. 6in. diameter, 3/8 inch plates, 54 lbs., fitted with steam gauge, blow-off cock, 1½ inch dead weight safety valve, loaded to 54 lbs., and 4-3/8 inch lever safety valve, loaded to 62 lbs., and had been at work about five years.

Nearly the whole of the two back rings of the shell were torn off and opened out, and the boiler was turned partly round, and moved upon its seat sideways and forwards.

There was extensive corrosion at the under side of the back of shell, where the first rent took place, caused by the leaking of the joints and seams.

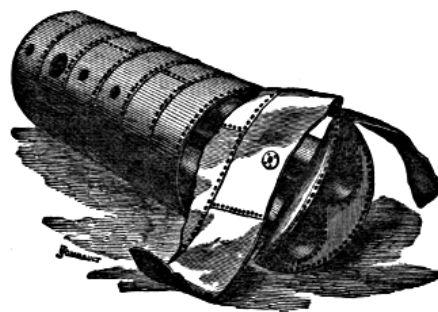

Fig. 11.

No.20. Swansea. (Fig. 12.)

April 4th.

5 killed, 4 injured.

One Tube Cornish Boiler, 30ft. long, and 7ft. diameter, tube slightly oval about 4ft. diameter, 7/16 inch plates, 43 lbs., fitted with 3½ inch safety valve, which is much too small for such a boiler, glass water gauge, two gauge cocks, and pressure gauge.

The tube collapsed from end to end. The front end was blown out with a short length of the tube attached, and was driven against a wall about 30 yards to the front. The main body of the shell, and the back end, with the collapsed tube within it, were driven back against another wall, about the same distance away. Very great damage was done to the surrounding property.



Fig. 12.

The cause of the explosion was the weakness of the tube of so large a diameter, without strengthening rings, which made it unable to bear the ordinary working pressure. It is very probable, however, that at the time of the explosion, the pressure was considerably more than usual during the stoppage of the engine, and the confusion caused by a man becoming entangled in the machinery.

No.21. Morpeth.

April 10th.

1 killed.

Plain Cylinder Boiler, 34ft. long, and 5ft. diameter, 3/8 inch plates placed lengthways, 33 lbs.

The explosion took place at a seam in the front part of the bottom of the boiler just over the fire. This rupture allowed the sides to expand, until the boiler was completely destroyed and torn into seven pieces.

The cause of the explosion was supposed to be the defective state of the seams over the fire, which, being placed longitudinally, were in the weakest position.

Two Tube Cornish, 15ft. long, 6ft. diameter, tubes 1ft. 8in. diameter, 3/8 inch plates, 40 lbs. The heat was supplied by two furnaces, one of which played into each tube.

The left hand tube collapsed from shortness of water, and tore away from the angle iron in the front plate, and allowed the contents to issue violently and scatter the brickwork, but the boiler was not disturbed.



Fig. 13.

No.23. Burnley.

April 26th.

2 killed, 2 injured.

Small internally fired Boiler, 5ft. high, 2ft. 4in. diameter, and was intended to work at 70 lbs. The fittings were defective, the spiral spring of the safety valve being most easily altered, so as to cause over pressure. The manhole was not strengthened by any ring, and the first rents commenced at that point.

The cause of the explosion was over pressure and defective construction.

The sketch at [No. 57](#) explosion in this year, is of a similar boiler which exploded from nearly similar causes.

No.24. Bilston. ([Fig. 14.](#))

May 13th.

none injured.

Balloon or Haystack Boiler, about 16ft. diameter, 5/16 inch plates, and worked at very little above atmospheric pressure.

The boiler was chiefly used to store water during the time another boiler by the side of it was emptied. When the water was required to refill the other boiler, a fire was lighted under the balloon, and sufficient steam generated to drive the water from it into the other boiler. The safety valve never being used, it had become fast, and as a little more steam than usual had accumulated, the bottom gave way, and the reaction of the issuing contents made the boiler rise from its seat, and it fell on its side at some distance away flattened by the fall.

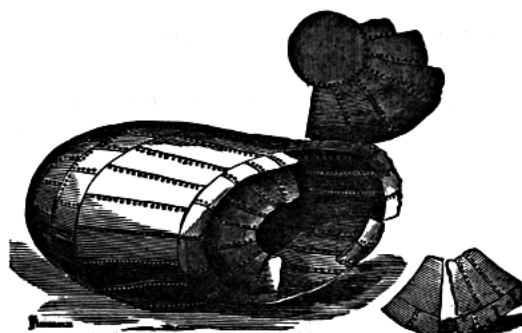

Fig. 14.

No.25. Westbromwich. ([Fig. 15.](#))

May 25th.

none injured.

One Tube Cornish Boiler, 15ft. long, and 4ft. 6in. diameter, taper tube, 2ft. 9in. diameter in front, and 2ft. diameter at back, 3/8 inch plates, 40 lbs. The boiler rested on two walls forming the bottom flue. There was a safety valve, a glass water gauge, a pressure gauge, and two fusible plugs upon the tube.

Two longitudinal rents took place on the under side of the shell, allowing two strips, forming the central part, to open out by the continuation of the fracture, until they were blown to a considerable distance. The tube with the front end, and one ring of the shell were thrown to the front, while the back end was thrown to the rear, the smallest end of the tube having torn away from the back.



Fig. 15.

The shell was deeply corroded where it rested on the side walls of the bottom flue, and the strength

of the boiler was thereby so much reduced, that it was unable to bear the ordinary working pressure.

No.26. Halifax. (Fig. 16.)

May 26th.

1 killed.

One Tube Cornish, 24ft. 6in. long, and 5ft. diameter, taper tube, slightly oval in the front, 2ft. 8in. diameter, and 2ft. diameter at the back, 3/8 inch plates. The boiler was fitted with glass water gauge, float, self-acting feed apparatus, and safety valve loaded to 52 lbs., and also a mercury gauge.



Fig. 16.

The tube collapsed over the fire, a rent taking place in the second ring of plates. The issuing steam and water caused the death of a man in front, but the shell of the boiler was not injured or moved.

The cause of the explosion was shortness of water, and as the glass gauge was set unusually low, the man in charge may have been deceived. The oval shape of the fireplace, and the laminated iron, as shown in the fracture, rendered the tube peculiarly liable to collapse.

No.27. Durham.

May 26th.

1 killed.

Plain Cylinder Boiler, 34ft. long, 5ft. diameter, 3/8 inch plates, 45 lbs., fitted with two 5-inch safety valves, and 2 floats.

The boiler was torn in two pieces, that were thrown to a considerable distance. The first rent had taken place immediately over the fire.

The cause of the explosion was the weakening of the shell by frequent repair over the fire, rendered necessary by the deposit from the muddy water preventing proper contact of the water with the plates.

No.28. Durham.

May 27th.

1 killed.

Plain Cylinder Boiler, 32ft. long, 6ft. diameter, 3/8 inch plates, 35 lbs., fitted with two safety valves, two floats, and two alarm whistles.

The boiler was lifted from its seat, and one end was separated and thrown to a considerable distance.

The cause of the explosion was weakening of the shell from repair a few days before, and perhaps over pressure, as the gauge was found some time after, and indicated that the pressure had at some time exceeded 80 lbs.

No.29. Redruth.

May 28th.

1 killed, 4 injured.

One Tube Cornish, 30ft. 8in. long, 6ft. 8in. diameter, tube, 4ft. diameter, 7/16 inch plates, 40 lbs.

The tube collapsed, and rent, and the issuing steam and water scalded those near, as it was too weak to bear the ordinary working pressure.

No.30. Leicester. (Fig. 17.)

May 31st.

1 killed, 1 injured.

Plain Cylinder Boiler, with dished ends, and only 4ft. 2in. long, and 2ft. 6in. diameter, 1/4 inch plates. It was most inefficiently mounted, the safety valve was only 1-5/8-inch diameter, and of such faulty construction, that it would not open under a pressure of 162 lbs. There was no steam gauge or float, and the gauge cocks were defective. There was no means of putting water in the boiler when there was a pressure of steam. The manhole was very large for so small a boiler.

Four rents started from the manhole and continued along the top of the boiler and round the end seams. A tongue-shaped strip of the top plate was attached to the back end plate; two strips about a foot wide on either side were blown away. The boiler had been turned nearly round in its flight, and fell with the back about 12 feet from the original position of the front.

The boiler was worked until it was nearly dry, and, during a temporary stoppage of the engine, an accumulation of steam caused a greater pressure than the boiler could bear.

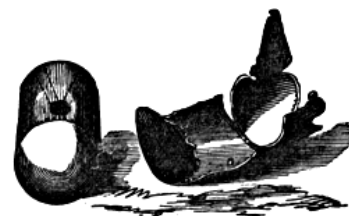

Fig. 17.

No.31. Newcastle.

June 7th.

none injured.

Marine Boiler in a Tug Boat.

The boiler was blown completely out of the vessel, and the greater part of it fell into the water, and a large piece alighted on a crowded quay, but without doing any damage.

The cause of the explosion was supposed to be over-pressure during a temporary stoppage of the engine.

No.32. Barnard Castle. (Fig. 18.)

June 11th.

2 injured.

Agricultural, of about 7 horse power. The barrel of the boiler was 6ft. 1in. long, 2ft. 5in. diameter; the fire-box end was 3ft. wide, and 2ft. 4in. deep; the fire-box was 2ft. 5½in. wide, and 2ft. 7in. high, and 1ft. 9½in. deep, with 23 tubes passing from it through the barrel to the smoke box and chimney. The boiler was fitted with a 2in. safety valve, which was intended to blow at 45 lbs., but as there was no ferrule, it is supposed to have been screwed down to a much greater pressure.

The upper portion of the shell over the fire-box rent through the manhole, and allowed the shell to open out and fall on each side. A large portion of the front plate was also torn off.

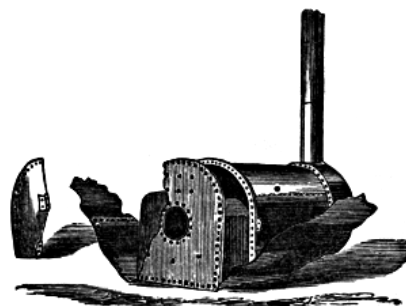

Fig. 18.

The cause of the explosion was the weakness of the manhole, which was not strengthened by any ring, and also excessive pressure from want of proper safety valve.

No.33. Breage.

June 11th.

1 killed.

Cornish Boiler, 36ft. 6in. long, and 6ft. diameter, 3/8 inch plates, 45 lbs.

The tube collapsed and rent, and the issuing contents caused the death of the attendant.

The weak tube of such large diameter, was unable to bear the ordinary working pressure, having no strengthening rings.

No.34. Nottingham.

June 19th.

2 killed, 4 injured.

Locomotive, ½ inch plates, 140 lbs.

The explosion occurred at the left hand side of the ring of plates in the barrel next the fire-box, and below the foot-plate. The rent tore along the edge of the lap and into the next ring of plates. The reaction of the issuing contents threw the engine off the rails.

The cause of the explosion was partial corrosion at the point of rupture and strain of the plates, as the boiler itself formed part of the frame of the engine.

No.35. Richmond.

June 26th.

2 injured.

Locomotive, being tried for the first time. The funnel came in contact with a bridge, and the dome was also torn off.

No.36. Gainsbro'. June 29th. none injured.

No details have been obtained.

No.37. Durham. July 2nd. 4 killed.

Plain Cylindrical Boiler, 30ft. long, and 6ft. diameter, 3/8 inch plates, 28 lbs. It had been repaired a short time before the explosion, with 5 new plates.

The boiler was torn up into several pieces, but the main portion remained flattened out on the seating, while some smaller pieces were sent 250 yards away.

The cause of the explosion was the deterioration of the boiler, and its frequent repair over the fireplace.

No.38. Liverpool. June 12th. 4 injured.

Elephant Boiler, 20ft. long, and 4ft. diameter, 3/8 inch plates, and worked at low pressure. The bottom shell had a tube through its whole length.

A rent took place in the lower part of the fireplace, and extended along the bottom, and the reaction of the issuing contents caused the top to rear up.

The cause of the explosion was supposed to be that the bottom plates were worn too thin to bear the ordinary pressure.

No.39. Sheffield. July 4th. none injured.

Two Tube Cornish Boiler, externally fired, 30ft. long, and 6ft. diameter, 3/8 inch plates, 40 lbs.

The second seam over the fire gave way, and the plate sank down upon the fire.

The cause of the explosion was the deterioration of the seams over the fire, in consequence of the deposit of scurf which could not be properly cleared off owing to the internal tubes.

No.40. Oldham. July 14th. none injured.

Boiler, with two internal furnaces, 9ft. 6in. long, and 2ft. 11in. diameter, 3/8 inch plates, uniting into one tube beyond. The furnace crown collapsed near the front of the boiler.

There was an extra weight upon the safety valve, and the steam valve was left closed, so that more pressure accumulated than the boiler could bear.

No.41. Oxford. July 23rd. 3 injured.

Rag Boiler, not used for the generation of steam. It was a plain cylinder, with hemispherical ends, about 16ft. long, and 7ft. diameter. There was a neck at each end upon which the boiler revolved, and through one of these the steam was admitted to a pressure of 30 lbs., in order to assist in cleaning the rags. There was a large manhole for filling and emptying.

The boiler rent in the middle, and each half was blown to some distance.

The manhole was so large, that the strength of the boiler was too much reduced, and the constant strain of revolving caused a central seam to give way at the ordinary pressure.

The sketch to [No.63](#) is of a similar boiler.

No.42. Tunstall. (Fig. 19.) July 28th. 2 killed, 7 injured.

Boiler, 36ft. 6in. long, and 8ft. 9in. diameter, 7/16 inch plates, with flat back and hemispherical front end, 36 lbs. A tube 3ft. 3in. diameter, passed from the back end nearly to the front, and returned to the back end, but of 6 inches less diameter and then passed to an iron chimney. The fire grate was beneath the hemispherical end.

The angle iron of the flat back end gave way, and separated from the shell and with the tubes attached was blown to a good distance, and the reaction drove the shell far in the opposite direction.

The cause of the explosion was the bad construction of the boiler, as the back end was quite unsupported, as there were no stays, and the bend of the tubes was not attached to the shell.

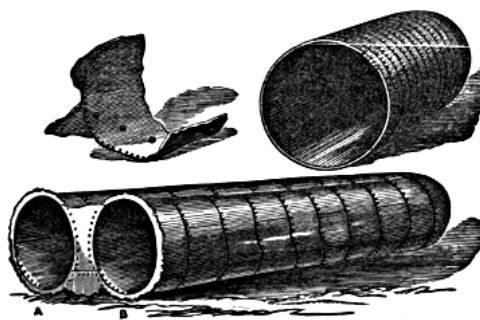

Fig. 19.

An adjoining boiler which was being cleaned inside by two men, was rolled off its seat by the force of the explosion.

No.43. Widnes.

August 2nd.

2 killed, 6 injured.

Plain Cylindrical Boiler, with flat ends, 23ft. long, 5ft. 3in. diameter, 3/8 inch plates, 40 lbs.

Both the flat ends were blown out, and the first ring of plates at the front end torn off.

The cause of the explosion was the weakness of the flat ends without stays.

No.44. Sunderland.

August 7th.

1 killed, 3 injured.

Locomotive, 13ft. 4in. long, 3ft. 11in. diameter, with 140 2-in. tubes. The fire-box was 4ft. 5in. long, 3ft. 6in. broad, and 5ft. deep, and made of copper, 1/2 inch thick, 100 lbs. It was fitted with two 4-in. safety valves, and a steam gauge.

The fire-box gave way about the middle of the left side, 2ft. 6in. below the water line, where corroded to 1/8 inch, and the issuing water and steam scalded those near.

No.45. Runcorn. (Fig. 20.)

August 22nd.

3 killed, 5 injured.

Marine Multitubular, 5ft. 8in. long, and 6ft. 6in. diameter, with two internal tubular furnaces, which joined to an internal chamber of large size, and small tubes passed to a smoke box and chimney in the front over the fire doors. Both ends were flat.

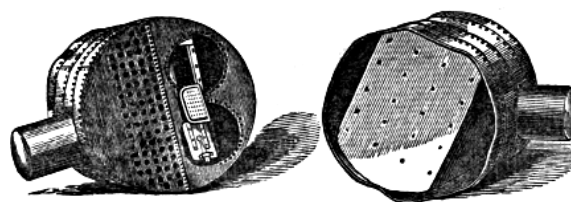

Fig. 20.

The flat back end was insufficiently stayed, and was blown completely out and torn into two pieces, the lower portion remaining in the vessel, and the upper part falling in the water, and the reaction of the issuing contents caused the boiler to be thrown on to the side of the quay.

No.46. Hull. (Fig. 21.)

August 25th.

1 injured.

One Tube Cornish, 24ft. 3in. long, and 6ft. diameter, taper tube 3ft. 5in. diameter, for about 7ft. 6in. in length, and 2ft. 6in. diameter for the rest of the length, 33 lbs.

The tube was much corroded, and the fireplace gave way on left side, and was so much torn, that the plates were forced out of the front.

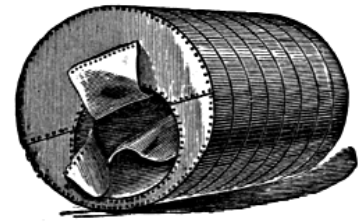

Fig. 21.

No.47. Morecombe.

August 27th.

3 killed, 1 injured.

Marine, of the usual construction, and had been tested to 60 lbs.

It gave way at the lower portion of the back, and the issuing steam and water scalded those near.

A seam rent, 6ft. 6in. long, had not been detected by testing.

No.48. Tuddenham.

August 29th.

2 killed, 2 injured.

Agricultural. It burst during a temporary stoppage from accumulation of steam, causing undue pressure.

No.49. Glasgow.

August 31st.

3 killed, 6 injured.

Upright Boiler, 36ft. high, 5ft. 6in. diameter, 7/16 inch plates, 45 lbs.

The bottom gave way from shortness of water, and the main bulk of the boiler was thrown straight up into the air to a great height, but descended again on its seating.

No.50. Chatham. (Fig. 22.)

September 7th.

2 killed, 30 injured.

Two Tube Cornish, 22ft. long, 7ft. 6in. diameter, with tubes, 3ft. diameter, 7/16 inch plate, 60 lbs.

Some rents took place at the under side of the shell, allowing the central portion to open out and blow away. The portion containing the dome was thrown to the left, and the other to the right. The front end, with 3 rings of the shell, with the tubes and back end, were but little moved from their original

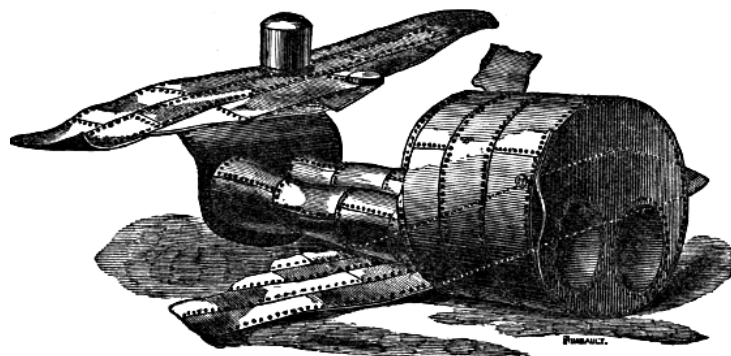

Fig. 22.

The tubes were dented in on the top and bottom, by the fall of some large coping stones upon them, but the crowns of the furnaces were uninjured, and there was no sign of shortness of water or overheating.

Extensive corrosion on the under side of the shell, where it rested on the brickwork, had so reduced the strength, that it was unable to bear the working pressure.

In the sketch the fragments are drawn so as to show their position when in the boiler.

No.51. Newark.

September 21st.

none injured.

One tube Cornish. The tube collapsed from shortness of water, and the escape of the steam and water blew off the door frame.

No.52. Ashton.

September 23rd.

1 injured.

Plain Cylindrical Boiler, 7ft. long, and 2ft. diameter, 3/8 inch plates, 30 lbs.

The upper part of the boiler at the first ring of plates was torn off, and the front end was blown out.

Extensive external corrosion, where the plates rested against the brickwork, rendered the boiler too weak to bear the ordinary pressure.

No.53. Norwich. ([Fig. 23.](#))

September 25th.

7 killed.

One Tube Cornish, 20ft. long, 4ft. 6in. diameter, tube 2ft. 6in. diameter, 3/8 inch plates, 100 lbs. It was double-riveted, and the crown of tube was strengthened with angle iron. The shell was formed of six rings, each of two plates alternately jointed top and sides. The third ring from the front had stripped off, and was thrown to the right and forwards against a wall. The line of rent was confined to the plates forming the ring, which was an outer one, and covered the two adjoining rings in the laps, the rent being from the edge of the inner lap to the nearest rivets. The first rent had taken place in the solid iron, about 1 inch from the rivets of a seam on one side, and from this the rent had extended along the seams on either side, and of course the whole ring soon tore off when the equilibrium was destroyed by the first rent.

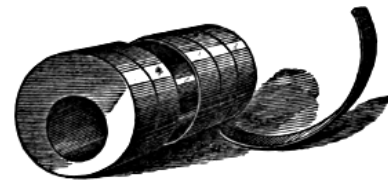

Fig. 23.

The fittings of the boiler were sufficient, except that there was only one safety valve, and that was so constructed that it could only open a very little way.

The cause was a defect in the iron at the point of the first rent, and accumulated pressure during the time of standing.

The cause was a defect in the iron at the point of the first rent, and accumulated pressure during the time of standing.

No.54. Macclesfield.

September 25th.

none injured.

Multitubular Boiler, with large internal fireplace, 60 lbs.

The furnace crown became overheated from shortness of water, and was crushed down and torn across two seams. The boiler was lifted from its seat and thrown back against a stone wall.

No.55. Chelmsford.

October 5th.

1 killed, 7 injured.

Agricultural, 45 lbs., and had only just been set to work.

The crown plate to the fire-box was so deeply corroded from long wear that it gave way, and the issuing contents scalded those near.

No.56. Greenwich. ([Fig. 24.](#))

October 8th.

2 killed, 2 injured.

Marine, 16ft. long, slightly oval, front end flat, 8ft. 6in. wide, 7ft. 10in. high, and the dimensions of the back hemispherical end were 2ft. less each way, 3/8 inch plates, 26 lbs. There were two internal fireplaces, of irregular shape, uniting at the back into one flue of similar shape, which did not come to the front, but passed through the steam space, and out at the top of the boiler.

While the vessel was waiting to start, with steam up, the wing furnace of the starboard boiler collapsed on the wing side, as shown by the dotted lines, and allowed the steam and water to escape

into the stoke hole.

The side of the furnace next the shell was rent along the edge of a longitudinal seam in a line, which was slightly nicked in the caulking. This rent extended about 5ft. 6in. from the front, and then at a cross seam it went along the line of rivets from the crown to the bottom of the furnace. Beyond this cross seam the furnace was collapsed, until it nearly touched the other side of the furnace, and the bulge died away towards the back end. There was also a rent in the lower part of the front of the shell, as shown in dotted line.

The cause of the explosion was the weakness of the shape of the flue, which was not stayed to the shell. It had evidently gradually been giving way some time before the explosion, and eventually collapsed at nearly the ordinary pressure. Symptoms of the same alteration of shape were noticed in the corresponding flue of the other boiler.

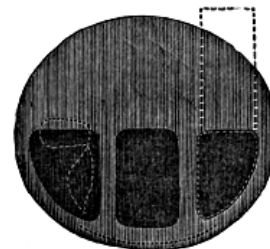

Fig. 24.

No.57. Liverpool. (Fig. 25.)

October 9th.

7 killed, 1 injured.

Crane Boiler, 5ft. 6in. high, and 2ft. 6in. diameter, with internal conical fire-box, with two cross tubes and a chimney at the top, $\frac{1}{4}$ inch plates, 75 lbs.

The outer shell of the boiler was rent into many pieces, leaving the central conical fireplace intact. The nature of the rents showed that the plate round the manhole, which was unstrengthened by a ring, had first given way, and all the other fractures had led away from that point. This is confirmed by the fact, that the manlid was thrown a good distance, with force enough to make its way through the timber walls of a cabin. The front plate divided into many pieces, and scattered right and left, while the back plate was thrown through a cabin in the opposite direction to the manhole.



Fig. 25.

The central flue showed a slight indication of overheating, but the construction was such that the upper portion passed through the steam space, and was always exposed to the action of the fire, without the protection of the contact of water. The manhole without a ring on its edge to strengthen the plate, and held in by two clamps, which caused additional strain when carelessly screwed up, was by far the weakest place. The engine was standing after a short time of working, and as the safety valve was very defective, and could be screwed down until tight, against almost any pressure, it is most probable that the pressure mounted much higher than usual, when the weakest part gave way, and led to the sudden tearing up and scattering of the whole fabric.

Faulty construction of both boiler and fittings, rendered it unable to bear that accumulated pressure, which the safety valve ought to have made impossible.

No.58. Durham.

October 13th.

1 killed.

One Tube Cornish, 14ft. long, 6ft. diameter, internal flue 3ft. 3in., by 2ft. 10in., $\frac{3}{8}$ inch plates, 27 lbs., standing on three saddles, with a bearing surface of 3ft. by 4 inches.

A portion of plate 20in. by 18in., at the bottom of the boiler, was so corroded that it was blown out, and the issuing contents scalded a man to death.

No.59. Bristol. (Fig. 26.)

November 1st.

7 killed.

Two Marine Boilers exploded simultaneously. They were 16ft. long, 6ft. 6in. diameter at the flat front ends, and somewhat less at the hemispherical back ends. Each had two internal fireplaces, united in one flue, which returned nearly to the front and passed up through the steam space, and out at the top of shell into the funnel. The central fireplaces were not circular, and the outside fireplaces and the return flues were still more distorted, but the weakness of the shape was somewhat compensated for by stays between the tubes, and from the tubes to the shell. The mountings to the boiler were of the ordinary kind and efficient.

The under sides of the shells were so deeply corroded that they were rent longitudinally for their

whole length, allowing the sides to open out and tear away from the front ends. Each shell fell at a considerable distance. The furnaces, with parts of the front ends attached, fell into the water, but except one of the side flues that was a little collapsed, they were uninjured. Small pieces of the front ends were thrown to a great distance. The sides of the vessel were so completely blown out that she sank.

The corrosion was no doubt caused by the leakage of the vessel, keeping the shells of the boilers constantly wet.

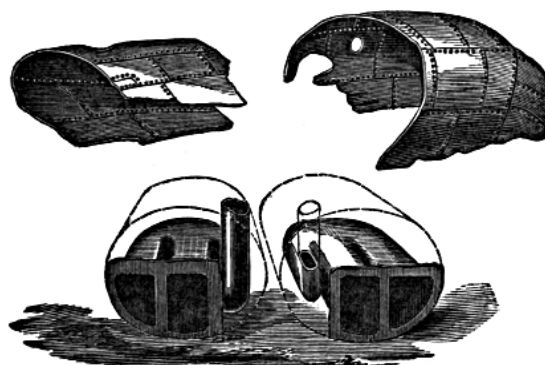

Fig. 26.

No.60. London. (Fig. 27.)

November 3rd.

none injured.

Agricultural, barrel was 3ft. 9in. long, and 2ft. 6in. diameter, 70 lbs. From the internal fire-box the heat passed through a number of 1-inch tubes to the front smoke box and chimney.

During a stoppage for breakfast, the fire-box end was torn from the barrel, and from the position of those fragments that could be found, the boiler appeared to have turned over. Part of the fire-box was sent through the stage upon which the boiler was travelling, and the barrel with the tubes remaining in it, first struck a rail which caused it to be dented in, and then rebounded to a point about 100 yards from its original position.

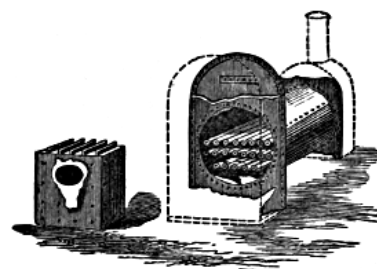

Fig. 27.

Enough of the fragments were not recovered from the river to trace the cause of the explosion, but it is presumed that, although when the boiler was left, only 20 lbs. pressure was shown by the gauge; the fire door being left closed, the pressure must have risen to a point much above the working pressure, and to more than the boiler could bear.

No.61. Bilston. (Fig. 28.)

October 1st.

none injured.

One Tube Cornish, 22ft. long, 6ft. diameter, tube 4ft. 6in. diameter, 3/8 inch plates, 12 lbs. There was an unusually large dome at the back end, 5ft. diameter, and the whole of the shell was cut out from under it, so that the construction was peculiarly weak.

The boiler had been off for cleaning, and steam was being got up in the night, and it was said that an extra pressure was caused by the stop valve being left closed, but it could not have been very great, or the large tube would have collapsed.

The dome was split in two, in the line marked in the sketch, owing to the extreme weakness of the shell at the juncture of the dome, and the shell was a little ruptured on each side of it, and so large a rent was suddenly made, that the contents of the boiler passed harmlessly into the air, without moving the boiler on its seat.

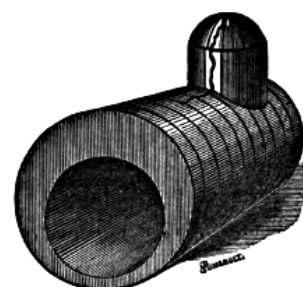

Fig. 28.

No.62. Preston. (Fig. 29.)

November 11th.

1 killed, 1 injured.

One Tube Cornish, 16ft. 3in. long, and 5ft. 8in. diameter, tube 3ft. 1in. diameter, 7/16 inch plates, 60 lbs.

The tube collapsed from end to end, from over-pressure, as the man in charge had fastened 3 bricks to the lever of the safety valve causing 27 lbs. extra pressure, under the impression that he could thus accumulate a quantity of steam during the night, to be available on commencing work on the morrow.



FRONT VIEW Fig. 29.

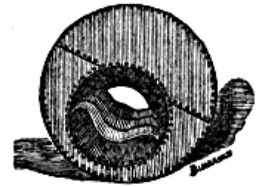

BACK VIEW Fig. 29.

No.63. Tamworth. ([Fig. 30.](#))

November 20th.

none injured.

Revolving Steam Chamber, 12ft. 6in. long, and 5ft. diameter, 12 lbs.

The manhole was large, to facilitate filling and emptying, and was rectangular and unstrengthened on the edges, and measured 3ft. 6in. in length, and 1ft. 6in. in width, and the lid fitted on the inside and was held by clamps.

The boiler was much out of repair, and a crack shown in sketch, from one corner of the manhole to the commencement of the hemispherical end was only temporarily prevented from leaking by a screw-patch, which did not restore the strength.

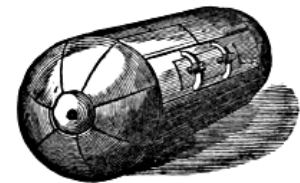

Fig. 30.

The explosion happened when in revolving, the manlid was downwards, and the lid was driven nearly through the floor, and the shell was rent from opposite corners of the manhole, and blown through the roof.

The large manhole cut away nearly all the strength on one side, and the fastenings of the lid were not contrived to compensate at all for the loss of strength. The constant strain when revolving, also tended to weaken it. These two causes together were sufficient to account for the explosion, at the usual working pressure of 12 lbs., although it is possible that it might have been increased to 35 lbs., as that was the pressure in the boiler supplying the steam, although the pressure was regulated by a check valve.

This explosion (and also [No. 41](#) in this year) clearly show that a mere vessel of steam not exposed to the fire, or any chance of overheating of the plates, can burst and cause very great destruction, although there could be no sudden *increase of pressure* which is so often supposed necessary to account for the havoc caused by explosions.

No.64. Manchester.

November 26th.

none injured.

This Boiler was 28ft. long, 7ft. diameter, made of 7/16 inch plates, and worked at 50 lbs. pressure, with two internal fireplaces united into one tube beyond.

The sides of the oval chamber forming the junction of furnaces and tube, crushed inwards, being of such a weak shape as to be unable to resist the ordinary working pressure.

No.65. Hull. ([Fig. 31.](#))

December 1st.

3 killed, 2 injured.

Agricultural, 7ft. 6in. long, and 3ft. 8in. diameter, ¼ inch plates, 35 lbs., fire-box 2ft. long, and 2ft. 10in. broad. Two 11½-inch tubes led to an internal chamber at the other end of the boiler, and three

8¼-inch tubes led back again to an external smoke box and chimney fixed over the fire door.

The bottom of the right hand side lower tube was forced upwards, and rent along to within 12 inches of the fire-box.

The tubes were so corroded from leakage of patches, that they were unable to bear the slight increase of pressure during a short stoppage.

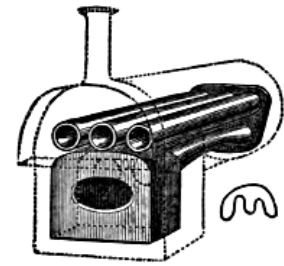

Fig. 31.

No.66. Glasgow.

December 4th.

2 killed, 6 injured.

Two Tube Cornish, 22ft. long, and 7ft. 6in. diameter, tubes 3ft. diameter, and strengthened with rings in the approved manner.

The second from the back of the seven rings, was ruptured at the bottom and torn off by a rent through the line of rivets on each side, and the boiler was thrown from its seat, and turned completely over, so as to lie in a contrary direction to what it was before.

Extensive corrosion, from leaking of the seams beneath the brickwork, where hidden from view, was the cause of explosion.

No.67. Willenhall.

December 7th.

none injured.

Plain Cylinder, with hemispherical ends, 9ft. long, 3ft. 3in. diameter, 20 lbs.

The boiler was rent all along one side, and the reaction of the issuing contents caused it to be thrown some yards away, and one of the ends became altogether detached, and flew to a considerable distance.

The plates were so thinned by corrosion, that they gave way on a very slight increase of pressure during a temporary stoppage of the engine.

No.68. Glasgow.

December 12th.

1 killed, 1 injured.

This Boiler was 14ft. long, with hemispherical ends, and 7ft. diameter, 30 lbs.

The cause of the explosion was over-pressure and thinness of plates, wasted by corrosion.

No.69. Manchester. (Fig. 32.)

December 15th.

5 injured.

Two Tube Cornish, 24ft. long, 6ft. 6in. diameter, tubes 2ft. 8in. diameter, 7/16 inch plates, 50 lbs. The boiler was fired in each of the tubes in the ordinary way, and also the heat from two furnaces passed from the back, one on each side of the outside shell.

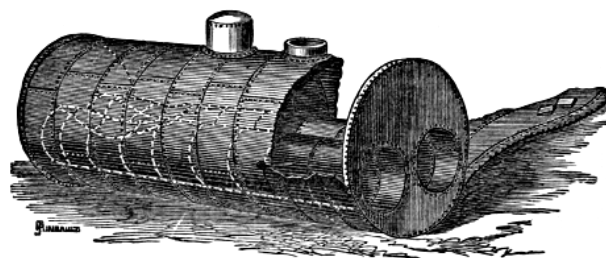

Fig. 32.

Both the internal furnaces collapsed, until the crowns almost touched the fire bars, as shown in dotted lines, but without fracture. The back of the shell, on the right side, had evidently been overheated, and had rent along the centre of a bulge, and this rent had extended along the line of rivets of the transverse seam on each side, allowing two rings of the plates of the shell to open out flat as shown. There was a bulge on the plate, on the right side of shell, corresponding with the one which parted on the opposite side.

The cause of the explosion was overheating of the plates from shortness of water.

No. 70. Aberdeen.

December 24th.

1 injured.

No particulars have been obtained.

BOILER EXPLOSIONS IN 1867.

No.1. Hull.

January 2nd.

1 killed, 1 injured.

A small Boiler to heat a bath. It exploded, causing great damage, because the connecting pipes were frozen. All such boilers should have a proper safety valve.

No.2. Durham. ([Fig. 1.](#))

January 2nd.

3 killed, 3 injured.

Plain Cylinder, 33ft. long, 6ft. diameter, 33 lbs. pressure. Only set two days, but was old and deteriorated, and had worked before at another place. It had been turned $\frac{1}{4}$ round, and old fitting-holes stopped. First rent was supposed to be in a seam at front end, over the fire. Main portion of shell was driven back, and front end forward, and torn in its flight. The cause of explosion was, that the seam in front was overheated and injured, and also incautious working without a steam gauge.

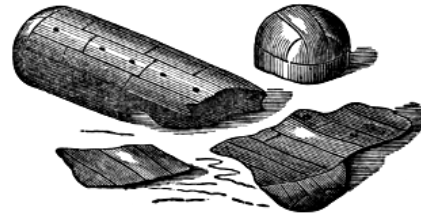

Fig. 1.

No.3. Sheffield. ([Fig. 2.](#))

January 2nd.

1 killed, 4 injured.

One Tube externally fired, 30ft. long, 6ft. 6in. diameter, with dished ends. Tube 2ft. 9in. diameter, slightly oval. Pressure 60 lbs. Tube collapsed sideways from end to end, because it was not strengthened by hoops or other means, which were the more needed, because it was slightly oval, and the longitudinal seams were nearly in one line.

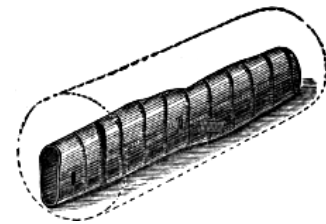

Fig. 2.

No.4. Preston.

January 3rd.

1 killed.

Boiler for heating apparatus. Fire was lighted without noticing that as there was no safety valve, and that all escape of steam was prevented by the connecting pipes being frozen.

No.5. Westerham.

January 5th.

1 killed.

Cast-iron Boiler for heating water for a horse shower bath, fixed behind an ordinary fireplace. Burst and caused great damage, owing to the pipes being frozen. There was no safety valve.

No.6. Barr.

January 9th.

1 killed, 3 injured.

Kitchen Boiler, which burst because the supply pipes were stopped by frost, and there was no safety valve.

No.7. London.

January 11th.

1 killed.

Cornish, 12ft. long, 4ft. 6in. diameter, tube 2ft. 4in. diameter, pressure 40 lbs. Small piece of plate was blown out near the bottom, and the boiler was displaced by the reaction of issuing contents. The cause of explosion was extensive external corrosion on the lower part.

No.8. Preston.

January 16th.

none injured.

Kitchen Boiler. Burst and did great damage, because pipes were frozen preventing escape of steam. There was no safety valve.

No.9. Brechin.

January 23rd.

1 killed.

Kitchen Boiler. Fire had been out some days, and the boiler burst soon after re-kindling it and did much damage, because the supply pipes were stopped by frost, and there was no safety valve for escape of steam.

No.10. Sunderland. (Fig. 3.)

January 26th.

3 injured.

Plain Cylinder, 30ft. long, 6ft. 2in. diameter. Pressure 30 to 35 lbs. Rent into four pieces, which were flattened out and scattered on to other boilers, but are arranged in sketch so as to show their original position in the boiler. It had worked a very long time, and was overheated and injured along the fractured line.

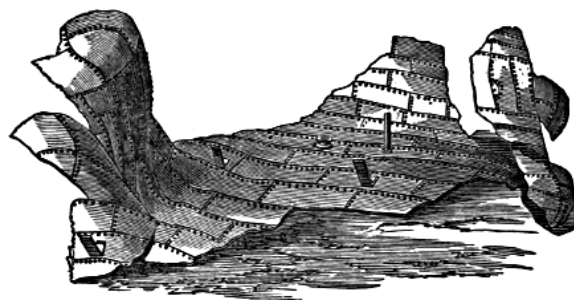

Fig. 3.

No.11. Exeter. (Fig. 4.)

January 30th.

2 killed, 2 injured.

Elephant Boiler, 16ft. long, 5ft. diameter, tubes 1ft. 10in. diameter, 45 lbs. pressure. Flat end blew out, throwing boiler upwards by reaction, but shell and tubes were not injured. The flat end was not sufficiently stayed, having only one stay-rod to the centre, the bolt of which was broken.

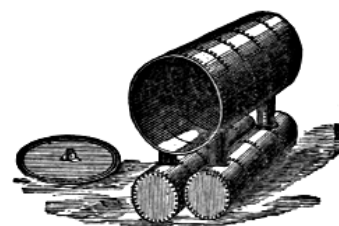

Fig. 4.

No.12. Glasgow.

February 8th.

1 killed, 4 injured.

Small Boiler to 6-horse power engine. Gave way at centre of furnace, and water forced out at both ends, and it was suspected that the water was low.

No.13. Sheffield. (Fig. 5.)

February 11th.

4 injured.

Cornish, about 30ft. long. Tubes 3ft. unstayed. Tube collapsed sideways, and was rent from grate bars to end, without injuring front plates or shell. It was said to be short of water, but most likely the true cause was the weakness of the tube.



Fig. 5.

No.14. Manchester.

February 15th.

none injured.

Two flued, 28ft. long, 6ft. 9in. diameter, slightly oval; plates 3/8 inch; tube 2ft. 8in. diameter, pressure 45 lbs. Shell had once been externally fired. Rent along the seams which were in one line, and a large piece of the plate blew away, leaving tubes uninjured. The cause of explosion was defective form and worn out state of shell.

Agricultural, 45 lbs. pressure. Fire-box blew off, and the outer shell separated from it. The cause of explosion was over-pressure from the safety valve being screwed down.



Fig. 6.

No.16. Lynn. ([Fig. 7.](#))

March 19th.

8 killed, 4 injured.

Agricultural, 45 lbs. pressure. Fire-box and tubes blew out. The cause of explosion was over-pressure, as the safety valve was tied down with string.

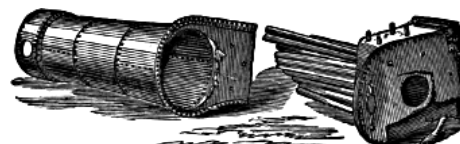

Fig. 7.

No.17. Blackbraes.

March 23rd.

3 killed, 1 injured.

Colliery Boiler, 30 lbs. pressure. Rent in two while the engine was standing, but no details obtained.

No.18. Barnsley. ([Fig. 8.](#))

March 29th.

2 killed, 2 injured.

Small plain Cylinder, with ends nearly flat, 4ft. 7in. long, 2ft. 4in. diameter, plates $\frac{3}{16}$ inch. No emptying plug or feed-pipe, and only a very small hand-hole. Front end attached by slight angle iron, which gave way, leaving the shell unmoved. The cause of explosion was the internal corrosion of front end owing to very bad water being used. The plates were reduced to a knife edge in line of fracture.

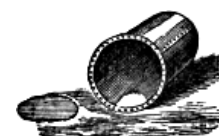

Fig. 8.

No.19. Cornwall. ([Fig. 9.](#))

April 10th.

1 killed, 1 injured.

Cornish, one tube 32ft. long, 6ft. diameter, tube 3ft. 10in. diameter, plates $\frac{3}{8}$ inch, pressure 25 to 40 lbs. It was 20 years old, but just repaired and reset. Furnace tube failed and collapsed from one end to the other, except about 4 feet of front, owing to its weakness, being unstrengthened by hoops or cross tubes.

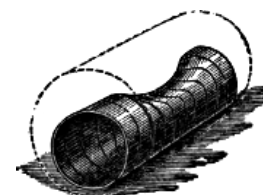

Fig. 9.

No.20. Belfast. ([Fig. 10.](#))

April 20th.

1 killed, 2 injured.

Plain Cylinder, 6ft. long, 2ft. 5in. diameter, plates $\frac{1}{4}$ inch, pressure 90 lbs. The end blew out from excessive pressure, as the escape from the safety valve was prevented by a plug in the exit pipe.



Fig. 10.

No.21. Birmingham. ([Fig. 11.](#))

May 9th.

2 injured.

Plain Cylinder, 3ft. 2in. long, 1ft. 8in. diameter, plates 5/16 inch, pressure 30 lbs. Workmanship and material very inferior. Piece of top ripped out from manhole and allowed manlid to blow out through manhole. The cause of the explosion was, the large manhole and over-pressure. The safety valve was too small, and very roughly made.



Fig. 11.

No.22. Hartlepool. ([Fig. 12.](#))

May 10th.

1 killed, 1 injured.

Locomotive, 130 lbs. pressure. Barrel blown away and broken to pieces, leaving fire and smoke boxes. The cause of explosion was supposed to be the strain on the boiler caused by its being made a stay to the frame without allowance for expansion, and thereby weakening a horizontal seam.

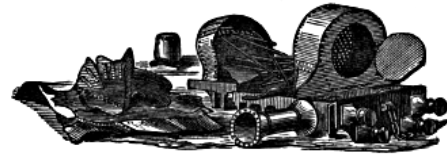

Fig. 12.

No.23. Newark. ([Fig. 13.](#))

May 18th.

4 injured.

Cornish, one tube 20ft. 6in. long, 5ft. 4½in. diameter, tube 3ft. diameter, plates 3/8 inch, pressure 64 lbs. The ends came out and tube collapsed for its full length, every joint being broken. The cause of explosion was bad construction and workmanship, and tube too weak for pressure.

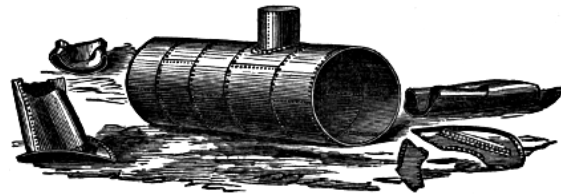

Fig. 13.

No.24. Tamworth. ([Fig. 14.](#))

June 4th.

2 killed.

Two tube, externally fired, 30ft. long, 7ft. diameter, tubes 2ft. 4in. diameter, pressure 50 lbs. Two plates lately put in bottom gave way, and shell rent along bottom and opened out, dividing into several pieces, which were scattered to great distances, but are arranged in sketch so as to show their original position. The cause of explosion was too frequent repair over the fireplace, and external firing.

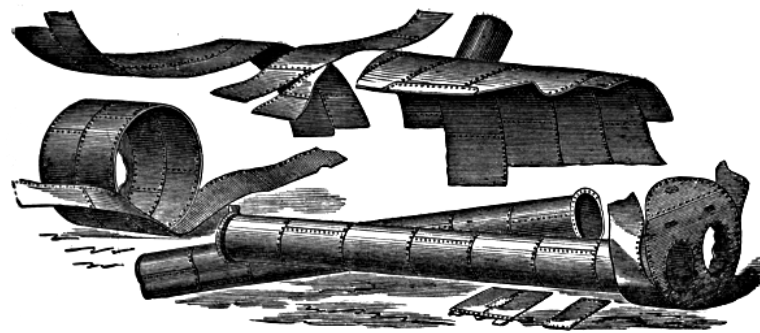

Fig. 14.

No.25. Dudley. ([Fig. 15.](#))

July 10th.

1 killed, 2 injured.

Balloon, 22ft. diameter, pressure 5 lbs. Bottom blew out and was torn in pieces. Main portion of shell fell over on to another boiler. The cause of explosion was deep corrosion along the bottom where it rested on the brickwork.

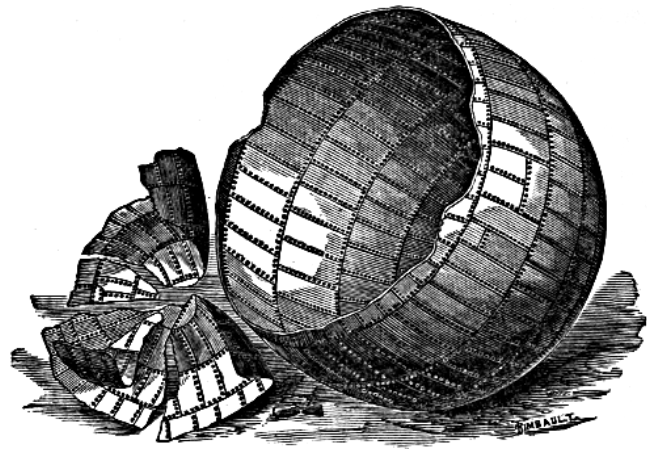

Fig. 15.

No.26. Batley. ([Fig. 16.](#))

July 11th.

3 killed, 3 injured.

One tube Cornish, 26ft. long, 8ft. 10½in. diameter, tube 5ft. diameter, for 8ft. 6in. of front end, tapering to 4ft. diameter at back, pressure 30 lbs. Rent along bottom, allowing central ring of plates to open out. The whole boiler was thrown some distance by the reaction of issuing contents. The cause of explosion was corrosion at mid-feather wall, the plates being little thicker than paper.

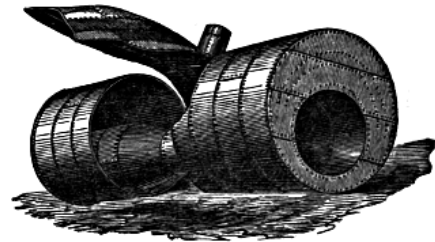

Fig. 16.

No.27. Rotherham. ([Fig. 17.](#))

July 13th.

none injured.

Two tube Cornish, 31ft. long, 7ft. diameter, tube 2ft. 7in., tapering to 2ft., pressure 55 lbs. Left hand tube collapsed, and about the centre of collapse, plate was torn in two pieces from seam to seam. The cause of explosion was overheating, because the water was being let low before all the fire was out.

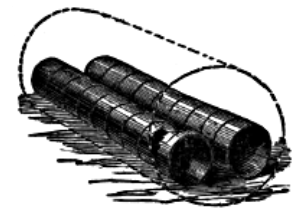

Fig. 17.

No.28. Bilton. ([Fig. 18.](#))

July 24th.

1 injured.

Locomotive. Side-plate in the upper part of high top fire-box blew away. The cause of explosion was most likely the boiler being made the frame of the engine without allowance for expansion.



Fig. 18.

No.29. Ecclesfield.

August 5th.

1 killed, 2 injured.

Full particulars were not obtained, but the steam and hot water were allowed to come in from a neighbouring boiler through the blow-off pipe while the men were cleaning.

No.30. Belfast. (Fig. 19.)

August 27th.

7 killed, 3 injured.

Cornish, 18ft. long, 4ft. 9in. diameter, tube 1ft. 6in. diameter, plates $\frac{3}{8}$ inch, pressure 50 lbs. There were no stays. End plate blew out while being caulked at a jump joint in back angle iron. The cause of explosion was bad construction and want of stays, and also want of proper care in working.

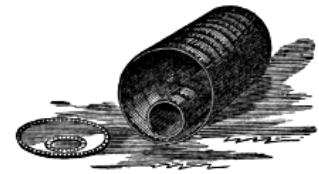

Fig. 19.

No.31. Plashetts.

September 2nd.

2 injured.

Locomotive, but no details obtained.

No.32. Ashton.

September 9th.

none injured.

Two flued, 40 lbs. pressure. The cast-iron mouth-piece of manhole fractured from insufficient strength, and allowed lid and upper flange to blow off.

No.33. Blackburn.

October 4th.

4 injured.

Water Heater, made of large bottle-shaped pipes placed in the flue. The force of explosion caused the neighbouring boilers to be unseated. No details have been obtained as to the cause of the explosion.

No.34. London. (Fig. 20.)

October 7th.

1 killed.

One tube Cornish, 11ft. long, 4ft. diameter, plates $\frac{3}{8}$ inch, tube 2ft. $1\frac{1}{2}$ in. diameter, pressure 50 lbs. Gave way underneath. Top thrown upwards. Front part and tube thrown to the front. The cause of the explosion was extensive corrosion at the bottom where it touched the walls.



Fig. 20.

No.35. Preston.

October 31st.

none injured.

Cornish, 26ft. long, 5ft. 6in. diameter, tube 2ft. 11in. diameter, plates $\frac{3}{8}$ inch. Pressure 30 lbs. Tube collapsed for want of proper strengthening hoops, blowing out back end, and throwing boiler forward.

Plain Cylinder, 19ft. long, 6ft. diameter, pressure 40 lbs. It was 36 years old, and iron deteriorated and also much patched. The cause of explosion was over-pressure for so old a boiler.



Fig. 21.

No.37. Bradford. ([Fig. 22.](#))

November 6th.

2 killed, 3 injured.

Agricultural, wagon-shaped, 6ft. 5in. long, 3ft. high, 2ft. 4in. wide, plates $\frac{3}{8}$ inch, pressure 50 lbs. Upper portion of barrel blew off. The cause of the explosion was over-pressure from locked safety valve and defective construction.

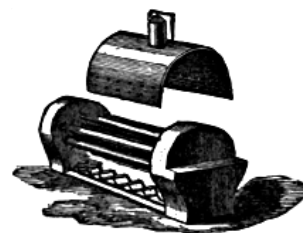

Fig. 22.

No.38. Sheffield. ([Fig. 23.](#))

November 7th.

1 injured.

Plain Cylinder, 12ft. 3in. long, 3ft. 11in. diameter, pressure 20 lbs., flat front, and round back end. Main portion thrown back and front forward. Front torn all round the root of angle iron, and stay rivets drawn through flat end. The cause of explosion was weakness of construction of flat end, and bad safety valve, which could have been loaded to 60 lbs.

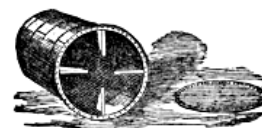

Fig. 23.

No.39. Langley Mill. ([Fig. 24.](#))

November 11th.

3 killed, 10 injured.

Plain Cylinder, 40ft. long, 5ft. diameter, plates $\frac{7}{16}$ inch, pressure 45 to 50 lbs. Parted at third seam, and front thrown forward and main portion backwards. The cause of explosion was a seam-rip of old standing near patch at place of first rupture.

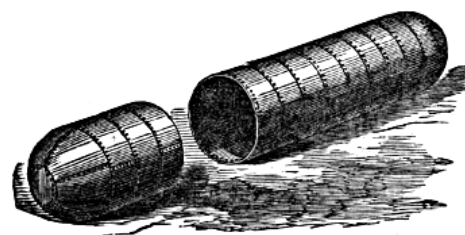

Fig. 24.

No.40. Bradford. ([Fig. 25.](#))

November 14th.

4 killed, 3 injured.

Breeches tube 25ft. 6in. long, 7ft. 6in. diameter, plates $\frac{7}{16}$ inch, pressure 30 lbs. Front end and fire-grate tubes and taper junction were thrown to the front in one piece. Main shell not injured. Back part of tube remained in boiler. Bottom part of taper junction where flattened to receive the two fire tubes, collapsed upwards. The cause of explosion was the want of proper stays or strengthening tubes, and consequent weakness. There was only one safety valve of small size.

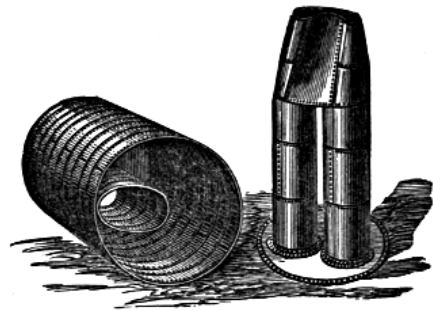

Fig. 25.

No.41. Chippenham. ([Fig. 26.](#))

November 21st.

3 killed, 2 injured.

One tube Cornish, 11ft. long, 5ft. diameter, pressure 44 lbs. Tube gave way at an old crack at back of strap-plate and partially collapsed.

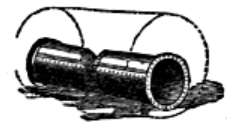

Fig. 26.

No.42. Dudley. ([Fig. 27.](#))

November 27th.

1 killed.

Plain Cylinder, 25ft. long, 6ft. diameter, plates $\frac{7}{16}$ inch, pressure 50 lbs. Had been a one tube Cornish, but tube had been taken out, leaving flat ends. Back end was blown out. Main shell thrown forwards. The cause of explosion was weakness of construction in not sufficiently strengthening the flat end to compensate for loss of tube.

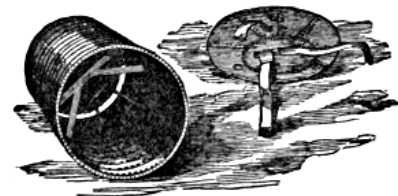

Fig. 27.

No.43. Shields. ([Fig. 28.](#))

December 7th.

none injured.

One tube Cornish, 28ft. long, 6ft. diameter, tube 4ft. diameter, plates $\frac{3}{8}$ inch. Pressure 28 lbs. Tube collapsed for the whole length, but no particulars of the cause obtained.



Fig. 28.

No.44. Belfast.

December 14th.

2 killed.

Some repair had been done to a Boiler, and a blank flange used to stop off the steam was being removed without shutting the stop-valves to the other boilers, and the joint blew out when the bolts were loosened.

One tube Cornish, 18ft. long, 6ft. diameter, tube 3ft. 2in. diameter, plates 3/8 inch. Pressure 25 lbs. Rent along bottom, and two rings of plates blown away, but tube and ends not much injured. The cause of explosion was extensive corrosion on the part resting on the mid-feather wall.

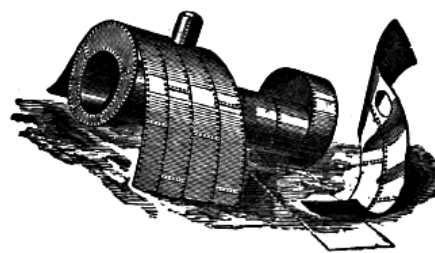

Fig. 29.

No.46. Barnsley. ([Fig. 30.](#))

December 28th.

1 killed.

Balloon, 11ft. 6in. diameter, and 11ft. 6in. high, plates 3/8 inch. Bottom domed up 3ft. 6in. over fire; ordinary pressure 8 lbs. Boiler had worked two days at 25 lbs. pressure, but safety valve loaded to 16 lbs. The cause of explosion was undue pressure for an old boiler of such weak shape.

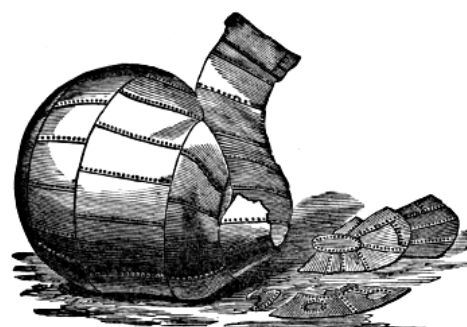

Fig. 30.

No.47. Leeds. ([Fig. 31.](#))

December 30th.

2 injured.

Two tube Cornish, 22ft. long, 7ft. 2in. diameter, tubes 2ft. 7in. diameter, pressure 15 lbs. Rent along bottom, and shell blown away, leaving tubes and ends nearly uninjured. The cause of explosion was, that the bottom was corroded to a knife edge all along the mid-feather wall.

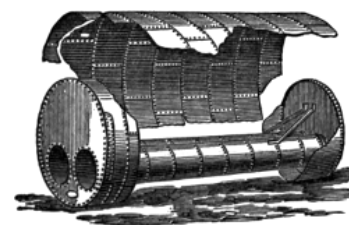

Fig. 31.

No.48. Shields. ([Fig. 32.](#))

December 31st.

2 killed, 1 injured.

Plain Cylinder, 30ft. long, 4ft. 6in. diameter, plates 3/8 inch, pressure 29 lbs. Rent over fire near where a new plate had lately been put in. Front part of shell opened out and rent, and back end blew away in one piece. The cause of explosion was deterioration from 20 years' wear, and bad management.

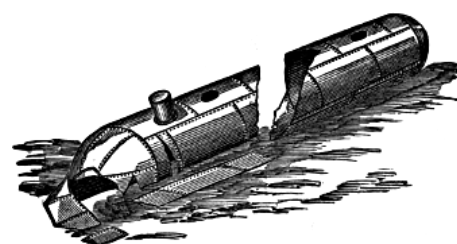

Fig. 32.

BOILER EXPLOSIONS IN 1868.

No.1. Newcastle. ([Fig. 1.](#))

January 13th.

none injured.

One of three. Plain Cylinder, 27ft. long, 5ft. diameter, $\frac{3}{8}$ inch plates, 35 lbs. pressure. The boiler was much torn up, and all the fragments thrown to the front of their original position. The cause of the explosion was that the boiler was very old and much deteriorated, so that it was unable to bear the ordinary pressure. The longitudinal arrangement of the plates, and the entrance of the feed directly on the bottom, no doubt contributed to the weakness.

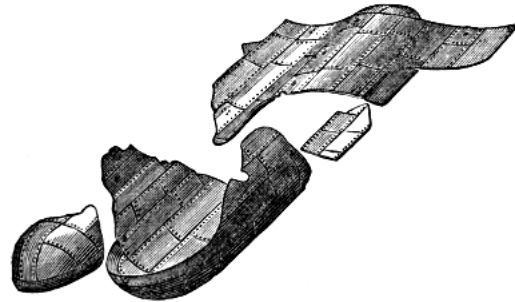

Fig. 1.

No.2. Glasgow.

January 27th.

1 killed, 5 injured.

One of four. Kier or steam chamber, and not used for generating steam. It was 8ft. 6in. high, 6ft. 6in. diameter, $\frac{7}{16}$ inch plates, 40 lbs. pressure. It was rent from top to bottom, owing to inferior iron and workmanship.

No.3. Sheffield. ([Fig. 2.](#))

January 28th.

1 killed.

One of four. One tube Cornish, 26ft. 4in. long, 6ft. 6in. diameter. Tube 3ft. 9in. diameter, $\frac{3}{8}$ inch plates, 15 lbs. pressure. The dotted line shows outside shell of boiler. The tube collapsed from end to end while the steam was being raised, owing to the weakness of so large a tube without strengthening rings.

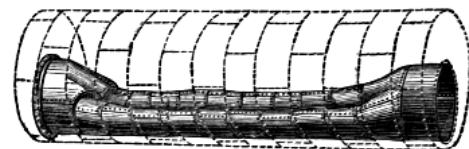

Fig. 2.

No.4. London. ([Fig. 3.](#))

January 29th.

1 killed.

One tube Cornish, 18ft. 3in. long, 4ft. 10in. diameter, $\frac{3}{8}$ inch plates. Tube 3ft. diameter, $\frac{5}{16}$ inch plates. In sketch the external shell is shown in outline to allow the tube to be seen. The tube collapsed owing to shortness of water, and rent open at one seam, allowing the contents to issue violently, although the boiler itself was not disturbed.

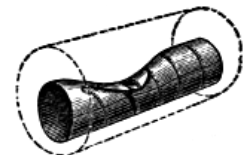

Fig. 3.

No.5. Bolton. ([Fig. 4.](#))

January 31st.

1 injured.

Locomotive, 90 lbs. Sketch shows interior view of fire-box with front removed. The left side of the copper fire-box burst inwards owing to the plate in line of fracture being corroded to less than $\frac{1}{8}$ inch.



Fig. 4.

No.6. Stoke. (Fig. 5.)

February 6th.

none injured.

One of three. One tube Cornish, with two external fire grates with a water tube over each fire. It was 30ft. 2in. long, 6ft. diameter. Tube 3ft. diameter, 3/8 inch plates, 40 lbs. pressure. External shell is shown in dotted lines to allow of the tubes being seen. The tube had formerly been placed rather higher in the boiler. The tube collapsed sideways, having become overheated from shortness of water. The boiler itself was but little disturbed.

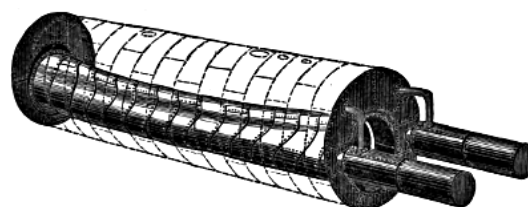

Fig. 5.

No.7. Kelso. (Fig. 6.)

February 11th.

none injured.

One tube Cornish, 9ft. 9in. long, 4ft. 6in. diameter. Tube 2ft. 3in. diameter, 5/16 inch plates, 30 lbs. pressure. The boiler rent open at the bottom, and was thrown a considerable distance by the reaction of the issuing contents. The plates along the bottom were reduced by corrosion to 1/16 inch where in contact with the brickwork, so that the boiler was unable to bear the usual working pressure.

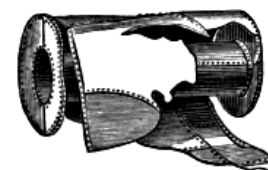

Fig. 6.

No.8. Durham. (Fig. 7.)

February 12th.

2 killed, 1 injured.

One of four. External shell is shown in dotted lines in sketch, to allow the tubes to be seen. It was 20ft. long, 7ft. diameter, 40 lbs. pressure. The two internal fire grates in the flues were 2ft. 8in. diameter, which joined at the back with a central return flue to a chimney passing out of the top of the boiler. The sides of flues were flattened to allow them to be packed closer together, and especially the central return flue, which was flattened on both sides, and thus rendered so weak that the left side collapsed and allowed the contents of the boiler to issue, blowing out the grate on the left side.

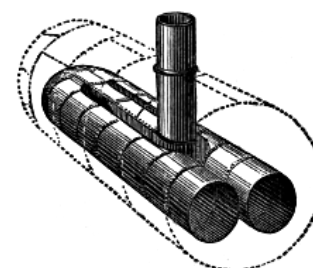

Fig. 7.

No.9. Halifax. (Fig. 8.)

March 3rd.

none injured.

Plain Cylinder, with flat ends, 18ft. 6in. long, 3ft. 11in. diameter, 3/8 inch plates, 50 lbs. pressure. The back end gave way at the root of the angle iron all round, and was thrown 60 yards to the rear. The boiler was forced forward, and tilted up by the reaction of the issuing contents, and forced through a wall. The cause of explosion was the want of sufficient stays to the flat end.

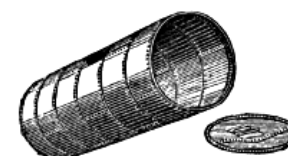

Fig. 8.

No.10. Newcastle. (Fig. 9.)

April 4th.

1 killed, 4 injured.

One of four. Plain Cylinder, 28ft. long, 6ft. diameter, 3/8 inch plates, 30 lbs. pressure. The boiler was much torn and scattered, and much damage was done. The plates were improperly arranged longitudinally. The boiler gave way at a patch lately put on, and had become so deteriorated by nearly 30 years' wear, that it was unable to bear the usual pressure.

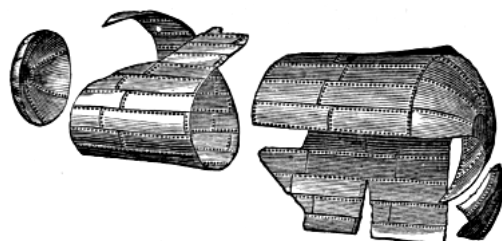

Fig. 9.

No.11. Aberdeen.

April 7th.

1 killed.

Two tube Cornish, 6ft. diameter. Few particulars have been obtained. The upper part of front end was blown out and did considerable damage. Most likely this was for want of proper stays.

No.12.

April 15th.

1 injured.

One of four. One tube Cornish, 15ft. long, 4ft. 7in. diameter. Tube 2ft. 8in. diameter, 1/4 inch plates, 60 lbs. pressure. The tube collapsed and rent open near the bridge, owing to its weakness with such thin plates and no strengthening rings.

No.13. Cornwall.

May 1st.

1 killed.

No details obtained. One tube Cornish. Tube collapsed, owing to its weakness without strengthening rings.

No.14. Cornwall.

May 9th.

none injured.

Few particulars obtained. One tube Cornish, 34ft. long. Tube 4ft. diameter, 3/8 inch plates, 40 lbs. pressure. Tube collapsed owing to its weakness without strengthening rings.

No.15. Oldham.

May 11th.

1 killed, 1 injured.

A very small plain cylinder, 3ft. 5in. long, 1ft. 8in. diameter, 1/4 inch plates, 45 lbs. pressure. It burst at a faulty place at the lower part of the back, on the left hand side, allowing the hot water to issue, but the boiler was not much disturbed.

No.16. Bristol.

May 11th.

1 killed.

Marine. Single internal fire grate, with small return tube, 7ft. 9in. long, 5ft. 4in. diameter, 3/8 inch plates, tube 2ft. 7in. diameter, 1/4 inch plates, 62 lbs. pressure. Tube collapsed and rent open owing to its weak, corroded, and deteriorated condition, and the contents issued so violently, as to cause much damage to the boat.

No.17. Hull. (Fig. 10.)

May 12th.

2 killed, 2 injured.

One of two. Plain Cylinder, 4ft. 9in. long, 3ft. diameter, 1/4 inch plates, 25 lbs. pressure. This was a second-hand boiler, and rent into several pieces just after being put to work, owing to its having become thinned to 1/8 inch by corrosion.



Fig. 10.

No.18. Coatbridge.

May 15th.

1 injured.

Plain Cylinder, flat ends, 15ft. long, 5ft. diameter, 3/8 inch plates, 30 lbs. pressure. The back end blew out and caused considerable damage, and the boiler was thrown some distance. The end was very insufficiently stayed.

No.19. Gravesend. ([Fig. 11.](#))

May 28th.

2 killed.

One of two. Marine, 13ft. 5in. long, 7ft. 2in. diameter, 5/16 inch plates, 25 lbs. pressure. The fire was in two internal furnace tubes united at the back, and the flame was returned to the front by four smaller tubes. The furnace tubes were of exceedingly weak shape as the sides followed the curve of the shell, but were not attached to it by proper stays, so that the left hand tube collapsed upwards, and one seam rent open and allowed the contents to violently escape. It is probable there may have been greater pressure than usual at the time, but the furnaces without stays were unsafe, even at the ordinary pressure.



Fig. 11.

No.20. Durham. ([Fig. 12.](#))

June 8th.

2 killed.

One of eight. Plain Cylinder, 30ft. long, 6ft. diameter, 3/8 inch plates, 35 lbs. pressure. The plates were arranged longitudinally. Boiler had worked 27 years, and was much deteriorated, and gave way at an old fracture over the grate, and was torn into 4 pieces, which were thrown a great distance.



Fig. 12.

No.21. Huddersfield. ([Fig. 13.](#))

June 20th.

1 killed, 6 injured.

One tube Cornish, 24ft. long, 6ft. diameter. Tube 3ft. 3in. diameter, 3/8 inch plates, 40 lbs. pressure. The seams were arranged diagonally, but the rents had not followed the seams, but had torn the plates. The shell gave way where extensive corrosion had reduced the plates to 1/8 inch in thickness, and all the shell was blown off, and the tube thrown over and turned end for end.

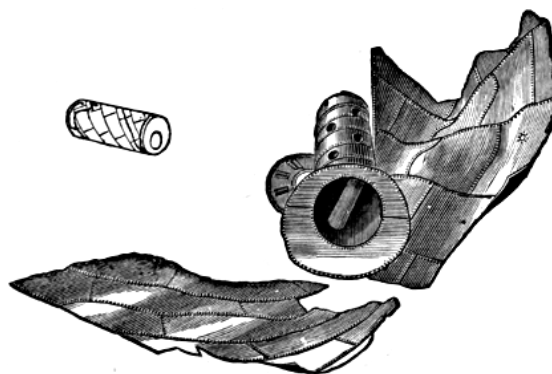

Fig. 13.

No.22.

June 22nd.

none injured.

Two tube Cornish, 27ft. long, 7ft. 6in. diameter. Tube 3ft. diameter, 7/16 inch plates, 70 lbs. pressure. Left hand tube collapsed from end to end owing to its weakness without strengthening rings.

No.23. Halifax.

July 9th.

6 injured.

Two tube Cornish, 20ft. long, 6ft. 3in. diameter. Tube 2ft. 3in. diameter, 3/8 inch plates, 55 lbs. pressure. The shell was blown completely off, leaving the tubes and ends intact. The bottom was extensively corroded, so that the strength of the boiler was so reduced as not to be able to bear the usual pressure.

No.24. Wrexham. ([Fig. 14.](#))

July 9th.

2 injured.

Two Furnace Upright, 22ft. high, 8ft. 10in. diameter, 3/8 inch plates, 14 lbs. pressure. Small piece

was blown out of the bottom, and the issuing contents disturbed the brickwork surrounding the boiler. The plate was corroded to a knife edge in the line of fracture, from the leaking of the adjacent blow-pipe joint.

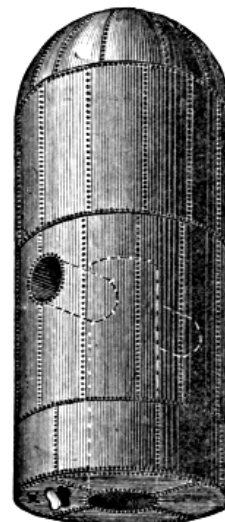

Fig. 14.

No.25. Dundee.

July 13th.

1 killed, 1 injured.

Two tube Cornish, 28ft. 6in. long, 7ft. diameter, 3/8 inch plates. Tube 2ft. 2in. diameter, 7/16 inch plates, 40 lbs. pressure. Both furnaces collapsed, and ruptured from overheating through shortness of water.

No.26. Halifax.

July 14th.

3 injured.

Locomotive, 10ft. 9in. long, 4ft. diameter, 1/2 inch plates, 130 lbs. pressure. Nearly all the barrel was blown away. The inside was very much corroded, and there was a deep furrow at the line of first rupture, caused by the alteration in form of the boiler in the strain of working. This is usually obviated by substituting butt for lap joints, so that the pressure does not tend to alter the circular shape of barrel.

No.27. Limerick.

July 21st.

2 killed, 1 injured.

Locomotive. Few particulars are obtained. The connecting rod broke, and the loose end attached to the crank pierced the boiler, and allowed the contents to issue and scald those near.

No.28. Hanley. ([Fig. 15.](#))

July 31st.

1 killed.

One of three. Plain Cylinder, 36ft. 9in. long, 5ft. diameter, 3/8 inch plates, 50 lbs. pressure. The boiler parted at a seam over the fire bridge. The front end was thrown upwards and to a considerable distance to the front. The back part of the boiler was forced backwards. The first rent took place at a seam-rip at the ruptured seam, and the boiler exploded while the fire was being drawn in order to repair the faulty place.

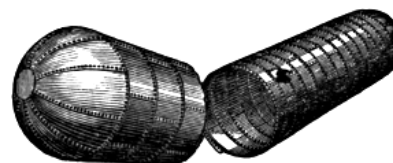

Fig. 15.

No.29. Easter Ross.

August 8th.

2 killed, 3 injured.

Agricultural. It exploded while travelling, by its own steam power. The engine had stuck fast, and extra pressure of steam was raised to try and extricate it. The boiler was torn in pieces, and scattered to a great distance.

No.30. Bilston. ([Fig. 16.](#))

August 17th.

1 killed.

One of two. Plain Cylinder, 30ft. long, 5ft. diameter, 3/8 inch plates, 46 lbs. pressure. The boiler gave way on the side where the plates were overheated by the water being too low, and the front part of the shell was flattened out and thrown some distance to the rear, as its course was influenced by its remaining attached to the rest of the boiler as by a hinge; while the front end was rent into several pieces, and the back end was thrown also to the rear and rolled down a declivity into a stream.



Fig. 16.

No.31. Liverpool. ([Fig. 17.](#))

August 20th.

7 killed, 5 injured.

Two Furnace Chimney Boiler, 42ft. 4in. high, 6ft. 9in. diameter, 1/2 inch plates, 50 lbs. pressure. Nearly half the bottom plate was blown out, and the issuing contents found their way into the furnace and increased the damage. The line of rupture near where it joined the shell was corroded almost to a knife edge, which so reduced its strength as to make it unable to bear the usual working pressure of steam, in addition to that of the column of water in the boiler.

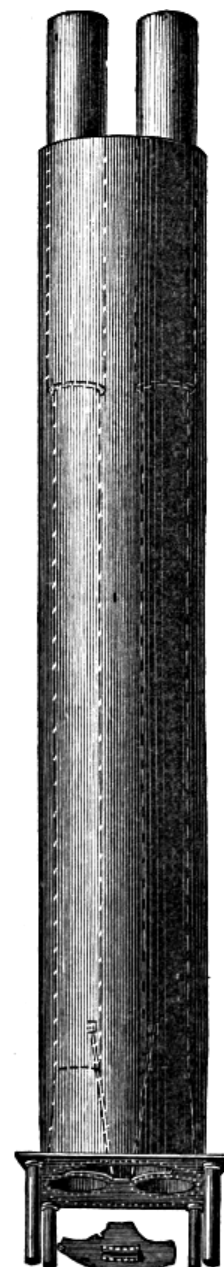

Fig. 17.

No.32. Accrington.

August 31st.

1 killed.

A Kier or Steam Bleaching Chamber, somewhat like [No. 2](#), and not used for generating steam, 9ft. high, 8ft. diameter, 1/2 inch plates, 50 lbs. pressure. The bottom blew out, and the shell was torn to pieces. The cause of explosion was weakness of the ruptured end, and want of care in working.

No.33. Birmingham.

September 11th.

1 killed, 1 injured.

Two tube Cornish. The manlid was wrongly fixed outside with internal clamps. It was being screwed up tighter to stop leaking when the bolt broke, and the lid came off and allowed the contents of the boiler to escape.

No.34. Greatbridge. ([Fig. 18.](#))

September 21st.

none injured.

One of four. One tube, externally fired, 18ft. 6in. long, 6ft. 6in. diameter. Tube 3ft. diameter, $\frac{1}{2}$ inch plates, 40 lbs. pressure. In sketch the shell is shown in dotted lines to allow the tube to be seen. The tube collapsed from end to end and ruptured at two seams, and the contents issued so violently as to knock down the brickwork and displace the boiler. The tube was in a very weak and corroded condition, and unable to bear the usual working pressure.

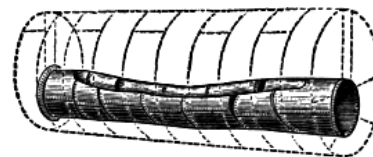

Fig. 18.

No.35. Moxley. ([Fig. 19.](#))

September 28th.

13 killed, 2 injured.

One of four. Four Furnace Upright, 22ft. high, 10ft. 6in. diameter, $\frac{7}{16}$ inch plates, 40 lbs. pressure. The boiler was rent into nine pieces, one of which was not found. The dotted line in sketch shows the outline of the boiler before explosion, and the fragments are arranged as nearly as possible in their original position. The first rent was at a seam-rip opposite the largest furnace, from whence the rupture opened in every direction. This seam-rip must have existed some time before explosion, and must have extended from rivet to rivet, until the boiler was so much weakened as to be unable to bear the usual pressure.

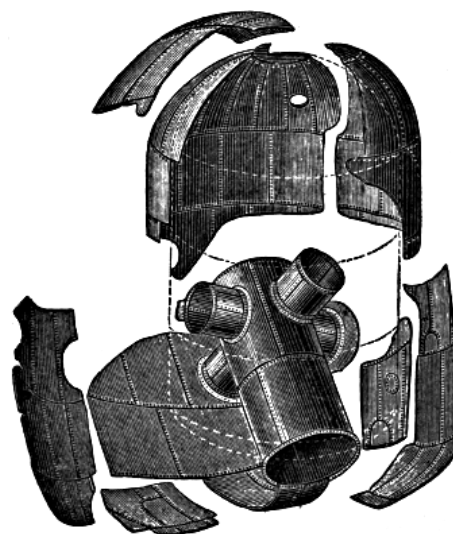

Fig. 19.

No.36. Winsford.

September 30th.

1 killed.

Plain Cylinder. Few particulars obtained. The end over the fire burst open and allowed the contents to escape. A thick accumulation of scale on the bottom had caused the plate to become overheated by preventing proper contact of the water.

No.37. Elsecar. ([Fig. 20.](#))

October 2nd.

2 killed.

One of four. Two Furnace Upright, 21ft. high, 7ft. diameter, $\frac{7}{16}$ inch plates, 58 lbs. pressure. A large piece of plate was blown out of the side of the boiler, and the reaction of the issuing contents threw the boiler over on to its side. The plate was said to be overheated from shortness of water, but as the centre tubes were uninjured, the ruptured plate may have become overheated from the intense heat impinging on one place, causing so rapid a generation of steam as to prevent proper contact of water.

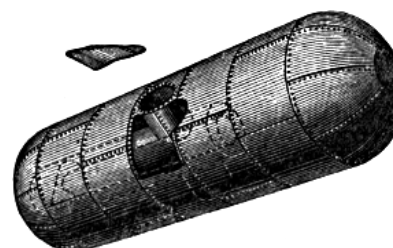

Fig. 20.

No.38. Glasgow.

October 12th.

1 killed, 1 injured.

Plain Cylinder, 39ft. long, 5ft. diameter, $\frac{3}{8}$ inch plates. A small piece of plate about one-and-half-feet area blew out of the bottom, and the contents issued so violently as to do much damage, although the

boiler itself was not otherwise injured. The ruptured plate was corroded, to 1/16 inch thickness by the leaking of seams, caused by the feed water entering close to the bottom of the boiler.

No.39. Swansea.

October 13th.

2 killed, 1 injured.

One of twenty-four. One tube Cornish, worked by two furnaces, 23ft. long, 6ft. 6in. diameter. Tube 3ft. 9in. diameter, 1/2 inch plates, 40 lbs. pressure. The tube was divided by a wall down the middle. The tube collapsed sideways. It was said that one side was overheated through shortness of water, but it is more than probable the explosion was owing to the weakness of so large a tube without strengthening rings.

No.40. Preston.

October 16th.

2 injured.

This was an arrangement of pipes, called an "Economiser," placed in the flues of a set of boilers for heating the feed water. It was shattered into fragments, causing considerable damage. As the whole apparatus was said to be in proper order, the explosion had been attributed to coal gas in the flues, and some peculiarities in the ruptured pipes bear out the supposition.

No.41. London. ([Fig. 21.](#))

October 19th.

6 injured.

Kitchen Boiler, for supplying hot water to the top of a lofty house. It was rectangular, 3ft. 6in. wide, 2ft. 6in. high, and 1ft. deep. The front was blown out and caused considerable damage. The boiler was of most weak shape, and although no pressure of steam was intended, it appeared to have been overlooked that the column of water to the top of the house would give sufficient pressure to make such a boiler unsafe.



Fig. 21.

No.42. London. ([Fig. 22.](#))

October 30th.

2 killed, 10 injured.

One tube Cornish, 15ft. long, 5ft. diameter, 3/8 inch plates, 50 lbs. pressure. Tube oval at fire end, 2ft. 11in. wide, 2ft. 6in. high. Circular beyond bridge, tapering to 2ft. diameter at back end. In sketch outside shell is shown in dotted lines to allow tube to be seen. The front of the tube burst beneath the fire bars, and rent upwards. Tube collapsed beyond bridge and rent open at each side, but remained intact over the fire. The oval part of the tube was of so very weak a shape, that it burst open, and the collapse of the back part followed as a consequence.

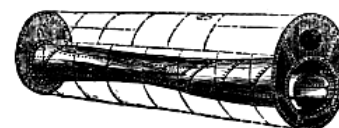

Fig. 22.

No.43. Birmingham. ([Fig. 23.](#))

December 2nd.

1 injured.

Small Portable Boiler, 4ft. 9in. high, 2ft. 3in. diameter, 1/4 inch plates, 40 lbs. pressure. The shell was rent completely off. The explosion arose from the large size of the manhole, which had no guard ring on the edge, and the lid had strained it and caused several cracks, and at last forced itself through the boiler, and the rents spread in every direction, and caused the break up of the boiler.



Fig. 23.

No.44. Newcastle. ([Fig. 24.](#))

December 11th.

3 killed, 3 injured.

Marine Upright, 13ft. 3in. high, 6ft. 6in. diameter, 1/2 inch plates. Internal fire-box 8ft. 6in. high, 6ft. diameter at bottom, 5ft. 3in. diameter at the top, 3/8 inch plates, 50 lbs. pressure. In the sketch the shell is shown in dotted lines to allow the internal fire-box to be seen. The boiler was rent into many pieces, many of which were lost in a river, so that a satisfactory conclusion as to the cause of the explosion was impossible. The boiler was not very firmly stayed, and it is supposed that it was

weakened by corrosion round the fire doors.



Fig. 24.

No.45. Hartlepool.

December 29th.

1 injured.

Marine, with 3 internal fireplaces joined at the back. The back of the junction tube gave way at a place deeply corroded, and allowed the contents of the boiler to escape.

NOTE.—Two more illustrations may be given which are not sufficiently important to include in the above list.

Willenhall. (Fig. 25.)

December 24th.

none injured.

One of two. Plain Cylinder, 25ft. 6in. long, 5ft. 6in. diameter, 3/8 inch plates, 30 lbs. pressure. The water was allowed to get low, and the overheated plates opened and allowed the steam to escape harmlessly.

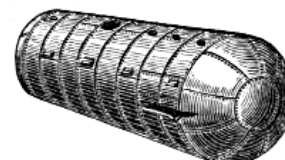

Fig. 25.

Stoke. (Fig. 26.)

December 9th.

none injured.

One of eight. Four Furnace Upright, 22ft. high, 9ft. diameter, 7/16 inch plates, 45 lbs. pressure. The water was allowed to get so low that the shell was overheated and rent, and the side tube slightly collapsed, and the injury was not discovered until the feed water had risen up to the rupture, when it ran into the furnaces without causing any violent explosion, although cold water had been put into a red hot boiler.

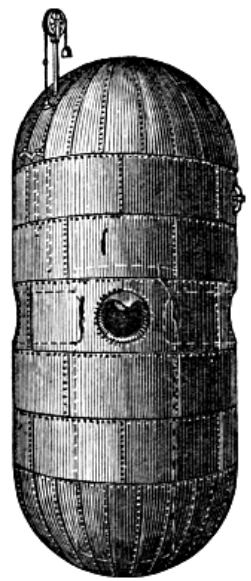

Fig. 26.

STOURBRIDGE:
PRINTED BY R. BROOMHALL, HIGH STREET.

BOILER EXPLOSIONS IN 1869.

No.1. Chesterfield. ([Fig. 1.](#))

January 14th.

4 killed, 2 injured.

One of two. One tube Cornish, 26ft. 6in. long, 6ft. diameter, tube 3ft. 3in. diameter, 3/8 inch plates, 45 lbs. pressure. The gauge glass was broken and the float was either out of order or unobserved, as the water was allowed to get 9 inches below the usual level, so that the crown of the furnace became overheated and collapsed, and rent open where a patch had been put on some little time before.

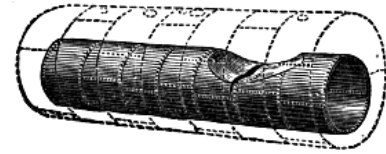

Fig. 1.

No.2. Manchester. ([Fig. 2.](#))

January 22nd.

none injured.

Locomotive. The barrel was 10ft. 6in. long, 4ft. diameter, 7/16 inch plates, 130 lbs. pressure. The engine was 14 years old, and had lately been tested to 180 lbs. hydraulic pressure. The seams near the bottom were so deeply "furrowed" or corroded just above the lap joint in a continuous line that they rent open.



Fig. 2.

No.3. Greatbridge. ([Fig. 3.](#))

January 26th.

1 killed, 1 injured.

One of two. Plain Cylinder, with flat ends, 22ft. long, 4ft. 3in. diameter, 3/8 inch plates, 60 lbs. pressure. There had formerly been a tube with internal furnace, and this had been removed without sufficient stays to compensate for the loss of strength. The plates were arranged in the weakest way with seams in one line from end to end, and the strength of the boiler had been further reduced by very frequent patching. Fracture commenced about the centre of the long seam under the dome, which had gradually ripped from rivet to rivet, until unable to bear the ordinary pressure. The boiler exploded because it was completely worn out, and shows how treacherous and uncertain a boiler becomes by constant patching and alteration. See also [No. 45.](#)

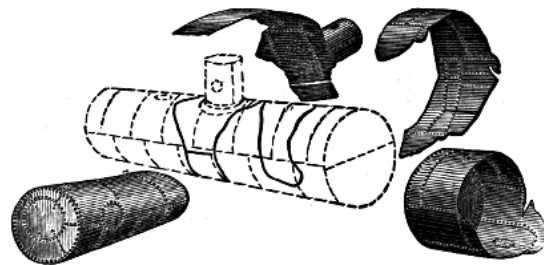

Fig. 3.

No.4. Rotherham. ([Fig. 4.](#))

January 27th.

1 injured.

One of five. Plain cylinder, with dished ends, 36ft. long, 4ft. 6in. diameter, 3/8 inch plates, 55 lbs. pressure. It had worked about 8 years, and was much patched over the fire end, and had lately been put into what was supposed to be thorough repair. As there was no need of an inquest the wreck was quickly cleared and some of the fragments cut up, but enough particulars were obtained to give some idea of the nature of the explosion.

The first rent must have taken place in the bottom seams over the fire, where weakened by frequent repair.

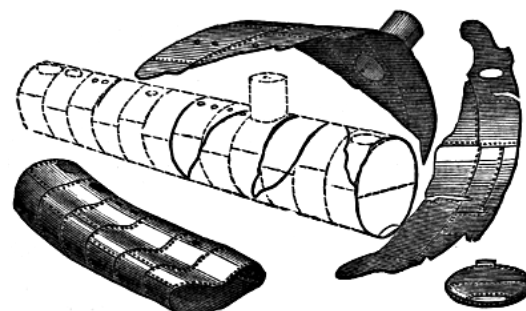

Fig. 4.

One of twelve. Plain cylinder, 13 years old, 30ft. long, 6ft. diameter, $\frac{3}{8}$ inch plates, 35 lbs. pressure. The plates were arranged lengthways, so that the seams were in continuous lines from end to end. This has often been mentioned as giving far less strength than where the plates are placed in rings. There had been considerable repair at various times, and just previous to explosion the boiler had been placed as was supposed in thorough repair, and some new plates had been put over the fireplace. The first rent appears to have taken place where one of these plates joined the old work. The rent quickly extended along a straight seam, and the boiler was blown into three pieces. The explosion was simply caused by the boiler having been weakened by frequent repair until unable to bear the ordinary working pressure. Externally fired boilers, when so frequently patched become treacherous and uncertain, and more especially so when the seams run from end to end. See [No. 59.](#)

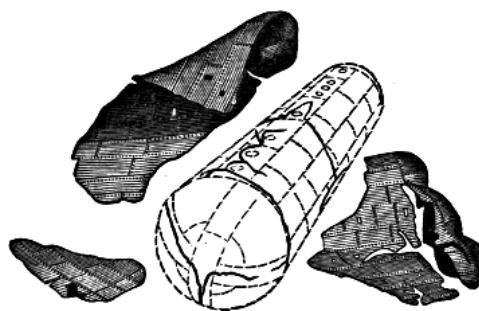

Fig. 5.

No.6. South Wales.

February 12th.

2 injured.

This was a colliery boiler. Very few particulars were obtained. The roof of the engine house was blown off, the boiler was torn from its fittings and turned right round, and knocked down three walls and fell in an upright position.

No.7. Cornwall. ([Fig. 6.](#))

February 15th.

none injured.

One of four. One tube Cornish, 37ft. 6in. long, 7ft. diameter. Tube 4ft. 4in. diameter, $\frac{7}{16}$ inch plates, 40 lbs. pressure.

The tube collapsed for the whole length beyond the bridge, and the back end of boiler was blown out. The portion of tube over the fire was left intact, and the fusible plug was uninjured. The cause of the explosion was the weakness of the tube of such large diameter and so great length. See [No. 57.](#)



Fig. 6.

No.8. Yarmouth. ([Fig. 7.](#))

February 23rd.

3 injured.

Marine, 17ft. long, and 15ft. high, $\frac{3}{8}$ inch plates, 15 lbs. pressure. The top was blown off, the plates having been extensively corroded. The boiler had also been much weakened by altering it from a round to a flat top without sufficient stays.

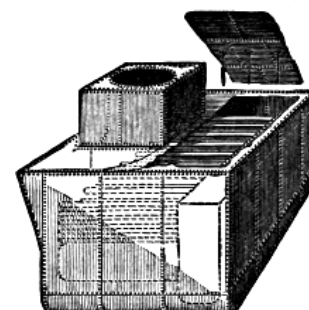

Fig. 7.

No.9. Drogheda.

March 3rd.

2 injured.

The roof of a shed was blown off, but no particulars have been obtained.

No.10. West Bromwich. ([Fig. 8.](#))

March 9th.

3 injured.

One of two. Plain cylinder, 25ft. long, 4ft. 6in. diameter, 3/8 inch plates, 42 lbs. pressure. The boiler had been very frequently repaired, and a seam gave way where a large patch had just previously been put on over the fire, in doing which the rivet holes of the old work had evidently been cracked, rendering the boiler unable to bear the usual working pressure. See [No. 45](#).

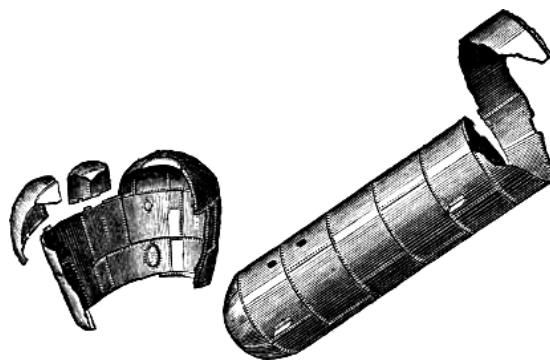

Fig. 8.

No.11. Cornwall.

March 18th.

none injured.

One tube Cornish. The tube collapsed from want of water.

No.12. Broseley. ([Fig. 9](#).)

April 1st.

1 killed, 4 injured.

Multitubular, 9 years old, 8ft. 6in. long, barrel 6ft. long, and 2ft. 4in. diameter, 5/16 inch plates, 50 lbs. pressure. The cylinder was attached to right side of the top of the boiler over the fire box, and on the other side there was a very large manhole, the edges of which were corroded, and so strained and cracked by the screwing up of the manlid, as to be unable to bear the working pressure. The rent started in all directions from the manhole allowing the boiler to split up into three pieces. See [No. 18](#) and [No. 36](#).

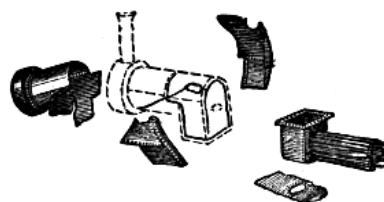

Fig. 9.

No.13. Cornwall.

April 11th.

none injured.

One tube Cornish—but no particulars.

No.14. Barking. ([Fig. 10](#).)

April 19th.

4 killed, 2 injured.

Portable Crane, 8 years old, 8ft. 3in. high, 4ft. 4in. diameter, with internal fire box, 6ft. high and 3ft. 6in. diameter, and chimney passing out at the top, 5/16 inch plates, 40 lbs. pressure. The internal fire box crushed in sideways, and the shell was rent into several pieces. The attachment of the fire box to the shell was made by bending the plates, as shown in enlarged sketch, and this is not so rigid as double angle iron and had evidently strained the chimney tube. This weakness had been so increased by deep corrosion just at the bend of the plates that it had given way. The havoc and loss of life was far greater than would have been supposed possible from so small a boiler, but similar cases are mentioned in [No. 43](#), 1868, and [No. 57](#), 1866.

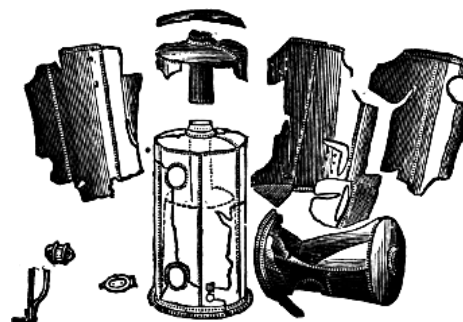

Fig. 10.

No.15. Durham. ([Fig. 11](#).)

April 23rd.

none injured.

One of two. Plain cylinder, with plates arranged lengthways, 30ft. long, 6ft. diameter, 3/8 inch plates, 9 lbs. pressure. A seam gave way on the right side over the fire and immediately rent along the straight seam from end to end, and the boiler was thrown in one mass a great distance to the left. The boiler was very old and much weakened by frequent repair, and at the time of explosion was being imprudently worked at twice its usual pressure for a temporary purpose. See [No. 59](#).

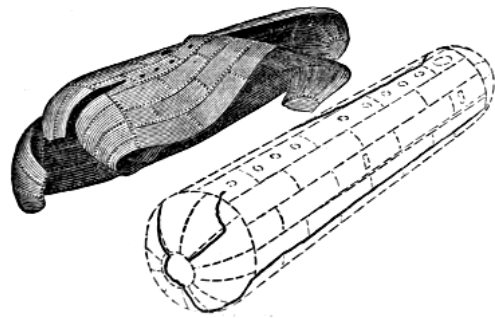

Fig. 11.

No.16. Bury. ([Fig. 12.](#))

April 29th.

none injured.

Double Furnace, internally fired, 28ft. long, 7ft. diameter, 7/16 inch plates, 55 lbs. pressure. Furnace tubes 7ft. long, 3ft. diameter, 3/8 inch plates. The crown of the left hand furnace collapsed and the right hand furnace was slightly altered in shape, as if from overheating by shortness of water, although the true cause was supposed to be the thickening of the water by use of anti-incrustation composition, preventing proper contact of the water with the plates.

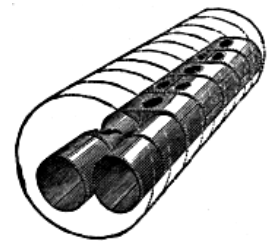

Fig. 12.

No.17. Liverpool. ([Fig. 13.](#))

May 12th.

1 killed, 1 injured.

Plain cylinder, 10ft. long, 3ft. diameter, 3/8 inch plates, 50 lbs. pressure. The ends were flat made of plates, with turned edges, and there was such extensive corrosion on the inside of the bend that the back end came out and was blown 30 yards to the right and rear, the rest of the boiler being thrown to the front. The front plate had been repaired with angle iron where similarly corroded, and the shell was also much patched. The fractured edges were not 1/16 inch thick, so that the boiler was not fit to carry any pressure with safety.



Fig. 13.

No.18. Abingdon. ([Fig. 14.](#))

May 13th.

2 killed, 2 injured.

Revolving Rag boiler, 16ft. long, 6ft. diameter, 7/16 in. plates. There was no fire applied to the boiler itself, but it received steam through one end from other ordinary boilers at 50 lbs. pressure. There were two large rectangular manholes for putting in and taking out the rags, with cast iron frames and lids, attached by bolts with large nuts or clamps.

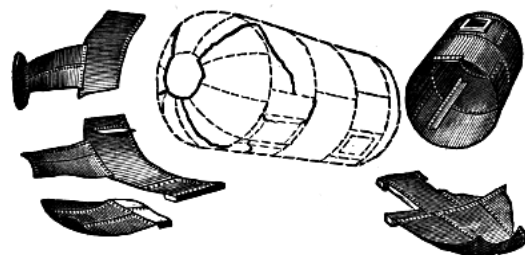

Fig. 14.

The explosion appeared to have taken place when, in revolving, the manlids were approaching the bottom, and the first part to give way was at one of the manholes where the frame was previously broken. The cause of the explosion was the weakness of the manholes, which were very large, and both in the same line, and the attachment of the lids was insecure, as the bolts did not go through the lids, or in any way help to compensate for the large portion of the plate cut away. The boiler was only supported at each end, and had to act as a hollow girder to bear not only its own

weight but the repeated shocks of the heavy material inside falling over and over in addition to the pressure. See [No. 41](#) and [No. 63](#), 1866.

No.19. Glasgow.

May 19th.

1 killed, 1 injured.

Two tube Cornish. One of the tubes collapsed for a length of 8 feet having become overheated through shortness of water.

No.20. Durham. ([Fig. 15.](#))

May 29th.

3 injured.

One of ten, 16 years old, Plain Cylinder with plates arranged lengthways, 34ft. long, 5ft. 6in. diameter, 7/16 inch plates, 50 lbs. pressure. The boiler gave way at one of the long straight seams near the bottom, and rent into five pieces, which were scattered to wide distances, but are so drawn in sketch as to show whereabouts in the boiler they came from. The boiler had been weakened by frequent repair until unable to bear the ordinary pressure. See [No. 59](#).

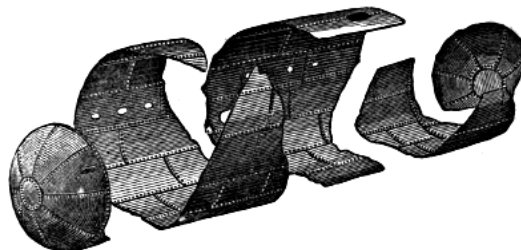

Fig. 15.

No.21. South Wales. ([Fig. 16.](#))

May 31st.

5 killed, 4 injured.

One of three, very old, plain Cylinder, with flat ends, 34ft. long, 6ft. diameter, 3/8 inch plates, 40 lbs. pressure. There had formerly been a tube through the boiler, and when this was taken away new flat ends had been put in without sufficient stays to compensate for the loss of the tube. The front end was blown out, and the reaction sent the boiler upwards and broke it into three pieces. See [No. 47](#).

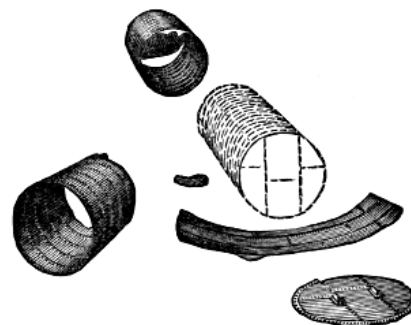

Fig. 16.

No.22. Bingley. ([Fig. 17.](#))

June 9th.

15 killed, 33 injured.

Two tube Cornish, 16ft. long, 6ft. 9in. diameter, 7/16 inch plates, 50 lbs. pressure. Tubes 2ft. 6in. diameter. The bottom was so much corroded that it rent open, and the boiler was torn to pieces which were scattered to wide distances. The boiler had been much neglected and badly used, and the safety valve was insufficient, of bad construction, and overloaded, and the alarm whistle was gagged.

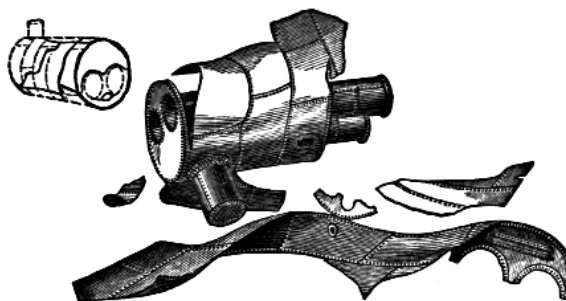

Fig. 17.

No.23. Cornwall.

June 14th.

1 injured.

Cornish, but no particulars have been obtained.

No.24. Durham. ([Fig. 18.](#))

June 16th.

3 killed, 1 injured.

One of three. Plain Cylinder, with plates arranged lengthways, 30ft. long, 6ft. 6in. diameter, 3/8 inch

plates, 28 lbs. pressure, 25 years old.

A seam gave way over the fire where there had been frequent repair, and the boiler was rent into two pieces, which were thrown to some distance. See No. 59.

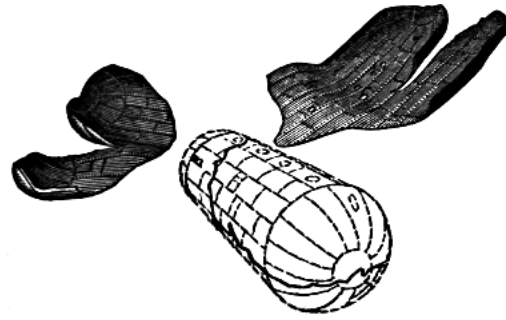

Fig. 18.

No.25. Airdrie.

June 23rd.

2 killed, 3 injured.

Two tube Cornish, 35ft. long, 6ft. diameter. Tube 3ft. 2in. diameter over fire, and 2ft. diameter beyond, 50 lbs. pressure. The tube collapsed over the fire, having been very much weakened by frequent repair.

No.26. Nuneaton. ([Fig. 19.](#))

July 5th.

3 injured.

Plain Cylinder, 25ft. long, 4ft. 6in. diameter, $\frac{7}{16}$ inch plates, 25 lbs. pressure. The plates along the line of rupture were corroded to $\frac{1}{16}$ inch, and in some places much less, so that the boiler was quite unfit for the ordinary working pressure.

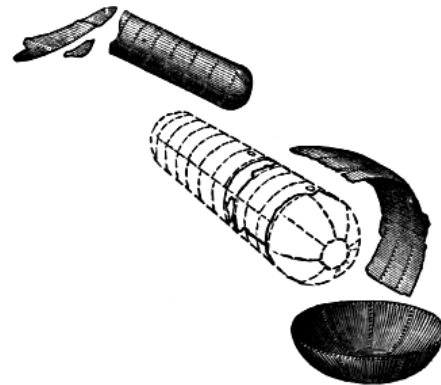

Fig. 19.

No.27. Birmingham. ([Fig. 20.](#))

July 6th.

1 injured.

Small Plain Cylinder, 5ft. long, 2ft. 2in. diameter, $\frac{1}{4}$ inch plates, 25 lbs. pressure. Both sides of the boiler were corroded nearly through so that the strength was entirely gone, and it rent in two at the ordinary pressure.

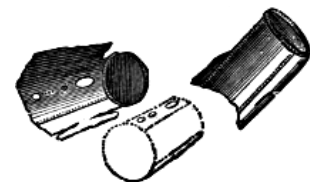

Fig. 20.

No.28. Wishaw.

July 9th.

2 killed, 2 injured.

One of six. Breeches Tube. The tube or combustion chamber collapsed, having become overheated through shortness of water.

No.29. Kidderminster. ([Fig. 21.](#))

July 16th.

1 killed, 4 injured.

Plain Cylinder, 21ft. long, 4ft. 6in. diameter, $\frac{3}{8}$ inch plates, 50 lbs. pressure. The boiler was very old and very much corroded. It had slightly rent open at some former time, and a most wretchedly made patch, shown in enlarged sketch, had been put on to stop leaking, made of thin sheets of iron inside and out and pasteboard between, held together by 36 slight bolts. Of course this patch did not restore the

strength of the boiler, and it soon leaked badly, and the leaking hastened the corrosion of the plate below, until it was nearly eaten away, and quite unfit to bear the working pressure.

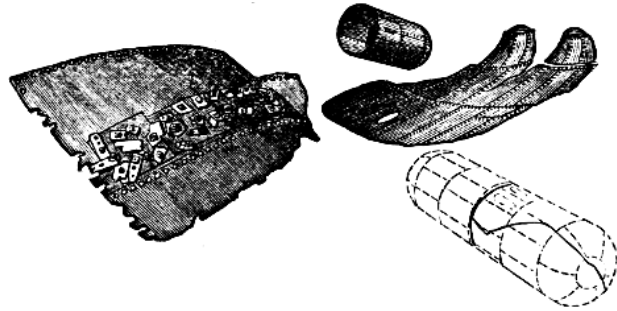

Fig. 21.

No.30. Leeds.

July 19th.

4 injured.

One of three, 12 years old. Two tube Cornish, 32ft. long, 7ft. 6in. diameter. Tube 2ft. 10in. diameter, 3/8 inch plates, 45 lbs. pressure. The right hand tube collapsed from end to end sideways, and ruptured in the furnace, and part of the tube was blown out. The cause of the explosion was simply the weakness of the tube without strengthening rings.

No.31. South Wales. ([Fig. 22.](#))

July 19th.

1 killed.

One of two. Plain Cylinder, 32ft. long, 5ft. diameter, 3/8 inch plates, 40 lbs. pressure. It gave way where deeply corroded on the inside.



Fig. 22.

No.32. Burslem. ([Fig. 23.](#))

July 22nd.

1 killed, 3 injured.

One of six. Plain Cylinder, 36ft. long, 6ft. diameter, 3/8 inch plates, 50 lbs. pressure. Although the boiler was not an old one, it had been much repaired at the seams with strap plates. It was said that the water was very bad, and deposited much mud, which allowed the seams to get overheated and injured. The seam which rent was an original one, and no doubt was ripped as the others had been before repair, and that this rip extended from hole to hole until a rupture at the ordinary pressure was the result.

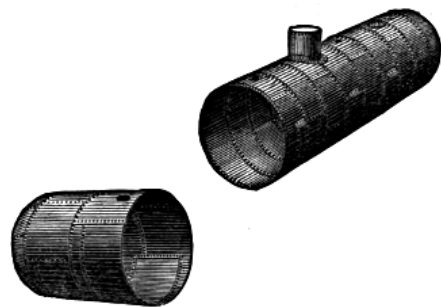

Fig. 23.

No.33. Preston.

August 4th.

1 killed.

Locomotive. In shunting the engine was dragged under a bridge that was not intended for locomotives to pass, and the dome was knocked off.

Marine, 8ft. long, 5ft. 6in. diameter, 3/8 inch plates, 80 lbs. pressure. The flat front end gave way at the angle iron all round, allowing the front with tubes attached, and the shell to be thrown in opposite directions.

The front being flat was very weak, and depended for its strength on gusset stays and small bolts connecting the back of the combustion chamber and the round end of the shell. These stays were very defective and insufficient, and the angle iron was bad and not welded into one ring, and the boiler was therefore unfit to bear the ordinary pressure, and gave way at the weakest place.

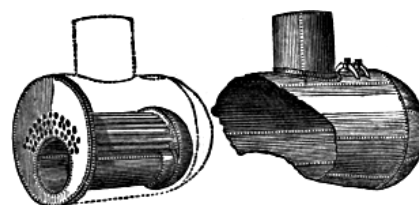

Fig. 24.

No.35. Cornwall. ([Fig. 25.](#))

August 16th.

none injured.

One tube Cornish, 32ft. long, 6ft. 6in. diameter. Tube 4ft. diameter, 7/16 inch plates, 40 to 50 lbs. pressure. There was no steam gauge.

The tube collapsed from end to end, both ends being torn, but the boiler was not moved from its seat. The fusible plug was uninjured. The cause of the explosion was the weakness of the large tube. [See No. 57.](#)

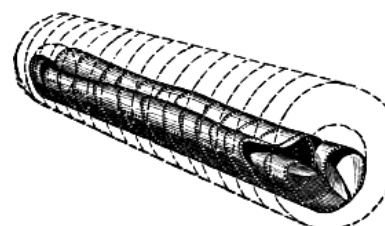

Fig. 25.

No.36. Leicester. ([Fig. 26.](#))

September 1st.

1 injured.

Upright, 5ft. 6in. high, 4ft. diameter, 7/16 inch plates, 40 lbs. pressure. The top of the boiler was blown out. The rent commenced in the manhole, which was unguarded by a ring, and cracks two inches long had existed before explosion. See [No. 12](#) and [No. 18.](#)



Fig. 26.

No.37. Preston. ([Fig. 27.](#))

September 3rd.

1 killed, 1 injured.

One of two. Two tube Cornish, 30ft. long, 7ft. 2in. diameter. Tube 2ft. 8in. in furnaces, and 2ft. 4in. beyond, 3/8 inch plates, 50 lbs. pressure.

The left furnace crown collapsed and ruptured, and the right furnace crown was slightly altered in shape. The two boilers were connected by one feed pipe without back valves, so that the water from this boiler was forced into the other and allowed the tubes to be overheated.

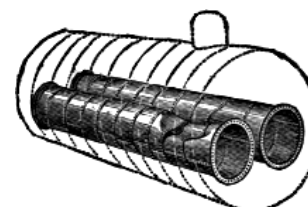

Fig. 27.

No.38. Liverpool. ([Fig. 28.](#))

September 8th.

1 killed, 1 injured.

One tube Cornish, 22ft. 6in. long, 6ft. diameter, 3ft. tube, 7/16 inch plates, 55 lbs. pressure.

The tube collapsed over the fire. It was so much thinned by corrosion, and so many of the rivet heads were eaten off, that there was not strength left to bear the ordinary pressure.

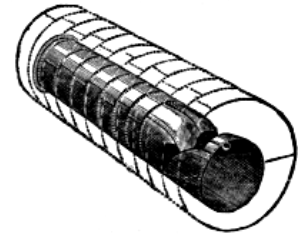

Fig. 28.

No.39. Boxmoor. ([Fig. 29.](#))

September 10th.

1 killed, 4 injured.

One of three. One tube Cornish, 27ft. 3in. long, 5ft. diameter. Tube 2ft. 10in. over furnace, and 2ft. 8in. beyond, 3/8 inch plates, 40 lbs. pressure. One ring of plates was blown out of the back end of shell.

There was such extensive external corrosion on the seating at the bottom that the boiler was unable to bear the working pressure.

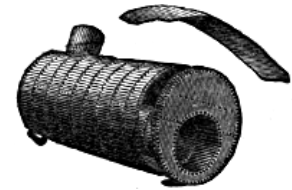

Fig. 29.

No.40. Hull. ([Fig. 30.](#))

September 16th.

1 killed, 1 injured.

Breeches Tube, 13 years old, 30ft. long, 7ft. diameter. Furnace tube 2ft. 10in. diameter. Main tube 3ft. 5½in. diameter, and originally made to work at 20 lbs. pressure, but working lately at 45 lbs. The main tube collapsed. The boiler was not adapted for the pressure at which it was worked, and the tube was much weakened by the overheating caused by a thick incrustation of scale, and was not strengthened by any rings or stays, and was of very weak construction as the plates were arranged lengthways.

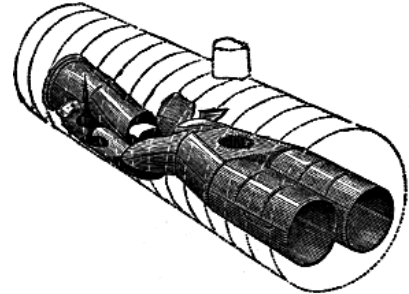

Fig. 30.

No.41. South Wales. ([Fig. 31.](#))

September 26th.

1 killed, 1 injured.

One of two, 20 years old. Plain Cylinder, 36ft. long, 6ft. 6in. diameter, 9/16 inch plates, 35 lbs. pressure.

The plates and rivet heads were very much reduced in thickness by internal corrosion, and in many places were only 1/8 inch or less.

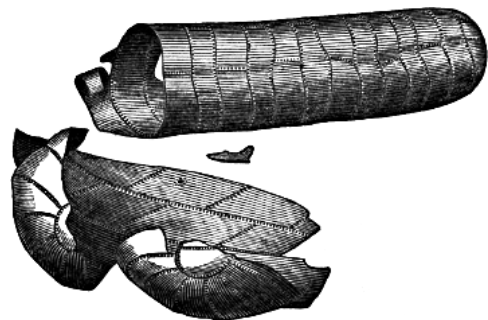

Fig. 31.

No.42. Warrington.

October 6th.

2 killed, 6 injured.

One of seventeen. Two tube Cornish, 22ft. long, 7ft. 6in. diameter. Tube 2ft. 6in. diameter, 7/16 inch

plates, 45 lbs. pressure.

The left hand tube collapsed. The blow-off cock was left open until the water was so low as to allow the tube to be overheated.

No.43. Rowley. ([Fig. 32.](#))

October 13th.

none injured.

Plain Cylinder, with flat ends, 15ft. long, 3ft. 10in. diameter, 3/8 inch plates, 25 lbs. pressure.

The back end ripped all round the angle iron, and was blown out, and the rest of the boiler was thrown forward a considerable distance.

There had once been an internal tube, and when this was taken out the flat end had no stay, and was unfit to bear the usual pressure. See [No. 47.](#)



Fig. 32.

No.44. Newcastle. ([Fig. 33.](#))

October 14th.

2 killed, 5 injured.

Plain Cylinder, with plates arranged lengthways, 29ft. long, 6ft. diameter, 3/8 inch plates, 25 lbs. pressure.

Although only 3 years old the boiler had always given trouble, and had been very frequently repaired. Some new plates had just been put in the bottom, and as the primary rent was in the old plates adjoining them, it is most likely they had caused seam rips in the old metal.

The frequent repair had reduced the strength until unequal to bear the ordinary pressure. See [No. 59.](#)

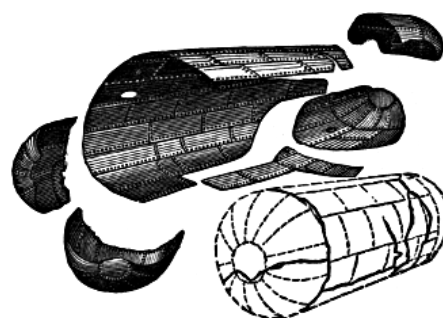

Fig. 33.

No.45. Greatbridge. ([Fig. 34.](#))

October 18th.

2 killed, 2 injured.

One of eight, 15 years old. Plain Cylinder, 40ft. long, 6ft. diameter, 1/2 inch plates. The boiler had originally carried 60 lbs., but lately only 40 lbs. The boiler had been worked very hard, and had been so often repaired, that many of the seams were continuous for a long distance without break of joint, so that its strength was reduced until unable to bear the ordinary pressure.

The treacherousness and uncertainty of boilers with one patch over another has often been pointed out, as in [No. 3](#), [No. 4](#), [No. 10](#), and [No. 32](#).

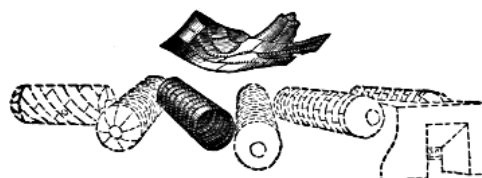

Fig. 34.

No.46. Acorington. ([Fig. 35.](#))

October 19th.

2 killed, 3 injured.

One tube Cornish, 14ft. 6in. long, 5ft. diameter. Tube 2ft. 10in. diameter, 7/16 inch plates, 40 lbs. pressure usually, and sometimes 60 lbs. One ring of plates was blown out of shell.

The boiler was so very badly corroded at the bottom, that the edges of the rent were quite sharp like a knife, and the boiler was therefore unable to bear the usual working pressure. The flues were too narrow to enter for proper inspection, and the bearing surfaces were too wide and retained moisture against the plates.

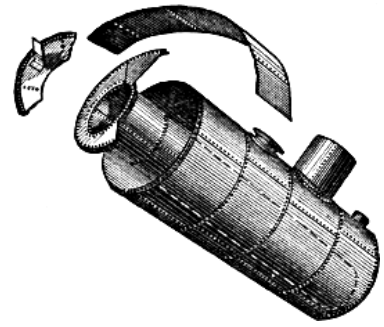

Fig. 35.

No.47. Lydney. ([Fig. 36.](#))

October 28th.

1 killed.

One of four. Plain Cylinder with round front and flat back end, 36ft. long, 6ft. diameter, 7/16 inch plates, 20 lbs. pressure.

The flat end was blown out, the rent extending all round the angle iron.

There had originally been a breeches tube in the boiler with a strong stay to the front end, but when this was taken out no stays were put to the flat end to compensate for the loss of their support. The angle iron attaching the flat end was made in four pieces instead of being welded, and it was reduced to 3/16 inch thick by external corrosion, so that it was not strong enough to bear the ordinary working pressure.

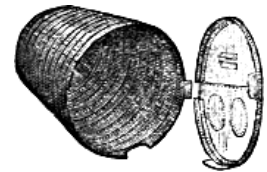

Fig. 36.

The extreme imprudence of altering boilers without due care to preserve their strength has been often pointed out. See [No. 21](#) and [No. 43](#).

No.48. Newcastle. ([Fig. 37.](#))

October 29th.

none injured.

One of six. Plain Cylinder, with plates arranged lengthways, 40ft. long, 5ft. 3in. diameter, 40 lbs. pressure.

The boiler gave way at the fire end, and divided in two, and both pieces were blown to a great distance. The boiler was old and had been much repaired, and the seams running from end to end made it very weak, but the immediate cause of the rupture was supposed to be shortness of water and consequent overheating of the plates. See [No. 59](#).

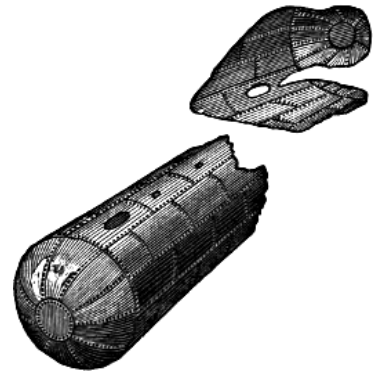

Fig. 37.

No.49. Stockport. ([Fig. 38.](#))

October 30th.

1 killed.

One of eight. Two tube Cornish, 30ft. long, 7ft. 4in. diameter. Tube 2ft. 11in. diameter, 3/8 inch plates, 50 lbs. pressure.

The crown of the right hand tube became overheated from shortness of water, and bulged down and rent half round at the second seam of rivets.

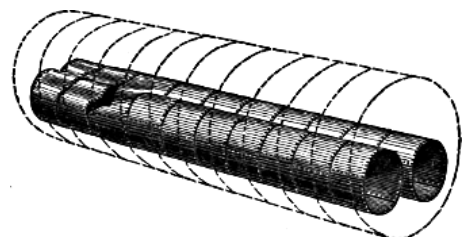

Fig. 38.

No.50. Durham. ([Fig. 39.](#))

November 2nd.

1 injured.

One of four. Plain Cylinder, with the plates arranged lengthways, 38ft. long, 6ft. 6in. diameter, 3/8 inch plates, 35 lbs. pressure. A seam over the fire slightly to the right side gave way where there had been frequent repair to stop leaking. At the part which gave way there had formerly been a side fire, which had perhaps damaged the seams. This boiler was known to have been in bad condition and needing repairs. See [No. 59](#).

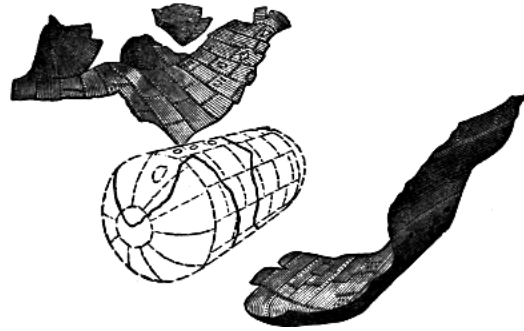

Fig. 39.

No.51. Sheerness. ([Fig. 40.](#))

November 3rd.

11 killed, 7 injured.

One of three. Marine, 15ft. 6in. long, 6ft. diameter. Furnace Tube 2ft. 4in. diameter, 5/8 inch plates, 80 lbs. pressure.

The left hand tube collapsed and ruptured, and the contents issued at the front and scalded all near. The right hand tube was also slightly out of shape on the top.

The cause of the collapse was, that the water had been allowed to get below the crowns of the furnaces. There was no means of ascertaining how the shortness of water occurred, as all were killed who had the opportunity of knowing.

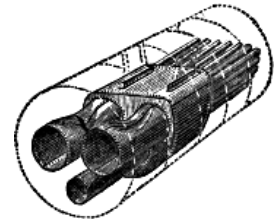

Fig. 40.

No.52. Cornwall. ([Fig. 41.](#))

November 25th.

1 injured.

One of five, 30 years old. One tube Cornish, 36ft. long, 7ft. diameter. Tube 3ft. 10in. diameter, 7/16 inch plates, 40 lbs. pressure.

The shell was rent into several large pieces and thrown to some distance. The tube was also thrown out and broken, chiefly by its fall and striking against walls.

The boiler was corroded very badly on the seating, which must have been known, as there were numerous small screw patches to prevent leaking at the corroded places. The shell was in such bad condition, that it was quite unfit to bear the ordinary working pressure. See [No. 58](#).

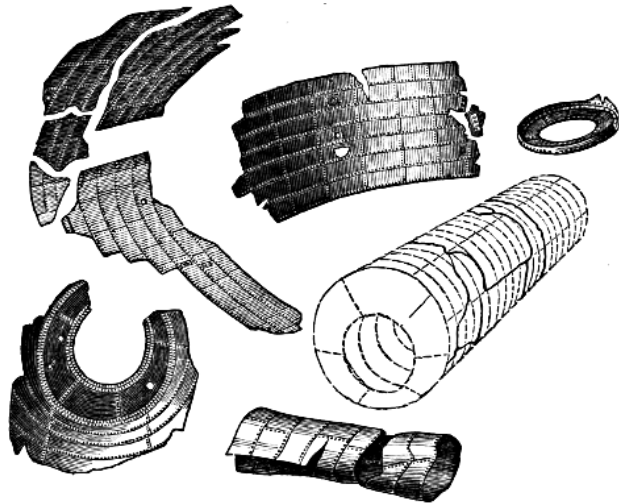

Fig. 41.

No.53. Bilston. ([Fig. 42.](#))

December 3rd.

8 killed, 1 injured.

One of three. Four Furnace Upright, 20ft. high, 10ft. diameter. Centre tube 10ft. high, 4ft. 6in. diameter, side tubes 2ft. diameter, 3/8 inch plates, 35 lbs. pressure.

The central tube collapsed, and the bottom part was blown out, and allowed the contents of the boiler to issue from the bottom into the culvert leading to the stack, and into the necks of the furnaces from which it was heated. The reaction sent the boiler up to a great height, and it divided into eleven fragments, which were very widely scattered. Comparatively little damage was done to the furnaces and premises, only the brickwork surrounding the boiler being thrown down.

Although it had only worked a short time at this place, it was very old, and the central tube was corroded until only 1/8 inch thick in many places, and many of the rivet heads were quite eaten away. It

was altogether so worn out that it was quite unfit to work at any pressure.



Fig. 42

No.54. Cornwall. ([Fig. 43.](#))

December 6th.

none injured.

One tube Cornish, 32ft. long, 6ft. diameter. Tube 4ft. diameter, 7/16 inch plates, 40 to 50 lbs. pressure. The tube collapsed from end to end, and the front portion was blown out with the front end, and the back end was left attached to the shell, and but little moved from its seat.

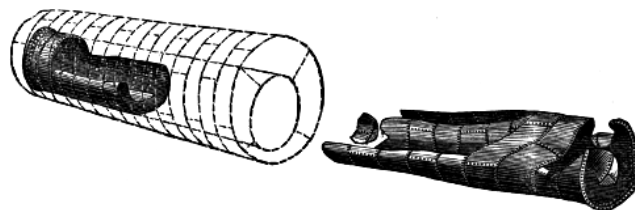

Fig. 43.

The cause was doubtless the weakness of such a large tube.

This is the third explosion at this engine. One of the previous explosions is described at [No. 35.](#)

No.55. Stonehaven.

December 9th.

2 injured.

Locomotive, but no particulars have been obtained.

No.56. Cornwall. ([Fig. 44.](#))

December 10th.

none injured.

One tube Cornish, 26ft. long, 6ft. 6in. diameter, tube 3ft. 10in. diameter, 3/8 inch plates, 40 lbs. pressure. The tube collapsed and ruptured in the central part from weakness.

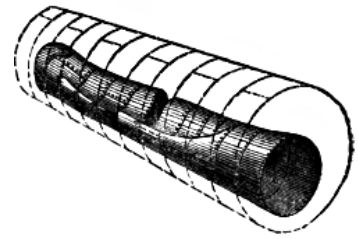

Fig. 44.

No.57. Cornwall. ([Fig. 45.](#))

December 11th.

none injured.

One tube Cornish, 32ft. long, 6ft. 6in. diameter. Tube 4ft. diameter, 3/8 inch plates, 60 lbs. pressure.

It was an old boiler, and some of the plates of the tube were thinned by corrosion, but it had only just been put to work at this place, and burst the first day of working.

The tube collapsed beyond the bridge, and the back part with the back end plate was blown out to a great distance. The front end was also ruptured, and the whole boiler was sent forwards. The tube over the fire had not collapsed. The cause of explosion was the weakness of such a large tube without strengthening rings.

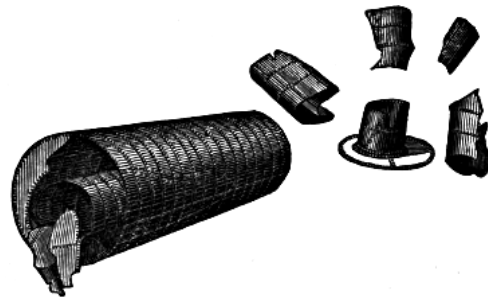

Fig. 45.

Many similar boilers have exploded in the same way from the same cause, as described in [No. 28](#), [No. 30](#), [No. 35](#), [No. 40](#), [No. 54](#), and [No. 56](#).

No.58. Cornwall. ([Fig. 46.](#))

December 14th.

2 killed.

One tube Cornish, 26ft. 8in. long, 6ft. diameter. Tube 3ft. 10in. at front end, and 3ft. beyond, 7/16 inch plates, 40 lbs. pressure.

The shell was rent into several pieces, which were scattered to wide distances. The tube was also thrown to a great distance, but was uninjured. The boiler was 36 years old. The shell was very badly corroded, and temporarily repaired with screw patches to stop leaking, so that the boiler was unfit to bear the usual pressure. See [No. 52](#).

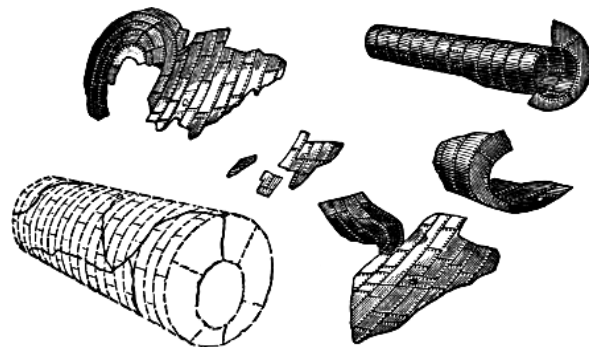

Fig. 46.

No.59. Durham. ([Fig. 47.](#))

December 29th.

2 killed, 1 injured.

One of three. Plain Cylinder, with plates arranged lengthways, 47ft. long, 6ft. diameter, 3/8 inch plates, 30 lbs. pressure. It gave way at the seams over the fire, where the edges of the plates had been injured by injudicious and excessive repairing and caulking. The pieces were sent to great distances. The weakness of boilers with seams from end to end in continuous lines has often been pointed out. Eight of the exploded boilers this year, [No. 5](#), [No. 15](#), [No. 20](#), [No. 24](#), [No. 44](#), [No. 48](#), [No. 50](#), and [No. 59](#), and many others in former years were of the same objectionable construction.

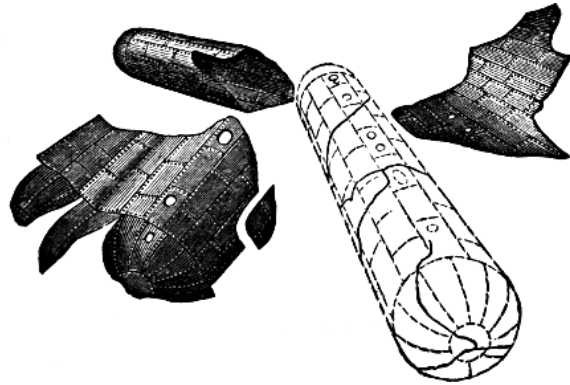

Fig. 47.

The following, not being steam boilers, are not included in the list, but the details may be useful.

Oldbury.

March 10th.

4 killed.

Tar still, 10ft. high, 7ft. diameter, with round top and domed bottom, $\frac{3}{8}$ inch plates, and not intended to work at any pressure. The vapour passing away became congealed, and stopped up the small exit pipe, and pressure accumulated sufficiently to burst the weak shaped vessel.

The bottom came completely out and was left upon the fire, while the top ascended to a great height and fell a long distance away. The loss of life was owing to the material igniting and suffocating those who were thrown down by the explosion.

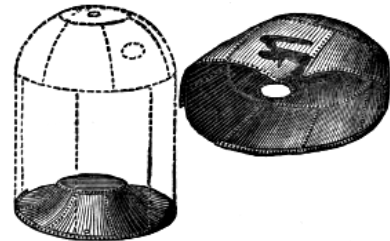

Greatbridge.

December 29th.

2 killed.

Tar still, 12ft. high, 12ft. diameter, $\frac{3}{8}$ inch plates, and not used at any pressure usually.

The upper part separated from the bottom, rending in the angle iron all round. The angle iron near the outlet pipe was corroded nearly away, as shown in enlarged sketch, and the rivet heads were eaten completely off.

It was supposed that the intense frost, during a long stoppage for holidays, had caused the worm to be stopped up and pressure to accumulate, as in the one previously described. But it is perhaps more probable that the vessel gave way because it was corroded so thin in so important a part as the angle iron. The explosion was very slight, the damage and loss of life being from the fierce fire which immediately succeeded it.

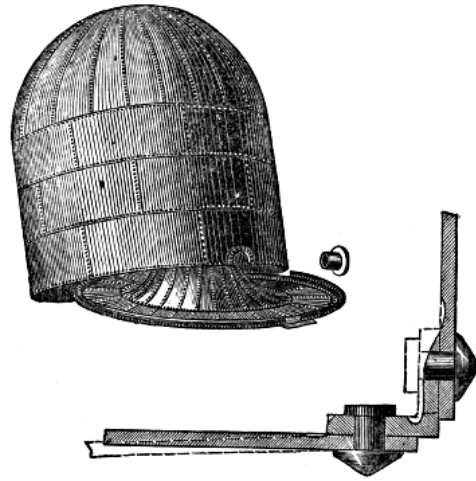

Darlington.

August 26th.

2 injured.

Domestic. Rectangular, and made of wrought iron. The front blew out. It was said that all the communication pipes were shut, and therefore steam accumulated until the weakest part gave way.

Manchester.

December 29th.

1 killed, 1 injured.

The sketch is to a much larger scale than the others.

Domestic, 14in. wide, 11in. high, and about 10in. deep, made of cast iron $\frac{1}{4}$ inch thick. It had close top and two circulating pipes to warm a bath about 10ft. above it. The supply cistern was about 17ft. above the boiler. The front was blown out into the kitchen. It was said that the pipes were frozen, and that steam pressure had thus accumulated.

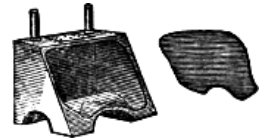

The boiler was of a treacherous material and weak shape, and unfit to bear safely the 7 lbs. pressure the column of water from the cistern would give. The fire also acted on the sides of the boiler without any intervening brickwork. If a closed top boiler is used, there should be a dead weight safety valve to prevent pressure. A far safer plan is to have the kitchen boiler with open top and the circulating heater within it, so that it can never get overheated, as it only obtains its heat from the water in the open boiler.

R. Broomhall, Printer, Stourbridge.

BOILER EXPLOSIONS IN 1870.

No.1. Newcastle. ([Fig. 1.](#))

January 7th.

3 killed, 1 injured.

One of five. Cornish, 13 years old, 30ft. long, 6ft. 6in. diameter. Tube 3ft. 3in. diameter, 3/8 inch plates, 30 lbs. pressure. Tube collapsed sideways from weakness, and the front part and the front plate were blown out, carrying the attendants into a deep and swollen river which ran close in front of boilers.



Fig. 1.

No.2. South Wales. ([Fig. 2.](#))

January 15th.

1 killed, 4 injured.

Plain cylinder, very old, 32ft. long, 5ft. diameter, 7/16 inch plates, 30 lbs. pressure. Externally corroded to 1/16 inch, and gave way near a seam, the front being thrown forward into a house, and the back end 150 yards to the rear, carrying away the stack. It had been badly repaired with bolted patches which had hastened corrosion, and as it was known to be nearly worn out, it was to have been replaced in a few days.

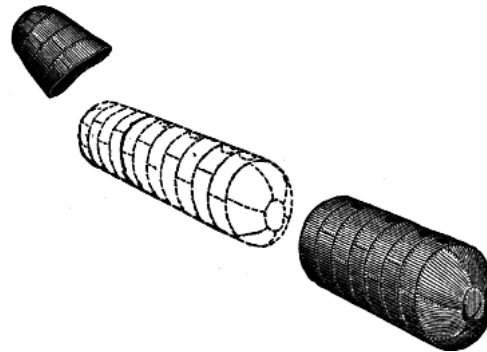

Fig. 2.

No.3. Worksop. ([Fig. 3.](#))

January 28th.

2 killed.

Domestic, 2ft. wide, 1ft. 10in. high, and 7in. deep, 3/8 inch plates, with badly welded joints. The circulating pipes to cistern, 15ft. above, were frozen, and steam pressure accumulated and blew out the front.

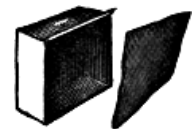

Fig. 3.

No.4. Ipswich. ([Fig. 4.](#))

February 4th.

1 killed.

One of three. Cornish, 7 years old, 24ft. long, 5ft. diameter. Tube 3ft. diameter, 7/16 inch plates, 65 lbs. pressure. The boiler was good and well fitted, but an accumulation of salt on tube caused overheating and rupture of 3rd seam.

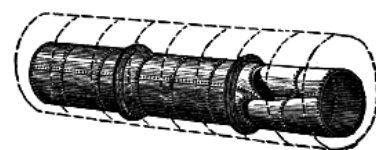

Fig. 4.

No.5. Sheffield. ([Fig. 5.](#))

February 8th.

2 killed, 6 injured.

One of three. Rag Boiler, 2 years old, 11ft. diameter, 9½ft. deep, 7/16 inch plates. Steam was

supplied from the engine exhaust, and was usually about 10 lbs. pressure, but as the boilers from which the steam was originally supplied worked at 60 lbs., it is possible this was sometimes exceeded. The vessel was of very weak shape for even 10 lbs. pressure.

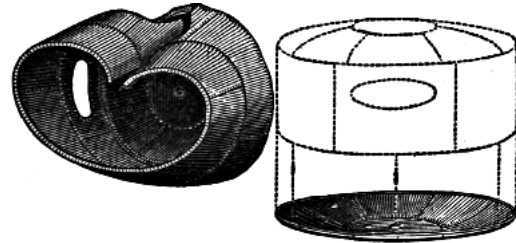

Fig. 5.

No.6. Derby. ([Fig. 6.](#))

February 14th.

1 killed, 2 injured.

Domestic, 1ft. high, 1ft. wide, 8in. across top, and 12in. across bottom, made of cast-iron, 7/16 inch thick. The fire had been let out sometime, and the circulating pipes to cistern 16ft. above were frozen, and on lighting fire steam was formed for which there was no escape, and the boiler was shattered.

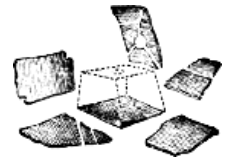

Fig. 6.

No.7. Sheffield. ([Fig. 7.](#))

February 14th.

2 killed, 1 injured.

Domestic, used for warming rooms above, 2ft. 6in. wide, 2ft. high, 9in. across top, and 13in. across bottom, 3/8 inch plates. The circulating pipes to cistern, 12ft. above, were frozen, and steam was formed for which there was no vent, and boiler was rent open. The joints were so badly welded that they soon gave way, and little damage was done to property.

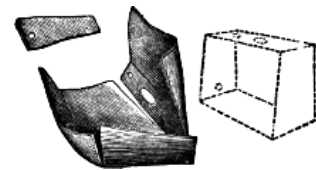

Fig. 7.

No.8. Walsall. ([Fig. 8.](#))

February 19th.

none injured.

One of two. Plain cylinder, 12 years old, 30ft. long, 7ft. diameter, 1/2 inch plates, 50 lbs. pressure. The seams and plates were overheated by shortness of water, and gave way at ordinary pressure. It is supposed the water "kicked" into the other boiler, as there was no back valve to prevent this whenever one boiler happened to be fired a little harder, and consequently at slightly higher pressure than the other. There was no damage except to the boiler.

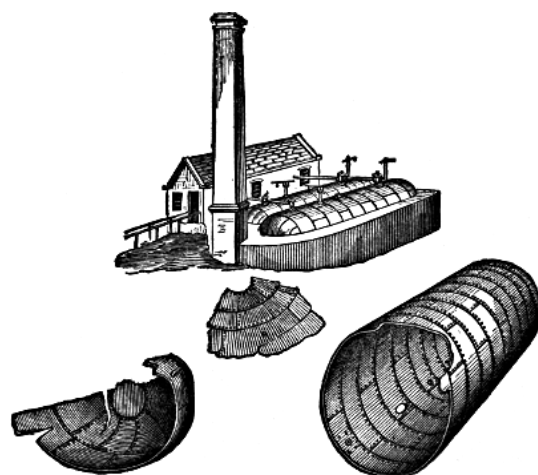

Fig. 8.

No.9. Birmingham. ([Fig. 9.](#))

February 25th.

none injured.

Cornish, 5 years old, 32ft. long, 7ft. diameter. Tube 2ft. 4in. diameter, 7/16 inch plates, 30 lbs. pressure. Cracked along the bottom of front end where internally "furrowed." The boiler was not disturbed, but as the water escaped into an iron furnace the bricks were scattered, but little damage done. The boiler was intended for two tubes, and therefore there was a large part supported only by stays, allowing of a slight movement with varying pressure which facilitates the corrosion in certain

lines of strain called "furring." In this case they were so close to the angle iron and filled with scale that they were difficult to detect.

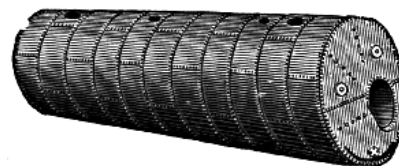

Fig. 9.

No.10. Cornwall. (Fig. 10.)

March 17th.

5 injured.

Upright Boiler, 2 ft. high, 1ft. 9in. diameter, ¼ inch plates. It gave way where deeply corroded externally round the bottom angle iron. The top was blown through the roof and did considerable damage, the bottom being left in the grate.

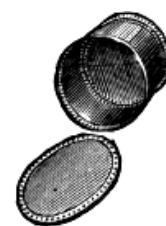

Fig. 10.

No.11. Sheffield. (Fig. 11.)

March 27th.

1 injured.

Agricultural or Contractor's Engine, 9ft. 2in. long, 2ft. 6in. diameter, 3/8 inch plates, 30 lbs. pressure. The heads of stays on each side were corroded outside and drew through the holes, allowing the angles of fire box to open. Boiler was not disturbed and no damage was done.

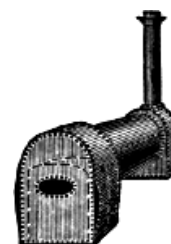

Fig. 11.

No.12. Portsmouth. (Fig. 12.)

March 29th.

3 killed, 1 injured.

One of two. Cornish, 9 years old, 22ft. long, 6ft. diameter. Tube 3ft. diameter, 3/8 inch plates, 40 lbs. pressure. Gave way at mid-feather wall where corroded to 1/32 inch, at a place where flues were too narrow to enter. Two rings of plates were torn out and blown into an adjoining street, while the reaction of the escaping contents forced the boiler into a building in a very singular manner, doing very great damage. This case is of peculiar interest, because although the cause of explosion was so plain to see, all the old theories of decomposition of steam, and ignition of hydrogen, were revived, and it was even stated that "a bad boiler could not explode, as the corroded part would give way, and allow the steam to escape harmlessly," and any cause seemed to be considered more probable than the plain and simple one, that it was corroded to the thickness of card

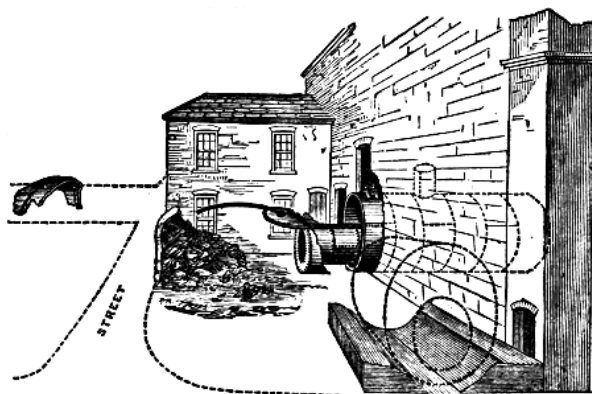

Fig. 12.

was so plain to see, all the old theories of decomposition of steam, and ignition of hydrogen, were revived, and it was even stated that "a bad boiler could not explode, as the corroded part would give way, and allow the steam to escape harmlessly," and any cause seemed to be considered more probable than the plain and simple one, that it was corroded to the thickness of card

board. Like many other examples this explosion shows that however well a boiler is tended, it should be examined in the flues to make sure that it is safe.

No.13. Manchester.

March 30th.

2 killed, 3 injured.

Underground. Some alterations were being done to some brick arching, which fell upon and broke steam pipes, and the escape of steam suffocated those near.

No.14. Warrington. (Fig. 13.)

April 13th.

6 killed, 3 injured.

Lancashire, used for evaporation only, 24ft. 6in. long, 8ft. diameter, 3/8 inch plates, and usually worked with little or no pressure.

The boiler was very old and much patched, and incapable of bearing the 15 lbs. pressure which was temporarily put upon it.

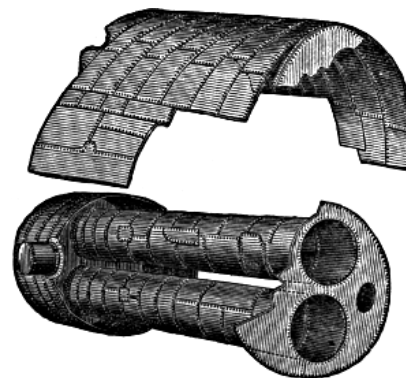

Fig. 13.

No.15. Scotland.

April 18th.

none injured.

Plain cylinder, said to have exploded from shortness of water, but no particulars have been obtained.

No.16. Cornwall. (Fig. 14.)

April 18th.

1 killed, 1 injured.

One of two. Cornish, very old, 34ft. long, 6ft. diameter. Tube 3ft. 10in. diameter, 3/8 inch plates, 50 lbs. pressure. The tube collapsed and the front part was blown out, and the boiler was forced back a little. It was said to have been short of water, but the weakness of a tube of such large diameter was most likely the true cause.

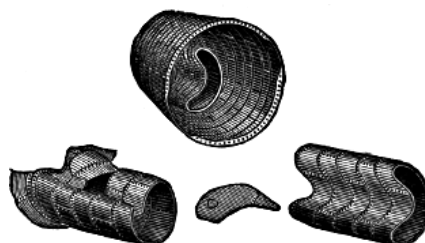

Fig. 14.

No.17. Wellington. (Fig. 15.)

April 22nd.

none injured.

One of two. Balloon, very old, 11ft. high, 9ft. 6in. diameter, 3/8 inch plates, 5 lbs. pressure. The bottom was corroded externally to 1/8 inch, and temporarily repaired with screw patches, and was so reduced in strength that it gave way at the ordinary pressure.

The top was blown about 20 yards away, but little damage was done.

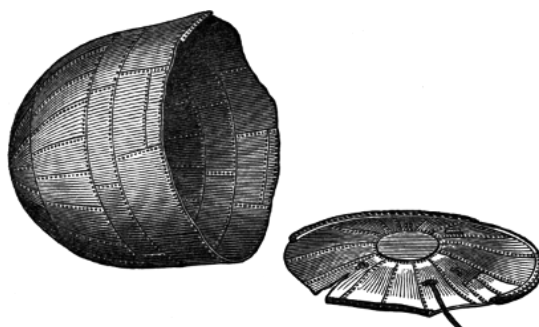

Fig. 15.

No.18. Cornwall.

May.

none injured.

Cornish, 30ft. long, 6ft. diameter. Tube 3ft. 6in. diameter, 40 lbs. pressure. Boiler gave way under bottom where corroded very thin, but little damage was done.

No.19. Darlaston. ([Fig. 16.](#))

May.

none injured.

Cornish, 15ft. long, 4ft. 3in. diameter. Tube 1ft. 6in. diameter, 7/16 inch plates, 40 lbs. pressure. Tube collapsed and ruptured, having been softened by overheating through shortness of water. Very little damage was done.

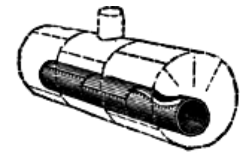

Fig. 16.

No.20. Westbromwich. ([Fig. 17.](#))

May 12th.

2 killed.

One of three. Plain cylinder, 5 years old, 34ft. long, 6ft. diameter, 7/16 inch plates, 45 lbs. pressure. Gave way by the rent of a ripped seam over the fire, which had been repeatedly temporarily patched without restoring the strength or stopping the rip. Three rings were torn out of the middle, while the front end was blown into the bed room of a house, and the back part of the boiler was thrown across a canal through two walls into a distant street. Great damage was done.

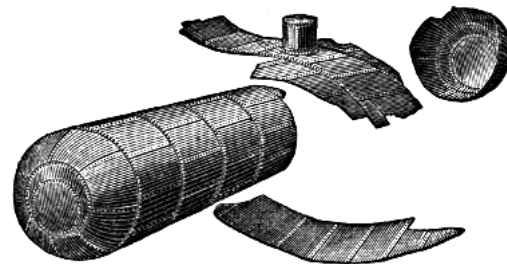

Fig. 17.

No.21. Dublin. ([Fig. 18.](#))

May 18th.

3 killed, 6 injured.

Cornish. Second-hand, but just started at this place, 26ft. long, 6ft. diameter. Tube 3ft. diameter, 3/8 inch plates, 40 lbs. usual pressure. Tube collapsed from end to end. The pressure at time was supposed to be 70 lbs., and as there was no evidence of shortness of water, it is presumed the tube gave way from weakness. The boiler was moved forward about 20 feet, but much damage was done to premises.

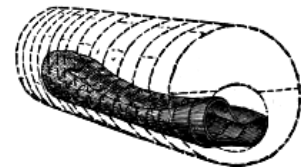

Fig. 18.

No.22. Bury. ([Fig. 19.](#))

May 25th.

none injured.

Domestic Saddle, 5ft. long, 3ft. high, 2ft. 6in. wide, 3/8 inch plates, 15 lbs. pressure, the cistern being 30ft. above. There were no stays between the inner and outer shell, and the space between them was too small to allow proper circulation of water to keep the plates from overheating, so that it was hardly fit for its ordinary pressure, and the top was blown off.



Fig. 19.

No.23. Kidsgrove. ([Fig. 20.](#))

May 26th.

13 killed, 9 injured.

One of three. Four Furnace Upright, 12 years old, 17ft. 6in. high, 9ft. diameter. Centre tube 5ft. 9in. diameter, 3/8 inch plates, 40 lbs. pressure. The centre tube was much corroded on the inside and collapsed inwards from consequent weakness, allowing the contents to issue at the bottom of the boiler, and the reaction sent the whole boiler high up into the air, and on to a roof causing great damage.

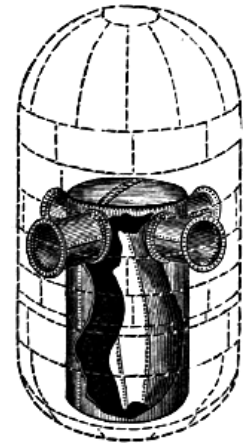

Fig. 20.

No.24. Lowestoft. ([Fig. 21.](#))

May 27th.

2 killed.

Crane or Donkey boiler on board a vessel. About 6ft. high, and 3ft. diameter, 25 lbs. pressure. The internal fire box collapsed from the softening of the plates through shortness of water, the blow off pipe having been left open too long. Little or no injury was done to the ship.

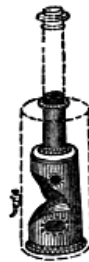

Fig. 21.

No.25. Birmingham. ([Fig. 22.](#))

June 2nd.

2 killed, 1 injured.

Cornish, 6 years old, 21ft. long, 6ft. diameter. Tube 3ft. diameter, 3/8 inch plates, 40 lbs. pressure. The tube was so much weakened by cracks and by being out of true circle, that it collapsed from end to end at the ordinary working pressure.

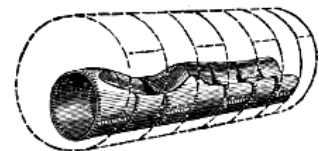

Fig. 22.

No.26. Wigan. ([Fig. 23.](#))

June 6th.

none injured.

One of two. Cornish, 28ft. 7in. long, 5ft. 4in. diameter. Tube 3ft. diameter, slightly oval, 3/8 inch plates, 50 lbs. pressure. Tube collapsed over the fire and ruptured from weakness. The boiler was not moved and the damage was not great.

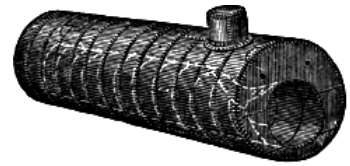

Fig. 23.

No.27. Bury.

June 9th.

1 injured.

Lancashire. The plates were reduced to 1/16 inch by external corrosion, so that the boiler was not able to bear the ordinary pressure, but no details have been obtained.

No.28. Workington. (Fig. 24.)

June 9th.

7 injured.

One of two. Cornish, nearly new, 16ft. long, 5ft. diameter, 3/8 inch plates, 45 lbs. pressure. Three plates over fire collapsed from overheating through shortness of water.

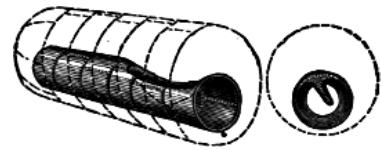

Fig. 24.

No.29. Nottingham. (Fig. 25.)

June 13th.

3 injured.

Ten years old. Plain cylinder, with flat ends, 10ft. long, 2ft. diameter, diagonal seams, 1/4 inch plates, 25 lbs. pressure. The whole shell was blown 80 yards to the front, and the chimney and engine house much damaged. It was much corroded and badly patched, so as to be unfit to carry pressure.

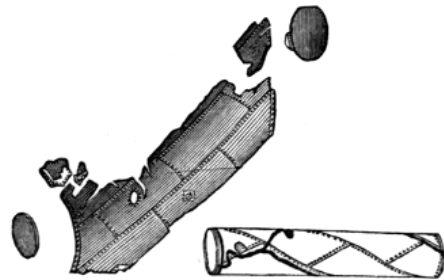

Fig. 25.

No.30. Blackburn. (Fig. 26.)

June 17th.

2 killed, 1 injured.

Sixteen years old. Galloway, 26ft. long, 7ft. diameter, 3/8 inch plates, 56 lbs. pressure. There was a combustion chamber between the furnace tubes and the main tube, and this had been lately repaired insecurely, and gave way and burst upwards. The boiler was not moved, but the contents issued so violently that a good deal of damage was done to surrounding premises.

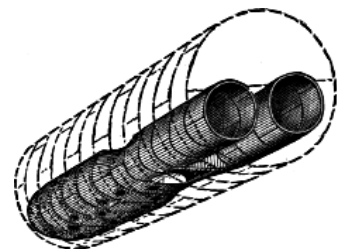

Fig. 26.

No.31. Glasgow. (Fig. 27.)

June 17th.

none injured.

Crane Boiler, about 2 years old, 7ft. high, 4ft. diameter, 3/8 inch plates, 50 lbs. pressure. The internal fire box collapsed and the external shell was blown to pieces. There was no sign of shortness of water, but it is supposed that the fire box was not circular, and therefore too weak to bear the ordinary pressure.

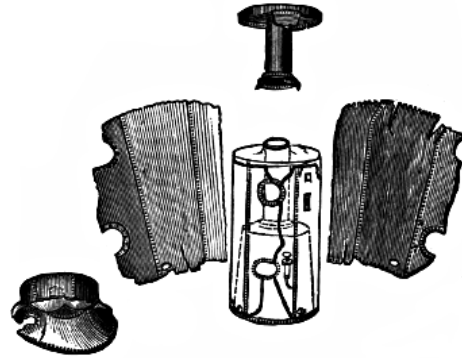

Fig. 27.

No.32. Bilston. ([Fig. 28.](#))

June 21st.

2 killed, 6 injured.

One of seven. Plain cylinder, 30 years old, 30ft. long, 8ft. 3in. diameter, $\frac{1}{2}$ inch plates, 35 lbs. pressure. It gave way over fire place, where it had been weakened by frequent repair, which had caused a seam rip near a patch. The fragments were widely scattered, and much damage was done to the premises. The insecurity of boilers so frequently repaired with patch upon patch has been often pointed out.

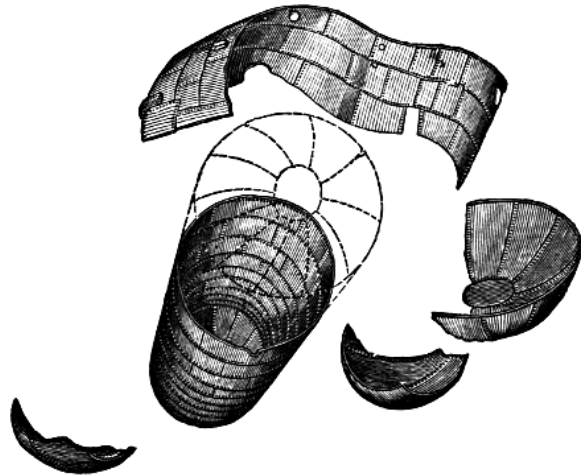

Fig. 28.

No.33. Darlington. ([Fig. 29.](#))

June 24th.

2 injured.

One of twelve. Two Furnace Upright, about 2 years old, 20ft. high, 8ft. diameter, $\frac{7}{16}$ inch plates, 30 lbs. pressure. The water was allowed to run so low that the plates softened by the overheating, and a small piece was blown open and threw down the brickwork.

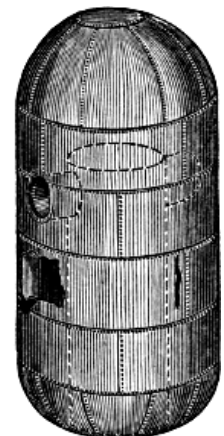

Fig. 29.

No.34. Dudley. ([Fig. 30.](#))

June 25th.

2 injured.

One of two. Balloon, 34 years old, 12ft. diameter, 10ft. high, 3/8 inch plates, 7 lbs. pressure. There were no stays, and the boiler was of very weak shape, and as the boiler it worked with was loaded to 15 lbs., it is presumed this also was exposed to that pressure, and burst in consequence. It gave way at the angle at front over the fire, and was thrown over the engine house.

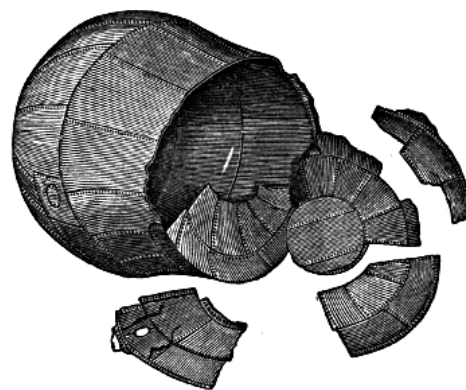

Fig. 30.

No.35. Manchester. ([Fig. 31.](#))

June 27th.

2 killed, 1 injured.

One of four. Galloway, 4 years old, 32ft. long, 8ft. diameter, 7/16 inch plates. Tube 2ft. 10in. diameter, originally intended for 40 lbs., but worked at 65 lbs. pressure. The left hand tube collapsed sideways, having been very much weakened by internal corrosion.

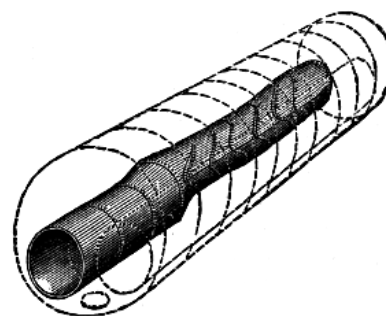

Fig. 31.

No.36.

July 2nd.

1 injured.

Marine. One of the oval tubes collapsed. The boiler was worked at a higher pressure than it was capable of bearing safely, but no particulars have been obtained.

No.37. Scotland.

July 3rd.

2 killed, 3 injured.

Plain Cylinder, 3 years old, 20ft. long, 4ft. diameter, 25lbs. pressure. It was so corroded inside about the water line from bad water, that it gave way at the ordinary pressure. The boiler was thrown 160 yards from its seat.

No.38.

July 29th.

none injured.

Cornish, 26ft. long, 5ft. 9in. diameter, tube 3ft. 6in. diameter, 7/16 inch plates, 35 lbs. pressure. The boiler rent open where externally corroded to 1/32 inch, and 3 widths of plates were torn away.

No.39. Nottingham.

August 12th.

none injured.

Tubulous Boiler, quite new, made entirely of tubes. One tube gave way at defective weld, but no other damage was done.

No.40. Leicester. ([Fig. 32.](#))

August 13th.

4 killed, 5 injured.

Upright Boiler, nearly new, 10ft. high, 5ft. diameter, with internal fire box, 1/2 inch plates, 45 lbs. pressure. The shell was rent into many pieces, which were widely scattered, doing much damage. The safety valve was defective and incapable of relieving the pressure, and the spring indicated wrongly, so that a much higher pressure was used than the boiler could bear safely.

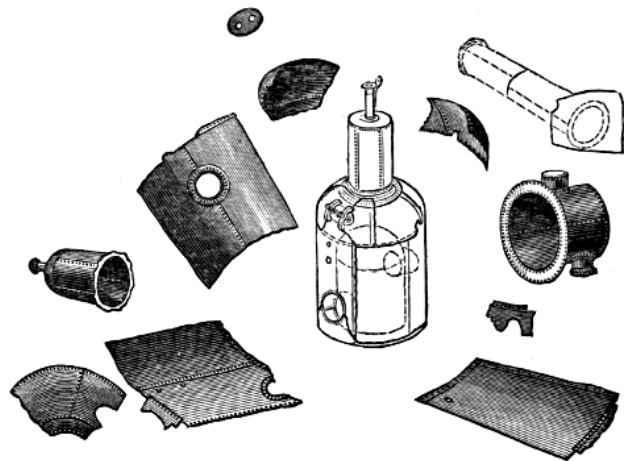

Fig. 32.

No.41. Newcastle-on-Tyne. ([Fig. 33.](#))

Sep. 14th.

5 killed, 20 injured.

One of two. Plain Cylinder, with plates arranged lengthways, 17 years old, 27ft. long, 6ft. diameter, 3/8 inch plates, 30lbs. pressure, mechanically fired. It had just been extensively repaired over the fire, but it gave way at the back end, where a plate had been put in some time before, and it is supposed that a seam rip or injury to the old plate, not visible outside or in, was then set up, which was perhaps increased by the strain of late repairs and gave way as soon as steam was again raised to working pressure. See [No. 55](#) this year and many others in past years of similar construction.

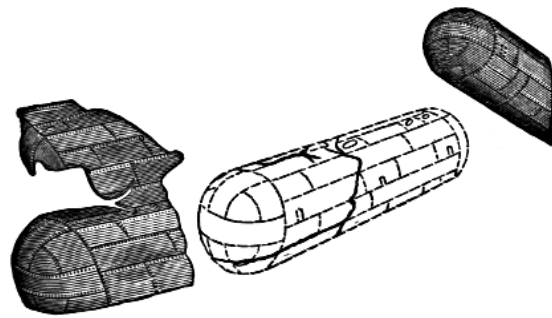

Fig. 33.

No.42. Nottingham. ([Fig. 34.](#))

September 15th.

1 killed.

Tubulous, or all tubes, 1½ years old, 100 lbs. pressure. Steam was being raised with too little water in the boiler, so that the tube became overheated and incapable of bearing pressure, and rent open, and as the boiler was in a small space the steam suffocated the attendant, but the boiler was not disturbed or the premises injured.



Fig. 34.

No.43. Tunstall. ([Fig. 35.](#))

September 17th.

3 killed, 1 injured.

One of four. Plain Cylinder, 8 years old, 36ft. long, 5ft. diameter, 3/8 inch plates, 50 lbs. pressure. It gave way at fifth seam, where a seam rip, caused by bad repair, had so far weakened it that it was

unable to bear the usual pressure, and the ends were blown in opposite directions.

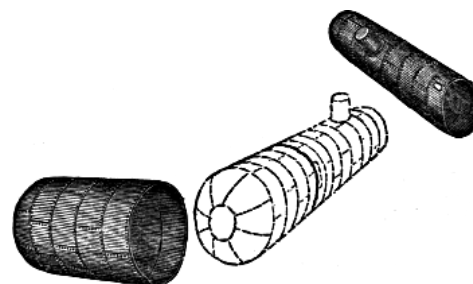

Fig. 35.

No.44. Exeter. ([Fig. 36.](#))

September 27th.

1 killed.

Lancashire, 2 years old, 31ft. long, 7ft. diameter, tube 2ft. 10in. diameter, with 56 Field tubes in each, 3/8 inch plates, 45 lbs. pressure. The right hand tube collapsed and ruptured from softening of plates through shortness of water. The fire was blown out and set the premises on fire and much damage was done.

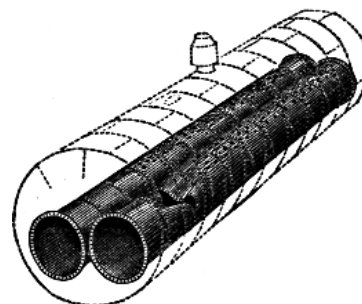

Fig. 36.

No.45. Cardiff.

October 1st.

1 killed, 2 injured.

Locomotive, 4½ years old, 14ft. long, 4ft. diameter, 7/16 inch plates, 120 lbs. pressure. The fire box was reduced to 1/32 inch by corrosion, and unable to bear the usual pressure and rent open, and the escaping contents rushed out at the fire doors and injured those near.

No.46. Liverpool. ([Fig. 37.](#))

October 4th.

4 killed, 4 injured.

Plain Cylinder, 6ft. 6in. long, 3ft. 6in. diameter, 3/8 inch plates, 80 lbs. pressure. The plates were corroded both inside and out, and in some places reduced to less than 1/16 inch in thickness, and it was quite unfit to bear the ordinary pressure. The damage to the surrounding property was very great although the boiler was so small. The shell of the boiler was thrown across a street into an upper room of the house opposite.

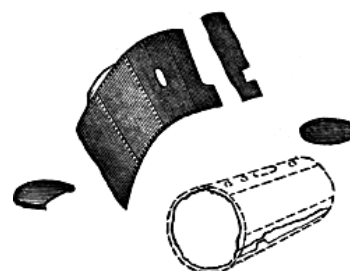

Fig. 37.

No.47. Bathgate.

October 14th.

2 injured.

Rag Boiler. The boiler became exposed to higher pressure than it was intended to bear. The boiler house was destroyed, but no particulars have been obtained.

No.48. Walsall. ([Fig. 38.](#))

October 19th.

1 killed, 2 injured.

Cornish, 7 years old, 13ft. 3in. long, 5ft. 6in. diameter, tube 3ft. 6in. diameter, 3/8 inch plates, and supposed to work at 30 lbs. pressure. The gauge was so out of order that it only indicated half the real pressure. The tube was not in good condition and had leaked very much and was quite unfit for the

pressure of 60 lbs. to which the valve was loaded. The tube collapsed beyond the bridge, and the contents issued at the back and drove the boiler forward 30 feet and into a workshop.

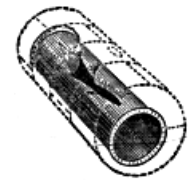

Fig. 38.

No.49. Soho. ([Fig. 39.](#))

October 19th.

1 killed, 1 injured.

One of four. Lancashire, 23ft. long, 7ft. diameter, tube 2ft. 6in. diameter, 30 lbs. pressure, usually, but 15 lbs. at time of explosion. The left side of left tube collapsed and rent owing to shortness of water.

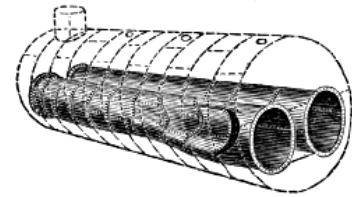

Fig. 39.

No.50. North Wales. ([Fig. 40.](#))

October 19th.

1 killed, 8 injured.

One of two. Cornish, 26ft. long, 5ft. 6in. diameter, tube 3ft. diameter, 7/16 inch plates, 23 lbs. pressure. The bottom was so thinned by external corrosion that it was not able to bear the usual pressure and rent open. The boiler was turned upside down, and the house much injured.

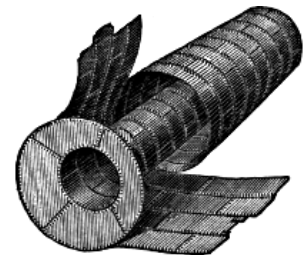

Fig. 40.

No.51. Berwick. ([Fig. 41.](#))

October 21st.

1 killed.

Cornish, 12ft. long, 4ft. 3in. diameter, tube 2ft. 4½in. diameter, 3/8 inch plates, 32 lbs. pressure. The tube collapsed, having become overheated through shortness of water.

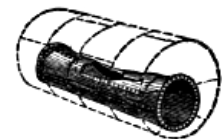

Fig. 41.

No.52. Sheffield. ([Fig. 42.](#))

October 26th.

1 killed, 1 injured.

Locomotive, 11 years old, 9ft. 6in. long, 4ft. diameter, ½ inch plates, 80 lbs. pressure. The top plate over fire box was blown off, having given way along a "furrow" caused by corrosion in a line of strain owing to position of stays. It was in a part of the boiler where it is not usual to find it, and as it could not be seen, it increased until unable to bear the usual pressure.

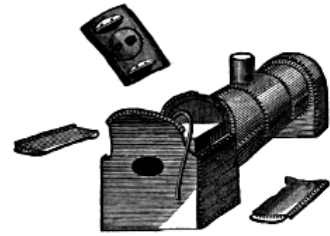

Fig. 42.

No.53. Darlaston. ([Fig. 43.](#))

October 27th.

3 injured.

Plain Cylinder, 22ft. long, 4ft. diameter, 7/16 inch plates, 25 lbs. pressure. The water was allowed to get so low that the sides were softened by overheating, and rent open. The boiler was not moved and only a few bricks were disturbed.



Fig. 43.

No.54. Cornwall. ([Fig. 44.](#))

October 27th.

1 killed.

One of three. Cornish, 12 years old, 36ft. long, 6ft. diameter, tube 3ft. 9in. diameter, 3/8 inch plates, 38 lbs. pressure. The tube collapsed from end to end, the front and central parts being blown out. The shell and back of tube were thrown in one piece to the rear, and much damage was done. It was supposed to have been short of water, because the tube had collapsed, but it is more likely it collapsed because of its weakness without strengthening rings. A tube in this boiler collapsed in a similar way about 5 years previously.

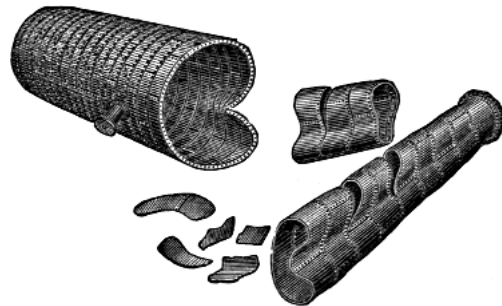

Fig. 44.

No.55. Newcastle. ([Fig. 45.](#))

November 17th.

1 killed, 2 injured.

One of seven. Plain Cylinder, with plates arranged lengthways, 30 years old, 26ft. long, 6ft. diameter, 3/8 inch plates, 35 lbs. pressure, mechanically fired. Gave way at a seam on the right hand side of the fire place, where the insertion of a new plate had caused injury to the old plate, and it divided into two parts which were sent in different directions. The uncertainty and treacherousness of these straight seamed boilers has often been pointed out. See [No. 41](#), and many examples in former years.

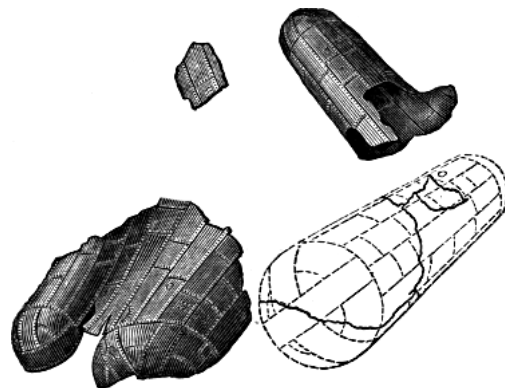

Fig. 45.

No.56. South Wales.

November 19th.

none injured.

Cornish, 7ft. diameter, tube 4ft. diameter, 40 lbs. pressure. Tube collapsed from weakness.

No.57. Shields. ([Fig. 46.](#))

November 24th.

1 killed, 2 injured.

One of two. Marine, second hand when put in 3 years since. Return tube 12ft. 4in. long, slightly oval, 6ft. diameter at front, and 5ft. 6in. at back; tube, oval, 3ft. 10in. wide, and 3ft. deep, 5/16 inch plates, 25 lbs. pressure. The tube collapsed. It was in such a corroded and cracked condition, and so badly repaired, with screw patches, that it was unable to bear the ordinary pressure.

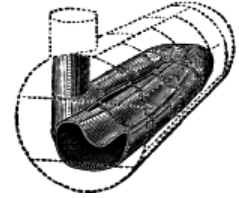

Fig. 46.

No.58. Manchester. (Fig 47.)

December 2nd.

3 injured.

One of two. Balloon, used for evaporating only, nearly new, 9ft. high, and 9ft. diameter, 1/2 inch plates, not usually worked at any pressure. The top was thrown 60 yards away, and the bottom left on furnace. The boiler was temporarily exposed to pressure which it was too weak a shape to bear.



Fig. 47.

No.59. Bilston. (Fig. 48.)

December 2nd.

1 killed, 2 injured.

Plain Cylinder, 5 years old, 14ft. 9in. long, 4ft. 9in. diameter, 3/8 inch plates, 30 lbs. pressure. The water was allowed to get so low that the sides became softened by overheating and rent open, and blew the fire upon those near, but without disturbing the boiler or brickwork.



Fig. 48.

No.60. Hanley. (Fig. 49.)

December 16th.

1 killed, 5 injured.

One of two. Balloon, 30 years old, 15ft. diameter, 3/8 inch plates, worked at 20 lbs. pressure. It rent in two and threw down the engine house and chimney. The boiler was not intended to work at more than 5 lbs. pressure, and was quite unable to bear the extra pressure to which it was exposed.

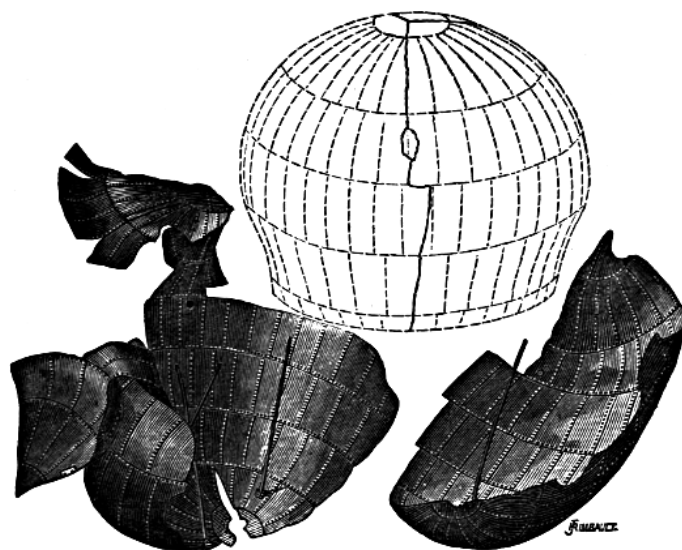

Fig. 49.

No.61. Leeds. (Fig. 50.)

December 24th.

1 injured.

Domestic, wrought iron, welded, 13½ inches wide, 12 inches high. The house had been empty, and the pipes to cistern, 26 feet above, had frozen, and when a fire was lighted the accumulated pressure, having no escape, forced out the front.



Fig. 50.

No.62. Leamington. (Fig. 51.)

December 25th.

none injured.

Domestic Saddle, wrought iron welded, 1ft. 9in. long, and the same width and height. The circulating pipes were stopped by ice, and the accumulated pressure forced down the underside and rent open the joint. The building was injured.



Fig. 51.

No.63. Morley. (Fig. 52.)

December 25th.

none injured.

Domestic Saddle, wrought iron welded, 2ft. 6in. long, 1ft. 6in. wide and high. The circulating pipes being stopped by ice the accumulated pressure forced out the plate on the under side. The building was injured.



Fig. 52.

No.64. Liverpool. (Fig. 53.)

December 25th.

2 injured.

Domestic, 1ft. 8in. wide and high, 1ft. deep, ½ inch cast iron. The circulating pipes were stopped with ice, and the accumulated pressure forced out the front, and did great damage to the house.



Fig. 53.

No.65. London. (Fig. 54.)

December 25th.

1 killed.

Domestic, wrought iron, 1ft. 3in. wide, 1ft. 4in. high, 6in. deep, 3/8 inch thick. The circulating pipes to the cistern about 30ft. above were stopped with ice, and the accumulated pressure rent the boiler in the welded joints, and did great damage to the house.



Fig. 54.

No.66. Dukinfield. (Fig. 55.)

December 26th.

none injured.

Domestic, cast iron, 3/8 inch thick, 1ft. 3in. wide, 1ft. deep. The circulating pipes were frozen, and the pressure accumulated and rent the boiler to fragments and did great damage to the room.

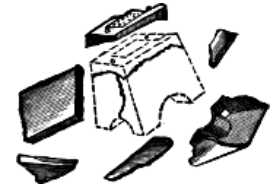

Fig. 55.

No.67. Northallerton. ([Fig. 56.](#))

December 29th.

1 injured.

Locomotive, 20 years old, 12ft. 9in. long, with plates arranged lengthways, 3ft. 8in. diameter, 3/8 inch plates, 80 lbs. pressure. The barrel appears to have given way on the under side near fire box, and opened out and rent into fragments. As the pieces containing the probable first rent were missing, nothing positive could be ascertained. It may have contributed to the rupture that the engine drew from the fire box instead of from the frame.



Fig. 56.

No.68. London. ([Fig. 57.](#))

December 29th.

none injured.

Domestic, Saddle, wrought iron, welded, 1ft. 6in. long, 1ft. 2in. wide, and 1ft. high, 3/8 inch thick. The circulating pipes to cistern 25ft. above were frozen, and the accumulated pressure forced the crown out of under side of boiler, and caused great damage to premises.



Fig. 57.

No.69. London.

December 30th.

none injured.

Domestic, the circulating pipes were frozen, and the accumulated pressure caused the boiler to rent open, but little damage was done.

No.70. Burton.

Date not ascertained.

1 killed.

Plain Cylinder, underground, internally corroded until too weak to bear ordinary pressure.

R. Broomhall, Printer, Stourbridge.

BOILER EXPLOSIONS IN 1871.

No.1. *Tranmere.* ([Fig. 1.](#))

January 1st.

1 injured.

Domestic. Cast-iron, 1ft. 4in. wide, 1ft. high, and 11in. deep. The circulating pipes being frozen the pressure accumulated, and rent the boiler into pieces, doing great damage.

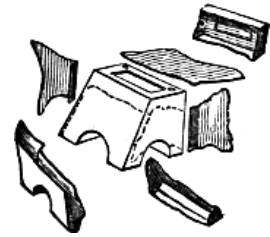

Fig. 1.

No.2. *Rochdale.* ([Fig. 2.](#))

January 2nd.

1 injured.

Plain cylinder, 11ft. long, 3ft. 1in. diameter, 3/8 inch plates, 25 lbs. pressure. Ruptured at a bad patch over grate, around which were many old cracks, and the rent passed along the bottom, and through the unguarded manhole, and round several of the transverse seams, dividing the boiler into 4 or 5 pieces, which were widely scattered, but are arranged in sketch near their original position.

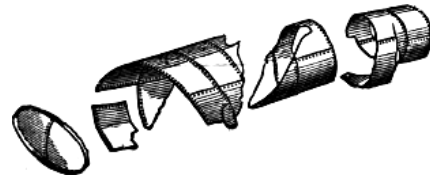

Fig. 2.

No.3.

January 2nd.

none injured.

Cornish, 32ft. long, 6ft. 6in. diameter, 3/8 inch plates, 30 lbs. pressure. Tube ruptured at first seam over the fire from weakness caused by internal corrosion.

No.4. *Middlesbro.* ([Fig. 3.](#))

January 4th.

1 killed.

Domestic, 1ft. 3in. wide, 1ft. high, 11in. deep, 5/16 inch thick. The circulating pipes being frozen, the pressure accumulated and rent the boiler open, doing considerable damage.



Fig. 3.

No.5. *Stirchley.* ([Fig. 4.](#))

January 9th.

1 killed, 4 injured.

One of five, about 30 years old. Lancashire, 18ft. 2in. long, 7ft. 6in. diameter. Tubes 2ft. diameter, 3/8 inch plates, 12 lbs. pressure. Ruptured at corroded steam pipe joint at top of front end, and the rent followed along the angle ring of shell which was also corroded, and then along the seams of some plates in the bottom, placed longitudinally, allowing the top of the boiler to open up like a lid, without moving it much out of its original position.

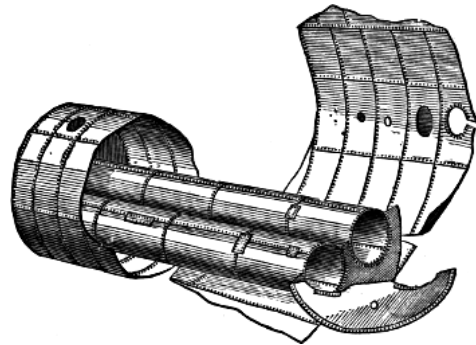

Fig. 4.

No.6. Cornwall.

January 12th.

1 killed.

Cornish, 30ft. long, 6ft. diameter, 7/16 inch plates, 35 lbs. pressure. The ball weight of the safety valve was unusually near the steam pipe, and it is supposed that the boy who was scalded having put his dinner on the pipe to warm, it slipped between the ball and pipe; and that in trying to extricate it he lifted the valve which was held open by the "pasty" wedged under the ball.

No.7. Dalry.

January 13th.

3 injured.

One of two, 25 years old. Plain cylinder, 24ft. long, 4ft. diameter, 5/16 inch plates, 30 lbs. pressure. Gave way at a ring seam where much corroded near the back end, which was blown to the rear, the front end being thrown considerably forwards, and the shell was torn into many fragments which damaged the engine house, and so injured the other boiler that it also was rent into pieces and thrown some distance away. One safety valve was made to serve for the two boilers, and the connecting valve being shut there was no escape from this boiler, so that the bursting pressure soon accumulated. A similar boiler attached to the same engine exploded in April, 1870, and is mentioned as [No. 15](#) in the "records" of that year.

No.8. S. Wales.

January 15th.

none injured

Plain cylinder, 5 years old, 35ft. 6in. long, 4ft. 10in. diameter, 1/2 inch plates, 55 lbs. pressure. Some plates over the fire became red hot from the accumulation of scale some inches thick upon them and gave way, and the reaction of the issuing contents sent the boiler some distance and did much damage.

No.9. Manchester.

January 16th.

1 injured.

Plain cylinder, flat ends, very old, 8ft. 4in. long, 3ft. diameter, 3/8 inch plates, 50 lbs. pressure. The front plate was blown out, and the boiler was thrown backwards for some distance. The boiler was corroded until too weak to bear the ordinary pressure.

No.10. Sunderland.

January 17th.

1 killed, 1 injured.

Marine. The steam expansion joint was placed between two opposite curves in the pipe, and one end drew out when first under pressure.

No.11. Leslie.

January 26th.

2 killed.

Cornish, 10ft. long, 4ft. diameter. Tube 2ft. 4in. diameter, plates 5/16 inch, 40 lbs. pressure. Gave way at bottom where it rested on the brickwork, the plates being completely eaten away by external corrosion.

No.12. Gateshead. ([Fig. 5.](#))

January 27th.

none injured.

Domestic, 3ft. high, 2ft. wide, and 1ft. 1in. deep, 3/8 inch plates. The circulating pipes being frozen, the pressure accumulated, and rent the boiler open doing great damage.

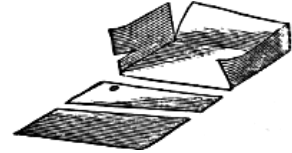

Fig. 5.

No.13. Bradford. ([Fig. 6.](#))

February 1st.

1 killed.

Plain cylinder, 5 years old, flat ends, 7ft. 5in. long, 3ft. 4in. diameter, 3/8 inch plates, 45 lbs. pressure. The safety valve was loaded to 70 lbs., and this pressure was too great for the insufficient stay to the flat end, which was blown out, the boiler being thrown backwards.

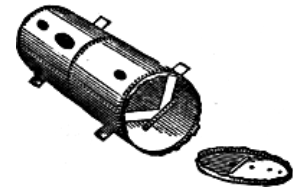

Fig. 6.

No.14. Dover.

February 5th.

1 killed.

Marine, 70 lbs. pressure. The boiler was not moved from its place, and the damage appeared to have been slight, but no particulars have been obtained.

No.15. Newcastle. ([Fig. 7.](#))

Feb. 10th.

none injured.

One of three, 3 years old. Chimney, 27ft. high, 5ft. diameter. Tube 2ft. 9in. diameter, 3/8 inch plates, 25 lbs. pressure. Collapsed about half-way up the tube from overheating through shortness of water.

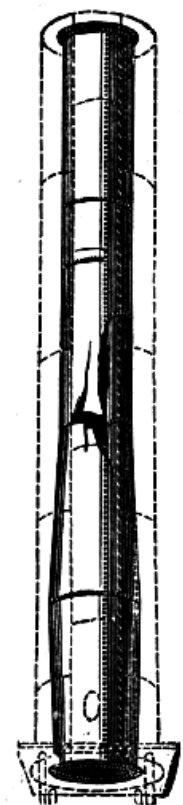

Fig. 7.

No.16. Birmingham. (Fig. 8.)

February 15th.

3 injured.

One of two, 1 year old. Portable upright, 6ft. high, 3ft. diameter, 7/16 inch plates, 25 lbs. pressure. There was but one safety valve, and that was on the other boiler. The junction valve between the boilers was closed, when left for the night, without the fire being properly put out, and there being no outlet for the steam the pressure accumulated, and the boiler ruptured at the unguarded manhole and rent into fragments, much damaging the closely packed houses near.

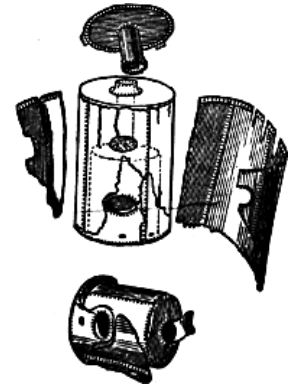

Fig. 8.

No.17. Stockton.

March 8th.

none injured.

Locomotive. The connecting rod broke and pierced the boiler, allowing contents to issue violently. A similar case was mentioned as [No. 27](#), July 21st, 1868, and others have occurred in previous years.

No.18. Bradford. ([Fig. 9.](#))

March 9th.

1 killed, 1 injured.

One of six, 3 years old. Lancashire, 27ft. long, 7ft. diameter. Tubes 2ft. 8in. diameter, slightly oval, 7/16 inch plates, 60 lbs. pressure. The left hand tube collapsed downwards from overheating through shortness of water. The boiler was not moved, and little damage was done to premises.

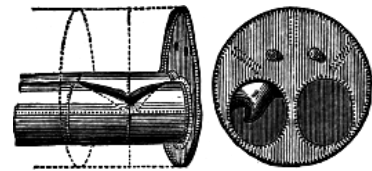

Fig. 9.

No.19. Glasgow.

March 11th.

3 killed, 3 injured.

Rag Boiler. The screws of the manlid were loosened before the steam was exhausted, and the issuing contents scalded those near.

No.20. Wootton Bassett. ([Fig. 10.](#))

March 11th.

2 killed, 1 injured.

Cornish, 12ft. long, 4ft. 8in. diameter. Tube 2ft. 3in. diameter, 3/8 inch plates, 72 lbs. pressure. Tube collapsed downwards from overheating through shortness of water. This was the second time the tube had collapsed, although the boiler had only worked 18 months.

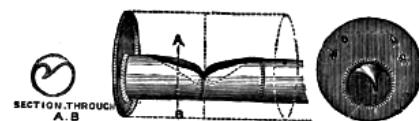

Fig. 10.

No.21. Newcastle. ([Fig. 11.](#))

March 16th.

1 killed.

Plain cylinder, flat ends, 16ft. long, 3ft. 6in. diameter, 5/16 inch plates, 25 lbs. pressure. There being no stays to support the flat ends the varying pressure caused a slight movement backward and forward (sometimes called "drum-head" motion), which facilitated corrosion in certain lines of strain, and produced a "furrow" at the front near the bottom, which rent open. The boiler was not moved, and little

damage was done to the premises.

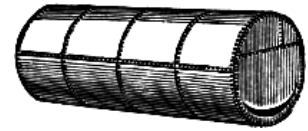

Fig. 11.

No.22. *Brigg.* ([Fig. 12.](#))

March 17th.

1 killed, 1 injured.

One of five, 5 years old. Plain cylinder, 68ft. long, 4ft. 4in. diameter, plates 5/16 inch full, 65 lbs. pressure. Heated by gas. Rent at fourth seam, the front end being thrown a great distance forward, and the back end to the rear, displacing the other 4 boilers. The ruptured seam was next to a patch where the cutting out of the old rivets and putting in of new had caused a seam-rip.

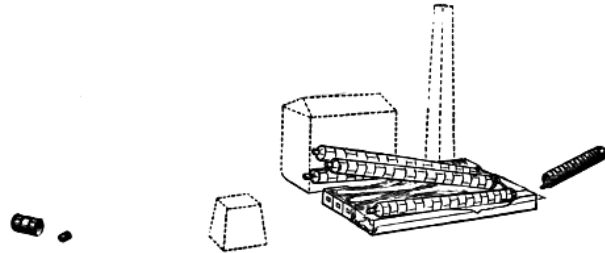

Fig. 12.

No.23. *S. Wales.* ([Fig. 13.](#))

March 18th.

none injured.

One of two, 36 years old. Lancashire, 30ft. long, 9ft. diameter. Tubes 3ft. diameter, 1/2 inch plates, 22 lbs. pressure. The boiler was rent into 3 pieces. Five rings of the back part were torn off and thrown to the rear. Four rings in the middle were opened out flat and fell across the other boiler, and the remaining part of the shell with the tubes were left on the seating. The boiler was old and much patched, and was corroded too thin to bear the usual pressure.

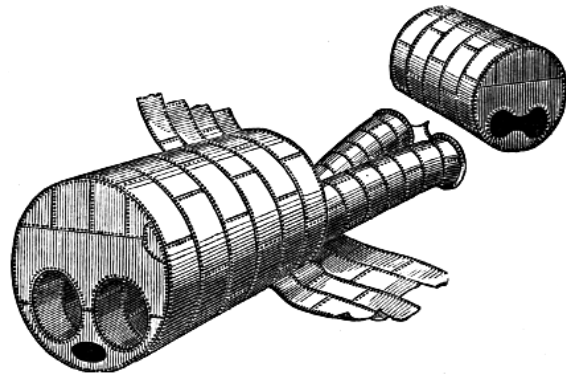

Fig. 13.

No.24. *Lynn.* ([Fig. 14.](#))

March 23rd.

2 killed.

Cornish, 10 years old, 7ft. 3in. long, 3ft. 2in. diameter. Tubes 1ft. 10in. diameter, 3/8 inch plates, 36 lbs. pressure. The tube ruptured at the last ring of plates, and was forced inwards, allowing the contents to issue at the back. The boiler was slightly thrown forward. It was only used occasionally, but was so much reduced by internal corrosion as to be unable to bear the usual pressure.

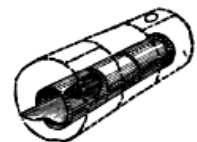

Fig. 14.

No.25. *Northwich.* ([Fig. 15.](#))

May 3rd.

1 killed, 1 injured.

Marine, 7 years old, 9ft. 2in. long, 6ft. 1in. diameter. Furnace tube 2ft. diameter, and 3 inch small tubes, 3/8 inch plates, 81 lbs. pressure. There were two bands as clips round the outside of boiler. Gave way at a seam where some new bottom plates had been inserted, and where the old plate was so thinned by internal corrosion as to be unable to bear the usual pressure. A small plate was blown out and shattered into three pieces, and the boiler was turned end for end.

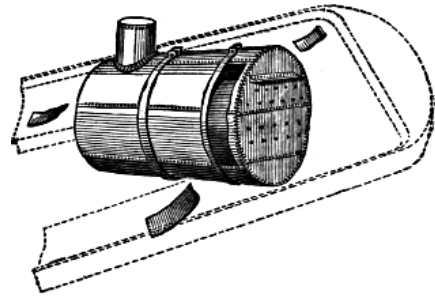

Fig. 15.

No.26. Barnstaple.

May 9th.

1 killed.

Revolving Rag boiler of plain cylindrical shape, with three filling holes. The steam was supplied from other boilers. The central lid was unscrewed, without trying, by a small hole for the purpose, whether there was any pressure, and the lid came off, and the contents issued and scalded the attendant.

No.27. Leamington. ([Fig. 16.](#))

May 18th.

1 killed, 2 injured.

Portable multitubular, 9 years old, 8ft. 6in. long, 2ft. 6in. diameter, 5/16 inch plates, 50 lbs. pressure. The safety valve was fastened down by a nail (A) between the lever and the cover, and in consequence the pressure accumulated to more than the boiler could bear, and it was rent into many pieces, which were widely scattered.

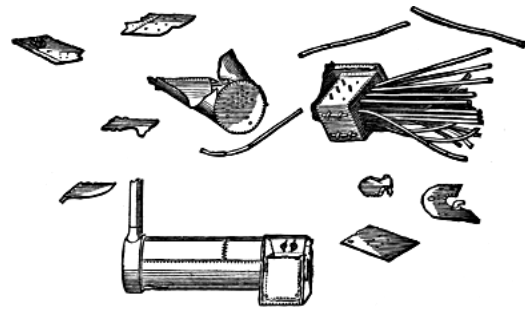
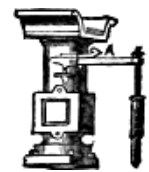

Fig. 16.



No.28.

May 20th.

none injured.

Portable vertical, of peculiar construction, with return down flue tubes, 6ft. high, 4ft. 6in. diameter, 3/8 inch plates, 35 lbs. pressure. The shell was torn off, the bottom having given way through weakness, from want of proper stays, from the crown of the fire box to top of the boiler.

No.29. Hull. ([Fig. 17.](#))

May 22nd.

3 killed, 1 injured.

Lancashire, 22ft. 6in. long, 7ft. 6in. diameter. Tubes 2ft. 10in. diameter, 3/8 inch plates, 70 lbs. pressure. The tube was somewhat corroded on the top, and gave way over the fire from weakness.

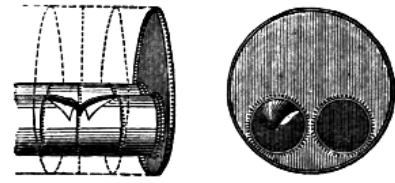

Fig. 17.

No.30. Bath.

May 25th.

1 killed, 1 injured.

Revolving Rag boiler of plain cylindrical shape, but revolving on trunnions, in the opposite direction to [No. 26](#), 12ft. high, 6ft. diameter, 9/16 inch plates, 50 lbs. pressure. The steam was supplied from another boiler. The cover at one end was insecurely fastened and was blown off.

No.31. Oakengates. ([Fig. 18.](#))

June 6th.

none injured.

One of two, 20 years old. Balloon, 14ft. diameter, 3/8 inch plates, 6 lbs. pressure. The pressure was allowed to far exceed the proper height during a temporary stoppage of the engine, and the bottom was rent off, and the top thrown some distance, but very little damage was done.

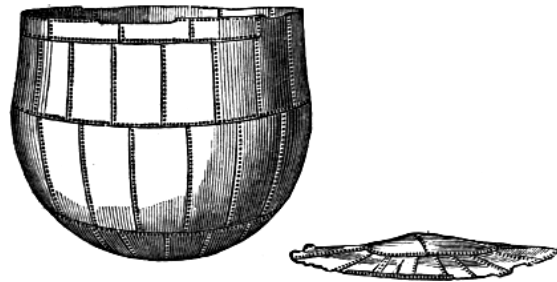

Fig. 18.

No.32. Wellingbro'. ([Fig. 19.](#))

June 17th.

1 killed, 2 injured.

Cornish, 28ft. long, 6ft. diameter. Tube 3ft. diameter, 3/8 inch plates, 40 lbs. pressure. Tube collapsed from weakness, and partly tore away from the back end, and the reaction from the issuing contents forced the boiler back a long way.



Fig. 19.

No.33. Tunstal ([Fig. 20.](#))

June 28th.

8 killed 20 injured

Cornish, 43ft. long, 6ft. 6in. diameter, 7/16 inch plates. Tube 3ft. diameter, 3/8 inch plates, 50 lbs. pressure. The tube collapsed sideways from end to end through weakness, being without strengthening hoops, and with continuous longitudinal seams. The back end and part of the tube were thrown to the rear, and the rest of the boiler was thrown to the front, and separated into several fragments.

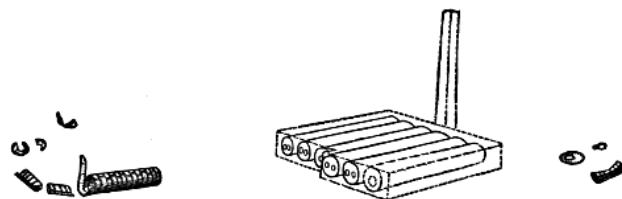

Fig. 20.

The lid of a steam valve was being removed while under pressure, and the steam escaped and scalded those near.

No.35. Rotherham. ([Fig. 21.](#))

July 11th.

none injured.

Cornish, 10 years old, 7ft. long, 6ft. 6in. diameter. Tube 3ft. 3in. diameter, 3/8 inch plates, 45 lbs. pressure. Gave way where much corroded by the damp brickwork of the central wall, and the back ring of plates was torn out, and the boiler turned up on end, and much damage was done to the premises.

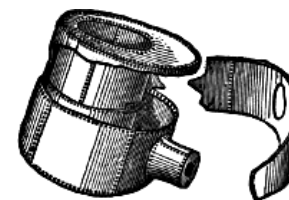

Fig. 21.

No.36.

July 17th.

none injured.

Cornish, 16 years old, 12ft. long, 4ft. diameter, 7/16 inch plates, 48 lbs. pressure. Gave way at the bottom and rent open, a belt of plates being blown away to some distance. The bottom had been extensively corroded, by the boiler being left exposed to wet for many years before it was set at this place, rendering it unfit to bear the usual pressure.

No.37. Cumnock. ([Fig. 22.](#))

July 28th.

1 injured.

One of five, about 20 years old. Plain cylinder, 20ft. long, 4ft. diameter, 5/16 inch plates, 45 lbs. pressure. The boiler had been much patched and altered, and was in very poor condition, and unfit to bear safely the ordinary pressure. Rupture commenced near the feed pipe, and ran along one side and then round each end, both of which were liberated and thrown far away, the barrel of the boiler spreading out on to the neighbouring boilers, one of which was much injured.

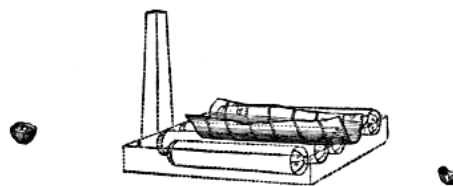

Fig. 22.

No.38. Shields. ([Fig. 23.](#))

August 1st.

1 killed, 7 injured.

Multitubular, 10 years old, 7ft. long, 3ft. 6in. diameter, 5/16 inch plates, 50 lbs. pressure, but valve loaded to 80 lbs. Rupture commenced at the unguarded manhole, and the shell was rent into several pieces which were much scattered. The safety valve was defective, and the boiler had been much weakened by many patches, and was in poor condition and unable to bear the pressure at which it was worked at the time of explosion.

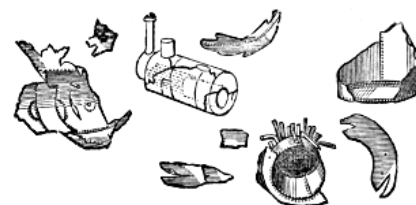

Fig. 23.

No.39. Wakefield.

August 3rd.

1 killed, 1 injured.

One of five. Rag boiler, 5 lbs. pressure from the exhaust steam of an engine. The manhole was of very large size and insecurely fastened, and was blown off.

No.40. Cornwall. ([Fig. 24.](#))

August 17th.

2 killed.

Cornish, 30ft. long, 6ft. 3in. diameter. Tube 4ft. 3in. diameter, 18 lbs. pressure. Ruptured near brickwork at the bottom where much corroded externally, and one ring of plates was rent open. The boiler was displaced, and the premises were greatly damaged.

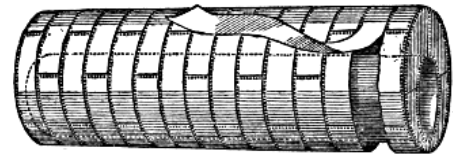

Fig. 24.

No.41. Shields.

August 26th.

none injured.

Chemical pan, 12ft. long, 5ft. 6in. diameter, 3/8 inch plates. The end was blown off, the rivets not being strong enough for the pressure of 35 lbs. as supplied from the boilers.

No.42. Blackburn. (Fig. 25.)

August 29th.

1 killed, 2 injured.

Lancashire, 26ft. long, 6ft. 6in. diameter. Tubes 2ft. 9in. diameter, 3/8 inch plates, 60 lbs. pressure. The left hand tube collapsed from overheating through shortness of water, and the contents issued violently and scalded those near.

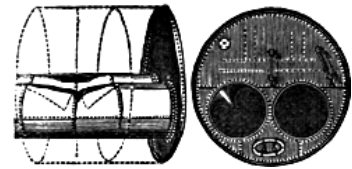

Fig. 25.

No.43. Hereford.

August.

2 injured.

Chemical boiler, Plain cylinder, 12ft. 6in. high, 4ft. 6in. diameter, 3/8 inch plates, with cast-iron hemispherical ends with manhole in each. The pressure of 34 lbs. was obtained from another boiler. The bottom end gave way where the casting was defective, a piece was blown out, and the reaction of the issuing contents projected the boiler through the roof, through which it again descended and did much damage.

No.44. Cardiff. (Fig. 26.)

September 1st.

2 killed, 2 injured.

Marine. Multitubular, 6ft. long, 6ft. diameter, 60 lbs. pressure. The under side of fire box gave way at the front rivets, the heads of which were corroded, and a tongue of plate was torn upwards, allowing the contents to issue so violently, that those near were carried overboard and drowned.

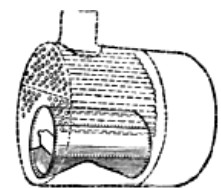

Fig. 26.

No.45. Gresley. (Fig. 27.)

September 2nd.

7 injured.

One of six, 2 years old. Plain cylinder, 40ft. long, 5ft. diameter, 3/8 inch plates, 50 lbs. pressure. This case was peculiar, as the back part of the boiler was found a long way to the front, and the front end in the rear. An accumulation of scale caused pocket to form, and a hole to burn through the bottom over the grate, allowing the contents to issue so violently that the boiler was sent over end for end, when the front end was knocked off and thrown to the rear, and the contents

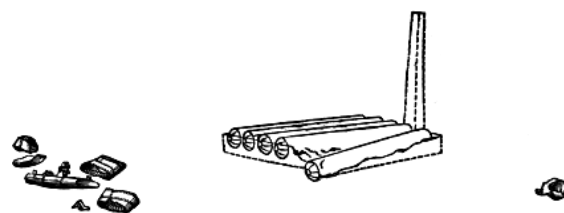

Fig. 27.

then issuing more violently, the reaction sent the rest of the boiler in one piece a great distance to the front, where it fell, and was crushed nearly flat and broken into several fragments.

No.46. Cornwall. ([Fig. 28.](#))

September 16th.

4 injured.

One of two, 18 years old. Cornish, 32ft. 9in. long, 6ft. 6in. diameter. Tube 4ft. diameter, 3/8 inch plates, 45 lbs. pressure. The tube collapsed from end to end, dropping together like an old sack, and cracking at the edges. A small piece at the front end was blown out. The cause was supposed to be shortness of water as there was no gauge glass, but it was far more likely the weakness of so large a tube without strengthening hoops. The pressure was doubtless more than usual, as the engine had made a temporary stand. A similar collapse took place in the next boiler in December, 1869, and is described as [No. 57](#) in the "records" of that year.

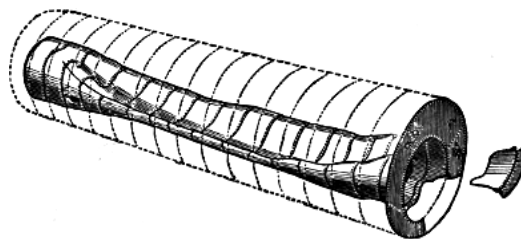

Fig. 28.

No.47. Hull. ([Fig. 29.](#))

September 22nd.

2 injured.

Vertical, with fire box of peculiar corrugated construction, 7ft. 6in. high, 3ft. diameter, 50 lbs. pressure. Gave way round the bottom of fire box where much corroded and rent open, and the reaction of the issuing contents carried the whole boiler to a considerable distance. The pressure gauge had been removed, and the safety valve did not act freely, and the pressure accumulated to more than the boiler could bear.



Fig. 29.

No.48. Grindleton. ([Fig. 30.](#))

September 26th.

1 killed.

Lancashire, 3 years old, 20ft. long, 7ft. diameter. Tube 2ft. 2in. diameter, 3/8 inch plates, 60 lbs. pressure. The boiler gave way at the second ring of plates from the back end, at the side where externally corroded to a knife edge, by brickwork made damp by being next the side of a hill. The rents extended round the boiler, and it was turned nearly bottom upwards, and the shell opened out in the curious way shown in the sketch.

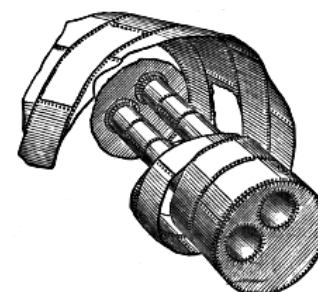

Fig. 30.

No.49. Bradford.

October 9th.

none injured.

One of three. Portable, multitubular, 8ft. long, 2ft. 6in. diameter, 80 lbs. pressure. There was no safety valve, dependence being placed on that of the boiler to which it was connected. Steam was got up without opening the connecting steam cock, and the consequent excessive pressure forced off the front end.

No.50. Tipton.

October 17th.

none injured.

One of twenty, 22 years old. One tube worked by two furnaces, 36ft. long, 6ft. 3in. diameter. Tube from end to left side 2ft. 8in. diameter, 1/2 inch plates, 30 lbs. pressure. The tube collapsed from overheating through shortness of water, and cracked at the edges and allowed the contents to escape without any violence.

No.51. Bury.

October 21st.

2 killed, 1 injured.

A wall fell upon and broke the steam pipes, and the escaping steam scalded those near.

No.52.

October 25th.

2 injured.

Chemical boiler. Plain cylinder, 9ft. 3in. long, 6ft. diameter, 3/8 inch plates. The back end was blown out, and the boiler moved forward a few yards, and the premises were much injured. The outlet pipes were choked up, and more pressure accumulated than it was capable of bearing.

No.53. Chesterfield. ([Fig. 31.](#))

October 25th.

none injured.

Plain cylinder, 6ft. 6in. long, 2ft. 2in. diameter, 5/16 inch plates, 80 to 100 lbs. pressure. The manhole was weak and unguarded with a strengthening ring, and ruptured and allowed the lid to blow out. The rents spread along a part where strength was much reduced by the rivets being countersunk to make room for attachments. The safety valve was defective and overloaded, and there was no gauge, and the boiler was unfit to bear the pressure to which it was exposed.



Fig. 31.

No.54. Northwich.

October 28th.

1 killed, 1 injured.

Chemical. The cover was unscrewed before the pressure was off, and the contents blew out violently and scalded those near.

No.55. Bowling. ([Fig. 32.](#))

October 30th.

1 killed, 1 injured.

One of two, 17 years old. Marine, 12ft. 7in. long, 6ft. 3in. diameter. Tube 4ft. wide, 2ft. 9in. high, 16 lbs. pressure. The tube was much weakened by corrosion and screw-patching and collapsed upwards, with the slightly increased pressure of a temporary stoppage of the engine.

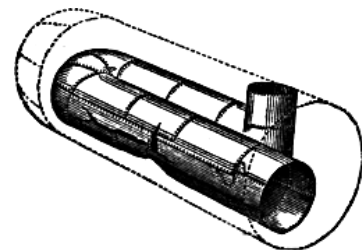

Fig. 32.

No.56. Bilston.

October.

none injured.

Chemical, 9ft. long, slightly oval, 4ft. greatest diameter, 3/8 inch plates, 2 lbs. pressure. Although not at work, it is supposed that a gas was gently passing off through a small pipe, 30ft. long, to a receiver which was under repair, and that this gas being accidentally lighted, communicated through the pipe with that in the boiler and exploded it. One end was blown off, the rupture passing completely round through the solid plate.

No.57. Newcastle. ([Fig. 33.](#))

November 5th.

none injured.

Cornish, 25ft. long, about 6ft. diameter. Tube 3ft. 6in. diameter, 3/8 inch plates, 30 lbs. pressure. Tube collapsed from overheating through shortness of water.

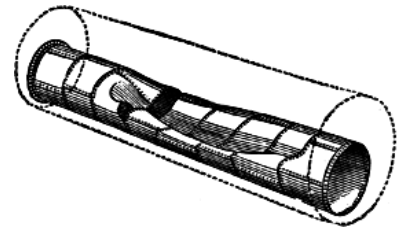

Fig. 33.

No.58. Gravesend. (Fig. 34.)

November 8th.

2 killed.

One of two. Marine, 16ft. 6in. long, 8ft. 4in. diameter. Tube of irregular shape, about 2ft. 10in. high, 3/8 inch plates, 27 lbs. pressure. The gauge was so much out of order, that it only showed 24 lbs. under a real pressure of 80 lbs. The safety valve was defective and overloaded, and the pressure was sufficient to collapse and rupture the side flue, and the contents rushed out at the front.

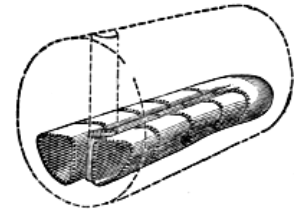

Fig. 34.

No.59. Bilston. (Fig. 35.)

November 12th.

none injured.

One of four. Cornish, about 20 years old, 26ft. long, 6ft. 6in. diameter, 7/16 inch plates, 40 lbs. pressure. Tube 3ft. 9in. diameter had been made in two parts, joined in the centre by a narrow plate 3/8 inch thick, and it collapsed at this joint, so that the top met the bottom, and thus so retarded the issue of the contents after being set in motion, that a shock was produced, which blew out an end and half the tube in opposite directions. The shell was left resting in its seat, and little damage was done to premises. The tube had much the appearance of collapse from shortness of water, but the most probable cause was that it was too weak without strengthening hoops to bear the ordinary pressure with safety.

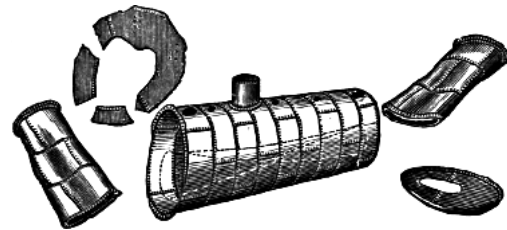

Fig. 35.

No.60. Diss. (Fig. 36.)

November 11th.

2 killed.

Portable, multitubular, about 10 years old, 8ft. 3in. long, 2ft. 7in. diameter, 3/8 inch plates, 30 lbs. pressure. The bottom of the smoke box was reduced by external corrosion to less than 1/16 inch in thickness, and was consequently unable to bear the ordinary pressure, and a piece was blown out, and the reaction of issuing contents displaced the boiler a little and much damaged the premises.

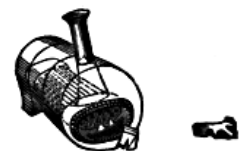

Fig. 36.

No.61. Rotherham.

November 18th.

1 killed.

The screws of a manhole were loosened while the pressure remained in the boiler, and the lid was blown off.

No.62. Newcastle.

November 25th.

1 killed.

One of twelve. Chimney, 28ft. high, 6ft. diameter. Tube 2ft. 5in. diameter, 3/8 inch plates, 25 lbs. pressure. The blow pipe was left open while some men were inside repairing, and the steam and water

from the blow-off of another boiler in the same pipe was forced in upon them.

No.63. Cradley.

December 8th.

1 injured.

Locomotive, 11ft. long, 3ft. diameter, 3/8 inch plates, 95 lbs. pressure. The pressure amounted to about 134 lbs. during a temporary effort to get up a steep curved incline, and the fire box was forced inwards and the outside shell outwards, and the stays drawn, but little other damage was done.

No.64. Middlesbro'. (Fig. 37.)

December 13th.

1 injured.

Locomotive, 18ft. 6in. long, 4ft. diameter, 7/16 inch plates, 120 lbs. pressure. Gave way under bottom of barrel where "furrowed" by the combined action of corrosion and the strain upon the plates, by attachment to the frame of the engine.

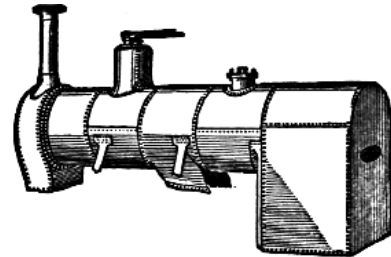

Fig. 37.

No.65. Westbromwich. (Fig. 38.)

December 28th.

1 injured.

One of five, 23 years old. Balloon, 16ft. diameter, 3/8 inch plates, 5 lbs. pressure. It ruptured at the back where the plates in contact with brickwork were reduced by external corrosion, and the bottom was forced down upon the grate, and the top rolled over on to its side. The boiler was not being used, although connected with the other at work. The strain upon the bottom was increased by the boiler being over full and nearly to the brim. Those near were drenched with nearly cold water from it when it upset.

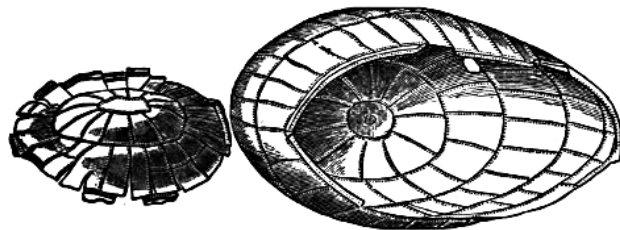

Fig. 38.

No.66. Glasgow. (Fig. 39.)

December 30th.

11 killed, 30 injured.

Portable upright, about 8 years old, 11ft. 4in. high, 4ft. diameter, 3/8 inch plates, 100 lbs. pressure. The internal portion gave way where attached to the fire holes and collapsed inwards, and the reaction of the issuing contents forced the boiler up some distance on to the top of a house. The safety valve did not act properly, and the pressure appears to have accumulated to more than the boiler could bear, during a temporary stoppage of the engine.

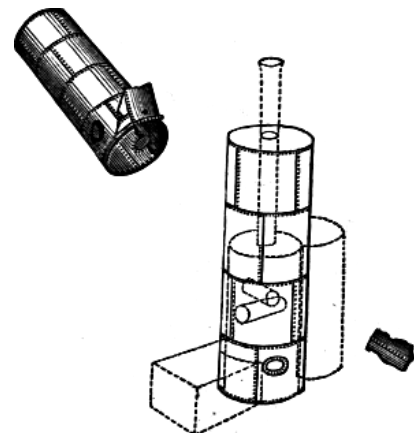

Fig. 39.

Transcriber's note:

In the Conclusions section, several figures are placed out of order as in the original.

Several (apparently) missing punctuation marks have been added.

The word 'guage' appears several times. It has been changed to 'gauge' in each location.

Page numbers for the annual reports have been added.

Other changes made by the transcriber.

Page	As printed	Changed to
94	Uudue	Undue
'66-6	Fig. 5.	Fig. 6.
'66-11	to to	to
'66-11	place	placed
'67-11	he	The
'69-3	reqair	repair
'69-23		(Fig. 38.)
'69-23	(Fig. 38.)	(Fig. 39.)
'69-24	(Fig. 39.)	(Fig. 40.)
'69-24	(Fig. 40.)	(Fig. 41.)
'69-25	discribed	described
'70-14	required	repaired
'70-19	diamer	diameter
'71-16	considerable	considerable

*** END OF THE PROJECT GUTENBERG EBOOK RECORDS OF STEAM BOILER EXPLOSIONS ***

Updated editions will replace the previous one—the old editions will be renamed.

Creating the works from print editions not protected by U.S. copyright law means that no one owns a United States copyright in these works, so the Foundation (and you!) can copy and distribute it in the United States without permission and without paying copyright royalties. Special rules, set forth in the General Terms of Use part of this license, apply to copying and distributing Project Gutenberg™ electronic works to protect the PROJECT GUTENBERG™ concept and trademark. Project Gutenberg is a registered trademark, and may not be used if you charge for an eBook, except by following the terms of the trademark license, including paying royalties for use of the Project Gutenberg trademark. If you do not charge anything for copies of this eBook, complying with the trademark license is very easy. You may use this eBook for nearly any purpose such as creation of derivative works, reports, performances and research. Project Gutenberg eBooks may be modified and printed and given away—you may do practically ANYTHING in the United States with eBooks not protected by U.S. copyright law. Redistribution is subject to the trademark license, especially commercial redistribution.

START: FULL LICENSE

To protect the Project Gutenberg™ mission of promoting the free distribution of electronic works, by using or distributing this work (or any other work associated in any way with the phrase “Project Gutenberg”), you agree to comply with all the terms of the Full Project Gutenberg™ License available with this file or online at www.gutenberg.org/license.

Section 1. General Terms of Use and Redistributing Project Gutenberg™ electronic works

1.A. By reading or using any part of this Project Gutenberg™ electronic work, you indicate that you have read, understand, agree to and accept all the terms of this license and intellectual property (trademark/copyright) agreement. If you do not agree to abide by all the terms of this agreement, you must cease using and return or destroy all copies of Project Gutenberg™ electronic works in your possession. If you paid a fee for obtaining a copy of or access to a Project Gutenberg™ electronic work and you do not agree to be bound by the terms of this agreement, you may obtain a refund from the person or entity to whom you paid the fee as set forth in paragraph 1.E.8.

1.B. “Project Gutenberg” is a registered trademark. It may only be used on or associated in any way with an electronic work by people who agree to be bound by the terms of this agreement. There are a few things that you can do with most Project Gutenberg™ electronic works even without complying with the full terms of this agreement. See paragraph 1.C below. There are a lot of things you can do with Project Gutenberg™ electronic works if you follow the terms of this agreement and help preserve free future access to Project Gutenberg™ electronic works. See paragraph 1.E below.

1.C. The Project Gutenberg Literary Archive Foundation (“the Foundation” or PGLAF), owns a compilation copyright in the collection of Project Gutenberg™ electronic works. Nearly all the individual works in the collection are in the public domain in the United States. If an individual work is unprotected by copyright law in the United States and you are located in the United States, we do not claim a right to prevent you from copying, distributing, performing, displaying or creating derivative works based on the work as long as all references to Project Gutenberg are removed. Of course, we hope that you will support the Project Gutenberg™ mission of promoting free access to electronic works by freely sharing Project Gutenberg™ works in compliance with the terms of this agreement for keeping the Project Gutenberg™ name associated with the work. You can easily comply with the terms of this agreement by keeping this work in the same format with its attached full Project Gutenberg™ License when you share it without charge with others.

1.D. The copyright laws of the place where you are located also govern what you can do with this work. Copyright laws in most countries are in a constant state of change. If you are outside the United States, check the laws of your country in addition to the terms of this agreement before downloading, copying, displaying, performing, distributing or creating derivative works based on this work or any other Project Gutenberg™ work. The Foundation makes no representations concerning the copyright status of any work in any country other than the United States.

1.E. Unless you have removed all references to Project Gutenberg:

1.E.1. The following sentence, with active links to, or other immediate access to, the full Project Gutenberg™ License must appear prominently whenever any copy of a Project Gutenberg™ work (any work on which the phrase “Project Gutenberg” appears, or with which the phrase “Project Gutenberg” is associated) is accessed, displayed, performed, viewed, copied or distributed:

This eBook is for the use of anyone anywhere in the United States and most other parts of the world at no cost and with almost no restrictions whatsoever. You may copy it, give it away or re-use it under the terms of the Project Gutenberg License included with this eBook or online at www.gutenberg.org. If you are not located in the United States, you will have to check the laws of the country where you are located before using this eBook.

1.E.2. If an individual Project Gutenberg™ electronic work is derived from texts not protected by U.S. copyright law (does not contain a notice indicating that it is posted with permission of the copyright holder), the work can be copied and distributed to anyone in the United States without paying any fees or charges. If you are redistributing or providing access to a work with the phrase “Project Gutenberg” associated with or appearing on the work, you must comply either with the requirements of paragraphs 1.E.1 through 1.E.7 or obtain permission for the use of the work and the Project Gutenberg™ trademark as set forth in paragraphs 1.E.8 or 1.E.9.

1.E.3. If an individual Project Gutenberg™ electronic work is posted with the permission of the copyright holder, your use and distribution must comply with both paragraphs 1.E.1 through 1.E.7 and any additional terms imposed by the copyright holder. Additional terms will be linked to the Project Gutenberg™ License for all works posted with the permission of the copyright holder found at the beginning of this work.

1.E.4. Do not unlink or detach or remove the full Project Gutenberg™ License terms from this work, or any files containing a part of this work or any other work associated with Project Gutenberg™.

1.E.5. Do not copy, display, perform, distribute or redistribute this electronic work, or any part of

this electronic work, without prominently displaying the sentence set forth in paragraph 1.E.1 with active links or immediate access to the full terms of the Project Gutenberg™ License.

1.E.6. You may convert to and distribute this work in any binary, compressed, marked up, nonproprietary or proprietary form, including any word processing or hypertext form. However, if you provide access to or distribute copies of a Project Gutenberg™ work in a format other than “Plain Vanilla ASCII” or other format used in the official version posted on the official Project Gutenberg™ website (www.gutenberg.org), you must, at no additional cost, fee or expense to the user, provide a copy, a means of exporting a copy, or a means of obtaining a copy upon request, of the work in its original “Plain Vanilla ASCII” or other form. Any alternate format must include the full Project Gutenberg™ License as specified in paragraph 1.E.1.

1.E.7. Do not charge a fee for access to, viewing, displaying, performing, copying or distributing any Project Gutenberg™ works unless you comply with paragraph 1.E.8 or 1.E.9.

1.E.8. You may charge a reasonable fee for copies of or providing access to or distributing Project Gutenberg™ electronic works provided that:

- You pay a royalty fee of 20% of the gross profits you derive from the use of Project Gutenberg™ works calculated using the method you already use to calculate your applicable taxes. The fee is owed to the owner of the Project Gutenberg™ trademark, but he has agreed to donate royalties under this paragraph to the Project Gutenberg Literary Archive Foundation. Royalty payments must be paid within 60 days following each date on which you prepare (or are legally required to prepare) your periodic tax returns. Royalty payments should be clearly marked as such and sent to the Project Gutenberg Literary Archive Foundation at the address specified in Section 4, “Information about donations to the Project Gutenberg Literary Archive Foundation.”
- You provide a full refund of any money paid by a user who notifies you in writing (or by e-mail) within 30 days of receipt that s/he does not agree to the terms of the full Project Gutenberg™ License. You must require such a user to return or destroy all copies of the works possessed in a physical medium and discontinue all use of and all access to other copies of Project Gutenberg™ works.
- You provide, in accordance with paragraph 1.F.3, a full refund of any money paid for a work or a replacement copy, if a defect in the electronic work is discovered and reported to you within 90 days of receipt of the work.
- You comply with all other terms of this agreement for free distribution of Project Gutenberg™ works.

1.E.9. If you wish to charge a fee or distribute a Project Gutenberg™ electronic work or group of works on different terms than are set forth in this agreement, you must obtain permission in writing from the Project Gutenberg Literary Archive Foundation, the manager of the Project Gutenberg™ trademark. Contact the Foundation as set forth in Section 3 below.

1.F.

1.F.1. Project Gutenberg volunteers and employees expend considerable effort to identify, do copyright research on, transcribe and proofread works not protected by U.S. copyright law in creating the Project Gutenberg™ collection. Despite these efforts, Project Gutenberg™ electronic works, and the medium on which they may be stored, may contain “Defects,” such as, but not limited to, incomplete, inaccurate or corrupt data, transcription errors, a copyright or other intellectual property infringement, a defective or damaged disk or other medium, a computer virus, or computer codes that damage or cannot be read by your equipment.

1.F.2. LIMITED WARRANTY, DISCLAIMER OF DAMAGES - Except for the “Right of Replacement or Refund” described in paragraph 1.F.3, the Project Gutenberg Literary Archive Foundation, the owner of the Project Gutenberg™ trademark, and any other party distributing a Project Gutenberg™ electronic work under this agreement, disclaim all liability to you for damages, costs and expenses, including legal fees. YOU AGREE THAT YOU HAVE NO REMEDIES FOR NEGLIGENCE, STRICT LIABILITY, BREACH OF WARRANTY OR BREACH OF CONTRACT EXCEPT THOSE PROVIDED IN PARAGRAPH 1.F.3. YOU AGREE THAT THE FOUNDATION, THE TRADEMARK OWNER, AND ANY DISTRIBUTOR UNDER THIS AGREEMENT WILL NOT BE LIABLE TO YOU FOR ACTUAL, DIRECT, INDIRECT, CONSEQUENTIAL, PUNITIVE OR INCIDENTAL DAMAGES EVEN IF YOU GIVE NOTICE OF THE POSSIBILITY OF SUCH DAMAGE.

1.F.3. LIMITED RIGHT OF REPLACEMENT OR REFUND - If you discover a defect in this electronic work within 90 days of receiving it, you can receive a refund of the money (if any) you paid for it by sending a written explanation to the person you received the work from. If you received the work on a physical medium, you must return the medium with your written explanation. The person or entity that provided you with the defective work may elect to provide a replacement copy in lieu of a refund. If you received the work electronically, the person or entity providing it to you may choose to give you a second opportunity to receive the work electronically in lieu of a refund. If the second copy is also defective, you may demand a refund in writing without further opportunities to fix the problem.

1.F.4. Except for the limited right of replacement or refund set forth in paragraph 1.F.3, this work is provided to you 'AS-IS', WITH NO OTHER WARRANTIES OF ANY KIND, EXPRESS OR IMPLIED, INCLUDING BUT NOT LIMITED TO WARRANTIES OF MERCHANTABILITY OR FITNESS FOR ANY PURPOSE.

1.F.5. Some states do not allow disclaimers of certain implied warranties or the exclusion or limitation of certain types of damages. If any disclaimer or limitation set forth in this agreement violates the law of the state applicable to this agreement, the agreement shall be interpreted to make the maximum disclaimer or limitation permitted by the applicable state law. The invalidity or unenforceability of any provision of this agreement shall not void the remaining provisions.

1.F.6. INDEMNITY - You agree to indemnify and hold the Foundation, the trademark owner, any agent or employee of the Foundation, anyone providing copies of Project Gutenberg™ electronic works in accordance with this agreement, and any volunteers associated with the production, promotion and distribution of Project Gutenberg™ electronic works, harmless from all liability, costs and expenses, including legal fees, that arise directly or indirectly from any of the following which you do or cause to occur: (a) distribution of this or any Project Gutenberg™ work, (b) alteration, modification, or additions or deletions to any Project Gutenberg™ work, and (c) any Defect you cause.

Section 2. Information about the Mission of Project Gutenberg™

Project Gutenberg™ is synonymous with the free distribution of electronic works in formats readable by the widest variety of computers including obsolete, old, middle-aged and new computers. It exists because of the efforts of hundreds of volunteers and donations from people in all walks of life.

Volunteers and financial support to provide volunteers with the assistance they need are critical to reaching Project Gutenberg™'s goals and ensuring that the Project Gutenberg™ collection will remain freely available for generations to come. In 2001, the Project Gutenberg Literary Archive Foundation was created to provide a secure and permanent future for Project Gutenberg™ and future generations. To learn more about the Project Gutenberg Literary Archive Foundation and how your efforts and donations can help, see Sections 3 and 4 and the Foundation information page at www.gutenberg.org.

Section 3. Information about the Project Gutenberg Literary Archive Foundation

The Project Gutenberg Literary Archive Foundation is a non-profit 501(c)(3) educational corporation organized under the laws of the state of Mississippi and granted tax exempt status by the Internal Revenue Service. The Foundation's EIN or federal tax identification number is 64-6221541. Contributions to the Project Gutenberg Literary Archive Foundation are tax deductible to the full extent permitted by U.S. federal laws and your state's laws.

The Foundation's business office is located at 809 North 1500 West, Salt Lake City, UT 84116, (801) 596-1887. Email contact links and up to date contact information can be found at the Foundation's website and official page at www.gutenberg.org/contact

Section 4. Information about Donations to the Project Gutenberg Literary Archive Foundation

Project Gutenberg™ depends upon and cannot survive without widespread public support and donations to carry out its mission of increasing the number of public domain and licensed works that can be freely distributed in machine-readable form accessible by the widest array of equipment including outdated equipment. Many small donations (\$1 to \$5,000) are particularly important to maintaining tax exempt status with the IRS.

The Foundation is committed to complying with the laws regulating charities and charitable donations in all 50 states of the United States. Compliance requirements are not uniform and it takes a considerable effort, much paperwork and many fees to meet and keep up with these requirements. We do not solicit donations in locations where we have not received written confirmation of compliance. To SEND DONATIONS or determine the status of compliance for any particular state visit www.gutenberg.org/donate.

While we cannot and do not solicit contributions from states where we have not met the solicitation requirements, we know of no prohibition against accepting unsolicited donations from donors in such states who approach us with offers to donate.

International donations are gratefully accepted, but we cannot make any statements concerning tax treatment of donations received from outside the United States. U.S. laws alone swamp our small staff.

Please check the Project Gutenberg web pages for current donation methods and addresses. Donations are accepted in a number of other ways including checks, online payments and credit card donations. To donate, please visit: www.gutenberg.org/donate

Section 5. General Information About Project Gutenberg™ electronic works

Professor Michael S. Hart was the originator of the Project Gutenberg™ concept of a library of electronic works that could be freely shared with anyone. For forty years, he produced and distributed Project Gutenberg™ eBooks with only a loose network of volunteer support.

Project Gutenberg™ eBooks are often created from several printed editions, all of which are confirmed as not protected by copyright in the U.S. unless a copyright notice is included. Thus, we do not necessarily keep eBooks in compliance with any particular paper edition.

Most people start at our website which has the main PG search facility: www.gutenberg.org.

This website includes information about Project Gutenberg™, including how to make donations to the Project Gutenberg Literary Archive Foundation, how to help produce our new eBooks, and how to subscribe to our email newsletter to hear about new eBooks.