

**The Project Gutenberg eBook of Letters on Natural Magic; Addressed to Sir
Walter Scott, Bart, by David Brewster**

This ebook is for the use of anyone anywhere in the United States and most other parts of the world at no cost and with almost no restrictions whatsoever. You may copy it, give it away or re-use it under the terms of the Project Gutenberg License included with this ebook or online at www.gutenberg.org. If you are not located in the United States, you'll have to check the laws of the country where you are located before using this eBook.

Title: Letters on Natural Magic; Addressed to Sir Walter Scott, Bart

Author: David Brewster

Release date: April 3, 2016 [EBook #51645]

Language: English

Credits: Produced by Susan Skinner, Les Galloway and the Online Distributed Proofreading Team at <http://www.pgdp.net> (This file was produced from images generously made available by The Internet Archive)

*** START OF THE PROJECT GUTENBERG EBOOK LETTERS ON NATURAL MAGIC;
ADDRESS TO SIR WALTER SCOTT, BART ***

LETTERS
ON
NATURAL MAGIC,
ADDRESSED TO
SIR WALTER SCOTT, BART.

BY
SIR DAVID BREWSTER, LL.D., F.R.S.

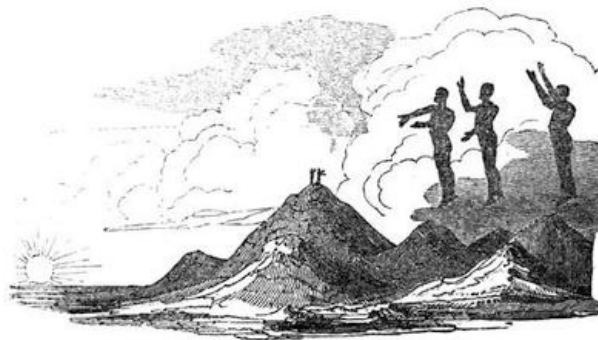

SEVENTH EDITION.

LONDON:
WILLIAM TEGG AND Co., 85, QUEEN STREET.
CHEAPSIDE.
1856.

CONTENTS.

LETTER I.

Extent and interest of the subject—Science employed by ancient governments to deceive and enslave their subjects—Influence of the supernatural upon ignorant minds—Means employed by the ancient magicians to establish their authority—Derived from a knowledge of the phenomena of Nature—From the influence of narcotic drugs upon the victims of their delusion—From every branch of science—Acoustics—Hydrostatics—Mechanics—Optics—M. Salvete's work on the occult sciences—Object of the following letters

Page 1

LETTER II.

The eye the most important of our organs—Popular description of it—The eye is the most fertile source of mental illusions—Disappearance of objects when their images fall upon the base of the optic nerve—Disappearance of objects when seen obliquely—Deceptions arising from viewing objects in a faint light—Luminous figures created by pressure on the eye, either from external causes or from the fulness of the blood-vessels—Ocular spectra or accidental colours—Remarkable effects produced by intense light—Influence of the imagination in viewing these spectra—Remarkable illusion produced by this affection of the eye—Duration of impressions of light on the eye—Thaumatrope—Improvements upon it suggested—Disappearance of halves of objects or of one of two persons—Insensibility of the eye to particular colours—Remarkable optical illusion described

8

LETTER III.

Subject of spectral illusions—Recent and interesting case of Mrs. A.—Her first illusion affecting the ear—Spectral apparition of her husband—Spectral apparition of a cat—Apparition of a near and living relation in grave-clothes, seen in a looking-glass—Other illusions, affecting the ear—Spectre of a deceased friend sitting in an easy-chair—Spectre of a coach-and-four filled with skeletons—Accuracy and value of the preceding cases—State of health under which they arose—Spectral apparitions are pictures on the retina—The ideas of memory and imagination are also pictures on the retina—General views of the subject—Approximate explanation of spectral apparitions

37

LETTER IV.

Science used as an instrument of imposture—Deceptions with plane and concave mirrors practised by the ancients—The magician's mirror—Effects of concave mirrors—Aërial images—Images on smoke—Combination of mirrors for producing pictures from living objects—The mysterious dagger—Ancient miracles with concave mirrors—Modern necromancy with them, as seen by Cellini—Description and effects of the magic lantern—Improvements upon it—Phantasmagoric exhibitions of Philipstall and others—Dr. Young's arrangement of lenses, &c., for the Phantasmagoria—Improvements suggested—Catadioptrical phantasmagoria for producing the pictures from living objects—Method of cutting off parts of the figures—Kircher's mysterious hand-writing on the wall—His hollow cylindrical mirror for aërial images—Cylindrical mirror for re-forming distorted pictures—Mirrors of variable curvature for producing caricatures

56

LETTER V.

Miscellaneous optical illusions—Conversions of cameos into intaglios, or elevations into depressions, and the reverse—Explanation of this class of deceptions—Singular effects of illumination with light of one simple colour—Lamps for producing homogeneous yellow light—Methods of increasing the effects of this exhibition—Method of reading the inscription of coins in the dark—Art of deciphering the effaced inscription of coins—Explanation of these singular effects—Apparent motion of the eyes in portraits—Remarkable examples of this—Apparent motion of the features of a portrait, when the eyes are made to move—Remarkable experiment of breathing light and darkness

98

LETTER VI.

Natural phenomena marked with the marvellous—Spectre of the Brocken described—Analogous phenomena—Aërial spectres seen in Cumberland—Fata Morgana in the Straits of Messina—Objects below the horizon raised and magnified by refraction—Singular example seen at Hastings—Dover Castle seen through the hill on which it stands—Erect and inverted images of distant ships seen in the air—Similar phenomena seen in the Arctic regions—Enchanted coast—Mr. Scoresby recognizes his father's ship by its aërial image—Images of cows seen in

the air—Inverted images of horses seen in South America—Lateral images produced by refraction—Aërial spectres by reflexion—Explanation of the preceding phenomena

127

LETTER VII.

Illusions depending on the ear—Practised by the ancients—Speaking and singing heads of the ancients—Exhibition of the Invisible Girl described and explained—Illusions arising from the difficulty of determining the direction of sounds—Singular example of this illusion—Nature of ventriloquism—Exhibitions of some of the most celebrated ventriloquists—M. St. Gille—Louis Brabant—M. Alexandre—Capt. Lyon's account of Esquimaux ventriloquists

157

LETTER VIII.

Musical and harmonic sounds explained—Power of breaking glasses with the voice—Musical sounds from the vibration of a column of air—and of solid bodies—Kaleidophone—Singular acoustic figures produced on sand laid on vibrating plates of glass—and on stretched membranes—Vibration of flat rulers and cylinders of glass—Production of silence from two sounds—Production of darkness from two lights—Explanation of these singular effects—Acoustic automaton—Droz's bleating sheep—Maillardet's singing-bird—Vaucanson's flute-player—His pipe and tabor-player—Baron Kempelen's talking-engine—Kratzenstein's speaking-machine—Mr. Willis's researches

179

LETTER IX.

Singular effects in nature depending on sound—Permanent character of speech—Influence of great elevations on the character of sounds, and on the powers of speech—Power of sound in throwing down buildings—Dog killed by sound—Sounds greatly changed under particular circumstances—Great audibility of sounds during the night explained—Sounds deadened in media of different densities—Illustrated in the case of a glass of champagne—and in that of new-fallen snow—Remarkable echoes—Reverberations of thunder—Subterranean noises—Remarkable one at the Solfaterra—Echo at the Menai suspension bridge—Temporary deafness produced in diving-bells—Inaudibility of particular sounds to particular ears—Vocal powers of the statue of Memnon—Sounds in granite rocks—Musical mountain of El-Nakous

212

LETTER X.

Mechanical inventions of the ancients few in number—Ancient and modern feats of strength—Feats of Eckeberg particularly described—General explanation of them—Real feats of strength performed by Thomas Topham—Remarkable power of lifting heavy persons when the lungs are inflated—Belzoni's feat of sustaining pyramids of men—Deception of walking along the ceiling in an inverted position—Pneumatic apparatus in the foot of the house-fly for enabling it to walk in opposition to gravity—Description of the analogous apparatus employed by the gecko lizard for the same purpose—Apparatus used by the *Echineis remora*, or sucking-fish

244

LETTER XI.

Mechanical automata of the ancients—Moving tripods—Automata of Dædalus—Wooden pigeon of Archytas—Automatic clock of Charlemagne—Automata made by Turrianus for Charles V.—Camus's automatic carriage made for Louis XIV.—Degenne's mechanical peacock—Vaucanson's duck which ate and digested its food—Du Moulin's automata—Baron Kempelen's automaton chess-player—Drawing and writing automata—Maillardet's conjurer—Benefits derived from the passion for automata—Examples of wonderful machinery for useful purposes—Duncan's tambouring machinery—Watt's statue-turning machinery—Babbage's calculating machinery

264

LETTER XII.

Wonders of chemistry—Origin, progress, and objects of alchemy—Art of breathing fire—Employed by Barchochebas, Eunus, &c.—Modern method—Art of walking upon burning coals and red-hot iron, and of plunging the hands in melted lead and boiling water—Singular property of boiling tar—Workmen plunge their hands in melted copper—Trial of ordeal by fire—Aldini's incombustible dresses—Examples of their wonderful power in resisting flame—Power of breathing and enduring air of high temperatures—Experiments made by Sir Joseph Banks, Sir Charles Blagden, and Mr. Chantrey

227

LETTER XIII.

Spontaneous combustion—In the absorption of air by powdered charcoal—and of hydrogen by spongy platinum—Dobereiner's lamp—Spontaneous combustion in the bowels of the earth—Burning cliffs—Burning soil—Combustion without flame—Spontaneous combustion of human beings—Countess Zangari—Grace Pett—Natural fire-temples of the Guebres—Spontaneous fires in the Caspian Sea—Springs of inflammable gas near Glasgow—Natural light-house of Maracaybo—New elastic fluids in the cavities—of gems—Chemical operations going on in their cavities—Explosions produced in them by heat—Remarkable changes of colour from chemical causes—Effects of the nitrous oxide or Paradise gas when breathed—Remarkable cases described—Conclusion

LETTERS

ON

NATURAL MAGIC;

ADDRESSED TO

SIR WALTER SCOTT, BART.

LETTER I.

Extent and interest of the subject—Science employed by ancient governments to deceive and enslave their subjects—Influence of the supernatural upon ignorant minds—Means employed by the ancient magicians to establish their authority—Derived from a knowledge of the phenomena of Nature—From the influence of narcotic drugs upon the victims of their delusion—From every branch of science—Acoustics—Hydrostatics—Mechanics—Optics—M. Salvette's work on the occult sciences—Object of the following letters.

MY DEAR SIR WALTER,

As it was at your suggestion that I undertook to draw up a popular account of those prodigies of the material world which have received the appellation of *Natural Magic*, I have availed myself of the privilege of introducing it under the shelter of your name. Although I cannot hope to produce a volume at all approaching in interest to that which you have contributed to the Family Library, yet the popular character of some of the topics which belong to this branch of Demonology may atone for the defects of the following Letters; and I shall deem it no slight honour if they shall be considered as forming an appropriate supplement to your valuable work.

The subject of Natural Magic is one of great extent as well as of deep interest. In its widest range, it embraces the history of the governments and the superstitions of ancient times,—of the means by which they maintained their influence over the human mind,—of the assistance which they derived from the arts and the sciences, and from a knowledge of the powers and phenomena of nature. When the tyrants of antiquity were unable or unwilling to found their sovereignty on the affections and interests of their people, they sought to entrench themselves in the strongholds of supernatural influence, and to rule with the delegated authority of Heaven. The prince, the priest, and the sage, were leagued in a dark conspiracy to deceive and enslave their species; and man, who refused his submission to a being like himself, became the obedient slave of a spiritual despotism, and willingly bound himself in chains when they seemed to have been forged by the gods.

This system of imposture was greatly favoured by the ignorance of these early ages. The human mind is at all times fond of the marvellous, and the credulity of the individual may be often measured by his own attachment to the truth. When knowledge was the property of only one caste, it was by no means difficult to employ it in the subjugation of the great mass of society. An acquaintance with the motions of the heavenly bodies, and the variations in the state of the atmosphere, enabled its possessor to predict astronomical and meteorological phenomena with a frequency and an accuracy which could not fail to invest him with a divine character. The power of bringing down fire from the heavens, even at times when the electric influence was itself in a state of repose, could be regarded only as a gift from heaven. The power of rendering the human body insensible to fire was an irresistible instrument of imposture; and in the combinations of chemistry, and the influence of drugs and soporific embrocations on the human frame, the ancient magicians found their most available resources.

The secret use which was thus made of scientific discoveries and of remarkable inventions, has no doubt prevented many of them from reaching the present times; but though we are very ill informed respecting the progress of the ancients in various departments of the physical sciences, yet we have sufficient evidence that almost every branch of knowledge had contributed its wonders to the magician's budget, and we may even obtain some insight into the scientific acquirements of former ages, by a diligent study of their fables and their miracles.

The science of *Acoustics* furnished the ancient sorcerers with some of their best deceptions. The imitation of thunder in their subterranean temples could not fail to indicate the presence of a supernatural agent. The golden virgins whose ravishing voices resounded through the temple of Delphos;—the stone from the river Pactolus, whose trumpet notes scared the robber from the treasure which it guarded;—the speaking head which uttered its oracular responses at Lesbos; and the vocal statue of Memnon, which began at the break of day to accost the rising sun,—were all deceptions derived from science, and from a diligent observation of the phenomena of nature.

The principles of *Hydrostatics* were equally available in the work of deception. The marvellous fountain which Pliny describes in the island of Andros as discharging wine for seven days, and water during the rest of the year;—the spring of oil which broke out in Rome to welcome the return of Augustus from the Sicilian war,—the three empty urns which filled themselves with wine at the annual feast of Bacchus in the city of Elis,—the glass tomb of Belus which was full of

oil, and which when once emptied by Xerxes could not again be filled,—the weeping-statues, and the perpetual lamps of the ancients,—were all the obvious effects of the equilibrium and pressure of fluids.

Although we have no direct evidence that the philosophers of antiquity were skilled in *Mechanics*, yet there are indications of their knowledge by no means equivocal in the erection of the Egyptian obelisks, and in the transportation of huge masses of stone, and their subsequent elevation to great heights in their temples. The powers which they employed, and the mechanism by which they operated, have been studiously concealed, but their existence may be inferred from results otherwise inexplicable; and the inference derives additional confirmation from the mechanical arrangements which seemed to have formed a part of their religious impostures. When, in some of the infamous mysteries of ancient Rome, the unfortunate victims were carried off by the gods, there is reason to believe that they were hurried away by the power of machinery; and when Apollonius, conducted by the Indian sages to the temple of their god, felt the earth rising and falling beneath his feet, like the agitated sea, he was no doubt placed upon a moving floor capable of imitating the heavings of the waves. The rapid descent of those who consulted the oracle in the cave of Trophonius,—the moving tripods which Apollonius saw in the Indian temples,—the walking statues at Antium, and in the temple of Hierapolis,—and the wooden pigeon of Archytas, are specimens of the mechanical resources of the ancient magic.

But of all the sciences *Optics* is the most fertile in marvellous expedients. The power of bringing the remotest objects within the very grasp of the observer, and of swelling into gigantic magnitude the almost invisible bodies of the material world, never fails to inspire with astonishment even those who understand the means by which these prodigies are accomplished. The ancients, indeed, were not acquainted with those combinations of lenses and mirrors which constitute the telescope and the microscope, but they must have been familiar with the property of lenses and mirrors to form erect and inverted images of objects. There is reason to think that they employed them to effect the apparition of their gods; and in some of the descriptions of the optical displays which hallowed their ancient temples, we recognize all the transformations of the modern phantasmagoria.

It would be an interesting pursuit to embody the information which history supplies respecting the fables and incantations of the ancient superstitions, and to show how far they can be explained by the scientific knowledge which then prevailed. This task has, to a certain extent, been performed by M. Eusebe Salverte, in a work on the occult sciences which has recently appeared; but notwithstanding the ingenuity and learning which it displays, the individual facts are too scanty to support the speculations of the author, and the descriptions are too meagre to satisfy the curiosity of the reader.¹

In the following letters I propose to take a wider range, and to enter into more minute and popular details. The principal phenomena of nature, and the leading combinations of arts, which bear the impress of a supernatural character, will pass under our review, and our attention will be particularly called to those singular illusions of sense, by which the most perfect organs either cease to perform their functions, or perform them faithlessly; and where the efforts and the creations of the mind predominate over the direct perceptions of external nature.

In executing this plan, the task of selection is rendered extremely difficult by the superabundance of materials, as well as from the variety of judgments for which these materials must be prepared. Modern science may be regarded as one vast miracle, whether we view it in relation to the Almighty Being by whom its objects and its laws were formed, or to the feeble intellect of man, by which its depths have been sounded, and its mysteries explored; and if the philosopher who is familiarized with its wonders, and who has studied them as necessary results of general laws, never ceases to admire and adore their Author, how great should be their effect upon less gifted minds, who must ever view them in the light of inexplicable prodigies!—Man has in all ages sought for a sign from heaven, and yet he has been habitually blind to the millions of wonders with which he is surrounded. If the following pages should contribute to abate this deplorable indifference to all that is grand and sublime in the universe, and if they should inspire the reader with a portion of that enthusiasm of love and gratitude which can alone prepare the mind for its final triumph, the labours of the author will not have been wholly fruitless.

LETTER II.

The eye the most important of our organs—Popular description of it—The eye is the most fertile source of mental illusions—Disappearance of objects when their images fall upon the base of the optic nerve—Disappearance of objects when seen obliquely—Deceptions arising from viewing objects in a faint light—Luminous figures created by pressure on the eye, either from external causes or from the fulness of the blood-vessels—Ocular spectra or accidental colours—Remarkable effects produced by intense light—Influence of the imagination in viewing these spectra—Remarkable illusion produced by this affection of the eye—Duration of impressions of light on the eye—Thaumatrope—Improvements upon it suggested—Disappearance of halves of objects or of one of two persons—Insensibility of the eye to particular colours—Remarkable optical illusion described.

Of all the organs by which we acquire a knowledge of external nature, the eye is the most remarkable and the most important. By our other senses the information we obtain is comparatively limited. The touch and the taste extend no farther than the surface of our own bodies. The sense of smell is exercised within a very narrow sphere, and that of recognizing sounds is limited to the distance at which we hear the bursting of a meteor and the crash of a thunderbolt. But the eye enjoys a boundless range of observation. It takes cognizance not only of other worlds belonging to the solar system, but of other systems of worlds infinitely removed into the immensity of space; and when aided by the telescope, the invention of human wisdom, it is able to discover the forms, the phenomena, and the movements of bodies whose distance is as inexpressible in language as it is inconceivable in thought.

While the human eye has been admired by ordinary observers for the beauty of its form, the power of its movements, and the variety of its expression, it has excited the wonder of philosophers by the exquisite mechanism of its interior, and its singular adaptation to the variety of purposes which it has to serve. The eyeball is nearly globular, and is about an inch in diameter. It is formed externally by a tough opaque membrane called the *sclerotic coat*, which forms the white of the eye, with the exception of a small circular portion in front called the *cornea*. This portion is perfectly transparent, and so tough in its nature as to afford a powerful resistance to external injury. Immediately within the cornea, and in contact with it, is the *aqueous humour*, a clear fluid, which occupies only a small part of the front of the eye. Within this humour is the iris, a circular membrane, with a hole in its centre called the *pupil*. The colour of the eye resides in this membrane, which has the curious property of contracting and expanding so as to diminish or enlarge the pupil,—an effect which human ingenuity has not been able even to imitate. Behind the iris is suspended the *crystalline lens*, in a fine transparent capsule or bag of the same form with itself. It is then succeeded by the *vitreous humour*, which resembles the transparent white of an egg, and fills up the rest of the eye. Behind the vitreous humour, there is spread out on the inside of the eyeball a fine delicate membrane, called the *retina*, which is an expansion of the *optic nerve*, entering the back of the eye and communicating with the brain.

A perspective view and horizontal section of the left eye, shown in the annexed figure, will convey a popular idea of its structure. It is, as it were, a small camera obscura, by means of which the pictures of external objects are painted on the retina, and, in a way of which we are ignorant, it conveys the impression of them to the brain.

Fig. 1.



This wonderful organ may be considered as the sentinel which guards the pass between the worlds of matter and of spirit, and through which all their communications are interchanged. The optic nerve is the channel by which the mind peruses the hand-writing of Nature on the retina, and through which it transfers to that material tablet its decisions and its creations. The eye is consequently the principal seat of the supernatural. When the indications of the marvellous are addressed to us through the ear, the mind may be startled without being deceived, and reason may succeed in suggesting some probable source of the illusion by which we have been alarmed: but when the eye in solitude sees before it the forms of life, fresh in their colours and vivid in their outline; when distant or departed friends are suddenly presented to its view; when visible bodies disappear and reappear without any intelligible cause; and when it beholds objects, whether real or imaginary, for whose presence no cause can be assigned, the conviction of supernatural agency becomes, under ordinary circumstances, unavoidable.

Hence it is not only an amusing but a useful occupation to acquire a knowledge of those causes which are capable of producing so strange a belief, whether it arises from the delusions which the mind practises upon itself, or from the dexterity and science of others. I shall therefore proceed to explain those illusions which have their origin in the eye, whether they are general, or only occasionally exhibited in particular persons, and under particular circumstances.

There are few persons aware that when they look with one eye, there is some particular object before them to which they are absolutely blind. If we look with the right eye, this point is always about 15° to the right of the object which we are viewing, or to the right of the axis of the eye or the point of most distinct vision. If we look with the left eye, the point is as far to the left. In order to be convinced of this curious fact, which was discovered by M. Mariotte, place two coloured wafers upon a sheet of white paper at the distance of three inches, and look at the left-hand wafer with the right eye at the distance of about 11 or 12 inches, taking care to keep the eye straight above the wafer, and the line which joins the eyes parallel to the line which joins the wafers. When this is done, and the left eye closed, the right-hand wafer will no longer be visible. The same effect will be produced if we close the right eye and look with the left eye at the right-hand wafer. When we examine the retina to discover to what part of it this insensibility to light belongs, we find that the image of the invisible wafer has fallen on the base of the optic nerve, or the place where this nerve enters the eye and expands itself to form the retina. This point is shown in the preceding figure by a convexity at the place where the nerve enters the eye.

But though light of ordinary intensity makes no impression upon this part of the eye, a very strong light does, and even when we use candles or highly luminous bodies in place of wafers, the body does not wholly disappear, but leaves behind a faint cloudy light, without, however, giving anything like an image of the object from which the light proceeds.

When the objects are *white* wafers upon a *black* ground, the white wafer absolutely disappears, and the space which it covers appears to be completely black; and as the light which illuminates a landscape is not much different from that of a white wafer, we should expect, whether we use one or both eyes,² to see a black or a dark spot upon every landscape, within 15° of the point which most particularly attracts our notice. The Divine Artificer, however, has not left his work thus imperfect. Though the base of the optic nerve is insensible to light that falls directly upon it, yet it has been made susceptible of receiving luminous impressions from the parts which surround it; and the consequence of this is, that when the wafer disappears, the spot which is occupied, in place of being black, has always the same colour as the ground upon which the wafer is laid, being white when the wafer is placed upon a white ground, and red when it is placed upon a red ground. This curious effect may be rudely illustrated by comparing the retina to a sheet of blotting-paper, and the base of the optic nerve to a circular portion of it covered with a piece of sponge. If a shower falls upon the paper, the protected part will not be wetted by the rain which falls upon the sponge that covers it, but in a few seconds it will be as effectually wetted by the moisture which it absorbs from the wet paper with which it is surrounded. In like manner the insensible spot on the retina is stimulated by a borrowed light, and the apparent defect is so completely removed, that its existence can be determined only by the experiment already described.

Of the same character, but far more general in its effects, and important in its consequences, is another illusion of the eye which presented itself to me several years ago. When the eye is steadily occupied in viewing any particular object, or when it takes a fixed direction while the mind is occupied with any engrossing topic of speculation or of grief, it suddenly loses sight of, or becomes blind to, objects seen indirectly, or upon which it is not fully directed. This takes place whether we use one or both eyes, and the object which disappears will reappear without any change in the position of the eye, while other objects will vanish and revive in succession without any apparent cause. If a sportsman, for example, is watching with intense interest the motions of one of his dogs, his companion, though seen with perfect clearness by indirect vision, will vanish, and the light of the heath or of the sky will close in upon the spot which he occupied.

In order to witness this illusion, put a little bit of white paper on a green cloth, and, within three or four inches of it, place a narrow strip of white paper. At the distance of twelve or eighteen inches, fix one eye steadily upon the little bit of white paper, and in a short time a part or even the whole of the strip of paper will vanish as if it had been removed from the green cloth. It will again reappear, and again vanish, the effect depending greatly on the steadiness with which the eye is kept fixed. This illusion takes place when both the eyes are open, though it is easier to observe it when one of them is closed. The same thing happens when the object is luminous. When a candle is thus seen by indirect vision, it never wholly disappears, but it spreads itself out into a cloudy mass, the centre of which is blue, encircled with a bright ring of yellow light.

This inability of the eye to preserve a sustained vision of objects seen obliquely, is curiously compensated by the greater sensibility of those parts of the eye that have this defect. The eye has the power of seeing objects with perfect distinctness only when it is directed straight upon them; that is, all objects seen indirectly are seen indistinctly: but it is a curious circumstance, that when we wish to obtain a sight of a very faint star, such as one of the satellites of Saturn, we can see it most distinctly *by looking away from it*, and when the eye is turned full upon it it immediately disappears.

Effects still more remarkable are produced in the eye when it views objects that are difficult to be seen from the small degree of light with which they happen to be illuminated. The imperfect view which we obtain of such objects forces us to fix the eye more steadily upon them; but the

more exertion we make to ascertain what they are, the greater difficulties do we encounter to accomplish our object. The eye is actually thrown into a state of the most painful agitation, the object will swell and contract, and partly disappear, and it will again become visible when the eye has recovered from the delirium into which it has been thrown. This phenomenon may be most distinctly seen when the objects in a room are illuminated with the feeble gleam of a fire almost extinguished; but it may be observed in daylight by the sportsman when he endeavours to mark upon the monotonous heath the particular spot where moor-game has alighted. Availing himself of the slightest difference of tint in the adjacent heath, he keeps his eye steadily fixed on it as he advances, but whenever the contrast of illumination is feeble, he will invariably lose sight of his mark, and if the retina is capable of taking it up, it is only to lose it a second time.

This illusion is likely to be most efficacious in the dark, when there is just sufficient light to render white objects faintly visible, and to persons who are either timid or credulous must prove a frequent source of alarm. Its influence, too, is greatly aided by another condition of the eye, into which it is thrown during partial darkness. The pupil expands nearly to the whole width of the iris, in order to collect the feeble light which prevails; but it is demonstrable that in this state the eye cannot accommodate itself to see near objects distinctly, so that the forms of persons and things actually become more shadowy and confused when they come within the very distance at which we count upon obtaining the best view of them. These affections of the eye are, we are persuaded, very frequent causes of a particular class of apparitions which are seen at night by the young and the ignorant. The spectres which are conjured up are always *white*, because no other colour can be seen, and they are either formed out of inanimate objects which reflect more light than others around them, or of animals or human beings whose colour or change of place renders them more visible in the dark. When the eye dimly descries an inanimate object whose different parts reflect different degrees of light, its brighter parts may enable the spectator to keep up a continued view of it; but the disappearance and reappearance of its fainter parts, and the change of shape which ensues, will necessarily give it the semblance of a living form, and if it occupies a position which is unapproachable, and where animate objects cannot find their way, the mind will soon transfer to it a supernatural existence. In like manner a human figure shadowed forth in a feeble twilight may undergo similar changes, and after being distinctly seen while it is in a situation favourable for receiving and reflecting light, it may suddenly disappear in a position fully before, and within the reach of, the observer's eye; and if this evanescence takes place in a path or road where there was no side-way by which the figure could escape, it is not easy for an ordinary mind to efface the impression which it cannot fail to receive. Under such circumstances we never think of distrusting an organ which we have never found to deceive us; and the truth of the maxim that "seeing is believing" is too universally admitted, and too deeply rooted in our nature, to admit on any occasion of a single exception.

In these observations we have supposed that the spectator bears along with him no fears or prejudices, and is a faithful interpreter of the phenomena presented to his senses; but if he is himself a believer in apparitions, and unwilling to receive an ocular demonstration of their reality, it is not difficult to conceive the picture which will be drawn when external objects are distorted and caricatured by the imperfect indications of his senses, and coloured with all the vivid hues of the imagination.

Another class of ocular deceptions have their origin in a property of the eye which has been very imperfectly examined. The fine nervous fabric which constitutes the retina, and which extends to the brain, has the singular property of being *phosphorescent by pressure*. When we press the eyeball outwards by applying the point of the finger between it and the nose, a circle of light will be seen, which Sir Isaac Newton describes as "a circle of colours like those in the feather of a peacock's tail." He adds, that "if the eye and the figure remain quiet, these colours vanish in a second of time; but if the finger be moved with a quavering motion, they appear again." In the numerous observations which I have made on these luminous circles, I have never been able to observe any colour but white, with the exception of a general red tinge which is seen when the eyelids are closed, and which is produced by the light which passes through them. The luminous circles, too, always continue while the pressure is applied, and they may be produced as readily after the eye has been long in darkness as when it has been recently exposed to light. When the pressure is very gently applied, so as to compress the fine pulpy substance of the retina, light is immediately created when the eye is in total darkness; and when in this state light is allowed to fall upon it, the part compressed is more sensible to light than any other part, and consequently appears more luminous. If we increase the pressure, the eyeball, being filled with incompressible fluids, will protrude all round the point of pressure, and consequently the retina at the protruded part will be *compressed* by the outward pressure of the contained fluid, while the retina on each side, namely, under the point of pressure and beyond the protruded part, will be drawn towards the protruded part or *dilated*. Hence the part under the finger which was originally compressed is now *dilated*, the adjacent parts *compressed*, and the more remote parts immediately without this *dilated* also. Now we have observed, that when the eye is, under these circumstances, exposed to light, there is a bright luminous circle shading off externally and internally into total darkness. We are led, therefore, to the important conclusions, that when the retina is compressed in total darkness it gives out light; that when it is compressed when exposed to light, its sensibility to light is increased; and that when it is *dilated under exposure to light, it becomes absolutely blind, or insensible to all luminous impressions*.

When the body is in a state of perfect health, this phosphorescence of the eye shows itself on many occasions. When the eye or the head receives a sudden blow, a bright flash of light shoots from the eyeball. In the act of sneezing, gleams of light are emitted from each eye both during

the inhalation of the air, and during its subsequent protrusion, and in blowing air violently through the nostrils, two patches of light appear above the axis of the eye and in front of it, while other two luminous spots unite into one, and appear as it were about the point of the nose when the eyes are directed to it. When we turn the eyeball by the action of its own muscles, the retina is affected at the place where the muscles are inserted, and there may be seen opposite each eye, and towards the nose, two semicircles of light, and other two extremely faint towards the temples. At particular times, when the retina is more phosphorescent than at others, these semicircles are expanded into complete circles of light.

In a state of indisposition, the phosphorescence of the retina appears in new and more alarming forms. When the stomach is under a temporary derangement accompanied with headache, the pressure of the blood-vessels upon the retina shows itself, in total darkness, by a faint blue light floating before the eye, varying in its shape, and passing away at one side. This blue light increases in intensity, becomes *green* and then *yellow*, and sometimes rises to *red*, all these colours being frequently seen at once, or the mass of light shades off into darkness. When we consider the variety of distinct forms which in a state of perfect health the imagination can conjure up when looking into a burning fire, or upon an irregularly shaded surface,³ it is easy to conceive how the masses of coloured light which float before the eye may be moulded by the same power into those fantastic and natural shapes, which so often haunt the couch of the invalid, even when the mind retains its energy, and is conscious of the illusion under which it labours. In other cases, temporary blindness is produced by pressure upon the optic nerve, or upon the retina; and under the excitation of fever or delirium, when the physical cause which produces spectral forms is at its height, there is superadded a powerful influence of the mind, which imparts a new character to the phantasms of the senses.

In order to complete the history of the illusions which originate in the eye, it will be necessary to give some account of the phenomena called *ocular spectra*, or *accidental colours*. If we cut a figure out of red paper, and, placing it on a sheet of white paper, view it steadily for some seconds with one or both eyes fixed on a particular part of it, we shall observe the red colour to become less brilliant. If we then turn the eye from the red figure upon the white paper, we shall see a distinct *green* figure, which is the *spectrum*, or accidental colour of the *red* figure. With differently coloured figures we shall observe differently coloured spectra, as in the following table:—

COLOUR OF THE ORIGINAL FIGURES.	COLOUR OF THE SPECTRAL FIGURES.
Red,	Bluish-green.
Orange,	Blue.
Yellow,	Indigo.
Green,	Reddish-violet.
Blue,	Orange-red.
Indigo,	Orange-yellow.
Violet,	Yellow.
White,	Black.
Black,	White.

The two last of these experiments, viz., white and black figures, may be satisfactorily made by using a white medallion on a dark ground, and a black profile figure. The spectrum of the former will be found to be black, and that of the latter white.

These ocular spectra often show themselves without any effort on our part, and even without our knowledge. In a highly painted room, illuminated by the sun, those parts of the furniture on which the sun does not directly fall have always the opposite or accidental colour. If the sun shines through a chink in a *red* window-curtain, its light will appear *green*, varying as in the above table, with the colour of the curtain; and if we look at the image of a candle, reflected from the water in a *blue* finger-glass, it will appear *yellow*. Whenever, in short, the eye is affected with one prevailing colour, it sees at the same time the spectral or accidental colour, just as when a musical string is vibrating, the ear hears at the same time its fundamental and its harmonic sounds.

If the prevailing light is *white* and *very strong*, the spectra which it produces are no longer black, but of various colours in succession. If we look at the sun, for example, when near the horizon, or when reflected from glass or water so as to moderate its brilliancy, and keep the eye upon it steadily for a few seconds, we shall see, even for hours afterwards, and whether the eyes are open or shut, a spectrum of the sun varying in its colours. At first, with the eye open, it is *brownish-red* with a *sky-blue* border, and when the eye is shut, it is *green* with a *red* border. The *red* becomes more brilliant, and the *blue* more vivid, till the impression is gradually worn off; but even when they become very faint, they may be revived by a gentle pressure on the eyeball.

Some eyes are more susceptible than others of these spectral impressions, and Mr. Boyle mentions an individual who continued for years to see the spectre of the sun when he looked upon bright objects. This fact appeared to Locke so interesting and inexplicable, that he consulted Sir Isaac Newton respecting its cause, and drew from him the following interesting account of a similar effect upon himself:—"The observation you mention in Mr. Boyle's book of colours, I once made upon myself with the hazard of my eyes. The manner was this: I looked a

very little while upon the sun in the looking-glass with my right eye, and then turned my eyes into a dark corner of my chamber, and winked, to observe the impression made, and the circles of colours which encompassed it, and how they decayed by degrees, and at last vanished. This I repeated a second and a third time. At the third time, when the phantasm of light and colours about it were almost vanished, intending my fancy upon them to see their last appearance, I found, to my amazement, that they began to return, and by little and little to become as lively and vivid as when I had newly looked upon the sun. But when I ceased to intend my face upon them, they vanished again. After this I found that as often as I went into the dark, and intended my mind upon them, as when a man looks earnestly to see anything which is difficult to be seen, I could make the phantasm return without looking any more upon the sun; and the oftener I made it return, the more easily I could make it return again. And at length, by repeating this without looking any more upon the sun, I made such an impression on my eye, that, if I looked upon the clouds, or a book, or any bright object, I saw upon it a round bright spot of light like the sun, and, which is still stranger, though I looked upon the sun with my right eye only, and not with my left, yet my fancy began to make an impression upon my left eye as well as upon my right. For if I shut my right eye, and looked upon a book or the clouds with my left eye, I could see the spectrum of the sun almost as plain as with my right eye, if I did but intend my fancy a little while upon it: for at first, if I shut my right eye, and looked with my left, the spectrum of the sun did not appear till I intended my fancy upon it; but by repeating, this appeared every time more easily. And now in a few hours' time I had brought my eyes to such a pass, that I could look upon no bright object with either eye but I saw the sun before me, so that I durst neither write nor read; but to recover the use of my eyes, shut myself up in my chamber, made dark, for three days together, and used all means in my power to direct my imagination from the sun. For if I thought upon him, I presently saw his picture, though I was in the dark. But by keeping in the dark; and employing my mind about other things, I began, in three or four days, to have more use of my eyes again; and by forbearing to look upon bright objects, recovered them pretty well; though not so well but that, for some months after, the spectrums of the sun began to return as often as I began to meditate upon the phenomena, even though I lay in bed at midnight with my curtains drawn. But now I have been well for many years, though I am apt to think, if I durst venture my eyes, I could still make the phantasm return by the power of my fancy. This story I tell you, to let you understand, that in the observation related by Mr. Boyle, the man's fancy probably concurred with the impression made by the sun's light to produce that phantasm of the sun which he constantly saw in bright objects."⁴

I am not aware of any effects that had the character of supernatural having been actually produced by the causes above described; but it is obvious, that if a living figure had been projected against the strong light which imprinted these durable spectra of the sun, which might really happen when the solar rays are reflected from water, and diffused by its ruffled surface, this figure would have necessarily accompanied all the luminous spectres which the fancy created. Even in ordinary lights, strange appearances may be produced by even transient impressions; and if I am not greatly mistaken, the case which I am about to mention is not only one which may occur, but which actually happened. A figure dressed in *black*, and mounted upon a *white* horse, was riding along, exposed to the bright rays of the sun, which, through a small opening in the clouds, was throwing its light only upon that part of the landscape. The *black* figure was projected against a white cloud, and the white horse shone with particular brilliancy by its contrast with the dark soil against which it was seen. A person interested in the arrival of such a stranger had been for some time following his movements with intense anxiety, but, upon his disappearance behind a wood, was surprised to observe the spectre of the mounted stranger in the form of a *white* rider upon a *black* steed, and this spectre was seen for some time in the sky, or upon any pale ground to which the eye was directed. Such an occurrence, especially if accompanied with a suitable combination of events, might, even in modern times, have formed a chapter in the history of the marvellous.

It is a curious circumstance, that when the image of an object is impressed upon the retina only for a few moments, the picture which is left is exactly of the same colour with the object. If we look, for example, at a window at some distance from the eye, and then transfer the eye quickly to the wall, we shall see it distinctly, but momentarily, with *light* panes and *dark* bars; but in a space of time incalculably short, this picture is succeeded by the spectral impression of the window, which will consist of *black* panes and *white* bars. The similar spectrum, or that of the same colour as the object, is finely seen in the experiment of forming luminous circles by whirling round a burning stick, in which case the circles are always red.

In virtue of this property of the eye, an object may be seen in many places at once; and we may even exhibit at the same instant the two opposite sides of the same object, or two pictures painted on the opposite sides of a piece of card. It was found by a French philosopher, M. D'Arcet, that the impression of light continued on the retina about the eighth part of a second after the luminous body was withdrawn, and upon this principle Dr. Paris has constructed the pretty little instrument called the *Thaumatrope*, or the *Wonder-turner*. It consists of a number of circular pieces of card, about two or three inches broad, which may be twirled round with great velocity by the application of the fore-finger and thumb of each hand to pieces of silk string attached to opposite points of their circumference. On each side of the circular piece of card is painted part of a picture, or a part of a figure, in such a manner that the two parts would form a group or a whole figure, if we could see both sides at once. Harlequin, for example, is painted on one side, and Columbine on the other, so that by twirling round the card the two are seen at the same time in their usual mode of combination. The body of a Turk is drawn on one side, and his

head on the reverse, and by the rotation of the card the head is replaced upon his shoulders. The principle of this illusion may be extended to many other contrivances. Part of a sentence may be written on one side of a card, and the rest on the reverse. Particular letters may be given on one side, and others upon the other, or even halves or parts of each letter may be put upon each side, or all these contrivances may be combined, so that the sentiment which they express can be understood only when all the scattered parts are united by the revolution of the card.

As the revolving card is virtually transparent, so that bodies beyond it can be seen through it, the power of the illusion might be greatly extended by introducing into the picture other figures, either animate or inanimate. The setting sun, for example, might be introduced into a landscape; part of the flame of a fire might be seen to issue from the crater of a volcano, and cattle grazing in a field might make part of the revolutionary landscape. For such purposes, however, the form of the instrument would require to be completely changed, and the rotation should be effected round a standing axis by wheels and pinions, and a screen placed in front of the revolving plane with open compartments or apertures, through which the principal figures would appear. Had the principle of this instrument been known to the ancients, it would doubtless have formed a powerful engine of delusion in their temples, and might have been more effective than the optical means which they seem to have employed for producing the apparitions of their gods.

In certain diseased conditions of the eye, effects of a very remarkable kind are produced. The faculty of seeing objects double is too common to be noticed as remarkable; and though it may take place with only one eye, yet, as it generally arises from a transient inability to direct the axis of both eyes to the same point, it excites little notice. That state of the eye, however, in which we lose sight of half of every object at which we look, is more alarming and more likely to be ascribed to the disappearance of part of the object than to a defect of sight. Dr. Wollaston, who experienced this defect twice, informs us that, after taking violent exercise, he "suddenly found that he could see but half of a man whom he met, and that on attempting to read the name of JOHNSON over a door, he saw only SON, the commencement of the name being wholly obliterated from his view." In this instance, the part of the object which disappeared was towards his left; but on a second occurrence of the same affection, the part which disappeared was towards his right. There are many occasions on which this defect of the eye might alarm the person who witnessed it for the first time. At certain distances from the eye one of two persons would necessarily disappear; and by a slight change of position either in the observer or the person observed, the person that vanished would reappear, while the other would disappear in his turn. The circumstances under which these evanescences would take place could not be supposed to occur to an ordinary observer, even if he should be aware that the cause had its origin in himself. When a phenomenon so strange is seen by a person in perfect health, as it generally is, and who has never had occasion to distrust the testimony of his senses, he can scarcely refer it to any other cause than a supernatural one.

Among the affections of the eye which not only deceive the person who is subject to them, but those also who witness their operation, may be enumerated the insensibility of the eye to particular colours. This defect is not accompanied with any imperfection of vision, or connected with any disease either of a local or a general nature, and it has hitherto been observed in persons who possess a strong and a sharp sight. Mr. Huddart has described the case of one Harris, a shoemaker at Maryport in Cumberland, who was subject to this defect in a very remarkable degree. He seems to have been insensible to every colour, and to have been capable of recognizing only the two opposite tints of *black* and *white*. "His first suspicion of this defect arose when he was about four years old. Having by accident found in the street a child's stocking, he carried it to a neighbouring house to inquire for the owner. He observed the people call it a *red stocking*, though he did not understand why they gave it that denomination, as he himself thought it completely described by being called a stocking. The circumstance, however, remained in his memory, and, with other subsequent observations, led him to the knowledge of his defect. He observed also, that when young, other children could discern cherries on a tree by some pretended difference of colour, though he could only distinguish them from the leaves by their difference of size and shape. He observed also, that by means of this difference of colour, they could see the cherries at a greater distance than he could, though he could see other objects at as great a distance as they, that is, where the sight was not assisted by the colour." Harris had two brothers, whose perception of colours was nearly as defective as his own. One of these, whom Mr. Huddart examined, constantly mistook *light green* for *yellow*, and *orange* for *grass green*.

Mr. Scott has described, in the *Philosophical Transactions*, his own defect in perceiving colours. He states that he does not know any *green* in the world; that a *pink* colour and a *pale blue* are perfectly alike; that he has often thought a *full red* and a *full green* a good match; that he is sometimes baffled in distinguishing a *full purple* from a *deep blue*, but that he knows light, dark, and middle *yellows*, and all degrees of *blue* except *sky-blue*. "I married my daughter to a genteel, worthy man, a few years ago; the day before the marriage, he came to my house dressed in a new suit of fine cloth clothes. I was much displeased that he should come, as I supposed, in *black*, and said that he should go back to change his colour. But my daughter said, No, no; the colour is very genteel; that it was my eyes that deceived me. He was a gentleman of the law, in a fine, rich, claret-coloured dress, which is as much black to my eyes as any black that ever was dyed." Mr. Scott's father, his maternal uncle, one of his sisters, and her two sons, had all the same imperfection. Dr. Nichol has recorded a case where a naval officer purchased a *blue* uniform coat and waistcoat with *red* breeches to match the blue, and Mr. Harvey describes the case of a tailor at Plymouth, who on one occasion repaired an article of dress with *crimson* in place of *black* silk,

and on another patched the elbow of a *blue* coat with a piece of *crimson* cloth. It deserves to be remarked that our celebrated countrymen, the late Mr. Dugald Stewart, Mr. Dalton, and Mr. Troughton, have a similar difficulty in distinguishing colours. Mr. Stewart discovered this defect when one of his family was admiring the beauty of a Siberian crab-apple, which he could not distinguish from the leaves but by its form and size. Mr. Dalton cannot distinguish *blue* from pink, and the solar spectrum consists only of two colours, *yellow* and *blue*. Mr. Troughton regards *red ruddy pinks*, and brilliant *oranges*, as *yellows*, and *greens* as *blues*, so that he is capable only of appreciating *blue* and *yellow* colours.

In all those cases which have been carefully studied, at least in three of them, in which I have had the advantage of making personal observations, namely, those of Mr. Troughton, Mr. Dalton, and Mr. Liston, the eye is capable of seeing the whole of the prismatic spectrum, the red space appearing to be yellow. If the red space consisted of homogeneous or simple red rays, we should be led to infer that the eyes in question were not insensible to red light, but were merely incapable of discriminating between the impressions of red and yellow light. I have lately shown, however, that the prismatic spectrum consists of three equal and coincident spectra of *red*, *yellow*, and *blue* light, and consequently, that much yellow and a small portion of blue light exist in the red space; and hence it follows, that those eyes which see only two colours, viz. *yellow* and *blue*, in the spectrum, are really insensible to the red light of the spectrum, and see only the yellow with the small portion of blue with which the red is mixed. The faintness of the yellow light which is thus seen in the red space, confirms the opinion that the retina has not appreciated the influence of the simple red rays.

If one of the two travellers who, in the fable of the chameleon, are made to quarrel about the colour of that singular animal, had happened to possess this defect of sight, they would have encountered at every step of their journey, new grounds of dissension, without the chance of finding an umpire who could pronounce a satisfactory decision. Under certain circumstances, indeed, the arbiter might set aside the opinions of both the disputants, and render it necessary to appeal to some higher authority,

--- to beg he'd tell them if he knew
Whether the thing was *red* or *blue*.

Fig. 2.

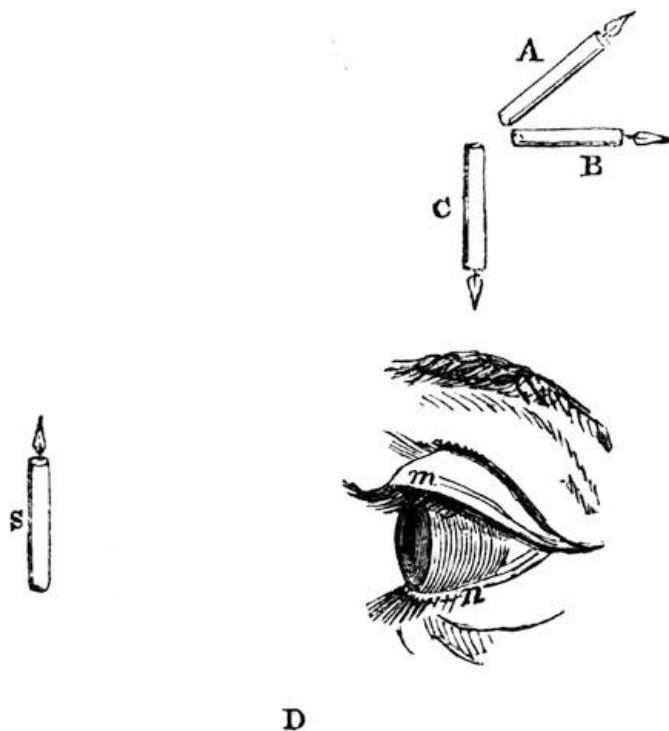

In the course of writing the preceding observations an ocular illusion occurred to myself of so extraordinary a nature, that I am convinced it never was seen before, and I think it far from probable that it will ever be seen again. Upon directing my eyes to the candles that were standing before me, I was surprised to observe, apparently among my hair, and nearly straight above my head, and far without the range of vision, a distinct image of one of the candles inclined about 45° to the horizon, as shown at A in Fig. 2. The image was as distinct and perfect as if it had been formed by reflection from a piece of mirror glass, though of course much less brilliant, and the position of the image proved that it must be formed by reflection from a perfectly flat and highly polished surface. But where such a surface could be placed, and how, even if it were fixed, it could reflect the image of the candle up through my head, were difficulties not a little perplexing. Thinking that it might be something lodged in the eyebrow, I covered it up from the light, but the image still retained its place. I then examined the eyelashes with as little success, and was driven to the extreme supposition that a crystallization was taking place in some part of the aqueous humour of the eye, and that the image was formed by the reflection of the light of

the candle from one of the crystalline faces. In this state of uncertainty, and, I may add, of anxiety, for this last supposition was by no means an agreeable one, I set myself down to examine the phenomenon experimentally. I found that the image varied its place by the motion of the head and of the eyeball, which proved that it was either attached to the eyeball or occupied a place where it was affected by that motion. Upon inclining the candle at different angles, the image suffered corresponding variations of position. In order to determine the exact place of the reflecting substance, I now took an opaque circular body and held it between the eye and the candle till it eclipsed the mysterious image. By bringing the body nearer and nearer the eyeball till its shadow became sufficiently distinct to be seen, it was easy to determine the locality of the reflector, because the shadow of the opaque body must fall upon it whenever the image of the candle was eclipsed. In this way I ascertained that the reflecting body was in the upper eyelash; and I found, that, in consequence of being disturbed, it had twice changed its inclination, so as to represent a vertical candle in the horizontal position B, and afterwards in the inverted position C. Still, however, I sought for it in vain, and even with the aid of a magnifier I could not discover it. At last, however, Mrs. B., who possesses the perfect vision of short-sighted persons, discovered, after repeated examinations, between two eyelashes, a minute speck, which, upon being removed with great difficulty, turned out to be a chip of red wax not above the hundredth part of an inch in diameter, and having its surface so perfectly flat and so highly polished that I could see in it the same image of the candle, by placing it extremely near the eye. This chip of wax had no doubt received its flatness and its polish from the surface of a seal, and had started into my eye when breaking the seal of a letter.

That this reflecting substance was the cause of the image of the candle, cannot admit of a doubt; but the wonder still remains how the images which it formed occupied so mysterious a place as to be seen without the range of vision, and apparently through the head. In order to explain this, let $m n$, Fig. 2, be a lateral view of the eye. The chip of wax was placed at m at the root of the eyelashes, and being nearly in contact with the outer surface of the cornea, the light of the candle, which it reflected, passed very obliquely through the pupil and fell upon the retina somewhere to the left of n , very near where the retina terminates; but a ray thus falling obliquely on the retina is seen, in virtue of the law of visible direction already explained, in a line $n C$ perpendicular to the retina at the point near n , where the ray fell. Hence the candle was necessarily seen through the head as it were of the observer, and without the range of ordinary vision. The comparative brightness of the reflected image still surprises me; but even this, if the image really was brighter, may be explained by the fact, that it was formed on a part of the retina upon which light had never before fallen, and which may therefore be supposed to be more sensible, than the parts of the membrane in constant use, to luminous impressions.

Independent of its interest as an example of the marvellous in vision, the preceding fact may be considered as a proof that the retina retains its power to its very termination near the ciliary processes, and that the law of visible direction holds true even without the range of ordinary vision. It is therefore possible that a reflecting surface favourably placed on the outside of the eye, or that a reflecting surface in the inside of the eye, may cause a luminous image to fall nearly on the extreme margin of the retina, the consequence of which would be, that it would be seen in the back of the head, half way between a vertical and a horizontal line.

LETTER III.

Subject of spectral illusions—Recent and interesting case of Mrs. A.—Her first illusion affecting the ear—Spectral apparition of her husband—Spectral apparition of a cat—Apparition of a near and living relation in grave-clothes, seen in a looking-glass—Other illusions, affecting the ear—Spectre of a deceased friend sitting in an easy-chair—Spectre of a coach-and-four filled with skeletons—Accuracy and value of the preceding cases—State of health under which they arose—Spectral apparitions are pictures on the retina—The ideas of memory and imagination are also pictures on the retina—General views of the subject—Approximate explanation of spectral apparitions.

The preceding account of the different sources of illusion to which the eye is subject is not only useful as indicating the probable cause of any individual deception, but it has a special importance in preparing the mind for understanding those more vivid and permanent spectral illusions to which some individuals have been either occasionally or habitually subject.

In these lesser phenomena, we find the retina so powerfully influenced by external impressions, as to retain the view of visible objects long after they are withdrawn: we observe it to be so excited by local pressures of which we sometimes know neither the nature nor the origin, as to see in total darkness moving and shapeless masses of coloured light; and we find, as in the case of Sir Isaac Newton, and others, that the imagination has the power of reviving the impressions of highly luminous objects, months and even years after they were first made. From such phenomena, the mind feels it to be no violent transition to pass to those spectral illusions which, in particular states of health, have haunted the most intelligent individuals, not only in the broad light of day, but in the very heart of the social circle.

This curious subject has been so ably and fully treated in your Letters on Demonology, that it would be presumptuous in me to resume any part of it on which you have even touched; but as it forms a necessary branch of a Treatise on Natural Magic, and as one of the most remarkable cases on record has come within my own knowledge, I shall make no apology for giving a full account of the different spectral appearances which it embraces, and of adding the results of a series of observations and experiments on which I have been long occupied, with the view of throwing some light on this remarkable class of phenomena.

A few years ago, I had occasion to spend some days under the same roof with the lady to whose case I have above referred. At that time she had seen no spectral illusions, and was acquainted with the subject only from the interesting volume of Dr. Hibbert. In conversing with her about the cause of these apparitions, I mentioned, that if she should ever see such a thing, she might distinguish a genuine ghost, existing externally, and seen as an external object, from one created by the mind, by merely pressing one eye or straining them both, so as to see objects double; for in this case the external object or supposed apparition would invariably be doubled, while the impression on the retina created by the mind would remain single. This observation recurred to her mind when she unfortunately became subject to the same illusions; but she was too well acquainted with their nature to require any such evidence of their mental origin; and the state of agitation which generally accompanies them seems to have prevented her from making the experiment as a matter of curiosity.

1. The first illusion to which Mrs. A. was subject was one which affected only the ear. On the 26th of December, 1830, about half-past four in the afternoon, she was standing near the fire in the hall, and on the point of going up stairs to dress, when she heard, as she supposed, her husband's voice calling her by name, "— Come here! come to me!" She imagined that he was calling at the door to have it opened, but upon going there and opening the door she was surprised to find no person there. Upon returning to the fire, she again heard the same voice calling out very distinctly and loudly, "— Come, come here!" She then opened two doors of the same room, and upon seeing no person she returned to the fire-place. After a few moments she heard the same voice still calling, "— --- Come to me, come! come away!" in a loud, plaintive, and somewhat impatient tone. She answered as loudly, "Where are you? I don't know where you are;" still imagining that he was somewhere in search of her: but receiving no answer, she shortly went up stairs. On Mr. A.'s return to the house, about half an hour afterwards, she inquired why he called to her so often, and where he was; and she was, of course, greatly surprised to learn that he had not been near the house at the time. A similar illusion, which excited no particular notice at the time, occurred to Mrs. A. when residing at Florence about ten years before, and when she was in perfect health. When she was undressing after a ball, she heard a voice call her repeatedly by name, and she was at that time unable to account for it.

2. The next illusion which occurred to Mrs. A. was of a more alarming character. On the 30th of December, about four o'clock in the afternoon, Mrs. A. came down stairs into the drawing-room, which she had quitted only a few minutes before, and on entering the room she saw her husband, as she supposed, standing with his back to the fire. As he had gone out to take a walk about half an hour before, she was surprised to see him there, and asked him why he had returned so soon. The figure looked fixedly at her with a serious and thoughtful expression of countenance, but did not speak. Supposing that his mind was absorbed in thought, she sat down in an arm-chair near the fire, and within two feet at most of the figure, which she still saw standing before her. As its eyes, however, still continued to be fixed upon her, she said, after the lapse of a few minutes, "Why don't you speak,—"?" The figure immediately moved off towards the window at the further end of the room, with its eyes still gazing on her, and it passed so very close to her in doing so, that she was struck by the circumstance of hearing no step nor sound, nor feeling her clothes brushed against, nor even any agitation in the air. Although she was now convinced that the figure was not her husband, yet she never for a moment supposed that it was anything

supernatural, and was soon convinced that it was a spectral illusion. As soon as this conviction had established itself in her mind, she recollected the experiment which I had suggested, of trying to double the object: but before she was able distinctly to do this, the figure had retreated to the window, where it disappeared. Mrs. A. immediately followed it, shook the curtains and examined the window, the impression having been so distinct and forcible that she was unwilling to believe that it was not a reality. Finding, however, that the figure had no natural means of escape, she was convinced that she had seen a spectral apparition like those recorded in Dr. Hibbert's work, and she consequently felt no alarm or agitation. The appearance was seen in bright daylight, and lasted four or five minutes. When the figure stood close to her it concealed the real objects behind it, and the apparition was fully as vivid as the reality.

3. On these two occasions Mrs. A. was alone, but when the next phantasm appeared her husband was present. This took place on the 4th of January, 1830. About ten o'clock at night, when Mr. and Mrs. A. were sitting in the drawing-room, Mr. A. took up the poker to stir the fire, and when he was in the act of doing this, Mrs. A. exclaimed, "Why there's the cat in the room!" "Where?" asked Mr. A. "There, close to you," she replied. "Where?" he repeated. "Why on the rug, to be sure, between yourself and the coal-scuttle." Mr. A., who had still the poker in his hand, pushed it in the direction mentioned: "Take care," cried Mrs. A., "take care, you are hitting her with the poker." Mr. A. again asked her to point out exactly where she saw the cat. She replied, "Why sitting up there close to your feet on the rug. She is looking at me. It is Kitty—come here, Kitty!"—There were two cats in the house, one of which went by this name, and they were rarely if ever in the drawing-room. At this time Mrs. A. had no idea that the sight of the cat was an illusion. When she was asked to touch it, she got up for the purpose, and seemed as if she were pursuing something which moved away. She followed a few steps, and then said, "It has gone under the chair." Mr. A. assured her it was an illusion, but she would not believe it. He then lifted up the chair, and Mrs. A. saw nothing more of it. The room was then searched all over, and nothing found in it. There was a dog lying on the hearth, who would have betrayed great uneasiness if a cat had been in the room, but he lay perfectly quiet. In order to be quite certain, Mr. A. rang the bell, and sent for the two cats, both of which were found in the housekeeper's room.

4. About a month after this occurrence, Mrs. A., who had taken a somewhat fatiguing drive during the day, was preparing to go to bed about eleven o'clock at night, and, sitting before the dressing-glass, was occupied in arranging her hair. She was in a listless and drowsy state of mind, but fully awake. When her fingers were in active motion among the papillotes, she was suddenly startled by seeing in the mirror the figure of a near relation, who was then in Scotland and in perfect health. The apparition appeared over her left shoulder, and its eyes met hers in the glass. It was enveloped in grave-clothes, closely pinned, as is usual with corpses, round the head, and under the chin, and though the eyes were open, the features were solemn and rigid. The dress was evidently a shroud, as Mrs. A. remarked even the punctured pattern usually worked in a peculiar manner round the edges of that garment. Mrs. A. described herself as at the time sensible of a feeling like what we conceive of fascination, compelling her for a time to gaze on this melancholy apparition, which was as distinct and vivid as any reflected reality could be, the light of the candles upon the dressing-table appearing to shine fully upon its face. After a few minutes, she turned round to look for the reality of the form over her shoulder; but it was not visible, and it had also disappeared from the glass when she looked again in that direction.

5. In the beginning of March, when Mr. A. had been about a fortnight from home, Mrs. A. frequently heard him moving near her. Nearly every night, as she lay awake, she distinctly heard sounds like his breathing hard on the pillow by her side, and other sounds such as he might make while turning in bed.

6. On another occasion, during Mr. A.'s absence, while riding with a neighbour, Mr.—, she heard his voice frequently as if he were riding by his side. She heard also the tramp of his horse's feet, and was almost puzzled by hearing him address her at the same time with the person really in company. His voice made remarks on the scenery, improvements, &c., such as he probably should have done had he been present. On this occasion, however, there was no visible apparition.

7. On the 17th March, Mrs. A. was preparing for bed. She had dismissed her maid, and was sitting with her feet in hot water. Having an excellent memory, she had been thinking upon and repeating to herself a striking passage in the Edinburgh Review, when on raising her eyes, she saw seated in a large easy-chair before her the figure of a deceased friend, the sister of Mr. A. The figure was dressed as had been usual with her, with great neatness, but in a gown of a peculiar kind, such as Mrs. A. had never seen her wear, but exactly such as had been described to her by a common friend as having been worn by Mr. A.'s sister during her last visit to England. Mrs. A. paid particular attention to the dress, air, and appearance of the figure, which sat in an easy attitude in the chair, holding a handkerchief in one hand. Mrs. A. tried to speak to it, but experienced a difficulty in doing so; and in about three minutes the figure disappeared. About a minute afterwards, Mr. A. came into the room, and found Mrs. A. slightly nervous, but fully aware of the delusive nature of the apparition. She described it as having all the vivid colouring and apparent reality of life; and for some hours preceding this and other visions, she experienced a peculiar sensation in her eyes, which seemed to be relieved when the vision had ceased.

8. On the 5th October, between one and two o'clock in the morning, Mr. A. was awoken by Mrs. A., who told him that she had just seen the figure of his deceased mother draw aside the bedcurtains and appear between them. The dress and the look of the apparition were precisely those in which

Mr. A.'s mother had been last seen by Mrs. A. at Paris, in 1824.

9. On the 11th October, when sitting in the drawing-room, on one side of the fire-place, she saw the figure of another deceased friend moving towards her from the window at the further end of the room. It approached the fire-place, and sat down in the chair opposite. As there were several persons in the room at the time, she describes the idea uppermost in her mind to have been a fear lest they should be alarmed at her staring, in the way she was conscious of doing, at vacancy, and should fancy her intellect disordered. Under the influence of this fear, and recollecting a story of a similar effect in your work on Demonology, which she had lately read, she summoned up the requisite resolution to enable her to cross the space before the fire-place, and seat herself in the same chair with the figure. The apparition remained perfectly distinct till she sat down, as it were, in its lap, when it vanished.

10. On the 26th of the same month, about two P.M., Mrs. A. was sitting in a chair by the window in the same room with her husband. He heard her exclaim—"What have I seen?" And on looking at her, he observed a strange expression in her eyes and countenance. A carriage-and-four had appeared to her to be driving up the entrance-road to the house. As it approached, she felt inclined to go up stairs to prepare to receive company, but, as if spellbound, she was unable to move or speak. The carriage approached, and as it arrived within a few yards of the window, she saw the figures of the postilions and the persons inside take the ghastly appearance of skeletons and other hideous figures. The whole then vanished entirely, when she uttered the above-mentioned exclamation.

11. On the morning of the 30th October, when Mrs. A. was sitting in her own room with a favourite dog in her lap, she distinctly saw the same dog moving about the room during the space of about a minute or rather more.

12. On the 3rd December, about nine P.M., when Mr. and Mrs. A. were sitting near each other in the drawing-room occupied in reading, Mr. A. felt a pressure on his foot. On looking up he observed Mrs. A.'s eyes fixed with a strong and unnatural stare on a chair about nine or ten feet distant. Upon asking her what she saw, the expression of her countenance changed, and upon recovering herself, she told Mr. A. that she had seen his brother, who was alive and well at the moment in London, seated in the opposite chair, but dressed in grave-clothes, and with a ghastly countenance, as if scarcely alive.

Such is a brief account of the various spectral illusions observed by Mrs. A. In describing them I have used the very words employed by her husband in his communications to me on the subject;⁵ and the reader may be assured that the descriptions are neither heightened by fancy, nor amplified by invention. The high character and intelligence of the lady, and the station of her husband in society, and as a man of learning and science, would authenticate the most marvellous narrative, and satisfy the most scrupulous mind, that the case has been philosophically as well as faithfully described. In narrating events which we regard as of a supernatural character, the mind has a strong tendency to give more prominence to what appears to itself the most wonderful; but from the very same cause, when we describe extraordinary and inexplicable phenomena which we believe to be the result of natural causes, the mind is prone to strip them of their most marvellous points, and bring them down to the level of ordinary events. From the very commencement of the spectral illusions seen by Mrs. A., both she and her husband were well aware of their nature and origin, and both of them paid the most minute attention to the circumstances which accompanied them, not only with the view of throwing light upon so curious a subject, but for the purpose of ascertaining their connection with the state of health under which they appeared.

As the spectres seen by Nicolai and others had their origin in bodily indisposition, it becomes interesting to learn the state of Mrs. A.'s health when she was under the influence of these illusions. During the six weeks within which the first three illusions took place, she had been considerably reduced and weakened by a troublesome cough, and the weakness which this occasioned was increased by her being prevented from taking a daily tonic. Her general health had not been strong, and long experience has put it beyond a doubt, that her indisposition arises from a disordered state of the digestive organs. Mrs. A. has naturally a morbidly sensitive imagination, which so painfully affects her corporeal impressions, that the account of any person having suffered severe pain by accident or otherwise, occasionally produces acute twinges of pain in the corresponding parts of her person. The account, for example, of the amputation of an arm will produce an instantaneous and severe sense of pain in her own arm. She is subject to talk in her sleep with great fluency, to repeat long passages of poetry, particularly when she is unwell, and even to cap verses for half an hour together, never failing to quote lines beginning with the final letter of the preceding one till her memory is exhausted.

Although it is not probable that we shall ever be able to understand the actual manner in which a person of sound mind beholds spectral apparitions in the broad light of day, yet we may arrive at such a degree of knowledge on the subject as to satisfy rational curiosity, and to strip the phenomena of every attribute of the marvellous. Even the vision of natural objects presents to us insurmountable difficulties, if we seek to understand the precise part which the mind performs in perceiving them; but the philosopher considers that he has given a satisfactory explanation of vision, when he demonstrates that distinct pictures of external objects are painted on the retina, and that this membrane communicates with the brain by means of nerves of the same substance as itself, and of which it is merely an expansion. Here we reach the gulf which human intelligence cannot pass; and if the presumptuous mind of man shall dare to extend its speculations farther, it

will do it only to evince its incapacity and mortify its pride.

In his admirable work on this subject, Dr. Hibbert has shown that spectral apparitions are nothing more than ideas or the recollected images of the mind, which, in certain states of bodily indisposition, have been rendered more vivid than actual impression, or, to use other words, that the pictures in the "mind's eye" are more vivid than the pictures in the body's eye. This principle has been placed by Dr. Hibbert beyond the reach of doubt; but I propose to go much farther, and to show that the "mind's eye" is actually the body's eye, and that the retina is the common tablet on which both classes of impressions are painted, and by means of which they receive their visual existence according to the same optical laws. Nor is this true merely in the case of spectral illusions; it holds good of all ideas recalled by the memory or created by the imagination, and may be regarded as a fundamental law in the science of pneumatology.

It would be out of place in a work like this to adduce the experimental evidence on which it rests, or even to explain the manner in which the experiments themselves must be conducted: but I may state in general, that the spectres conjured up by the memory or the fancy have always a "local habitation," and that they appear in front of the eye, and partake in its movements exactly like the impressions of luminous objects, after the objects themselves are withdrawn.

In the healthy state of the mind and body, the relative intensity of these two classes of impressions on the retina is nicely adjusted. The mental pictures are transient and comparatively feeble, and in ordinary temperaments are never capable of disturbing or effacing the direct images of visible objects. The affairs of life could not be carried on if the memory were to intrude bright representations of the past into the domestic scene, or scatter them over the external landscape. The two opposite impressions, indeed, could not co-exist: the same nervous fibre which is carrying from the brain to the retina the figures of memory, could not at the same instant be carrying back the impressions of external objects from the retina to the brain. The mind cannot perform two different functions at the same instant, and the direction of its attention to one of the two classes of impressions necessarily produces the extinction of the other: but so rapid is the exercise of mental power, that the alternate appearance and disappearance of the two contending impressions are no more recognized than the successive observations of external objects during the twinkling of the eyelids. If we look for example at the façade of St. Paul's, and without changing our position call to mind the celebrated view of Mont Blanc from Lyons, the picture of the cathedral, though actually impressed upon the retina, is momentarily lost sight of by the mind, exactly like an object seen by indirect vision; and during the instant the recollected image of the mountain, towering over the subjacent range, is distinctly seen, but in a tone of subdued colouring and indistinct outline. When the purpose of its recall is answered, it quickly disappears, and the picture of the cathedral again resumes the ascendancy.

In darkness and solitude, when external objects no longer interfere with the pictures of the mind, they become more vivid and distinct; and in the state between waking and sleeping the intensity of the impressions approaches to that of visible objects. With persons of studious habits, who are much occupied with the operations of their own minds, the mental pictures are much more distinct than in ordinary persons; and in the midst of abstract thought, external objects even cease to make any impression on the retina. A philosopher absorbed in his contemplations experiences a temporary privation of the use of his senses. His children or his servants will enter the room directly before his eyes without being seen. They will speak to him without being heard; and they will even try to rouse him from his reverie without being felt; although his eyes, his ears, and his nerves actually receive the impressions of light, sound, and touch. In such cases, however, the philosopher is voluntarily pursuing a train of thought on which his mind is deeply interested; but even ordinary men, not much addicted to speculations of any kind, often perceive in their mind's eye the pictures of deceased or absent friends, or even ludicrous creations of fancy, which have no connexion whatever with the train of their thoughts. Like spectral apparitions they are entirely involuntary, and though they may have sprung from a regular series of associations, yet it is frequently impossible to discover a single link in the chain.

If it be true, then, that the pictures of the mind and spectral illusions are equally impressions upon the retina, the latter will differ in no respect from the former, but in the degree of vividness with which they are seen; and those frightful apparitions become nothing more than our ordinary ideas, rendered more brilliant by some accidental and temporary derangement of the vital functions. Their very vividness, too, which is their only characteristic, is capable of explanation. I have already shown that the retina is rendered more sensible to light by voluntary local pressure, as well as by the involuntary pressure of the blood-vessels behind it; and if, by looking at the sun, we impress upon the retina a coloured image of that luminary, which is seen even when the eye is shut, we may by pressure alter the colour of that image, in consequence of having increased the sensibility of that part of the retina on which it is impressed. Hence we may readily understand how the vividness of the mental pictures must be increased by analogous causes.

In the case both of Nicolai and Mrs. A. the immediate cause of the spectres was a deranged action of the stomach. When such a derangement is induced by poison, or by substances which act as poisons, the retina is peculiarly affected, and the phenomena of vision are singularly changed. Dr. Patouillet has described the case of a family of *nine* persons who were all driven mad by eating the root of the *hyoscyamus niger*, or black henbane. One of them leapt into a pond, another exclaimed that his neighbour would lose a cow in a month, and a third vociferated that the crown piece of sixty pence would in a short time rise to five livres. On the following day they had all recovered their senses, but recollected nothing of what had happened. On the same day they all saw objects double, and, what is still more remarkable, on the third day *every object*

appeared to them as red as scarlet. Now this red light was probably nothing more than the red phosphorescence produced by the pressure of the blood-vessels on the retina, and analogous to the masses of *blue, green, yellow,* and *red* light, which have been already mentioned as produced by a similar pressure in headaches, arising from a disordered state of the digestive organs.

Were we to analyse the various phenomena of spectral illusions, we should discover many circumstances favourable to these views. In those seen by Nicolai, the individual figures were always somewhat paler than natural objects. They sometimes grew more and more indistinct, and became perfectly white; and, to use his own words, "he could always distinguish with the greatest precision phantasms from phenomena." Nicolai sometimes saw the spectres when his eyes were shut, and sometimes they were thus made to disappear,—effects perfectly identical with those which arise from the impressions of very luminous objects. Sometimes the figures vanished entirely, and at other times only pieces of them disappeared, exactly conformable to what takes place with objects seen by indirect vision, which most of those figures must necessarily have been.

Among the peculiarities of spectral illusions, there is one which merits particular attention, namely, that they seem to cover or conceal objects immediately beyond them. It is this circumstance more than any other which gives them the character of reality, and at first sight it seems difficult of explanation. The distinctness of any impression on the retina is entirely independent of the accommodation of the eye to the distinct vision of external objects. When the eye is at rest, and is not accommodated to objects at any particular distance, it is in a state for seeing distant objects most perfectly. When a distinct spectral impression, therefore, is before it, all other objects in its vicinity will be seen indistinctly, for while the eye is engrossed with the vision, it is not likely to accommodate itself to any other object in the same direction. It is quite common, too, for the eye to see only one of two objects actually presented to it. A sportsman who has been in the practice of shooting with both his eyes open, actually sees a double image of the muzzle of his fowling-piece, though it is only with one of these images that he covers his game, having no perception whatever of the other. But there is still another principle upon which only one of two objects may be seen at a time. If we look very steadily and continuously at a double pattern, such as those on a carpet composed of two single patterns of different colours, suppose *red* and *yellow*; and if we direct the mind particularly to the contemplation of the red one, the green pattern will sometimes vanish entirely, leaving the red alone visible; and by the same process the red one may be made to disappear. In this case, however, the two patterns, like the two images, may be seen together; but if the very same portion of the retina is excited by the direct rays of an external object, when it is excited by a mental impression, it can no more see them both at the same time, than a vibrating string can give out two different fundamental sounds. It is quite possible, however, that the brightest parts of a spectral figure may be distinctly seen along with the brightest parts of an object immediately behind it, but then the bright parts of each object will fall upon different parts of the retina.

These views are illustrated by a case mentioned by Dr. Abercrombie. A gentleman, who was a patient of his, of an irritable habit, and liable to a variety of uneasy sensations in his head, was sitting alone in his dining-room in the twilight, when the door of the room was a little open. He saw distinctly a female figure enter, wrapped in a mantle, with the face concealed by a large black bonnet. She seemed to advance a few steps towards him, and then stop. He had a full conviction that the figure was an illusion of vision, and he amused himself for some time by watching it; at the same time observing that he could see through the figure so as to perceive the lock of the door, and other objects behind it.⁶

If these views be correct, the phenomena of spectral apparitions are stripped of all their terror, whether we view them in their supernatural character, or as indications of bodily indisposition. Nicolai, even, in whose case they were accompanied with alarming symptoms, derived pleasure from the contemplation of them, and he not only recovered from the complaint in which they originated, but survived them for many years.—Mrs. A., too, who sees them only at distant intervals, and with whom they have but a fleeting existence, will, we trust, soon lose her exclusive privilege, when the slight indisposition which gives them birth has subsided.

LETTER IV.

Science used as an instrument of imposture—Deceptions with plane and concave mirrors practised by the ancients—The magician's mirror—Effects of concave mirrors—Aërial images—Images on smoke—Combination of mirrors for producing pictures from living objects—The mysterious dagger—Ancient miracles with concave mirrors—Modern necromancy with them, as seen by Cellini—Description and effects of the magic lantern—Improvements upon it—Phantasmagoric exhibitions of Philipstall and others—Dr. Young's arrangement of lenses, &c., for the Phantasmagoria—Improvements suggested—Catadioptrical phantasmagoria for producing the pictures from living objects—Method of cutting off parts of the figures—Kircher's mysterious hand-writing on the wall—His hollow cylindrical mirror for aërial images—Cylindrical mirror for re-forming distorted pictures—Mirrors of variable curvature for producing caricatures.

In the preceding observations man appears as the victim of his own delusions—as the magician unable to exercise the spirits which he has himself called into being. We shall now see him the dupe of preconcerted imposture—the slave of his own ignorance—the prostrate vassal of power and superstition. I have already stated that the monarchs and priests of ancient times carried on a systematic plan of imposing upon their subjects—a mode of government which was in perfect accordance with their religious belief: but it will scarcely be believed that the same delusions were practised after the establishment of Christianity, and that even the Catholic sanctuary was often the seat of these unhallowed machinations. Nor was it merely the low and cunning priest who thus sought to extort money and respect from the most ignorant of his flock: bishops and pontiffs themselves wielded the magician's wand over the diadem of kings and emperors, and, by the pretended exhibition of supernatural power, made the mightiest potentates of Europe tremble upon their thrones. It was the light of science alone which dispelled this moral and intellectual darkness, and it is entirely in consequence of its wide diffusion that we live in times when sovereigns seek to reign only through the affections of their people, and when the minister of religion asks no other reverence but that which is inspired by the sanctity of his office and the purity of his character.

It was fortunate for the human race that the scanty knowledge of former ages afforded so few elements of deception. What a tremendous engine would have been worked against our species by the varied and powerful machinery of modern science! Man would still have worn the shackles which it forged, and his noble spirit would still have groaned beneath its fatal pressure.

There can be little doubt that the most common, as well as the most successful, impositions of the ancients were of an optical nature, and were practised by means of plane and concave mirrors. It has been clearly shown by various writers that the ancients made use of mirrors of steel, silver, and a composition of copper and tin, like those now used for reflecting specula. It is also very probable, from a passage in Pliny, that glass mirrors were made at Sidon; but it is evident, that, unless the object presented to them was illuminated in a very high degree, the images which they formed must have been very faint and unsatisfactory. The silver mirrors, therefore, which were universally used, and which are superior to those made of any other metal, are likely to have been most generally employed by the ancient magicians. They were made to give multiplied and inverted images of objects, that is, they were plane, polygonal or many-sided, and concave. There is one property, however, mentioned by Aulus Gellius, which has given unnecessary perplexity to commentators. He states that there were specula, which, when put in a particular place, gave no images of objects, but when carried to another place, recovered their property of reflection.⁷ M. Salvete is of opinion that, in quoting Varro, Aulus Gellius was not sufficiently acquainted with the subject, and erred in supposing that the phenomenon depended on the *place* instead of the position of the mirror; but this criticism is obviously made with the view of supporting an opinion of his own—that the property in question may be analogous to the phenomenon of polarised light, which, at a certain angle, refuses to suffer reflexion from particular bodies. If this idea has any foundation, the mirror must have been of glass or some other body not metallic, or, to speak more correctly, there must have been *two* such mirrors, so nicely adjusted not only to one another, but to the light incident upon each, that the effect could not possibly be produced but by a philosopher thoroughly acquainted with the modern discovery of the polarisation of light by reflexion. Without seeking for so profound an explanation of the phenomenon, we may readily understand how a silver mirror may instantly lose its reflecting power in a damp atmosphere, in consequence of the precipitation of moisture upon its surface, and may immediately recover it when transported into drier air.

Fig. 3.

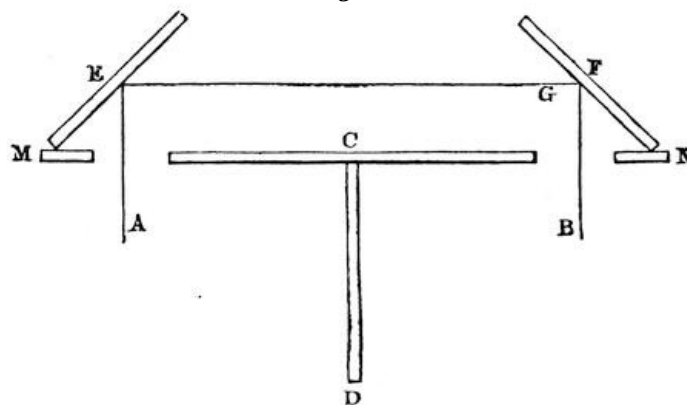

One of the simplest instruments of optical deception is the plane mirror, and when two are combined for this purpose it has been called the magician's mirror. An observer in front of a plane mirror sees a distinct image of himself; but if two persons take up a mirror, and if the one person is as much to one side of a line perpendicular to the middle of it as the other is to the other side, they will see each other, but not themselves. If we now suppose MC, CD, NC, CD to be the partitions of two adjacent apartments let square openings be made in the partitions at A and B, above five feet above the floor, and let them be filled with plate glass, and surrounded with a picture frame, so as to have the appearance of two mirrors. Place two mirrors, E, F, one behind each opening at A and B, inclined 45° to the partition MN, and so large that a person looking into the plates of glass at A and B will not see their edges. When this is done it is obvious that a person looking into the mirror A will not see himself, but will see any person or figure placed at B. If he believes that he is looking into a common mirror at A, his astonishment will be great at seeing himself transformed into another person, or into any living animal that may be placed at B. The success of this deception would be greatly increased if a plane mirror, suspended by a pulley, could be brought immediately behind the plane glass at A, and drawn up from it at pleasure. The spectator at A, having previously seen himself in this moveable mirror, would be still more astonished when he afterwards perceived in the same place a face different from his own. By drawing the moveable mirror half up, the spectator at A might see half of his own face joined to half of the face placed at B; but in the present day the most ignorant persons are so familiar with the properties of a looking-glass, that it would be very difficult to employ this kind of deception with the same success which must have attended it in a more illiterate age. The optical reader will easily see that the mirror F and the apartment NCD are not absolutely necessary for carrying on this deception; for the very same effects will be produced if the person at B is stationed at G, and looks towards the mirror F in the direction GF. As the mirror F, however, must be placed as near to A as possible, the person at G would be too near the partition CN, unless the mirror F was extremely large.

The effect of this and every similar deception is greatly increased when the persons are illuminated with a strong light, and the rest of the apartment as dark as possible; but whatever precautions are taken, and however skilfully plane mirrors are combined, it is not easy to produce with them any very successful illusions.

The concave mirror is the staple instrument of the magician's cabinet, and must always perform a principal part in all optical combinations. In order to be quite perfect, every concave mirror should have its surface elliptical, so that if any object is placed in one focus of the ellipse, an inverted image of it will be formed in the other focus. This image, to a spectator rightly placed, appears suspended in the air, so that if the mirror and the object are hid from his view, the effect must appear to him almost supernatural.

The method of exhibiting the effect of concave mirrors most advantageously is shown in Fig. 4, where CD is the partition of a room having in it a square opening EF, the centre of which is about five feet above the floor. This opening might be surrounded with a picture-frame, and a painting which exactly filled it might be so connected with a pulley that it could be either slipped aside, or raised so as to leave the frame empty. A large concave mirror MN is then placed in another apartment, so that when any object is placed at A, a distinct image of it may be formed in the centre of the opening EF. Let us suppose this object to be a plaster cast of any object made as white as possible, and placed in an *inverted* position at A. A strong light should then be thrown upon it by a powerful lamp, the rays of which are prevented from reaching the opening EF. When this is done, a spectator placed at O will see an erect image of the statue at B, the centre of the opening, standing in the air, and differing from the real statue only in being a little larger, while the apparition will be wholly invisible to other spectators placed at a little distance on each side of him.

Fig. 4.

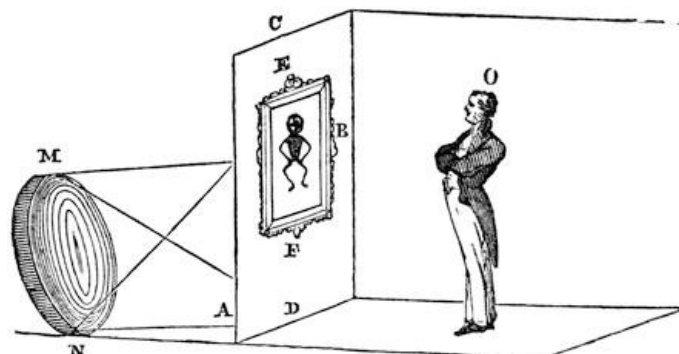

If the opening EF is filled with smoke, rising either from a chafing-dish, in which incense is burnt, or made to issue in clouds from some opening below, the image will appear in the middle of the smoke depicted upon it as upon a ground, and capable of being seen by those spectators who could not see the image of the air. The rays of light, in place of proceeding without obstruction to an eye at O, are reflected as it were from those minute particles of which the smoke is composed, in the same manner as a beam of light is rendered more visible by passing through an apartment filled with dust or smoke.

It has long been a favourite experiment to place at A a white and strongly illuminated human skull, and to exhibit an image of it amid the smoke of a chafing-dish at B; but a more terrific effect would be produced if a small skeleton suspended by invisible wires were placed as an object at A. Its image suspended in the air at B, or painted upon smoke, could not fail to astonish the spectator.

The difficulty of placing a living person in an inverted position, as an object at A, has no doubt prevented the optical conjuror from availing himself of so admirable a resource; but this difficulty may be removed by employing a second concave mirror. The second mirror may be so placed as to reflect towards MN the rays proceeding from an erect living object, and to form an inverted image of this object at A. An erect image of this inverted image will then be formed at B, either suspended in the air, or depicted upon a wreath of smoke. This aërial image will exhibit the precise form and colours and movements of the living object, and it will maintain its character as an apparition if any attempt is made by the spectator to grasp its unsubstantial fabric.

A deception of an alarming kind, called the *Mysterious dagger*, has been long a favourite exhibition. If a person with a drawn and highly polished dagger, illuminated by a strong light, stands a little farther from a concave mirror than its principal focus, he will perceive in the air between himself and the mirror an inverted and diminished image of his own person, with the dagger similarly brandished. If he aims the dagger at the centre of the mirror's concavity, the two daggers will meet point to point, and, by pushing it still farther from him towards the mirror, the imaginary dagger will strike at his heart. In this case it is necessary that the direction of the real dagger coincides with a diameter of the sphere of which the mirror is a part; but if its direction is on one side of that diameter, the direction of the imaginary dagger will be as far on the other side of the diameter, and the latter will aim a blow at any person who is placed in the proper position for receiving it. If the person who bears the real dagger is therefore placed behind a screen, or otherwise concealed from the view of the spectator, who is made to approach to the place of the image, the thrust of the polished steel at his breast will not fail to produce a powerful impression. The effect of this experiment would no doubt be increased by covering with black cloth the person who holds the dagger, so that the image of his hand only should be seen, as the inverted picture of him would take away from the reality of the appearance. By using two mirrors, indeed, this defect might be remedied, and the spectator would witness an exact image of the assassin aiming the dagger at his life.

The common way of making this experiment is to place a basket of fruit above the dagger, so that a distinct aërial image of the fruit is formed in the focus of the mirror. The spectator, having been desired to take some fruit from the basket, approaches for that purpose, while a person properly concealed withdraws the real basket of fruit with one hand, and with the other advances the dagger, the image of which being no longer covered by the fruit, strikes at the body of the astonished spectator.

The powers of the concave mirror have been likewise displayed in exhibiting the apparition of an absent or deceased friend. For this purpose, a strongly illuminated bust or picture of the person is placed before the concave mirror, and a distinct image of the picture will be seen either in the air or among smoke, in the manner already described. If the background of the picture is temporarily covered with lamp-black, so that there is no light about the picture but what falls upon the figure, the effect will be more complete.

As in all experiments with concave mirrors, the size of the aërial image is to that of the real object as their distances from the mirror, we may, by varying the distance of the object, increase or diminish the size of the image. In doing this, however, the distance of the image from the mirror is at the same time changed, so that it would quit the place most suitable for its exhibition. This defect may be removed by simultaneously changing the place both of the mirror and the object, so that the image may remain stationary, expanding itself from a luminous spot to a gigantic size, and again passing through all intermediate magnitudes, till it vanishes in a cloud of light.

Those who have studied the effects of concave mirrors of a small size, and without the precautions necessary to ensure deception, cannot form any idea of the magical effect produced by this class of optical apparitions. When the instruments of illusion are themselves concealed,—when all extraneous lights but those which illuminate the real object are excluded,—when the mirrors are large and well-polished, and truly formed,—the effect of the representation on ignorant minds is altogether overpowering; while even those who know the deception, and perfectly understand its principles, are not a little surprised at its effects. The inferiority in the effects of a common concave mirror to that of a well-arranged exhibition is greater even than that of a perspective picture, hanging in an apartment, to the same picture exhibited under all the imposing accompaniments of a dioramic representation.

It can scarcely be doubted, that a concave mirror was the principal instrument by which the heathen gods were made to appear in the ancient temples. In the imperfect accounts which have reached us of these apparitions, we can trace all the elements of an optical illusion. In the ancient temple of Hercules at Tyre, Pliny mentions that there was a seat made of a consecrated stone, "from which the gods easily rose." Esculapius often exhibited himself to his worshippers in his temple at Tarsus; and the temple of Enguinum in Sicily was celebrated as the place where the goddesses exhibited themselves to mortals. Iamblichus actually informs us, that the ancient magicians caused the gods to appear among the vapours disengaged from fire; and when the conjuror Maximus terrified his audience by making the statue of Hecate laugh, while in the

middle of the smoke of burning incense, he was obviously dealing with the image of a living object dressed in the costume of the sorceress.

The character of these exhibitions in the ancient temples is so admirably depicted in the following passage of Damascius, quoted by M. Salverte, that we recognise all the optical effects which have been already described. "In a manifestation," says he, "which ought not to be revealed ... there appeared on the wall of the temple a mass of light, which at first seemed to be very remote; it transformed itself, in coming nearer, into a face evidently divine and supernatural, of a severe aspect, but mixed with gentleness, and extremely beautiful. According to the institutions of a mysterious religion, the Alexandrians honoured it as Osiris and Adonis."

Among more modern examples of this illusion, we may mention the case of the Emperor Basil of Macedonia. Inconsolable at the loss of his son, this sovereign had recourse to the prayers of the Pontiff Theodore Santabaren, who was celebrated for his power of working miracles. The ecclesiastical conjuror exhibited to him the image of his beloved son, magnificently dressed and mounted upon a superb charger: the youth rushed towards his father, threw himself into his arms, and disappeared. M. Salverte judiciously observes, that this deception could not have been performed by a real person who imitated the figure of the young prince. The existence of this person, betrayed by so remarkable a resemblance, and by the trick of the exhibition, could not fail to have been discovered and denounced, even if we could explain how the son could be so instantaneously disentangled from his father's embrace. The emperor, in short, saw the aerial image of a picture of his son on horseback; and as the picture was brought nearer the mirror, the image advanced into his arms, when it of course eluded his affectionate grasp.

These and other allusions to the operations of the ancient magic, though sufficiently indicative of the methods which were employed, are too meagre to convey any idea of the splendid and imposing exhibitions which must have been displayed. A national system of deception, intended as an instrument of government, must have brought into requisition not merely the scientific skill of the age, but a variety of subsidiary contrivances calculated to astonish the beholder, to confound his judgment, to dazzle his senses, and to give a predominant influence to the peculiar imposture which it was thought desirable to establish. The grandeur of the means may be inferred from their efficacy, and from the extent of their influence.

This defect, however, is, to a certain degree, supplied by an account of a modern necromancy, which has been left us by the celebrated Benvenuto Cellini, and in which he himself performed an active part.

"It happened," says he, "through a variety of odd accidents, that I made acquaintance with a Sicilian priest, who was a man of genius, and well versed in the Latin and Greek authors. Happening one day to have some conversation with him when the subject turned upon the art of necromancy, I, who had a great desire to know something of the matter, told him, that I had all my life felt a curiosity to be acquainted with the mysteries of this art.

"The priest made answer, 'that the man must be of a resolute and steady temper who enters upon that study.' I replied, 'that I had fortitude and resolution enough, if I could but find an opportunity.' The priest subjoined, 'If you think you have the heart to venture, I will give you all the satisfaction you can desire.' Thus we agreed to enter upon a plan of necromancy. The priest one evening prepared to satisfy me, and desired me to look out for a companion or two. I invited one Vincenzo Romoli, who was my intimate acquaintance: he brought with him a native of Pistoia, who cultivated the black art himself. We repaired to the Colosseo, and the priest, according to the custom of necromancers, began to draw circles upon the ground, with the most impressive ceremonies imaginable: he likewise brought hither asafœtida, several precious perfumes, and fire, with some compositions also, which diffused noisome odours. As soon as he was in readiness, he made an opening to the circle, and having taken us by the hand, ordered the other necromancer, his partner, to throw the perfumes into the fire at a proper time, entrusting the care of the fire and perfumes to the rest; and thus he began his incantations. This ceremony lasted above an hour and a half, when there appeared several legions of devils, insomuch that the amphitheatre was quite filled with them. I was busy about the perfumes, when the priest, perceiving there was a considerable number of infernal spirits, turned to me and said, 'Benvenuto, ask them something.' I answered, 'Let them bring me into the company of my Sicilian mistress Angelica.' That night he obtained no answer of any sort; but I had received great satisfaction in having my curiosity so far indulged. The necromancer told me it was requisite we should go a second time, assuring me that I should be satisfied in whatever I asked; but that I must bring with me a pure, immaculate boy.

"I took with me a youth who was in my service, of about twelve years of age, together with the same Vincenzo Romoli, who had been my companion the first time, and one Agnolino Gaddi, an intimate acquaintance, whom I likewise prevailed on to assist at the ceremony. When we came to the place appointed, the priest having made his preparations as before, with the same and even more striking ceremonies, placed us within the circle, which he had likewise drawn with a more wonderful art and in a more solemn manner than at our former meeting. Thus, having committed the care of the perfumes and the fire to my friend Vincenzo, who was assisted by Agnolino Gaddi, he put into my hand a pintaculo or magical chart, and bid me turn it towards the places that he should direct me; and under the pintaculo I held the boy. The necromancer, having begun to make his tremendous invocations, called by their names a multitude of demons who were the leaders of the several legions, and questioned them, by the power of the eternal uncreated God, who lives for ever, in the Hebrew language, as likewise in Latin and Greek; insomuch that the

amphitheatre was almost in an instant filled with demons more numerous than at the former conjuration. Vincenzo Romoli was busied in making a fire, with the assistance of Agnolino, and burning a great quantity of precious perfumes. I, by the directions of the necromancer, again desired to be in the company of my Angelica. The former thereupon turning to me said,—'Know, they have declared that, in the space of a month, you shall be in her company.'

"He thus requested me to stand resolutely by him, because the legions were now above a thousand more in number than he had designed; and besides, these were the most dangerous; so that, after they had answered my question, it behoved him to be civil to them, and dismiss them quietly. At the same time the boy under the pintaculo was in a terrible fright, saying, that there were in that place a million of fierce men, who threatened to destroy us; and that, moreover, four armed giants of enormous stature were endeavouring to break into our circle. During this time, whilst the necromancer, trembling with fear, endeavoured by mild and gentle methods to dismiss them in the best way he could, Vincenzo Romoli, who quivered like an aspen leaf, took care of the perfumes. Though I was as much terrified as any of them, I did my utmost to conceal the terror I felt; so that I greatly contributed to inspire the rest with resolution; but the truth is, I gave myself over for a dead man, seeing the horrid fright the necromancer was in. The boy placed his head between his knees and said, 'In this posture will I die; for we shall all surely perish.' I told him that all these demons were under us, and what he saw was smoke and shadow; so bid him hold up his head and take courage. No sooner did he look up than he cried out, 'The whole amphitheatre is burning, and the fire is just falling upon us.' So covering his eyes with his hands, he again exclaimed, 'that destruction was inevitable, and desired to see no more.' The necromancer entreated me to have a good heart, and take care to burn proper perfumes; upon which I turned to Romoli, and bid him burn all the most precious perfumes he had. At the same time I cast my eye upon Agnolino Gaddi, who was terrified to such a degree that he could scarce distinguish objects, and seemed to be half dead. Seeing him in this condition, I said, 'Agnolino, upon these occasions a man should not yield to fear, but should stir about and give his assistance, so come directly and put on some more of these.' The effects of poor Agnolino's fear were overpowering. The boy, hearing a crepitation, ventured once more to raise his head, when, seeing me laugh, he began to take courage, and said 'that the devils were flying away with a vengeance.'

"In this condition we stayed, till the bell rang for morning prayers. The boy again told us, that there remained but few devils, and these were at a great distance. When the magician had performed the rest of his ceremonies, he stripped off his gown, and took up a wallet full of books which he had brought with him.

"We all went out of the circle together, keeping as close to each other as we possibly could, especially the boy, who had placed himself in the middle, holding the necromancer by the coat, and me by the cloak. As we were going to our houses in the quarter of Banchi, the boy told us that two of the demons whom we had seen at the amphitheatre went on before us leaping and skipping, sometimes running upon the roofs of the houses, and sometimes upon the ground. The priest declared, that though he had often entered magic circles, nothing so extraordinary had ever happened to him. As we went along, he would fain persuade me to assist with him at consecrating a brook, from which, he said, we should derive immense riches; we should then ask the demons to discover to us the various treasures with which the earth abounds, which would raise us to opulence and power; but that these love-affairs were mere follies, from whence no good could be expected. I answered, 'that I would readily have accepted his proposal, if I understood Latin.' He redoubled his persuasions, assuring me, that the knowledge of the Latin language was by no means material. He added, that he could have Latin scholars enough, if he had thought it worth while to look out for them, but that he could never have met with a partner of resolution and intrepidity equal to mine, and that I should by all means follow his advice. Whilst we were engaged in this conversation we arrived at our respective houses, and all that night dreamt of nothing but devils."

It is impossible to peruse the preceding description without being satisfied that the legions of devils were not produced by any influence upon the imaginations of the spectators, but were actual optical phantasms, or the images of pictures or objects produced by one or more concave mirrors or lenses. A fire is lighted, and perfumes and incense are burnt, in order to create a ground for the images, and the beholders are rigidly confined within the pale of the magic circle. The concave mirror and the objects presented to it having been so placed that the persons within the circle could not see the aerial image of the objects by the rays deeply reflected from the mirror, the work of deception was ready to begin. The attendance of the magician upon his mirror was by no means necessary. He took his place along with the spectators within the magic circle. The images of the devils were all distinctly formed in the air immediately above the fire, but none of them could be seen by those within the circle. The moment, however, that perfumes were thrown into the fire to produce smoke, the first wreath of smoke that rose through the place of one or more of the images, would reflect them to the eyes of the spectator, and they could again disappear if the wreath was not followed by another. More and more images would be rendered visible as new wreaths of smoke arose, and the whole group would appear at once when the smoke was uniformly diffused over the place occupied by the images.

The "compositions which diffused noisome odours" were intended to intoxicate or stupify the spectators, so as to increase their liability to deception, or to add to the real phantasms which were before their eyes, others which were the offspring only of their own imaginations. It is not easy to gather from the description what parts of the exhibition were actually presented to the eyes of the spectators, and what parts of it were imagined by themselves. It is quite evident that

the boy, as well as Agnolino Gaddi, were so overpowered with terror that they fancied many things which they did not see; but when the boy declares that four armed giants, of an enormous stature, were threatening to break into the circle, he gives an accurate description of the effect that would be produced by pushing the figures nearer the mirror, and then magnifying their images, and causing them to advance towards the circle. Although Cellini declares that he was trembling with fear, yet it is quite evident that he was not entirely ignorant of the machinery which was at work; for in order to encourage the boy, who was almost dead with fear, he assured them that the devils were under their power, and that "what he saw was smoke and shadow."

Mr. Roscoe, from whose Life of Cellini the preceding description is taken, draws a similar conclusion from the consolatory words addressed to the boy, and states that they "confirm him in the belief, that the whole of these appearances, like a phantasmagoria, were merely the effects of a magic lantern produced on volumes of smoke from various kinds of burning wood." In drawing this conclusion, Mr. Roscoe has not adverted to the fact, that this exhibition took place about the middle of the 16th century, while the magic lantern was not invented by Kircher till towards the middle of the 17th century; Cellini having died in 1570, and Kircher having been born in 1601. There is no doubt that the effects described could be produced by this instrument, but we are not entitled to have recourse to any other means of explanation but those which were known to exist at the time of Cellini. If we suppose, however, that the necromancer either had a regular magic lantern, or that he had fitted up his concave mirror in a box containing the figures of his devils, and that this box with its lights was carried home with the party, we can easily account for the declaration of the boy, "that as they were going home to their houses in the quarter of Banchi, *two of the demons whom we had seen at the amphitheatre went on before us leaping and skipping, sometimes running upon the roofs of the houses, and sometimes upon the ground.*"

The introduction of the magic lantern as an optical instrument supplied the magicians of the 17th century with one of their most valuable tools. The use of the concave mirror, which does not appear to have been even put up into the form of an instrument, required a separate apartment, or at least that degree of concealment which it was difficult on ordinary occasions to command; but the magic lantern, containing in a small compass its lamp, its lenses, and its sliding figures, was peculiarly fitted for the itinerant conjuror, who had neither the means of providing a less portable and more extensive apparatus, nor the power of transporting and erecting it.

The magic lantern shown in the annexed figure consists of a dark lantern, AB, containing a lamp G, and a concave metallic mirror, MN, and it is so constructed that when the lamp is lighted not a ray of light is able to escape from it. Into the side of the lantern is fitted a double tube, CD, the outer half of which D is capable of moving within the other half. A large plano-convex lens C, is fixed at the inner end of the double tube, and a small convex lens D, at the outer end; and to the fixed tube CE, there is joined a groove EF, in which the sliders containing the painted objects are placed, and through which they can be moved. Each slider contains a series of figures or pictures painted on glass with highly transparent colours. The direct light of the lamp G, and the light reflected from the mirror MN, falling upon the illuminating lens C, is concentrated by it so as to throw a brilliant light upon the painting on the slider, and as this painting is in the conjugate focus of the convex lens D, a magnified image of it will be formed on a white wall or white cloth placed at PQ. If the lens D is brought nearer to EF, or to the picture, the distinct image will be more magnified, and will be formed at a greater distance from D, so that if there is any particular distance of the image which is more convenient than another, or any particular size of the object which we wish, it can be obtained by varying the distance of the lens D from EF.

Fig. 5.

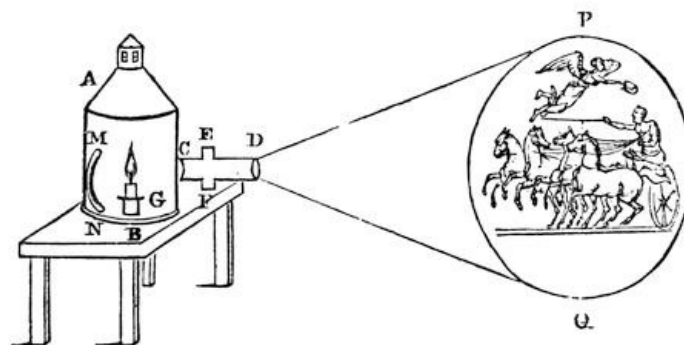

When the image is received on an opaque ground, as is commonly the case, the spectators are placed in the same room with the lantern; but, for the purposes of deception, it would be necessary to place the lantern in another apartment like the mirror in Fig. 4, and to throw the magnified pictures on a large plate of ground glass, or a transparent gauze screen, stretched across an opening EF, Fig. 4, made in the partition which separates the spectators from the exhibitor. The images might, like those of the concave mirror, be received upon wreaths of smoke. These images are of course always inverted in reference to the position of the painted objects; but in order to render them really erect, we have only to invert the sliders. The representations of the magic lantern never fail to excite a high degree of interest, even when exhibited with the ordinary apparatus; but by using double sliders, and varying their movements, very striking effects may be produced. A smith, for example, is made to hammer upon his anvil,—a figure is thrown into the attitude of terror by the introduction of a spectral apparition, and a tempest at sea is imitated, by having the sea on one slider, and the ships on other sliders, to

which an undulatory motion is communicated.

The magic lantern is susceptible of great improvement in the painting of the figures, and in the mechanism and combination of the sliders. A painted figure, which appears well executed to the unassisted eye, becomes a mere daub when magnified 50 or 100 times; and when we consider what kind of artists are employed in their execution, we need not wonder that this optical instrument has degenerated into a mere toy for the amusement of the young. Unless for public exhibition, the expense of exceedingly minute and spirited drawings could not be afforded; but I have no doubt that if such drawings were executed, a great part of the expense might be saved by engraving them on wood, and transferring their outline to the glass sliders.

A series of curious representations might be effected, by inserting glass plates containing suitable figures in a trough having two of its sides parallel, and made of plate glass. The trough must be introduced at EF, so that the figure on the glass is at the proper distance from the object lens D. When the trough is filled with water, or with any transparent fluid, the picture at PQ will be seen with the same distinctness as if the figure had been introduced by itself into the groove EF; but if any transparent fluid of a different density from water is mixed with it, so as to combine with it quickly or slowly, the appearance of the figure displayed at PQ will undergo singular changes. If spirits of wine, or any ardent spirit, are mixed with the water, so as to produce throughout its mass partial variations of density, the figure at PQ, will be as it were broken down into a thousand parts, and will recover its continuity and distinctness when the two fluids have combined. If a fluid of less density than water is laid gently upon the water, so as to mix with it gradually, and produce a regular diminution of density downwards—or if saline substances, soluble in water, are laid at the bottom of the trough, the density will diminish upwards, and the figure will undergo the most curious elongations and contractions. Analogous effects may be produced by the application of heat to the surface or sides of the trough, so that we may effect at the same time both an increase and a diminution in the density of the water, in consequence of which the magnified images will undergo the most remarkable transformations. It is not necessary to place the glass plate which contains the figure within the trough. It may be placed in front of it, and by thus creating as it were an atmosphere with local variations of density, we may exhibit the phenomena of the mirage and of looming, in which the inverted images of ships and other objects are seen in the air, as described in another letter.

The power of the magic lantern has been greatly extended by placing it on one side of the transparent screen of taffeta which receives the images, while the spectators are placed on the other side, and by making every part of the glass sliders opaque, excepting the part which forms the figures. Hence all the figures appear luminous on a black ground, and produce a much greater effect with the same degree of illumination. An exhibition depending on these principles was brought out by M. Philipstall in 1802, under the name of the *Phantasmagoria*, and when it was shown in London and Edinburgh, it produced the most impressive effects upon the spectators. The small theatre of exhibition was lighted only by one hanging lamp, the flame of which was drawn up into an opaque chimney or shade when the performance began. In this “darkness visible” the curtain rose and displayed a cave with skeletons and other terrific figures in relief upon its walls. The flickering light was then drawn up beneath its shroud, and the spectators in total darkness found themselves in the middle of thunder and lightning. A thin transparent screen had, unknown to the spectators, been let down after the disappearance of the light, and upon it the flashes of lightning and all the subsequent appearances were represented. This screen being half-way between the spectators and the cave which was first shown, and being itself invisible, prevented the observers from having any idea of the real distance of the figures, and gave them the entire character of aerial pictures. The thunder and lightning were followed by the figures of ghosts, skeletons, and known individuals, whose eyes and mouth were made to move by the shifting of combined sliders. After the first figure had been exhibited for a short time, it began to grow less and less, as if removed to a great distance, and at last vanished in a small cloud of light. Out of this same cloud the germ of another figure began to appear, and gradually grew larger and larger, and approached the spectators, till it attained its perfect development. In this manner the head of Dr. Franklin was transformed into a skull; figures which retired with the freshness of life came back in the form of skeletons, and the retiring skeletons returned in the drapery of flesh and blood.

The exhibition of these transmutations was followed by spectres, skeletons, and terrific figures, which, instead of receding and vanishing as before, suddenly advanced upon the spectators, becoming larger as they approached them, and finally vanished by appearing to sink into the ground. The effect of this part of the exhibition was naturally the most impressive. The spectators were not only surprised but agitated, and many of them were of opinion that they could have touched the figures. M. Robertson, at Paris, introduced along with his pictures the direct shadows of living objects, which imitated coarsely the appearance of those objects in a dark night or in moonlight.

All these phenomena were produced by varying the distance of the magic lantern AB, Fig 5, from the screen PQ, which remained fixed, and at the same time keeping the image upon the screen distinct, by increasing the distance of the lens D from the sliders in EF. When the lantern approached to PQ, the circle of light PQ, or the section of the cone of rays PDQ, gradually diminished, and resembled a small bright cloud, when D was close to the screen. At this time a new figure was put in, so that when the lantern receded from the screen, the old figure seemed to have been transformed into the new one. Although the figure was always at the same distance from the spectators, yet, owing to its gradual diminution in size, it necessarily appeared to be

retiring to a distance. When the magic lantern was withdrawn from PQ, and the lens D at the same time brought nearer to EF, the image in PQ gradually increased in size, and therefore seemed in the same proportion to be approaching the spectators.

Superior as this exhibition was to any representation that had been previously made by the magic lantern, it still laboured under several imperfections. The figures were poorly drawn, and in other respects not well executed, and no attempt whatever was made to remove the optical incongruity of the figures becoming more luminous when they retired from the observer, and more obscure when they approached to him. The variation of the distance of the lens D from the sliders in EF was not exactly adapted to the motion of the lantern to and from the screen, so that the outline of the figures was not equally distinct during their variations of magnitude.

Dr. Thomas Young suggested the arrangement shown in Fig. 6 for exhibiting the phantasmagoria.

Fig. 6.

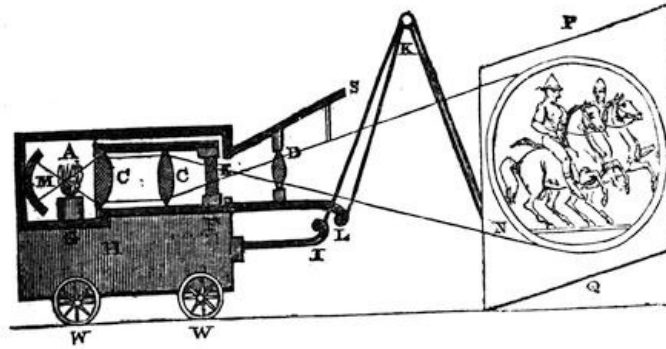

The magic lantern is mounted on a small car H, which runs on wheels WW. The direct light of the lamp G, and that reflected from the mirror M, is condensed by the illuminating lenses CC, upon the transparent figures in the opaque sliders at E, and the image of these figures is formed at PQ, by the object lens D. When the car H is drawn back on its wheels, the rod IK brings down the point K, and by means of the rod KL, pushes the lens D nearer to the sliders in EF, and when the car advances to PQ, the point K is raised, and the rod KL draws out the lens D from the slider, so that the image is always in the conjugate focus of D, and therefore distinctly painted on the screen. The rod KN must be equal in length to IK, and the point I must be twice the focal length of the lens D before the object, L being immediately under the focus of the lens. In order to diminish the brightness of the image when it grows small and appears remote, Dr. Young contrived that the support of the lens D should suffer a screen S to fall and intercept a part of the light. This method, however, has many disadvantages, and we are satisfied, that the only way of producing a variation in the light corresponding to the variation in the size of the image, is to use a single illuminating lens C, and to cause it to approach EF, and throw less light upon the figures when D is removed from EF, and to make C recede from EF when D approaches to it. The lens C should therefore be placed in a mean position, corresponding to a mean distance of the screen, and to the ordinary size of the figures, and should have the power of being removed from the slider EF, when a greater intensity of light is required for the images when they are rendered gigantic, and of being brought close to EF when the images are made small. The size of the lens C ought of course to be such that the section of its cone of rays at EF is equal to the size of the figure on the slider when C is at its greatest distance from the slider.

The method recommended by Dr. Young for pulling out and pushing in the object lens D, according as the lantern approaches to or recedes from the screen, is very ingenious and effective. It is, however, clumsy in itself, and the connexion of the levers with the screen, and their interposition between it and the lantern, must interfere with the operations of the exhibitor. It is, besides, suited only to short distances between the screen and the lantern; for when that distance is considerable, as it must sometimes require to be, the levers KL, KI, KT, would bend by the least strain, and become unfitted for their purpose. For these reasons the mechanism which adjusts the lens D should be moved by the axle of the front wheels, the tube which contains the lens should be kept at its greatest distance from EF by a slender spring, and should be pressed to its proper distance by the action of a spiral cam suited to the optical relation between the two conjugate focal distances of the lens.

Superior as the representations of the phantasmagoria are to those of the magic lantern, they are still liable to the defect which we have mentioned, namely, the necessary imperfection of the minute transparent figures when magnified. This defect cannot be remedied by employing the most skilful artists. Even Michael Angelo would have failed in executing a figure an inch long with transparent varnishes, when all its imperfections were to be magnified. In order, therefore, to perfect the art of representing phantasms, the objects must be living ones, and in place of chalky ill-drawn figures, mimicking humanity by the most absurd gesticulations, we shall have phantasms of the most perfect delineation, clothed in real drapery, and displaying all the movements of life. The apparatus by which such objects may be used, may be called the *catadioptrical phantasmagoria*, as it operates both by reflexion and refraction.

Fig. 7.

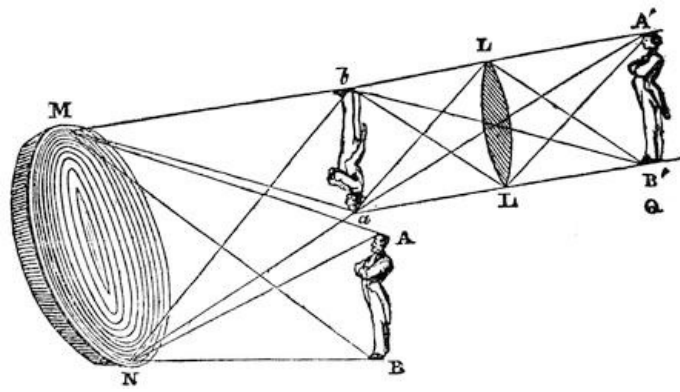

The combination of mirrors and lenses which seems best adapted for this purpose is shown in Fig. 7, where AB is a living figure placed before a large concave mirror MN, by means of which a diminished and inverted image of it is formed at *ab*. If PQ is the transparent screen upon which the image is to be shown to the spectators on the right hand of it, a large lens LL must be so placed before the image *ab*, as to form a distinct and erect picture of it at A'B' upon the screen. When the image A'B' is required to be the exact size of AB, the lens LL must magnify the small image *ab* as much as the mirror MN diminishes the figure AB. The living object AB, the mirror MN, and the lens LL, must all be placed in a moveable car for the purpose of producing the variations in the size of the phantasms, and the transformations of one figure into another. The contrivance for adjusting the lens LL, to give a distinct picture at different distances of the screen, will, of course, be required in the present apparatus. In order to give full effect to the phantasms, the living objects at AB will require to be illuminated in the strongest manner, and should always be dressed either in white or in very luminous colours; and, in order to give them relief, a black cloth should be stretched at some distance behind them. Many interesting effects might also be produced by introducing at AB fine paintings and busts.

It would lead us into too wide a field were we to detail the immense variety of resources which the science of optics furnishes for such exhibitions. One of these, however, is too useful to be passed without notice. If we interpose a prism with a small refracting angle between the image *ab*, Fig. 7, and the lens LL, the part of the figure immediately opposite to the prism will be as it were detached from the figure, and will be exhibited separately on the screen PQ. Let us suppose that this part is the head of the figure. It may be detached vertically, or lifted from the body as if it were cut off, or it may be detached downwards and placed on the breast as if the figure were deformed. In detaching the head vertically or laterally, an opaque screen must be applied to prevent any part of the head from being seen by rays which do not pass through the prism; but this and other practical details will soon occur to those who put the method to an experimental trial. The application of the prism is shown in Fig. 8, where *ab* is the inverted image formed by a concave mirror, ABC a prism with a small refracting angle BCA, placed between *ab* and the lens LL, *s* a small opaque screen, and AB the figure with its head detached. A hand may be made to grasp the hair of the head, and the aspect of death may be given to it, as if it had been newly cut off. Such a representation could be easily made, and the effect upon the spectators would be quite overpowering. The lifeless head might then be made to recover its vitality, and be safely replaced upon the figure. If the head A of the living object AB, Fig. 7, is covered with black cloth, the head of a person or of an animal placed above A might be set upon the shoulders of the figure AB by the refraction of a prism.

Fig. 8.

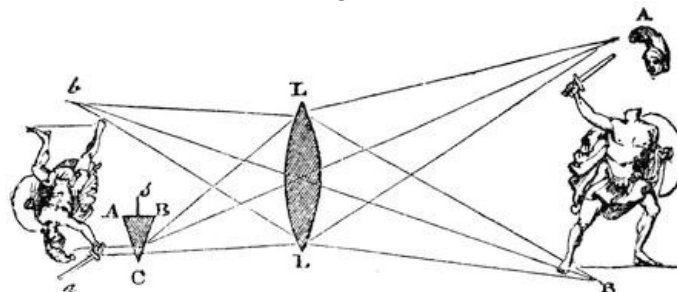

When the figure *ab*, Fig. 8, is of very small dimensions, as in the magic lantern, a small prism of glass would answer the purpose required of it; but in public exhibitions, where the image *ab* must be of a considerable size, if formed by a concave mirror, a very large prism would be necessary. This, however, though impracticable with solid glass, may be easily obtained by means of two large pieces of plate glass made into a prismatic vessel and filled with water. Two of the glasses of a carriage window would make a prism capable of doubling the whole of the bust of a living person placed as an object at AB, Fig. 7, so that two perfectly similar phantasms might be exhibited. In those cases where the images before the lens LL are small, they may be doubled and even tripled by interposing a well-prepared plate of calcareous spar, that is, crossed by a thin film. These images would possess the singular character of being oppositely coloured, and of changing their distances and their colours, by slight variations in the positions of the plate.⁸

In order to render the images which are formed by the glass and water prisms as perfect as

possible, it would be easy to make them achromatic, and the figures might be multiplied to any extent by using several prisms, having their refracting edges parallel, for the purpose of giving a similarity of position to all the images.

Fig. 9.

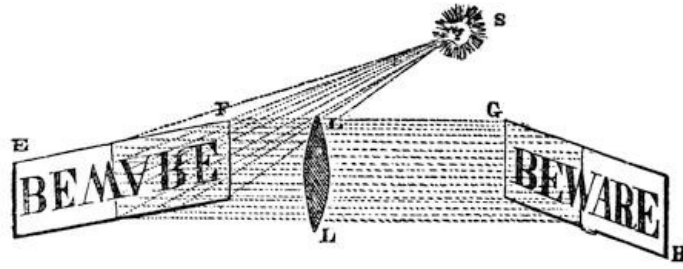

Among the instruments of natural magic which were in use at the revival of science, there was one invented by Kircher for exhibiting the mysterious hand-writing on the wall of an apartment, from which the magician and his apparatus were excluded. The annexed figure represents this apparatus as given by Schottus. The apartment in which the spectators are placed is between LL and GH, and there is an open window in the

side next LL, GH being the inside of the wall opposite to the window. Upon the face of the plane speculum EF are written the words to be introduced, and when a lens LL is placed at such a distance from the speculum, and of such a focal length, that the letters and the place of their representation are in its conjugate foci, a distinct image of the writing will be exhibited on the wall at GH. The letters on the speculum are of course inverted, as seen at EF, and when they are illuminated by the sun's rays S, as shown in the figure, a distinct image, as Schottus assures us, may be formed at the distance of 500 feet. In this experiment, the speculum is by no means necessary. If the letters are cut out of an opaque card, and illuminated by the light of the sky in the day, or by a lamp during night, their delineation on the wall would be equally distinct. In the daytime it would be necessary to place the letters at one end of a tube or oblong box, and the lens at the other end. As this deception is performed when the spectators are unprepared for any such exhibition, the warning written in luminous letters on the wall, or any word associated with the fate of the individual observer, could not fail to produce a singular effect upon his mind. The words might be magnified, diminished, multiplied, coloured, and obliterated, in a cloud of light, from which they might again reappear by the methods already described, as applicable to the magic lantern.

The art of forming aërial representations was a great desideratum among the opticians of the 17th century. Vitellio and others had made many unsuccessful attempts to produce such images, and the speculations of Lord Bacon on the subject are too curious to be withheld from the reader.

"It would be well bolted out," says he, "whether great refractions may not be made upon reflexions, as well as upon direct beams. For example, take an empty basin, put an angel or what you will into it; then go so far from the basin till you cannot see the angel, because it is not in a right line; then fill the basin with water, and you shall see it out of its place, because of the refraction. To proceed, therefore, put a looking-glass into a basin of water. I suppose you shall not see the image in a right line or at equal angles, but wide. I know not whether this experiment may not be extended, so as you might see the image and not the glass, which, for beauty and strangeness, were a fine proof, for then you should see the image like a spirit in the air. As, for example, if there be a cistern or pool of water, you shall place over against it the picture of the devil, or what you will, so as that you do not see the water. Then put a looking-glass in the water; now if you can see the devil's picture aside, not seeing the water, it would look like the devil indeed. They have an old tale in Oxford, that Friar Bacon walked between two steeples, which was thought to be done by glasses, when he walked upon the ground."

Fig. 10.

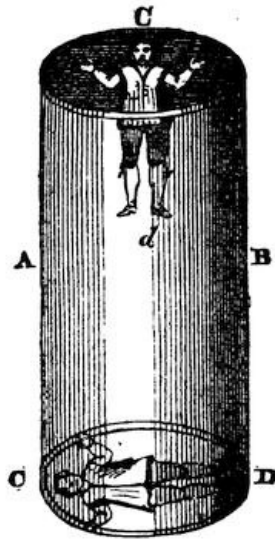

Kircher also devoted himself to the production of such images, and he has given in the annexed figure his method of producing them. At the bottom of a polished cylindrical vessel AB, he placed a figure CD, which we presume must have been highly illuminated from below, and to the spectators who looked into the vessel in an oblique direction there was exhibited an image placed vertically in the air as if it were ascending at the mouth of the vessel. Kircher assures us that he once exhibited in this manner a representation of the Ascension of our Saviour, and that the images were so perfect that the spectators could not be persuaded, till they had attempted to handle them, that they were not real substances. Although Kircher does not mention it, yet it is manifest that the original figure AB must have been a deformed or anamorphous drawing, in order to give a reflected image of just proportions. We doubt, indeed, if the representation or the figure was ever exhibited. It is entirely incompatible with the laws of reflexion.

Fig. 11.

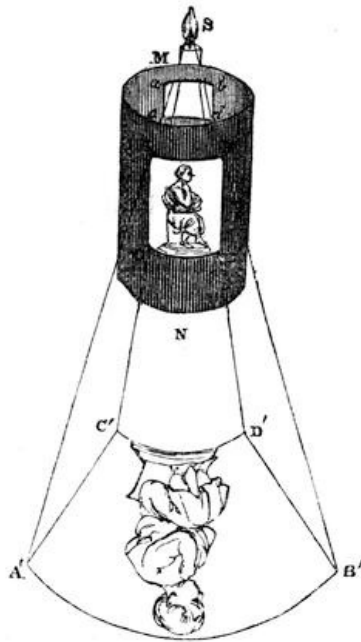

Among the ingenious and beautiful deceptions of the 17th century, we must enumerate that of the re-formation of distorted pictures by reflexion from cylindrical and conical mirrors. In these representations, the original image from which a perfect picture is produced is often so completely distorted, that the eye cannot trace in it the resemblance to any regular figure, and the greatest degree of wonder is of course excited, whether the original image is concealed or exposed to view. These distorted pictures may be drawn by strict geometrical rules; but I have shown in Fig. 11 a simple and practical method of executing them. Let MN be an accurate cylinder made of tin-plate or of thick pasteboard. Out of the farther side of it cut a small aperture *abcd*; and out of the nearer side cut a larger one ABCD, the size of the picture to be distorted. Having perforated the outline of the picture with small holes, place it on the opening ABCD, so that its surface may be cylindrical. Let a candle or a bright luminous object, the smaller the better, be placed at S, as far behind the picture ABCD as the eye is afterwards to be placed before it, and the light passing through the small holes will represent on a horizontal plane a distorted image of the picture A'B'C'D', which, when sketched in outline with a pencil, and shaded or coloured, will be ready for use. If we now substitute a polished cylindrical mirror of the same size in place of MN, then the distorted picture, when laid horizontally at A'B'C'D', will be restored to its original state when seen by reflexion at ABCD in the polished mirror. It would be an improvement on this method to place at ABCD a thin and flexible plate of transparent mica, having drawn upon it with a sharp point, or painted upon it, the figure required. The projected

image of this figure at A'B'C'D' may then be accurately copied.

The effect of a cylindrical mirror is shown in Fig. 12, which is copied from an old one which we have seen in use.

Fig. 12.

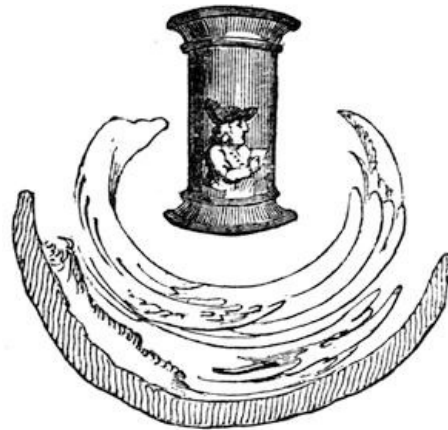

The method above described is equally applicable to concave cylindrical mirrors, and to those of a conical form; and it may also be applied to mirrors of variable curvature, which produce different kinds of distortions from different parts of their surfaces.

Fig. 13.

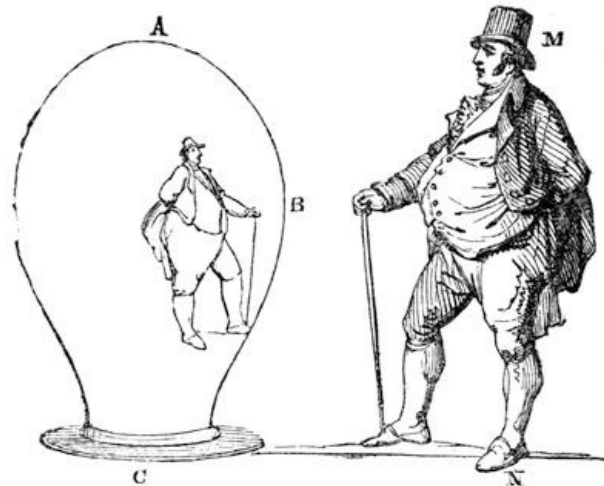

By employing a mirror whose surface has a variable curvature like ABC, Fig. 13, we obtain an instrument for producing an endless variety of caricatures, all of which are characterised by their resemblance to the original. If a figure MN is placed before such a mirror, it will of course appear distorted and caricatured; but even if the figure takes different distances and positions, the variations which the image undergoes are neither sufficiently numerous nor remarkable to afford much amusement. But if the figure MN is very near the mirror, so that new distortions are produced by the different distances of its different parts from the mirror, the most singular caricatures may be exhibited. If the figure, for example, bends forwards his head and the upper part of his body, they will swell in size, leaving his lower extremities short and slender. If it draws back the upper part of the body and advances the limbs, the opposite effect will take place. In like manner different sides of the head, the right or the left side of it, the brow or the chin, may be swelled and contracted at pleasure. By stretching out the arms before the body they become like those of an orang-outang, and by drawing them back they dwindle into half their regular size. All these effects, which depend chiefly on the agility and skill of the performer, may be greatly increased by suitable distortions in his own features and figure. The family likeness, which is of course never lost in all the variety of figures which are thus produced, adds greatly to the interest of the exhibition; and we have seen individuals so annoyed at recognising their own likeness in the hideous forms of humanity which were thus delineated, that they could not be brought to contemplate them a second time. If the figure is inanimate, like the small cast of a statue, the effect is very curious, as the swelling and contracting of the parts and the sudden change of expression give a sort of appearance of vitality to the image. The inflexibility of such a figure, however, is unfavourable to its transformation into caricatures.

Interesting as these metamorphoses are, they lose in the simplicity of the experiment much of the wonder which they could not fail to excite if exhibited on a great scale, where the performer is invisible, and where it is practicable to give an aerial representation of the caricatured figures. This may be done by means of the apparatus shown in Fig. 7,⁹ where we may suppose AB to be the reduced image seen in the reflecting surface ABC, Fig. 13.¹⁰ By bringing this image nearer the mirror MM, Fig. 7, a magnified and inverted image of it may be formed at *ab*, of such a magnitude as to give the last image in PQ the same size as life. Owing to the loss of light by the

two reflexions, a very powerful illumination would be requisite for the original figure. If such an exhibition were well got up, the effect of it would be very striking.

LETTER V.

Miscellaneous optical illusions—Conversion of cameos into intaglios, or elevations into depressions, and the reverse—Explanation of this class of deceptions—Singular effects of illumination with light of one simple colour—Lamps for producing homogeneous yellow light—Methods of increasing the effect of this exhibition—Method of reading the inscription of coins in the dark—Art of deciphering the effaced inscription of coins—Explanation of these singular effects—Apparent motion of the eyes in portraits—Remarkable examples of this—Apparent motion of the features of a portrait, when the eyes are made to move—Remarkable experiment of breathing light and darkness.

In the preceding letter I have given an account of the most important instruments of Natural Magic which depend on optical principles: but there still remain several miscellaneous phenomena on which the stamp of the marvellous is deeply impressed, and the study of which is pregnant with instruction and amusement.

One of the most curious of these is that false perception in vision by which we conceive depressions to be elevations, and elevations depressions, or by which intaglios are converted into cameos, and cameos into intaglios. This curious fact seems to have been first observed at one of the early meetings of the Royal Society of London, when one of the members, in looking at a guinea through a compound microscope of new construction, was surprised to see the head upon the coin depressed, while other members could only see it embossed as it really was.

While using telescopes and compound microscopes, Dr. Gmelin of Wurtemberg observed the same fact. The protuberant parts of objects appeared to him depressed, and the depressed parts protuberant: but what perplexed him extremely, this illusion took place at some times and not at others, in some experiments and not in others, and appeared to some eyes and not to others.

After making a great number of experiments, Dr. Gmelin is said to have constantly observed the following effects: Whenever he viewed any object rising upon a plane of any colour whatever, provided it was neither white nor shining, and provided the eye and the optical tube were directly opposite to it, the elevated parts appeared depressed, and the depressed parts elevated. This happened when he was viewing a seal, and as often as he held the tube of the telescope perpendicularly, and applied it in such a manner that its whole surface almost covered the last glass of the tube. The same effect was produced when a compound microscope was used. When the object hung perpendicularly, from a plane, and the tube was supported horizontally and directly opposite to it, the illusion also took place, and the appearance was not altered when the object hung obliquely and even horizontally. Dr. Gmelin is said to have at last discovered a method of preventing this illusion, which was by looking, not towards the centre of the convexity, but at first to the edges of it only, and then gradually taking in the whole. "But why these things should so happen, he did not pretend to determine."

Fig. 14.



The best method of observing this deception is to view the engraved seal of a watch with the eyepiece of an achromatic telescope, or with a compound microscope, or any combination of lenses which inverts the objects that are viewed through it.¹¹ The depression in the seal will immediately appear an elevation, like the wax impression which is taken from it; and though we know it to be hollow, and feel its concavity with the point of our finger, the illusion is so strong that it continues to appear a protuberance. The cause of this will be understood from Fig. 14, where S is the window of the apartment, or the light which illuminates the *hollow* seal LR, whose shaded side is of course on the same side L with the light. If we now invert the seal, with one or more lenses, so that it may look in the opposite direction, it will appear to the eye as in Fig. 15, with the shaded side L farthest from the window. But as we know that the window is still on our left hand, and that the light falls in the direction RL, and as everybody with its shaded side farthest from the light must necessarily be convex or protuberant, we immediately believe that the hollow seal is now a cameo or bas-relief. The proof which the eye thus receives of the seal being raised, overcomes the evidence of its being hollow, derived from our actual knowledge, and from the sense of touch. In this experiment the deception takes place from our knowing the real direction of the light which falls upon the seal; for if the place of the window, with respect to the seal, had been inverted as well as the seal itself, the illusion could not have taken place.

Fig. 15.



Fig. 16.



In order to explain this better, let us suppose the seal LR, Fig. 14, to be illuminated with a candle S, the place of which we can change at pleasure. If we invert LR, it will rise into a cameo, as in Fig. 15; and if we then place another candle S on the other side of it, as in Fig. 16, the hollow seal will be equally illuminated on all sides, and it will sink down into a cavity or intaglio. If the two candles do not illuminate the seal equally, or if any accidental circumstance produces a belief that the light is wholly or principally on one side, the mind will entertain a corresponding opinion respecting the state of the seal, regarding it as a hollow if it believes the light to come wholly or principally from the right hand, and as a cameo if it believes the light to come from the left hand.

If we use a small telescope to invert the seal, and if we cover up all the candle but the flame, and arrange the experiment so that the candle may be inverted along with the image, the seal will still retain its concavity, because the shadow is still on the same side with the illuminating body.

If we make the same experiments with the raised impression of the seal taken upon wax, we shall observe the very same phenomena, the seal being depressed when it alone is inverted, and retaining its convexity when the light is inverted along with it.

The illusion, therefore, under our consideration is the result of an operation of our own minds, whereby we judge of the forms of bodies by the knowledge we have acquired of light and shadow. Hence the illusion depends on the accuracy and extent of our knowledge on this subject; and while some persons are under its influence, others are entirely insensible to it. When the seal or hollow cavity is not polished, but ground, and the surface round it of uniform colour and smoothness, almost every person, whether young or old, learned or ignorant, will be subject to the illusion; because the youngest and the most careless observers cannot but know that the shadow of a hollow is always on the side next the light, and the shadow of a protuberance on the side opposite to the light; but if the object is the raised impression of a seal upon wax, I have found that, when inverted, it still seemed raised to the three youngest of six persons, while the three eldest were subject to the deception.

Fig. 17.

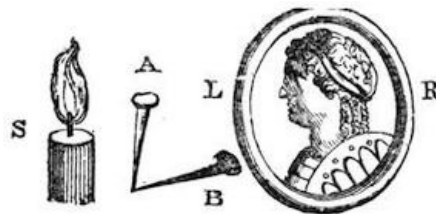

This illusion may be dissipated by a process of reasoning arising from the introduction of a new circumstance in the experiment. Thus, let RL, Fig. 17, be the inverted seal, which consequently appears raised, and let an opaque and unpolished pin, A, be placed on one side of the seal. Its shadow will be of course opposite the candle as at B. In this case the seal, which had become a cameo by its inversion, will now sink down into a cavity by the introduction of the pin and its shadow; for as the pin and its shadow are inverted, as shown in Fig. 18, while the candle retains its place, the shadow of the pin falling in the direction AB is a stronger proof to the eye that the light is coming from the right hand, than the actual knowledge of the candle being on the left hand, and therefore the cameo necessarily sinks into a cavity, or the shadow is now on the same side as the light. This experiment will explain to us why on some occasions an acute observer will elude the deception, while every other person is subject to it. Let us suppose that a particle of dust, or a little bit of wax, capable of giving a shadow, is adhering to the surface of the seal, an ordinary observer will take no notice of this, or if he does, he will probably not make it a subject of consideration, and will therefore see the head on the seal raised into a cameo; but the attentive observer, noticing the little protuberance, and observing that its shadow lies to the left of it, will instantly infer that the light comes in that direction, and will still see the seal hollow.

Fig. 18.



I have already mentioned that in some cases even the sense of touch does not correct the erroneous perception. We of course feel that the part of the hollow on which the finger is placed

is actually hollow; but if we look at the other part of the hollow it will still appear raised.

By using two candles yielding different degrees of light, and thus giving an uncertainty to the direction of the light, we may weaken the illusion in any degree we choose, so as to overpower it by touch, or by a process of reasoning.

I have had occasion to observe a series of analogous phenomena arising from the same cause, but produced without any instrument for inverting the object. If AB, for example, is a plate of mother-of-pearl, and LR a circular or any other cavity (Fig. 19) ground or turned in it, then if this cavity is illuminated by a candle or a window at S, in place of there being a shadow of the margin L of the hollow next the light, as there would have been had the body been opaque, a quantity of bright refracted light will appear where there would have been a shadow, and the rest of the cavity will be comparatively obscure, as if it were in shade. The necessary consequence of this is, that the cavity will appear as an elevation when seen only by the naked eye, as it is only an elevated surface that could have its most luminous side at L.

Fig. 19.

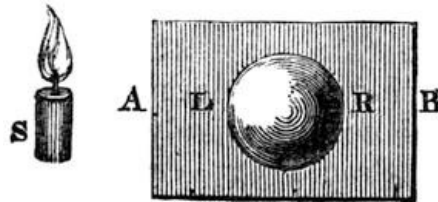

Similar illusions take place in certain pieces of polished wood, chalcedony, and mother-of-pearl, where the surface is perfectly smooth. This arises from there being at that place a knot or growth, or nodule, of different transparency from the surrounding mass, and the cause of it will be understood from Fig. 20. Let $m o$ be the surface of a mahogany table, $m A o B$ a section of the table, and $m n o$ a section of a knot more transparent than the rest of the mass. Owing to the transparency of the thin edge at o , opposite to the candle S, the side o is illuminated, while the rest of the knot is comparatively dark, so that, on the principles already explained, the spot $m n o$ appears to be a hollow in the table. From this cause arises the appearance of dimples in certain plates of chalcedony, called hammered chalcedony, owing to its having the look of being dimpled with a hammer. The surface on which these cavities are seen is a section of small spherical aggregations of siliceous matter, which exhibit the same phenomena as the cavities in wood. Mother-of-pearl presents the very same phenomena, and it is indeed so common in this substance, that it is nearly impossible to find a mother-of-pearl button or counter which seems to have its surface flat, although they are perfectly so when examined by the touch. Owing to the different refraction of the incident light by the different growths of the shell cut in different directions by the artificial surface, like the annual growth of wood in a dressed plank, the surface has necessarily an unequal and undulating appearance.

Fig. 20.

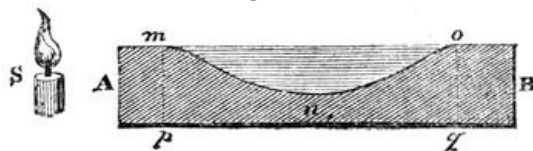

Among the wonders of science there are perhaps none more surprising than the effects produced upon coloured objects by illuminating them with homogeneous light, or light of one colour. The light which emanates from the sun, and by which all the objects of the material world are exhibited to us, is composed of three different colours, *red*, *yellow*, and *blue*, by the mixture of which in different proportions all the various hues of nature may be produced. These three colours, when mixed in the proportion in which they occur in the sun's rays, compose a purely white light; but if any body on which this white light falls shall absorb, or stop, or detain within its substance any part of any one or more of these simple colours, it will appear to the eye of that colour which arises from the mixture of all the rays which it does not absorb, or of that colour which white light would have if deprived of the colours which are absorbed. Scarlet cloth, for example, absorbs most of the blue rays and many of the yellow, and hence appears *red*. Yellow cloth absorbs most of the blue and many of the red rays, and therefore appears yellow; and blue cloth absorbs most of the yellow and red rays. If we were to illuminate the *scarlet* cloth with pure and unmixed *yellow* light, it would appear *yellow*, because the scarlet cloth does not absorb all the yellow rays, but reflects some of them; and if we illuminate *blue* cloth with yellow light, it will appear nearly *black*, because it absorbs all the yellow light, and reflects almost none of it. But whatever be the nature and colour of the bodies on which the yellow light falls, the light which it reflects must be yellow, for no other light falls upon them, and those which are not capable of reflecting yellow light must appear absolutely black, however brilliant be their colour in the light of day.

Fig. 21.

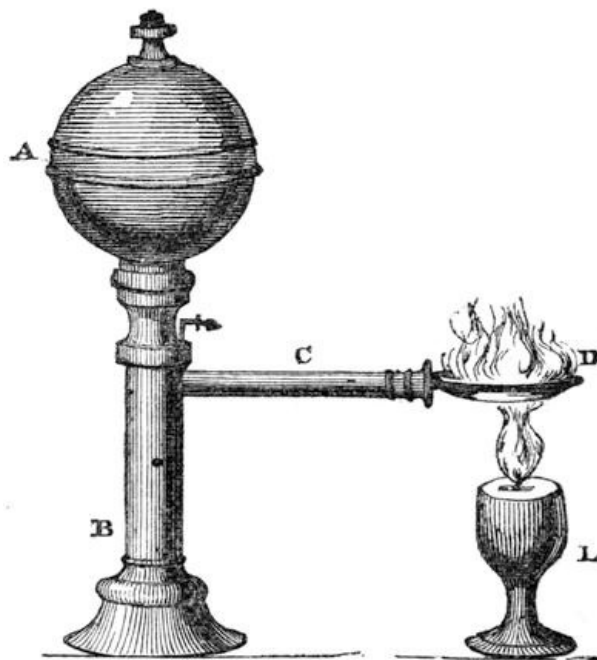

As the methods now discovered of producing yellow light in abundance were not known to the ancient conjurors, nor even to those of later times, they have never availed themselves of this valuable resource. It has been long known that salt thrown into the wick of a flame produces yellow light, but this light is mixed with blue and green rays, and is, besides, so small in quantity, that it illuminates objects only that are in the immediate vicinity of the flame. A method which I have found capable of producing it in abundance is shown in Fig. 21, where AB is a lamp, containing at A a large quantity of alcohol and water, or ardent spirits, which gradually descends into a platina or metallic cup D. This cup is strongly heated by a spirit-lamp L, inclosed in a dark lantern, and when the diluted alcohol in D is inflamed, it will burn with a fierce and powerful yellow flame. If the flame should not be perfectly yellow, owing to an excess of alcohol, a proportion of salt thrown into the cup will answer the same purpose as a further dilution of the alcohol.¹²

A monochromatic lamp for producing yellow light may be constructed most effectually, by employing a portable gas lamp, containing compressed oil gas. If we allow the gas to escape in a copious stream, and set it on fire, it will form an explosive mixture with the atmospheric air, and will no longer burn with a white flame, but will emit a bluish and reddish light. The force of the issuing gas, or any accidental current of air, is capable of blowing out this flame, so that it is necessary to have a contrivance for sustaining it. The method which I used for this purpose is shown in Fig. 22. A small gas tube *a b c*, arising from the main burner MN of the gas lamp PQ, terminates above the burner, and has a short tube *d e*, moveable up and down within it, so as to be gas-tight. This tube *d e*, closed at *e*, communicates with the hollow ring *f g*, in the inside of which four apertures are perforated in such a manner as to throw their jets of gas to the apex of a cone, of which *f g* is the base. When we cause the gas to flow from the burner M, by opening the main cock A, it will rush into the tube *a b c d*, and issue in small flames at the four holes in the ring *f g*. The size of these flames is regulated by the cock *b*. The inflammation, therefore, of the ignited gas will be sustained by these four subsidiary flames through which it passes, independent of any agitation of the air, or of the force with which it issues from the burner. On a projecting arm *e h*, carrying a ring *h*, I fixed a broad collar, made of coarse cotton wick, which had been previously soaked in a saturated solution of common salt. When the gas was allowed to escape at M, with such force as to produce a long and broad column of an explosive mixture of gas and atmospheric air, the bluish flame occasioned by the explosion passes through the salted collar, and is converted by it into a mass of homogeneous yellow light. This collar will last a long time without any fresh supply of salt, so that the gas lamp will yield a permanent monochromatic yellow flame, which will last as long as there is gas in the reservoir. In place of a collar of cotton wick, a hollow cylinder of sponge, with numerous projecting tufts, may be used, or a collar may be similarly constructed with asbestos cloth, and, if thought necessary, it might be supplied with a saline solution from a capillary fountain.

Fig. 22.

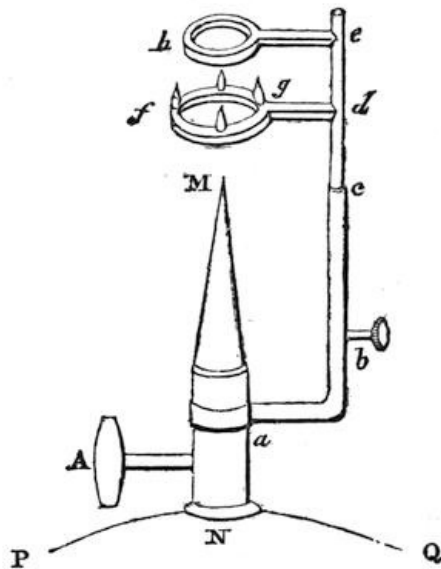

Having thus obtained the means of illuminating any apartment with yellow light, let the exhibition be made in a room with furniture of various bright colours, with oil or water-coloured paintings on the wall. The party which is to witness the experiment should be dressed in a diversity of the gayest colours; and the brightest-coloured flowers and highly-coloured drawings should be placed on the tables. The room being at first lighted with ordinary lights, the bright and gay colours of everything that it contains will be finely displayed. If the white lights are now suddenly extinguished, and the yellow lamps lighted, the most appalling metamorphosis will be exhibited. The astonished individuals will no longer be able to recognize each other. All the furniture in the room, and all the objects which it contains, will exhibit only one colour. The flowers will lose their hues. The paintings and drawings will appear as if they were executed in China ink; and the gayest dresses, the brightest scarlets, the purest lilacs, the richest blues, and the most vivid greens, will all be converted into one monotonous yellow. The complexions of the parties, too, will suffer a corresponding change. One pallid, death-like yellow,

--- like the unnatural hue
Which autumn paints upon the perished leaf,

will envelope the young and the old, and the sallow faces will alone escape from the metamorphosis. Each individual derives merriment from the cadaverous appearance of his neighbour, without being sensible that he is himself one of the ghostly assemblage.

If, in the midst of the astonishment which is thus created, the white lights are restored at one end of the room, while the yellow lights are taken to the other end, one side of the dress of every person, namely, that next the white light, will be restored to its original colours, while the other side will retain its yellow hue. One cheek will appear in a state of health and colour, while the other retains the paleness of death; and, as the individuals change their position, they will exhibit the most extraordinary transformations of colour.

If, when all the lights are yellow, beams of white light are transmitted through a number of holes, like those in a sieve, each luminous spot will restore the colour of the dress or furniture upon which it falls, and the nankeen family will appear all mottled over with every variety of tint. If a magic lantern is employed to throw upon the walls or upon the dresses of the company luminous figures of flowers or animals, the dresses will be painted with these figures in the real colour of the dress itself. Those alone who appeared in yellow, and with yellow complexions, will, to a great degree, escape all these singular changes.

If red and blue light could be produced with the same facility and in the same abundance as yellow light, the illumination of the apartment with these lights in succession would add to the variety and wonder of the exhibition. The red light might perhaps be procured in sufficient quantity from the nitrate and other salts of strontian; but it would be difficult to obtain a blue flame of sufficient intensity for the suitable illumination of a large room. Brilliant white lights, however, might be used, having for screens glass troughs containing a mass one or two inches thick of a solution of the ammoniacal carbonate of copper. This solution absorbs all the rays of the spectrum but the blue, and the intensity of the blue light thus produced would increase in the same proportion as the white light employed.

Amongst the numerous experiments with which science astonishes and sometimes even strikes terror into the ignorant, there is none more calculated to produce this effect than that of displaying to the eye in absolute darkness the legend or inscription upon a coin. To do this, take a silver coin (I have always used an old one), and after polishing the surface as much as possible, make the parts of it which are raised rough by the action of an acid, the parts not raised, or those which are to be rendered darkest, retaining their polish. If the coin thus prepared is placed upon a mass of red-hot iron, and removed into a dark room, the inscription upon it will become less luminous than the rest, so that it may be distinctly read by the spectator. The mass of red-hot iron should be concealed from the observer's eye, both for the purpose of rendering the eye fitter for observing the effect, and of removing all doubt that the inscription is really read in the dark,

that is, without receiving any light, direct or reflected, from any other body. If, in place of polishing the depressed parts and roughening its raised parts, we make the raised parts polished and roughen the depressed parts, the inscription will now be less luminous than the depressed parts, and we shall still be able to read it, from its being as it were written in black letters on a white ground. The first time I made this experiment, without being aware of what would be the result, I used a French shilling of Louis XV., and I was not a little surprised to observe upon its surface, in black letters, the inscription BENEDICTUM SIT NOMEN DEI.

The most surprising form of this experiment is when we use a coin from which the inscription has been either wholly obliterated, or obliterated in such a degree as to be illegible. When such a coin is laid upon the red-hot iron, the letters and figures become oxidated, and the film of oxide radiating more powerfully than the rest of the coin, the illegible inscription may be now distinctly read, to the great surprise of the observer, who had examined the blank surface of the coin previous to its being placed upon the hot iron. The different appearances of the same coin, according as the raised parts are polished or roughened, are shown in Fig. 23 and 24.

In order to explain the cause of these remarkable effects, we must notice a method which has been long known, though never explained, of deciphering the inscriptions on worn-out coins. This is done by merely placing the coin upon a hot iron; an oxidation takes place over the whole surface of the coin, the film of oxide changing its tint with the intensity or continuance of the heat. The parts, however, where the letters of the inscription had existed, oxidate at a different rate from the surrounding parts, so that these letters exhibit their shape, and become legible in consequence of the film of oxide which covers them having a different thickness, and therefore reflecting a different tint from that of the adjacent parts. The tints thus developed sometimes pass through many orders of brilliant colours, particularly *pink* and *green*, and settle in a bronze, and sometimes a black tint, resting upon the inscription alone. In some cases the tint left on the trace of the letters is so very faint that it can just be seen, and may be entirely removed by a slight rub of the finger.

Fig. 23.



Fig. 24.



When the experiment is often repeated with the same coin, and the oxidations successively removed after each experiment, the film of oxide continues to diminish, and at last ceases to make its appearance. It recovers the property, however, in the course of time. When the coin is put upon the hot iron, and consequently when the oxidation is the greatest, a considerable smoke arises from the coin, and this diminishes like the film of oxide by frequent repetition. A coin which had ceased to emit this smoke, smoked slightly after having been exposed twelve hours to the air. I have found, from numerous trials, that it is always the raised parts of the coin, and in modern coins the elevated ledge round the inscription, that become first oxidated. In an English shilling of 1816, this ledge exhibited a brilliant yellow tint before it appeared on any other part of the coin.

If we use a uniform and homogeneous disc of silver that has never been hammered or compressed, its surface will oxidate equally, provided all its parts are equally heated. In the process of converting this disc into a coin, the *sunk* parts have obviously been *most compressed* by the prominent parts of the die, and the *elevated* parts *least compressed*, the metal being in the latter left as it were in its natural state. The raised letters and figures on a coin have therefore less density than the other parts, and these parts oxidate sooner or at a lower temperature. When the letters of the legend are worn off by friction, the parts immediately below them have also less

density than the surrounding metal, and the site as it were of the letters therefore receives from heat a degree of oxidation, and a colour different from that of the surrounding surface. Hence we obtain an explanation of the revival of the invisible letters by oxidation.

The same influence of difference of density may be observed in the beautiful oxidations which are produced on the surface of highly-polished steel, heated in contact with air, at temperatures between 430° and 630° of Fahrenheit.¹³ When the steel has hard portions called pins by the workmen, the uniform tint of the film of oxide stops near these hard portions, which always exhibit colours different from those of the rest of the mass. These parts, on account of their increased density, absorb the oxygen of atmospheric air less copiously than the surrounding portions. Hence we see the cause why steel expanded by heat absorbs oxygen, which when united with the metal, forms the coloured superficial film. As the heat increases, a greater quantity of oxygen is absorbed, and the film increases in thickness.

These observations enable us to explain the legibility of inscriptions in the dark, whether the coin is in a perfect state, or the letters of it worn off. All *black* or *rough* surfaces radiate light more copiously than *polished* or *smooth* surfaces, and hence the inscription is *luminous* when it is *rough*, and *obscure* when it is polished, and the letters covered with black oxide are more luminous than the adjacent parts, on account of the superior radiation of light by the black oxide which covers them.

By the means now described, invisible writing might be conveyed by impressing it upon a metallic surface, and afterwards erasing it by grinding and polishing that surface perfectly smooth. When exposed to a proper degree of heat, the secret would display itself written in oxidated letters. Many amusing experiments might be made upon the same principle.

A series of curious and sometimes alarming deceptions, arises from the representation of objects in perspective upon a plane surface. One of the most interesting of these depends on the principles which regulate the apparent direction of the eyes in a portrait. Dr. Wollaston has thought this subject of sufficient importance to be treated at some length in the Philosophical Transactions. When we look at any person we direct to them both our face and our eyes, and in this position the circular iris will be in the middle of the white of the eye ball, or, what is the same thing, there will be the same quantity of white on each side of the iris. If the eyes are now moved to either side, while the head remains fixed, we shall readily judge of the change of their direction by the greater or less quantity of white on each side of the iris. This test, however, accurate as it is, enables us only to estimate the extent to which the eyes deviate in direction from the direction of the face to which they belong. But their direction in reference to the person who views them is entirely a different matter; and Dr. Wollaston is of opinion, that we are not guided by the eyes alone, but are unconsciously aided by the concurrent position of the entire face.

Fig. 26.



If a skilful painter draws a pair of eyes with great correctness directed to the spectator, and deviating from the general position of the face as much as is usual in good portraits, it is very difficult to determine their direction, and they will appear to have different directions to different persons. But what is very curious, Dr. Wollaston has shown that the same pair of eyes may be made to direct themselves either to or from the spectator by the addition of other features in which the position of the face is changed. Thus, in Fig. 25, the pair of eyes are looking intently at the spectator, and the face has a corresponding direction; but when we cover up the face in Fig. 26 with the face in Fig. 26, which looks to the right, the eyes change their direction, and look to the right also. In like manner, eyes drawn originally to look a little to the right or the left of the spectator, may be made to look directly at him by adding suitable features.

Fig. 25.



The nose is obviously the principal feature which produces this change of direction, as it is more subject to change of perspective than any of the other features; but Dr. Wollaston has shown by a very accurate experiment, that even a small portion of the nose introduced with the features will carry the eyes along with it. He obtained four exact copies of the same pair of eyes looking at the spectator, by transferring them upon copper from a steel plate, and having added to each of two pair of them a nose, in one case directed to the right, and in the other to the left, and to each of the other two pair a very small portion of the upper part of the nose, all the four pair of eyes lost their front direction, and looked to the right or to the left, according to the direction of the nose, or of the portion of it which was added.

But the effect thus produced is not limited, as Dr. Wollaston remarks, to the mere change in the direction of the eyes, "for a total difference of character may be given to the same eyes by a due representation of the other features. A lost look of devout abstraction in an uplifted countenance, may be exchanged for an appearance of inquisitive archness in the leer of a younger face turned downwards and obliquely towards the opposite side," as in Fig. 27, 28. This, however, is perhaps not an exact expression of the fact. The new character which is said to be given to the eyes is given only to the eyes in combination with the new features, or, what is probably more correct, the inquisitive archness is in the other features, and the eye does not belie it.

Dr. Wollaston has not noticed the converse of these illusions, in which a change of direction is given to fixed features by a change in the direction of the eyes. This effect is finely seen in some magic lantern sliders, where a pair of eyes is made to move in the head of a figure, which invariably follows the motion of the eyeballs.

Fig. 28.



Fig. 27.



Having thus determined the influence which the general perspective of the face has upon the apparent direction of the eyes in a portrait, Dr. Wollaston applies it to the explanation of the well-known fact, that when the eyes of a portrait look at a spectator in front of it they will follow him, and appear to look at him in every other direction. This curious fact, which has received less consideration than it merits, has been often skilfully employed by the novelist, in alarming the fears or exciting the courage of his hero. On returning to the hall of his ancestors, his attention is powerfully fixed on the grim portraits which surround him. The parts which they have respectively performed in the family history rise to his mind: his own actions, whether good or evil, are called up in contrast, and as the preserver or the destroyer of his line, he stands, as it were, in judgment before them. His imagination, thus excited by conflicting feelings, transfers a sort of vitality to the canvas, and if the personages do not "start from their frames," they will at least bend upon him their frowns or their approbation. It is in vain that he tries to evade their scrutiny. Wherever he goes their eyes eagerly pursue him; they will seem even to look at him over their shoulders, and he will find it impossible to shun their gaze but by quitting the apartment.

As the spectator in this case changes his position in a horizontal plane, the effect which we have described is accompanied by an apparent diminution in the breadth of the human face, from only seven or eight inches till it disappears at a great obliquity. In moving, therefore, from a front view to the most oblique view of the face, the change in its apparent breadth is so slow that the apparent motion of the head of the figure is scarcely recognized as it follows the spectator. But if the perspective figure has a great breadth in a horizontal plane, such as a soldier firing his musket, an artilleryman his piece of ordnance, a bowman drawing his bow, or a lancer pushing his spear, the apparent breadth of the figure will vary from five to six feet or upwards till it disappears, and therefore the change of apparent magnitude is sufficiently rapid to give the figure the dreaded appearance of turning round, and following the spectator. One of the best examples of this must have been often observed in the foreshortened figure of a dead body lying horizontally, which has the appearance of following the observer with great rapidity, and turning round upon the head as the centre of motion.

The cause of this phenomenon is easily explained. Let us suppose a portrait with its face and its eyes directed straight in front, so as to look at the spectator. Let a straight line be drawn through the tip of the nose and half way between the eyes, which we shall call the middle line. On each side of this middle line there will be the same breadth of head, of cheek, of chin, and of neck, and each iris will be in the middle of the white of the eye. If we now go to one side, the apparent horizontal breadth of every part of the head and face will be diminished, but the parts on each side of the middle line will be diminished equally, and at any position, however oblique, there will be the same breadth of face on each side of the middle line, and the iris will be in the centre of the white of the eyeball, so that the portrait preserves all the characters of a figure looking at the spectator, and must necessarily do so wherever he stands.

This explanation might be illustrated by a picture which represents three artillerymen, each firing a piece of ordnance in parallel directions. Let the gun of the middle one be pointed accurately to the eye of the spectator, so that he sees neither its right side nor its left, nor its upper nor its under side, but directly down its muzzle, so that if there was an opening in the breech he would see through it. In like manner the spectator will see the left side of the gun on his left hand, and the right side of the gun on his right hand. If the spectator now changes his place, and takes ever such an oblique position, either laterally or vertically, he must still see the same thing; because nothing else is presented to his view. The gun of the middle soldier must always point to his eye, and the other guns to the right and left of him. They must therefore all three seem to move as he moves, and follow his eye in all its changes of place. The same observations are of course applicable to buildings and streets seen in perspective.

In common portraits the apparent motion of the head is generally rendered indistinct by the canvas being imperfectly stretched, as the slightest concavity or convexity entirely deforms the face when the obliquity is considerable. The deception is therefore best seen when the painting is executed on a very flat board, and in colours sufficiently vivid to represent every line in the face with tolerable distinctness at great obliquities. This distinctness of outline is indeed necessary to a satisfactory exhibition of this optical illusion. The most perfect exhibition, indeed, that I ever saw of it was in the case of a painting of a ship upon a sign-board executed in strongly gilt lines. It contained a view of the stern and side of a ship in the stocks, and, owing to the flatness of the board and the brightness of the lines, the gradual development of the figure, from the most violent foreshortening at great obliquities till it attained its perfect form, was an effect which surprised every person that saw it.

Fig. 29.

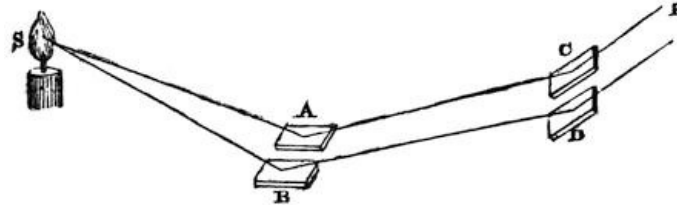

The only other optical illusion which our limits will permit us to explain, is the very remarkable experiment of what may be truly called *breathing light or darkness*. Let S be a candle whose light falls at an angle of $56^{\circ} 45'$ upon two glass plates A, B, placed close to each other, and let the reflected rays AC, BD, fall at the same angle upon two similar plates, C, D, but so placed that the plane of reflexion from the latter is at right angles to the plane of reflexion from the former. An eye placed at E, and looking at the same time into the two plates C and D, will see very faint images of the candle S, which by a slight adjustment of the plates, may be made to disappear almost wholly allowing the plate C to remain as it is, change the position of D, till its inclination to the ray BD is diminished about 3° , or made nearly $53^{\circ} 11'$. When this is done, the image that had disappeared on looking into D will be restored, so that the spectator at E, upon looking into the two mirrors C, D, will see no light in C, because the candle has nearly disappeared, while the candle is distinctly seen in D. If, while the spectator is looking into these two mirrors, either he or another person breathes upon them gently and quickly, the breath will revive the extinguished image in C, and will extinguish the visible image in D. The following is the cause of this singular result. The light AC, BD, is polarized by reflexion from the plates A, B, because it is incident at the polarizing angle of $56^{\circ} 45'$ for glass. When we breathe upon the plates C, D, we form upon their surface a thin film of water, whose polarizing angle is $53^{\circ} 11'$, so that if the polarized rays AC, BD, fell upon the plates C, D, at an angle of $53^{\circ} 11'$, the candle from which they proceeded would not be visible, or they would not suffer reflexion from the plates C, D. At all other angles the light would be reflected and the candles visible. Now the plate D is placed at an angle of $53^{\circ} 11'$ and C at an angle of $56^{\circ} 45'$, so that when a film of water is breathed upon them the light will be reflected from the latter, and none from the former; that is, the act of breathing upon the plates will restore the invisible and extinguish the visible image.

LETTER VI.

Natural phenomena marked with the marvellous—Spectre of the Brocken described—Analogous phenomena—Aërial spectres seen in Cumberland—Fata Morgana in the Straits of Messina—Objects below the horizon raised and magnified by refraction—Singular example seen at Hastings—Dover Castle seen through the hill on which it stands—Erect and inverted images of distant ships seen in the air—Similar phenomena seen in the Arctic regions—Enchanted coast—Mr. Scoresby recognizes his father's ship by its aërial image—Images of cows seen in the air—Inverted image of horses seen in South America—Lateral images produced by refraction—Aërial spectres by reflexion—Explanation of the preceding phenomena.

Among the wonders of the natural world which are every day presented to us, without either exciting our surprise or attracting our notice, some are occasionally displayed which possess all the characters of supernatural phenomena. In the names by which they are familiarly known, we recognize the terror which they inspired, and even now, when science has reduced them to the level of natural phenomena, and developed the causes from which they arise, they still retain their primitive importance, and are watched by the philosopher with as intense an interest as when they were deemed the immediate effects of Divine power. Among these phenomena we may enumerate the *Spectre of the Brocken*, the *Fata Morgana* of the Straits of Messina, the *Spectre Ships* which appear in the air, and the other extraordinary effects of the *Mirage*.¹⁴

The Brocken is the name of the loftiest of the Hartz mountains, a picturesque range which lies in the kingdom of Hanover. It is elevated 3,300 feet above the sea, and commands the view of a plain seventy leagues in extent, occupying nearly the two-hundredth part of the whole of Europe, and animated with a population of above five millions of inhabitants. From the earliest periods of authentic history, the Brocken has been the seat of the marvellous. On its summits are still seen huge blocks of granite called the Sorcerer's Chair and the Altar. A spring of pure water is known by the name of the Magic Fountain, and the Anemone of the Brocken is distinguished by the title of the Sorcerer's Flower. These names are supposed to have originated in the rites of the great idol Cortho, whom the Saxons worshipped in secret on the summit of the Brocken, when Christianity was extending her benignant sway over the subjacent plains.

As the locality of these idolatrous rites, the Brocken must have been much frequented, and we can scarcely doubt that the spectre which now so often haunts it at sunrise must have been observed from the earliest times; but it is nowhere mentioned that this phenomenon was in any way associated with the objects of their idolatrous worship. One of the best accounts of the spectre of the Brocken is that which is given by M. Haue, who saw it on the 23rd of May, 1797. After having been on the summit of the mountain no less than thirty times, he had at last the good fortune of witnessing the object of his curiosity. The sun rose about four o'clock in the morning through a serene atmosphere. In the south-west, towards Achtermannshohe, a brisk west wind carried before it the transparent vapours, which had not yet been condensed into thick heavy clouds. About a quarter past four he went towards the inn, and looked round to see whether the atmosphere would afford him a free prospect towards the south-west, when he observed at a very great distance, towards Achtermannshohe, a human figure of a monstrous size. His hat having been almost carried away by a violent gust of wind, he suddenly raised his hand to his head to protect his hat, and the colossal figure did the same. He immediately made another movement by bending his body,—an action which was repeated by the spectral figure. M. Haue was desirous of making further experiments, but the figure disappeared. He remained, however, in the same position, expecting its return, and in a few minutes it again made its appearance on the Achtermannshohe, when it mimicked his gestures as before. He then called the landlord of the inn, and having both taken the same position which he had before, they looked towards the Achtermannshohe, but saw nothing. In a very short space of time, however, two colossal figures were formed over the above eminence, and after bending their bodies and imitating the gestures of the two spectators, they disappeared. Retaining their position, and keeping their eyes still fixed upon the same spot, the two gigantic spectres again stood before them, *and were joined by a third*. Every movement that they made was imitated by the three figures, but the effect varied in its intensity, being sometimes weak and faint, and at other times strong and well defined.

Fig. 30.

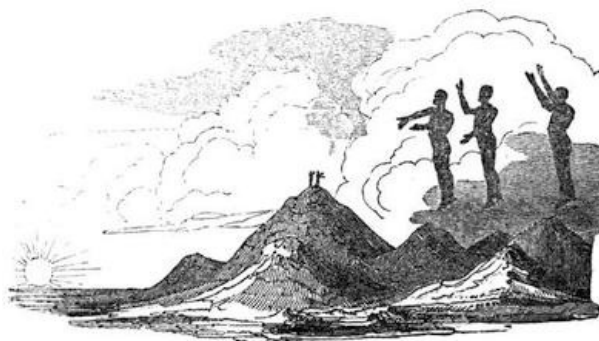

In the year 1798, M. Jordan saw the same phenomenon at sunrise, and under similar circumstances, but with less distinctness, and without any duplication of the figures.¹⁵

Phenomena perfectly analogous to the preceding, though seen under less imposing

circumstances, have been often witnessed. When the spectator sees his own shadow opposite to the sun upon a mass of thin fleecy vapour passing near him, it not only imitates all his movements, but its head is distinctly encircled with a halo of light. The aërial figure is often not larger than life, its size and its apparent distance depending, as we shall afterwards see, upon particular causes. I have often seen a similar shadow when bathing in a bright summer's day in an extensive pool of deep water. When the fine mud deposited at the bottom of the pool is disturbed by the feet of the bather, so as to be disseminated through the mass of water in the direction of his shadow, his shadow is no longer a shapeless mass formed upon the bottom, but is a regular figure formed upon the floating particles of mud, and having the head surrounded with a halo, not only luminous, but consisting of distinct radiations.

One of the most interesting accounts of aërial spectres with which we are acquainted has been given by Mr. James Clarke, in his Survey of the Lakes of Cumberland, and the accuracy of this account was confirmed by the attestations of two of the persons by whom the phenomena were first seen. On a summer's evening, in the year 1743, when Daniel Stricket, servant to John Wren, of Wilton Hall, was sitting at the door along with his master, they saw the figure of a man with a dog pursuing some horses along Souterfell-side, a place so extremely steep, that a horse could scarcely travel upon it at all. The figures appeared to run at an amazing pace, till they got out of sight at the lower end of the Fell. On the following morning, Stricket and his master ascended the steep side of the mountain, in the full expectation of finding the man dead, and of picking up some of the shoes of the horses, which they thought must have been cast while galloping at such a furious rate. Their expectations, however, were disappointed. No traces, either of man or horse, could be found, and they could not even discover upon the turf the single mark of a horse's hoof. These strange appearances seen at the same time by two different persons in perfect health, could not fail to make a deep impression on their minds. They at first concealed what they had seen, but they at length disclosed it, and were laughed at for their credulity.

In the following year, on the 23rd June, 1744, Daniel Stricket, who was then servant to Mr. Lancaster, of Blakehills, (a place near Wilton Hall, and both of which places are only about half a mile from Souterfell,) was walking, about seven o'clock in the evening, a little above the house, when he saw a troop of horsemen riding on Souterfell-side, in pretty close ranks, and at a brisk pace. Recollecting the ridicule that had been cast upon him the preceding year, he continued to observe the figures for some time in silence; but being at last convinced that there could be no deception in the matter, he went to the house, and informed his master that he had something curious to show him. They accordingly went out together; but before Stricket had pointed out the place, Mr. Lancaster's son had discovered the aërial figures. The family was then summoned to the spot, and the phenomena were seen alike by them all. The equestrian figures seemed to come from the lowest parts of Souterfell, and became visible at a place called Knott. They then advanced in regular troops along the side of the Fell, till they came opposite to Blakehills, when they went over the mountain, after describing a kind of curvilinear path. The pace at which the figures moved was a regular swift walk, and they continued to be seen for upwards of two hours, the approach of darkness alone preventing them from being visible. Many troops were seen in succession; and frequently the last but one in a troop quitted his position, galloped to the front, and took up the same pace with the rest. The changes in the figures were seen equally by all the spectators, and the view of them was not confined to the farm of Blakehills only, but they were seen by every person at every cottage within the distance of a mile, the number of persons who saw them amounting to about twenty-six. The attestation of these facts, signed by Lancaster and Stricket, bears the date of the 21st July, 1785.

These extraordinary sights were received not only with distrust, but with absolute incredulity. They were not even honoured with a place in the records of natural phenomena, and the philosophers of the day were neither in possession of analogous facts, nor were they acquainted with those principles of atmospherical refraction upon which they depend. The strange phenomena, indeed, of the *Fata Morgana*, or the *Castles of the Fairy Morgana*, had been long before observed, and had been described by Kircher in the 17th century, but they presented nothing so mysterious as the aërial troopers of Souterfell; and the general characters of the two phenomena were so unlike, that even a philosopher might have been excused for ascribing them to different causes.

This singular exhibition has been frequently seen in the straits of Messina, between Sicily and the coast of Italy, and whenever it takes place, the people, in a state of exultation, as if it were not only a pleasing but a lucky phenomenon, hurry down to the sea, exclaiming *Morgana, Morgana!* When the rays of the rising sun form an angle of 45° on the sea of Reggio, and when the surface of the water is perfectly unruffled, either by the wind or the current, a spectator placed upon an eminence in the city, and having his back to the sun and his face to the sea, observes upon the surface of the water superb palaces, with their balconies and windows, lofty towers, herds and flocks grazing in wooded valleys and fertile plains; armies of men on horseback and on foot, with multiplied fragments of buildings, such as columns, pilasters, and arches. These objects pass rapidly in succession along the surface of the sea during the brief period of their appearance. The various objects thus enumerated are pictures of palaces and buildings actually existing on shore, and the living objects are of course only seen when they happen to form a part of the general landscape.

If, at the time that these phenomena are visible, the atmosphere is charged with vapour or dense exhalations, the same objects which are depicted upon the sea will be seen also in the air, occupying a space which extends from the surface to the height of twenty-five feet. These

images, however, are less distinctly delineated than the former.

If the air is in such a state as to deposit dew, and is capable of forming the rainbow, the objects will be seen only on the surface of the sea; but they all appear fringed with red, yellow, and blue light, as if they were seen through a prism.

In our own country, and in our own times, facts still more extraordinary have been witnessed. From Hastings, on the coast of Sussex, the cliffs on the French coast are fifty miles distant, and they are actually hid by the convexity of the earth; that is, a straight line drawn from Hastings to the French coast would pass through the sea. On Wednesday, the 26th of July, 1798, about five o'clock in the afternoon, Mr. Latham, a Fellow of the Royal Society, then residing at Hastings, was surprised to see a crowd of people running to the sea-side. Upon inquiry into the cause of this, he learned that the coast of France could be seen by the naked eye, and he immediately went down to witness so singular a sight. He distinctly saw the cliffs extending for some leagues along the French coast, and they appeared as if they were only a few miles off. They gradually appeared more and more elevated, and seemed to approach nearer to the eye. The sailors with whom Mr. Latham walked along the waters edge were at first unwilling to believe in the reality of the appearance; but they soon became so thoroughly convinced of it, that they pointed out and named to him the different places which they had been accustomed to visit, and which they conceived to be as near as if they were sailing at a small distance into the harbour. These appearances continued for nearly an hour, the cliffs sometimes appearing brighter and nearer, and at other times fainter and more remote. Mr. Latham then went upon the eastern cliff or hill, which is of considerable height, when, as he remarks, a most beautiful scene presented itself to his view. He beheld at once Dungeness, Dover cliffs, and the French coast all along from Calais, Boulogne, &c., to St. Vallery, and, as some of the fishermen affirmed, as far west as Dieppe. With the help of a telescope, the French fishing-boats were plainly seen at anchor, and the different colours of the land upon the heights, together with the buildings, were perfectly discernible. Mr. Latham likewise states that the cape of land called Dungeness, which extends nearly two miles into the sea, and is about sixteen miles in a straight line from Hastings, appeared as if quite close to it, and the vessels and fishing-boats which were sailing between the two places appeared equally near, and were magnified to a high degree. These curious phenomena continued "in the highest splendour" till past eight o'clock, although a black cloud had for some time totally obscured the face of the sun.

A phenomenon no less marvellous was seen by Professor Vince, of Cambridge, and another gentleman, on the 6th of August, 1806, at Ramsgate. The summits *v w x y* of the four turrets of Dover Castle are usually seen over the hill *AB*, upon which it stands, lying between Ramsgate and Dover; but on the day above-mentioned, at seven o'clock in the evening, when the air was very still and a little hazy, not only were the tops *v w x y* of the four towers of Dover Castle seen over the adjacent hill *AB*, *but the whole of the Castle, m n r s, appeared as if it were situated on the side of the hill next Ramsgate*, and rising above the hill as much as usual. This phenomenon was so very singular and unexpected, that at first sight Dr. Vince thought it an illusion; but upon continuing his observations, he became satisfied that it was a real image of the Castle. Upon this he gave a telescope to a person present, who, upon attentive examination, saw also a very clear image of the Castle as the Doctor had described it. He continued to observe it for about twenty minutes, during which time the appearance remained precisely the same; but rain coming on, they were prevented from making any further observations. Between the observers and the land from which the hill rises there was about six miles of sea, and from thence to the top of the hill there was about the same distance. Their own height above the surface of the water was about seventy feet.

Fig. 31.

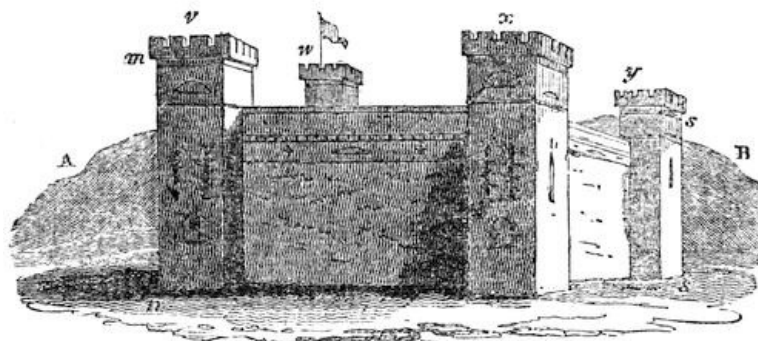

This illusion derived great force from the remarkable circumstance, that the hill itself did not appear through the image, as it might have been expected to do. The image of the castle was very strong and well defined, and though the rays from the hill behind it must undoubtedly have come to the eye, yet the strength of the image of the castle so far obscured the background, that it made no sensible impression on the observers. Their attention was of course principally directed to the image of the castle; but if the hill behind had been at all visible, Dr. Vince conceives that it could not have escaped their observation, as they continued to look at it for a considerable time with a good telescope.

Fig. 32.

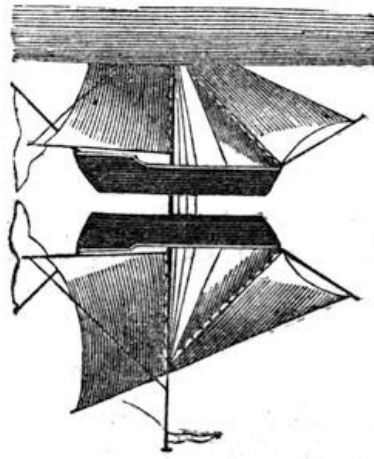

Hitherto our aërial visions have been seen only in their erect and natural positions, either projected against the ground or elevated in the air; but cases have occurred in which both erect and inverted images of objects have been seen in the air, sometimes singly, sometimes combined, sometimes when the real object was invisible, and sometimes when a part of it had begun to show itself to the spectator.

In the year 1793, Mr. Huddart, when residing at Allonby, in Cumberland, perceived the inverted image of a ship beneath the image, as shown in Fig. 32; but Dr. Vince, who afterwards observed this phenomenon under a greater variety of forms, found that the ship, which was here considered the real one, was only an erect image of the real ship, which was at that time beneath the horizon, and wholly invisible.

Fig. 33.

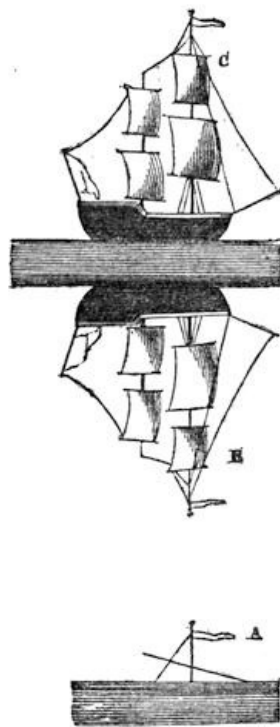

In August, 1798, Dr. Vince observed a great variety of these aërial images of vessels approaching the horizon. Sometimes there was seen only one inverted image above the real ship, and this was generally the case when the real ship was full in view. But when the real ship was just begin beginning to show its top-mast above the horizon, as at A, Fig. 33, two aërial images of it were seen, one at B inverted, and the other in its natural position at C. In this case the sea was distinctly visible between the erect and inverted images, but in other cases the hull of the one image was immediately in contact with the hull of the other.

Analogous phenomena were seen by Captain Scoresby when navigating with the ship Baffin the icy sea in the immediate neighbourhood of West Greenland. On the 28th of June, 1820, he observed about eighteen sail of ships at the distance of ten or fifteen miles. The sun had shone during the day without the interposition of a cloud, and its rays were peculiarly powerful. The intensity of its light occasioned a painful sensation in the eyes, while its heat softened the tar in the rigging of the ship, and melted the snow on the surrounding ice with such rapidity that pools of fresh water were formed on almost every place, and thousands of rills carried the excess into the sea. There was scarcely a breath of wind: the sea was as smooth as a mirror. The surrounding ice was crowded together, and exhibited every variety, from the smallest lumps to the most magnificent sheets. Bears traversed the fields and floes in unusual numbers, and many whales

sported in the recesses and openings among the drift ice. About six in the evening, a light breeze at N.W. having sprung up, a thin stratus or "fog bank," at first considerably illuminated by the sun, appeared in the same quarter, and gradually rose to the altitude of about a quarter of a degree. At this time most of the ships navigating at the distance of ten or fifteen miles began to change their form and magnitude, and when examined by a telescope from the mast-head, exhibited some extraordinary appearances, which differed at almost every point of the compass. One ship had a perfect image, as dark and distinct as the original, united to its mast-head in a reverse position. Two others presented two distinct inverted images in the air, one of them a perfect figure of the original, and the other wanting the hull. Two or three more were strangely distorted, their masts appearing of at least twice their proper height, the top-gallant mast forming one-half of the total elevation; and other vessels exhibited an appearance totally different from all the preceding, being as it were compressed, in place of elongated. Their masts seemed to be scarcely one-half of their proper altitude, in consequence of which one would have supposed that they were greatly heeled-to one side, or in the position called careening. Along with all the images of the ships a reflexion of the ice, sometimes in two strata, also appeared in the air, and these reflexions suggested the idea of cliffs composed of vertical columns of alabaster.

On the 15th, 16th, and 17th of the same month, Mr. Scoresby observed similar phenomena, sometimes extending continuously through half the circumference of the horizon, and at other times appearing only in detached spots in various quarters. The inverted images of distant vessels were often seen in the air, *while the ships themselves were far beyond the reach of vision*. Some ships were elevated to twice their proper height, while others were compressed almost to a line. Hummocks of ice were surprisingly enlarged, and every prominent object in a proper position was either magnified or distorted.

But of all the phenomena witnessed by Mr. Scoresby, that of the *Enchanted Coast*, as it may be called, must have been the most remarkable. This singular effect was seen on the 18th of July, when the sky was clear, and a tremulous and perfectly transparent vapour was particularly sensible and profuse: at nine o'clock in the morning, when the phenomenon was first seen, the thermometer stood at 42° Fahr.; but in the preceding evening it must have been greatly lower, as the sea was in many places covered with a considerable pellicle of new ice,—a circumstance, which, in the very warmest time of the year, must be considered as quite extraordinary, especially when it is known that 10° farther to the north no freezing of the sea at this season had ever before been observed. Having approached on this occasion so near the unexplored shore of Greenland that the land appeared distinct and bold, Mr. Scoresby was anxious to obtain a drawing of it; but on making the attempt he found that the outline was constantly changing, and he was induced to examine the coast with a telescope, and to sketch the various appearances which presented themselves. These are shown, without any regard to their proper order, in Fig. 34, which we shall describe in Mr. Scoresby's own words: "The general telescopic appearance of the coast was that of an extensive ancient city abounding with the ruins of castles, obelisks, churches, and monuments, with other large and conspicuous buildings. Some of the hills seemed to be surmounted by turrets, battlements, spires, and pinnacles; while others, subjected to one or two reflexions, exhibited large masses of rock, apparently suspended in the air, at a considerable elevation above the actual termination of the mountains to which they referred. The whole exhibition was a grand phantasmagoria. Scarcely was any particular portion sketched before it changed its appearance, and assumed the form of an object totally different. It was perhaps alternately a castle, a cathedral, or an obelisk; then expanding horizontally, and coalescing with the adjoining hills, united the intermediate valleys, though some miles in width, by a bridge of a single arch, of the most magnificent appearance and extent. Notwithstanding these repeated changes, the various figures represented in the drawing had all the distinctness of reality; and not only the different strata, but also the veins of the rocks, with the wreaths of snow occupying ravines and fissures, form sharp and distinct lines, and exhibited every appearance of the most perfect solidity."

Fig. 34.

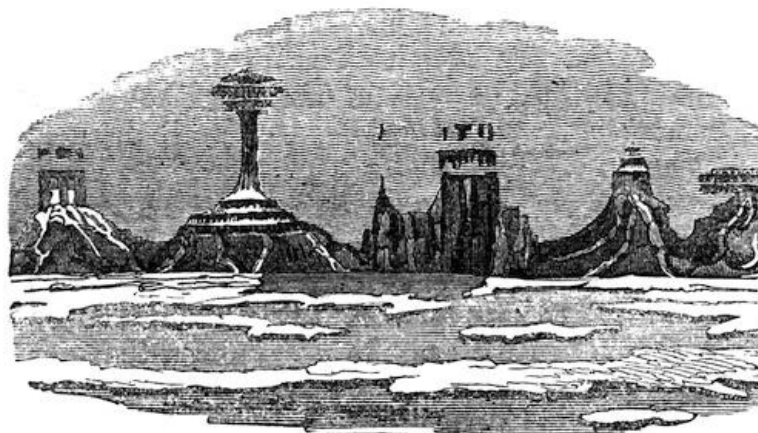

One of the most remarkable facts respecting aerial images presented itself to Mr. Scoresby in a later voyage which he performed to the coast of Greenland in 1822. Having seen an inverted image of a ship in the air, he directed to it his telescope; he was able to discover it to be his

father's ship, which was at the time below the horizon. "It was," says he, "so well defined, that I could distinguish by a telescope every sail, the general rig of the ship, and its particular character; insomuch, that I confidently pronounced it to be my father's ship, the *Fame*, which it afterwards proved to be; though, on comparing notes with my father, I found that our relative position, at the time, gave a distance from one another very nearly thirty miles, being about seventeen miles beyond the horizon, and some leagues beyond the limit of direct vision. I was so struck with the peculiarity of the circumstance, that I mentioned it to the officer of the watch, stating my full conviction that the *Fame* was then cruising in the neighbouring inlet."

Several curious effects of the mirage were observed by Baron Humboldt during his travels in South America. When he was residing at Cumana, he frequently saw the islands of Picuita and Boracha suspended in the air, and sometimes with an inverted image. On one occasion he observed small fishing-boats swimming in the air, during more than three or four minutes, above the well-defined horizon of the sea; and when they were viewed through a telescope, one of the boats had an inverted image accompanying it in its movements. This distinguished traveller observed similar phenomena in the barren steppes of the Caraccas, and on the borders of the Orinoco, where the river is surrounded by sandy plains. Little hills and chains of hills appeared suspended in the air, when seen from the steppes, at three or four leagues' distance. Palm-trees standing single in the Llanos appeared to be cut off at bottom, as if a stratum of air separated them from the ground; and, as in the African desert, plains destitute of vegetation appeared to be rivers or lakes. At the Mesa de Pavona M. Humboldt and M. Bonpland *saw cows suspended in the air* at the distance of 1000 toises, and having their feet elevated 3' 20" above the soil. In this case the images were erect, but the travellers learned from good authority that *inverted images of horses had been seen suspended in the air* near Calabozo.

In all these cases of aërial spectres, the images were directly above the real object; but a curious case was observed by Messrs. Jurine and Soret on the 17th September, 1818, where the image of the vessel was on one side of the real one. About 10 P.M. a barque at the distance of about 4000 toises from Bellerive, on the lake of Geneva, was seen approaching to Geneva by the *left* bank of the lake, and at the same time an image of the sails was observed above the water, which, instead of following the direction of the barque, separated from it, and appeared to approach Geneva by the right bank of the lake, the *image* moving from *east* to *west*, while the *barque* moved from *north* to *south*. When the image first separated from the barque they had both the same magnitude, but the image diminished as it receded from it, and was reduced to one-half when the phenomenon disappeared.

A very unusual example of aërial spectres occurred to Dr. A. P. Buchan while walking on the cliff about a mile to the east of Brighton, on the morning of the 28th of November, 1804. "While watching the rising of the sun," says he, "I turned my eyes directly towards the sea, just as the solar disk emerged from the surface of the water, and saw the face of the cliff on which I was standing represented precisely opposite to me at some distance on the ocean. Calling the attention of my companion to this appearance, we discerned our own figures standing on the summit of the apparent opposite cliff, as well as the representation of the windmill near at hand.

"The reflected images were most distinct precisely opposite to where we stood, and the false cliff seemed to fade away, and to draw near to the real one, in proportion as it receded towards the west. This phenomenon lasted about ten minutes, or till the sun had risen nearly his own diameter above the surface of the ocean. The whole then seemed to be elevated into the air, and successively disappeared, giving an impression very similar to that which is produced by the drawing up of a drop-scene in a theatre. The horizon was cloudy, or perhaps it might with more propriety be said that the surface of the sea was covered with a dense fog of many yards in height, and which gradually receded before the rays of the sun."

An illusion of a different kind, though not less interesting, is described by the Rev. Mr. Hughes in his Travels in Greece, as seen from the summit of Mount Ætna. "I must not forget to mention," says he, "one extraordinary phenomenon, which we observed, and for which I have searched in vain for a satisfactory solution. At the extremity of the vast shadow which Ætna projects across the island, appeared a perfect and distinct image of the mountain itself elevated above the horizon, and diminished as if viewed in a concave mirror. Where or what the reflector could be which exhibited this image, I cannot conceive; we could not be mistaken in its appearance, for all our party observed it, and we had been prepared for it beforehand by our Catanian friends. It remained visible about *ten* minutes, and disappeared as the shadow decreased. Mr. Jones observed the same phenomenon, as well as some other friends with whom I conversed upon the subject in England."

It is impossible to study the preceding phenomena without being impressed with the conviction, that nature is full of the marvellous, and that the progress of science and the diffusion of knowledge are alone capable of dispelling the fears which her wonders must necessarily excite even in enlightened minds. When a spectre haunts the couch of the sick, or follows the susceptible vision of the invalid, a consciousness of indisposition divests the apparition of much of its terror, while its invisibility to surrounding friends soon stamps it with the impress of a false perception. The spectres of the conjuror, too, however skilfully they may be raised, quickly lose their supernatural character; and even the most ignorant beholder regards the modern magician as but an ordinary man, who borrows from the sciences the best working implements of his art. But when, in the midst of solitude, and in situations where the mind is undisturbed by sublunary cares, we see our own image delineated in the air, and mimicking in gigantic perspective the tiny movements of humanity;—when we see troops in military array performing their evolutions on

the very face of an almost inaccessible precipice—when, in the eye of day, a mountain seems to become transparent, and exhibits on one side of it a castle which we know to exist only on the other; when distant objects, concealed by the roundness of the earth, and beyond the cognisance of the telescope, are actually transferred over the intervening convexity and presented in distinct and magnified outline to our accurate examination;—when such varied and striking phantasms are seen also by all around us, and therefore appear in the character of real phenomena of nature, our impressions of supernatural agency can only be removed by a distinct and satisfactory knowledge of the causes which gave them birth.

It is only within the last forty years that science has brought these atmospherical spectres within the circle of her dominion; and not only are all their phenomena susceptible of distinct explanation, but we can even reproduce them on a small scale with the simplest elements of our optical apparatus.

Fig. 35.

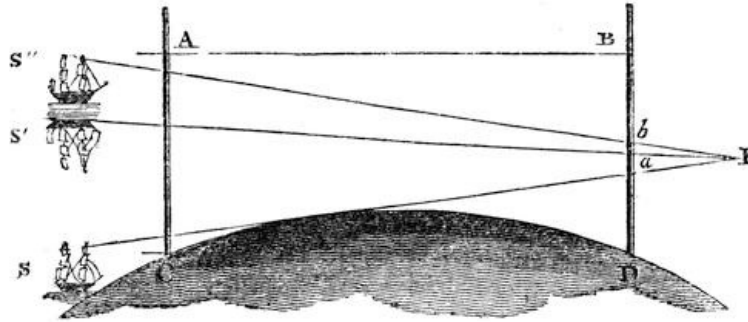

In order to convey a general idea of the causes of these phenomena, let ABCD, Fig. 35, be a glass trough filled with water, and let a small ship be placed at S. An eye situated about E, will see the top-mast of the ship S, directly through the plate of glass BD. Fix a convex lens *a* of short focus upon the plate of glass BD, and a little above a straight line SE joining the ship and the eye; and immediately above the convex lens a place *a* concave one *b*. The eye will now see, through the convex lens *a*, an *inverted* image of the ship at S', and through the concave lens *b*, an erect image of the ship at S'', representing in a general way the phenomena shown in Fig. 33. But it will be asked, where are the lenses in nature to produce these effects? This question is easily answered. If we take a tin tube with glass plates at each end, and fill it with water, and if we cool it on the outside with ice, it will act like a *concave* lens when the cooling effect has reached the axis; and, on the other hand, if we heat the same tube filled with water, on the outside, it will act as a *convex* glass. In the first case the density of the water diminishes towards the centre, and in the second it increases towards the centre. The very same effects are produced in the air, only a greater tract of air is necessary for showing the effect produced, by heating and cooling it unequally. If we now remove the lenses *a*, *b*, and hold a heated iron horizontally above the water in the trough ABC, the heat will gradually descend, expanding or rendering rarer the upper portions of the fluid. If, when the heat has reached within a little of the bottom, we look through the trough at the ship S in the direction ES', we shall see an inverted image at S', and an erect one at S''; and if we hide from the eye at E all the ship S, excepting the top-mast, we shall have an exact representation of the phenomenon in Fig. 33. The experiment will succeed better with oil in place of water; and the same result may be obtained without heat, by pouring clear syrup into the glass trough till it is nearly one-third full, and then filling it up with water. The water will gradually incorporate with the syrup, and produce, as Dr. Wollaston has shown, a regular gradation of density, diminishing from that of the pure syrup to that of the pure water. Similar effects may be obtained by using masses of transparent solids, such as glass, rock-salt, &c.

Now it is easy to conceive how the changes of density which we can thus produce artificially may be produced in nature. If, in serene weather, the surface of the sea is much colder than the air of the atmosphere, as it frequently is, and as it was to a very great degree during the phenomena described by Mr. Scoresby, the air next the sea will gradually become colder and colder, by giving out its heat to the water; and the air immediately above will give out its heat to the cooler air immediately below it, so that the air from the surface of the sea, to a considerable height upwards, will gradually diminish in density, and therefore must produce the very phenomena we have described.

Fig. 36.

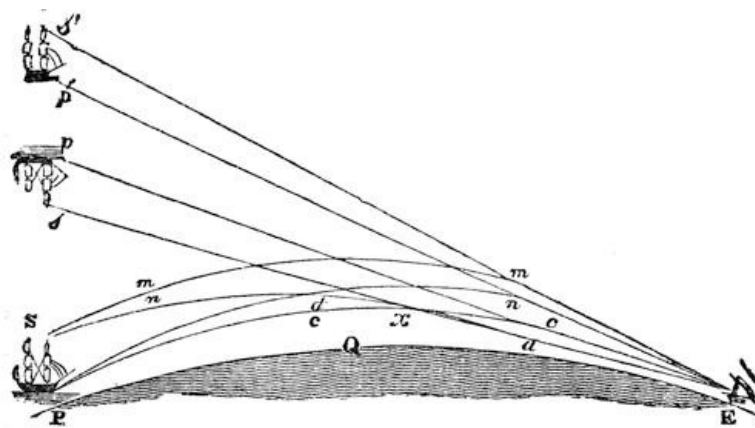

The phenomenon of Dover Castle seen on the Ramsgate side of the hill, was produced by the air being more dense near the ground and above the sea than at greater heights, and hence the rays proceeding from the castle reached the eye in curve lines, and the cause of its occupying its natural position on the hill, and not being seen in the air, was that the top of the hill itself, in consequence of being so near the castle, suffered the same change from the varying density of the air, and therefore the castle and the hill were equally elevated and retained their relative positions. The reason why the image of the castle and hill appeared erect was, that the rays from the top and bottom of the castle had not crossed before they reached Ramsgate; but as they met at Ramsgate, an eye at a greater distance from the castle, and in the path of the rays, would have seen the image inverted. This will be better understood from the preceding diagram, which represents the actual progress of the rays, from a ship SP, concealed from the observer at E by the convexity of the earth PQE. A ray proceeding from the keel of the ship P is refracted into the curve line P c x c E, and a ray proceeding from the top-mast S, is refracted in the direction S d x d E, the two rays crossing at x, and proceeding to the eye E with the ray from the keel P uppermost; hence the ship must appear inverted as at s p. Now if the eye E of the observer had been placed nearer the ship as at x, before the rays crossed, as was the case at Ramsgate, it would have seen an erect image of the ship raised a little above the real ship SP. Rays S m, S n, proceeding higher up in the air, are refracted in the directions S m m E, S n n E, but do not cross before they reach the eye, and therefore they afford the erect image of the ship shown at s' p'.

The aërial troopers seen at Souterfell were produced by the very same process as the spectre of Dover Castle, having been brought by unequal refraction from one side of the hill to the other. It is not our business to discover how a troop of soldiers came to be performing their evolutions on the other side of Souterfell; but if there was then no road along which they could be marching, it is highly probable that they were troops exercising among the hills in secret, previously to the breaking out of the rebellion in 1745.

The image of the Genevese barque which was seen sailing at a distance from the real one, arose from the same cause as the images of ships in the air; with this difference only, that in this case the strata of equal density were vertical or perpendicular to the water, whereas, in the former cases they were horizontal or parallel to the water. The state of the air which produced the lateral image may be produced by a headland or island, or even rocks, near the surface, and covered with water. These headlands, islands, or sunken rocks being powerfully heated by the sun in the daytime, will heat the air immediately above them, while the adjacent air over the sea will retain its former coolness and density. Hence there will necessarily arise a gradation of density varying in the same horizontal direction, or where the lines of equal density are vertical. If we suppose the very same state of the air to exist in a horizontal plane which exists in a vertical plane, in Fig. 36, then the same images would be seen in a horizontal line, viz., an inverted one at s p, and an erect one at s' p'. In the case of the Genevese barque, the rays had not crossed before they reached the eye, and therefore the image was an erect one. Had the real Genevese barque been concealed by some promontory or other cause from the observation of Messrs. Jurine and Soret, they might have attached a supernatural character to the spectral image, especially if they had seen it gradually decay, and finally disappear on the still and unbroken surface of the lake. No similar fact had been previously observed, and there were no circumstances in the case to have excited the suspicion that it was the spectre of a real vessel produced by unequal refraction.

The spectre of the Brocken and other phenomena of the same kind, have essentially a different origin from those which arise from unequal refraction. They are merely shadows of the observer projected on dense vapour or thin fleecy clouds, which have the power of reflecting much light. They are seen most frequently at sunrise, because it is at that time that the vapours and clouds necessary for their production are most likely to be generated; and they can be seen only when the sun is throwing his rays horizontally, because the shadow of the observer would otherwise be thrown either up in the air, or down upon the ground. If there are two persons looking at the phenomenon, as when M. Haue and the landlord saw it together, each observer will see his own image most distinctly, and the head will be more distinct than the rest of the figure, because the rays of the sun will be more copiously reflected at a perpendicular incidence: and as, from this cause, the light reflected from the vapour or cloud becomes fainter farther from the shadow, the appearance of a halo round the head of the observer is frequently visible. M. Haue mentions the extraordinary circumstance of the two spectres of him and the landlord being joined by a *third*

figure, but he unfortunately does not inform us which of the two figures was doubled, for it is impossible that a person could have joined their party unobserved. It is very probable that the new spectre forms a natural addition to the group, as we have represented it in Fig. 30; and, if this was the case, it could only have been produced by a duplication of one of the figures produced by unequal refraction.

The reflected spectre of Dr. Buchan standing upon the cliff at Brighton, arose from a cause to which we have not yet adverted. It was obviously no shadow, for it is certain, from the locality, that the rays of the sun fell upon the face of the cliff and upon his person at an angle of about 73° from the perpendicular, so as to illuminate them strongly. Now, there are two ways in which such an image may have been reflected, namely, either from strata of air of variable density, or from a vertical stratum of vapour, consisting of exceedingly minute globules of water. Whenever light suffers refraction, either in passing at once from one medium into another, or from one part of the same medium into another of different density, a portion of it suffers reflexion. If an object, therefore, were strongly illuminated, a sufficiently distinct image, or rather shadow of it, might be seen by reflexion from strata of air of different density. As the temperature at which moisture is deposited in the atmosphere varies with the density of the air, then at the same temperature moisture might be depositing in a stratum of one density, while no deposition is taking place in the adjacent stratum of a different density. Hence there would exist, as it were in the air, a vertical wall or stratum of minute globules of water, from the surface of which a sufficiently distinct image of a highly illuminated object might be reflected. That this is possible may be proved by breathing upon glass. If the particles deposited upon the glass are large, then no distinct reflection will take place; but if the particles be very small, we shall see a distinct image formed by the surface of the aqueous film.

The phenomena of the Fata Morgana have been too imperfectly described to enable us to offer a satisfactory explanation of them. The aërial images are obviously those formed by unequal refraction. The pictures seen on the sea may be either the aërial images reflected from its surface, or from a stratum of dense vapour, or they may be the direct reflexions from the objects themselves. The coloured images, as described by Minasi, have never been seen in any analogous phenomena, and require to be better described before they can be submitted to scientific examination.

The representation of ships in the air by unequal refraction has no doubt given rise in early times to those superstitions which have prevailed in different countries respecting "phantom ships," as Mr. Washington Irving calls them, which always sail in the eye of the wind, and plough their way through the smooth sea, where there is not a breath of wind upon its surface. In his beautiful story of the storm ship, which makes its way up the Hudson against wind and tide, this elegant writer has finely embodied one of the most interesting superstitions of the early American colonists. The Flying Dutchman had, in all probability, a similar origin; and the wizard beacon-keeper of the Isle of France, who saw in the air the vessels bound to the island long before they appeared in the offing, must have derived his power from a diligent observation of the phenomena of nature.

LETTER VII.

Illusions depending on the ear—Practised by the ancients—Speaking and singing heads of the ancients—Exhibition of the Invisible Girl described and explained—Illusions arising from the difficulty of determining the direction of sounds—Singular example of this illusion—Nature of ventriloquism—Exhibitions of some of the most celebrated ventriloquists—M. St. Gille—Louis Brabant—M. Alexandre—Capt. Lyon's account of Esquimaux ventriloquists.

Next to the eye, the ear is the most fertile source of our illusions, and the ancient magicians seem to have been very successful in turning to their purposes the doctrines of sound. In the Labyrinth of Egypt, which contained twelve palaces and 1500 subterraneous apartments, the gods were made to speak in a voice of thunder; and Pliny, in whose time this singular structure existed, informs us, that some of the palaces were so constructed that their doors could not be opened without permitting the peals of thunder to be heard in the interior. When Darius Hystaspes ascended the throne, and allowed his subjects to prostrate themselves before him as a god, the divinity of his character was impressed upon his worshippers by the bursts of thunder and flashes of lightning which accompanied their devotion. History has of course not informed us how these effects were produced; but it is probable that, in the subterraneous and vaulted apartments of the Egyptian labyrinth, the reverberated sounds arising from the mere opening and shutting of the doors themselves afforded a sufficient imitation of ordinary thunder. In the palace of the Persian king, however, a more artificial imitation is likely to have been employed, and it is not improbable that the method used in our modern theatres was known to the ancients. A thin sheet of iron, three or four feet long, such as that used for German stoves, is held by one corner between the finger and the thumb, and allowed to hang freely by its own weight. The hand is then moved or shaken horizontally, so as to agitate the corner in a direction at right angles to the surface of the sheet. By this simple process a great variety of sounds may be produced, varying from the deep growl of distant thunder to those loud and explosive bursts which rattle in quick succession from clouds immediately over our heads. The operator soon acquires great power over this instrument, so as to be able to produce from it any intensity and character of sound that may be required. The same effect may be produced by sheets of tin-plate, and by thin plates of mica; but, on account of their small size, the sound is shorter and more acute. In modern exhibitions an admirable imitation of lightning is produced by throwing the powder of rosin, or the dust of lycopodium, through a flame; and the rattling showers of rain which accompany these meteors are well imitated by a well-regulated shower of peas.

The principal pieces of acoustic mechanism used by the ancients were *speaking* or *singing heads*, which were constructed for the purpose of representing the gods, or of uttering oracular responses. Among these, the speaking head of Orpheus, which uttered its responses at Lesbos, is one of the most famous. It was celebrated not only throughout Greece, but even in Persia; and it had the credit of predicting, in the equivocal language of the heathen oracles, the bloody death which terminated the expedition of Cyrus the Great into Scythia. Odin, the mighty magician of the North, who imported into Scandinavia the magical arts of the East, possessed a speaking head, said to be that of the sage Minos, which he had encased in gold, and which uttered responses that had all the authority of a divine revelation. The celebrated mechanic Gerbert, who filled the papal chair A.D. 1000, under the name of Sylvester II., constructed a speaking head of brass. Albertus Magnus is said to have executed a head in the thirteenth century, which not only moved but spoke. It was made of earthenware, and Thomas Aquinas is said to have been so terrified when he saw it, that he broke it in pieces; upon which the mechanist exclaimed, "There goes the labour of thirty years!"

It has been supposed by some authors, that in the ancient speaking-machines the deception is effected by means of ventriloquism, the voice issuing from the juggler himself; but it is more probable that the sound was conveyed by pipes from a person in another apartment to the mouth of the figure. Lucian, indeed, expressly informs us, that the impostor Alexander made his figure of Æsculapius speak, by transmitting his voice through the gullet of a crane to the mouth of the statue; and that this method was general appears from a passage in Theodoretus, who assures us, that in the fourth century, when Bishop Theophilus broke to pieces the statues at Alexandria, he found some which were hollow, and which were so placed against a wall, that the priest could conceal himself behind them; and address the ignorant spectators through their mouths.

Even in modern times, speaking-machines have been constructed on this principle. The figure is frequently a mere head placed upon a hollow pedestal, which, in order to promote the deception, contains a pair of bellows, a sounding-board, a cylinder and pipes supposed to represent the organs of speech. In other cases these are dispensed with, and a simple wooden head utters its sounds through a speaking trumpet. At the court of Charles II., this deception was exhibited with great effect by one Thomas Irson, an Englishman; and when the astonishment had become very general, a popish priest was discovered by one of the pages in an adjoining apartment. The questions had been proposed to the wooden figure by whispering into its ear, and this learned personage had answered them all with great ability, by speaking through a pipe in the same language in which the questions were proposed. Professor Beckmann informs us that children and women were generally concealed either in the juggler's box or in the adjacent apartment, and that the juggler gave them every assistance by means of signs previously agreed upon. When one of these exhibitions was shown at Göttingen, the Professor was allowed, on the promise of secrecy, to witness the process of deception. He saw the assistant in another room, standing before the pipe with a card in his hand, upon which the signs agreed upon had been marked, and he had been introduced so privately into the house that even the landlady was ignorant of his being there.

An exhibition of the very same kind has been brought forward in our own day, under the name of the *Invisible Girl*; and as the mechanism employed was extremely ingenious, and is well fitted to convey an idea of this class of deceptions, we shall give a detailed description of it.

Fig. 37.

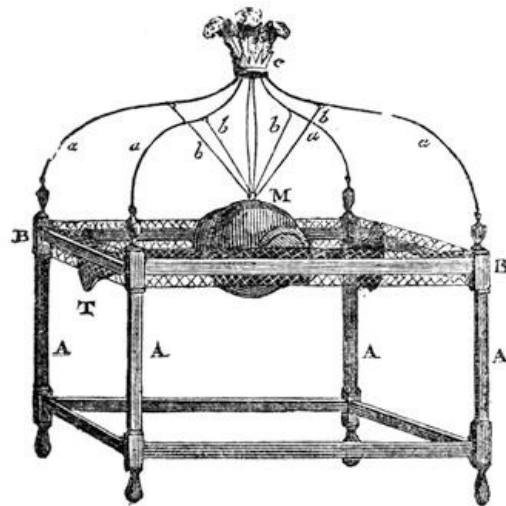

The machinery, as constructed by M. Charles, is shown in fig. 37 in perspective, and a plan of it in Fig. 38. The four upright posts A, A, A, A, are united at top by a cross rail B, B, and by two similar rails at bottom. Four bent wires a, a, a, a, proceeded from the top of these posts, and terminated at c. A hollow copper ball M, about a foot in diameter, was suspended from these wires by four slender ribands b, b, b, b, and into the copper ball were fixed the extremities of four trumpets T, T, T, T, with their mouths outwards.

Fig. 38.

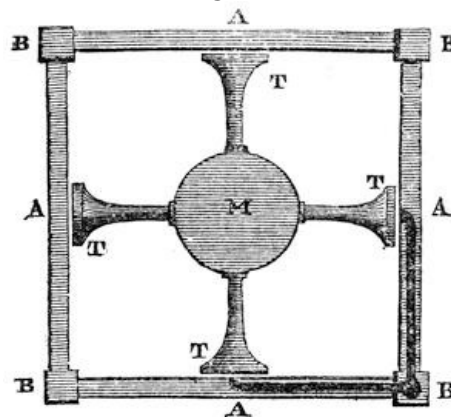

The apparatus now described was all that was visible to the spectator; and though fixed in one spot, yet it had the appearance of a piece of separate machinery, which might have occupied any other part of the room. When one of the spectators was requested by the exhibitor to propose some question, he did it by speaking into one of the trumpets at T. An appropriate answer was then returned from all the trumpets, and the sound issued with sufficient intensity to be heard by an ear applied to any of them, and yet it was so weak that it appeared to come from a person of very diminutive size. Hence the sound was supposed to come from an invisible girl, though the real speaker was a full-grown woman. The invisible lady conversed in different languages, sang beautifully, and made the most lively and appropriate remarks on the persons in the room.

This exhibition was obviously far more wonderful than the speaking heads which we have described, as the latter invariably communicated with a wall, or with a pedestal through which pipes could be carried into the next apartment. But the ball M and its trumpets communicated with nothing through which sound could be conveyed. The spectator satisfied himself by examination that the ribands b, b, were real ribands, which concealed nothing, and which could convey no sound; and as he never conceived that the ordinary piece of frame-work AB could be of any other use than its apparent one of supporting the sphere M, and defending it from the spectators, he was left in utter amazement respecting the origin of the sound, and his surprise was increased by the difference between the sounds which were uttered and those of ordinary speech.

Though the spectators were thus deceived by their own reasoning, yet the process of deception was a very simple one. In two of the horizontal railings A, A, Fig. 38, opposite the trumpet mouths T, there was an aperture communicating with a pipe or tube which went to the vertical post B, and descending it, as shown at TAA, Fig. 39, went beneath the floor ff, in the direction p p, and entered the apartment N, where the invisible lady sat. On the side of the partition about h, there was a small hole through which the lady saw what was going on in the exhibition-room, and communications were no doubt made to her by signals from the person who attended the machine. When one of the spectators asked a question by speaking into one of the trumpets T,

the sound was reflected from the mouth of the trumpet back to the aperture at A, in the horizontal rail, Fig. 38, and was distinctly conveyed along the closed tube into the apartment N. In like manner the answer issued from the aperture A, and being reflected back to the ear of the spectator by the trumpet, he heard the sounds with that change of character which they receive when transmitted through a tube and then reflected to the ear.

Fig. 39.

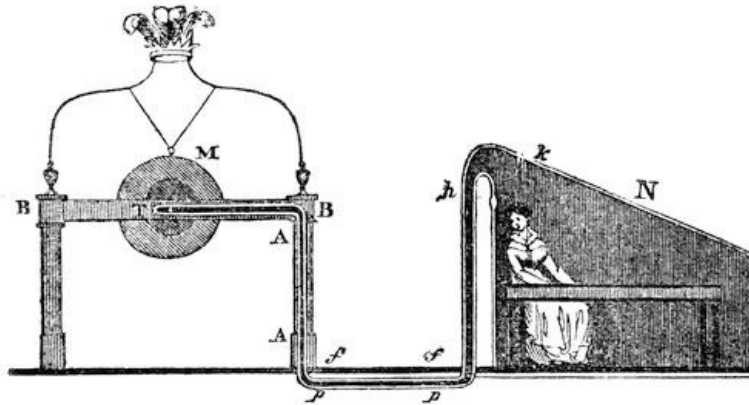

The surprise of the auditors was greatly increased by the circumstance, that an answer was returned to questions put in a whisper, and also by the conviction that nobody but a person in the middle of the audience could observe the circumstances to which the invisible figure frequently adverted.

Although the performances of speaking heads were generally effected by the methods now described, yet there is reason to think that the ventriloquist sometimes presided at the exhibition, and deceived the audience by his extraordinary powers of illusion. There is no species of deception more irresistible in its effects than that which arises from the uncertainty with which we judge of the direction and distance of sounds. Every person must have noticed how a sound in their own ears is often mistaken for some loud noise moderated by the distance from which it is supposed to come; and the sportsman must have frequently been surprised at the existence of musical sounds humming remotely in the extended heath, when it was only the wind sounding in the barrel of his gun. The great proportion of apparitions that haunt old castles and apartments associated with death, exist only in the sounds which accompany them. The imagination even of the boldest inmate of a place hallowed by superstition, will transfer some trifling sound near his own person to a direction and to a distance very different from the truth, and the sound which otherwise might have no peculiar complexion will derive another character from its new locality. Spurning the idea of a supernatural origin, he determines to unmask the spectre, and grapple with it in its den. All the inmates of the house are found to be asleep—even the quadrupeds are in their lair—there is not a breath of wind to ruffle the lake that reflects through the casement the reclining crescent of the night; and the massive walls in which he is enclosed forbid the idea that he has been disturbed by the warping of panelling or the bending of partitions. His search is vain; and he remains master of his own secret, till he has another opportunity of investigation. The same sound again disturbs him, and, modified probably by his own position at the time, it may perhaps appear to come in a direction slightly different from the last. His searches are resumed, and he is again disappointed. If this incident should recur night after night with the same result—if the sound should appear to depend upon his own motions, or be any how associated with himself, with his present feelings, or with his past history, his personal courage will give way; a superstitious dread, at which he himself perhaps laughs, will seize his mind; and he will rather believe that the sounds have a supernatural origin, than that they could continue to issue from a spot where he knows there is no natural cause for their production.

I have had occasion to have personal knowledge of a case much stronger than that which has now been put. A gentleman, devoid of all superstitious feelings, and living in a house free from any gloomy associations, heard night after night in his bed-room a singular noise, unlike any ordinary sound to which he was accustomed. He had slept in the same room for years without hearing it, and he attributed it at first to some change of circumstances in the roof or in the walls of the room, but after the strictest examination no cause could be found for it. It occurred only once in the night; it was heard almost every night, with few interruptions. It was over in an instant, and it never took place till after the gentleman had gone to bed. It was always distinctly heard by his companion, to whose time of going to bed it had no relation. It depended on the gentleman alone, and it followed him into another apartment with another bed, on the opposite side of the house. Accustomed to such investigations, he made the most diligent but fruitless search into its cause. The consideration that the sound had a special reference to him alone, operated upon his imagination, and he did not scruple to acknowledge that the recurrence of the mysterious sound produced a superstitious feeling at the moment. Many months afterwards it was found that the sound arose from the partial opening of the door of a wardrobe which was within a few feet of the gentleman's head, and which had been taken into the other apartment. This wardrobe was almost always opened before he retired to bed, and the door being a little too tight, it gradually forced itself open with a sort of dull sound, resembling the note of a drum. As the door had only started half an inch out of its place, its change of position never attracted attention. The sound, indeed, seemed to come in a different direction, and from a greater

distance.

When sounds so mysterious in their origin are heard by persons predisposed to a belief in the marvellous, their influence over the mind must be very powerful. An inquiry into their origin, if it is made at all, will be made more in the hope of confirming than of removing the original impression, and the unfortunate victim of his own fears will also be the willing dupe of his own judgment.

This uncertainty with respect to the direction of sound is the foundation of the art of ventriloquism. If we place ten men in a row at such a distance from us that they are included in the angle within which we cannot judge of the direction of sound, and if in a calm day each of them speaks in succession, we shall not be able with closed eyes to determine from which of the ten men any of the sounds proceed, and we shall be incapable of perceiving that there is any difference in the direction of the sounds emitted by the two outermost. If a man and a child are placed within the same angle, and if the man speaks with the accent of a child without any corresponding motion in his mouth or face, we shall necessarily believe that the voice comes from the child; nay, if the child is so distant from the man that the voice actually appears to us to come from the man, we shall still continue in the belief that the child is the speaker; and this conviction would acquire additional strength if the child favoured the deception, by accommodating its features and gestures to the words spoken by the man. So powerful, indeed, is the influence of this deception, that if a jack-ass, placed near the man, were to open its mouth, and shake its head responsive to the words uttered by his neighbour, we should rather believe that the ass spoke than that the sounds proceeded from a person whose mouth was shut, and the muscles of whose face were in perfect repose. If our imagination were even directed to a marble statue or a lump of inanimate matter, as the source from which we were to expect the sounds to issue, we would still be deceived, and would refer the sounds even to these lifeless objects. The illusion would be greatly promoted, if the voice were totally different in its tone and character from that of the man from whom it really comes; and if he occasionally speaks in his own full and measured voice, the belief will be irresistible that the assumed voice proceeds from the quadruped or from the inanimate object.

When the sounds which are required to proceed from any given object are such as they are actually calculated to yield, the process of deception is extremely easy; and it may be successfully executed, even if the angle between the real and the supposed direction of the sound is much greater than the angle of uncertainty. Mr. Dugald Stewart has stated some cases in which deceptions of this kind were very perfect. He mentions his having seen a person who, by counterfeiting the gesticulations of a performer on the violin, while he imitated the music by his voice, riveted the eyes of his audience on the instrument, though every sound they heard proceeded from his own mouth. The late Savile Carey, who imitated the whistling of the wind through a narrow chink, told Mr. Stewart that he had frequently practised this deception in the corner of a coffee-house, and that he seldom failed to see some of the company rise to examine the tightness of the windows, while others, more intent on their newspapers, contented themselves with putting on their hats and buttoning their coats. Mr. Stewart likewise mentions an exhibition formerly common in some of the continental theatres, where a performer on the stage displayed the dumb-show of singing with his lips and eyes and gestures, while another person unseen supplied the music with his voice. The deception in this case he found to be at first so complete as to impose upon the nicest ear and the quickest eye; but in the progress of the entertainment, he became distinctly sensible of the imposition, and sometimes wondered that it should have misled him for a moment. In this case there can be no doubt that the deception was at first the work of the imagination, and was not sustained by the acoustic principle. The real and the mock singer were too distant, and when the influence of the imagination subsided, the true direction of the sound was discovered. This detection of the imposture, however, may have arisen from another cause. If the mock singer happened to change the position of his head, while the real singer made no corresponding change in his voice, the attentive spectator would at once notice this incongruity, and discover the imposition.

In many of the feats of ventriloquism the performer contrives, under some pretence or other, to conceal his face, but ventriloquists of great distinction, such as M. Alexandre, practise their art without any such concealment.

Ventriloquism loses its distinctive character if its imitations are not performed by a voice from the belly. The voice, indeed, does not actually come from that region; but when the ventriloquist utters sounds from the larynx without moving the muscles of his face, he gives them strength by a powerful action of the abdominal muscles. Hence he speaks by means of his belly, although the throat is the real source from whence the sounds proceed. Mr. Dugald Stewart has doubted the fact, that ventriloquists possess the power of fetching a voice from within: he cannot conceive what aid could be derived from such an extraordinary power; and he considers that the imagination, when seconded by such powers of imitation as some mimics possess, is quite sufficient to account for all the phenomena of ventriloquism which he has heard. This opinion, however, is strongly opposed by the remark made to Mr. Stewart himself by a ventriloquist, "that his art would be perfect, if it were possible only to speak distinctly without any movement of the lips at all." But, independent of this admission, it is a matter of absolute certainty, that this internal power is exercised by the true ventriloquist. In the account which the Abbé Chapelle has given of the performances of M. St. Gille and Louis Brabant, he distinctly states that M. St. Gille appeared to be absolutely mute while he was exercising his art, and that no change in his countenance could be discovered.¹⁶ He affirms, also, that the countenance of Louis Brabant

exhibited no change, and that his lips were close and inactive. M. Richerand, who attentively watched the performances of M. Fitz-James, assures us that during his exhibition there was a distention in the epigastric region, and that he could not long continue the exertion without fatigue.

The influence over the human mind which the ventriloquist derives from the skilful practice of his art is greater than that which is exercised by any other species of conjuror. The ordinary magician requires his theatre, his accomplices, and the instruments of his art, and he enjoys but a local sovereignty within the precincts of his own magic circle. The ventriloquist, on the contrary, has the supernatural always at his command. In the open fields as well as in the crowded city, in the private apartment as well as in the public hall, he can summon up innumerable spirits; and though the persons of his fictitious dialogue are not visible to the eye, yet they are unequivocally present to the imagination of his auditors, as if they had been shadowed forth in the silence of a spectral form. In order to convey some idea of the influence of this illusion, I shall mention a few well-authenticated cases of successful ventriloquism.

M. St. Gille, a grocer of St. Germain-en-Laye, whose performances have been recorded by the Abbé de la Chapelle, had occasion to shelter himself from a storm in a neighbouring convent, where the monks were in deep mourning for a much-esteemed member of their community who had been recently buried. While lamenting over the tomb of their deceased brother the slight honours which had been paid to his memory, a voice was suddenly heard to issue from the roof of the choir bewailing the condition of the deceased in purgatory, and reproving the brotherhood for their want of zeal. The tidings of this supernatural event brought the whole brotherhood to the church. The voice from above repeated its lamentations and reproaches, and the whole convent fell upon their faces, and vowed to make a reparation of their error. They accordingly chanted in full choir a *De Profundis*, during the intervals of which the spirit of the departed monk expressed his satisfaction at their pious exercises. The prior afterwards inveighed against modern scepticism on the subject of apparitions, and M. St. Gille had great difficulty in convincing the fraternity that the whole was a deception.

On another occasion, a commission of the Royal Academy of Sciences at Paris, attended by several persons of the highest rank, met at St. Germain-en-Laye to witness the performances of M. St. Gille. The real object of their meeting was purposely withheld from a lady of the party, who was informed that an aerial spirit had lately established itself in the neighbourhood, and that the object of the assembly was to investigate the matter. When the party had sat down to dinner in the open air, the spirit addressed the lady in a voice which seemed to come from above their heads, from the surface of the ground at a great distance, or from a considerable depth under her feet. Having been thus addressed at intervals during two hours, the lady was firmly convinced of the existence of the spirit, and could with difficulty be undeceived.

Another ventriloquist, Louis Brabant, who had been valet-de-chambre to Francis I., turned his powers to a more profitable account. Having fallen in love with a rich and beautiful heiress, he was rejected by her parents as an unsuitable match for their daughter. On the death of her father, Louis paid a visit to the widow, and he had no sooner entered the house than she heard the voice of her deceased husband addressing her from above, "Give my daughter in marriage to Louis Brabant, who is a man of large fortune and excellent character. I endure the inexpressible torments of purgatory for having refused her to him. Obey this admonition, and give everlasting repose to the soul of your poor husband." This awful command could not be resisted, and the widow announced her compliance with it.

As our conjuror, however, required money for the completion of his marriage, he resolved to work upon the fears of one Cornu, an old banker at Lyons, who had amassed immense wealth by usury and extortion. Having obtained an interview with the miser, he introduced the subjects of demons and spectres, and the torments of purgatory; and, during an interval of silence, the voice of the miser's deceased father was heard complaining of his dreadful situation in purgatory, and calling upon his son to rescue him from his sufferings by enabling Louis Brabant to redeem the Christians that were enslaved by the Turks. The awe-struck miser was also threatened with eternal damnation if he did not thus expiate his own sins; but such was the grasp that the banker took of his gold, that the ventriloquist was obliged to pay him another visit. On this occasion, not only his father but all his deceased relatives appealed to him in behalf of his own soul and theirs; and such was the loudness of their complaints, that the spirit of the banker was subdued, and he gave the ventriloquist ten thousand crowns to liberate the Christian captives. When the miser was afterwards undeceived, he is said to have been so mortified that he died of vexation.

The ventriloquists of the nineteenth century made great additions to their art, and the performances of M. Fitz-James and M. Alexandre, which must have been seen by many of our countrymen, were far superior to those of their predecessors. Besides the art of speaking by the muscles of the throat and the abdomen, without moving those of the face, these artists had not only studied with great diligence and success the modifications which sounds of all kinds undergo from distance, obstructions, and other causes, but had acquired the art of imitating them in the highest perfection. The ventriloquist was therefore able to carry on a dialogue in which the *dramatis voces*, as they may be called, were numerous; and when on the outside of an apartment, he could personate a mob with its infinite variety of noise and vociferation. Their influence over an audience was still further extended by a singular power over the muscles of the body. M. Fitz-James actually succeeded in making the opposite or corresponding muscles act differently from each other; and while one side of his face was merry and laughing, the other was full of sorrow and in tears. At one moment he was tall, thin, and melancholic, and after pausing behind a

screen, he came out "bloated with obesity and staggering with fulness." M. Alexandre possessed the same power over his face and figure; and so striking was the contrast of two of these forms, that an excellent sculptor, Mr. Joseph, has perpetuated them in marble.

This new acquirement of the ventriloquist enabled him, in his own single person and with his own single voice, to represent upon the stage a dramatic composition which would have required the assistance of several actors. Although only one character in the piece could be seen at the same time, yet they all appeared during its performance, and the change of face and figure on the part of the ventriloquist was so perfect, that his personal identity could not be recognized in the *dramatis personæ*. This deception was rendered still more complete by a particular construction of the dresses, which enabled the performer to reappear in a new character after an interval so short that the audience necessarily believed that it was another person.

It is a curious circumstance that Captain Lyon found among the Esquimaux of Igloolik ventriloquists of no mean skill. There is much rivalry among the professors of the art, who do not expose each other's secrets, and their exhibitions derive great importance from the rarity of their occurrence. The following account of one of them is so interesting that we shall give the whole of it in Captain Lyon's words:—

"Amongst our Igloolik acquaintances were two females and a few male wizards, of whom the principal was Toolemak. This personage was cunning and intelligent; and, whether professionally, or from his skill in the chase, but perhaps from both reasons, was considered by all the tribe as a man of importance. As I invariably paid great deference to his opinion on all subjects connected with his calling, he freely communicated to me his superior knowledge, and did not scruple to allow of my being present at his interviews with Tornga, or his patron spirit. In consequence of this, I took an early opportunity of requesting my friend to exhibit his skill in my cabin. His old wife was with him, and by much flattery and an accidental display of a glittering knife and some beads, she assisted me in obtaining my request. All light excluded, our sorcerer began chanting to his wife with great vehemence, and she in return answered by singing the Amna-aya, which was not discontinued during the whole ceremony. As far as I could hear, he afterwards began turning himself rapidly round, and in a loud, powerful voice vociferated for Tornga with great impatience, at the same time blowing and snorting like a walrus. His noise, impatience, and agitation increased every moment, and he at length seated himself on the deck, varying his tones, and making a rustling with his clothes. Suddenly the voice seemed smothered, and was so managed as to sound as if retreating beneath the deck, each moment becoming more distant, and ultimately giving the idea of being many feet below the cabin, when it ceased entirely. His wife now, in answer to my queries, informed me very seriously, that he had dived, and that he would send up Tornga. Accordingly, in about half a minute, a distant blowing was heard very slowly approaching, and a voice, which differed from that at first heard, was at times mingled with the blowing, until at length both sounds became distinct, and the old woman informed me that Tornga was come to answer my questions. I accordingly asked several questions of the sagacious spirit, to each of which inquiries I received an answer by two loud claps on the deck, which I was given to understand were favourable.

"A very hollow, yet powerful voice, certainly much different from the tones of Toolemak, now chanted for some time, and a strange jumble of hisses, groans, shouts, and gabblings like a turkey, succeeded in rapid order. The old woman sang with increased energy; and as I took it for granted that this was all intended to astonish the Kabloona, I cried repeatedly that I was very much afraid. This, as I expected, added fuel to the fire, until the poor immortal, exhausted by its own might, asked leave to retire.

"The voice gradually sank from our hearing as at first, and a very indistinct hissing succeeded; in its advance it sounded like the tone produced by the wind on the brass chord of an Æolian harp. This was soon changed to a rapid hiss like that of a rocket, and Toolemak with a yell announced his return. I had held my breath at the first distant hissing, and twice exhausted myself, yet our conjuror did not once respire, and even his returning and powerful yell was uttered without a previous stop or inspiration of air.

"Light being admitted, our wizard, as might be expected, was in a profuse perspiration, and certainly much exhausted by his exertions, which had continued for at least half an hour. We now observed a couple of bunches, each consisting of two stripes of white deer-skin, and a long piece of sinew, attached to the back of his coat. These we had not seen before, and were informed that they had been sewn on by Tornga while he was below."¹⁷

Captain Lyon had the good fortune to witness another of Toolemak's exhibitions, and he was much struck with the wonderful steadiness of the wizard throughout the whole performance, which lasted an hour and a half. He did not once appear to move, for he was so close to the skin behind which Captain Lyon sat, that if he had done so he must have perceived it. Captain Lyon did not hear the least rustling of his clothes, or even distinguish his breathing, although his outcries were made with great exertion.¹⁸

LETTER VIII.

Musical and harmonic sounds explained—Power of breaking glasses with the voice—Musical sounds from the vibration of a column of air—and of solid bodies—Kaleidophone—Singular acoustic figures produced on sand laid on vibrating plates of glass—and on stretched membranes—Vibration of flat rulers and cylinders of glass—Production of silence from two sounds—Production of darkness from two lights—Explanation of these singular effects—Acoustic automaton—Droz's bleating sheep—Maillardet's singing-bird—Vaucanson's flute-player—His pipe and tabor-player—Baron Kempelen's talking-engine—Kratzenstein's speaking-machine—Mr. Willis's researches.

Among the discoveries of modern science, there are few more remarkable than those which relate to the production of harmonic sounds. We are all familiar with the effects of musical instruments, from the deep-toned voice of the organ to the wiry shrill of the Jew's harp. We sit entranced under their magical influence, whether the ear is charmed with the melody of their sounds, or the heart agitated by the sympathies which they rouse. But though we may admire their external form, and the skill of the artist who constructed them, we never think of inquiring into the cause of such extraordinary combinations.

Sounds of all kinds are conveyed to the organ of hearing through the air; and if this element were to be destroyed, all nature would be buried in the deepest silence. Noises of every variety, whether they are musical or discordant, high or low, move through the air of our atmosphere at the surface of the earth with a velocity of 1090 feet in a second, or 765 miles per hour; but in sulphurous acid gas sound moves only through 751 feet in a second, while in hydrogen gas it moves with the great velocity of 3000 feet. Along fluid and solid bodies, its progress is still more rapid. Through water it moves at the rate of 4708 feet in a second, through tin at the rate of 8175 feet, and through iron, glass, and some kinds of wood, at the rate of 18,530 feet.

When a number of single and separate sounds follow each other in rapid succession, they produce a continued sound, in the same manner as a continuous circle of light is produced by whirling round a burning stick before the eye. In order that the sound may appear a single one to the ear, nearly sixteen separate sounds must follow one another every second. When these sounds are exactly similar, and recur at equal intervals, they form a musical sound. In order to produce such sounds from the air, it must receive at least sixteen equally distant impulses or strokes in a second. The most common way of producing this effect is by a string or wire A B, Fig. 40, stretched between the fixed points A, B. If this string is taken by the middle and pulled aside, or if it is suddenly struck, it will vibrate between its two fixed points, as shown in the figure, passing alternately on each side of its axis A B, the vibrations gradually diminishing by the resistance of the air till the string is brought to rest. Its vibrations, however, may be kept up, by drawing a rosined fiddle-bow across it, and while it is vibrating it will give out a sound corresponding to the rapidity of its vibrations, and arising from the successive blows or impulses given to the air by the string. This sound is called the fundamental sound of the string, and its acuteness or sharpness increases with the number of vibrations which the string performs in a second.

Fig. 40.

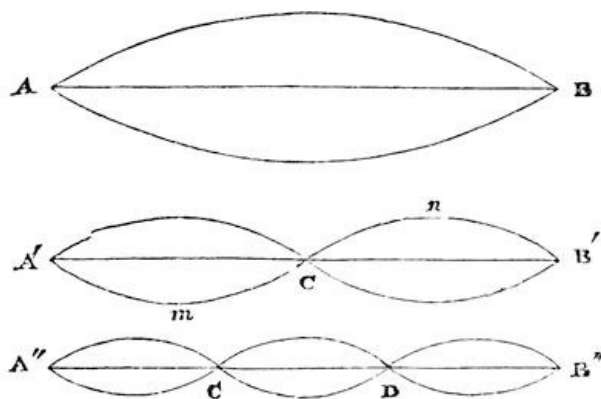

If we now touch the vibrating string A' B lightly with the finger, or with a feather at the middle point C, Fig. 40, it will give out a more acute but fainter sound than before, and while the extent of its vibrations is diminished, their frequency is doubled. In like manner, if we touch the string A'' B'', Fig. 40, at a point C, so that A'' C is one-third of A'' B'', the note will be still more acute, and correspond to thrice the number of vibrations. All this might have been expected; but the wonderful part of the experiment is, that the vibrating string A' B' divides itself at C into two parts A' C, C B', the part A' C vibrating round A and C as fixed points, and the part C B' round C and B', but always so that the part A' C is at the same distance on the one side of the axis A' B' as at A m C, while the part C B is on the other side, as at C n B. Hence the point C, being always pulled by equal and opposite forces, remains at rest as if it were absolutely fixed. This stationary point is called a *node*, and the vibrating portions A' m C, C n B' loops. The very same is true of the string A'' B'', the points C and D being stationary points; and upon the same principle a string may be divided into any number of vibrating portions. In order to prove that the string is actually vibrating in these equal subdivisions, we have only to place a piece of light paper with a notch in it on different parts of the string. At the nodes C and D it will remain perfectly at rest, while at m or n in the middle of the loops it will be thrown off or violently agitated.

The acute sounds given out by each of the vibrating portions are called *harmonic sounds*, and they accompany the fundamental sound of the string in the very same manner as we have already seen that the eye sees the accidental or harmonic colours while it is affected with the fundamental colour.

The subdivision of the string, and consequently the production of harmonic sounds, may be effected without touching the string at all, and by means of a sympathetic action conveyed by the air. If a string A B, for example, Fig. 40, is at rest, and if a shorter string A'' C, one third of its length, fixed at the two points A'' and C, is set vibrating in the same room, the string A B will be set vibrating in three loops like A'' B'', giving out the same harmonic sounds as the small string A'' C.

It is owing to this property of sounding bodies that singers with great power of voice are able to break into pieces a large tumbler glass, by singing close to it its proper fundamental note; and it is from the same sympathetic communication of vibrations that two pendulum clocks fixed to the same wall, or two watches lying upon the same table, will take the same rate of going, though they would not agree with one another if placed in separate apartments. Mr. Ellicott even observed that the pendulum of the one clock will stop that of the other, and that the stopped pendulum will, after a certain time, resume its vibrations, and in its turn stop the vibrations of the other pendulum.

The production of musical sounds by the vibrations of a column of air in a pipe is familiar to every person, but the extraordinary mechanism by which it is effected is known principally to philosophers. A column of air in a pipe may be set vibrating by blowing over the open end of it, as is done in Pan's pipes; or by blowing over a hole in its side, as in the flute; or by blowing through an aperture called a reed, with a flexible tongue, as in the clarionet. In order to understand the nature of this vibration, let AB, Fig. 41, be a pipe or tube, and let us place in it a spiral spring AB, in which the coil or spire are at equal distances, each end of the spiral being fixed to the end of the tube. This elastic spring may be supposed to represent the air in the pipe, which is of equal density throughout. If we take hold of the spring at *m*, and push the point *m* towards A and towards B in succession, it will give us a good idea of the vibration of an elastic column of air. When *m* is pushed towards A, the spiral spring will be compressed or condensed, as shown at *m* A, No. 2, while at the other end it will be dilated or rarefied, as shown at *m* B, and in the middle of the tube it will have the same degree of compression as in No. 1. When the string is drawn to the other end of the tube B, the spring will be, as in No. 3, condensed at the end B, and dilated at the end A. Now when a column of air vibrates in a pipe AB, the whole of it rushes alternately from B to A, as in No. 2, and from A to B as in No. 3, being condensed at the end A, No. 2, and dilated or rarefied at the end B, while in No. 3 it is rarefied at A and condensed at B, preserving its natural density at the middle point between A and B. In the case of the spring the ends AB are alternately pushed outwards and pulled inwards by the spring, the end A being pushed outwards in No. 2, and B pulled inwards, while in No. 3 A is pulled inwards and B pushed outwards.

Fig. 41.

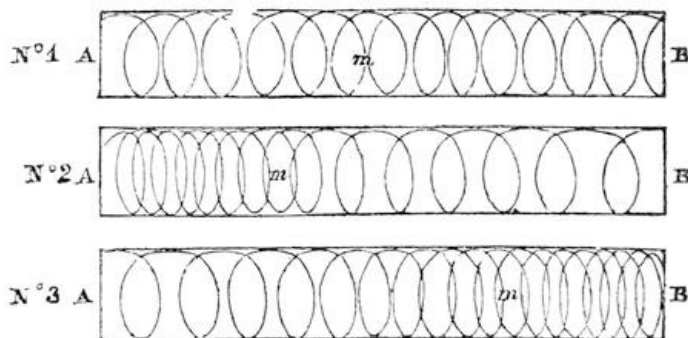

That the air vibrating in a pipe is actually in the state now described, may be shown by boring small holes in the pipe, and putting over them pieces of a fine membrane. The membrane opposite to the middle part between A and B where the particles of the air have the greatest motion, will be violently agitated, while at points nearer the ends A and B it will be less and less affected.

Fig. 42.

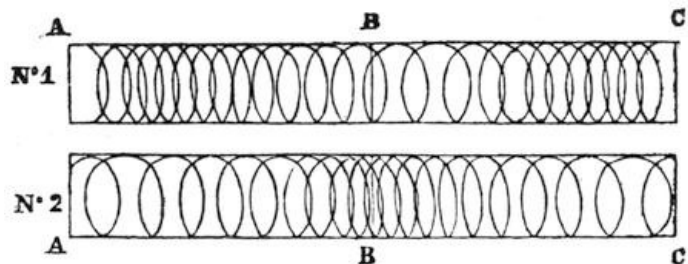

Let us now suppose two pipes, AB, BC, to be joined together as in Fig. 42, and to be separated by a fixed partition at B; and let a spiral spring be fixed in each. Let the spring AB be now pushed to the end A, while the spring BC is pushed to C, as in No. 1, and back again, as in No. 2, but always

in opposite directions; then it is obvious that the partition B is in No. 1 drawn in opposite directions towards A and towards C, and always with forces equal to each other: that is, when B is drawn slightly towards A, which it is at the beginning of the motion, it is also drawn slightly towards C; and when it is drawn forcibly towards A, as it is at the end of the motion of the spring, it is also drawn forcibly towards C. If the partition B, therefore, is moveable, it will still remain fixed during the opposite excursions of the spiral springs; nay, if we remove the partition, and hook the end of one spiral spring to the end of the other, the node or point of junction will remain stationary during the movements of the springs, because at every instant that point is drawn by equal and opposite forces. If *three, four, or five* spiral springs are joined in a similar manner, we may conceive them all vibrating between their nodes in the same manner.

Upon the very same principles we may conceive a long column of air without partitions dividing itself into two, three, or four smaller columns, each of which will vibrate between its nodes in the same manner as the spiral spring. At the middle point of each small vibrating column, the air will be of its natural density, like that of the atmosphere; while at the nodes B, &c. it will be in a state of condensation and rarefaction alternately.

If, when the air is vibrating in one column in the pipe AB, as in Fig. 41, No. 2, 3, we conceive a hole made in the middle, the atmospheric air will not rush in to disturb the vibration, because the air within the pipe and without it has exactly the same density. Nay, if, instead of a single hole, we were to cut a ring out of the pipe at the middle point, the column would vibrate as before. But if we bore a hole between the middle and one of the ends, where the vibrating column must be either in a state of condensation or rarefaction, the air must either rush out or rush in, in order to establish the equilibrium. The air opposite the hole will then be brought to the state of the external air, like that in the middle of the pipe; it will become the middle of a vibrating column: and the whole column of air, instead of vibrating as one, will vibrate as two columns, each column vibrating with twice the velocity, and yielding harmonic sounds along with the fundamental sound of the whole columns, in the same manner as we have already explained with regard to vibrating strings. By opening other holes we may subdivide a vibrating column into any number of smaller vibrating columns. The holes in flutes, clarionets, &c. are made for this purpose. When they are all closed up, the air vibrates in one column; and by opening and shutting the different holes in succession, the number of vibrating columns is increased or diminished at pleasure, and consequently the harmonic sounds will vary in a similar manner.

Curious as these phenomena are, they are still surpassed by those which are exhibited during the vibration of solid bodies. A rod or bar of metal or glass may be made to vibrate either longitudinally or laterally.

An iron rod will vibrate longitudinally, like a column of air, if we strike it at one end in the direction of its length; or rub it in the same direction with a wetted finger, and it will admit the same fundamental note as a column of air *ten or eleven* times as long, because sound moves so much faster in iron than in air. When the iron rod is thus vibrating along its length, the very same changes which we have shown in Fig. 41, as produced in a spiral spring, or in a column of air, take place in the solid metal. All its particles move alternately towards A and towards B, the metal being in the one case condensed at the end to which the particles move, and expanded at the end from which they move, and retaining its natural density in the middle of the rod. If we now hold this rod in the middle, by the finger and thumb lightly applied, and rub it in the middle either of AB or BC with a piece of cloth sprinkled with powdered rosin, or with a well-rosined fiddle-bow drawn across the rod, it will divide itself into two vibrating portions AB, BC, each of which will vibrate, as shown in Fig. 42, like the two adjacent columns of air, the section of the rod, or the particles which compose that section at B, being at perfect rest. By holding the rod at any intermediate point between A and B, so that the distance from A to the finger and thumb is one-third, one-fourth, one-fifth, &c. of the whole length AC, and rubbing one of the divisions in the middle, the rod will divide itself into 3, 4, 5, &c. vibrating portions, and give out corresponding harmonic sounds.

Fig. 43.

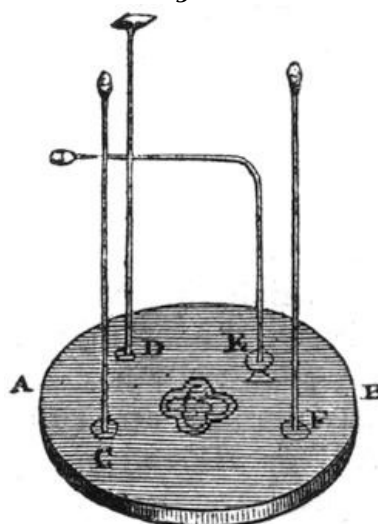

A rod of iron may be made to vibrate laterally or transversely, by fixing one end of it firmly, as in a vice, and leaving the other free, or by having both ends free or both fixed. When a rod, fixed at one end and free at the other, is made to vibrate, its mode of vibrating may be rendered evident to the eye; and for the purpose of doing this, Mr. Wheatstone has contrived a curious instrument, called the *Kaleidophone*, which is shown in Fig. 43. It consists of a circular base of wood AB, about *nine* inches in diameter and one inch thick, and having four brass sockets firmly fixed into it at C, D, E, and F. Into these sockets are screwed four vertical steel rods C, D, E, and F, about thirteen or fourteen inches long; one being a square rod, another a bent cylindrical one, and the other two cylindrical ones of different diameters. On the extremities of these rods are fixed small quicksilvered glass beads, either singly or in groups, so that when the instrument is placed in the light of the sun or in that of a lamp, bright images of the sun or flame are seen reflected on each bead. If any of these rods is set vibrating, these luminous images will form continuous and returning curve lines in a state of constant variation, each different rod giving curves of different characters, as shown in Fig. 44.

Fig. 44.

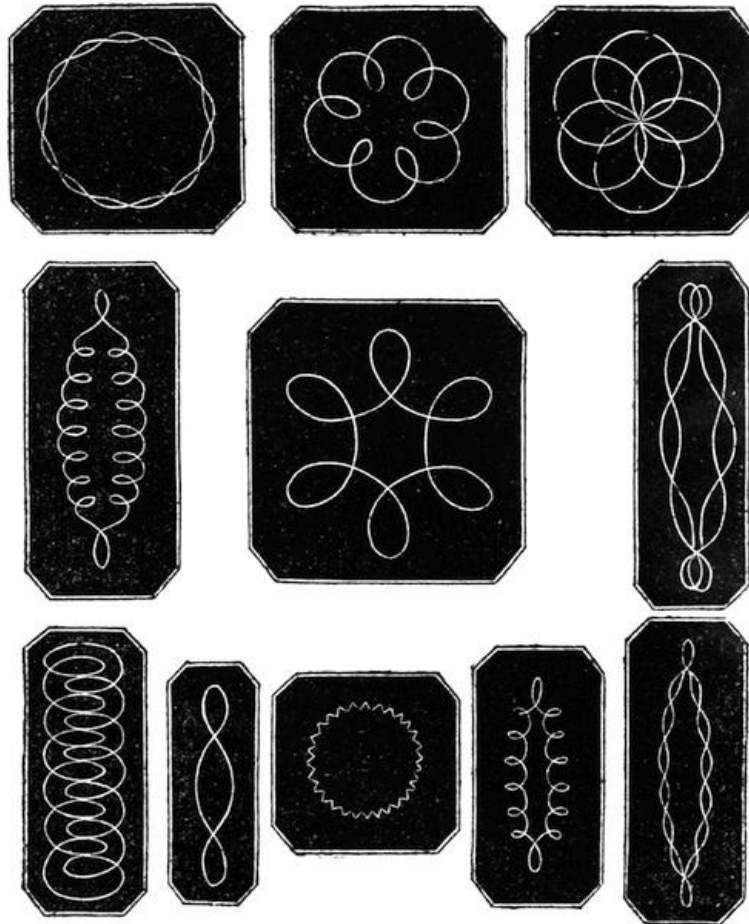

The Melodion, an instrument of great power, embracing five octaves, operates by means of the vibrations of metallic rods of unequal lengths, fixed at one end and free at the other.¹⁹ A narrow and thin plate of copper is screwed to the free extremity of each rod, and at right angles to its length; and its surface is covered with a small piece of felt, impregnated with rosin. This narrow band is placed near the circumference of a revolving cylinder, and, by touching the key, it is made to descend till it touches the revolving cylinder, and gives out its sound. The sweetness and power of this instrument are unrivalled; and such is the character of its tones, that persons of a nervous temperament are often entirely overpowered by its effects.

The vibrations of plates of metal or glass of various forms exhibit a series of the most extraordinary phenomena, which are capable of being shown by very simple means. These phenomena are displayed in an infinite variety of regular figures assumed by sand or fine lycopodium powder, strewed over the surface of the glass plate. In order to produce these figures, we must pinch or damp the plate at one or more places, and when the sand is strewed upon its surface, it is thrown into vibrations by drawing a fiddle-bow over different parts of its circumference. The method of damping or pinching plates is shown in Fig. 45. In No. 1, a square plate of glass AB, ground smooth at its edges, is pinched by the finger and thumb. In No. 2, a circular plate is held by the thumb against the top *c* of a perpendicular rod, and damped by the fingers at two different points of its circumference. In No. 3 it is damped at three points of its circumference; *c* and *d* by the thumb and finger, and at *e* by pressing it against a fixed obstacle *a* *b*. By means of a clamp like that at No. 4, it may be damped at a greater number of points.

Fig. 45.

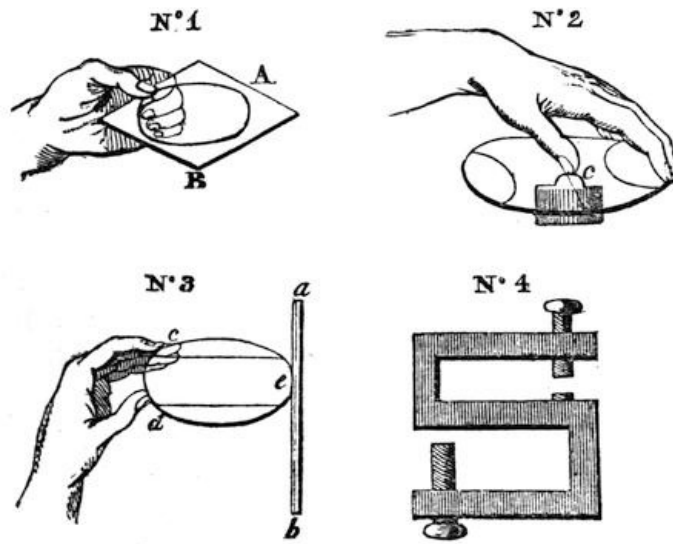
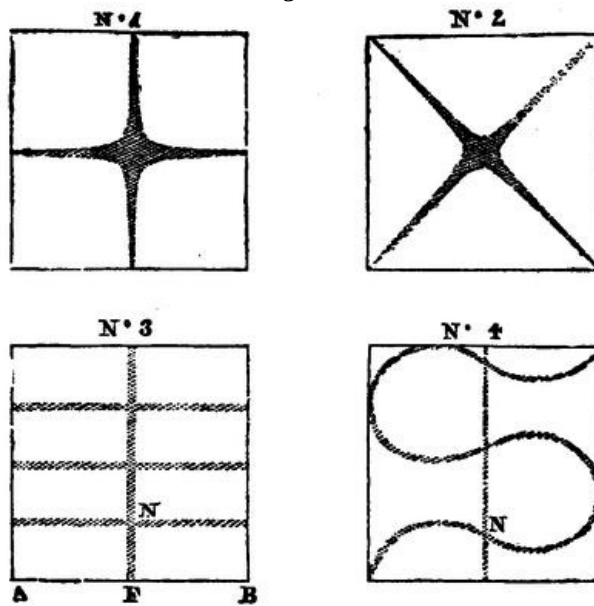

Fig. 46.



If we take a *square* plate of glass, such as that shown in Fig. 46, No. 1, and, pinching it at its centre, draw the fiddle-bow near one of its angles, the sand will accumulate in the form of a cross, as shown in the figure, being thrown off the parts of the plate that are in a state of vibration, and settling in the nodes or parts which are at rest. If the bow is drawn across the middle of one of the edges, the sand will accumulate as in No. 2. If the plate is pinched at N, No. 3, and the bow applied at F and perpendicular to AB, the sand will arrange itself in three parallel lines, perpendicular to a fourth passing through F and N. But if the point N, where it is pinched, is a little farther from the edge than in No. 3, the parallel lines will change into curves as in No. 4.

If the plate of glass is circular, and pinched at its centre, and also at a point of its circumference, and if the bow is applied at a point 45° from the last point, the figure of the sand will be as in Fig. 47, No. 1. If with the same plate, similarly pinched, the bow is drawn over a part 30° from the pinched point of the circumference, the sand will form six radii as in No. 2. When the centre of the plate is left free, a different set of figures is produced, as shown in No. 3 and No. 4. When the plate is pinched near its edge, and the bow applied 45° from the point pinched, a circle of sand will pass through that point, and two diameters of sand, at right angles to each other, will be formed as in No. 3. When a point of the circumference is pressed against a fixed obstacle, and the bow applied 30° from that point, the figure in No. 4 is produced.

Fig. 47.

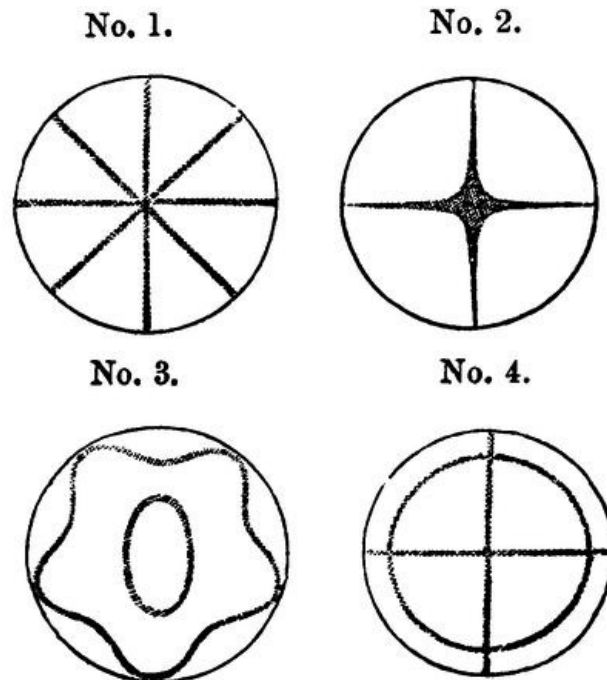

If, in place of a solid plate, we strew the sand over a stretched membrane, the sand will form itself into figures, even when the vibrations are communicated to the membrane through the air. In order to make these experiments, we must stretch a thin sheet of wet paper, such as vegetable paper, over the mouth of a tumbler-glass with a footstalk, and fix it to the edges with glue. When the paper is dry, a thin layer of dry sand is strewed upon its surface. If we place this membrane upon a table, and hold immediately above it, and parallel to the membrane, a plate of glass vibrating so as to give any of the figures shown in Fig. 47, the sand upon the membrane will imitate exactly the figure upon the glass. If the glass plate, in place of vibrating horizontally, is made to vibrate in an inclined position, the figures on the membrane will change with the inclination, and the sand will assume the most curious arrangements. The figures thus produced vary with the size of the membrane, with its material, its tension, and its shape. When the same figure occurs several times in succession, a breath upon the paper will change its degree of tension, and produce an entirely new figure, which, as the temporary moisture evaporates, will return to the original figure, through a number of intermediate ones. The pipe of an organ at the distance of a few feet, or the notes of a flute at the distance of half a foot, will arrange the sand on the membrane into figures which perpetually change with the sound that is produced.

The manner in which flat rulers and cylinders of glass perform their vibrations is very remarkable. If a glass plate about twenty-seven inches long, six-tenths of an inch broad, and six hundredths of an inch thick, is held by the edges between the finger and thumb, and has its lower surface, near either end, rubbed with a piece of wet cloth, sand laid upon its upper surface will arrange itself in parallel lines at right angles to the length of the plate. If the place of these lines is marked with a dot of ink, and the other side of the glass ruler is turned upwards, and the ruler made to vibrate as before, the sand will now accumulate in lines intermediate between the former lines, so that the motions of one-half the thickness of the glass ruler are precisely the reverse of those of the corresponding parts of the other half.

As these singular phenomena have not yet been made available by the scientific conjuror, we must be satisfied with this brief notice of them; but there is still one property of sound, which has its analogy also in light, too remarkable to be passed without notice. This property has more of the marvellous in it than any result within the wide range of the sciences. *Two loud sounds may be made to produce silence, and two strong lights may be made to produce darkness!*

If two equal and similar strings, or the columns of air in two equal and similar pipes, perform exactly 100 vibrations in a second, they will produce each equal waves of sound, and these waves will conspire in generating an uninterrupted sound, double of either of the sounds, heard separately. If the two strings or the two columns of air are not in unison, but nearly so, as in the case where the one vibrates 100 and the other 101 times in a second, then at the first vibration the two sounds will form one of double the strength of either; but the one will gradually gain upon the other, till at the fiftieth vibration it has gained half a vibration on the other. At this instant the two sounds will *destroy one another*, and an interval of perfect silence will take place. The sound will instantly commence, and gradually increase till it becomes loudest at the hundredth vibration, where the two vibrations conspire in producing a sound double of either. An interval of silence will again occur at the 150th, 250th, 350th vibration, or every second, while a sound of double the strength of either will be heard at the 200th, 300th, and 400th vibration. When the unison is very defective, or when there is a great difference between the number of vibrations which the two strings or columns of air perform in a second, the successive sounds and intervals of silence resemble a rattle. With a powerful organ, the effect of this experiment is very fine, the repetition of the sounds *wow—wow—wow*—representing the double sound and the interval of silence which arise from the total extinction of the two separate sounds.

The phenomenon corresponding to this in the case of light is perhaps still more surprising. If a

beam of *red* light issues from a luminous point, and falls upon the retina, we shall see distinctly the luminous object from which it proceeds; but if another pencil of red light issues from another luminous point, anyhow situated, provided the difference between its distance and that of the other luminous point from the point of the retina, on which the first beam fell, is the 258th thousandth part of an inch, or exactly *twice, thrice, four* times, &c., that distance; and if this second beam falls upon the same point of the retina, the one light will increase the intensity of the other, and the eye will see *twice* as much light as when it received only one of the beams separately. All this is nothing more than what might be expected from our ordinary experience. But if the difference in the distances of the two luminous points is only *one-half* of the 258th thousandth part of an inch, or $1\frac{1}{2}$, $2\frac{1}{2}$, $3\frac{1}{2}$, $4\frac{1}{2}$, times that distance, *the one light will extinguish the other and produce absolute darkness*. If the two luminous points are so situated, that the difference of their distances from the point of the retina is intermediate between 1 and $1\frac{1}{2}$, or 2 and $2\frac{1}{2}$, above the 258th thousandth part of an inch, the intensity of the effect which they produce will vary from absolute darkness to double the intensity of either light. At $1\frac{1}{4}$, $2\frac{1}{4}$, $3\frac{1}{4}$ times, &c., the 258th thousandth of an inch, the intensity of the two combined lights will be equal only to one of them acting singly. If the lights, in place of falling upon the retina, fall upon a sheet of white paper, the very same effect will be produced, a black spot being produced in the one case, and a bright white one in the other, and intermediate degrees of brightness in intermediate cases. If the two lights are *violet*, the difference of distances at which the preceding phenomena will be produced will be the 157th thousandth part of an inch, and it will be intermediate between the 258th and the 157th thousandth part of an inch for the intermediate colours. This curious phenomenon may be easily shown to the eye, by admitting the sun's light into a dark room through a small hole about the 40th or 50th part of an inch in diameter, and receiving the light on a sheet of paper. If we hold a needle or piece of slender wire in this light, and examine its shadow, we shall find that the shadow consists of bright and dark stripes succeeding each other alternately, the stripe in the very middle or axis of the shadow being a bright one. The rays of light which are bent into the shadow, and which meet in the very middle of the shadow, have exactly the same length of path, so that they form a bright fringe of double the intensity of either; but the rays which fall upon a point of the shadow at a certain distance from the middle, have a difference in the length of their paths, corresponding to the difference at which the lights destroy each other, so that a *black* stripe is produced on each side of the middle bright one. At a greater distance from the middle, the difference becomes such as to produce a bright stripe, and so on, a bright and a dark stripe succeeding each other to the margin of the shadow.

The explanation which philosophers have given of these strange phenomena is very satisfactory, and may be easily understood. When a wave is made on the surface of a still pool of water, by plunging a stone into it, the wave advances along the surface, while the water itself is never carried forward, but merely rises into a height and falls into a hollow, each portion of the surface experiencing an elevation and a depression in its turn. If we suppose two waves equal and similar to be produced by two separate stones, and if they reach the same spot at the same time, that is, if the two elevations should exactly coincide, they would unite their effects, and produce a wave twice the size of either; but if the one wave should be just so far before the other, that the hollow of the one coincided with the elevation of the other, and the elevation of the one with the hollow of the other, the two waves would obliterate or destroy one another, the elevation as it were of the one filling up half the hollow of the other, and the hollow of the one taking away half the elevation of the other, so as to reduce the surface to a level. These effects will be actually exhibited by throwing two equal stones into a pool of water, and it will be seen that there are certain lines of a hyperbolic form where the water is quite smooth, in consequence of the equal waves obliterating one another, while, in other adjacent parts, the water is raised to a height corresponding to both the waves united.

In the tides of the ocean we have a fine example of the same principle. The two immense waves arising from the action of the sun and moon upon the ocean produce our spring-tides by their combination, or when the elevations of each coincide; and our neap-tides, when the elevation of the one wave coincides with the depression of the other. If the sun and moon had exerted exactly the same force upon the ocean, or produced tide waves of the same size, then our neap-tides would have disappeared altogether, and the spring-tide would have been a wave double of the wave produced by the sun and moon separately. An example of the effect of the equality of the two waves occurs in the port of Batsha, where the two waves arrive by channels of different lengths, and actually obliterate each other.

Now, as sound is produced by undulations or waves in the air, and as light is supposed to be produced by waves or undulations in an ethereal medium, filling all nature, and occupying the pores of transparent bodies, the successive production of sound and silence by two loud sounds, or of light and darkness by two bright lights, may be explained in the very same manner as we have explained the increase and the obliteration of waves formed on the surface of water. If this theory of light be correct, then the breadth of a wave of *red* light will be the 258th thousandth part of an inch, the breadth of a wave of green light the 207th thousandth part of an inch, and the breadth of a wave of violet light the 157th thousandth part of an inch.

Among the wonders of modern skill, we must enumerate those beautiful automata by which the motions and actions of man and other animals have been successfully imitated. I shall therefore describe at present some of the most remarkable acoustic automata, in which the production of musical and vocal sounds has been the principal object of the artist.

Many very ingenious pieces of acoustic mechanism have been from time to time exhibited in

Europe. The celebrated Swiss mechanist, M. le Droz, constructed for the King of Spain the figure of a sheep, which imitated in the most perfect manner the bleating of that animal; and likewise the figure of a dog watching a basket of fruit, which, when any of the fruit was taken away, never ceased barking till it was replaced.

The singing-bird of M. Maillardet, which he exhibited in Edinburgh many years ago, is still more wonderful.²⁰ An oval box, about three inches long, was set upon the table, and in an instant the lid flew up, and a bird of the size of the humming-bird, and of the most beautiful plumage, started from its nest. After fluttering its wings, it opened its bill and performed four different kinds of the most beautiful warbling. It then darted down into its nest, and the lid closed upon it. The moving power in this piece of mechanism is said to have been springs which continued their action only four minutes. As there was no room within so small a figure for accommodating pipes to produce the great variety of notes which were warbled, the artist used only one tube, and produced all the variety of sounds by shortening and lengthening it with a moveable piston.

Ingenious as these pieces of mechanism are, they sink into insignificance when compared with the machinery of M. Vaucanson, which had previously astonished all Europe. His two principal automata were the flute-player, and the pipe and tabor-player. The flute-player was completed in 1736, and wherever it was exhibited it produced the greatest sensation. When it came to Paris it was received with great suspicion. The French savants recollected the story of M. Raisin, the organist of Troyes, who exhibited an automaton player upon the harpsichord, which astonished the French court by the variety of its powers. The curiosity of the king could not be restrained, and in consequence of his insisting upon examining the mechanism, there was found in the figure a pretty little musician five years of age. It was natural, therefore, that a similar piece of mechanism should be received with some distrust; but this feeling was soon removed by M. Vaucanson, who exhibited and explained to a committee of the Academy of Sciences the whole of the mechanism. This learned body was astonished at the ingenuity which it displayed; and they did not hesitate to state, that the machinery employed for producing the sounds of the flute performed in the most exact manner the very operations of the most expert flute-player, and that the artist had imitated the effects produced, and the means employed by nature, with an accuracy which exceeded all expectation. In 1738, M. Vaucanson published a memoir, approved of by the Academy, in which he gave a full description of the machinery employed, and of the principles of its construction. Following this memoir, I shall therefore attempt to give as popular a description of the automaton as can be done without lengthened details and numerous figures.

The body of the flute-player was about 5½ feet high, and was placed upon a piece of rock, surrounding a square pedestal 4½ feet high by 3½ feet wide. When the panel which formed the front of the pedestal was opened, there was seen on the right a clock movement, which, by the aid of several wheels, gave a rotatory motion to a steel axis about 2½ feet long, having cranks at six equidistant points of its length, but lying in different directions. To each crank was attached a cord, which descended and was fixed by its other end to the upper board of a pair of bellows, 2½ feet long and 6 inches wide. Six pair of bellows arranged along the bottom of the pedestal were then wrought, or made to blow in succession, by turning the steel axis.

At the upper face of the pedestal, and upon each pair of bellows is a double pulley, one of whose rims is 3 inches in diameter, and the other 1½. The cord which proceeds from the crank coils round the smaller of these pulleys, and that which is fixed to the upper board of the bellows goes round the larger pulley. By this means the upper board of the bellows is made to rise higher than if the cords went directly from them to the cranks.

Round the larger rims of three of these pulleys, viz. those on the right hand, there are coiled three cords, which, by means of several smaller pulleys, terminate in the upper boards of other three pair of bellows placed on the top of the box.

The tension of each cord when it begins to raise the board of the bellows to which it is attached, gives motion to a lever placed above it between the axis and the double pulley in the middle and lower region of the box. The other end of this lever keeps open the valve in the lower board of the bellows, and allows the air to enter freely, while the upper board is rising to increase the capacity of the bellows. By this means there is not only power gained, in so far as the air gains easier admission through the valve, but the fluttering noise produced by the action of the air upon the valves is entirely avoided, and the nine pair of bellows are wrought with great ease, and without any concussion or noise.

These nine bellows discharge their wind into three different and separate tubes. Each tube receives the wind of three bellows, the upper boards of one of the three pair being loaded with a weight of four pounds, those of the second three pair with a weight of two pounds, and those of the other three pair with no weight at all. These three tubes ascended through the body of the figure and terminated in three small reservoirs placed in its trunk. These reservoirs were thus united into one, which, ascending into the throat, formed by its enlargement the cavity of the mouth terminated by two small lips, which rested upon the whole of the flute. These lips had the power of opening more or less, and by a particular mechanism, they could advance or recede from the hole in the flute. Within the cavity of the mouth there is a small moveable tongue for opening and shutting the passage for the wind through the lips of the figure.

The motions of the fingers, lips, and tongue of the figure were produced by means of a revolving cylinder, thirty inches long and twenty-one in diameter. By means of pegs and brass staples fixed in fifteen different divisions in its circumference, fifteen different levers, similar to those in a

barrel organ, were raised and depressed. Seven of these regulated the motions of the seven fingers for stopping the holes of the flute, which they did by means of steel chains rising through the body, and directed by pulleys to the shoulder, elbow, and fingers. Other three of the levers communicating with the valves of the three reservoirs, regulated the ingress of the air, so as to produce a stronger or a weaker tone. Another lever opened the lips so as to give a free passage to the air, and another contracted them for the opposite purpose. A third lever drew them backwards from the orifice of the flute, and a fourth pushed them forward. The remaining lever enabled the tongue to stop up the orifice of the flute.

Such is a very brief view of the general mechanism by which the requisite motions of the flute-player were produced. The airs which it played were probably equal to those executed by a living performer, and its construction, as well as its performances, continued for many years to delight and astonish the philosophers and musicians of Europe.

Encouraged by the success of this machine, M. Vaucanson exhibited in 1741 other automata, which were equally, if not more, admired. One of these was the automaton duck, which performed all the motions of that animal, and not only ate its food, but digested it;²¹ and the other was his pipe and tabor-player, a piece of mechanism which required all the resources of his fertile genius. Having begun this machine before he was aware of its peculiar difficulties, he was often about to abandon it in despair, but his patience and his ingenuity combined, enabled him not only to surmount every difficulty, but to construct an automaton which performed complete airs, and greatly excelled the most esteemed performers on the pipe and tabor.

The figure stands on a pedestal, and is dressed like a dancing shepherd. He holds in one hand a flageolet, and in the other the stick with which he beats the tambourine as an accompaniment to the airs of the flageolet, about twenty of which it is capable of performing. The flageolet has only three holes, and the variety of its tones depends principally on a proper variation of the force of the wind, and on the different degrees with which the orifices are covered. These variations in the force of the wind required to be given with a rapidity which the ear can scarcely follow, and the articulation of the tongue was required for the quickest notes, otherwise the effect was far from agreeable. As the human tongue is not capable of giving the requisite articulations to a rapid succession of notes, and generally slurs over one-half of them, the automaton was thus able to excel the best performers, as it played complete airs with articulations of the tongue at every note.

In constructing this machine, M. Vaucanson observed that the flageolet must be a most fatiguing instrument for the human lungs, as the muscles of the chest must make an effort equal to fifty-six pounds in order to produce the highest notes. A single ounce was sufficient for the lowest notes: so that we may, from this circumstance, form an idea of the variety of intermediate effects required to be produced.

While M. Vaucanson was engaged in the construction of these wonderful machines, his mind was filled with the strange idea of constructing an automaton containing the whole mechanism of the circulation of the blood. From some birds which he made, he was satisfied of its practicability; but as the whole vascular system required to be made of elastic gum or caoutchouc, it was supposed that it could only be executed in the country where the caoutchouc tree was indigenous. Louis XVI. took a deep interest in the execution of this machine. It was agreed that a skilful anatomist should proceed to Guiana to superintend the construction of the blood-vessels, and the king had not only approved of, but had given orders for, the voyage. Difficulties, however, were thrown in the way, Vaucanson became disgusted, and the scheme was abandoned.

The two automata which we have described were purchased by Professor Bayreuss of Helmstadt; but we have not been able to learn whether or not they still exist.

Fig. 48.

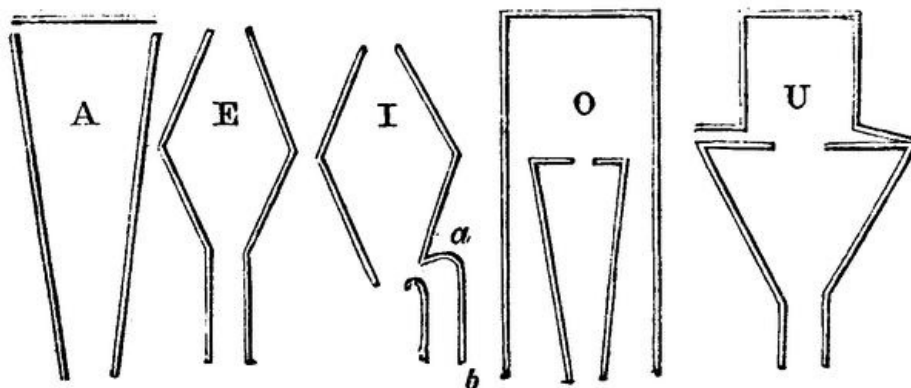

Towards the end of the eighteenth century a bold and almost successful attempt was made to construct a *talking automaton*. In the year 1779, the Imperial Academy of Sciences at St. Petersburg proposed, as the subject of one of their annual prizes, an inquiry into the nature of the vowel sounds, A, E, I, O, and U, and the construction of an instrument for artificially imitating them. This prize was gained by M. Kratzenstein, who showed that all the vowels could be distinctly pronounced by blowing through a reed into the lower ends of the pipes of the annexed figures, as shown in Fig. 48, where the corresponding vowels are marked on the different pipes.

The vowel I is pronounced by merely blowing into the pipe *a b*, of the pipe marked I, without the use of a reed.

Fig. 49.

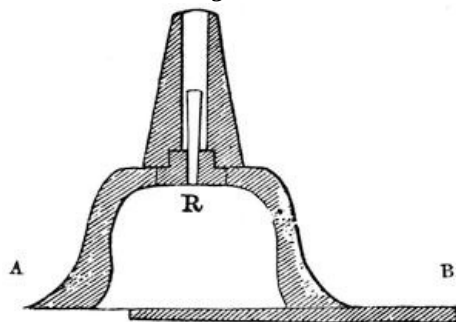

About the same time that Kratzenstein was engaged in these researches, M. Kempelen of Vienna, a celebrated mechanic, was occupied with the same subject. In his first attempt he produced the vowel sounds, by adapting a reed R, Fig. 49, to the bottom of a funnel-shaped cavity A B, and placing his hand in various positions within the funnel. This contrivance, however, was not fitted for his purpose, but after long study, and a diligent examination of the organs of speech, he contrived a hollow oval box, divided into two portions attached by a hinge so as to resemble jaws. This box received the sound which issued from the tube connected with the reed, and by opening and closing the jaws, he produced the sounds, A, O, OU, and an imperfect E, but no indications of an I. After two years' labour he succeeded in obtaining from different jaws the sounds of the consonants P, M, L, and by means of these vowels and consonants, he could compose syllables and words, such as *mama, papa, aula, lama, mulo*. The sounds of two adjacent letters, however, ran into each other, and an aspiration followed some of the consonants; so that, instead of *papa*, the word sounded *phaa-ph-a*; these difficulties he contrived with much labour to surmount, and he found it necessary to imitate the human organs of speech by having only one mouth and one glottis. The mouth consisted of a funnel, or bell-shaped piece of elastic gum, which approximated, by its physical properties, to the softness and flexibility of the human organs.²² To the mouth-piece was added a nose made of two tin tubes, which communicated with the mouth. When both these tubes were open, and the mouth-piece closed, a perfect M was produced; and when one was closed and the other open, an N was sounded. M. Kempelen could have succeeded in obtaining the four letters D, G, K, T, but, by using a P instead of them, and modifying the sound in a particular manner, he contrived to deceive the ear by a tolerable resemblance of these letters.

There seems to be no doubt that he at last was able to produce entire words and sentences, such as *opera, astronomy, Constantinopolis, Vous êtes mon ami, Je vous aime de tout mon cœur, Venez avec moi à Paris, Leopoldus secundus, Romanorum imperator semper Augustus, &c.*, but he never fitted up a speaking figure; and probably, from being dissatisfied with the general result of his labours, he exhibited only to his private friends the effects of the apparatus, which was fitted up in the form of a box.

This box was rectangular, and about three feet long, and was placed upon a table, and covered with a cloth. When any particular word was mentioned by the company, M. Kempelen caused the machine to pronounce it, by introducing his hands beneath the cloth, and apparently giving motion to some parts of the apparatus. Mr. Thomas Collinson, who had seen this machine in London, mentions, in a letter to Dr. Hutton, that he afterwards saw it at M. Kempelen's own house in Vienna, and that he then gave it the same word to be pronounced which he gave it in London, viz. the word *Exploitation*, which, he assures us, it again distinctly pronounced with the French accent.

M. Kratzenstein seems to have been equally unsuccessful; for though he assured M. de Lalande, when he saw him in Paris, in 1786, that he had made a machine which could speak pretty well, and though he showed him some of the apparatus by which it could sound the vowels, and even such syllables as *papa* and *mama*, yet there is no reason to believe that he had accomplished more than this.

The labours of Kratzenstein and Kempelen have been recently pursued with great success by our ingenious countryman, Mr. Willis, of Cambridge. In repeating Kempelen's experiment, shown in Fig. 49, he used a shallower cavity, such as that in Fig. 50, and found that he could entirely dispense with the introduction of the hand, and could obtain the whole series of vowels by sliding a flat board C D over the mouth of the cavity. Mr. Willis then conceived the idea of adapting to the reed cylindrical tubes, whose length could be varied by sliding joints. When the tube was greatly less than the length of a stopped pipe in unison with the reed, it sounded I, and by increasing the length of the tube, it gave E, A, O, and U, in succession. But what was very unexpected, when the tube was so much lengthened as to be $1\frac{1}{2}$ times the length of a stopped pipe in unison with the reed, the vowels began to be again sounded in an inverted order, viz. U, O, A, E, and then again in a direct order, I, E, A, O, U, when the length of the tube was equal to twice that of a stopped pipe, in unison with the reed.

Fig. 50.

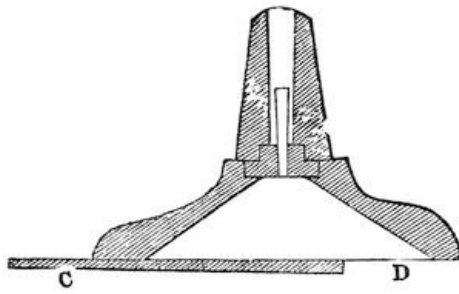

Some important discoveries have been recently made by M. Savart respecting the mechanism of the human voice;²³ and we have no doubt that, before another century is completed, a *Talking* and a *Singing machine* will be numbered among the conquests of Science.

LETTER IX.

Singular effects in nature depending on sound—Permanent character of speech—Influence of great elevations on the character of sounds, and on the powers of speech—Power of sound in throwing down buildings—Dog killed by sound—Sounds greatly changed under particular circumstances—Great audibility of sounds during the night explained—Sounds deadened in media of different densities—Illustrated in the case of a glass of champagne—and in that of new-fallen snow—Remarkable echoes—Reverberations of thunder—Subterranean noises—Remarkable one at the Solfaterra—Echo at the Menai suspension bridge—Temporary deafness produced in diving-bells—Inaudibility of particular sounds to particular ears—Vocal powers of the statue of Memnon—Sounds in granite rocks—Musical mountain of El-Nakous.

Although, among the phenomena of the material world, there is scarcely one which, when well considered, is not an object of wonder, yet those which we have been accustomed to witness from our infancy lose all their interest from the frequency of their occurrence, while to the natives of other countries they are unceasing objects of astonishment and delight. The inhabitant of a tropical climate is confounded at the sight of falling snow, and he almost discredits the evidence of his senses when he sees a frozen river carrying loaded waggons on its surface. The diffusion of knowledge by books, as well as by frequent communication between the natives of different quarters of the globe, has deprived this class of local wonders of their influence, and the Indian and the Scandinavian can visit each other's lands without any violent excitement of surprise. Still, however, there are phenomena of rare occurrence, of which no description can convey the idea, and which continue to be as deeply marked with the marvellous as if they had been previously unknown. Among these we may rank the remarkable modifications which sound undergoes in particular situations and under particular circumstances.

In the ordinary intercourse of life, we recognize individuals as much by their voice as by the features of their face and the form of their body. A friend who has been long absent will often stand before us as a stranger, till his voice supplies us with the full power of recognition. The brand imprinted by time on his outer form may have effaced the youthful image which the memory had cherished, but the original character of his voice and its yet remembered tones will remain unimpaired.

An old friend with a new face is not more common in its moral than in its physical acceptance; and though the sagacity of proverbial wisdom has not supplied us with the counterpart in relation to the human voice, yet the influence of its immutability over the mind has been recorded by the poet in some of his most powerful conceptions. When Manfred was unable to recognize in the hectic phantom of Astarte the endeared lineaments of the being whom he loved, the mere utterance of his name recalled "the voice which was his music," and invested her with the desired reality.

Say on, say on—
I live but in the sound—It is thy voice!
BYRON.

The permanence of character thus impressed upon speech exists only in those regions to whose atmosphere our vocal organs are adapted. If either the speaker or the hearer is placed in air differing greatly in density from that to which they are accustomed, the voice of the one will emit different sounds, or the same sounds will produce a different impression on the ear of the other. But if both parties are placed in this new atmosphere, their tones of communication will suffer the most remarkable change. The two extreme positions, where such effects become sufficiently striking, are in the compressed air of the diving-bell, when it is immersed to a great depth in the sea, or in the rarefied atmosphere which prevails on the summit of the Himalaya or the Andes.

In the region of common life, and even at the stillest hour of night, the ear seldom rests from its toils. When the voice of man and the bustle of his labours have ceased, the sounds of insect life are redoubled; the night breeze awakens among the rustling leaves, and the swell of the distant ocean, and the sounds of the falling cataract or of the murmuring brook, fill the air with their pure and solemn music. The sublimity of deep silence is not to be found even in the steppes of the Volga, or in the forests of the Orinoco. It can be felt only in those lofty regions

Where the tops of the Andes,
Shoot soaringly forth.

As the traveller rises above the limit of life and motion, and enters the region of habitual solitude, the death-like silence which prevails around him is rendered still more striking by the diminished density of the air which he breathes. The voice of his fellow traveller ceases to be heard even at a moderate distance, and sounds which would stun the ear at a lower level make but a feeble impression. The report of a pistol on the top of Mont Blanc is no louder than that of an Indian cracker. But while the thinness of the air thus subdues the loudest sounds, the voice itself undergoes a singular change: the muscular energy by which we speak experiences a great diminution, and our powers of utterance, as well as our power of hearing, are thus singularly modified. Were the magician, therefore, who is desirous to impress upon his victim or upon his pupil the conviction of his supernatural power, to carry him, under the injunction of silence,

----- to breathe
The difficult air of the iced mountain's top,
Where the birds dare not build, nor insect's wing
Flit o'er the herbless granite,

he would experience little difficulty in asserting his power over the elements, and still less in subsequently communicating the same influence to his companion.

But though the air at the tops of our highest mountains is scarcely capable of transmitting sounds of ordinary intensity, yet sounds of extraordinary power force their way through its most attenuated strata. At elevations where the air is three thousand times more rare than that which we breathe, the explosion of meteors is heard like the sound of cannon on the surface of the earth, and the whole air is often violently agitated by the sound. This fact alone may give us some idea of the tremendous nature of the forces which such explosions create, and it is fortunate for our species that they are confined to the upper regions of the atmosphere. If the same explosions were to take place in the dense air which rests upon the earth, our habitations and our lives would be exposed to the most imminent peril.

Buildings have often been thrown down by violent concussions of the air, occasioned either by the sound of great guns or by loud thunder, and the most serious effects upon human and animal life have been produced by the same cause. Most persons have experienced the stunning pain produced in the ear, when placed near a cannon that is discharged. Deafness has frequently been the result of such sudden concussions, and, if we may reason from analogy, death itself must often have been the consequence. When peace was proclaimed in London, in 1697, two troops of horse were dismounted and drawn up in line in order to fire their volleys. Opposite the centre of the line was the door of a butcher's shop, where there was a large mastiff dog of great courage. This dog was sleeping by the fire, but when the first volley was fired, it immediately started up, ran into another room, and hid itself under a bed. On the firing of the second volley, the dog rose, ran several times about the room trembling violently, and apparently in great agony. When the third volley was fired, the dog ran about once or twice with great violence and instantly fell down dead, throwing up blood from his mouth and nose.

Sounds of known character and intensity are often singularly changed even at the surface of the earth, according to the state of the ground and the conditions of the clouds. On the extended heath, where there are no solid objects capable of reflecting or modifying sound, the sportsman must frequently have noticed the unaccountable variety of sounds which are produced by the report of his fowling-piece. Sometimes they are flat and prolonged, at other times short and sharp, and sometimes the noise is so strange that it is referred to some mistake in the loading of the gun. These variations, however, arise entirely from the state of the air, and from the nature and proximity of the superjacent clouds. In pure air of uniform density the sound is sharp and soon over, as the undulations of the air advance without any interrupting obstacles. In a foggy atmosphere, or where the vapours produced by heat are seen dancing as it were in the air, the sound is dull and prolonged; and when these clouds are immediately over-head, a succession of echoes from them produces a continued or reverberating sound. When the French astronomers were determining the velocity of sound by firing great guns, they observed that the report was always single and sharp under a perfectly clear sky, but indistinct, and attended by a long-continued roll like thunder, when a cloud covered a considerable part of the horizon. It is no doubt owing to the same cause, namely, the reflexion from the clouds, that the thunder rolls through the heavens, as if it were produced by a succession of electric explosions.

The great audibility of sounds during the night is a phenomenon of considerable interest, and one which had been observed even by the ancients. In crowded cities or in their vicinity, the effect was generally ascribed to the rest of animated beings; while in localities where such an explanation was inapplicable, it was supposed to arise from a favourable direction of the prevailing wind. Baron Humboldt was particularly struck with this phenomenon when he first heard the rushing of the great cataracts of the Orinoco in the plain which surrounds the Mission of the Apures. These sounds he regarded as three times louder during the night than during the day. Some authors ascribed this fact to the cessation of the humming of insects, the singing of birds, and the action of the wind on the leaves of the trees, but M. Humboldt justly maintains that this cannot be the cause of it on the Orinoco, where the buzz of insects is much louder in the night than in the day, and where the breeze never rises till after sunset. Hence he was led to ascribe the phenomenon to the perfect transparency and uniform density of the air, which can exist only at night after the heat of the ground has been uniformly diffused through the atmosphere. When the rays of the sun have been beating on the ground during the day, currents of hot air of different temperatures, and consequently of different densities, are constantly ascending from the ground and mixing with the cold air above. The air thus ceases to be a homogeneous medium, and every person must have observed the effects of it upon objects seen through it which are very indistinctly visible, and have a tremulous motion, as if they were "dancing in the air." The very same effect is perceived when we look at objects through spirits and water that are not perfectly mixed, or when we view distant objects over a red-hot poker or over a flame. In all these cases the light suffers refraction in passing from a medium of one density into a medium of a different density, and the refracted rays are constantly changing their direction as the different currents rise in succession. Analogous effects are produced when sound passes through a mixed medium, whether it consists of two different mediums or of one medium where portions of it have different densities. As sound moves with different velocities through media of different densities, the wave which produces the sound will be partly reflected in

passing from one medium to the other, and the direction of the transmission wave changed: and hence in passing through such media different portions of the wave will reach the ear at different times, and thus destroy the sharpness and distinctness of the sound. This may be proved by many striking facts. If we put a bell in a receiver containing a mixture of hydrogen gas and atmospheric air, the sound of the bell can scarcely be heard. During a shower of rain or of snow, noises are greatly deadened; and when sound is transmitted along an iron wire or an iron pipe of sufficient length, we actually hear two sounds, one transmitted more rapidly through the solid, and the other more slowly through the air. The same property is well illustrated by an elegant and easily repeated experiment of Chladni's. When sparkling champagne is poured into a tall glass till it is half full, the glass loses its power of ringing by a stroke upon its edge, and emits only a disagreeable and puffy sound. This effect will continue while the wine is filled with bubbles of air, or as long as the effervescence lasts; but when the effervescence begins to subside the sound becomes clearer and clearer, and the glass rings as usual when the air-bubbles have vanished. If we reproduce the effervescence by stirring the champagne with a piece of bread, the glass will again cease to ring. The same experiment will succeed with other effervescing fluids.

The difference in the audibility of sounds that pass over homogeneous and over mixed media is sometimes so remarkable as to astonish those who witness it. The following fact is given on the evidence of an officer who observed it:—When the British and the American forces were encamped on each side of a river, the outposts were so near, that the form of individuals could be easily distinguished. An American drummer made his appearance, and began to beat his drum; but though the motion of his arms was distinctly seen, not a single sound reached the ear of the observer. A coating of snow that had newly fallen upon the ground, and the thickness of the atmosphere, had conspired to obstruct the sound. An effect the very reverse of this is produced by a coating of glazed or hardened snow, or by an extended surface of ice or water. Lieutenant Foster was able to carry on a conversation with a sailor across Port Bowen Harbour, a distance of no less than a mile and a quarter, and the sound of great guns has been heard at distances varying from 120 to 200 miles. Over hard and dry ground of a uniform character, or where a thin soil rests upon a continuous stratum of rock, the sound is heard at a great distance, and hence it is the practice among many Eastern tribes to ascertain the approach of an enemy by applying the ear to the ground.

Many remarkable phenomena in the natural world are produced by the reflexion and concentration of sound. Every person is familiar with the ordinary *echo* which arises from the reflexion of sound from an even surface, such as the face of a wall, of a house, of a rock, of a hill, or of a cloud. As sound moves at the rate of 1090 feet in a second, and as the sound which returns to the person who emits it has travelled over a space equal to twice his distance from the reflecting surface, the distance in feet of the body which occasions the echo may be readily found by multiplying 545 by the number of seconds which elapse between the emission of the sound and its return in the form of an echo. This kind of echo, where the same person is the speaker and the hearer, never takes place, unless when the observer is immediately in front of the reflecting surface, or when a line drawn from his mouth to the flat surface is nearly perpendicular to it, because in this case alone the wave of sound is reflected in the very same direction from the wall in which it reaches it. If the speaker places himself on one side of this line, then the echo will be heard most distinctly by another person as far on the other side of it, because the waves of sound are reflected like light, so that the angle of incidence or the inclination at which the sound falls upon the reflected surface is equal to the angle of reflexion, or the inclination at which the sound is returned from the wall. If two persons, therefore, are placed before the reflecting wall, the one will hear the echo of the sound emitted by the other, and obstacles may intervene between these two persons, so that neither of them hears the direct sound emitted by the other; in the same manner as the same persons similarly placed before a looking-glass would see each other distinctly by reflexion, though objects might obstruct their direct view of each other.

Hitherto we have supposed that there is only one reflecting surface, in which case there will be only one echo; but if there are several reflecting surfaces, as in the case in an amphitheatre of mountains, or during a thunder-storm, where there are several strata or masses of clouds; or if there are two parallel or inclined surfaces between which the sound can be repeatedly reflected, or if the surface is curved, so that the sound reflected from one part falls upon another part, like the sides of a polygon inscribed in a circle,—in all these cases there will be numerous echoes, which produce a very singular effect. Nothing can be more grand and sublime than the primary and secondary echoes of a piece of ordnance discharged in an amphitheatre of precipitous mountains. The direct or primary echoes from each reflecting surface reach the ear in succession, according to their different distances, and these are either blended with or succeeded by the secondary echoes, which terminate in a prolonged growl, ending in absolute silence. Of the same character are the reverberated claps of a thunderbolt reflected from the surrounding clouds, and dying away in the distance. The echo which is produced by parallel walls is finely illustrated at the Marquis of Simonetta's villa near Milan, which has been described by Addison and Keyser, and which we believe is that described by Mr. Southwell in the Philosophical Transactions for 1746. Perpendicular to the main body of this villa there extend two parallel wings about fifty-eight paces distant from each other, and the surfaces of which are unbroken either with doors or windows. The sound of the human voice, or rather a word quickly pronounced, is repeated above forty times, and the report of a pistol from fifty-six to sixty times. The repetitions, however, follow in such rapid succession that it is difficult to reckon them, unless early in the morning before the equal temperature of the atmosphere is disturbed, or in a calm, still evening. The echoes appear to be best heard from a window in the main building between

the two projecting walls, from which the pistol also is fired. Dr. Plot mentions an echo in Woodstock Park which repeats seventeen syllables by day and twenty by night. An echo on the north side of Shipley church, in Sussex, repeats twenty-one syllables. Sir John Herschel mentions an echo in the Manfroni palace at Venice, where a person standing in the centre of a square room about twenty-five feet high, with a concave roof, hears the stamp of his foot repeated a great many times; but as his position deviates from the centre, the echoes become feebler, and at a short distance entirely cease. The same phenomenon, he remarks, occurs in the large room of the library of the museum at Naples. M. Genefay has described, as existing near Rouen, a curious oblique echo which is not heard by the person who emits the sound. A person who sings hears only his own voice, while those who listen hear only the echo, which sometimes seems to approach, and at other times seems to recede from the ear; one person hears a single sound, another several sounds, and one hears it on the right, and another on the left, the effect always changing as the hearer changes his position. Dr. Birch has described an extraordinary echo at Roseneath, in Argyleshire, which certainly does not now exist. When eight or ten notes were played upon a trumpet, they were correctly repeated, but on a key a third lower. After a short pause, another repetition of the notes was heard in a still lower tone, and after another short interval they were repeated in a still lower tone.

In the same manner as light is always lost by reflexion, so the waves of sound are enfeebled by reflexion from ordinary surfaces, and the echo is in such cases fainter than the original sound. If the reflecting surface, however, is circular, sound may be condensed and rendered stronger in the same manner as light. I have seen a fine example of this, in the circular turn of a garden wall nearly a mile distant from a weir across a river. When the air is pure and homogeneous, the rushing sound of the water is reflected from the hollow surface of the wall, and concentrated in a focus, the place of which the ear can easily discover from the intensity of the sound being there a maximum. A person not acquainted with the locality conceives that the rushing noise is on the other side of the wall.

In whispering galleries, or places where the lowest whispers are carried to distances at which the direct sound is inaudible, the sound may be conveyed in two ways, either by repeated reflexions from a curved surface in the direction of the sides of a polygon inscribed in a circle, or where the whisperer is in the focus of one reflecting surface, and the hearer in the focus of another reflecting surface, which is placed so as to receive the reflected sounds. The first of these ways is exemplified in the whispering gallery of St. Paul's, and in the octagonal gallery of Gloucester cathedral, which conveys a whisper seventy-five feet across the nave; and the second in the baptistery of a church in Pisa, where the architect, Giovanni Pisano, is said to have constructed the cupola on purpose. The cupola has an elliptical form, and when one person whispers in one focus, it is distinctly heard by the person placed in the other focus, but not by those who are placed between them. The sound first reflected passes across the cupola, and enters the ears of the intermediate persons, but it is too feeble to be heard till it has been condensed by a second reflexion to the other focus of ellipse. A naval officer, who travelled through Sicily in the year 1824, gives an account of a powerful whispering place in the cathedral of Girgenti, where the slightest whisper is carried with perfect distinctness through a distance of two hundred and fifty feet, from the great western door to the cornice behind the high altar. By an unfortunate coincidence, the focus of one of the reflecting surfaces was chosen for the place of the confessional; and when this was accidentally discovered, the lovers of secrets resorted to the other focus, and thus became acquainted with confessions of the gravest import. This divulgence of scandal continued for a considerable time, till the eager curiosity of one of the dilettanti was punished, by hearing his wife's avowal of her own infidelity. This circumstance gave publicity to the whispering peculiarity of the cathedral, and the confessional was removed to a place of greater secrecy.

Fig. 51.



An echo of a very peculiar character has been described by Sir John Herschell in his Treatise on Sound, as produced by the suspension bridge across the Menai strait in Wales. "The sound of a blow with a hammer," says he, "on one of the main piers, is returned in succession from each of the cross-beams which support the road-way, and from the opposite pier at a distance of five hundred and seventy-six feet; and in addition to this, the sound is many times repeated between the water and the road-way. The effect is a series of sounds which may be thus written: the first return is sharp and strong from the road-way over-head; the rattling which succeeds dies away rapidly, but the single repercussion from the opposite pier is very strong, and is succeeded by a faint palpitation, repeating the sound at the rate of twenty-eight times in five seconds, and which, therefore corresponds to a distance of a hundred and eighty-four feet, or very nearly the double interval from the road-way to the water. Thus it appears that in the repercussion between the water and road-way, that from the latter only affects the ear, the line drawn from the auditor to the water being too oblique for the sound to diverge sufficiently in that direction. Another peculiarity deserves especial notice, namely, that the echo from the opposite pier is best heard when the auditor stands precisely opposite to the middle of the breadth of the pier, and strikes just on that point. As it deviates to one or the other side, the return is proportionally fainter, and is scarcely heard by him when his station is a little beyond the extreme edge of the pier, though

another person, stationed (on the same side of the water) at an equal distance from the central point, so as to have the pier between them, hears it well."

A remarkable subterranean echo is often heard when the hoofs of a horse or the wheels of a carriage pass over particular spots of ground. This sound is frequently very similar to that which is produced in passing over an arch or vault, and is commonly attributed to the existence of natural or artificial caves beneath. As such caves have often been constructed in times of war as places of security for persons and property, many unavailing attempts have been made to discover hidden treasures where their locality seemed to be indicated by subterraneous sounds. But though these sounds are sometimes produced by excavations in the ground, yet they generally arise from the nature of the materials of which the ground is composed, and from their manner of combination. If the hollow of a road has been filled up with broken rock, or with large waterworn stones, having hollows either left entirely empty, or filled up with materials of different density, then the sound will be reflected in passing from the loose to the dense materials, and there will arise a great number of echoes reaching the ear in rapid succession, and forming by their union a hollow rumbling sound. This principle has been very successfully applied by Sir John Herschell to explain the subterranean sounds with which every traveller is familiar who has visited the Solfaterra, near Naples. When the ground at a particular place is struck violently by throwing a large stone against it, a peculiar hollow sound is distinctly heard. This sound has been ascribed by some geologists to the existence of a great vault communicating with the ancient seat of the volcano, by other writers to a reverberation from the surrounding hills with which it is nearly concentric, and by others to the porosity of the ground. Dr. Daubeny, who says that the hollow sound is heard when any part of the Solfaterra is struck, accounts for it by supposing that the hill is not made up of one entire rock, but of a number of detached blocks, which, hanging as it were by each other, form a sort of vault over the abyss within which the volcanic operations are going on.²⁴ Mr. Forbes, who has given the latest and most interesting description of this singular volcano,²⁵ agrees in opinion with Dr. Daubeny; while Mr. Scrope²⁶ and Sir John Herschell concur in opinion that no such cavities exist. "It seems most probable," says the latter, "that the hollow reverberation is nothing more than an assemblage of partial echoes arising from the reflexion of successive portions of the original sound, in its progress through the soil at the innumerable half-coherent surfaces composing it: were the whole soil a mass of sand, these reflexions would be so strong and frequent as to destroy the whole impulse in too short an interval to allow of a distinguishable after-sound. It is a case analogous to that of a strong light thrown into a milky medium or smoky atmosphere; the whole medium appears to shine with a nebulous undefined light. This is to the eye what such a hollow sound is to the ear."²⁷

It has been recently shown by M. Savart, that the human ear is so extremely sensible as to be capable of appreciating sounds which arise from about *twenty-four thousand* vibrations in a second, and consequently that it can hear a sound which lasts only the twenty-four thousandth part of a second. Vibrations of such frequency afford only a shrill squeak or chirp; and Dr. Wollaston has shown that there are many individuals with their sense of hearing entire, who are altogether insensible to such acute sounds, though others are painfully affected by them. Nothing, as Sir John Herschell remarks, can be more surprising than to see two persons, neither of them deaf, the one complaining of the penetrating shrillness of a sound, while the other maintains there is no sound at all. Dr. Wollaston has also shown that this is true also of very grave sounds; so that the hearing or not hearing of musical notes at both extremities of the scale seems to depend wholly on the pitch or frequency of vibration constituting the note, and not upon the intensity or loudness of the noise. This affection of the ear sometimes appears in cases of common deafness, where a shrill tone of voice, such as that of women and children, is often better heard than the loud and deeper tone of men.

Dr. Wollaston remarked, that when the mouth and nose are shut, the tympanum or drum of the ear may be so exhausted by a forcible attempt to take breath by the expansion of the chest, the pressure of the external air upon the membrane gives it such a tension, that the ear becomes insensible to grave tones, without losing in any degree the perception of sharper sounds. Dr. Wollaston found, that after he had got into the habit of making the experiment, so as to be able to produce a great degree of exhaustion, his ears were insensible to all sounds below F, marked by the bass clef. "If I strike the table before me," says he, "with the end of my finger, the whole board sounds with a deep dull note. If I strike it with my nail, there is also at the same time a sharp sound produced by quicker vibrations of parts around the point of contact. When the ear is exhausted, it hears only the latter sound, without perceiving in any degree the deeper note of the whole table. In the same manner, in listening to the sound of a carriage, the deeper rumbling noise of the body is no longer heard by an exhausted ear; but the rattle of a chain or loose screw remains at least as audible as before exhaustion." Dr. Wollaston supposes that this excessive tension of the drum of the ear, when produced by the compressed air in the diving-bell, will also produce a corresponding *deafness to low tones*. This curious experiment has been since made by Dr. Colladon, when descending in the diving-bell at Howth, in 1820. "We descended," says he, "so slowly that we did not notice the motion of the bell; but as soon as the bell was immersed in water, we felt about the ears and the forehead a sense of pressure, which continued increasing during some minutes. I did not, however, experience any pain in the ears; but my companion suffered so much that we were obliged to stop our descent for a short time. To remedy that inconvenience, the workmen instructed us, after having closed our nostrils and mouth, to endeavour to swallow, and to restrain our respiration for some moments, in order that, by this exertion, the internal air might act on the Eustachian tube. My companion, however, having tried

it, found himself very little relieved by this remedy. After some minutes, we resumed our descent. My friend suffered considerably; he was pale; his lips were totally discoloured; his appearance was that of a man on the point of fainting; he was in involuntary low spirits, owing, perhaps, to the violence of the pain, added to that kind of apprehension which our situation unavoidably inspired. This appeared to me the more remarkable, as my case was totally the reverse. I was in a state of excitement resembling the effect of some spirituous liquor. I suffered no pain; I experienced only a strong pressure round my head, as if an iron circle had been bound about it. I spoke with the workmen, and had some difficulty in hearing them. This difficulty of hearing rose to such a height, that during three or four minutes I could not hear them speak. I could not, indeed, hear myself speak, though I spoke as loudly as possible; nor did even the great noise caused by the violence of the current against the sides of the bell reach my ears."

The effect thus described by Dr. Colladon is different from that anticipated by Dr. Wollaston. He was not merely deaf to low tones, but to all sounds whatever; and I have found, by repeated experiment, that my own ears become perfectly insensible even to the shrill tones of the female voice, and of the voice of a child, when the drum of the ear is thrown into a state of tension by yawning.

With regard to sounds of high pitch at the other extremity of the scale, Dr. Wollaston has met with persons, whose hearing was in other respects perfect, who never heard the chirping of the *Gryllus campestris*, which commonly occurs in hedges during a summer's evening, or that of the house-cricket, or the squeak of the bat, or the chirping of the common house-sparrow. The note of the bat is a full octave higher than that of the sparrow; and Dr. Wollaston believes that the note of some insects may reach one octave more, as there are sounds decidedly higher than that of a small pipe, one-fourth of an inch in length, which he conceives cannot be far from six octaves above the middle E of the pianoforte. "The suddenness of the transition," says Dr. Wollaston, "from perfect hearing to total want of perception, occasions a degree of surprise, which renders an experiment on this subject with a series of small pipes among several persons rather amusing. It is curious to observe the change of feeling manifested by various individuals of the party, in succession, as the sounds approach and pass the limits of their hearing. Those who enjoy a temporary triumph are often compelled in their turn to acknowledge to how short a distance their little superiority extends." In concluding his interesting paper on this subject, Dr. Wollaston conjectures that animals, like the grylli (whose powers of hearing appear to commence nearly where ours terminate), may have the power of hearing still sharper sounds which at present we do not know to exist, and that there may be other insects having nothing in common with us, but who are endowed with a power of exciting, and a sense of perceiving, vibrations which make no impression upon our organs, while their organs are equally insensible to the slower vibrations to which we are accustomed.

With the view of studying the class of sounds inaudible to certain ears, we would recommend it to the young naturalist to examine the sounds emitted by the insect tribe, both in relation to their effect upon the human ear, and to the mechanism by which they are produced. The Cicadæ or locusts in North America appear, from the observations of Dr. Hildreth,²⁸ to be furnished with a bagpipe on which they play a variety of notes. "When any one passes," says he, "they make a great noise and screaming with their air bladder or bagpipes. These bags are placed under, and rather behind, the wings in the axilla, something in the manner of using the bagpipes with the bags under the arms—I could compare them to nothing else; and, indeed, I suspect the first inventor of the instrument borrowed his ideas from some insect of this kind. They play a variety of notes and sounds, one of which nearly imitates the scream of the tree toad."

Among the acoustic wonders of the natural world may be ranked the vocal powers of the statue of Memnon, the son of Aurora, which modern discoveries have withdrawn from among the fables of ancient Egypt. The history of this remarkable statue is involved in much obscurity. Although Strabo affirms that it was overturned by an earthquake, yet as Egypt exhibits no traces of such a convulsion, it has been generally believed that the statue was mutilated by Cambyses. Ph. Casselius, in his dissertation on vocal or speaking stones, quotes the remark of the scholiast in Juvenal, "that, when mutilated by Cambyses, the statue, which saluted both the sun and the king, afterwards saluted only the sun." Philostratus, in his life of Apollo, informs us, that the statue looked to the east, and that it spoke as soon as the rays of the rising sun fell upon its mouth. Pausanias, who saw the statue in its dismantled state, says, that it is a statue of the sun, that the Egyptians call it Phamenophis, and not Memnon, and *that it emits sounds every morning at sunrise, which can be compared only to that of the breaking of the string of the lyre*. Strabo speaks only of a single sound which he heard; but Juvenal, who had probably heard it often during his stay in Egypt, describes it as if it emitted several sounds:

Dimidio magicæ resonant ubi Memnone chordæ.
Where broken Memnon sounds his magic strings.

The simple sounds which issued from the statue were, in the progress of time, magnified into intelligible words, and even into an oracle of seven verses, and this prodigy has been recorded in a Greek inscription on the left leg of the statue. But though this new faculty of the colossus was evidently the contrivance of the Egyptian priests, yet we are not entitled from this to call in question the simple and perfectly credible fact that it emitted sounds. This property, indeed, it seems to possess at the present day; for we learn,²⁹ that an English traveller, Sir A. Smith, accompanied with a numerous escort, examined the statue, and that at six o'clock in the morning he heard very distinctly the sounds which had been so celebrated in antiquity. He asserts that

this sound does not proceed from the statue, but from the pedestal; and he expresses his belief that it arises from the impulse of the air upon the stones of the pedestal, which are arranged so as to produce this surprising effect. This singular description is, to a certain extent, confirmed by the description of Strabo, who says, that he was quite certain that he heard a sound which proceeded either *from the base*, or from the colossus, or from some one of the assistants. As there were no Egyptian priests in the escort of Sir A. Smith, we may now safely reject this last, and, for many centuries, the most probable hypothesis.

The explanation suggested by Sir A. Smith had been previously given in a more specific form by M. Dussaulx, the translator of Juvenal. "The statue," says he, "being hollow, the heat of the sun heated the air which it contained, and this air, issuing at some crevice, produced the sounds of which the priests gave their own interpretation."

Rejecting this explanation, M. Langles, in his dissertation on the vocal statue of Memnon, and M. Salverte, in his work on the occult sciences, have ascribed the sounds entirely to Egyptian priestcraft; and have even gone so far as to describe the mechanism by which the statue not only emitted sounds, but articulated distinctly the intonations appropriate to the seven Egyptian vowels, and consecrated to the seven planets. M. Langles conceives that the sounds may be produced by a series of hammers, which strike either the granite itself, or sonorous stones like those which have been long used in China for musical instruments. M. Salverte improves this imperfect apparatus, by supposing that there might be adapted to these hammers a clepsydra, or water-clock, or any other instrument fitted to measure time, and so constructed as to put the hammers in motion at sunrise. Not satisfied with this supposition, he conjectures that the spring of all this mechanism was to be found in the art of concentrating the rays of the sun, which was well known to the ancients. Between the lips of the statue, or in some less remarkable part of it concealed from view by its height, he conceives an aperture to be perforated, containing a lens or a mirror capable of condensing the rays of the rising sun upon one or more metallic levers, which by their expansion put in motion the seven hammers in succession. Hence he explains why the sounds were emitted only at sunrise, and when the solar rays fell upon the mouth of the statue, and why they were never again heard till the sun returned to the eastern horizon. As a piece of mechanism, this contrivance is defective in not providing for the change in the sun's amplitude, which is very considerable even in Egypt, for as the statue and the lens are both fixed, and as the sounds were heard at all seasons of the year, the same lens which threw the Midsummer rays of the sun upon the hammers could not possibly throw upon them his rays in winter. But even if the machinery were perfect, it is obvious that it could not have survived the mutilation of the statue, and could not, short of a miracle, have performed its part in the time of Sir A. Smith.

If we abandon the idea of the whole being a trick of the priesthood, which has been generally done, and which the recent observations of Sir A. Smith authorise us to do, we must seek some natural cause for the phenomena similar to that suggested by Dussaulx. It is curious to observe how the study of nature gradually dispels the consecrated delusions of ages, and reduces to the level of ordinary facts what time had invested with all the characters of the supernatural: and in the present case it is no less remarkable that the problem of the statue of Memnon should have been first solved by means of an observation made by a solitary traveller wandering on the banks of the Orinoco. "The granitic rock," says Baron Humboldt, "on which we lay, is one of those where travellers on the Orinoco have heard from time to time, towards sunrise, subterraneous sounds resembling those of the organ. The missionaries call these stones *loxas de musica*. 'It is witchcraft,' said our young Indian pilot. We never ourselves heard these mysterious sounds either at Carichana Vieja or in the upper Orinoco: but from information given us by witnesses worthy of belief, the existence of a phenomenon that seems to depend on a certain state of the atmosphere cannot be denied. The shelves of rock are full of very narrow and deep crevices. They are heated during the day to about 50°. I often found their temperature at the surface during the night at 39°, the surrounding atmosphere being at 28°. It may easily be conceived that the difference of temperature between the subterraneous and the external air attains its maximum about sunrise, or at that moment which is at the same time farther from the period of the maximum of the heat of the preceding day. May not these sounds of an organ, then, which are heard when a person sleeps upon the rock, his ear in contact with the stone, be the effect of a current of air that issues out through the crevices? Does not the impulse of the air against the elastic spangles of mica that intercept the crevices contribute to modify the sounds? May we not admit that the ancient inhabitants of Egypt, in passing incessantly up and down the Nile, had made the same observation on some rock of the Thebaid, and that the music of the rocks there led to the jugglery of the priests in the statue of Memnon?"

This curious case of the production of sounds in granite rocks at sunrise might have been regarded as a transatlantic wonder which was not applicable to Egypt; but by a singular coincidence of observation, Messrs. Jomard, Jollois, and Devilliers, who were travelling in Egypt nearly about the same time that M. Humboldt was traversing the wilds of South America, heard, *at sunrise, in a monument of granite*, situated near the centre of the spot on which the palace of Carnac stands, *a noise resembling that of a breaking string*, the very expression by which Pausanias characterizes the sound in the Memnonian granite. The travellers regarded these sounds as arising from the transmission of rarefied air through the crevices of a sonorous stone, and they were of the same opinion with Humboldt, that these sounds might have *suggested* to the Egyptian priests *the juggleries of the Memnonium*. Is it not strange that the Prussian and the French travellers should not have gone a step farther, and solved the problem of two thousand years, by maintaining that the sound of the statue of Memnon was itself a natural phenomenon, or a granitic sound elicited at sunrise by the very same causes which operated on the Orinoco

and in the temple of Carnac, in place of regarding it as a trick in imitation of natural sounds? If, as Humboldt supposes, the ancient inhabitants of Egypt had, in passing incessantly up and down the Nile, become familiar with the music of the granite rocks of the Thebaid, how could the imitation of such natural and familiar sounds be regarded by the priests as a means of deceiving the people? There could be nothing marvellous in a colossal statue of granite giving out the very same sounds that were given out at the same time of the day by a granite rock; and in place of reckoning it a supernatural fact, they could regard it in no other light than as the duplicate of a well-known natural phenomenon. It is a mere conjecture, however, that such sounds were common in the Thebaid; and it is therefore probable that a granite rock, possessing the property of emitting sounds at sunrise, had been discovered by the priests, who were at the same time the philosophers of Egypt, and that the block had been employed in the formation of the Memnonian statue for the purpose of impressing upon it a supernatural character, and enabling them to maintain their influence over a credulous people.

The inquiries of recent travellers have enabled us to corroborate these views, and to add another remarkable example of the influence of subterraneous sounds over superstitious minds. About three leagues to the north of Tor in Arabia Petræa, is a mountain, within the bosom of which the most singular sounds have been heard. The Arabs of the Desert ascribe these sounds to a convent of monks preserved miraculously underground; and the sound is supposed to be that of the *Nakous*, a long narrow metallic ruler suspended horizontally, which the priest strikes with a hammer for the purpose of assembling the monks to prayer. A Greek was said to have seen the mountain open, and to have descended into the subterranean convent, where he found fine gardens and delicious water; and, in order to give proof of his descent, he produced some fragments of consecrated bread, which he pretended to have brought from the subterranean convent. The inhabitants of Tor likewise declare that the camels are not only frightened, but rendered furious, when they hear these subterraneous sounds.

M. Seetzen, the first European traveller who visited this extraordinary mountain, set out from Wodyel Nackel on the 17th of June, at five o'clock in the morning. He was accompanied by a Greek Christian and some Bedouin Arabs, and after a quarter of an hour's walk they reached the foot of a majestic rock of hard sand-stone. The mountain itself was quite bare and entirely composed of it. He found inscribed upon the rock several Greek and Arab names, and also some Koptic characters, which proved that it had been resorted to for centuries. About noon the party reached the foot of the mountains called *Nakous*, where at the foot of a ridge they beheld an insulated peaked rock. This mountain presented upon two of its sides two sandy declivities about 150 feet high, and so inclined that the white and slightly adhering sand which rests upon its surface is scarcely able to support itself; and when the scorching heat of the sun destroys its feeble cohesion, or when it is agitated by the smallest motions, it slides down the two declivities. These declivities unite behind the insulated rock, forming an acute angle, and like the adjacent surfaces, they are covered with steep rocks which consist chiefly of a white and friable free-stone.

The first sound which greeted the ears of the travellers took place at an hour and a quarter after noon. They had climbed with great difficulty as far as the sandy declivity, a height of seventy or eighty feet, and had rested beneath the rocks where the pilgrims are accustomed to listen to the sounds.

While in the act of climbing, M. Seetzen heard the sound from beneath his knees, and hence he was led to think that the sliding of the sand was the cause of the sound, and not the effect of the vibration which it occasioned. At three o'clock the sound became louder and continued six minutes, and after having ceased for ten minutes, it was again heard. The sound appeared to have the greatest resemblance to that of the humming-top, rising and falling like that of an Æolian harp. Believing that he had discovered the true origin of the sound, M. Seetzen was anxious to repeat the experiment, and with this view he climbed with the utmost difficulty to the highest rocks, and sliding down as fast as he could, he endeavoured, with the help of his hands and feet, to set the sand in motion. The effect thus produced far exceeded his expectations, and the sand in rolling beneath him made so loud a noise, that the earth seemed to tremble to such a degree that he states he should certainly have been afraid if he had been ignorant of the cause.

M. Seetzen throws out some conjectures respecting the cause of these sounds. Does the rolling layer of sand, says he, act like the fiddle-bow, which, on being rubbed upon a plate of glass, raises and distributes into regular figures the sand with which the plate is covered? Does the adherent and fixed layer of sand perform here the part of the plate of glass, and the neighbouring rocks that of the sounding body? We cannot pretend to answer these questions, but we trust that some philosopher competent to the task will have an opportunity of examining these interesting phenomena with more attention, and describing them with greater accuracy.

The only person, so far as I can learn, who has visited El-Nakous, since the time of Seetzen, is Mr. Gray, of University College, Oxford; but he has not added much to the information acquired by his predecessor. During the first visit which he made to the place, he heard at the end of a quarter of an hour a low continuous murmuring sound beneath his feet, which gradually changed into pulsations as it became louder, so as to resemble the striking of a clock, and at the end of five minutes it became so strong as to detach the sand. Returning to the spot next day, he heard the sound still louder than before. He could not observe any crevices by which the external air could penetrate; and as the sky was serene and the air calm, he was satisfied that the sounds could not arise from this cause.³⁰

LETTER X.

Mechanical inventions of the ancients few in number—Ancient and modern feats of strength—Feats of Eckeberg particularly described—General explanation of them—Real feats of strength performed by Thomas Topham—Remarkable power of lifting heavy persons when the lungs are inflated—Belzoni's feat of sustaining pyramids of men—Deception of walking along the ceiling in an inverted position—Pneumatic apparatus in the foot of the house-fly for enabling it to walk in opposition to gravity—Description of the analogous apparatus employed by the gecko lizard for the same purpose—Apparatus used by the *Echneis remora*, or sucking-fish.

The mechanical knowledge of the ancients was principally theoretical, and though they seem to have constructed some minor pieces of mechanism which were sufficient to delude the ignorant, yet there is no reason for believing that they had executed any machinery that was capable of exciting much surprise, either by its ingenuity or its magnitude. The properties of the mechanical powers, however, seem to have been successfully employed in performing feats of strength which were beyond the reach even of strong men, and which could not fail to excite the greatest wonder when exhibited by persons of ordinary size.

Firmus, a native of Seleucia, who was executed by the Emperor Aurelian for espousing the cause of Zenobia, was celebrated for his feats of strength. In his account of the life of Firmus, who lived in the third century, Vopiscus informs us, that he could suffer iron to be forged upon an anvil placed upon his breast. In doing this he lay upon his back, and resting his feet and shoulders against some support, his whole body formed an arch, as we shall afterwards more particularly explain. Until the end of the sixteenth century, the exhibition of such feats does not seem to have been common. About the year 1703, a native of Kent, of the name of Joyce, exhibited such feats of strength in London and other parts of England, that he received the name of the second Samson. His own personal strength was very great; but he had also discovered, without the aid of theory, various positions of his body in which men even of common strength could perform very surprising feats. He drew against horses, and raised enormous weights; but as he actually exhibited his power in ways which evinced the enormous strength of his own muscles, all his feats were ascribed to the same cause. In the course of eight or ten years, however, his methods were discovered, and many individuals of ordinary strength exhibited a number of his principal performances, though in a manner greatly inferior to Joyce.

Some time afterwards, John Charles Van Eckeberg, a native of Harzgerode, in Anhalt, travelled through Europe under the appellation of Samson, exhibiting very remarkable examples of his strength. This, we believe, is the same person whose feats are particularly described by Dr. Desaguliers. He was a man of the middle size, and of ordinary strength; and as Dr. Desaguliers was convinced that his feats were exhibitions of skill and not of strength, he was desirous of discovering his methods, and with this view he went to see him, accompanied by the Marquis of Tullibardine, Dr. Alexander Stuart, and Dr. Pringle, and his own mechanical operator. They placed themselves round the German, so as to be able to observe accurately all that he did, and their success was so great that they were able to perform most of the feats the same evening by themselves, and almost all the rest when they had provided the proper apparatus. Dr. Desaguliers exhibited some of the experiments before the Royal Society, and has given such a distinct explanation of the principles on which they depend, that we shall endeavour to give a popular account of them.

Fig. 52.

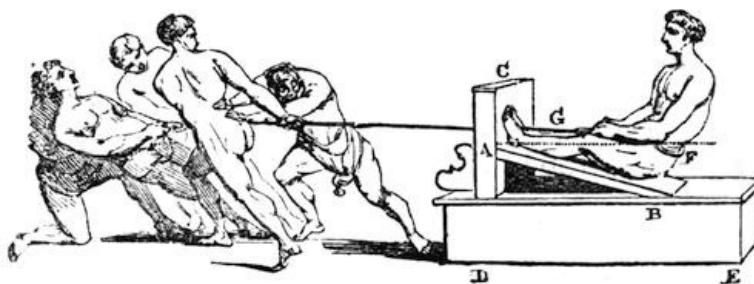

1. The performer sat upon an inclined board A B, placed upon a frame C D E, with his feet abutting against the upright board C. Round his loins was placed a strong girdle F G, to the iron ring of which at G was fastened a rope by means of a hook. The rope passed between his legs through a hole in the board C, and several men or two horses, pulling at the other end of the rope, were unable to draw the performer out of his place. His hands at G seemed to pull against the men, but they were of no advantage to him whatever.

Fig. 53.

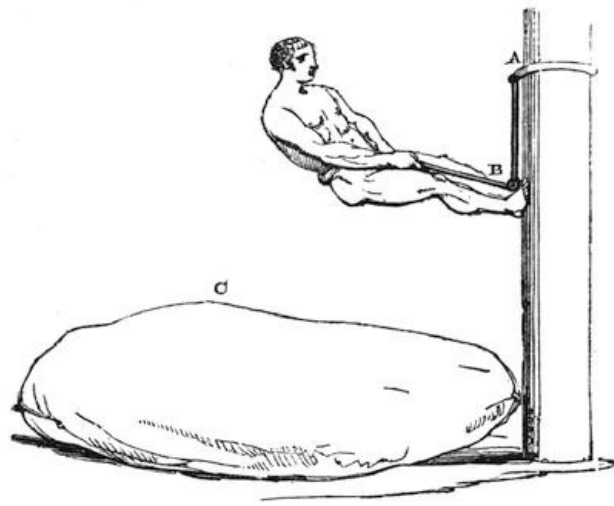

2. Another of the German's feats is shown in Fig. 53. Having fixed the rope above-mentioned to a strong post at A, and made it pass through a fixed iron eye at B, to the ring in his girdle, he planted his feet against the post at B, and raised himself from the ground by the rope, as shown in the figure. He then suddenly stretched out his legs, and broke the rope, falling back on a feather-bed at C, spread out to receive him.

3. In imitation of Firmus, he laid himself down on the ground, as shown in Fig. 54, and when an anvil A was placed upon his breast, a man hammered with all his force the piece of iron B, with a sledge hammer; and sometimes two smiths cut in two with chisels a great cold bar of iron laid upon the anvil. At other times a stone of huge dimensions, half of which is shown at C, was laid upon his belly, and broken with a blow of the great hammer.

Fig. 54.



4. The performer then placed his shoulders upon one chair and his heels upon another, as in Fig. 55, forming, with his backbone, thighs, and legs, an arch springing from its abutments at A and B. One or two men then stood upon his belly, rising up and down while the performer breathed. A stone, one and a half feet long, one foot broad, and half a foot thick, was then laid upon his belly, and broken by a sledge-hammer; an operation which may be performed with much less danger than when his back touched the ground, as in Fig. 54.

Fig. 55.

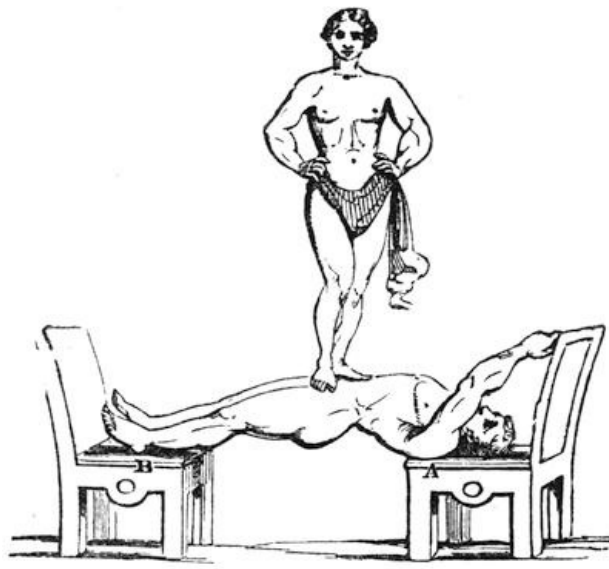

5. His next feat was to lie down on the ground, as in Fig. 56; a man being then placed on his knees, he draws his heels towards his body, and, raising his knees, he lifts up the man gradually, till having brought his knees perpendicularly under him, as in Fig. 57, he raises his own body up, and placing his arms round the man's legs, he rises with him, and sets him down on some low table or eminence of the same height as his knees. This feat he sometimes performed with two men in place of one.

Fig. 56.

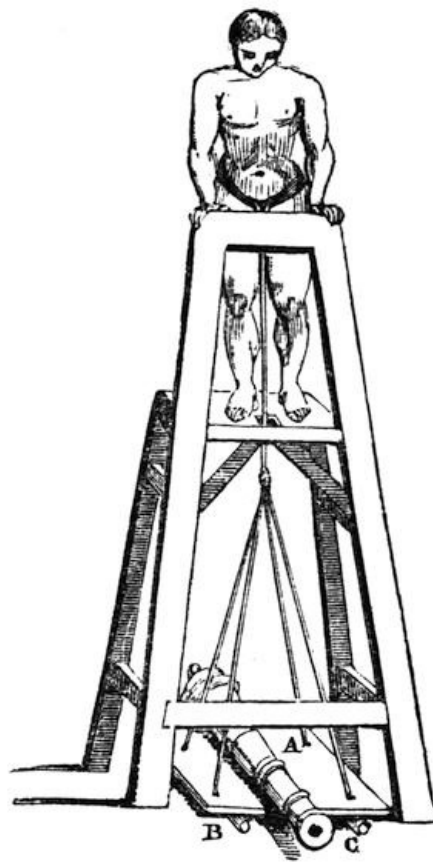

Fig. 57.



6. The last and apparently the most wonderful performance of the German is shown in Fig. 58, where he appears to raise a cannon A placed upon a scale, the four ropes of the scale being fixed to a rope or chain attached to his girdle in the manner already described. Previous to the fixing of the ropes, the cannon and scale rest upon two rollers B, C; but when all is ready, the two rollers are knocked from beneath the scale, and the cannon is sustained by the strength of his loins.

Fig. 58.



The German also exhibited his strength in twisting into a screw a flat piece of iron like A, Fig. 59. He first bent the iron into a right angle as at B, and then wrapping his handkerchief about its broad upper end, he held that end in his left hand, and with his right applied to the other end, twisted about the angular point, as shown at C. Lord Tullibardine succeeded in doing the same thing, and even untwisted one of the irons which the German had twisted.

Fig. 59.

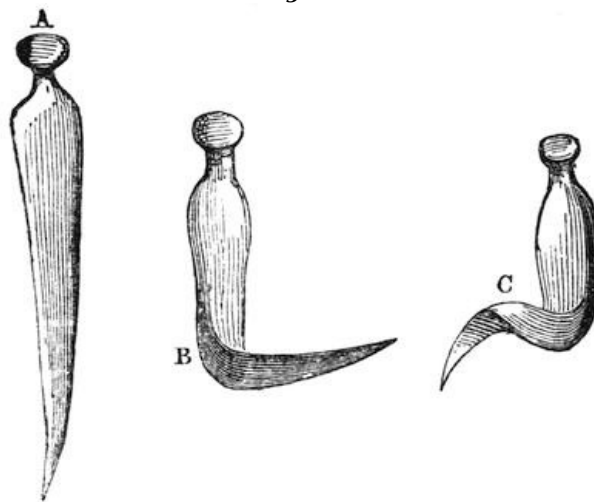

It would lead into details by no means popular were I to give a minute explanation of the mechanical principles upon which these feats depend. A few general observations will perhaps be sufficient for ordinary readers. The feats Nos. 1, 2, and 6, depend entirely on the natural strength of the bones of the pelvis, which form a double arch, which it would require an immense force to break, by any external pressure directed to the centre of the arch; and as the legs and thighs are capable of sustaining four or five thousand pounds when they stand quite upright, the performer has no difficulty in resisting the force of two horses, or of sustaining the weight of a cannon weighing two or three thousand pounds.

The feat of the anvil is certainly a very surprising one. The difficulty, however, really consists in sustaining the anvil, for when this is done, the effect of the hammering is nothing. If the anvil were a thin piece of iron, or even two or three times heavier than the hammer, the performer would be killed by a few blows; but the blows are scarcely felt when the anvil is very heavy, for the more matter the anvil has, the greater is its inertia, and it is the less liable to be struck out of its place; for when it has received by the blow the whole momentum of the hammer, its velocity will be so much less than that of the hammer, as its quantity of matter is greater. When the blow, indeed, is struck, the man feels less of the weight of the anvil than he did before, because in the reaction of the stone all the parts of it round about the hammer rise towards the blow. This property is illustrated by the well-known experiment of laying a stick with its ends upon two

drinking-glasses full of water, and striking the stick downwards in the middle with an iron bar. The stick will in this case be broken without breaking the glasses or spilling the water. But if the stick is struck upwards, as if to throw it up in the air, the glasses will break if the blow be strong, and if the blow is not very quick, the water will be spilt without breaking the glasses.

When the performer supports a man upon his belly as in Fig. 55, he does it by means of the strong arch formed by his backbone, and the bones of his legs and thighs. If there were room for them, he could bear three or four, or, in their stead, a great stone to be broken with one blow.

A number of feats of real and extraordinary strength were exhibited, about a century ago, in London, by Thomas Topham, who was five feet ten inches high, and about thirty-one years of age. He was entirely ignorant of any of the methods for making his strength appear more surprising, and he often performed by his own natural powers what he learned had been done by others by artificial means. A distressing example of this occurred in his attempt to imitate the feat of the German Samson, by pulling against horses. Ignorant of the method which we have already described, he seated himself on the ground with his feet against two stirrups, and by the weight of his body he succeeded in pulling against a single horse; but in attempting to pull against two horses, he was lifted out of his place, and one of his knees was shattered against the stirrups, so as to deprive him of most of the strength of one of his legs. The following are the feats of real strength which Dr. Desaguliers saw him perform:—

1. Having rubbed his fingers with coal-ashes to keep them from slipping, he rolled up a very strong and large pewter plate.
2. Having laid seven or eight short and strong pieces of tobacco-pipe on the first and third finger, he broke them by the force of his middle finger.
3. He broke the bowl of a strong tobacco-pipe placed between his first and third finger, by pressing his fingers together sideways.
4. Having thrust such another bowl under his garter, his legs being bent, he broke it to pieces by the tendons of his hams without altering the bending of his leg.
5. He lifted with his teeth, and held in a horizontal position for a considerable time, a table six feet long, with half a hundred weight hanging at the end of it. The feet of the table rested against his knees.
6. Holding in his right hand an iron kitchen poker three feet long and three inches round, he struck upon his bare left arm, between the elbow and the wrist, till he bent the poker nearly to a right angle.
7. Taking a similar poker and holding the ends of it in his hands, and the middle against the back of his neck, he brought both ends of it together before him, and he then pulled it almost straight again. This last feat was the most difficult, because the muscles which separate the arms horizontally from each other are not so strong as those which bring them together.
8. He broke a rope about two inches in circumference, which was partly wound about a cylinder four inches in diameter, having fastened the other end of it to straps that went over his shoulder.
9. Dr. Desaguliers saw him lift a rolling-stone of about 800lb. weight with his hands only, standing in a frame above it, and taking hold of a frame fastened to it. Hence Dr. Desaguliers gives the following relative view of the strengths of individuals:—

Strength of the weakest men	125lbs.
Strength of very strong men	400
Strength of Topham	800

The weight of Topham was about 200.

One of the most remarkable and inexplicable experiments relative to the strength of the human frame, which you have yourself seen and admired, is that in which a heavy man is raised with the greatest facility, when he is lifted up the instant that his own lungs and those of the persons who raise him are inflated with air. This experiment was, I believe, first shown in England a few years ago by Major H. who saw it performed in a large party at Venice, under the direction of an officer of the American Navy. As Major H. performed it more than once in my presence, I shall describe as nearly as possible the method which he prescribed. The heaviest person in the party lies down upon two chairs, his legs being supported by the one and his back by the other. Four persons, one at each leg and one at each shoulder, then try to raise him, and they find his dead weight to be very great, from the difficulty they experience in supporting him. When he is replaced in the chair, each of the four persons takes hold of the body as before, and the person to be lifted gives two signals by clapping his hands. At the first signal he himself and the four lifters begin to draw a long and full breath, and when the inhalation is completed, or the lungs filled, the second signal is given for raising the person from the chair. To his own surprise and that of his bearers, he rises with the greatest facility, as if he were no heavier than a feather. On several occasions I have observed that when one of the bearers performs his part ill, by making the inhalation out of time, the part of the body which he tries to raise is left as it were behind. As you have repeatedly seen this experiment, and have performed the part both of the load and of the bearer, you can testify how remarkable the effects appear to all parties, and how complete is the conviction, either that the load has been lightened, or the bearer strengthened by the prescribed process.

At Venice, the experiment was performed in a much more imposing manner. The heaviest man in the party was raised and sustained upon the points of the fore-fingers of six persons. Major H. declared that the experiment would not succeed if the person lifted were placed upon a board, and the strength of the individuals applied to the board. He conceived it necessary that the bearers should communicate directly with the body to be raised. I have not had an opportunity of making any experiments relative to these curious facts; but whether the general effect is an illusion, or the result of known or of new principles, the subject merits a careful investigation.

Among the remarkable exhibitions of mechanical strength and dexterity, we may enumerate that of supporting pyramids of men. This exhibition is a very ancient one. It is described, though not very clearly, by the Roman poet Claudian, and it has derived some importance in modern times, in consequence of its having been performed in various parts of Great Britain by the celebrated traveller Belzoni, before he entered upon the more estimable career of an explorer of Egyptian antiquities. The simplest form of this feat consists in placing a number of men on each other's shoulders, so that each row consists of a man fewer till they form a pyramid terminating in a single person, upon whose head a boy is sometimes placed with his feet upwards.

Among the displays of mechanical dexterity, though not grounded on any scientific principle, may be mentioned the art of walking along the ceiling of an apartment with the head downwards. This exhibition, which we have witnessed in one of the London Theatres, never failed to excite the wonder of the audience, although the movements of the inverted performer were not such as to inspire us with any high ideas of the mechanism by which they were effected. The following was probably the method by which the performer was carried along the ceiling. Two parallel grooves or openings were made in the ceiling at the same distance as the foot-tracks of a person walking on sand. These grooves were narrower than the human foot, so as to permit a rope, or chain, or strong wire, attached to the feet of the performer, to pass through the ceiling, where they were held by two or more persons above it. In this way the inverted performer might be carried along by a sliding or shuffling motion, similar to that which is adopted in walking in the dark, and in which the feet are lifted from the ground. A more regular motion, however, might be produced by a contrivance for attaching the rope or chain to the sole of the foot, at each step, and subsequently detaching it. In this way, when the performer is pulled against the ceiling by his left foot, he would lift his right foot, and having made a step with it, and planted it against the grooves, the rope would be attached to it, and when the rope was detached from the left foot, it would make a similar step, while the right foot was pulled against the ceiling. These effects might be facilitated and rendered more natural, by attaching to the body or to the feet of the performer strong wires invisible to the audience, and by using friction-wheels, if a sliding motion only is required.

Fig. 60.



A more scientific method of walking upon the ceiling is suggested by those beautiful pneumatic contrivances by which insects, fishes, and even some lizards are enabled to support the weight of their bodies against the force of gravity. The house-fly is well known to have the power of walking in an inverted position upon the ceilings of rooms, as well as upon the smoothest surfaces. In this case the fly does not rest upon its legs, and must therefore adhere to the ceiling, either by some glutinous matter upon its feet, or by the aid of some apparatus given it for that purpose. In examining the foot of the fly with a powerful microscope, it is found to consist of two concavities, as shown in Figs. 60 and 61, the first of which is copied from a drawing by G. Adams, published in 1746, and the second by J. C. Keller, a painter at Nuremberg, who drew it for a work published in 1766. The author of this work maintains that these concavities are only used when the fly moves horizontally, and that, when it moves perpendicularly or on the ceiling, they are turned up out of the way, and the progressive motion is effected by fixing the claws shown in the figure into the irregularities of the surface upon which the fly moves, whether it is glass, porcelain, or any other substance. Sir Everard Home, however, supposes, with great reason, that these concave surfaces are (like the leathern suckers used by children for lifting stones) employed to form a vacuum, so that the foot adheres, as it were, by suction to the ceiling, and enables the insect to support itself in an inverted position.

Fig. 61.



This conclusion Sir Everard has been led to draw from an examination of the foot of the *Lacerta* Gecko. Sir Joseph Banks had mentioned to him in the year 1815, that this lizard, which is a native of the island of Java, comes out in the evening from the roofs of the houses, and walks down the smooth hard-polished chunam walls in search of the flies which settle upon them, and which are its natural food. When Sir Joseph was at Batavia, he amused himself in catching this lizard. He stood close to the wall at some distance from the animal, and by suddenly scraping the wall with a long flattened pole, he was able to bring the animal to the ground.

Having procured from Sir Joseph a very large specimen of the Gecko, which weighed $5\frac{3}{4}$ ounces avoirdupois, Sir Everard Home was enabled to ascertain the peculiar mechanism by which the feet of this animal have the power of keeping hold of a smooth hard perpendicular wall, and carry up so heavy a weight as that of its body.

Fig. 62.

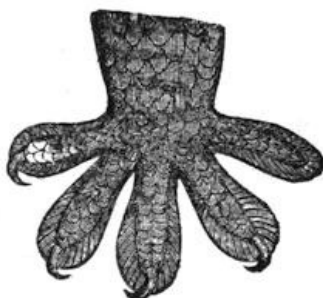
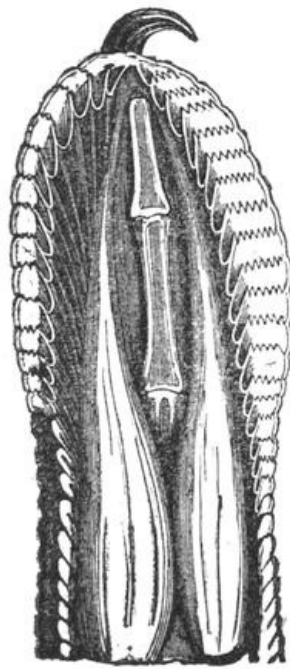

Fig. 63.



The foot of the Gecko has five toes (as shown in Fig. 62), and at the end of each of them, except the thumb, is a very sharp and highly-curved claw. On the under surface of each toe are sixteen transverse slits, leading to as many cavities or pockets, the depth of which is nearly equal to the length of the slit that forms the surface.

Fig. 64.



This structure is shown in Figs. 63 and 64, the former representing the under surface of one of the toes of the natural size, and the latter a toe dissected and highly magnified, to show the appearance of the cavities in its under surface, their fringed edge, the depth of the cavities, and the small muscles by which they are drawn open. The edge of the pockets or cavities is composed of rows of a beautiful fringe which are applied to the surface on which the animal walks against gravity, while the pockets themselves are pulled up by the muscles attached to them, so as to form the cavities into suckers.

This structure Sir Everard Home found to bear a considerable resemblance to that portion of the head of the *Echineis Remora*, or sucking-fish, by which it attaches itself to the shark, or the bottoms of ships. This apparatus is shown in Fig. 65: it is an oval form, and is surrounded by a broad loose moveable edge, capable of applying itself closely to the surface on which it is set. It consists of two rows of cartilaginous plates connected by one edge to the surface on which they are placed, the other, on the external edge, being serrated like that in the cavities of the feet of the Gecko. The two rows are separated by a thin ligamentous partition, and the plates, being raised or depressed by the voluntary muscles, form so many vacua, by means of which the adhesion of the fish is effected.

Fig. 65.

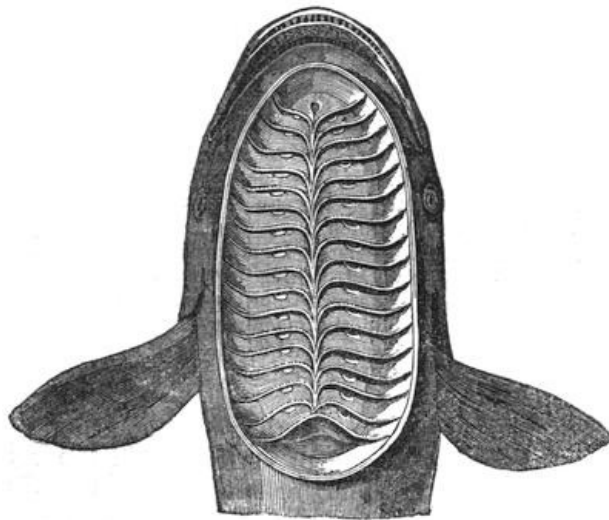

These beautiful contrivances of Divine Wisdom cannot fail to arrest the attention and excite the admiration of the reader; but though there can be little doubt that they are pneumatic suckers wrought by the voluntary muscles of the animals to which they belong, yet we would recommend the further examination of them to the attention of those who have good microscopes at their command.

LETTER XI.

Mechanical automata of the ancients—Moving tripods—Automata of Dædalus—Wooden pigeon of Archytas—Automatic clock of Charlemagne—Automata made by Turrianus for Charles V.—Camus's automatic carriage made for Louis XIV.—Degenne's mechanical peacock—Vaucanson's duck which ate and digested its food—Du Moulin's automata—Baron Kempelen's automaton chess-player—Drawing and writing automata—Maillardet's conjurer—Benefits derived from the passion for automata—Examples of wonderful machinery for useful purposes—Duncan's tambouring machinery—Watt's statue-turning machinery—Babbage's calculating machinery.

We have already seen that the ancients had attained some degree of perfection in the construction of automata, or pieces of mechanism which imitated the movements of man and the lower animals. The tripods, which Homer³¹ mentions as having been constructed by Vulcan for the banqueting-hall of the gods, advanced of their own accord to the table, and again returned to their place. Self-moving tripods are mentioned by Aristotle; and Philostratus informs us, in his life of Apollonius, that this philosopher saw and admired similar pieces of mechanism among the sages of India.

Dædalus enjoys also the reputation of having constructed machines that imitated the motions of the human body. Some of his statues are said to have moved about spontaneously; and Plato, Aristotle, and others have related that it was necessary to tie them, in order to prevent them from running away. Aristotle speaks of a wooden Venus, which moved about in consequence of quicksilver being poured into its interior; but Callistratus, the tutor of Demosthenes, states, with some probability, that the statues of Dædalus received their motion from the mechanical powers. Beckmann is of opinion that the statues of Dædalus differed only from those of the early Greeks and Egyptians in having their eyes open and their feet and hands free, and that the reclining posture of some, and the attitude of others, "as if ready to walk," gave rise to the exaggeration that they possessed the power of locomotion. This opinion, however, cannot be maintained with any show of reason; for if we apply such a principle in one case, we must apply it in all, and the mind would be left in a state of utter scepticism respecting the inventions of ancient times.

We are informed by Aulus Gellius, on the authority of Favorinus, that Archytas of Tarentum, who flourished about four hundred years before Christ, constructed a wooden pigeon that was capable of flying. Favorinus relates that, when it had once alighted, it could not again resume its flight; and Aulus Gellius adds, that it was suspended by balancing, and animated by a concealed aura, or spirit.

Among the earliest pieces of modern mechanism was the curious water-clock presented to Charlemagne by the Kaliph Haroun al Raschid. In the dial-plate there were twelve small windows corresponding with the divisions of the hours. The hours were indicated by the opening of the windows, which let out little metallic balls, which struck the hour by falling upon a brazen bell. The doors continued open till twelve o'clock, when twelve little knights, mounted on horseback, came out at the same instant, and after parading round the dial, shut all the windows and returned to their apartments.³²

The next automata of which any distinct account has been preserved are those of the celebrated John Muller, Regiomontanus, which have been mentioned by Kircher, Baptista Porta, Gassendi, Lana, and Bishop Wilkins. This philosopher is said to have constructed an artificial eagle, which flew to meet the Emperor Maximilian when he arrived at Nuremberg on the 7th June, 1740. After soaring aloft in the air, the eagle is stated to have met the Emperor at some distance from the city, and to have returned and perched upon the town gate, where it waited his approach. When the Emperor reached the gate, the eagle stretched out its wings, and saluted him by an inclination of its body. Muller is likewise reported to have constructed an iron fly which was put in motion by wheel-work, and which flew about and leapt upon the table. At an entertainment given by this philosopher to some of his familiar friends, the fly flew from his hand, and after performing a considerable round, it returned again to the hand of its master.

The Emperor Charles V., after his abdication of the throne, amused himself in his later years with automata of various kinds. The artist whom he employed was Janellus Turrianus of Cremona. It was his custom after dinner to introduce upon the table figures of armed men and horses. Some of these beat drums, others played upon flutes, while a third set attacked each other with spears. Sometimes he let fly wooden sparrows, which flew back again to their nest. He also exhibited corn-mills so extremely small that they could be concealed in a glove, yet so powerful that they could grind in a day as much corn as would supply eight men with food for a day.

The next piece of mechanism of sufficient interest to merit our attention is that which was made by M. Camus, for the amusement of Louis XIV. when a child. It consisted of a small coach, which was drawn by two horses, and which contained the figure of a lady within, with a footman and page behind. When this machine was placed at the extremity of a table of the proper size, the coachman smacked his whip, and the horses instantly set off, moving their legs in a natural manner, and drawing the coach after them: when the coach reached the opposite edge of the table, it turned sharply at a right angle, and proceeded along the adjacent edge. As soon as it arrived opposite the place where the king sat, it stopped; the page descended and opened the coach-door; the lady alighted, and with a curtsy presented a petition, which she held in her hand to the king. After waiting some time she again curtsied and re-entered the carriage. The page closed the door, and having resumed his place behind, the coachman whipped his horses and drove on. The footman, who had previously alighted, ran after the carriage and jumped up behind into his former place.

Not content with imitating the movements of animals, the mechanical genius of the 17th and 18th centuries ventured to perform by wheels and pinions the functions of vitality. We are informed by M. Lobat, that Gen. Degennes, a French officer who defended the colony of St. Christopher's against the English forces, constructed a peacock which could walk about as if alive, pick up grains of corn from the ground, digest them as if they had been submitted to the action of the stomach, and afterwards discharged them in an altered form. Degennes is said to have invented various machines of great use in navigation and gunnery, and to have constructed clocks without weights or springs.

The automaton of Degennes probably suggested to M. Vaucanson the idea of constructing his celebrated duck, which excited so much interest throughout Europe, and which was perhaps the most wonderful piece of mechanism that was ever made. Vaucanson's duck exactly resembled the living animal in size and appearance. It executed accurately all its movements and gestures, it ate and drank with avidity, performed all the quick motions of the head and throat which are peculiar to the living animal, and, like it, it muddled the water which it drank with its bill. It produced also the sound of quacking in the most natural manner. In the anatomical structure of the duck, the artist exhibited the highest skill. Every bone in the real duck had its representative in the automaton, and its wings were anatomically exact. Every cavity, apophysis, and curvature was imitated, and each bone executed its proper movements. When corn was thrown down before it, the duck stretched out its neck to pick it up, it swallowed it, digested it, and discharged it in a digested condition. The process of digestion was effected by chemical solution, and not by trituration, and the food digested in the stomach was conveyed away by tubes to the place of its discharge.

The automata of Vaucanson were imitated by one Du Moulin, a silversmith, who travelled with them through Germany in 1752, and who died at Moscow in 1765. Beckmann informs us that he saw several of them after the machinery had been deranged; but that the artificial duck, which he regarded as the most ingenious, was still able to eat, drink, and move. Its ribs, which were made of wire, were covered with duck's feathers, and the motion was communicated through the feet of the duck by means of a cylinder and fine chains like that of a watch.

Fig. 66.

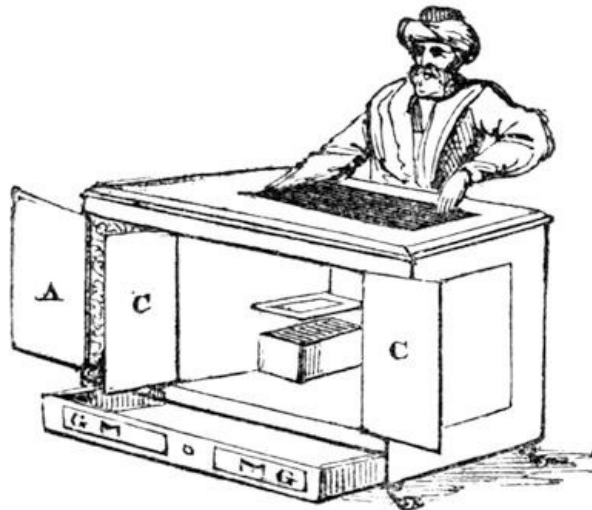

Fig. 67.



Ingenious as all these machines are, they sink into insignificance when compared with the automaton chess-player, which for a long time astonished and delighted the whole of Europe. In

the year 1769, M. Kempelen, a gentleman of Presburg in Hungary, constructed an automaton chess-player, the general appearance of which is shown in the annexed figures. The chess-player is a figure as large as life, clothed in a Turkish dress, sitting behind a large square chest or box, three feet and a half long, two feet deep, and two and a half high. The machine runs on castors, and is either seen on the floor when the doors of the apartment are thrown open, or is wheeled into the room previously to the commencement of the exhibition. The Turkish chess-player sits on a chair fixed to the square chest: his right arm rests on the table, and in the left he holds a pipe, which is removed during the game, as it is with this hand that he makes the moves. A chess-board, eighteen inches square, and bearing the usual number of pieces, is placed before the figure. The exhibitor then announces to the spectators his intention of showing them the mechanism of the automaton. For this purpose he unlocks the door A, Fig. 66, and exposes to view a small cupboard lined with black or dark-coloured cloth, and containing cylinders, levers, wheels, pinions, and different pieces of machinery, which *have the appearance* of occupying the whole space. He next opens the door B, Fig. 67, at the back of the same cupboard, and holding a lighted candle at the opening, he still further displays the inclosed machinery to the spectators, placed in front of A, Fig. 66. When the candle is withdrawn, the door B is then locked; and the exhibitor proceeds to open the drawer G G, Fig. 66, in front of the chest. Out of this drawer he takes a small box of counters, a set of chess-men, and a cushion for the support of the automaton's arm, as if this was the sole object of the drawer. The two front doors C C, of the large cupboard, Fig. 66, are then opened, and at the back-door D of the same cupboard, Fig. 67, the exhibitor applies a lighted candle, as before, for the purpose of showing its interior, which is lined with dark cloth like the other, and contains only a few pieces of machinery. The chest is now wheeled round, as in Fig. 67: the garments of the figure are lifted up, and the door E in the trunk, and another door F in the thigh, are opened, the doors B and D having been previously closed. When this exhibition of the interior of the machine is over, the chest is wheeled back into its original position on the floor. The doors A, C, C, in front, and the drawer G, G, are closed and locked, and the exhibitor, after occupying himself for some time at the back of the chest, as if he were adjusting the mechanism, removes the pipe from the hand of the figure, and winds up the machinery.

The automaton is now ready to play, and when an opponent has been found among the company, the figure takes the first move. At every move made by the automaton, the wheels of the machine are heard in action; the figure moves its head, and seems to look over every part of the chess-board. When it gives check to its opponent, it shakes its head *thrice*, and only *twice* when it checks the queen. It likewise shakes its head when a false move is made, replaces the adversary's piece on the square from which it was taken, and takes the next move itself. In general, though not always, the automaton wins the game.

During the progress of the game, the exhibitor often stands near the machine, and winds it up like a clock, after it has made ten or twelve moves. At other times he went to a corner of the room, as if it were to consult a small square box, which stood open for this purpose.

The chess-playing machine, as thus described, was exhibited after its completion in Presburg, Vienna, and Paris, to thousands, and in 1783 and 1784 it was exhibited in London and different parts of England, without the secret of its movements having been discovered. Its ingenious inventor, who was a gentleman and a man of education, never pretended that the automaton itself really played the game. On the contrary, he distinctly stated, "that the machine was a *bagatelle*, which was not without merit in point of mechanism, but that the effects of it appeared so marvellous only from the boldness of the conception, and the fortunate choice of the methods adopted for promoting the illusion."

Upon considering the operations of this automaton, it must have been obvious that the game of chess was performed either by a person enclosed in the chest, or by the exhibitor himself. The first of these hypotheses was ingeniously excluded by the display of the interior of the machine, for as every part contained more or less machinery, the spectator invariably concluded that the smallest dwarf could not be accommodated within, and this idea was strengthened by the circumstance, that no person of this description could be discovered in the suite of the exhibitor. Hence the conclusion was drawn, that the exhibitor actuated the machine either by mechanical means conveyed through its feet, or by a magnet concealed in the body of the exhibitor. That mechanical communication was not formed between the exhibitor and the figure, was obvious from the fact, that no such communication was visible, and that it was not necessary to place the machine on any particular part of the floor. Hence the opinion became very prevalent that the agent was a magnet; but even this supposition was excluded, for the exhibitor allowed a strong and well-armed loadstone to be placed upon the machine during the progress of the game. Had the moving power been a magnet, the whole action of the machine would have been deranged by the approximation of a loadstone concealed in the pockets of any of the spectators.

As Baron Kempelen himself had admitted that there was an illusion connected with the performance of the automaton, various persons resumed the original conjecture, that it was actuated by a person concealed in its interior, who either played the game of chess himself, or performed the moves which the exhibitor indicated by signals. A Mr. J. F. Freyhere, of Dresden, published a book on the subject in 1789, in which he endeavoured to explain, by coloured plates, how the effect was produced; and he concluded, "that a well-taught boy very thin and tall of his age (sufficiently so that he could be concealed in a drawer almost immediately under the chess-board), agitated the whole."

In another pamphlet, which had been previously published at Paris in 1785, the author not only

supposed that the machine was put in motion by a dwarf, a famous chess-player; but he goes so far as to explain the manner in which he could be accommodated within the machine. The invisibility of the dwarf when the doors were opened was explained by his legs and thighs being concealed in two hollow cylinders, while the rest of his body was out of the box, and hid by the petticoats of the automaton. When the doors were shut, the clacks produced by the swivel of a ratchet-wheel permitted the dwarf to change his place, and return to the box unheard; and while the machine is wheeled about the room, the dwarf had an opportunity of shutting the trap through which he passed into the machine. The interior of the figure was next shown, and the spectators were satisfied that the box contained no living agent.

Although these views were very plausible, yet they were never generally adopted; and when the automaton was exhibited in Great Britain in 1819 and 1820, by M. Maelzel, it excited as intense an interest as when it was first produced in Germany. There can be little doubt, however, that the secret has been discovered; and an anonymous writer has shown in a pamphlet, entitled "*An attempt to analyse the Automaton Chess-player of M. Kempelen,*" that it is capable of accommodating an ordinary sized man; and he has explained in the clearest manner how the inclosed player takes all the different positions, and performs all the motions which are necessary to produce the effects actually observed. The following is the substance of his observations:—The drawer G G when closed does not extend to the back of the chest, but leaves a space O, behind it (see Figs. 74, 75, and 76), fourteen inches broad, eight inches high, and three feet eleven inches long. This space is never exposed to the view of spectators. The small cupboard seen at A is divided into two parts, by a door or screen I, Fig. 73, which is moveable upon a hinge, and is so constructed that it closes at the same instant that B is closed. The whole of the front compartment as far as I is occupied with the machinery H. The other compartment behind I is empty, and communicates with the space O behind the drawer, the floor of this division being removed. The back of the great cupboard C C is double, and the part P Q, to which the quadrants are attached, moves on a joint Q, at the upper part, and forms when raised an opening S, between the two cupboards, by carrying with it part of the partition R, which consists of cloth tightly stretched. The false back is shown closed in Fig. 74, while Fig. 75 shows the same back raised, so as to form the opening S between the chambers.

When the spectator is allowed to look into the trunk of the figure by lifting up the dress, as in Fig. 75, it will be observed that a great part of the space is occupied by an inner trunk N, Figs. 75, 76, which passes off to the back in the form of an arch, and conceals from the spectators a portion of the interior. This inner trunk N opens and communicates with the chest by an aperture T, Fig. 77, about twelve inches broad and fifteen high. When the false back is raised, the two cupboards, the trunk N, and the space O behind the drawer, are all connected together.

No. 68.



No. 69.



The construction of the interior being thus understood, the chess-player may be introduced into the chest through the sliding panel U, Fig. 74. He will then raise the false back of the large cupboard, and assume the position represented by the shaded figure in Figs. 68 and 69. Things being in this state, the exhibitor is ready to begin his process of deception. He first opens the door A of the small cupboard, and from the crowded and very ingenious disposition of the machinery within it, the eye is unable to penetrate far beyond the opening, and the spectator concludes, without any hesitation, that the whole of the cupboard is filled, as it appears to be, with similar machinery. This false conclusion is greatly corroborated by observing the glimmering light which plays among the wheel-work when the door B is opened, and a candle held at the opening. This mode of exhibiting the interior of the cupboard satisfies the spectator also, that no opaque body, capable of holding or concealing any of the parts of a hidden agent, is interposed between the light and the observer. The door B is now locked and the screen I closed, and as this is done at the time that the light is withdrawn, it will wholly escape observation.

The door B is so constructed as to close by its own weight, but as the head of the chess-player will soon be placed very near it, the secret would be disclosed if, in turning round, the chest door should by any accident fly open. This accident is prevented by turning the key, and, lest this little circumstance should excite notice, it would probably be regarded as accidental, as the keys were immediately wanted for the other locks.

As soon as the door B is locked, and the screen I closed, the secret is no longer exposed to hazard, and the exhibitor proceeds to lead the minds of the spectators still farther from the real state of things. The door A is left open to confirm the opinion that no person is concealed within, and that nothing can take place in the interior without being observed.

Fig. 70.

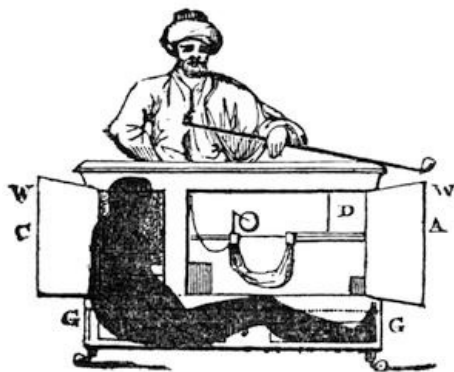

The drawer GG is now opened, apparently for the purpose of looking at the chess-men, cushion, and counters, which it contains; but the real object of it is to give time to the player to change his position, as shown in the annexed figure, and to replace the false back and partition preparatory to the opening of the great cupboard. The chess-player, as the figure shows, occupies with his body the back compartment of the small cupboard, while his legs and thighs are contained in the space O, behind the drawer GG, his body being concealed by the screen I, and his limbs by the drawer GG.

The great cupboard CC is now opened, and there is so little machinery in it, that the eye instantly discovers that no person is concealed in it. To make this more certain, however, a door is opened at the back, and a lighted candle held to it, to allow the spectators to explore every corner and recess.

The front doors of the great and small cupboard being left open, the chest is wheeled round to show the trunk of the figure, and the bunch of keys is allowed to remain in the door D, as the apparent carelessness of such a proceeding will help to remove any suspicion which may have been excited by the locking of the door B.

When the drapery of the figure has been raised, and the doors E and F in the trunk and thigh

opened, the chest is wheeled round again into its original position, and the doors E and F closed. In the mean time the player withdraws his legs from behind the drawer, as he cannot so easily do this when the drawer GG is pushed in.

In all these operations, the spectator flatters himself that he has seen in succession every part of the chest, while in reality some parts have been wholly concealed from his view, and others but imperfectly shown, while at the present time nearly half of the chest is excluded from view.

No. 71.



No. 72.



When the drawer G G is pushed in, and the doors A and C closed, the exhibitor adjusts the machinery at the back, in order to give time to the player to take the position shown in a front view in Fig. 71, and in profile in Fig. 72. In this position he will experience no difficulty in executing every movement made by the automaton. As his head is above the chess-board, he will see through the waistcoat of the figure, as easily as through a veil, the whole of the pieces on the board, and he can easily take up and put down a chess-man without any other mechanism than that of a string communicating with the finger of the figure. His right hand, being within the chest, may be employed to keep in motion the wheel-work for producing the noise which is heard during the moves, and to perform the other movements of the figure, such as that of moving the head, tapping on the chest, &c.

A very ingenious contrivance is adopted to facilitate the introduction of the player's left arm into the arm of the figure. To permit this, the arm of the figure requires to be drawn backwards; and for the purpose of concealing, and at the same time explaining this strained attitude, a pipe is ingeniously placed in the automaton's hand. For this reason the pipe is not removed till all the other arrangements are completed. When every thing has been thus prepared, the pipe is taken from the figure, and the exhibitor winds up, as it were, the inclosed machinery, for the double purpose of impressing upon the company the belief that the effect is produced by machinery, and of giving a signal to the player to put in motion the head of the automaton.

Fig. 73.

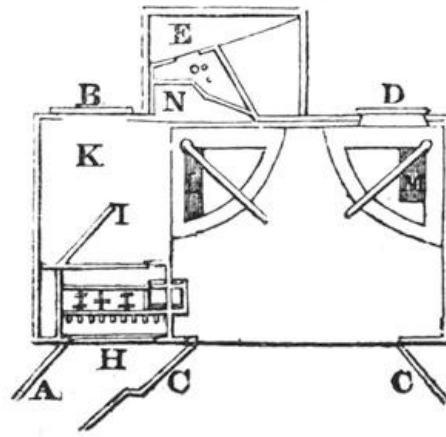
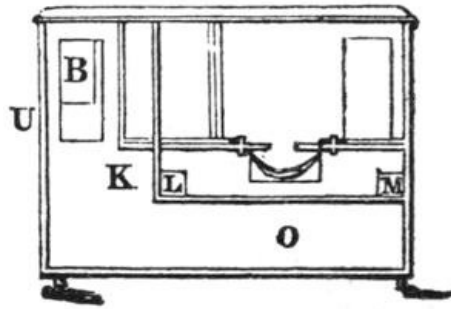

Fig. 74.



This ingenious explanation of the chess automaton is, our author states, greatly confirmed by the *regular and undeviating* mode of disclosing the interior of the chest; and he also shows that the facts which have been observed respecting the winding up of the machine, "afford positive proof that the axis turned by the key is quite free and unconnected either with a spring or weight, or any system of machinery."

In order to make the preceding description more intelligible, I shall add the following more detailed explanation of the figures.

Fig. 66 is a perspective view of the automaton seen in front with all the doors thrown open.

Fig. 67 is an elevation of the automaton, as seen from behind.

Fig. 68 is an elevation of the front of the chest, the shaded figure representing the inclosed player in his first position, or when the door A is opened.

Fig. 69 is a side elevation, the shaded figure representing the player in the same position.

Fig. 70 is a front elevation, the shaded figure showing the player in his second position, or that which he takes after the door B and screen I are closed, and the great cupboard opened.

Fig. 71 is a front elevation, the shaded figure showing the player in his third position, or that in which he plays the game.

Fig. 72 is a side elevation showing the figure in the same position.

Fig. 73 is a horizontal section of the chest through the line WW in Fig. 71.

Fig. 74 is a vertical section of the chest through the line XX in Fig. 73.

Fig. 75.

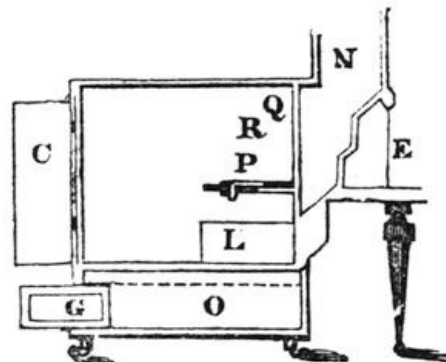

Fig. 76.

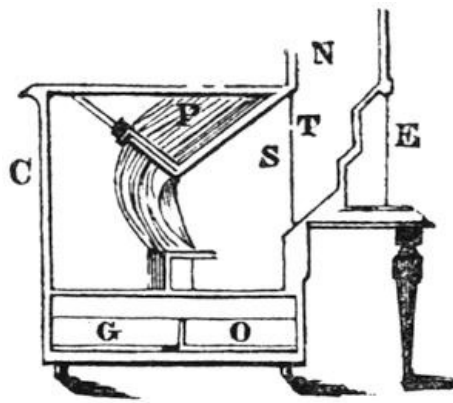

Fig. 75 is a vertical section through the line YY Fig. 71, showing the false back closed.

Fig. 76 is a similar vertical section showing the false back raised.

The following letters of reference are employed in all the figures:—

A. Front door of the small cupboard.

B. Back door of ditto.

C C. Front doors of large cupboard.

D. Back door of ditto.

E. Door of ditto.

F. Door of the thigh.

G G. The drawer.

H. Machinery in front of the small cupboard.

I. Screen behind the machinery.

K. Opening caused by the removal of part of the floor of the small cupboard.

L. A box which serves to conceal an opening in the floor of the large cupboard, made to facilitate the first position; and which also serves as a seat for the third position.

M. A similar box to receive the toes of the player in the first position.

N. The inner chest filling up part of the trunk.

O. The space behind the drawer.

P Q. The false back turning on a joint at Q.

R. Part of the partition formed of cloth stretched tight, which is carried up by the false back to form the opening between the chambers.

S. The opening between the chambers.

T. The opening connecting the trunk and chest, which is partly concealed by the false back.

U. Panel which is split aside to admit the player.

Various pieces of mechanism of wonderful ingenuity have been constructed for the purposes of drawing and writing. One of these, invented by M. Le Droz, the son of the celebrated Droz of Chaux le Fonds, has been described by Mr. Collinson. The figure was the size of life. It held in its hand a metallic style, and when a spring was touched, so as to release a detent, the figure immediately began to draw upon a card of Dutch vellum previously laid under its hand. After the drawing was executed on the first card, the figure rested. Other five cards were then put in, in succession, and upon these it delineated in the same manner different subjects. On the first card it drew "elegant portraits and likenesses of the king and queen facing each other;" and Mr. Collinson remarks, that it was curious to observe with what precision the figure lifted up its pencil in its transition from one point of the drawing to another, without making the slightest mistake.

M. Maillardet has executed an automaton which both writes and draws. The figure of a boy kneeling on one knee holds a pencil in his hand. When the figure begins to work, an attendant dips the pencil in ink, and adjusts the drawing-paper upon a brass tablet. Upon touching a spring, the figure proceeds to write, and when the line is finished, its hand returns to dot and stroke the letters when necessary. In this manner it executes four beautiful pieces of writing in French and English, and three landscapes, all of which occupy about one hour.

One of the most popular pieces of mechanism which we have seen is the magician constructed by

M. Maillardet for the purpose of answering certain given questions. A figure dressed like a magician appears seated at the bottom of a wall, holding a wand in one hand, and a book in the other. A number of questions ready prepared are inscribed on oval medallions, and the spectator takes any of these which he chooses, and to which he wishes an answer, and having placed it in a drawer ready to receive it, the drawer shuts with a spring till the answer is returned. The magician then rises from his seat, bows his head, describes circles with his wand, and, consulting the book as if in deep thought, he lifts it towards his face. Having thus appeared to ponder over the proposed question, he raises his wand, and striking with it the wall above his head, two folding-doors fly open, and display an appropriate answer to the question. The doors again close, the magician resumes his original position, and the drawer opens to return the medallion. There are twenty of these medallions, all containing different questions, to which the magician returns the most suitable and striking answers. The medallions are thin plates of brass of an elliptical form, exactly resembling each other. Some of the medallions have a question inscribed on each side, both of which the magician answers in succession. If the drawer is shut without a medallion being put into it, or if a *blank* medallion, viz., one which contains no question, is put into the drawer, the magician rises, consults his book, shakes his head, and resumes his seat. The folding-doors remain shut, and the drawer is returned empty. If two medallions are put into the drawer together, an answer is returned only to the lower one. When the machinery is wound up, the movements continue about an hour, during which time about fifty questions may be answered. The method by which the different medallions acted upon the machinery, so as to produce the proper answers to the questions which they bore, was of course kept a secret by the inventor, but it was discovered by Mr. Brockedon, who has kindly communicated to me an account of it.

Upon examining the edge of the circular medallions, Mr. Brockedon discovered in all of them, except the blanks, a small hole almost concealed by the milling. This led Mr. Brockedon to examine the receptacle for the medallion in the drawer, and he observed the edge of a pin flush with the edge of the receptacle, whence the pin was protruded by the machine into the holes in the medallion, the depth of the hole regulating the answer. In order to prove this, Mr. B. cut a slip from a cedar pencil small enough to enter easily the holes in the medallion, if he found them to be of different depths. As the blank medallions had no hole, and produced only a shake of the magician's head, Mr. B. took a medallion with a question, and having plugged the hole with a bit of cedar, he cut it flush, and having placed it in the receptacle, the conjuror shook his head, and thus bore testimony to the truth of Mr. Brockedon's discovery.

M. Maillardet has constructed various other automata, representing insects and other animals. One of these was a spider entirely made of steel, which exhibited all the movements of the animal. It ran on the surface of a table during three minutes, and to prevent it from running off, its course always tended towards the centre of the table. He constructed likewise a caterpillar, a lizard, a mouse, and a serpent. The serpent crawls about in every direction, opens its mouth, hisses, and darts out its tongue.

Ingenious and beautiful as all these pieces of mechanism are, and surprising as their effects appear even to scientific spectators, the principal object of their inventors was to astonish and amuse the public. We should form an erroneous judgment, however, if we suppose that this was the only result of the ingenuity which they displayed. The passion for automatic exhibitions, which characterized the 18th century, gave rise to the most ingenious mechanical devices, and introduced among the higher orders of artists habits of nice and accurate execution in the formation of the most delicate pieces of machinery. The same combination of the mechanical powers which made the spider crawl, or which waved the tiny rod of the magician, contributed in future years to purposes of higher import. Those wheels and pinions, which almost eluded our senses by their minuteness, re-appeared in the stupendous mechanism of our spinning-machines and our steam-engines. The elements of the tumbling-puppet were revived in the chronometer, which now conducts our navy through the ocean; and the shapeless wheel which directed the hand of the drawing automaton has served, in the present age, to guide the movements of the tambouring engine. Those mechanical wonders, which in one century enriched only the conjuror who used them, contributed in another to augment the wealth of the nation; and those automatic toys, which once amused the vulgar, are now employed in extending the power and promoting the civilization of our species. In whatever way, indeed, the power of genius may invent or combine, and to whatever low or even ludicrous purposes that invention or combination may be originally applied, society receives a gift which it can never lose; and though the value of the seed may not be at once recognized, and though it may lie long unproductive in the ungenial till of human knowledge, it will some time or other evolve its germ, and yield to mankind its natural and abundant harvest.

Did the limits of so popular a volume as this ought to be permit it, I should have proceeded to give a general description of some of these extraordinary pieces of machinery, the construction and effects of which never fail to strike the spectator with surprise. This, however, would lead me into a field too extensive, and I shall therefore confine myself to a notice of three very remarkable pieces of mechanism which are at present very little known to the general reader, viz., the tambouring machine of Mr. Duncan, the statue-turning machine of Mr. Watt, and the calculating machinery of Mr. Babbage.

The tambouring of muslins, or the art of producing upon them ornamental flowers and figures, has been long known and practised in Britain as well as in other countries; but it was not long before the year 1790, that it became an object of general manufacture in the west of Scotland, where it was chiefly carried on. At first it was under the direction of foreigners; but their aid was

not long necessary, and it speedily extended to such a degree as to occupy, either wholly or partially, more than 20,000 females. Many of these labourers lived in the neighbourhood of Glasgow, which was the chief seat of the manufacture; but others were scattered through every part of Scotland, and supplied by agents with work and money. In Glasgow, a tambourer of ordinary skill could not in general earn more than five or six shillings a week by constant application; but to a labouring artisan, who had several daughters, even these low wages formed a source of great wealth. At the age of five years, a child capable of handling a needle was devoted to tambouring, even though it could not earn more than a shilling or two in a week; and the consequence of this was, that female children were taken from school, and rendered totally unfit for any social or domestic duty. The tambouring population, was, therefore, of the worst kind, and it must have been regarded as a blessing rather than as a calamity, when the work which they performed was entrusted to regular machinery.

Mr. John Duncan of Glasgow, the inventor of the tambouring machinery, was one of those unfortunate individuals who benefit their species without benefiting themselves, and who died in the meridian of life, the victim of poverty and of national ingratitude. He conceived the idea of bringing into action a great number of needles at the same time, in order to shorten the process by manual labour; but he at first was perplexed about the diversification of the pattern. This difficulty, however, he soon surmounted by employing two forces at right angles to each other, which gave him a new force in the direction of the diagonal of the parallelogram, whose sides were formed by the original forces. His first machine was very imperfect; but after two years' study, he formed a company, at whose expense six improved machines were put in action, and who secured the invention by a patent. At this time the idea of rendering the machine automatic had scarcely occurred to him; but he afterwards succeeded in accomplishing this great object, and the tambouring machines were placed under the surveillance of a steam-engine. Another patent was taken for these improvements. The reader who desires to have a minute account of these improvements, and of the various parts of the machinery, will be amply gratified by perusing the inventor's own account of the machinery in the article CHAINWORK in the Edinburgh Encyclopædia. At present it will be sufficient to state, that the muslin to be tamboured was suspended vertically in a frame, which was capable of being moved both in a vertical and a horizontal direction. Sixty or more needles lying horizontally occupied a frame in front of the muslin web. Each of these working needles, as they are called, was attended by a feeding-needle, which, by a circular motion round the working-needle, lodged upon the stem of the latter the loop of the thread. The sixty needles then penetrated the web, and, in order that they might return again without injuring the fabric, the barb or eye of the needle, which resembled the barb of a fishing-hook, was shut by a slider. The muslin web then took a new position by means of the machinery that gave it its horizontal and vertical motion, so that the sixty needles penetrated it, at their next movement, at another point of the figure or flower. This operation went on till sixty flowers were completed. The web was then slightly wound up, that the needles might be opposite that part of it on which they were to work another row of flowers.

The flowers were generally at an inch distance, and the rows were placed so that the flowers formed what are called diamonds. There were seventy-two rows of flowers in a yard, so that in every square yard there were nearly 4000 flowers, and in every piece of ten yards long 40,000. The number of loops or stitches in a flower varied with the pattern, but on an average there were about thirty. Hence the number of stitches in a yard were 120,000, and the number in a piece is 1,200,000. The average work done in a week by one machine was fifteen yards, or 60,000 flowers, or 1,800,000 stitches; and by comparing this with the work done by one person with the hand, it appeared that the machine enabled one person to do the work of twenty-four persons.

One of the most curious and important applications of machinery to the arts which has been suggested in modern times, was made by the late Mr. Watt, in the construction of a machine for copying or reducing statues and sculpture of all kinds. The art of multiplying busts and statues, by casts in plaster of Paris, has been the means of diffusing a knowledge of this branch of the fine arts; but from the fragile nature of the material, the copies thus produced were unfit for exposure to the weather, and therefore ill calculated for ornamenting public buildings, or for perpetuating the memory of public achievements. A machine, therefore, which is capable of multiplying the labours of the sculptor in the durable materials of marble or of brass was a desideratum of the highest value, and one which could have been expected only from a genius of the first order. During many years Mr. Watt carried on his labours in secret, and he concealed even his intention of constructing such a machine. After he had made considerable progress in its execution, and had thought of securing his invention by a patent, he learned that an ingenious individual in his own neighbourhood had been long occupied in the same pursuit; and Mr. Watt informed me that he had every reason to believe that this gentleman was entirely ignorant of his labours. A proposal was then made that the two inventors should combine their talents, and secure the privilege by a joint patent; but Mr. Watt had experienced so frequently the fatal operation of our patent laws, that he saw many difficulties in the way of such an arrangement, and he was unwilling, at his advanced age, to embark in a project so extensive, and which seemed to require for its successful prosecution all the ardour and ambition of a youthful mind. The scheme was therefore abandoned; and such is the unfortunate operation of our patent laws, that the circumstance of two individuals having made the same invention has prevented both from bringing it to perfection, and conferring a great practical benefit upon their species. The machine which Mr. Watt had constructed had actually executed some excellent pieces of work. I have seen in his house at Heathfield copies of basso-relievos, and complete statues of a small size; and some of his friends have in their possession other specimens of its performance.

Of all the machines which have been constructed in modern times, the calculating-machine is doubtless the most extraordinary. Pieces of mechanism for performing particular arithmetical operations have been long ago constructed, but these bear no comparison either in ingenuity or in magnitude to the grand design conceived and nearly executed by Mr. Babbage. Great as the power of mechanism is known to be, yet we venture to say, that many of the most intelligent of our readers will scarcely admit it to be possible that astronomical and navigation tables can be accurately computed by machinery; that the machine can itself correct the errors which it may commit; and that the results of its calculations, when absolutely free from error, can be printed off, without the aid of human hands, or the operation of human intelligence. All this, however, Mr. Babbage's machine can do; and as I have had the advantage of seeing it actually calculate, and of studying its construction with Mr. Babbage himself, I am able to make the above statement on personal observation. The calculating machine now constructing under the superintendence of the inventor has been executed at the expense of the British Government, and is of course their property. It consists essentially of two parts; a calculating part, and a printing part, both of which are necessary to the fulfilment of Mr. Babbage's views; for the whole advantage would be lost if the computations made by the machine were copied by human hands and transferred to types by the common process. The greater part of the calculating machinery is already constructed, and exhibits workmanship of such extraordinary skill and beauty, that nothing approaching to it has been witnessed. In order to execute it, particularly those parts of the apparatus which are dissimilar to any used in ordinary mechanical constructions, tools and machinery of great expense and complexity have been invented and constructed; and in many instances contrivances of singular ingenuity have been resorted to which cannot fail to prove extensively useful in various branches of the mechanical arts.

The drawings of this machinery, which form a large part of the work, and on which all the contrivance has been bestowed, and all the alterations made, cover upwards of 400 *square feet of surface*, and are executed with extraordinary care and precision.

In so complex a piece of mechanism, in which interrupted motions are propagated simultaneously along a great variety of trains of mechanism, it might have been supposed that obstructions would arise, or even incompatibilities occur, from the impracticability of foreseeing all the possible combinations of the parts; but this doubt has been entirely removed, by the constant employment of a system of mechanical notation invented by Mr. Babbage, which places distinctly in view, at every instant, the progress of motion through all the parts of this or any other machine, and by writing down in tables the times required for all the movements, this method renders it easy to avoid all risk of two opposite actions arriving at the same instant at any part of the engine.

In the printing part of the machine less progress has been made in the actual execution than in the calculating part. The cause of this is the greater difficulty of its contrivance, not for transferring the computations from the calculating part to the copper or other plate destined to receive it, but for giving to the plate itself that number and variety of movements which the forms adopted in printed tables may call for in practice.

The practical object of the calculating engine is to compute and print a great variety and extent of astronomical and navigation tables, which could not be done without enormous intellectual and manual labour, and which, even if executed by such labour, could not be calculated with the requisite accuracy. Mathematicians, astronomers, and navigators, do not require to be informed of the real value of such tables; but it may be proper to state, for the information of others, that *seventeen* large folio volumes of logarithmic tables alone were calculated, at an enormous expense, by the French Government; and that the British Government regarded these tables to be of such national value, that they proposed to the French Board of Longitude to print an *abridgement* of them at the joint expense of the two nations, and offered to advance 5000*l.* for that purpose. Besides logarithmic tables, Mr. Babbage's machine will calculate tables of the powers and products of numbers, and all astronomical tables for determining the positions of the sun, moon, and planets; and the same mechanical principles have enabled him to integrate innumerable equations of finite differences, that is, when the equation of differences is given, he can, by setting an engine, produce at the end of a given time any distant term which may be required, or any succession of terms commencing at a distant point.

Besides the cheapness and celerity with which this machine will perform its work, the *absolute accuracy* of the printed results deserves especial notice. By peculiar contrivances, any small error produced by accidental dust, or by any slight inaccuracy in one of the wheels, is corrected as soon as it is transmitted to the next, and this is done in such a manner as effectually to prevent any accumulation of small errors from producing an erroneous figure in the result.

In order to convey some idea of this stupendous undertaking, we may mention the effects produced by a small trial engine constructed by the inventor, and by which he computed the following table from the formula $x^2 + x + 41$. The figures, as they were calculated by the machine, were not exhibited to the eye as in sliding-rules and similar instruments, but were actually presented to the eye on two opposite sites of the machine, the number 383, for example, appearing in figures before the person employed in copying.

Table calculated by a small Trial Engine.

41	131	383	797	1373
43	151	421	853	1447

47	173	461	911	1523
53	197	503	971	1601
61	223	547	1033	1681
71	251	593	1097	1763
83	281	641	1163	1847
97	313	691	1231	1933
113	347	743	1301	2021

While the machine was occupied in calculating this table, a friend of the inventor undertook to write down the numbers as they appeared. In consequence of the copyist writing quickly, he rather more than kept pace with the engine, but as soon as five figures appeared, the machine was at least equal in speed to the writer. At another trial *thirty-two* numbers of the same table were calculated in the space of *two minutes and thirty seconds*; and as these contained *eighty-two* figures, the engine produced thirty-three figures every minute, or more than one figure in every two seconds. On another occasion it produced *forty-four* figures per minute. This rate of computation could be maintained for any length of time; and it is probable that few writers are able to copy with equal speed for many hours together.

Some of that class of individuals who envy all great men, and deny all great inventions, have ignorantly stated that Mr. Babbage's invention is not new. The same persons, had it suited their purpose, would have maintained that the invention of spectacles was an anticipation of the telescope; but even this is more true than the allegation that the arithmetical machines of Pascal and others were the types of Mr. Babbage's engine. The object of these machines was entirely different. Their highest functions were to perform the operations of common arithmetic. Mr. Babbage's engine, it is true, can perform these operations also, and can extract the roots of numbers, and approximate to the roots of equations, and even to their impossible roots. But this is not its object. Its function, in contradistinction to that of all other contrivances for calculating, is to embody in machinery the method of differences, which has never before been done; and the effects which it is capable of producing, and the works which in the course of a few years we expect to see it execute, will place it at an infinite distance from all other efforts of mechanical genius.³³

LETTER XII.

Wonders of chemistry—Origin, progress, and objects of alchemy—Art of breathing fire—Employed by Barchochebas, Eunus, &c.—Modern method—Art of walking upon burning coals and red-hot iron, and of plunging the hands in melted lead and boiling water—Singular property of boiling tar—Workmen plunge their hands in melted copper—Trial of ordeal by fire—Aldini's incombustible dresses—Examples of their wonderful power in resisting flame—Power of breathing and enduring air of high temperatures—Experiments made by Sir Joseph Banks, Sir Charles Blagden, and Mr. Chantrey.

Chemistry has from its infancy been pre-eminently the science of wonders. In her laboratory the alchemist and the magician have revelled uncontrolled, and from her treasures was forged the sceptre which was so long and so fatally wielded over human reason. The changes which take place in the bodies immediately around us are too few in number and too remote from observation to excite much of our notice; but when the substances procured directly from nature, or formed casually by art, become objects of investigation, they exhibit in their simple or combined actions the most extraordinary effects. The phenomena which they display, and the products which they form, so little resemble those with which we are familiar, that the most phlegmatic and the least speculative observer must have anticipated from them the creation of new and valuable compounds. It can scarcely, therefore, be a matter of surprise that minds of the highest order, and spirits of the loftiest ambition, should have sought in the transmutations of chemistry for those splendid products which were conceived to be most conducive to human happiness.

The disciple of Mammon grew pale over his crucible in his ardour to convert the baser metals into gold; the philosopher pined in secret for the universal solvent which might develop the elements of the precious stones and yield to him the means of their production; and the philanthropist aspired after a universal medicine, which might arrest disease in its course, and prolong indefinitely the life of man. To us, who live under the meridian of knowledge, such expectations must appear as presumptuous as they were delusive; but when we consider that gold and silver were actually produced by chemical processes from the rude ores of lead and copper—that some of the most refractory bodies had yielded to the disintegrating and solvent powers of chemical agents, and that the mercurial preparations of the Arabian physicians had operated like charms in the cure of diseases that had resisted the feeble medicines of the times, we may find some apology for the extravagant expectations of the alchemists.

An object of lofty pursuit, even if it be one of impossible attainment, is not unworthy philosophical ambition. Though we cannot scale the summit of the volcanic cone, we may yet reach its heaving flanks; and though we cannot decompose its loftiest fires, we may yet study the lava which they have melted and the products which they have sublimed. In like manner, though the philosopher's stone has not been found, chemistry has derived rich accessions from its search;—though the general solvent has not been obtained, yet the diamond and the gems have surrendered to science their adamantine strength;—and though the elixir of life has never been distilled, yet other medicines have soothed the "ills which flesh is heir to," and prolonged in no slight degree the average term of our existence.

Thus far the pursuits of the alchemist were honourable and useful; but when his calling was followed, as it soon was, by men prodigal of fortune and of character, science became an instrument of crime; secrets unattained were bartered for the gold of the credulous and the ignorant, and books innumerable were composed to teach these pretended secrets to the world. An intellectual reaction, however, soon took place; and those very princes who had sought to fill their exhausted treasuries at the furnace of the chemist, were the first to enact laws against the frauds which they had encouraged, and to dispel the illusions which had so long deceived their subjects.

But even when the moral atmosphere of Europe was thus disinfected, chemistry supplied the magician with his most lucrative wonders, and those who could no longer delude the public with dreams of wealth and longevity, now sought to amuse and astonish them by the exhibition of their skill. The narrow limits of this volume will not permit me to give even a general view of those extraordinary effects which this popular science can display. I must therefore select from its inexhaustible stores those topics which are most striking in their results, and most popular in their details.

One of the most ancient feats of magic was the art of breathing flame,—an art which even now excites the astonishment of the vulgar. During the insurrection of the slaves in Sicily, in the second century before Christ, a Syrian named Eunus acquired by his knowledge the rank of their leader. In order to establish his influence over their minds, he pretended to possess miraculous power. When he wished to inspire his followers with courage, he breathed flames or sparks among them from his mouth, at the same time that he was rousing them by his eloquence. St. Jerome informs us that the Rabbi Barchochebas, who headed the Jews in their last revolt against Hadrian, made them believe that he was the Messiah, by vomiting flames from his mouth; and at a later period, the Emperor Constantius was thrown into a state of alarm when Valentinian informed him that he had seen one of the body-guards breathing out fire and flames. We are not acquainted with the exact methods by which these effects were produced; but Florus informs us that Eunus filled a perforated nut-shell with sulphur and fire, and having concealed it in his mouth, he breathed gently through it while he was speaking. This art is performed more simply by the modern juggler. Having rolled together some flax or hemp, so as to form a ball the size of a walnut, he sets it on fire, and allows it to burn till it is nearly consumed: he then rolls round it

while burning some additional flax, and by these means the fire may be retained in it for a considerable time. At the commencement of his exhibition he introduces the ball into his mouth, and while he breathes through it the fire is revived, and a number of burning sparks are projected from his mouth. These sparks are too feeble to do any harm, provided he inhales the air through his nostrils.

The kindred art of walking on burning coals or red-hot iron remounts to the same antiquity. The priestesses of Diana at Castabala in Cappadocia were accustomed, according to Strabo, to walk over burning coals; and at the annual festival which was held in the temple of Apollo on Mount Soracte in Etruria, the Hirpi marched over burning coals, and on this account they were exempted from military service, and received other privileges from the Roman Senate. This power of resisting fire was ascribed even by Varro to the use of some liniment with which they anointed the soles of their feet.

Of the same character was the art of holding red-hot iron in the hands or between the teeth, and of plunging the hands into boiling water or melted lead. About the close of the seventeenth century, an Englishman of the name of Richardson rendered himself famous by chewing burning coals, pouring melted lead upon his tongue, and swallowing melted glass. That these effects are produced partly by deception, and partly by a previous preparation of the parts subjected to the heat, can scarcely admit of a doubt. The fusible metal, composed of mercury, tin, and bismuth, which melts at a low temperature, might easily have been substituted in place of lead; and fluids of easy ebullition may have been used in place of boiling water. A solution of spermaceti or sulphuric ether, tinged with alkanet root, which becomes solid at 50° of Fahrenheit, and melts and boils with the heat of the hand, is supposed to be the substance which is used at Naples when the dried blood of St. Januarius melts spontaneously, and boils over the vessel which contains it.

But even when the fluid requires a high temperature to boil, it may have other properties, which enable us to plunge our hands into it with impunity. This is the case with boiling tar, which boils at a temperature of 220°, even higher than that of water. Mr. Davenport informs us, that he saw one of the workmen in the Royal Dock-yard at Chatham immerse his naked hand in tar of that temperature. He drew up his coat-sleeves, dipped in his hand and wrist, bringing out fluid tar, and pouring it off from his hand as from a ladle. The tar remained in complete contact with his skin, and he wiped it off with tow. Convinced that there was no deception in this experiment, Mr. Davenport immersed the entire length of his fore-finger in the boiling cauldron, and moved it about a short time before the heat became inconvenient. Mr. Davenport ascribes this singular effect to the slowness with which the tar communicates its heat, which he conceives to arise from the abundant volatile vapour which is evolved, "carrying off rapidly the caloric in a latent state, and intervening between the tar and the skin, so as to prevent the more rapid communication of heat." He conceives also, that when the hand is withdrawn, and the hot tar adhering to it, the rapidity with which this vapour is evolved from the surface exposed to the air cools it immediately. The workmen informed Mr. Davenport that, if a person put his hand into the cauldron with his glove on, he would be dreadfully burnt; but this extraordinary result was not put to the test of observation.

But though the conjurors with fire may have availed themselves of these singular properties of individual bodies, yet the general secret of their art consisted in rendering the skin of the exposed parts callous and insensible to heat,—an effect which may be produced by continually compressing or singeing them till the skin acquires a horny consistence. A proof of this opinion is mentioned by Beckmann, who assures us, that in September, 1765, when he visited the copper-works at Awestad, one of the workmen, bribed by a little money to drink, took some of the melted copper in his hand, and, after showing it to the company, threw it against a wall. He then squeezed the fingers of his horny hand close to each other, held it a few minutes under his armpit, to make it perspire, as he said, and taking it again out, drew it over a ladle filled with melted copper, some of which he skimmed off, and moved his hand backwards and forwards very quickly by way of ostentation. During this performance, M. Beckmann noticed a smell like that of singed horn or leather, though the hand of the workman was not burned. This callosity of the skin may be effected by frequently moistening it with dilute sulphuric acid. Some allege that the juices of certain plants produce the same effect, while others recommend the frequent rubbing of the skin with oil. The receipt given by Albertus Magnus for this purpose was of a different nature. It consisted of a non-conducting calcareous paste, which was made to adhere to the skin by the sap of the marsh-mallow, the slimy seeds of the flea-bane, and the white of an egg.

As the ancients were acquainted with the incombustibility of asbestos or amianthus, and the art of weaving it into cloth, it is highly probable that it was employed in the performance of some of their miracles, and it is equally probable that it was subsequently used, along with some of the processes already described, in enabling the victims of superstition to undergo without hazard the trial of ordeal by fire. In every country where this barbarous usage prevailed, whether in the sanctuary of the Christian idolater, or in the pagan temple of the Bramin, or under the wild orgies of the African savage, Providence seems to have provided the means of meeting it with impunity. In Catholic countries this exculpatory judgment was granted chiefly to persons in weak health, who were incapable of using arms, and particularly to monks and ecclesiastics, who could not avail themselves of the trial by single combat. The fire ordeal was conducted in the church under the inspection of the clergy: mass was at the same time celebrated, and the iron and the victims were consecrated by the sprinkling of holy water. The preparatory steps were also under the direction of the priests. It was necessary that the accused should be placed three days and

three nights under their care, both before and after the trial. Under the pretence of preventing the defendant from preparing his hands by art, and in order to ascertain the result of the ordeal, his hands were covered up and sealed during the three days which preceded and followed the fiery application; and it has been plausibly conjectured by Beckmann, that during the first three days the preventive was applied to those whom they wished to acquit, and that the last three days were requisite to bring back the hands to their natural condition. In these and other cases, the accused could not have availed himself directly of the use of asbestos gloves, unless we could suppose them so made as to imitate the human skin at a distance; but the fibres of that mineral may have been imbedded in a paste which applied itself readily to all the elevations and depressions of the skin.

In our own times the art of defending the hands and face, and indeed the whole body, from the action of heated iron and intense fire, has been applied to the nobler purpose of saving human life, and rescuing property from the flames. The revival and the improvement of this art we owe to the benevolence and the ingenuity of the Chevalier Aldini of Milan, who has travelled through all Europe to present this valuable gift to his species. Sir H. Davy had long ago shown that a safety lamp for illuminating mines, containing inflammable air, might be constructed of wire-gauze alone, which prevented the flame within, however large or intense, from setting fire to the inflammable air without. This valuable property, which has been long in practical use, he ascribed to the conducting and radiating power of the wire-gauze, which carried off the heat of the flame, and deprived it of its power. The Chevalier Aldini conceived the idea of applying the same material, in combination with other badly conducting substances, as a protection against fire. The incombustible pieces of dress which he uses for the body, arms, and legs, are formed out of strong cloth, which has been steeped in a solution of alum, while those for the head, hands, and feet, are made of cloth of asbestos or amianthus. The head-dress is a large cap which envelops the whole head down to the neck, having suitable perforations for the eyes, nose, and mouth. The stockings and cap are single, but the gloves are made of double amianthus cloth, to enable the fireman to take into his hand burning or red hot bodies. The piece of ancient asbestos cloth preserved in the Vatican was formed, we believe, by mixing the asbestos with other fibrous substances; but M. Aldini has executed a piece of nearly the same size, nine feet five inches long and five feet three inches wide, which is much stronger than the ancient piece, and possesses superior qualities, in consequence of having been woven without the introduction of any foreign substance. In this manufacture the fibres are prevented from breaking by the action of steam, the cloth is made loose in its fabric, and the threads are about the fiftieth of an inch in diameter.

The metallic dress which is superadded to these means of defence consists of five principal pieces, viz. a *casque* or cap, with a mask large enough to leave a proper space between it and the asbestos cap; a cuirass with its brassets; a piece of armour for the trunk and thighs; a pair of boots of double wire-gauze; and an oval shield 5 feet long by 2½ wide, made by stretching the wire-gauze over a slender frame of iron. All these pieces are made of iron wire-gauze, having the interval between its threads the twenty-fifth part of an inch.

In order to prove the efficacy of this apparatus, and inspire the firemen with confidence in its protection, he showed them that a finger first enveloped in asbestos, and then in a double case of wire-gauze, might be held a long time in the flame of a spirit-lamp or candle before the heat became inconvenient. A fireman having his hand within a double asbestos glove, and its palm protected by a piece of asbestos cloth, seized with impunity a large piece of red-hot iron, carried it deliberately to the distance of 150 feet, inflamed straw with it, and brought it back again to the furnace. On other occasions the fireman handled blazing wood and burning substances, and walked during five minutes upon an iron grating placed over flaming fagots.

In order to show how the head, eyes, and lungs are protected, the fireman put on the asbestos and wire-gauze cap, and the cuirass, and held the shield before his breast. A fire of shavings was then lighted, and kept burning in a large raised chafing-dish; the fireman plunged his head into the middle of the flames with his face to the fuel, and in that position went several times round the chafing-dish for a period longer than a minute. In a subsequent trial, at Paris, a fireman placed his head in the middle of a large brazier filled with flaming hay and wood, as in Fig. 77, and resisted the action of the fire during five or six minutes, and even ten minutes.

Fig. 77.



In the experiments which were made at Paris in the presence of a committee of the Academy of Sciences, two parallel rows of straw and brushwood, supported by iron wires, were formed at the distance of three feet from each other, and extended thirty feet in length. When this combustible mass was set on fire, it was necessary to stand at the distance of eight or ten yards to avoid the heat. The flames from both the rows seemed to fill up the whole space between them, and rose to the height of nine or ten feet. At this moment six firemen, clothed in the incombustible dresses, and marching at a slow pace behind each other, repeatedly passed through the whole length between the two rows of flame, which were constantly fed with additional combustibles. One of the firemen carried on his back a child eight years old, in a wicker-basket covered with metallic gauze, and the child had no other dress than a cap made of amianthine cloth.

In February, 1829, a still more striking experiment was made in the yard of the barracks of St. Gervais. Two towers were erected two stories high, and were surrounded with heaps of inflamed materials, consisting of fagots and straw. The firemen braved the danger with impunity. In opposition to the advice of M. Aldini, one of them, with the basket and child, rushed into a narrow place, where the flames were raging eight yards high. The violence of the fire was so great that he could not be seen, while a thick black smoke spread around, throwing out a heat which was unsupportable by the spectators. The fireman remained so long invisible that serious doubts were entertained of his safety. He at length, however, issued from the fiery gulf uninjured, and proud of having succeeded in braving so great a danger.

It is a remarkable result of these experiments, that the firemen are able to breathe without difficulty in the middle of the flames. This effect is owing not only to the heat being intercepted by the wire-gauze as it passes to the lungs, in consequence of which its temperature becomes supportable, but also to the singular power which the body possesses of resisting great heats, and of breathing air of high temperatures.

A series of curious experiments were made on this subject by M. Tillet in France, and by Dr. Fordyce and Sir Charles Blagden in England. Sir Joseph Banks, Dr. Solander, and Sir Charles Blagden entered a room in which the air had a temperature of 198° Fahr., and remained ten minutes; but as the thermometer sank very rapidly, they resolved to enter the room singly. Dr. Solander went in alone, and found the heat 210°, and Sir Joseph entered when the heat was 211°. Though exposed to such an elevated temperature, their bodies preserved their natural degree of heat. Whenever they breathed upon a thermometer it sank several degrees: every expiration, particularly if strongly made, gave a pleasant impression of coolness to their nostrils, and their cold breath cooled their fingers whenever it reached them. On touching his side, Sir Charles Blagden found it cold like a corpse, and yet the heat of his body under his tongue was 98°. Hence they concluded that the human body possesses the power of destroying a certain degree of heat when communicated with a certain degree of quickness. This power, however, varies greatly in different media. The same person who experienced no inconvenience from air heated to 211°, could just bear rectified spirits of wine at 130°, cooling oil at 129°, cooling water at 123°, and cooling quicksilver at 117°. A familiar instance of this occurred in the heated room. All the pieces of metal there, even their watch-chains, felt so hot that they could scarcely bear to touch them for a moment, while the air from which the metal had derived all its heat was only unpleasant. Messrs. Duhamel and Tillet observed, at Rochefoucault in France, that the girls who were accustomed to attend ovens in a bakehouse were capable of enduring for ten minutes a temperature of 270°.

The same gentlemen who performed the experiments above described ventured to expose themselves to still higher temperatures. Sir Charles Blagden went into a room where the heat was 1° or 2° above 260°, and remained eight minutes in this situation, frequently walking about

to all the different parts of the room, but standing still most of the time in the coolest spot, where the heat was above 240° . The air, though very hot, gave no pain, and Sir Charles and all the other gentlemen were of opinion that they could support a much greater heat. During seven minutes Sir C. Blagden's breathing continued perfectly good, but after that time he felt an oppression in his lungs, with a sense of anxiety, which induced him to leave the room. His pulse was then 144, double its ordinary quickness. In order to prove that there was no mistake respecting the degree of heat indicated by the thermometer, and that the air which they breathed was capable of producing all the well-known effects of such a heat on inanimate matter, they placed some eggs and a beef-steak upon a tin frame near the thermometer, but more distant from the furnace than from the wall of the room. In the space of twenty minutes the eggs were roasted quite hard, and in forty-seven minutes the steak was not only dressed, but almost dry. Another beef-steak, similarly placed, was rather overdone in thirty-three minutes. In the evening, when the heat was still more elevated, a third beef-steak was laid in the same place, and as they had noticed that the effect of the hot air was greatly increased by putting it in motion, they blew upon the steak with a pair of bellows, and thus hastened the dressing of it to such a degree that the greatest portion of it was found to be pretty well done in thirteen minutes.

Our distinguished countryman, Sir F. Chantrey, has very recently exposed himself to a temperature still higher than any which we have mentioned. The furnace which he employs for drying his moulds is about 14 feet long, 12 feet high, and 12 feet broad. When it is raised to its highest temperature, with the doors closed, the thermometer stands at 350° , and the iron floor is red hot. The workmen often enter it at a temperature of 340° , walking over the iron floor with wooden clogs, which are of course charred on the surface. On one occasion Sir F. Chantrey, accompanied by five or six of his friends, entered the furnace, and, after remaining two minutes, they brought out a thermometer which stood at 320° . Some of the party experienced sharp pains in the tips of their ears, and in the septum of the nose, while others felt a pain in their eyes.

LETTER XIII.

Spontaneous combustion—In the absorption of air by powdered charcoal—and of hydrogen by spongy platinum—Dobereiner's lamp—Spontaneous combustion in the bowels of the earth—Burning cliffs—Burning soil—Combustion without flame—Spontaneous combustion of human beings—Countess Zangari—Grace Pett—Natural fire-temples of the Guebres—Spontaneous fires in the Caspian Sea—Springs of inflammable gas near Glasgow—Natural light-house of Maracaybo—New elastic fluids in their cavities—of gems—Chemical operation going on in their cavities—Explosions produced in them by heat—Remarkable changes of colour from chemical causes—Effects of the nitrous oxide of Paradise gas when breathed—Remarkable cases described—Conclusion.

Among the wonderful phenomena which chemistry presents to us, there are few more remarkable than those of spontaneous combustion, in which bodies both animate and inanimate emit flames, and are sometimes entirely consumed by internal fire. One of the commonest experiments in chemistry is that of producing inflammation by mixing two fluids perfectly cold. Becker, we believe, was the first person who discovered that this singular effect was produced by mixing oil of vitriol with oil of turpentine. Borrichios showed that aqua-fortis produced the same effect as oil of vitriol. Tournefort proved that spirit of nitre and oil of sassafras took fire when mixed; and Homberg discovered that the same property was possessed by many volatile oils when mixed with spirit of nitre.

Every person is familiar with the phenomena of heat and combustion produced by fermentation. Ricks of hay and stacks of corn have been frequently consumed by the heat generated during the fermentation produced from moisture; and gunpowder-magazines, barns, and paper-mills have been often burned by the fermentation of the materials which they contained. Galen informs us that the dung of a pigeon is sufficient to set fire to a house; and he assures us that he has often seen it take fire when it had become rotten. Casati likewise relates, on good authority, that the fire which consumed the great church of Pisa was occasioned by the dung of pigeons that had for centuries built their nests under its roof.

Among the substances subject to spontaneous combustion, pulverized or finely-powdered charcoal is one of the most remarkable. During the last thirty years no fewer than four cases of the spontaneous inflammation of powdered charcoal have taken place in France. When charcoal is triturated in tuns with bronze bruisers, it is reduced into the state of the finest powder. In this condition it has the appearance of an unctuous fluid, and it occupies a space three times less than it does in rods of about six inches long. In this state of extreme division it absorbs air much more readily than it does when in rods. This absorption, which is so slow as to require several days for its completion, is accompanied with a disengagement of heat which rises from 340° to 360° nearly of Fahrenheit, and which is the true cause of the spontaneous inflammation. The inflammation commences near the centre of the mass, at the depth of five or six inches beneath its surface, and at this spot the temperature is always higher than at any other. Black charcoal, strongly distilled, heats and inflames more easily than the orange, or that which is little distilled, or than the charcoal made in boilers. The most inflammable charcoal must have a mass of at least 66lbs. avoirdupois, in order that it may be susceptible of spontaneous inflammation. With the other less inflammable varieties, the inflammation takes place only in larger masses.

The inflammation of powdered charcoal is more active in proportion to the shortness of the interval between its carbonization and trituration. The free admission of air to the surface of the charcoal is also indispensable to its spontaneous combustion.

Colonel Aubert, to whom we owe these interesting results, likewise found that when sulphur and saltpetre are added to the charcoal, it loses its power of inflaming spontaneously. But as there is still an absorption of air and a generation of heat, he is of opinion that it would not be prudent to leave these mixtures in too large masses after trituration.³⁴

A species of spontaneous combustion, perfectly analogous to that now described, but produced almost instantaneously, was discovered by Professor Dobereiner of Jena in 1824. He found that when a jet of hydrogen gas was thrown upon recently prepared spongy platinum, the metal became almost instantly red hot, and set fire to gas. In this case the minutely divided platinum acted upon the hydrogen gas in the same manner as the minutely divided charcoal acted upon common air. Heat and combustion were produced by the absorption of both gases, though in the one case the effect was instantaneous, and in the other was the result of a prolonged absorption.

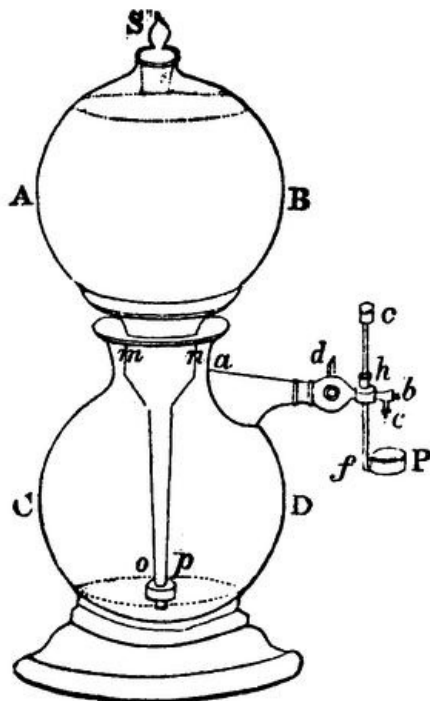

This beautiful property of spongy platinum was happily applied to the construction of lamps for producing an instantaneous light. The form given to the lamp by Mr. Garden of London is shown in the annexed figure, where AB is a globe of glass, fitting tightly into another glass globe CD by a ground shoulder *m n*. The globe AB terminates in a hollow tapering neck *m n o p*, on the lower end of which is placed a small cylinder of zinc *o p*. A brass tube *a b c*, is fitted at *a* into the neck of the globe CD, and through this tube, which is furnished with a stop-cock *d*, the gas can escape at the small aperture *c*. A brass pin *c f*, carrying a brass box P, is made to slide through a hole *h*, so that the brass box P, in which the spongy platinum is placed, can be set at any required distance from the aperture *c*. If sulphuric acid, diluted with an equal quantity of water, is now poured into the vessel AB by its mouth at S, now closed with a stopper, the fluid will descend through the tube *m n o p*, and if the cock *d* is shut, it will compress the air contained in CD. The dilute acid thus introduced into CD will act upon the ring of zinc *o p*, and generate hydrogen gas, which, after the atmospheric air in CD is let off, will gradually fill the vessel CD, the diluted acid being forced up the tube *o p m n*, into the glass globe AB. The ring of zinc *o p* floats on a piece of cork, so that when CD is full of hydrogen, the diluted acid does not touch the zinc, and consequently is prevented from producing any more gas. The instant, however, that any gas is let off at *c*, the pressure of the fluid in the globe AB, and tube *m n o p*, overcomes the elasticity of the remaining gas in CD, and forces the diluted acid up to the zinc *o p*, so as to enable it to produce more gas to supply what has been used.

The lamp being supplied with hydrogen in the manner now described, it is used in the following manner. The spongy platinum in P being brought near *c*, the cock *d* is turned, and the gas is thrown upon the platinum. An intense heat is immediately produced, the platinum becomes red-hot, and the hydrogen inflames. A taper is then lighted at the flame, and the cock *d* is shut. Professor Cumming, of Cambridge, found it necessary to cover up the platinum with a cap after every experiment. This ingenious chemist likewise found, that, with platinum foil the 9,000th part of an inch thick kept in a close tube, the hydrogen was inflamed; but when the foil was only the 6,000th of an inch thick, it was necessary to raise it previously to a red heat.

Spontaneous combustion is a phenomenon which occurs very frequently and often to a great extent within the bowels of the earth. The heat by which it is occasioned is produced by the decomposition of mineral bodies and other causes. This heat increases in intensity till it is capable of melting the solid materials which are exposed to it. Gases and aqueous vapours of powerful elasticity are generated, new fluids of expansive energy imprisoned in cavities under great pressure are set free, and these tremendous agents, acting under the repressing forces of the superincumbent strata, exhibit their power in desolating earthquakes; or, forcing their way through the superficial crust of the globe, they waste their fury in volcanic eruptions.

When the phenomena of spontaneous combustion take place near the surface of the earth, its effects are of a less dangerous character, though they frequently give birth to permanent conflagrations, which no power can extinguish. An example of this milder species of spontaneous combustion has been recently exhibited in the burning cliff at Weymouth; and a still more interesting one exists at this moment near the village of Bradley, in Staffordshire. The earth is here on fire, and this fire has continued for nearly sixty years, and has resisted every attempt that has been made to extinguish it. This fire, which has reduced many acres of land to a mere calx, arises from a burning stratum of coal about four feet thick and eight or ten yards deep, to which the air has free access, in consequence of the main coal having been dug from beneath it. The surface of the ground is sometimes covered for many yards with such quantities of sulphur that it can be easily gathered. The calx has been found to be an excellent material for the roads, and the workmen who collect it often find large beds of alum of an excellent quality.

A singular species of invisible combustion, or of combustion without flame, has been frequently noticed. I have observed this phenomenon in the small green wax tapers in common use. When the flame is blown out, the wick will continue red-hot for many hours; and if the taper were regularly and carefully uncoiled, and the room kept free from currents of air, the wick would burn on in this way till the whole of the taper is consumed. The same effects are not produced when the colour of the wax is red. In this experiment the wick, after the flame is blown out, has sufficient heat to convert the wax into vapour, and this vapour being consumed without flame, keeps the wick at its red heat. A very disagreeable vapour is produced during this imperfect combustion of the wax.

Prof. Dobereiner, of Jena, observed that, when the alcohol in a spirit of wine lamp was nearly exhausted, the wick became carbonized, and though the flame disappeared, the carbonized part of the wick became red-hot, and continued so while a drop of alcohol remained, provided the air in the room was undisturbed. On one occasion the wick continued red-hot for twenty-four hours, and a very disagreeable acid vapour was formed.

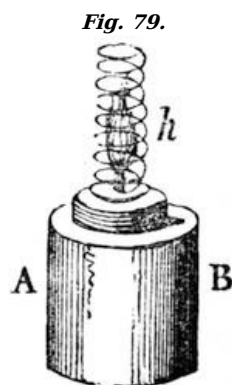

On these principles depend the *lamp without flame* which was originally constructed by Mr. Ellis. It is shown in the annexed figure, where AB is the lamp, and *h* a cylindrical coil of platinum wire, the hundredth part of an inch in diameter. This spiral is so placed that four or five of the twelve coils of which the cylinder consists are upon the wick, and the other seven or eight above it. If the lamp is lighted, and continues burning till the cylindrical coil is red-hot, then if the flame is blown out, the vapour which arises from the alcohol will by its combustion keep the coils above the wick red-hot, and this red heat will in its turn keep up the vaporization of the alcohol till the whole of the alcohol is consumed. The heat of the wire is always sufficient to kindle a piece of German fungus or saltpetre paper, so that a sulphur match may at any time be lighted. Mr. Gill found that a wick composed of twelve threads of the cotton yarn commonly used for lamps will require half an ounce of alcohol to keep the wire red-hot for eight hours. This lamp has been kept burning for sixty hours; but it can scarcely be recommended for a bed-room, as an acid vapour is disengaged during the burning of the alcohol. When perfumes are dissolved in the alcohol, they are diffused through the apartment during the slow combustion of the vapour.

A species of combustion without flame, and analogous to that which has been described, is exhibited in the extraordinary phenomenon of the spontaneous combustion of living bodies. That animal bodies are liable to internal combustion, is a fact which was well known to the ancients. Many cases which have been adduced as examples of spontaneous combustion are merely cases of individuals who were highly susceptible of strong electrical excitation. In one of these cases, however, Peter Bovisteau asserts, that the sparks of fire thus produced, reduced to ashes the hair of a young man; and John de Viana informs us, that the wife of Dr. Freilas, physician to the Cardinal de Royas, Archbishop of Toledo, emitted by perspiration an inflammable matter of such a nature, that when the ribbon which she wore over her shift was taken from her, and exposed to the cold air, it instantly took fire, and shot forth like grains of gunpowder. Peter Borelli has recorded a fact of the very same kind respecting a peasant whose linen took fire, whether it was laid up in a box when wet, or hung up in the open air. The same author speaks of a woman who, when at the point of death, vomited flames; and Thomas Bartholin mentions this phenomenon as having often happened to persons who were great drinkers of wine or brandy. Ezekiel de Castro mentions the singular case of Alexandrinus Megetius, a physician, from one of whose vertebræ there issued a fire which scorched the eyes of the beholders; and Krantzius relates, that during the wars of Godfrey of Bouillon, certain people of the territory of Nevers were burning with invisible fire, and that some of them cut off a foot or a hand where the burning began, in order to arrest the calamity. Nor have these effects been confined to man. In the time of the Roman consuls Gracchus and Juventius, a flame is said to have issued from the mouth of a bull without doing any injury to the animal.

The reader will judge of the degree of credit which may belong to these narrations when he examines the effects of a similar kind which have taken place in less fabulous ages, and nearer our own times. John Henry Cohausen informs us that a Polish gentleman in the time of the Queen Bona Sforza, having drunk two dishes of a liquor called brandy-wine, vomited flames, and was burned by them, and Thomas Bartholin³⁵ thus describes a similar accident: "A poor woman at Paris used to drink spirit of wine plentifully for the space of three years, so as to take nothing else. Her body contracted such a combustibile disposition, that one night, when she lay down on a straw couch, she was all burned to ashes except her skull and the extremities of her fingers."

John Christ. Sturmius informs us, in the German Ephemerides, that in the northern countries of Europe flames often evaporate from the stomachs of those who are addicted to the drinking of strong liquors; and he adds, "that seventeen years before, three noblemen of Courland drank by emulation strong liquors, and two of them died scorched and suffocated by a flame which issued from their stomachs."

One of the most remarkable cases of spontaneous combustion is that of the Countess Cornelia Zangari and Bandi of Cesena, which has been minutely described by the Reverend Joseph Bianchini, a prebend in the city of Verona. This lady, who is in the sixty-second year of her age, retired to bed in her usual health. Here she spent above three hours in familiar conversation with her maid, and in saying her prayers; and having at last fallen asleep, the door of her chamber was shut. As her maid was not summoned at the usual hour, she went into the bed-room to wake her mistress; but receiving no answer, she opened the window, and saw her corpse on the floor in the most dreadful condition. At the distance of four feet from the bed there was a heap of ashes. Her legs, with the stockings on, remained untouched, and the head, half burned, lay between them. Nearly all the rest of the body was reduced to ashes. The air in the room was charged with floating soot. A small oil lamp on the floor was covered with ashes, but had no oil in it; and in two candlesticks, which stood upright upon a table, the cotton wick of both the candles was left, and the tallow of both had disappeared. The bed was not injured, and the blankets and sheets were raised on one side, as if a person had risen up from it. From an examination of all the circumstances of this case, it has been generally supposed that an internal combustion had taken place; that the lady had risen from her bed to cool herself, and that, in her way to open the window, the combustion had overpowered her, and consumed her body by a process in which no flame was produced which could set fire to the furniture or the floor. The Marquis Scipio Maffei was informed by an Italian nobleman who passed through Cesena a few days after this event, that he heard it stated in that town, that the Countess Zangari was in the habit, when she felt indisposed, of washing all her body with camphorated spirit of wine.

So recently as 1744, a similar example of spontaneous combustion occurred in our own country, at Ipswich. A fisherman's wife, of the name of Grace Pett, of the parish of St. Clement's, had been in the habit for several years of going down stairs every night, after she was half undressed, to smoke a pipe. She did this on the evening of the 9th of April, 1744. Her daughter, who lay in the same bed with her, had fallen asleep, and did not miss her mother till she awaked early in the morning. Upon dressing herself, and going down stairs, she found her mother's body lying on the right side, with her head against the grate, and extended over the hearth, with her legs on the deal floor, and appearing like a block of wood burning with a glowing fire without flame. Upon quenching the fire with two bowls of water, the neighbours, whom the cries of the daughter had brought in, were almost stifled with the smell. The trunk of the unfortunate woman was almost burned to ashes, and appeared like a heap of charcoal covered with white ashes. The head, arms, legs, and thighs, were also much burned. There was no fire whatever in the grate, and the candle was burned out in the socket of the candlestick, which stood by her. The clothes of a child on one side of her, and a paper screen on the other, were untouched: and the deal floor was neither singed nor discoloured. It was said that the woman had drunk plentifully of gin overnight in welcoming a daughter who had recently returned from Gibraltar.

Among the phenomena of the natural world which are related to those of spontaneous combustion, are what have been called the natural fire-temples of the Guebres, and the igneous phenomena which are seen in their vicinity. The ancient sect of the Guebres or Parsees, distinguished from all other sects as the worshippers of fire, had their origin in Persia; but, being scattered by persecution, they sought an asylum on the shores of India. Those who refused to expatriate themselves continued to inhabit the shores of the Caspian Sea, and the cities of Ispahan, Yezd, and Kerman. Their great fire-temple, called Attush Kudda, stands in the vicinity of Badku, one of the largest and most commodious ports on the Caspian. In the neighbourhood of this town the earth is impregnated with naphtha, an inflammable mineral oil; and the inhabitants have no other fuel, and no other light, but what is derived from this substance.

The remains of the ancient fire-temples of the Guebres are still visible about ten miles to the north-east of the town. The temple in which the deity is worshipped under the form of fire, is a space about thirty yards square, surrounded with a low wall, and containing many apartments. In each of these a small volcano of sulphureous fire issues from the ground through a furnace or funnel in the shape of a Hindoo altar. On closing the funnel, the fire is instantly extinguished; and by placing the ear at the aperture, a hollow sound is heard, accompanied with a strong current of cold air, which may be lighted at pleasure by holding to it any burning substance. The flame is of a pale, clear colour, without any perceptible smoke, and emits a highly sulphureous vapour, which impedes respiration, unless when the mouth is kept beneath the level of the furnace. This action on the lungs gives the Guebres a wan and emaciated appearance, and oppresses them with a hectic cough, which strangers also feel while breathing this insalubrious atmosphere.

For about two miles in circumference, round the principal fire, the whole ground, when scraped to the depth of two or three inches, has the singular property of being inflamed by a burning coal. In this case, however, it does not communicate fire to the adjacent ground: but if the earth is dug up with a spade, and a torch brought near it, an extensive but instantaneous conflagration takes place, in which houses have often been destroyed, and the lives of the people exposed to imminent danger.

When the sky is clear and the weather serene, the springs in their ebullition do not rise higher than two or three feet; but in gloomy weather, and during the prevalence of stormy clouds, the

springs are in a state of the greatest ebullition, and the naphtha, which often takes fire spontaneously at the earth's surface, flows burning in great quantities to the sea, which is frequently covered with it, in a state of flame, to the distance of several leagues from the shore.

Besides the fires in the temple, there is a large one which springs from a natural cliff in an open situation, and which continually burns. The general space in which this volcanic fire is most abundant is somewhat less than a mile in circuit. It forms a low flat hill, sloping to the sea, the soil of which is a sandy earth, mixed with stones. Mr. Forster did not observe any violent eruption of flame in the country around the Attush Kudda; but Kinneir informs us, that the whole country round Badku has at times the appearance of being enveloped in flames. "It often seems," he adds, "as if the fire rolled down from the mountains in large masses, and with incredible velocity; and during the clear moonshine nights of November and December, a bright blue light is observed at times to cover the whole western range. The fire does not consume; and if a person finds himself in the middle of it, no warmth is felt."

The inhabitants apply these natural fires to domestic purposes, by sinking a hollow cane or merely a tube of paper, about two inches in the ground, and by blowing upon a burning coal held near the orifice of the tube, there issues a slight flame, which neither burns the cane nor the paper. By means of these canes or paper tubes, from which the fire issues, the inhabitants boil the water in their coffee-urns, and even cook different articles of food. The flame is put out by merely plugging up the orifice. The same tubes are employed for illuminating houses that are not paved. The smell of naphtha is of course diffused through the house: but after any person is accustomed to it, it ceases to be disagreeable. The inhabitants also employ this natural fire in calcining lime. The quantity of naphtha procured in the plain to the south-east of Badku is enormous. It is drawn from wells, some of which yield from 1,000 to 1,500lbs. per day. As soon as these wells are emptied, they fill again till the naphtha rises to its original level.³⁶

Inflammable gases issuing from the earth have been used both in the old and the new world for domestic purposes. In the salt mine of Gottesgabe, at Rheims, in the county of Fecklenburg, there is a pit called the *Pit of the Wind*, from which a constant current of inflammable gas has issued for sixty years. M. Roeder, the inspector of the mines, has used this gas for two years, not only as a light, but for all the purposes of domestic economy. In the pits which are not worked, he collects the gas, and conveys it in tubes to his house. It burns with a white and brilliant flame, has a density of about 0.66, and contains traces of carbonic acid gas and sulphuretted hydrogen.³⁷

Near the village of Fredonia, in North America, on the shores of Lake Erie, are a number of burning springs, as they are called. The inflammable gas which issues from these springs is conveyed in pipes to the village, which is actually lighted by them.³⁸

In the year 1828 a copious spring of inflammable gas was discovered in Scotland, in the bed of a rivulet which crosses the north road between Glasgow and Edinburgh, a little to the east of the seventh mile-stone from Glasgow, and only a few hundred yards from the house of Bedlay. The gas is said to issue for more than half a mile along the banks of the rivulet. Dr. Thompson, who has analysed the gas, saw it issuing only within a space about fifty yards in length, and about half as much in breadth. "The emission of gas was visible in a good many places along the declivity to the rivulet in the immediate neighbourhood of a small farm-house. The farmer had set the gas on fire in one place about a yard square, out of which a great many small jets were issuing. It had burnt without interruption during five weeks, and the soil (which was clay) had assumed the appearance of pounded brick all around.

"The flame was yellow and strong, and resembled perfectly the appearance which *carburetted hydrogen gas* or *fire-damp* presents when burnt in daylight. But the greatest issue of gas was in the rivulet itself, distant about twenty yards from the place where the gas was burning. The rivulet, when I visited the place, was swollen and muddy, so as to prevent its bottom from being seen. But the gas issued up through it in one place with great violence, as if it had been in a state of compression under the surface of the earth; and the thickness of the jet could not be less than two or three inches in diameter. We set the gas on fire as it issued through the water. It burnt for some time with a good deal of splendour; but as the rivulet was swollen, and rushing along with great impetuosity, the regularity of the issue was necessarily disturbed, and the gas was extinguished." Dr. Thompson found this gas to consist of *two* volumes of hydrogen gas, and *one* volume of vapour of carbon; and as its specific gravity was 0.555, and as it issues in great abundance, he remarks that it might be used for filling air-balloons. "Were we assured," he adds, "that it would continue to issue in as great abundance as at present, it might be employed in lighting the streets of Glasgow."³⁹

A very curious natural phenomenon, called the *Lantern* or *Natural Lighthouse* of Maracaybo, has been witnessed in South America. A bright light is seen every night on a mountainous and uninhabited spot on the banks of the river Catatumbo, near its junction with the Sulia. It is easily distinguished at a greater distance than *forty* leagues, and as it is nearly in the meridian of the opening of the Lake of Maracaybo, navigators are guided by it as by a light-house. This phenomenon is not only seen from the sea-coast, but also from the interior of the country—at Merida, for example, where M. Palacios observed it for two years. Some persons have ascribed this remarkable phenomenon to a thunder-storm, or to electrical explosions which might take place daily in a pass in the mountains; and it has even been asserted, that the rolling of thunder is heard by those who approach the spot. Others suppose it to be an air-volcano, like those on the

Caspian Sea, and that it is caused by asphaltic soils like those of Mena. It is more probable, however, that it is a sort of carburetted hydrogen, as hydrogen gas is disengaged from the ground in the same district.⁴⁰

Grand as the chemical operations are which are going on in the great laboratory of Nature, and alarming as their effects appear when they are displayed in the terrors of the earthquake and the volcano, yet they are not more wonderful to the philosopher than the minute though analogous operations which are often at work near our own persons, unseen and unheeded. It is not merely in the bowels of the earth that highly expansive elements are imprisoned and restrained, and occasionally called into tremendous action by the excitation of heat and other causes. Fluids and vapours of a similar character exist in the very gems and precious stones which science has contributed to luxury and to the arts.

In examining with the microscope the structure of mineral bodies, I discovered in the interior of many of the gems thousands of cavities of various forms and sizes. Some had the shape of hollow and regularly formed crystals; others possessed the most irregular outline, and consisted of many cavities and branches united without order, but all communicating with each other. These cavities sometimes occurred singly, but most frequently in groups forming strata of cavities, at one time perfectly flat and at another time curved. Several such strata were often found in the same specimen, sometimes parallel to each other, at other times inclined, and forming all varieties of angles with the faces of the original crystal.

These cavities, which occurred in *sapphire*, *chrysoberyl*, *topaz*, *beryl*, *quartz*, *amethyst*, *peridot*, and other substances, were sometimes sufficiently large to be distinctly seen by the naked eye, but most frequently they were so small as to require a high magnifying power to be well seen, and often they were so exceedingly minute, that the highest magnifying powers were unable to exhibit their outline.

Fig. 80.

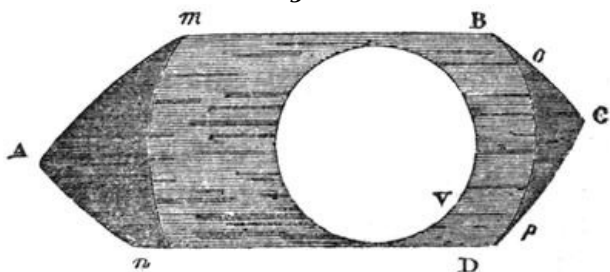

The greater number of these cavities, whether large or small, contained two new fluids different from any hitherto known, and possessing remarkable physical properties. These two fluids are in general perfectly transparent and colourless, and they exist in the same cavity in actual contact, without mixing together in the slightest degree. One of them expands *thirty* times more than water, and at a temperature of about 80° of Fahrenheit it expands so as to fill up the vacancy in the cavity. This will be understood from the annexed figure, where A B C D is the cavity, *m n p o* the highly expansible fluid in which at low temperatures there is always a vacuity V, like an air-bubble in common fluids, and *A m n, C o p*, the second fluid occupying the angles A and C. When heat such as that of the hand is applied to the specimen, the vacuity V gradually contracts in size, and wholly vanishes at a temperature of about 80°, as shown in Fig. 81. The fluids are shaded, as in these two figures, when they are seen by light reflected from their surfaces.

Fig. 81.

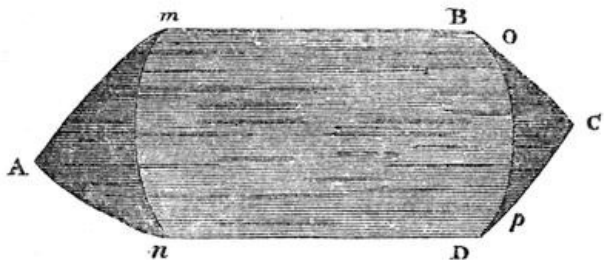
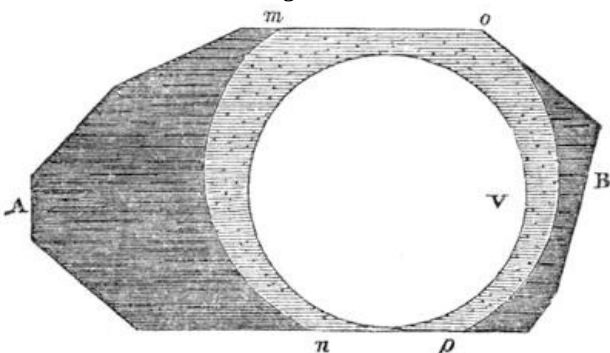

Fig. 82.



When the cavities are large, as in Fig. 82, compared with the quantity of expansible fluid $m n p o$, the heat converts the fluid into vapour, an effect which is shown by the circular cavity V becoming larger and larger till it fills the whole space $m n o p$.

When any of these cavities, whether they are filled with fluid or with vapour, is allowed to cool, the vacuity V reappears at a certain temperature. In the fluid cavities the fluid contracts, and the small vacuity appears, which grows larger and larger till it resumes its original size. When the cavities are large, several small vacuities make their appearance and gradually unite into one, though they sometimes remain separate. In deep cavities a very remarkable phenomenon accompanies the reappearance of the vacuity. At the instant that the fluid has acquired the temperature at which it quits the sides of the cavity, an effervescence or rapid ebullition takes place, and the transparent cavity is for a moment opaque, with an infinite number of minute vacuities, which instantly unite into one that goes on enlarging as the temperature diminishes. In the vapour cavities the vapour is reconverted by the cold into fluid, and the vacuity V , Fig. 82, gradually contracts till all the vapour has been precipitated. It is curious to observe, when a great number of cavities are seen at once in the field of the microscope, that the vacuities all disappear and reappear at the same instant.

While all these changes are going on in the expansive fluid, the other denser fluid at A and C , Fig. 80, 81, remains unchanged either in its form or magnitude. On this account I experienced considerable difficulty in proving that it was a fluid. The improbability of two fluids existing in a transparent state in absolute contact, without mixing in the slightest degree, or acting upon each other, induced many persons to whom I showed the phenomenon to consider the lines $m n, o p$, Fig. 80, 81, as a partition in the cavity, or the spaces $A m n, o p C$, either as filled with solid matter, or as corners into which the expanding fluid would not penetrate. The regular curvature, however, of the boundary line $m n, o p$, and other facts, rendered these suppositions untenable.

Fig. 83.

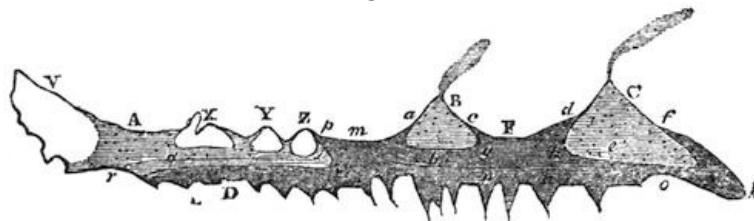

This difficulty was at last entirely removed by the discovery of a cavity of the form shown in the annexed figure, where A, B , and C are three portions of the expansible fluid separated by the interposition of the second fluid $D E F$. The first portion A of the expansible fluid had four vacuities V, X, Y, Z , while the other two portions B, C , had no vacuity. In order to determine if the vacuities of the portions B, C , had passed over to A , I took an accurate drawing of the appearances at a temperature of 50° , as shown in the figure, and I watched the changes which took place in raising the temperature to 83° . The portion A gradually expanded itself till it filled up all the four vacuities V, X, Y , and Z , but as the portions B, C , had no vacuities, they could expand themselves only by pushing back the supposed second fluid $D E F$. This effect actually took place. The dense fluid quitted the side of the cavity at F . The two portions B, C , of the expansible fluid instantly united, and the dense fluid having retreated to the limit $m n o$, its other limit advanced to $p q r$, thus proving it to be a real fluid. This experiment, which I have often shown to others, involves one of those rare combinations of circumstances which nature sometimes presents to us in order to illustrate her most mysterious operations. Had the portions B, C , been accompanied, as is usual, with their vacuities, the interposed fluid would have remained immovable between the two equal and opposite expansions; but owing to the accidental circumstance of these vacuities having passed over into the other branch A of the cavity, the fluid yielded to the difference of the expansive forces between which it lay, and thus exhibited its fluid character to the eye.

Fig. 84.

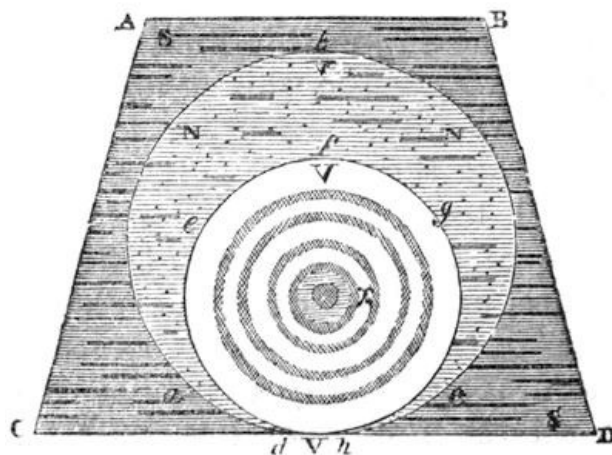

When we examine these cavities narrowly, we find that they are actually little laboratories, in

which chemical operations are constantly going on, and beautiful optical phenomena continually displaying themselves. Let A B D C, for example, be the summit of a crystallized cavity in topaz, S S representing the dense, N N the expansible fluid, bounded by a circular line *a b c d*, and V V the vacuity in the new fluid, bounded by the circle *e f g h*. If the face A B D C is placed under a compound microscope, so that light may be reflected at an angle less than that of total reflexion, and if the observer now looks through the microscope, the temperature of the room being 50°, he will see the second fluid S S shining with a very feeble reflected light, the dense fluid N N with a light perceptibly brighter, and the vacuity V V with a light of considerable brilliancy. The boundaries *a b c d*, *e f g h*, are marked by a well-defined outline, and also by the concentric coloured rings of thin plates produced by the extreme thinness of each of the fluids at their edges.

If the temperature of the room is raised slowly to 58°, a brown spot will appear at *x* in the centre of the vacuity V V. This spot indicates the commencement of evaporation from the expansible fluid below, and arises from the partial precipitation of the vapour in the roof of the cavity. As the heat increases, the brown spot enlarges and becomes very dark. It is then succeeded by a white spot and one or more coloured rings rise in the centre of the vacuity. The vapour then seems to form a drop, and all the rings disappear by retiring to the centre, but only to reappear with new lustre. During the application of heat, the circle *e f g h* contracts and dilates like the pupil of the eye. When the vaporization is so feeble as to produce only a single ring of one or two tints of the second order, they vanish instantly by breathing upon the crystal; but when the slight heat of the breath reaches the fluid, it throws off fresh vapour, and the rings again appear.

If a drop of ether is put upon the crystal when the rings are in a state of rapid play, the cold produced by its evaporation causes them to disappear, till the temperature again rises. When the temperature is perfectly uniform, the rings are stationary, as shown between V and V in fig. 84; and it is interesting to observe the first ring produced by the vapour swelling out to meet the first ring at the margin of the fluid, and sometimes coming so near it that the darkest parts of both form a broad black band. As the heat increases, the vacuity V V diminishes and disappears at 79°, exhibiting many curious phenomena, which we have not room to describe.

Having fallen upon a method of opening the cavities, and looking at the fluids, I was able to examine their properties with more attention. When the expansible fluid first rises from the cavity upon the surface of the topaz, it neither remains still like the fixed oils, nor disappears like evaporable fluids. Under the influence, no doubt, of heat and moisture, it is in a state of constant motion, now spreading itself on a thin plate over a large surface, and now contracting itself into a deeper and much less extended drop. These contractions and extensions are marked by very beautiful optical phenomena. When the fluid has stretched itself out into a thin plate, it ceases to reflect light like the thinnest part of the soap-bubble; and when it is again accumulated into a thicker drop, it is covered with thin coloured rings of thin plates.

After performing these motions, which sometimes last for ten minutes, the fluid suddenly disappears, and leaves behind it a sort of granular residue. When examining this with a single microscope, it again started into a fluid state, and extended and contracted itself as before. This was owing to the humidity of the hand which held the microscope, and I have been able to restore by moisture the fluidity of these grains twenty days after they were formed from the fluid. This portion was shown to the Rev. Dr. Fleming, who remarked, that, had he observed it accidentally, he would have ascribed its apparent vitality to the movements of some of the animals of the genus *Planaria*.

After the cavity has remained open for a day or two, the dense fluid comes out and quickly hardens into a transparent and yellowish resinous-looking substance, which absorbs moisture, though with less avidity than the other. It is not volatilized by heat, and is insoluble in water and alcohol. It readily dissolves, however, with effervescence in the sulphuric, nitric, and muriatic acids. The residue of the expansible fluid is volatilized by heat, and is dissolved, but without effervescence, in the above-mentioned acids. The refractive power of the dense fluid is about 1.295, and of the expansible one 1.131.

The particles of the dense fluid have a very powerful attraction for each other and for the mineral which contains them, while those of the expansible fluid have a very slight attraction for one another, and also for the substance of the mineral. Hence the two fluids never mix, the dense fluid being attracted to the angles of angular cavities, or filling the narrow necks by which two cavities communicate. The expansible fluid, on the other hand, fills the wide parts of the cavities, and in deep and round cavities it lies above the dense fluid.

When the dense fluid occupies the necks which join two cavities, it performs the singular function of a fluid valve, opening and shutting itself according to the expansions or contractions of the other fluid. The *fluid valves* thus exhibited in action may suggest some useful hints to the mechanic and the philosopher, while they afford ground of curious speculation in reference to the functions of animal and vegetable bodies. In the larger organizations of ordinary animals, where gravity must in general overpower, or at least modify, the influence of capillary attraction, such a mechanism is neither necessary nor appropriate; but, in the lesser functions of the same animals, and in almost all the microscopic structures of the lower world, where the force of gravity is entirely subjected to the more powerful energy of capillary forces, it is extremely probable that the mechanism of immiscible fluids and fluid valves is generally adopted.

In several cavities in minerals I have found crystallized and other bodies, sometimes transparent crystals, sometimes black spicular crystals, and sometimes black spheres, all of which are

moveable within the cavity. In some cavities the two new fluids occur in an indurated state, and others I have found to be lined with a powdery matter. This last class of cavities occurred in topaz, and they were distinguished from all others by the extraordinary beauty and symmetry of their form. One of these cavities represented a finely ornamented sceptre, and, what is still more singular, the different parts of which it is composed lay in different planes.

When the gem which contains the highly expansive fluid is strong, and the cavity not near the surface, heat may be applied to it without danger; but in the course of my experiments on this subject, the mineral has often burst with a tremendous explosion, and in one case wounded me on the brow. An accident of the same kind occurred to a gentleman who put a crystal into his mouth for the purpose of expanding the fluid. The specimen burst with great force and cut his mouth, and the fluid which was discharged from the cavity had a very disagreeable taste.

In the gems which are peculiarly appropriated for female ornaments, cavities containing the expansive fluid frequently occur, and if these cavities should happen to be very near the surface or the edge of the stone, the fever heat of the body might be sufficient to burst them with an alarming and even dangerous explosion. I have never heard of any such accident having occurred; but if it has, or if it ever shall occur, and if its naturally marvellous character shall be heightened by any calamitous results, the phenomena described in the preceding pages will strip it of its wonder.

There are no facts in chemistry more interesting than those which relate to the changes of colour, which are produced by the mixture of fluids, and to the creation of brilliant colours by the combination of bodies in which no colouring matter is visible. Facts of this kind are too common and too generally known to require to be noticed in a work like this. The art of producing such changes was known to some of the early impostors, who endeavoured to obtain a miraculous sanction to their particular dogmas. Marcos, the head of one of the sects that wished to engraft paganism upon Christianity, is said to have filled three transparent glasses with white wine, and while he prayed, the wine in one of the glasses became red like blood, that in another became purple, and that in the third sky-blue. Such transformations present no difficulty to the chemist. There are several fluids, such as some of the coloured juices of plants, which change their colour rapidly and without any additional ingredient: and in other cases, there would be no difficulty in making additions to fluids which should produce a change of colour at any required instant.

A very remarkable experiment of an analogous nature has been publicly exhibited in modern times. Professor Beyruss, who lived at the court of the Duke of Brunswick, one day pronounced to his highness that the dress which he wore should during dinner become red; and the change actually took place, to the astonishment of the prince and the rest of his guests. M. Vogel, who has recorded this curious fact, has not divulged the secret of the German chemist; but he observes, that if we pour lime-water into the juice of beet-root, we shall obtain a colourless liquid; and that a piece of white cloth dipped in this liquid and dried rapidly, will in a few hours become red by the mere contact of air. M. Vogel is also of opinion that this singular effect would be accelerated in an apartment where champagne or other fluids charged with carbonic acid are poured out in abundance.

Among the wonders of chemistry we must number the remarkable effects produced upon the human frame by the inhalation of *paradise* or *intoxicating gas*, as it has been called. This gas is known to chemists by the name of the *nitrous oxide*, or the *gaseous oxide of azote*, or the *protoxide of nitrogen*. It differs from atmospheric air only in the proportion of its ingredients, atmospheric air being composed of twenty-seven parts of oxygen, and seventy-three of nitrogen, while the nitrous oxide consists of thirty-seven parts of oxygen, and sixty-seven of nitrogen. The most convenient way of procuring the gas is to expose nitrate of ammonia in a tubulated glass retort to the heat of an Argand's lamp between 400° and 500° of Fahrenheit. The salt first melts; bubbles of gas begin to rise from the mass, and in a short time a brisk effervescence takes place, which continues till all the salt has disappeared. The products of this operation are the nitrous oxide and water, the watery vapour being condensed in the neck of the retort, while the gas is received over water. The gas thus obtained is generally white, and hence, when it is to be used for the purposes of respiration, it should remain at least an hour over water, which will absorb the small quantity of acid and of nitrate of ammonia which adhere to it. A pound of the nitrate of ammonia will in this way yield five cubic feet of gas fit for the purpose of inhalation.

It was discovered by Sir Humphrey Davy, that this gas could be safely taken into the lungs, and that it was capable of supporting respiration for a few minutes. In making this experiment he was surprised to find that it produced a singular species of intoxication, which he thus describes: "I breathed," says he, "three quarts of oxide from and into a silk bag for more than half a minute without previously closing my nose or exhausting my lungs. The first inspiration caused a slight degree of giddiness. This was succeeded by an uncommon sense of fulness in the head, accompanied with loss of distinct sensation and voluntary power, a feeling analogous to that produced in the first stage of intoxication, but unattended by pleasurable sensations." In describing the effects of another experiment, he says, "Having previously closed my nostrils and exhausted my lungs, I breathed four quarts of nitrous oxide from and into a silk bag. The first feelings were similar to those produced in the last experiment, but in less than half a minute, the respiration being continued, they diminished gradually, and were succeeded by a highly pleasurable thrilling, particularly in the chest and the extremities. The objects around me became dazzling, and my hearing more acute. Towards the last respiration the thrilling increased, the sense of muscular power became greater, and at last an irresistible propensity to action was indulged in. I recollect but indistinctly what followed; I knew that my motions were varied and

violent. These effects very rarely ceased after respiration. In ten minutes I had recovered my natural state of mind. The thrilling in the extremities continued longer than the other sensations. This experiment was made in the morning; no languor or exhaustion was consequent, my feelings through the day were as usual, and I passed the night in undisturbed repose."

In giving an account of another experiment with this gas, Sir Humphrey thus describes his feelings: "Immediately after my return from a long journey, being fatigued, I respired nine quarts of nitrous oxide, having been precisely thirty-three days without breathing any. The feelings were different from those I had experienced on former experiments. After the first six or seven respirations, I gradually began to lose the perception of external things, and a vivid and intense recollection of some former experiments passed through my mind, so that I called out, 'What an annoying concatenation of ideas!'"

Another experiment made by the same distinguished chemist was attended by still more remarkable results. He was shut up in an airtight breathing-box, having a capacity of about nine and a half cubic feet, and he allowed himself to be habituated to the excitement of the gas, which was gradually introduced. After having undergone this operation for an hour and a quarter, during which eighty quarts of gas were thrown in, he came out of the box and began to respire twenty quarts of unmingled nitrous oxide. "A thrilling," says he, "extending from the chest to the extremities, was almost immediately produced. I felt a sense of tangible extension highly pleasurable in every kind; my visible impressions were dazzling and apparently magnified; I heard distinctly every sound in the room, and I was perfectly aware of my situation. By degrees, as the pleasurable sensation increased, I lost all connexion with external things; trains of vivid visible images rapidly passed through my mind, and were connected with words in such a manner as to produce perceptions perfectly novel. I existed in a world of newly connected and newly modified ideas. When I was awakened from this same delirious trance by Dr. Kinglake, who took the bag from my mouth, indignation and pride were the first feelings produced by the sight of the persons about me. My emotions were enthusiastic and sublime, and for a moment I walked round the room, perfectly regardless of what was said to me. As I recovered my former state of mind, I felt an inclination to communicate the discoveries I had made during the experiment. I endeavoured to recall the ideas; they were feeble and indistinct. One recollection of terms, however, presented itself, and with the most intense belief and prophetic manner I exclaimed to Dr. Kinglake, 'Nothing exists but thoughts; the universe is composed of impressions, ideas, pleasures, and pains!'"

These remarkable properties induced several persons to repeat the experiment of breathing this exhilarating medicine. Its effects were, as might have been expected, various in different individuals; but its general effect was to produce in the gravest and most phlegmatic the highest degree of exhilaration and happiness unaccompanied with languor or depression. In some it created an irresistible disposition to laugh, and in others a propensity to muscular exertion. In some it impaired the intellectual functions, and in several it had no sensible effect, even when it was breathed in the purest state, and in considerable quantities. It would be an inquiry of no slight interest to ascertain the influence of this gas over persons of various bodily temperaments, and upon minds varying in their intellectual and moral character.

Although Sir Humphrey Davy experienced no unpleasant effects from the inhalation of the nitrous oxide, yet such effects are undoubtedly produced; and there is reason to believe that even permanent changes in the constitution may be induced by the operation of this remarkable stimulant. Two very interesting cases of this kind presented themselves to Professor Silliman, of Yale College, when the nitrous oxide was administered to some of his pupils. The students had been in the habit, for several years, of preparing this gas, and administering it to one another, and these two cases were the only remarkable ones which deserved to be recorded. We shall describe them in Professor Silliman's own words:—

"A gentleman, about nineteen years of age, of a sanguine temperament, and cheerful temper, and in the most perfect health, inhaled the usual quantity of the nitrous oxide, when prepared in the ordinary manner. Immediately his feelings were uncommonly elevated, so that, as he expressed it, he could not refrain from dancing and shouting. Indeed to such a degree was he excited, that he was thrown into a frightful fit of delirium, and his exertions became so violent, that after a while he sank to the earth exhausted, and there remained, until having by quiet in some degree recovered his strength, he again arose, only to renew the most convulsive muscular efforts, and the most piercing screams and cries; within a few moments, overpowered by the intensity of the paroxysm, he again fell to the ground, apparently senseless, and panting vehemently. The long continuance and violence of the affection alarmed his companions, and they ran for professional assistance. They were, however, encouraged by the person to whom they applied to hope that he would come out of his trance without injury; but for the space of two hours these symptoms continued; he was perfectly unconscious of what he was doing, and was in every respect like a maniac. He states, however, that his *feelings vibrated* between perfect happiness and the most consummate misery. In the course of the afternoon, and after the first violent effects had subsided, he was compelled to lie down two or three times from excessive fatigue, although he was immediately aroused upon any one's entering the room. The effects remained in a degree for three or four days, accompanied by a hoarseness, which he attributed to the exertion made while under the immediate influence of the gas. This case should produce a degree of caution, especially in persons of a sanguine temperament, whom, much more frequently than others, we have seen painfully, and even alarmingly affected."

The other case described by Professor Silliman was that of a man of mature age, and of a grave

and respectable character. "For nearly two years previous to his taking the gas, his health had been very delicate, and his mind frequently gloomy and depressed. This was peculiarly the case for a few days immediately preceding that time; and his general state of health was such, that he was obliged almost entirely to discontinue his studies, and was about to have recourse to medical assistance. In this state of bodily and mental debility, he inspired about three quarts of nitrous oxide. The consequences were, an astonishing invigoration of his whole system, and the most exquisite perceptions of delight. These were manifested by an uncommon disposition for pleasantry and mirth, and by extraordinary muscular power. The effects of the gas were felt without diminution for at least thirty hours, and in a greater or less degree for more than a week.

"But the most remarkable effect was that *upon the organs of taste*. Antecedently to taking the gas, he exhibited no peculiar choice in the articles of food, but immediately subsequent to that event, he *manifested a taste for such things only as were sweet*, and for several days *ate nothing but sweet cake*. Indeed this singular taste was carried to such excess, that he used *sugar and molasses, not only upon his bread and butter, and lighter food, but upon his meat and vegetables*. This he continues to do even at the present time; and although eight weeks have elapsed since he inspired the gas, he is still found *pouring molasses over beef, fish, poultry, potatoes, cabbage, or whatever animal or vegetable food is placed before him*.

"His health and spirits since that time have been uniformly good, and he attributes the restoration of his strength and mental energy to the influence of the nitrous oxide. He is entirely regular in his mind, and now experiences no uncommon exhilaration, but is habitually cheerful, while before he was as habitually grave, and even to a degree gloomy."

Such is a brief and general account of the principal phenomena of Nature, and the most remarkable deductions of science, to which the name of Natural Magic has been applied. If those who have not hitherto sought for instruction and amusement in the study of the material world, shall have found a portion of either in the preceding pages, they will not fail to extend their inquiries to other popular departments of science, even if they are less marked with the attributes of the marvellous. In every region of space, from the infinitely distant recesses of the heavens to the "dark unfathomed caves of ocean," the Almighty has erected monuments of miraculous grandeur, which proclaim the power, the wisdom, and the beneficence of their Author. The inscriptions which they bear—the hand-writing which shines upon their walls—appeal to the understanding and to the affections, and demand the admiration and the gratitude of every rational being. To remain willingly ignorant of these revelations of the Divine Power is a crime next to that of rejecting the revelation of the Divine Will. Knowledge, indeed, is at once the handmaid and the companion of true religion. They mutually adorn and support each other; and beyond the immediate circle of our secular duties, they are the only objects of rational ambition. While the calm deductions of reason regulate the ardour of Christian zeal, the warmth of a holy enthusiasm gives a fixed brightness to the glimmering lights of knowledge.

It is one of the darkest spots in the history of man, that these noble gifts have been so seldom combined. In the young mind alone can the two kindred seeds be effectually sown; and among the improvements which some of our public institutions require, we yet hope to witness a national system of instruction, in which the volumes of Nature and of Revelation shall be simultaneously perused.

D. BREWSTER.

ALLERLY, *April 24th, 1832.*

THE END.

J. HADDON, PRINTER, CASTLE STREET, FINSBURY.

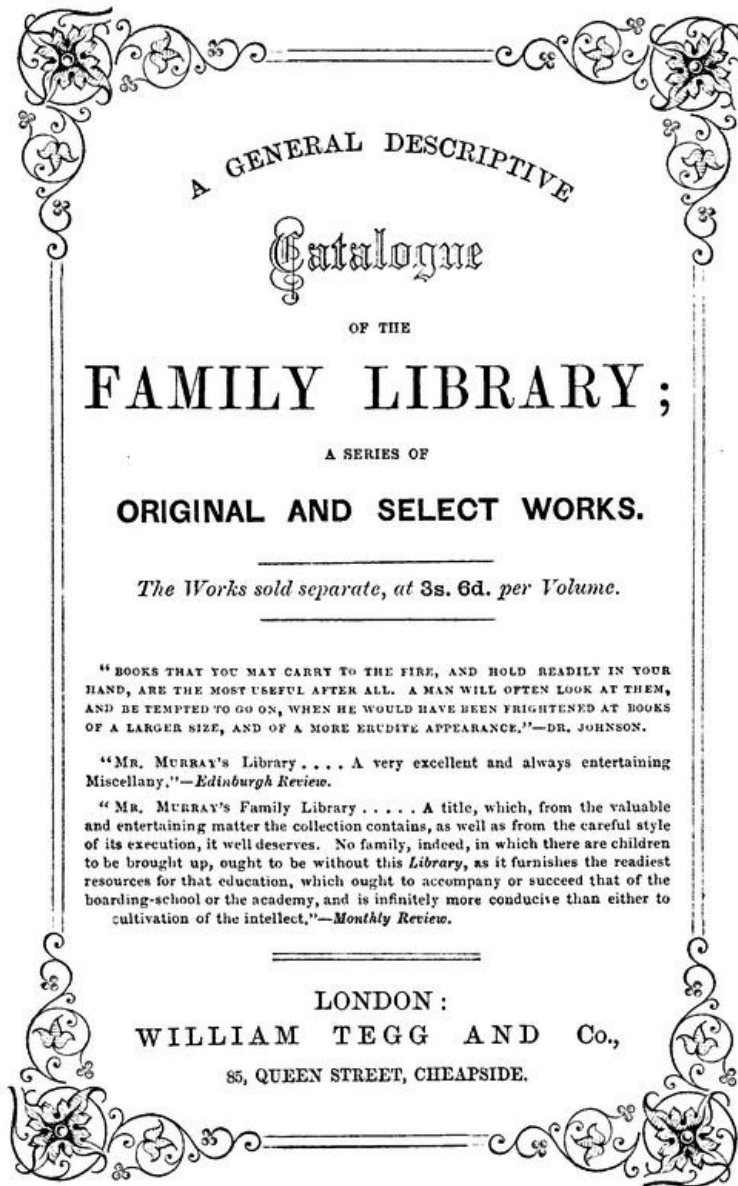

A GENERAL DESCRIPTIVE
Catalogue
OF THE
FAMILY LIBRARY;
A SERIES OF
ORIGINAL AND SELECT WORKS.

The Works sold separate, at 3s. 6d. per Volume.

"BOOKS THAT YOU MAY CARRY TO THE FIRE, AND HOLD READILY IN YOUR HAND, ARE THE MOST USEFUL AFTER ALL. A MAN WILL OFTEN LOOK AT THEM, AND BE TEMPTED TO GO ON, WHEN HE WOULD HAVE BEEN FRIGHTENED AT BOOKS OF A LARGER SIZE, AND OF A MORE ERUDITE APPEARANCE."—DR. JOHNSON.

"MR. MURRAY'S Library A very excellent and always entertaining Miscellany."—*Edinburgh Review*.

"MR. MURRAY'S Family Library A title, which, from the valuable and entertaining matter the collection contains, as well as from the careful style of its execution, it well deserves. No family, indeed, in which there are children to be brought up, ought to be without this *Library*, as it furnishes the readiest resources for that education, which ought to accompany or succeed that of the boarding-school or the academy, and is infinitely more conducive than either to cultivation of the intellect."—*Monthly Review*.

LONDON:
WILLIAM TEGG AND Co.,
85, QUEEN STREET, CHEAPSIDE.

A GENERAL DESCRIPTIVE
Catalogue
OF THE
FAMILY LIBRARY;
A SERIES OF
ORIGINAL AND SELECT WORKS.

The Works sold separate, at 3s. 6d. per Volume.

"BOOKS THAT YOU MAY CARRY TO THE FIRE, AND HOLD READILY IN YOUR HAND, ARE THE MOST USEFUL AFTER ALL. A MAN WILL OFTEN LOOK AT THEM, AND BE TEMPTED TO GO ON, WHEN HE WOULD HAVE BEEN FRIGHTENED AT BOOKS OF A LARGER SIZE, AND OF A MORE ERUDITE APPEARANCE."—DR. JOHNSON.

"MR. MURRAY'S Library.... A very excellent and always entertaining Miscellany."—*Edinburgh Review*.

"MR. MURRAY'S Family Library.... A title, which, from the valuable and entertaining matter the collection contains, as well as from the careful style of its execution, it well deserves. No family, indeed, in which there are children to be brought up, ought to be without this *Library*, as it furnishes the readiest resources for that education, which ought to accompany or succeed that of the boarding-school or the academy, and is infinitely more conducive than either to the cultivation of the intellect."—*Monthly Review*.

LONDON:
WILLIAM TEGG AND Co.,
85, QUEEN STREET, CHEAPSIDE.

ADDRESS.

It is a source of no inconsiderable gratification to find the anticipations with which the FAMILY LIBRARY was commenced exceeded by its success, and the liberal patronage bestowed on it.

The best proof of this is the fact that of many of the volumes more than 40,000 copies have been sold in this country alone. It has been warmly commended in the journals of Great Britain, in those of France, Germany, Italy, and other parts of Europe.

Its general estimation is also proved by its having been reprinted in America, and translated into most of the Continental Languages.

Upon the copyright alone of the Works of the Series, upwards of £12,000 has been expended, and the list of Contributors embraces the distinguished names of

SIR WALTER SCOTT, BART.
MR. SOUTHEY.
MR. LOCKHART.
REV. H. H. MILMAN.
WASHINGTON IRVING.
ALLAN CUNNINGHAM.
MR. TYTLER.
REV. J. WILLIAMS.
MR. BARROW (of the Admiralty).
REV. J. J. BLUNT.
REV. E. SMEDLEY.
REV. G. R. GLEIG.
SIR DAVID BREWSTER.
MR. COLERIDGE.
MAJOR SIR F. B. HEAD.
MR. DAVENPORT.
MR. CROFTON CROKER.
MR. LANDER.
CYRUS EDMONDS.
MR. BUCKE.
W. E. AYTOUN.
REV. T. CHETWODE EUSTACE.
MR. ROSCOE.
SIR FRANCIS PALGRAVE.

With the assistance of persons of such eminent talent was commenced the design of supplying the deficiencies of English Literature, by a series of Standard Works, which, with excellence of execution, should combine the advantages of lowness of price, convenience of size and form, and elegance of illustration.

While the moderate cost has placed the Work within the reach of all classes of Readers, the interesting nature of the subjects, and the popular mode of treating them, render it well suited for the perusal of Young Persons, and calculated to stimulate in them a taste for Literature and Science. In the beauty of its Embellishments, the FAMILY LIBRARY has surpassed all its Contemporaries; and no pains or cost have been spared to render each Volume as attractive externally, as it will prove entertaining and useful on perusal. With these recommendations, this Publication will be found to deserve a conspicuous place in every well-selected Library; and as it may be purchased in its complete state, or separate, *each work being complete in itself*, it will furnish valuable Literary Presents, adapted to the means and tastes of all classes of Purchasers.

The Volumes of which the FAMILY LIBRARY consists, may be classed under the following heads:—

Biography.

LIFE OF NAPOLEON.
THE COURT AND CAMP OF BUONAPARTE.
LIVES OF BRITISH PAINTERS, SCULPTORS, AND ARCHITECTS.
LIFE OF COLUMBUS.
LIVES AND ADVENTURES OF THE COMPANIONS OF COLUMBUS.
LIFE OF NELSON.
LIVES OF BRITISH PHYSICIANS.
LIFE OF BRUCE.
LIVES OF SCOTTISH WORTHIES.
LIFE OF SIR ISAAC NEWTON.
LIFE OF PETER THE GREAT.
LIFE AND TIMES OF WASHINGTON.
LIFE OF ALI PASHA.
LIFE OF DUKE OF MARLBOROUGH.
LIFE OF CERVANTES.
LIFE OF CICERO.
LIFE OF RICHARD CŒUR DE LION.
LIFE OF MAHOMET.
LIVES OF ENTERPRISING MEN.

History.

HISTORY OF THE JEWS.
HISTORY OF INDIA.
HISTORY OF VENICE.
HISTORY OF THE ANGLO-SAXONS.
REFORMATION IN ENGLAND.
TYTLER'S GENERAL HISTORY.
DE FOE'S HISTORY OF THE PLAGUE YEAR.
NARRATIVE OF NAPOLEON'S EXPEDITION TO RUSSIA.
THE RUINS OF ANCIENT CITIES.
THE MUTINY AT THE NORE.

Voyages and Travels.

LANDER'S DISCOVERIES IN AFRICA.
FAMILY TOUR IN HOLLAND.
NARRATIVE OF THE MUTINY OF THE BOUNTY.
SIX MONTHS IN THE WEST INDIES.
EUSTACE'S CLASSICAL TOUR IN ITALY.

State Trials.

TRIALS OF CHARLES THE FIRST AND THE REGICIDES.

Natural History and Science.

A POPULAR NATURAL HISTORY OF INSECTS.
LETTERS ON NATURAL MAGIC.
DEMONOLOGY AND WITCHCRAFT.
WESLEY'S NATURAL PHILOSOPHY.

Miscellaneous.

SALMAGUNDI. BY WASHINGTON IRVING.
SKETCH BOOK. BY DITTO.
CROKER'S FAIRY LEGENDS.
KNICKERBOCKER'S NEW YORK.
SKETCHES OF IMPOSTURE AND CREDULITY.
CHRONICLES OF LONDON BRIDGE.
NARRATIVES OF PERIL AND SUFFERING.

THE FAMILY LIBRARY.

A NEW HISTORY OF THE ANGLO-SAXONS.

By SIR FRANCIS PALGRAVE. *With Illustrative Woodcuts.*

This work (as the preface mentions) was intended in imitation of the *Tales of my Grandfather*. "Let me hope," the author says, "that occasionally, whilst the younger branches find amusement in the tales and adventures here brought together, some of the older folks may not be unwilling to take this little summary in hand, as a temporary substitute for the unmanageable folios produced by the unwearied industry of Saville, Twysden, and Warton, and Wilkins."

THE REFORMATION IN ENGLAND.

By the REV. J. J. BLUNT.

This is a compact but lively and entertaining sketch of the Reformation, and the personal history of the founders of our National Church.

The Reformation is one of the most remarkable events in our history, whether in relation to politics or religion; for its influence was most powerful upon both. The reading, profession, and taste of the author have led him to regard it chiefly in the latter light; and, therefore, brief as the sketch is, it will not be found of the nature of an abridgment, but a continuous though succinct account of the rise, progress, and consummation of that great revolution of the *Church of England*.

✻ This book is included in the list of works of the Society for Promoting Christian Knowledge.

THE TRIALS OF CHARLES THE FIRST, AND OF SOME OF THE REGICIDES.

With Biographies of BRADSHAW, IRETON, HARRISON, &c., and Illustrative Notes, Legal and Historical. Portrait, Views, &c.

A clear and detailed account of the most remarkable and important of English *Causes Célèbres*, with a narrative of the distinguishing events of that interesting period of our history.

HISTORY OF THE EXPEDITION TO RUSSIA UNDERTAKEN BY THE EMPEROR NAPOLEON.

By GENERAL COUNT PHILIP DE SEGUR. 2 Vols.

The established interest created by Count Segur's history renders any commendation vain—any anticipation of its contents of no value. When those recollections of the most disastrous campaign ever undertaken were first published, they were charged with exaggeration, if not falsehood; but a severe scrutiny has shown that, with the exception of a few unimportant errors, every statement in this extraordinary production is entitled to public confidence. The translation made for the Family Library exhibits evidence of the utmost care, and the misstatements into which the author inadvertently fell are corrected by the translator.

THE
LIFE OF JOHN, DUKE OF MARLBORO'.

By CHARLES BUCKE.

Editorial ingenuity, and economy in printing, have reduced the varied annals of the great Marlborough within the grasp of moderate literary industry. The editor has drawn a fair and truthful picture of the martial Duke, lauding his political and public virtues without concealing those blemishes that his warmest advocates confess to be equivocal. When the balance betwixt good and evil is struck, Marlborough stands out in bold relief in the picture of history; and had his brilliant victories been followed by firm and honest treaties, their effects, like those of Waterloo, would have been felt in the happiness of the British dominions.

THE LIFE AND WRITINGS OF MIGUEL DE CERVANTES SAAVEDRA.

With Literary and Historical Illustrations by THOS. ROSCOE, Esq.

It is not strange that the writings of Cervantes, with the exception of Don Quixote, should have so long remained unknown, since it was generally asserted that "the Spaniards had but one good book, that one which had made all the others ridiculous." The *chef-d'œuvre* is translated into every language of Europe, while the same author's plays and novels are sealed against all but Spanish scholars; and his chivalrous life, previous to this publication, buried in oblivion to which the anarchy of Spain had consigned it. Cervantes flourished in the reign of Philip II., and was contemporary with Lope de Vega.

THE LIFE OF NELSON.

By ROBERT SOUTHEY, Esq., LL.D., Poet Laureate, &c.

With numerous Woodcuts from Designs by GEORGE CRUIKSHANK, engraved by THOMPSON and WILLIAMS.

In order to promote the wishes and intention of the author, and to give the work the widest circulation, it has been printed in its present form, at *one-third of the original price*, with

embellishments by the most talented artists.

"Many Lives of Nelson have been written, but one was yet wanting, clear and concise enough to become a manual for the young sailor, which he may carry about with him till he has treasured up the example in his memory and in his heart."—*Author's Preface.*

"A work which, as long as the English language is understood, will be regarded as one of the finest monuments that genius ever raised to valour."—*Monthly Review.*

THE LIFE OF MAHOMET,
FOUNDER OF THE RELIGION OF ISLAM, AND OF THE EMPIRE OF THE SARACENS.

By REV. SAMUEL GREEN.

With the exception of the religion of the Gospel, that of Mahomet has produced the greatest revolution recorded in history, and effected the greatest changes in the state of the civilized world; its history and character, therefore, become an object of curiosity with every enlightened mind. Considered as part of the general annals of the world, unconnected with religion, it furnishes most interesting records of the human race; but viewed as part of the chain of predicted events, having a direct reference to the Christian Church, it urges a stronger claim to our attention. The events of Mahomet's life are to be found in works inaccessible from their costliness, discouraging from their bulk, and sometimes written in Eastern characters. This volume is a compilation from the most authentic.

JOURNAL
OF AN EXPEDITION TO EXPLORE THE COURSE AND TERMINATION OF THE NIGER.

By RICHARD and JOHN LANDER.

With Portraits, Engravings, and a Map, showing the course of the Niger.

With slight encouragement from the Colonial Office, these young men set out on an enterprise which in all previous instances had led to death; and all who knew the nature of the climate, and the hardships they must encounter, predicted that the only news their countrymen would ever receive concerning them, would be some obscure rumour of their destruction. The narrative shows how often such predictions were on the point of being verified. There is scarcely a misery to be endured by human nature that these young men have not encountered; they have been frequently on the brink of death—they have been imprisoned—they have been sold as slaves—they have been plundered, and obliged to swim for their lives, not sure, in the end, that they were not swimming into greater danger—and, to crown the whole, they have been brutally treated and nearly sacrificed to the cupidity and revenge of savages by one of their own countrymen. In spite of all these obstacles, by means of patience and perseverance, by enthusiasm and resignation, by courage and long-suffering, they finally triumphed over every species of resistance, and, what is more, completely gained their object.

The result of Captain Clapperton's discoveries was a very shrewd guess that the Niger flowed westward, and into the Bight of Benin. With the view of ascertaining this, the Landers were set down at the same point of the coast of Guinea where the former expedition had commenced.

THE LIFE OF MARCUS TULLIUS CICERO.

By J. F. HOLLINGS.

The name of Cicero himself—the universal admiration of his genius—the era in which he flourished—and the part he enacted, bring his memoirs within the circle of subjects suited to domestic education. His *Life*, by Middleton, is more acceptable to the learned than the learner, and this conclusion has led to this epitome, in which the text contains the uninterrupted personal memoir of the philosopher in a popular form; while such information as belongs more distinctively to the department of ancient literature is conveyed by means of notes and references.

SIX MONTHS IN THE WEST INDIES.

By HENRY NELSON COLERIDGE, M.A.

This little work, which has already received public approbation, is calculated to amuse in no ordinary degree, for the descriptions of scenery are vivid, the pictures of society graphic, and the adventures and anecdotes interesting and varied.

LIVES
OF THE MOST EMINENT BRITISH PAINTERS, SCULPTORS, AND ARCHITECTS.

By ALLAN CUNNINGHAM.

6 vols., with Portraits of Thirty-two of the most distinguished British Artists, &c.

The author has collected in six small volumes the History of Art in England, and the Lives, Characters, and Works of its Professors,—the materials for which were previously scattered through many volumes. On this account, these biographies have been considered a valuable acquisition to literature; and although the critical observations will render them valuable to the student, yet, being free from the dry technicalities of virtù, and abounding with personal anecdote, they are not less alluring to the ordinary reader.

The annals of Art, and the lives of its followers, though deficient in the spirit-stirring incidents of the warrior and the politician, possess an interest not less attractive. The labours and struggles of genius, the success of perseverance, and the inutility of natural talent separated from prudence, as exemplified in these biographies, will afford a useful moral lesson, at the same time that the perusal of the stories of such lives is a source of pleasure and entertainment.

THE HISTORY OF THE JEWS.

By REV. H. H. MILMAN. Complete in 3 vols.

With Original Maps and Woodcuts.

With the exception of Josephus, we have no historian of the Jews, and he lived at a period too remote and too limited to enable him to do justice to his subject. It is true, many events have been narrated by Rollin, and the authors of the *Universal History*, and noticed by commentators,—but a narrative at once Christian and liberal in its tone, spirited and elegant in its language, and depicting with something like kindred enthusiasm and eloquence, the manners, wars, religion, and policy of the most extraordinary of nations, was still wanting.

The object of the present work is strictly historical,—yet it affords elucidation of many obscure passages in the Old Testament; avails itself of the casual evidence of heathen writers; and throws new light on the manners and customs of the “Unchanging East,” by references to the ablest modern travellers.

THE NATURAL HISTORY OF INSECTS.

With very numerous Woodcuts. 2 vols.

The study of Natural History is at all times pleasing and instructive; the object on this occasion has been to render it doubly captivating by a plain and simple style, and by the numerous wood engravings. The extravagant price of books of Natural History has deterred many, and it is no exaggeration to assert that the information and embellishments contained in these volumes could hardly be purchased in any other form at a cost of less than several pounds.

COMPENDIUM OF NATURAL PHILOSOPHY: A SURVEY OF THE WISDOM OF GOD IN THE CREATION.

By JOHN WESLEY. A New Edition, by ROBERT MUDIE. 3 Vols.

John Wesley's name is a guarantee for the moral rectitude of the original volumes, as well as the full information which they contained at first publication; but since that time the progress of natural science has been greater than during the whole previous period of human history. Following Wesley's arrangement, the editor has incorporated the most recent discoveries, adding many new facts to those of Baron Cuvier: he has pursued the history of invertebrated animals down to the very verge of animal existence, and annexed a full account of the vegetable kingdom. The re-edited work, therefore, is not only introductory on detached portions of nature to students, but recapitulatory to such as have already consulted the details. It may not be immaterial to remark that, while controverted points are studiously avoided, the very latest discoveries are introduced, and the language employed is free from that technicality which may gratify pedantry with out promoting knowledge.

THE LIFE OF ALI PASHA OF TEPELENI VIZIER OF EPIRUS.

By R. A. DAVENPORT.

It is a common error to imagine that a greater number of individuals rise in England than in other countries; more, certainly, attain wealth and respectability under free than despotic governments; but it is under the latter only that the very humblest and most illiterate, if possessed of courage and cunning, may approach to the steps of the throne itself. Of the numerous examples which Turkish history affords, none ran a more celebrated career than Ali Pasha. Rendering himself independent by a series of rebellions, his throne was supported by the blood of thousands; yet, notwithstanding the means by which he acquired power, Napoleon treated with him,—Lord Byron was his guest,—and England accepted his friendship. Turkish history, being a record of the indulgence of the worst passions of human nature, is always a terrible romance, but the life of Ali Pasha exceeds in guilt and horror the most infamous periods of Ottoman history. The great tragedy in which he performed so principal a part, was concluded by his own assassination in the throne-room of his palace, in a manner almost too merciful for such a ferocious monster.

THE HISTORY OF BRITISH INDIA.

By the REV. G. R. GLEIG, F.R.S. 4 Vols.

With a Map and 10 Engravings.

A History of India in a portable form, and familiar style, having been considered a desideratum, the present work was undertaken. It commences with the early annals and first civilization of the Hindoos, traces the progress and decline of the Mahometan power, and brings the history of the success of the British arms down to the permanent establishment of the India Company, and the foundation of that stupendous Empire. It is among the annals of the East that the real *Romance*

of History must be sought. In the variety of marvellous incidents, the unexpected turn of events, the sudden alternation of fortune, we might fancy we were reading an Oriental fable—a tale from the Arabian Nights, rather than sober history.

SKETCHES FROM THE HISTORY OF VENICE.

With eight Views after Prout, twenty-nine Cuts after TITIAN, Maps, etc.

Few can explore for themselves the treasures of the Italian Chronicles. The author of this work has laid open their stores for the benefit of English readers,—gleaning from them characteristic incidents, amusing stories and anecdotes; while he has sustained all the dignity of historical research.

The writer has avoided the mistakes into which mere compilers fall;—he has not sunk into a mere annalist, transcribing a dry register of facts, but he either passes over entirely, or touches very slightly, events of minor importance, and reserves himself for those more momentous and interesting transactions which require to be more fully displayed. The beauty of style in which these volumes are written has attracted general notice, and the applause of the most competent judges,—in this respect, indeed, they yield to no work of the series.

LETTERS ON DEMONOLOGY AND WITCHCRAFT.

By SIR WALTER SCOTT, BART.

No subject could have been better adapted to the lamented author of “Waverley” than “the history of that dark chapter of human nature” to which this volume is devoted. Sir Walter has given sufficient evidence in his novels and romances of his acquaintance with the superstitions of our own and remoter times. In this volume he has laid open the stores of his memory and reading, has condensed and elucidated the subject; in many cases explaining by natural causes occurrences supposed to be supernatural.

LETTERS ON NATURAL MAGIC. ADDRESSED TO SIR WALTER SCOTT.

By SIR DAVID BREWSTER, K.G.H.

A New Edition, Illustrated with upwards of 80 Woodcuts.

The author of this volume passes under review “the principal phenomena of nature and the leading constructions of art which bear the impress of a supernatural character,” and more especially “those singular illusions of sense by which the most perfect organs either fail to perform their functions or perform them faithlessly, and where the efforts and the creations of the mind predominate over the direct perceptions of external nature.”

These are themes full of interest and worthy of the labour bestowed upon them by the philosophic author. It is lamentable to think how many minds rest contented with the most unphilosophical apology for ignorance, by designating the acts they do not examine, wonders or mysteries,—while to the mass of men, such acts are inexplicable, except on some theory of superhuman agency, as absurd as it is erroneous. The Letters of Sir David Brewster will disabuse both classes. To the first, he furnishes philosophical data for explaining many hitherto puzzling appearances—to the last, he supplies the means of escape from absurdities calculated to retain them in mental slavery.

The eye and the ear are of course the great organs of deception, and accordingly optical illusions occupy a considerable portion of the volume. The illusions depending on the ear succeed, and after these, we are treated with amusing descriptions of feats of strength, of mechanical automata, and of some of the more popular wonders of chemistry. Under each of these divisions, anecdotes of the most interesting kind illustrate the author’s explanations, and no subject, in itself grave and important, was ever on the whole treated in a more amusing manner.

LIFE AND TIMES OF WASHINGTON.

By CYRUS R. EDMONDS. 2 Vols.

As the foundation of the American Republic is attributable to British error, its history is identified with our own. Those who have related the events of that memorable period, and drawn the character of the patriot-general, living too near the epoch, were dazzled, and discovered only the beauty of republican principles. Written when party-feeling had died away, and limited monarchy allowed to vindicate its superiority, Mr. Edmonds’s Life of Washington is free from that nationality which disfigures biography, and fearlessly defends British institutions against the advocates of democracy. The more voluminous memoirs of the virtuous republican chief abound with American prejudices; these volumes are English both in style and sentiment.

THE LIFE OF NAPOLEON BUONAPARTE.

With 15 Engravings on Steel and Wood, by FINDEN and THOMPSON; the Woodcuts from Designs by GEO. CRUIKSHANK.

The fact that since the publication of this work, SEVEN-AND-TWENTY THOUSAND copies have been disposed of in this country, beside various editions in America,—will speak more in its favour than the most artful and high-flown praise. It is an epitome of all that has been *proved* to be true concerning the career of the most extraordinary man of the last thousand years. We

possessed no previous epitome of his history; and notwithstanding the smallness of space into which it is compressed, the narrative is clear. The Life of Napoleon, doubly interesting when relieved of the tediousness of useless detail, has never been better told. Volumes so rich in information will be devoured by youth, and are worthy to be consulted by the maturest reader.

The work is written with fairness and impartiality, free from party-spirit, and the author has interwoven with his narrative all the new illustrations and anecdotes furnished by Bourrienne and the other fast-following memoirs of the French press.

THE RUINS OF ANCIENT CITIES.

By CHARLES BUCKE. 2 Vols. *Illustrated*.

Cities, like men, flourish and decay, and each possess their annals. The poetic conception of personifying these broken records of natural grandeur originated with the editor himself; but, in carrying out his design, he acknowledges Rollin as his guide. This elegant and accurate writer confesses that he does not hesitate to rifle the cabinets of others to enrich his own; that he often transcribed without quoting, and introduced solid reflections borrowed from the sterling works of others. This compilation is also a beautiful bead-roll, the precious production of many minds: it is a fair fabric of costly materials raised by a literary architect, whose industry, experience, and candour, are already acknowledged by the public.

SALMAGUNDI; OR, THE WHIM-WHAMS AND OPINIONS OF LAUNCELOT LANGSTAFF, ESQ.

With numerous Cuts by GEORGE CRUIKSHANK.

The earliest paintings of the greatest masters sometimes differ considerably from those of their maturer years, and not unfrequently surpass them in brilliancy and freshness. If the Salmagundi Papers be compared with the subsequent works of the same author, they will not be found inferior in originality, vivacity, or virtuous tendency. While satire is the adopted weapon of chastisement, it wounds the vicious only. "We have," say the authors, "no fear of the censures of the wise, good, or fair, for they will ever be sacred from our attacks. We reverence the wise, love the good, and adore the fair: we declare ourselves champions in their cause—in the cause of morality—and we throw our gauntlet to all the world besides."

THE LIFE OF PETER THE GREAT.

By JOHN BARROW, Esq., F.R.S., *Author of the "Eventful History of the Mutiny of the Bounty." With Portrait.*

The author of this Biographical Memoir has arranged the scattered fragments of Histories, Lives, Anecdotes, and Notices, manuscript or print, of one of the most extraordinary characters that ever appeared in the world, in any age or country;—being full of contradictions, yet consistent; a promoter of literature, arts, and sciences, yet without education; "he gave a polish," says Voltaire, "to his nation, and was himself a savage;" he taught his people the art of war, of which he was himself ignorant; from the first glance of a cock-boat, five hundred miles from the sea, he became an expert ship-builder, created a fleet, partly constructed with his own hands, made himself an expert sailor, a skilful pilot, a great captain: in short, he changed the manners, the habits, the laws of the people, and the very face of the country.

SKETCHES OF IMPOSTURE, DECEPTION, AND CREDULITY.

Credulity is so comprehensive a term, that greater difficulties are encountered in selecting than multiplying examples. These "Sketches" take an extensive range over the Pagan superstitions—tell of pretended Messiahs, false prophets, and mock miracles—describe Hindoo and other Oriental deceptions in religious worship—relate of royal impostors, military stratagems, literary cheats, and commercial bubbles—unfold the mysteries of thefts and forgeries, and conclude with an interesting account of the delusions of alchemy and medical frauds. The work may be considered as a supplement to Scott's "Letters on Demonology," and Brewster's on "Natural Magic."

THE CHRONICLES OF LONDON BRIDGE.

By AN ANTIQUARY. *Illustrated*.

This is an original work, and the reader will at once perceive that the "Nominis umbra" of "An Antiquary" conceals a mind of no ordinary mould—the possessor of no common store of erudition. A velvet cushion has been the nucleus of the History of the Reformed Church—a library chair that of a history of literature. In this volume London Bridge is selected as the bond that is to bind, the avenue that is to lead from, ancient to modern London. Much valuable civic history and legend is here adorned with language, precise, classical, and nervous; while the illustrations, fifty-six in number, present more perfect reminiscences of society and manners in the olden time than the most technical and laboured descriptions.

THE LIFE OF ALEXANDER THE GREAT.

By the REV. JOHN WILLIAMS, M.A.,

Head Master of the Edinburgh Academy. Map and Woodcuts.

This volume fills a blank in the Historical Library, and furnishes a capital school-manual. It is not

confined to the mere exploits of the Macedonian hero, but contains a masterly view of the times in which he lived, and of the manners, customs, etc. of the Greeks, Persians, Egyptians, Arabs, and Indians, and other nations. The whole story is told in a manner calculated to stimulate the curiosity and rouse the reflection of the youthful reader.

THE
SKETCH BOOK OF GEOFFRY CRAYON, Esq.

2 Vols.

Had Mr. Irving left no other memorial of his genius than the Sketch Book, it would be alone sufficient to a pedestal in the Palatine Library of the XIXth. century. Justly may he contend with the "Enchanter of the North" in the rare quality of story-telling, for never was a tale more pleasantly told than "*The Legend of the Sleepy Hollow.*" Neither is there a more exquisitely beautiful or sentimental fragment in all the heart-moving scenes drawn by that able and amiable writer than Irving's sketch of "*The Broken Heart.*"

VOYAGES AND DISCOVERIES OF
THE COMPANIONS OF COLUMBUS.

By WASHINGTON IRVING. *With Illustrations.*

The extraordinary actions and adventures of these men may be said to unite romance and truth. Chivalry had left the land, and launched upon the deep in the ships of these Spanish discoverers. Contempt of danger, and fortitude of suffering, a passion for vain-glorious exploit, and a bigoted zeal for the propagation of their faith, are the characteristics of these marine heroes. The extravagant career of the daring Ojeda, particularly his adventures along the coast of Terra Firma, and the wild shores of Cuba—the sad story of Nicuessa—the singular cruise of Juan Ponce de Leon, who fell upon the coast of Florida, in his search after an imaginary fountain of youth—and above all, the chequered fortunes of Vasco Nunez de Balboa, whose discovery of the Pacific Ocean forms one of the most beautiful and striking incidents in the history of the New World,—are so many examples of knight-errantry upon the high seas. The charm of Mr. Irving's style has never been displayed more strikingly than in this little manual of true romance.

THE UNIVERSAL HISTORY FROM THE CREATION OF THE WORLD.

By ALEXANDER FRASER TYTLER, LORD WOODHOUSELEE.

6 Vols.

Perhaps few works in general literature were ever produced more synthetically, or with more vigilant caution than "The Universal History." Mr. Gilpin requested his most learned and judicious friends to criticize his MSS., and for many years they were submitted to this wholesome ordeal. The Universal History at first appeared in the form of Lectures, and was received with the most entire approbation of the students. The sketch thus carefully made for oral delivery was gradually filled up, and the picture completed in every part.

The Author's style is terse, lucid, and nervous, and his plan not only moral, but more instructive than any hitherto pursued in treating of general history.

THE LIFE OF SIR ISAAC NEWTON.

By SIR DAVID BREWSTER, LL.D., F.R.S.

Portrait and Woodcuts.

This is the only extended life of the greatest of English philosophers. In attempting to fill up this gap in our philosophic and scientific literature, Sir David Brewster has not only sought out, from resources hitherto unknown, every fresh and novel particular regarding his life, but has given the most lucid explanation of Newton's great discoveries—and has endeavoured to render these intelligible to all classes of readers.

A JOURNAL OF THE PLAGUE YEAR.

By DANIEL DE FOE.

A New Edition, with Historical Notes by E. W. BRAYLEY, F.S.A.

"From De Foe's History of the Plague we may derive more information than from all the other publications on the subject put together. He has collected all the facts attending the rise, progress, and termination of the malady; an accurate report of the number of deaths, as published by authority; a faithful account of the regulations adopted to arrest and mitigate its fury. But that which imparts life to the whole, and forms its distinguishing feature, is its descriptive imagery. The effects upon the affrighted minds of the inhabitants are depicted with all the genuine pathos of nature, without any aim at effect, but with the ease and simplicity of real life."

A CLASSICAL TOUR THROUGH ITALY.

By the REV. T. CHETWODE EUSTACE.

Seventh Edition. With great Additions and Translations of the various Quotations from Ancient and Modern Authors. 3 Vols.

It was the fate of Eustace, like that of Bruce, to see his labours rejected, and his veracity impeached; nor did these painful insinuations originate in the chance of ignorance. His honesty was also called in question. But truth in both instances eventually prevailed, and the writings of both these amiable but injured travellers are now appealed to as standard works. Eustace's Journey is not only the most accurate in topography, architecture, and politics, but is, *par excellence, the classical* tour through this land of poetry and painting. Those tourists who would soar above Eustace, have vainly sought to depreciate his learning. Those whose lot was cast below him, have gathered from his rich plumage; but neither had the courage to pass him by in silence. In this edition, which is sold at one-third the cost of the earlier ones, the discoveries made by excavation since the author's, death have been introduced.

THE EVENTFUL HISTORY OF
THE MUTINY AND PIRATICAL SEIZURE OF THE BOUNTY.

By JOHN BARROW, Esq., *Secretary to the Admiralty. With Five Plates from Original Sketches.*

"The Author of this little volume has brought into one connected view what has hitherto appeared only in detached fragments—and some of these not generally accessible—the historical narrative of an event which deeply interested the public at the time of its occurrence, and from which the naval service in particular, in all its ranks, may still draw instructive and useful lessons.

"The story in itself is replete with interest. We are taught by the Book of Sacred History, that the disobedience of our first parents entailed on our globe of earth a sinful and a suffering race; in our time there has sprung up from the most abandoned of this sinful family—from pirates, mutineers, and murderers—a little society, which, under the precepts of that sacred volume, is characterized by religion, morality, and innocence. The discovery of this happy people, as unexpected as it was accidental, and all that regards their condition and history, partake so much of the romantic, as to render the story not ill-adapted for an epic poem."—*Author's Preface.*

FAIRY LEGENDS
AND TRADITIONS OF THE SOUTH OF IRELAND.

By T. CROFTON CROKER. *With numerous Cuts.*

Fairy Tales epitomize the customs, and manners, and superstitions of a people in by-gone times, and are therefore valuable as auxiliary to the interpretation of history. Mr. Croker's Irish Legends are rich in that racy humour that characterizes his countrymen, and appear to have exhausted the traditionary treasures of the Emerald Isle. The Illustrations are also redolent of Hibernian wit and genius,—they are spirited designs, and in the happiest manner of Messrs. Brooke and Maclise, with whose merits the public are familiar.

THE LIFE AND TIMES OF RICHARD I.
SURNAMED CŒUR-DE-LION, KING OF ENGLAND.

By WILLIAM E. AYTOUN, *Author of "Bothwell," a Poem.*

None of our monarchs has achieved a wider fame than Cœur-de-Lion, yet his personal history is of all others least studied or understood. All men know that he rebelled against his father, but comparatively few are aware of the cause. All know that he conducted a crusade, and encountered Saladin; but few are acquainted with the extent of his conquests, or the causes which drove him back a fugitive to Europe. No period of the romantic ages is more interesting, or better entitled to a close examination.

NARRATIVES OF PERIL AND SUFFERING.

By R. A. DAVENPORT. *2 Vols.*

This wide field for the display of taste, talent, and general acquaintance with the history of man in his social character, has been occupied by Mr. Davenport, a veteran in elegant literature; and the popularity which his selections from the children of sorrow has acquired, is equal to that of his most successful labours. In collecting so many tales of woe and of enterprise, the author disclaims the mere vanity of having produced a work of amusement; he seeks to inculcate the salutary lesson, "that there are few things that may not be accomplished by perseverance and courage, accompanied by self-command and presence of mind."

THE LIFE OF BRUCE,
THE AFRICAN TRAVELLER.

By Major Sir FRANCIS B. HEAD, *Author of "Rough Notes," &c.*

Bruce's Travels, as originally published, occupy five quarto volumes, mixed up with Abyssinian history, and speculations on Egyptian mythology. The author has contrived to compress into this little volume the best parts of Bruce's Life and voluminous and expensive Travels, without omitting one incident of importance and interest. He has vindicated the character of Bruce, by confronting the statements of his accusers with the testimony of later travellers. The narrative had been allowed universally to possess the interest of a romance, from the graphic style in which he has described his adventures and sufferings, and the strange people and countries which he visited: but Major Head has secured for Bruce the credit of a trustworthy authority, in addition to the reputation of an entertaining narrator.

THE COURT AND CAMP OF BUONAPARTE.

This volume is a suitable and indispensable companion to the Life of Napoleon. It contains the cream "of many hundred volumes," in the shape of Memoirs, Lives, Narratives, Anecdotes, &c., connected with Buonaparte, with which the press of France has for fifteen years been teeming. It presents rapid, but vigorous sketches of the Emperor's Brothers, Wives, Sisters, Ministers, Marshals, and Generals; and those who wish for competent knowledge of "*Napoleon and his Times*," will find no work in the English language which conveys such information in a more concise shape or a more lively manner.

THE LIFE AND VOYAGES OF CHRISTOPHER COLUMBUS.

By WASHINGTON IRVING. *Abridged by him from his larger Work. With Portraits, Maps, &c.*

This little work has become a universal school-book in America. It contains all that is most important in the original, in a form more condensed, and more within the reach of the general reader; while the story is told with the same spirit and grace as in the great work. As a book of entertainment, it will bear comparison with any biographical sketch of the age.

LIVES OF EMINENT BRITISH PHYSICIANS.

With fine Portraits and Woodcuts.

The Lives of Physicians furnish a theme by no means deficient in interest and value. From them have proceeded some of the greatest benefactors of the human race; their history abounds in instances of individuals, who, obscure and small, have, by the vigour of their understanding and their perseverance, raised themselves among the great of the land. The memoirs of Cullen, Hunter, and Baillie, afford striking examples of talent and perseverance triumphing in the midst of difficulties.

Of the topics discussed in the course of this volume, the most prominent are—*The Discovery of the Circulation of the Blood*, by Harvey. *The Sweating Sickness in the time of Edward III.* *A Sketch of the Great Plague of London, in 1664-5.* *Jenner's invaluable Discovery of Vaccination.*

To this edition the names of Clutterbuck, Paris, Merriman, Chambers, and Halford, have been added.

HISTORY OF NEW YORK,
FROM THE BEGINNING OF THE WORLD TO THE END OF THE DUTCH DYNASTY.

By DIEDRICH KNICKERBOCKER. *Plates after CRUIKSHANK.*

This is a satirical production, in which the follies of the day are humorously depicted in the persons and costume of the ancient Dutch colonists who founded New York. The scene is local, the application directed to that city, to recent occurrences in the history of the United States, and of measures of the government of the Model Republic. The satire, however, is not personal, but aimed at human character and conduct, and may, therefore, be generally felt.

LIVES OF INDIVIDUALS
WHO RAISED THEMSELVES FROM POVERTY TO EMINENCE OR FORTUNE.

By R. A. DAVENPORT.

The object of this work is not merely to inculcate a moral lesson to youth, but to encourage virtue generally by creating submission to the law of opinion. When mankind perceive meritorious exertions in every rank rewarded, and in numerous instances crowned with success, they are more strongly supported in their resistance to difficulties, and more boldly encounter and conquer them. This single volume includes the most varied memoirs; whence it will appear that industry and perseverance, accompanied by rectitude of intention, obtain their merited reward in every civilized nation of our globe.

HISTORY OF THE MUTINY AT SPITHEAD AND THE NORE.

By J. NEALE, Esq., Author of "Cavendish."

With an Inquiry into its Origin and Treatment. With a Portrait of RICHARD PARKER.

Resistance to authorities necessarily enlists so few abettors, that, even when it originates in cruelty, injustice, and injury, its correction is demanded by the voice of the nation. To this feeling must be traced the flagrant partiality of our historians in describing the Mutiny of the Nore, and their misrepresentation of the causes of that calamity. Viewed at this distance of time, it is remembered as the foundation of that splendid and perfect discipline which has ever since pervaded and adorned the fleet, and as the cause for abolishing the despotic practice of impressment. But from these memorable movements legislators may receive a lesson, and learn how much more faithful freemen are than slaves to a state in danger, and more binding the ties of gratitude and affection than the terror of tyranny. This is the moral reduced from the Mutiny of the Nore in the present history.

TOUR THROUGH SOUTH HOLLAND AND UP THE RHINE.

With 10 Views, from Designs of LIEUT.-COL. BATTY.

It is strange that the history and condition of Holland should be so little known, and that it till

now should never have been made the subject of a popular work. The object of this little book is not merely to afford entertainment, but to furnish that valuable and practical information, which will render it a desirable *guide-book* to all who are tempted to take a summer's trip across Holland, up the Rhine, and through Belgium; visiting Rotterdam, the Hague, Amsterdam, Cologne, Coblenz, Frankfort, Brussels, and Antwerp.

THE LIVES OF SCOTTISH WORTHIES.

By PATRICK FRASER TYTLER, Esq. 3 Vols.

"Truth is strange, stranger than fiction."—The romantic annals of Scotland, and the characters of her ancient heroes—Wallace, Bruce, and the like,—will go far to convert this expression into an axiom.

HADDON, BROTHERS, AND CO., PRINTERS, CASTLE STREET, FINSBURY.

FOOTNOTES:

- [1](#) We must caution the young reader against some of the views given in M. Salverte's work. In his anxiety to account for everything miraculous by natural causes, he has ascribed to the same origin some of these events in sacred history which Christians cannot but regard as the result of divine agency.
- [2](#) When both eyes are open, the object whose image falls upon the insensible spot of the one eye is seen by the other, so that, though it is not invisible, yet it will only be half as luminous and, therefore two dark spots ought to be seen.
- [3](#) A very curious example of the influence of the imagination in creating distinct forms out of an irregularly shaded surface, is mentioned in the life of Peter Heaman, a Swede, who was executed for piracy and murder at Leith in 1822. We give it in his own words:—

"One remarkable thing was, one day as we mended a sail, it being a very thin one, after laying it upon deck in folds, I took the tar brush and tarred it over in the places which I thought needed to be strengthened. But when we hoisted it up, I was astonished to see that the tar I had put upon it represented a gallows and a man under it without a head. The head was lying beside him. He was complete, body, thighs, legs, arms, and in every shape like a man. Now, I oftentimes made remarks upon it, and repeated them to the others. I always said to them all, You may depend upon it that something will happen. I afterwards took down the sail on a calm day, and sewed a piece of canvas over the figure to cover it, for I could not bear to have it always before my eyes."
- [4](#) See the *Edinburgh Encyclopædia*, Art. ACCIDENTAL COLOURS.
- [5](#) *Edinburgh Journal of Science*, New Series, No. iv. pp. 218, 219, No. vi., p. 244, and No. viii., p. 261.
- [6](#) Inquiries concerning the Intellectual Powers, and the Investigation of Truth. Edinburgh, 1830.
- [7](#) *Ut speculum in loco certo positum nihil imaginet; aliorum translatus faciat imagines.* Aul. Gel. Noct. Attic., lib. xvi., cap. 18.
- [8](#) See *Edin. Encyclopædia*, Art. OPTICS, Vol. xv., p. 611.
- [9](#) Page 86.
- [10](#) Page 96.
- [11](#) A single convex lens will answer the purpose, provided we hold the eye six or eight inches behind the image of the seal formed in its conjugate focus.
- [12](#) See *Edinburgh Transactions*, vol. ix., p. 435.
- [13](#) See *Edinburgh Encyclopædia*, Art. STEEL, vol. xviii., p. 387.
- [14](#) In the Sanscrit, says Baron Humboldt, the phenomenon of the Mirage is called *Mriga Trichna*, "thirst or desire of the antelope," no doubt because this animal *Mriga*, compelled by thirst, *Trichna*, approaches those barren plains where, from the effect of unequal refraction, he thinks he perceives the undulating surface of the waters.—*Personal Narrative*, vol. iii., p. 554.
- [15](#) See J. F. Gmelin's *Gottingschen Journal der Wissenchaften*, vol. i., part iii., 1798.
- [16](#) *Edinburgh Journal of Science*, No. xviii., p. 254.
- [17](#) *Private Journal of Captain G. F. Lyon*. London, 1824, pp. 358, 361.
- [18](#) Id. p. 366.
- [19](#) See *Edinburgh Encyclopædia*, Art. SCIENCE, Curiosities in, Vol. xvii., p. 563.
- [20](#) A similar piece of mechanism had been previously made by M. le Droz.

- [21](#) See Letter XI.
- [22](#) Had M. Kempelen known the modern discovery of giving glue any degree of softness, by mixing it with molasses or sugar, which is always absorbing moisture from the atmosphere, he might have obtained a still more perfect imitation of the human organs.
- [23](#) See *Edinburgh Journal of Science*, No. viii., p. 200.
- [24](#) Description of Volcanoes, p. 170.
- [25](#) *Edinburgh Journal of Science*, New Series, No. i., p. 124.
- [26](#) Considerations on Volcanoes, and *Edinburgh Journal of Science*, No. xx., p. 261, and No. xiv., p. 265.
- [27](#) Art. SOUND, *Encycl. Metrop.*, § 110.
- [28](#) *Edinburgh Journal of Science*, No. xvii., p. 158.
- [29](#) *Revue Encyclopédique*, 1821, tome ix., p. 592.
- [30](#) See *Edinburgh Journal of Science*, No. xi., p. 153, and No. xiii., p. 51.
- [31](#) Iliad, lib. xviii., 373-378.
- [32](#) Annales Loisiliani, anno 807.
- [33](#) A popular account of this engine will be found in Mr. Babbage's interesting volume *On the Economy of Manufactures*, lately published.
- [34](#) See *Edinburgh Journal of Science*, New Series, No. viii. p. 274.
- [35](#) Acta Medica et Philosophica Hafniensia, 1673.
- [36](#) See Forster's Travels, and Kinneir's Geog. Memoir.
- [37](#) *Edinburgh Journal of Science*, No. xv., p. 183.
- [38](#) *Edinburgh Journal of Science*, No. xv., p. 183.
- [39](#) *Edinburgh Journal of Science*, No. 1, New Series, p. 71-75.
- [40](#) Humboldt's Personal Narrative, vol. iv. p. 254, note.

Transcriber's Notes

Obvious typographical errors have been silently corrected and hyphenation has been standardised. Other variations in spelling and punctuation remain unchanged.

Fig 26. precedes Fig. 25. and Fig 28. precedes Fig. 27. in the original. This sequence has been retained.

*** END OF THE PROJECT GUTENBERG EBOOK LETTERS ON NATURAL MAGIC; ADDRESSED TO SIR WALTER SCOTT, BART ***

Updated editions will replace the previous one—the old editions will be renamed.

Creating the works from print editions not protected by U.S. copyright law means that no one owns a United States copyright in these works, so the Foundation (and you!) can copy and distribute it in the United States without permission and without paying copyright royalties. Special rules, set forth in the General Terms of Use part of this license, apply to copying and distributing Project Gutenberg™ electronic works to protect the PROJECT GUTENBERG™ concept and trademark. Project Gutenberg is a registered trademark, and may not be used if you charge for an eBook, except by following the terms of the trademark license, including paying royalties for use of the Project Gutenberg trademark. If you do not charge anything for copies of this eBook, complying with the trademark license is very easy. You may use this eBook for nearly any purpose such as creation of derivative works, reports, performances and research. Project Gutenberg eBooks may be modified and printed and given away—you may do practically ANYTHING in the United States with eBooks not protected by U.S. copyright law. Redistribution is subject to the trademark license, especially commercial redistribution.

START: FULL LICENSE
 THE FULL PROJECT GUTENBERG LICENSE
 PLEASE READ THIS BEFORE YOU DISTRIBUTE OR USE THIS WORK

To protect the Project Gutenberg™ mission of promoting the free distribution of electronic works, by using or distributing this work (or any other work associated in any way with the phrase "Project Gutenberg"), you agree to comply with all the terms of the Full Project

Section 1. General Terms of Use and Redistributing Project Gutenberg™ electronic works

1.A. By reading or using any part of this Project Gutenberg™ electronic work, you indicate that you have read, understand, agree to and accept all the terms of this license and intellectual property (trademark/copyright) agreement. If you do not agree to abide by all the terms of this agreement, you must cease using and return or destroy all copies of Project Gutenberg™ electronic works in your possession. If you paid a fee for obtaining a copy of or access to a Project Gutenberg™ electronic work and you do not agree to be bound by the terms of this agreement, you may obtain a refund from the person or entity to whom you paid the fee as set forth in paragraph 1.E.8.

1.B. “Project Gutenberg” is a registered trademark. It may only be used on or associated in any way with an electronic work by people who agree to be bound by the terms of this agreement. There are a few things that you can do with most Project Gutenberg™ electronic works even without complying with the full terms of this agreement. See paragraph 1.C below. There are a lot of things you can do with Project Gutenberg™ electronic works if you follow the terms of this agreement and help preserve free future access to Project Gutenberg™ electronic works. See paragraph 1.E below.

1.C. The Project Gutenberg Literary Archive Foundation (“the Foundation” or PGLAF), owns a compilation copyright in the collection of Project Gutenberg™ electronic works. Nearly all the individual works in the collection are in the public domain in the United States. If an individual work is unprotected by copyright law in the United States and you are located in the United States, we do not claim a right to prevent you from copying, distributing, performing, displaying or creating derivative works based on the work as long as all references to Project Gutenberg are removed. Of course, we hope that you will support the Project Gutenberg™ mission of promoting free access to electronic works by freely sharing Project Gutenberg™ works in compliance with the terms of this agreement for keeping the Project Gutenberg™ name associated with the work. You can easily comply with the terms of this agreement by keeping this work in the same format with its attached full Project Gutenberg™ License when you share it without charge with others.

1.D. The copyright laws of the place where you are located also govern what you can do with this work. Copyright laws in most countries are in a constant state of change. If you are outside the United States, check the laws of your country in addition to the terms of this agreement before downloading, copying, displaying, performing, distributing or creating derivative works based on this work or any other Project Gutenberg™ work. The Foundation makes no representations concerning the copyright status of any work in any country other than the United States.

1.E. Unless you have removed all references to Project Gutenberg:

1.E.1. The following sentence, with active links to, or other immediate access to, the full Project Gutenberg™ License must appear prominently whenever any copy of a Project Gutenberg™ work (any work on which the phrase “Project Gutenberg” appears, or with which the phrase “Project Gutenberg” is associated) is accessed, displayed, performed, viewed, copied or distributed:

This eBook is for the use of anyone anywhere in the United States and most other parts of the world at no cost and with almost no restrictions whatsoever. You may copy it, give it away or re-use it under the terms of the Project Gutenberg License included with this eBook or online at www.gutenberg.org. If you are not located in the United States, you will have to check the laws of the country where you are located before using this eBook.

1.E.2. If an individual Project Gutenberg™ electronic work is derived from texts not protected by U.S. copyright law (does not contain a notice indicating that it is posted with permission of the copyright holder), the work can be copied and distributed to anyone in the United States without paying any fees or charges. If you are redistributing or providing access to a work with the phrase “Project Gutenberg” associated with or appearing on the work, you must comply either with the requirements of paragraphs 1.E.1 through 1.E.7 or obtain permission for the use of the work and the Project Gutenberg™ trademark as set forth in paragraphs 1.E.8 or 1.E.9.

1.E.3. If an individual Project Gutenberg™ electronic work is posted with the permission of the copyright holder, your use and distribution must comply with both paragraphs 1.E.1 through 1.E.7 and any additional terms imposed by the copyright holder. Additional terms will be linked to the Project Gutenberg™ License for all works posted with the permission of the copyright holder found at the beginning of this work.

1.E.4. Do not unlink or detach or remove the full Project Gutenberg™ License terms from this work, or any files containing a part of this work or any other work associated with Project Gutenberg™.

1.E.5. Do not copy, display, perform, distribute or redistribute this electronic work, or any part of this electronic work, without prominently displaying the sentence set forth in paragraph 1.E.1 with active links or immediate access to the full terms of the Project Gutenberg™ License.

1.E.6. You may convert to and distribute this work in any binary, compressed, marked up, nonproprietary or proprietary form, including any word processing or hypertext form. However, if you provide access to or distribute copies of a Project Gutenberg™ work in a format other than “Plain Vanilla ASCII” or other format used in the official version posted on the official Project Gutenberg™ website (www.gutenberg.org), you must, at no additional cost, fee or expense to the user, provide a copy, a means of exporting a copy, or a means of obtaining a copy upon request, of the work in its original “Plain Vanilla ASCII” or other form. Any alternate format must include the full Project Gutenberg™ License as specified in paragraph 1.E.1.

1.E.7. Do not charge a fee for access to, viewing, displaying, performing, copying or distributing any Project Gutenberg™ works unless you comply with paragraph 1.E.8 or 1.E.9.

1.E.8. You may charge a reasonable fee for copies of or providing access to or distributing Project Gutenberg™ electronic works provided that:

- You pay a royalty fee of 20% of the gross profits you derive from the use of Project Gutenberg™ works calculated using the method you already use to calculate your applicable taxes. The fee is owed to the owner of the Project Gutenberg™ trademark, but he has agreed to donate royalties under this paragraph to the Project Gutenberg Literary Archive Foundation. Royalty payments must be paid within 60 days following each date on which you prepare (or are legally required to prepare) your periodic tax returns. Royalty payments should be clearly marked as such and sent to the Project Gutenberg Literary Archive Foundation at the address specified in Section 4, “Information about donations to the Project Gutenberg Literary Archive Foundation.”
- You provide a full refund of any money paid by a user who notifies you in writing (or by e-mail) within 30 days of receipt that s/he does not agree to the terms of the full Project Gutenberg™ License. You must require such a user to return or destroy all copies of the works possessed in a physical medium and discontinue all use of and all access to other copies of Project Gutenberg™ works.
- You provide, in accordance with paragraph 1.F.3, a full refund of any money paid for a work or a replacement copy, if a defect in the electronic work is discovered and reported to you within 90 days of receipt of the work.
- You comply with all other terms of this agreement for free distribution of Project Gutenberg™ works.

1.E.9. If you wish to charge a fee or distribute a Project Gutenberg™ electronic work or group of works on different terms than are set forth in this agreement, you must obtain permission in writing from the Project Gutenberg Literary Archive Foundation, the manager of the Project Gutenberg™ trademark. Contact the Foundation as set forth in Section 3 below.

1.F.

1.F.1. Project Gutenberg volunteers and employees expend considerable effort to identify, do copyright research on, transcribe and proofread works not protected by U.S. copyright law in creating the Project Gutenberg™ collection. Despite these efforts, Project Gutenberg™ electronic works, and the medium on which they may be stored, may contain “Defects,” such as, but not limited to, incomplete, inaccurate or corrupt data, transcription errors, a copyright or other intellectual property infringement, a defective or damaged disk or other medium, a computer virus, or computer codes that damage or cannot be read by your equipment.

1.F.2. LIMITED WARRANTY, DISCLAIMER OF DAMAGES - Except for the “Right of Replacement or Refund” described in paragraph 1.F.3, the Project Gutenberg Literary Archive Foundation, the owner of the Project Gutenberg™ trademark, and any other party distributing a Project Gutenberg™ electronic work under this agreement, disclaim all liability to you for damages, costs and expenses, including legal fees. YOU AGREE THAT YOU HAVE NO REMEDIES FOR NEGLIGENCE, STRICT LIABILITY, BREACH OF WARRANTY OR BREACH OF CONTRACT EXCEPT THOSE PROVIDED IN PARAGRAPH 1.F.3. YOU AGREE THAT THE FOUNDATION, THE TRADEMARK OWNER, AND ANY DISTRIBUTOR UNDER THIS AGREEMENT WILL NOT BE LIABLE TO YOU FOR ACTUAL, DIRECT, INDIRECT, CONSEQUENTIAL, PUNITIVE OR INCIDENTAL DAMAGES EVEN IF YOU GIVE NOTICE OF THE POSSIBILITY OF SUCH DAMAGE.

1.F.3. LIMITED RIGHT OF REPLACEMENT OR REFUND - If you discover a defect in this electronic work within 90 days of receiving it, you can receive a refund of the money (if any) you paid for it by sending a written explanation to the person you received the work from. If

you received the work on a physical medium, you must return the medium with your written explanation. The person or entity that provided you with the defective work may elect to provide a replacement copy in lieu of a refund. If you received the work electronically, the person or entity providing it to you may choose to give you a second opportunity to receive the work electronically in lieu of a refund. If the second copy is also defective, you may demand a refund in writing without further opportunities to fix the problem.

1.F.4. Except for the limited right of replacement or refund set forth in paragraph 1.F.3, this work is provided to you 'AS-IS', WITH NO OTHER WARRANTIES OF ANY KIND, EXPRESS OR IMPLIED, INCLUDING BUT NOT LIMITED TO WARRANTIES OF MERCHANTABILITY OR FITNESS FOR ANY PURPOSE.

1.F.5. Some states do not allow disclaimers of certain implied warranties or the exclusion or limitation of certain types of damages. If any disclaimer or limitation set forth in this agreement violates the law of the state applicable to this agreement, the agreement shall be interpreted to make the maximum disclaimer or limitation permitted by the applicable state law. The invalidity or unenforceability of any provision of this agreement shall not void the remaining provisions.

1.F.6. INDEMNITY - You agree to indemnify and hold the Foundation, the trademark owner, any agent or employee of the Foundation, anyone providing copies of Project Gutenberg™ electronic works in accordance with this agreement, and any volunteers associated with the production, promotion and distribution of Project Gutenberg™ electronic works, harmless from all liability, costs and expenses, including legal fees, that arise directly or indirectly from any of the following which you do or cause to occur: (a) distribution of this or any Project Gutenberg™ work, (b) alteration, modification, or additions or deletions to any Project Gutenberg™ work, and (c) any Defect you cause.

Section 2. Information about the Mission of Project Gutenberg™

Project Gutenberg™ is synonymous with the free distribution of electronic works in formats readable by the widest variety of computers including obsolete, old, middle-aged and new computers. It exists because of the efforts of hundreds of volunteers and donations from people in all walks of life.

Volunteers and financial support to provide volunteers with the assistance they need are critical to reaching Project Gutenberg™'s goals and ensuring that the Project Gutenberg™ collection will remain freely available for generations to come. In 2001, the Project Gutenberg Literary Archive Foundation was created to provide a secure and permanent future for Project Gutenberg™ and future generations. To learn more about the Project Gutenberg Literary Archive Foundation and how your efforts and donations can help, see Sections 3 and 4 and the Foundation information page at www.gutenberg.org.

Section 3. Information about the Project Gutenberg Literary Archive Foundation

The Project Gutenberg Literary Archive Foundation is a non-profit 501(c)(3) educational corporation organized under the laws of the state of Mississippi and granted tax exempt status by the Internal Revenue Service. The Foundation's EIN or federal tax identification number is 64-6221541. Contributions to the Project Gutenberg Literary Archive Foundation are tax deductible to the full extent permitted by U.S. federal laws and your state's laws.

The Foundation's business office is located at 809 North 1500 West, Salt Lake City, UT 84116, (801) 596-1887. Email contact links and up to date contact information can be found at the Foundation's website and official page at www.gutenberg.org/contact

Section 4. Information about Donations to the Project Gutenberg Literary Archive Foundation

Project Gutenberg™ depends upon and cannot survive without widespread public support and donations to carry out its mission of increasing the number of public domain and licensed works that can be freely distributed in machine-readable form accessible by the widest array of equipment including outdated equipment. Many small donations (\$1 to \$5,000) are particularly important to maintaining tax exempt status with the IRS.

The Foundation is committed to complying with the laws regulating charities and charitable donations in all 50 states of the United States. Compliance requirements are not uniform and it takes a considerable effort, much paperwork and many fees to meet and keep up with these requirements. We do not solicit donations in locations where we have not received written confirmation of compliance. To SEND DONATIONS or determine the status of compliance for any particular state visit www.gutenberg.org/donate.

While we cannot and do not solicit contributions from states where we have not met the solicitation requirements, we know of no prohibition against accepting unsolicited donations from donors in such states who approach us with offers to donate.

International donations are gratefully accepted, but we cannot make any statements concerning tax treatment of donations received from outside the United States. U.S. laws alone swamp our small staff.

Please check the Project Gutenberg web pages for current donation methods and addresses. Donations are accepted in a number of other ways including checks, online payments and credit card donations. To donate, please visit: www.gutenberg.org/donate

Section 5. General Information About Project Gutenberg™ electronic works

Professor Michael S. Hart was the originator of the Project Gutenberg™ concept of a library of electronic works that could be freely shared with anyone. For forty years, he produced and distributed Project Gutenberg™ eBooks with only a loose network of volunteer support.

Project Gutenberg™ eBooks are often created from several printed editions, all of which are confirmed as not protected by copyright in the U.S. unless a copyright notice is included. Thus, we do not necessarily keep eBooks in compliance with any particular paper edition.

Most people start at our website which has the main PG search facility: www.gutenberg.org.

This website includes information about Project Gutenberg™, including how to make donations to the Project Gutenberg Literary Archive Foundation, how to help produce our new eBooks, and how to subscribe to our email newsletter to hear about new eBooks.