

**The Project Gutenberg eBook of Scientific American Supplement,  
No. 344, August 5, 1882, by Various**

This ebook is for the use of anyone anywhere in the United States and most other parts of the world at no cost and with almost no restrictions whatsoever. You may copy it, give it away or re-use it under the terms of the Project Gutenberg License included with this ebook or online at [www.gutenberg.org](http://www.gutenberg.org). If you are not located in the United States, you'll have to check the laws of the country where you are located before using this eBook.

Title: Scientific American Supplement, No. 344, August 5, 1882

Author: Various

Release date: August 1, 2005 [EBook #8717]  
Most recently updated: October 9, 2012

Language: English

Credits: Produced by Olaf Voss, Don Kretz, Juliet Sutherland, Charles Franks and the Distributed Proofreaders Team

\*\*\* START OF THE PROJECT GUTENBERG EBOOK SCIENTIFIC AMERICAN  
SUPPLEMENT, NO. 344, AUGUST 5, 1882 \*\*\*



**SCIENTIFIC AMERICAN  
SUPPLEMENT NO. 344**

**NEW YORK, August 5, 1882**

**Scientific American Supplement. Vol. XIV, No. 344.**

**Scientific American established 1845**

**Scientific American Supplement, \$5 a year.**

**Scientific American and Supplement, \$7 a year.**

---

**TABLE OF CONTENTS.**

- I. [ENGINEERING AND MECHANICS.--The Panama Canal. By MANUEL EISSLER. I.--Historical notes.--Spanish Discoveries in Central America.--Early explorations.--Nicaragua projects.--Panama railway, etc. Improved Averaging Machine. Compound Beam Engine. 4 figures.--Borsig's improved compound beam engine. Power Hammers with Movable Fulcrum.--By DANIEL LONGWORTH. 5 figures. The Bicheroux System of Furnaces Applied to the Puddling of Iron. 2 figures. Gessner's Continuous Cloth Pressing Machine. 3 figures. Novelties in Ring Spindles. 4 figures. Improvements in Woolen Carding Engines.](#)
- II. [NATURAL HISTORY.--Metamorphosis of the Deer's Antlers.--Annual changes. 9 figures. Monkeys. By A.R. WALLACE.--Comparison of skeletons of man, orang outang, and chimpanzee.--Other anatomical resemblances and diversities.--The different kinds of monkeys and the countries they inhabit.--American monkeys.--Lemurs. -](#)

[-Distribution, affinities, and zoological rank of monkeys.](#)

[Silk Producing Bombyces and other Lepidoptera reared in 1881. By ALFRED WAILLY, Member Lauriat de la Societe d'Acclimatation de France.--An extended and important European, Asiatic, and American silk worms, and other silk producers.](#)

- III. [MINERALOGY, METALLURGY, ETC.--The Mineralogical Localities In and Around New York City and the Minerals Occurring Therein.--By NELSON H. DARTON.--Chances for collecting within one hour's ride of New York.--Methods of collecting and testing.--Localities on Bergen Hill.--The Weehawken Tunnel.--Minerals and modes of occurrence.--Calcite.--Natrolite.--Pectolite.--Datholite. --Apopholite.--Phrenite.--Iron and copper pyrites. --Stilbite.--Laumonite.--Heulandite.](#)

[Antiseptics.](#)

[Crystallization and its Effects Upon Iron. By N.B. WOOD.-- Beauty of Crystals.-- Nature of cohesion.--Cleavage.--Growth of crystals.--Some large crystals.--Cast iron.--Influence of phosphorus and sulphur.--Nature of steel.--Burnt steel.-- Effect of annealing.](#)

- IV. [ARCHITECTURE, ART, ETC.--The Cathedral of Burgos, Spain. --Full page illustration from photograph.](#)

[Description of Burgos Cathedral.](#)

[Photo-Engraving on Zinc and Copper. By LEON VIDAL.](#)

[Meridian Line.--A surveyor's method of finding the true meridian.--By R.W. MCFARLAND.](#)

- V. [ELECTRICITY, ETC.--Electro Mania. By W. MATTIEU WILLIAMS.--Example of electrical exaggeration and delusion.--Early scientific attempts at electro-motors, electric lamps, etc.](#)

[Action of Magnets Upon the Voltaic Arc. By TH. DU MONCEL. 2 figures.](#)

[Volckmar's Secondary Batteries.](#)

---

## **METAMORPHOSIS OF THE DEER'S ANTLERS.**

Every year in March the deer loses its antlers, and fresh ones immediately begin to grow, which exceed in size those that have just been lost. Few persons probably have been able to watch and observe the habits of the animal after it has lost its antlers. It will, therefore, be of interest to examine the accompanying drawings, by Mr. L. Beckmann, one of them showing a deer while shedding its antlers, and the other as the animal appears after losing them. In the first illustration the animal has just lost one of its antlers, and fright and pain cause it to throw its head upward and become disturbed and uneasy. The remaining antler draws down one side of the head and is very inconvenient for the animal. The remaining antler becomes soon detached from its base, and the deer turns--as if ashamed of having lost its ornament and weapon--lowers its head, and sorrowfully moves to the adjoining thicket, where it hides. A friend once observed a deer losing its antlers, but the circumstances were somewhat different. The animal was jumping over a ditch, and as soon as it touched the further bank it jumped high in the air, arched its back, bent its head to one side in the manner of an animal that has been wounded, and then sadly approached the nearest thicket, in the same manner as the artist has represented in the accompanying picture. Both antlers dropped off and fell into the ditch.



#### METAMORPHOSIS OF DEER'S ANTLERS.--FIRST STAGE.

Strong antlers are generally found together, but weak ones are lost at intervals of two or three days. A few days after this loss the stumps upon which the antlers rested are covered with a skin, which grows upward very rapidly, and under which the fresh antlers are formed, so that by the end of July the bucks have new and strong antlers, from which they remove the fine hairy covering by rubbing them against young trees. It is peculiar that the huntsman, who knows everything in regard to deer, and has seventy-two signs by which he can tell whether a male or female deer passes through the woods, does not know at what age the deer gets its first antlers and how the antlers indicate the age of the animal. Prof. Altum, in Eberswalde, has given some valuable information in regard to the relation between the age of the deer and the forms of their antlers, but in some respects he has not expressed himself very clearly, and I think that my observations given in addition to his may be of importance. When the animal is a year old--that is, in June--the burrs of the antlers begin to form, and in July the animal has two protuberances of the size of walnuts, from which the first branches of the antlers rise; these branches having the length of a finger only, or being even shorter, as shown at 1, in diagram, on p. 5481. After the second year more branches are formed, which are considerably longer and much rougher at the lower ends than the first. The third pair of antlers is different from its predecessors, inasmuch as it has "roses," that is, annular ridges around the bases of the horn, which latter are now bent in the shape of a crescent. Either the antler has a single branch (Fig. 3, *a*), or besides the point it has another short end, which is a most rare shape, and is known as a "fork" (Fig. 3, *b*), or it has two forks (Fig. 3, *c*). In the following year the antlers take the form shown in Fig. 4, and then follows the antler shown in Fig. 5, *a*, which generally has "forks" in place of points, and is known as forked antler in contradistinction to the point antler shown in Fig. 5, *b*, which retains the shape of the antler, Fig. 4, but has additional or intermediate prongs or branches. The huntsmen designate the antlers by the number of ends or points on the two antlers. For instance, Fig. 4 is a six-ender; Fig. 5 shows an eight-ender, etc.; and antlers have been known to have as many as twenty-two ends. If the two antlers do not have the same number of ends the number of ends on the larger antler is multiplied by two and the word "odd" is placed before the word designating the number of ends. For instance, if one antler has three ends and the other four, the antler would be termed an "odd" eight-ender. The sixth antler shown in Fig. 6 is a ten-ender, and appears in two different forms, either with a fork at the upper end, as shown in Fig. 6, *a*, or with a crown, as shown in Fig. 6, *b*. In Fig. 7 an antler is shown which the animal carries from its seventh year until the month of March of its eighth year. From that time on the crowns only increase and change. The increase in the number of points is not always as regular as I have described it, for in years when food is scarce and poor the antlers are weak and small, and when food is plentiful and rich the antlers grow exceedingly large, and sometimes skip an entire year's growth.--Karl Brandt, in *Leipziger Illustrirte Zeitung*.

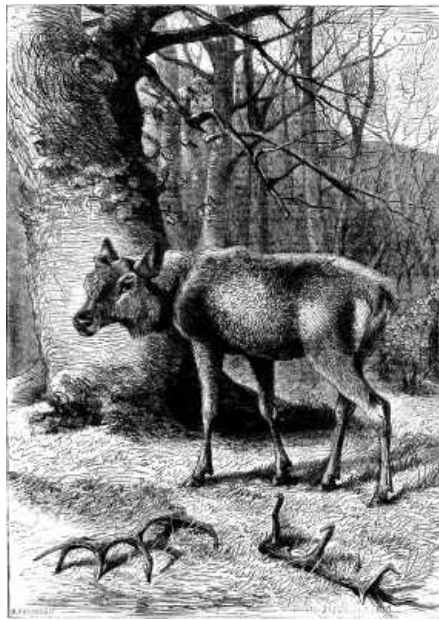

METAMORPHOSIS OF DEER'S ANTLERS.--SECOND STAGE.

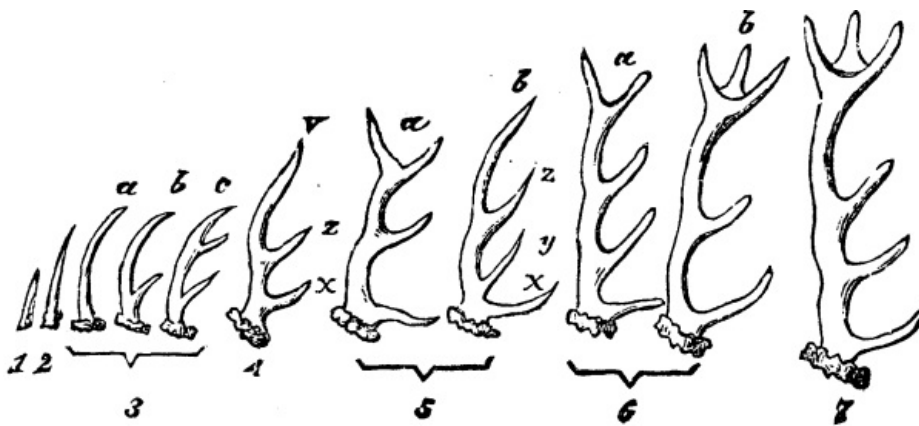

## MONKEYS.

By ALFRED R. WALLACE.

If the skeleton of an orang-outang and a chimpanzee be compared with that of a man, there will be found to be the most wonderful resemblance, together with a very marked diversity. Bone for bone, throughout the whole structure, will be found to agree in general form, position, and function, the only absolute differences being that the orang has nine wrist bones, whereas man and the chimpanzee have but eight; and the chimpanzee has thirteen pairs of ribs, whereas the orang, like man, has but twelve. With these two exceptions, the differences are those of shape, proportion, and direction only, though the resulting differences in the external form and motions are very considerable. The greatest of these are, that the feet of the anthropoid or man-like apes, as well as those of all monkeys, are formed like hands, with large opposable thumbs fitted to grasp the branches of trees, but unsuitable for erect walking, while the hands have weak, small thumbs, but very long and powerful fingers, forming a hook, rather than a hand, adapted for climbing up trees and suspending the whole weight from horizontal branches. The almost complete identity of the skeleton, however, and the close similarity of the muscles and of all the internal organs, have produced that striking and ludicrous resemblance to man, which every one recognizes in these higher apes, and, in a less degree, in the whole monkey tribe; the face and features, the motions, attitudes, and gestures being often a strange caricature of humanity. Let us, then, examine a little more closely in what the resemblance consists, and how far, and to what extent, these animals really differ from us.

Besides the face, which is often wonderfully human--although the absence of any protuberant nose gives it often a curiously infantile aspect, monkeys, and especially apes, resemble us most closely in the hand and arm. The hand has well-formed fingers, with nails, and the skin of the palm is lined and furrowed like our own. The thumb is, however, smaller and weaker than ours, and is not so much used in taking hold of anything. The monkey's hand is, therefore, not so well adapted as that of man for a variety of purposes, and cannot be applied with such precision in holding small objects, while it is unsuitable for performing delicate operations, such as tying a knot

or writing with a pen. A monkey does not take hold of a nut with its forefinger and thumb, as we do, but grasps it between the fingers and the palm in a clumsy way, just as a baby does before it has acquired the proper use of its hand. Two groups of monkeys--one in Africa and one in South America--have no thumbs on their hands, and yet they do not seem to be in any respect inferior to other kinds which possess it. In most of the American monkeys the thumb bends in the same direction as the fingers, and in none is it so perfectly opposed to the fingers as our thumbs are; and all these circumstances show that the hand of the monkey is, both structurally and functionally, a very different and very inferior organ to that of man, since it is not applied to similar purposes, nor is it capable of being so applied.

When we look at the feet of monkeys we find a still greater difference, for these have much larger and more opposable thumbs, and are therefore more like our hands; and this is the case with all monkeys, so that even those which have no thumbs on their hands, or have them small and weak and parallel to the fingers, have always large and well-formed thumbs on their feet. It was on account of this peculiarity that the great French naturalist Cuvier named the whole group of monkeys *Quadrumania*, or four-handed animals, because, besides the two hands on their fore-limbs, they have also two hands in place of feet on their hind-limbs. Modern naturalists have given up the use of this term, because they say that the hind extremities of all monkeys are really feet, only these feet are shaped like hands; but this is a point of anatomy, or rather of nomenclature, which we need not here discuss.

Let us, however, before going further, inquire into the purpose and use of this peculiarity, and we shall then see that it is simply an adaptation to the mode of life of the animals which possess it. Monkeys, as a rule, live in trees, and are especially abundant in the great tropical forests. They feed chiefly upon fruits, and occasionally eat insects and birds'-eggs, as well as young birds, all of which they find in the trees; and, as they have no occasion to come down to the ground, they travel from tree to tree by jumping or swinging, and thus pass the greater part of their lives entirely among the leafy branches of lofty trees. For such a mode of existence, they require to be able to move with perfect ease upon large or small branches, and to climb up rapidly from one bough to another. As they use their hands for gathering fruit and catching insects or birds, they require some means of holding on with their feet, otherwise they would be liable to continual falls, and they are able to do this by means of their long finger-like toes and large opposable thumbs, which grasp a branch almost as securely as a bird grasps its perch. The true hands, on the contrary, are used chiefly to climb with, and to swing the whole weight of the body from one branch or one tree to another, and for this purpose the fingers are very long and strong, and in many species they are further strengthened by being partially joined together, as if the skin of our fingers grew together as far as the knuckles. This shows that the separate action of the fingers, which is so important to us, is little required by monkeys, whose hand is really an organ for climbing and seizing food, while their foot is required to support them firmly in any position on the branches of trees, and for this purpose it has become modified into a large and powerful grasping hand.

Another striking difference between monkeys and men is that the former never walk with ease in an erect posture, but always use their arms in climbing or in walking on all-fours like most quadrupeds. The monkeys that we see in the streets dressed up and walking erect, only do so after much drilling and teaching, just as dogs may be taught to walk in the same way; and the posture is almost as unnatural to the one animal as it is to the other. The largest and most man-like of the apes--the gorilla, chimpanzee, and orang-outang--also walk usually on all-fours; but in these the arms are so long and the legs so short that the body appears half erect when walking; and they have the habit of resting on the knuckles of the hands, not on the palms like the smaller monkeys, whose arms and legs are more nearly of an equal length, which tends still further to give them a semi-erect position. Still they are never known to walk of their own accord on their hind legs only, though they can do so for short distances, and the story of their using a stick and walking erect by its help in the wild state is not true. Monkeys, then, are both four-handed and four-footed beasts; they possess four hands formed very much like our hands, and capable of picking up or holding any small object in the same manner; but they are also four-footed, because they use all four limbs for the purpose of walking, running, or climbing; and, being adapted to this double purpose, the hands want the delicacy of touch and the freedom as well as the precision of movement which ours possess. Man alone is so constructed that he walks erect with perfect ease, and has his hands free for any use to which he wishes to apply them; and this is the great and essential bodily distinction between monkeys and men.

We will now give some account of the different kinds of monkeys and the countries they inhabit.

## **THE DIFFERENT KINDS OF MONKEYS AND THE COUNTRIES THEY INHABIT.**

Monkeys are usually divided into three kinds--apes, monkeys, and baboons; but these do not include the American monkeys, which are really more different from all those of the Old World than any of the latter are from each other. Naturalists, therefore, divide the whole monkey-tribe into two great families, inhabiting the Old and the New World respectively; and, if we learn to remember the kind of differences by which these several groups are distinguished, we shall be able to understand something of the classification of animals, and the difference between important and unimportant characters.

Taking first the Old World groups, they may be thus defined: apes have no tails; monkeys have tails, which are usually long; while baboons have short tails, and their faces, instead of being round and with a man-like expression as in apes and monkeys, are long and more dog-like. These differences are, however, by no means constant, and it is often difficult to tell whether an animal should be classed as an ape, a monkey, or a baboon. The Gibraltar ape, for example, though it has no tail, is really a monkey, because it has callosities, or hard pads of bare skin on which it sits, and cheek pouches in which it can stow away food; the latter character being always absent in the true apes, while both are present in most monkeys and baboons. All these animals, however, from the largest ape to the smallest monkey, have the same number of teeth as we have, and they are arranged in a similar manner, although the tusks or canine teeth of the males are often large, like those of a dog.

The American monkeys, on the other hand, with the exception of the marmosets, have four additional grinding teeth (one in each jaw on either side), and none of them have callosities, or cheek pouches. They never have prominent snouts like the baboons; their nostrils are placed wide apart and open sideways on the face; the tail, though sometimes short, is never quite absent; and the thumb bends the same way as the fingers, is generally very short and weak, and is often quite wanting. We thus see that these American monkeys differ in a great number of characters from those of the Eastern hemisphere; and they have this further peculiarity, that many of them have prehensile or grasping tails, which are never found in the monkeys of any other country. This curious organ serves the purpose of a fifth hand. It has so much muscular power that the animal can hang by it easily with the tip curled round a branch, while it can also be used to pick up small objects with almost as much ease and exactness as an elephant's trunk. In those species which have it most perfectly formed it is very long and powerful, and the end has the underside covered with bare skin, exactly resembling that of the finger or palm of the hand and apparently equally sensitive. One of the common kinds of monkeys that accompany street organ-players has a prehensile tail, but not of the most perfect kind; since in this species the tail is entirely clad with hair to the tip, and seems to be used chiefly to steady the animal when sitting on a branch by being twisted round another branch near it. The statement is often erroneously made that all American monkeys have prehensile tails; but the fact is that rather less than half the known kinds have them so, the remainder having this organ either short and bushy, or long and slender, but entirely without any power of grasping. All prehensile-tailed monkeys are American, but all American monkeys are not prehensile-tailed.

By remembering these characters it is easy, with a little observation, to tell whether any strange monkey comes from America or from the Old World. If it has bare seat-pads, or if when eating it fills its mouth till its cheeks swell out like little bags, we may be sure it comes from some part of Africa or Asia; while if it can curl up the end of its tail so as to take hold of anything, it is certainly American. As all the tailed monkeys of the Old World have seat-pads (or ischial callosities as they are called in scientific language), and as all the American monkeys have tails, but no seat-pads, this is the most constant external character by which to distinguish them; and having done so we can look for the other peculiarities of the American monkeys, especially the distance apart of the nostrils and their lateral position.

The whole monkey-tribe is especially tropical, only a few kinds being found in the warmer parts of the temperate zone. One inhabits the Rock of Gibraltar, and there is one very like it in Japan, and these are the two monkeys which live furthest from the equator. In the tropics they become very abundant and increase in numbers and variety as we approach the equator, where the climate is hot, moist, and equable, and where flowers, fruits, and insects are to be found throughout the year. Africa has about 55 different kinds, Asia and its islands about 60, while America has 114, or almost exactly the same as Asia and Africa together. Australia and its islands have no monkeys, nor has the great and luxuriant island of New Guinea, whose magnificent forests seem so well adapted for them. We will now give a short account of the different kinds of monkeys inhabiting each of the tropical continents.

Africa possesses two of the great man-like apes--the gorilla and the chimpanzee, the former being the largest ape known, and the one which, on the whole, perhaps most resembles man, though its countenance is less human than that of the chimpanzee. Both are found in West Africa, near the equator, but they also inhabit the interior wherever there are great forests; and Dr. Schweinfurth states that the chimpanzee

inhabits the country about the sources of the Shari River in 28° E. long. and 4° N. lat.

The long-tailed monkeys of Africa are very numerous and varied. One group has no cheek pouches and no thumb on the hand, and many of these have long soft fur of varied colors. The most numerous group are the Guenons, rather small long-tailed monkeys, very active and lively, and often having their faces curiously marked with white or black, or ornamented with whiskers or other tufts of hair; and they all have large cheek pouches and good sized thumbs. Many of them are called green monkeys, from the greenish yellow tint of their fur, and most of them are well formed, pleasing animals. They are found only in tropical Africa.

The baboons are larger but less numerous. They resemble dogs in the general form and the length of the face or snout, but they have hands with well-developed thumbs on both the fore and hind limbs; and this, with something in the expression of the face and their habit of sitting up and using their hands in a very human fashion, at once shows that they belong to the monkey tribe. Many of them are very ugly, and in their wild state they are the fiercest and most dangerous of monkeys. Some have the tail very long, others of medium length, while it is sometimes reduced to a mere stump, and all have large cheek pouches and bare seat pads. They are found all over Africa, from Egypt to the Cape of Good Hope; while one species, called the hamadryas, extends from Abyssinia across the Red Sea into Arabia, and is the only baboon found out of Africa. This species was known to the ancients, and it is often represented in Egyptian sculptures, while mummies of it have been found in the catacombs. The largest and most remarkable of all the baboons is the mandrill of West Africa, whose swollen and hog-like face is ornamented with stripes of vivid blue and scarlet. This animal has a tail scarcely two inches long, while in size and strength it is not much inferior to the gorilla. The large baboons go in bands, and are said to be a match for any other animals in the African forests, and even to attack and drive away the elephants from the districts they inhabit.

Turning now to Asia, we have first one of the best known of the large man-like apes--the orang-outang, found only in the two large islands, Borneo and Sumatra. The name is Malay, signifying "man of the woods," and it should be pronounced *orang-óotan*, the accent being on the first syllable of both words. It is a very curious circumstance that, whereas the gorilla and chimpanzee are both black, like the negroes of the same country, the orang-outang is red or reddish brown, closely resembling the color of the Malays and Dyaks who live in the Bornean forests. Though very large and powerful, it is a harmless creature, feeding on fruit, and never attacking any other animal except in self-defense. A full-grown male orang-outang is rather more than four feet high, but with a body as large as that of a stout man, and with enormously long and powerful arms.

Another group of true apes inhabit Asia and the larger Asiatic islands, and are in some respects the most remarkable of the whole family. These are the Gibbons, or long-armed apes, which are generally of small size and of a gentle disposition, but possessing the most wonderful agility. In these creatures the arms are as long as the body and legs together, and are so powerful that a gibbon will hang for hours suspended from a branch, or swing to and fro and then throw itself a great distance through the air. The arms, in fact, completely take the place of the legs for traveling. Instead of jumping from bough to bough and running on the branches, like other apes and monkeys, the gibbons move along while hanging suspended in the air, stretching their arms from bough to bough, and thus going hand over hand as a very active sailor will climb along a rope. The strength of their arms is, however, so prodigious, and their hold so sure, that they often loose one hand before they have caught a bough with the other, thus seeming almost to fly through the air by a series of swinging leaps; and they travel among the network of interlacing boughs a hundred feet above the earth with as much ease and certainty as we walk or run upon level ground, and with even greater speed. These little animals scarcely ever come down to the ground of their own accord; but when obliged to do so they run along almost erect, with their long arms swinging round and round, as if trying to find some tree or other object to climb upon. They are the only apes who naturally walk without using their hands as well as their feet; but this does not make them more like men, for it is evident that the attitude is not an easy one, and is only adopted because the arms are habitually used to swing by, and are therefore naturally held upward, instead of downward, as they must be when walking on them.

The tailed monkeys of Asia consist of two groups, the first of which have no cheek pouches, but always have very long tails, They are true forest monkeys, very active and of a shy disposition. The most remarkable of these is the long-nosed monkey of Borneo, which is very large, of a pale brown color, and distinguished by possessing a long, pointed, fleshy nose, totally unlike that of all other monkeys. Another interesting species is the black and white entellus monkey of India, called the "Hanuman," by the Hindoos, and considered sacred by them. These animals are petted and fed, and at some of the temples numbers of them come every day for the food which the priests, as well as the people, provide for them.

The next group of Eastern monkeys are the Macaques, which are more like baboons, and often run upon the ground. They are more bold and vicious than the others. All have cheek pouches, and though some have long tails, in others the tail is short, or reduced to a mere stump. In some few this stump is so very short that there appears to be no tail, as in the magot of North Africa and Gibraltar, and in an allied species that inhabits Japan.

## AMERICAN MONKEYS.

The monkeys which inhabit America form three very distinct groups: 1st, the Sapajous, which have prehensile or grasping tails; 2nd, the Sagouins, which have ordinary tails, either long or short; and, 3rd, the Marmosets, very small creatures, with sharp claws, long tails which are not prehensile, and a smaller number of teeth than all other American monkeys. Each of these three groups contain several sub-groups, or *genera*, which often differ remarkably from each other, and from all the monkeys of the Old World.

We will begin with the howling monkeys, which are the largest found in America, and are celebrated for the loud voice of the males. Often in the great forests of the Amazon or Oronooko a tremendous noise is heard in the night or early morning, as if a great assemblage of wild beasts were all roaring and screaming together. The noise may be heard for miles, and it is louder and more piercing than that of any other animals, yet it is all produced by a single male howler, sitting on the branches of some lofty tree. They are enabled to make this extraordinary noise by means of an organ that is possessed by no other animal. The lower jaw is unusually deep, and this makes room for a hollow bony vessel about the size of a large walnut, situated under the root of the tongue, and having an opening into the windpipe by which the animal can force air into it. This increases the power of its voice, acting something like the hollow case of a violin, and producing those marvelous rolling and reverberating sounds which caused the celebrated traveler Waterton to declare that they were such as might have had their origin in the infernal regions. The howlers are large and stout bodied monkeys, with bearded faces, and very strong and powerfully grasping tails. They inhabit the wildest forests; they are very shy, and are seldom taken captive, though they are less active than many other American monkeys.

Next come the spider monkeys, so called from their slender bodies and enormously long limbs and tail. In these monkeys the tail is so long, strong, and perfect, that it completely takes the place of a fifth hand. By twisting the end of it round a branch the animal can swing freely in the air with complete safety; and this gives them a wonderful power of climbing and passing from tree to tree, because the distance they can stretch is that of the tail, body, and arm added together, and these are all unusually long. They can also swing themselves through the air for great distances, and are thus able to pass rapidly from tree to tree without ever descending to the ground, just like the gibbons in the Malayan forests. Although capable of feats of wonderful agility, the spider monkeys are usually slow and deliberate in their motions, and have a timid, melancholy expression, very different from that of most monkeys. Their hands are very long, but have only four fingers, being adapted for hanging on to branches rather than for getting hold of small objects. It is said that when they have to cross a river the trees on the opposite banks of which do not approach near enough for a leap, several of them form a chain, one hanging by its tail from a lofty overhanging branch and seizing hold of the tail of the one below it, then gradually swinging themselves backward and forward till the lower one is able to seize hold of a branch on the opposite side. He then climbs up the tree, and, when sufficiently high, the first one lets go, and the swing either carries him across to a bough on the opposite side or he climbs up over his companions.

Closely allied to the last are the woolly monkeys, which have an equally well developed prehensile tail, but better proportioned limbs, and a thick woolly fur of a uniform gray or brownish color. They have well formed fingers and thumbs, both on the hands and feet, and are rather deliberate in their motions, and exceedingly tame and affectionate in captivity. They are great eaters, and are usually very fat. They are found only in the far interior of the Amazon valley, and, having a delicate constitution, seldom live long in Europe. These monkeys are not so fond of swinging themselves about by their tails as are the spider monkeys, and offer more opportunities of observing how completely this organ takes the place of a fifth hand. When walking about a house, or on the deck of a ship, the partially curled tail is carried in a horizontal position on the ground, and the moment it touches anything it twists round it and brings it forward, when, if eatable, it is at once appropriated; and when fastened up the animal will obtain any food that may be out of reach of its hands with the greatest facility, picking up small bits of biscuit, nuts, etc., much as an elephant does with the tip of his trunk.

We now come to a group of monkeys whose prehensile tail is of a less perfect character, since it is covered with hair to the tip, and is of no use to pick up objects. It can, however, curl round a branch, and serves to steady the animal while sitting or



feeding, but is never used to hang and swing by in the manner so common with the spider monkeys and their allies. These are rather small-sized animals, with round heads and with moderately long tails. They are very active and intelligent, their limbs are not so long as in the preceding group, and though they have five fingers on each hand and foot, the hands have weak and hardly opposable thumbs. Some species of these monkeys are often carried about by itinerant organ men, and are taught to walk erect and perform many amusing tricks. They form the genus *Cebus* of naturalists.

The remainder of the American monkeys have non-prehensile tails, like those of the monkeys of the Eastern hemisphere; but they consist of several distinct groups, and differ very much in appearance and habits. First we have the Sakis, which have a bushy tail and usually very long and thick hair, something like that of a bear. Sometimes the tail is very short, appearing like a rounded tuft of hair; many of the species have fine bushy whiskers, which meet under the chin, and appear as if they had been dressed and trimmed by a barber, and the head is often covered with thick curly hair, looking like a wig. Others, again, have the face quite red, and one has the head nearly bald, a most remarkable peculiarity among monkeys. This latter species was met with by Mr. Bates on the Upper Amazon, and he describes the face as being of a vivid scarlet, the body clothed from neck to tail with very long, straight, and shining white hair, while the head was nearly bald, owing to the very short crop of thin gray hairs. As a finish to their striking physiognomy these monkeys have bushy whiskers of a sandy color meeting under the chin, and yellowish gray eyes. The color of the face is so vivid that it looks as if covered with a thick coat of bright scarlet paint. These creatures are very delicate, and have never reached Europe alive, although several of the allied forms have lived some time in our Zoological Gardens.

An allied group consists of the elegant squirrel monkeys, with long, straight, hairy tails, and often adorned with pretty variegated colors. They are usually small animals; some have the face marked with black and white, others have curious whiskers, and their nails are rather sharp and claw like. They have large round heads, and their fur is more glossy and smooth than in most other American monkeys, so that they more resemble some of the smaller monkeys of Africa. These little creatures are very active, running about the trees like squirrels, and feeding largely on insects as well as on fruit.

Closely allied to these are the small group of night monkeys, which have large eyes, and a round face surrounded by a kind of ruff of whitish fur, so as to give it an owl like appearance, whence they are sometimes called owl-faced monkeys. They are covered with soft gray fur, like that of a rabbit, and sleep all day long concealed in hollow trees. The face is also marked with white patches and stripes, giving it a rather carnivorous or cat like aspect, which, perhaps, serves as a protection, by causing the defenseless creature to be taken for an arboreal tiger cat or some such beast of prey.

This finishes the series of such of the American monkeys as have a larger number of teeth than those of the Old World. But there is another group, the Marmosets, which have the same number of teeth as Eastern monkeys, but differently distributed in the jaws, a premolar being substituted for a molar tooth. In other particulars they resemble the rest of the American monkeys. They are very small and delicate creatures some having the body only seven inches long. The thumb of the hands is [1] not opposable, and instead of nails they have sharp compressed claws. These diminutive monkeys have long, non-prehensile tails, and they have a silky fur often of varied and beautiful colors. Some are striped with gray and white, or are of rich brown or golden brown tints, varied by having the head or shoulders white or black, while in many there are crests, frills, manes, or long ear tufts, adding greatly to their variety and beauty. These little animals are timid and restless; their motions are more like those of a squirrel than a monkey. Their sharp claws enable them to run quickly along the branches, but they seldom leap from bough to bough like the larger monkeys. They live on fruits and insects, but are much afraid of wasps, which they are said to recognize even in a picture.

[Transcribers note 1: Changed from '... it not opposable', ...]

This completes our sketch of the American monkeys, and we see that, although they possess no such remarkable forms as the gorilla or the baboons, yet they exhibit a wonderful diversity of external characters, considering that all seem equally adapted to a purely arboreal life. In the howlers we have a specially developed voice organ, which is altogether peculiar; in the spider monkeys we find the adaptation to active motion among the topmost branches of the forest trees carried to an extreme point of development; while the singular nocturnal monkeys, the active squirrel monkeys, and the exquisite little marmosets, show how distinct are the forms under which the same general type, may be exhibited, and in how many varied ways existence may be sustained under almost identical conditions.

## LEMURS.

In the general term, monkeys, considered as equivalent to the order Primates, or the Quadrumana of naturalists, we have to include another sub-type, that of the Lemurs. These animals are of a lower grade than the true monkeys, from which they differ in so many points of structure that they are considered to form a distinct sub-order, or, by some naturalists, even a separate order. They have usually a much larger head and more pointed muzzle than monkeys; they vary considerably in the number, form, and arrangement of the teeth; their thumbs are always well developed, but their fingers vary much in size and length; their tails are usually long, but several species have no tail whatever, and they are clothed with a more or less woolly fur, often prettily variegated with white and black. They inhabit the deep forests of Africa, Madagascar, and Southern Asia, and are more sluggish in their movements than true monkeys, most of them being of nocturnal and crepuscular habits. They feed largely on insects, eating also fruits and the eggs or young of birds.

The most curious species are--the slow lemurs of South India, small tailless nocturnal animals, somewhat resembling sloths in appearance, and almost as deliberate in their movements, except when in the act of seizing their insect prey; the Tarsier, or specter lemur, of the Malay islands, a small, long tailed nocturnal lemur, remarkable for the curious development of the hind feet, which have two of the toes very short, and with sharp claws, while the others have nails, the third toe being exceedingly long and slender, though the thumb is very large, giving the feet a very irregular and *outré* appearance; and, lastly, the Aye-aye, of Madagascar, the most remarkable of all. This animal has very large ears and a squirrel like tail, with long spreading hair. It has large curved incisor teeth, which add to its squirrel like appearance, and caused the early naturalists to class it among the rodents. But its most remarkable character is found in its fore feet or hands, the fingers of which are all very long and armed with sharp curved claws, but one of them, the second, is wonderfully slender, being not half the thickness of the others. This curious combination of characters shows that the aye-aye is a very specialized form--that is, one whose organization has been slowly modified to fit it for a peculiar mode of life. From information received from its native country, and from a profound study of its organization, Professor Owen believes that it is adapted for the one purpose of feeding on small wood-boring insects. Its large feet and sharp claws enable it to cling firmly to the branches of trees in almost any position; by means of its large delicate ears it listens for the sound of the insect gnawing within the branch, and is thus able to fix its exact position; with its powerful curved gnawing teeth it rapidly cuts away the bark and wood till it exposes the burrow of the insect, most probably the soft larva of some beetle, and then comes into play the extraordinary long wire-like finger, which enters the small cylindrical burrow, and with the sharp bent claw hooks out the grub. Here we have a most complex adaptation of different parts and organs, all converging to one special end, that end being the same as is reached by a group of birds, the woodpeckers, in a different way; and it is a most interesting fact that, although woodpeckers abound in all the great continents, and are especially common in the tropical forests of Asia, Africa, and America, they are quite absent from Madagascar. We may, therefore, consider that the aye-aye really occupies the same place in nature in the forests of this tropical island, as do the woodpeckers in other parts of the world.

### DISTRIBUTION, AFFINITIES, AND ZOOLOGICAL RANK OF MONKEYS.

Having thus sketched an outline of the monkey tribe as regards their more prominent external characters and habits, we must say a few words on their general relations as a distinct order of mammalia. No other group so extensive and so varied as this, is so exclusively tropical in its distribution, a circumstance no doubt due to the fact that monkeys depend so largely on fruit and insects for their subsistence. A very few species extend into the warmer parts of the temperate zones, their extreme limits in the northern hemisphere being Gibraltar, the Western Himalayas at 11,000 feet elevation, East Thibet, and Japan. In America they are found in Mexico, but do not appear to pass beyond the tropic. In the Southern hemisphere they are limited by the extent of the forests in South Brazil, which reach about 30° south latitude. In the East, owing to their entire absence from Australia, they do not reach the tropic; but in Africa, some baboons range to the southern extremity of the continent.

But this extreme restriction of the order to almost tropical lands is only recent. Directly we go back to the Pliocene period of geology, we find the remains of monkeys in France, and even in England. In the earlier Miocene, several kinds, some of large size, lived in France, Germany, and Greece, all more or less closely allied to living forms of Asia and Africa. About the same period monkeys of the South American type inhabited the United States. In the remote Eocene period the same temperate lands were inhabited by lemurs in the East, and by curious animals believed to be intermediate between lemurs and marmosets in the West. We know

from a variety of other evidence that throughout these vast periods a mild and almost sub-tropical climate extended over all Central Europe and parts of North America, while one of a temperate character prevailed as far north as the Arctic circle. The monkey tribe then enjoyed a far greater range over the earth, and perhaps filled a more important place in nature than it does now. Its restriction to the comparatively narrow limits of the tropics is no doubt mainly due to the great alteration of climate which occurred at the close of the Tertiary period, but it may have been aided by the continuous development of varied forms of mammalian life better fitted for the contrasted seasons and deciduous vegetation of the north temperate regions. The more extensive area formerly inhabited by the monkey tribe, would have favored their development into a number of divergent forms, in distant regions, and adapted to distinct modes of life. As these retreated southward and became concentrated in a more limited area, such as were able to maintain themselves became mingled together as we now find them, the ancient and lowly marmosets and lemurs subsisting side by side with the more recent and more highly developed howlers and anthropoid apes.

Throughout the long ages of the Tertiary period monkeys must have been very abundant and very varied, yet it is but rarely that their fossil remains are found. This, however, is not difficult to explain. The deposits in which mammalian remains most abound are those formed in lakes or in caverns. In the former the bodies of large numbers of terrestrial animals were annually deposited, owing to their having been caught by floods in the tributary streams, swallowed up in marginal bogs or quicksands, or drowned by the giving way of ice. Caverns were the haunts of hyenas, tigers, bears, and other beasts of prey, which dragged into them the bodies of their victims, and left many of their bones to become embedded in stalagmite or in the muddy deposit left by floods, while herbivorous animals were often carried into them by these floods, or by falling down the swallow-holes which often open into caverns from above. But, owing to their arboreal habits, monkeys were to a great extent freed from all these dangers. Whether devoured by beasts or birds of prey, or dying a natural death, their bones would usually be left on dry land, where they would slowly decay under atmospheric influences. Only under very exceptional circumstances would they become embedded in aqueous deposits; and instead of being surprised at their rarity we should rather wonder that so many have been discovered in a fossil state.

Monkeys, as a whole, form a very isolated group, having no near relations to any other mammalia. This is undoubtedly an indication of great antiquity. The peculiar type which has since reached so high a development must have branched off the great mammalian stock at a very remote epoch, certainly far back in the Secondary period, since in the Eocene we find lemurs and lemurine monkeys already specialized. At this remoter period they were probably not separable from the insectivora, or (perhaps) from the ancestral marsupials. Even now we have one living form, the curious Galeopithecus or flying lemur, which has only recently been separated from the lemurs, with which it was formerly united, to be classed as one of the insectivora; and it is only among the Opossums and some other marsupials that we again find hand-like feet with opposable thumbs, which are such a curious and constant feature of the monkey tribe.

This relationship to the lowest of the mammalian tribes seems inconsistent with the place usually accorded to these animals at the head of the entire mammalian series, and opens up the question whether this is a real superiority or whether it depends merely on the obvious relationship to ourselves. If we could suppose a being gifted with high intelligence, but with a form totally unlike that of man, to have visited the earth before man existed in order to study the various forms of animal life that were found there, we can hardly think he would have placed the monkey tribe so high as we do. He would observe that their whole organization was specially adapted to an arboreal life, and this specialization would be rather against their claiming the first rank among terrestrial creatures. Neither in size, nor strength, nor beauty, would they compare with many other forms, while in intelligence they would not surpass, even if they equaled, the horse or the beaver. The carnivora, as a whole, would certainly be held to surpass them in the exquisite perfection of their physical structure, while the flexible trunk of the elephant, combined with his vast strength and admirable sagacity, would probably gain for him the first rank in the animal creation.

But if this would have been a true estimate, the mere fact that the ape is our nearest relation does not necessarily oblige us to come to any other conclusion. Man is undoubtedly the most perfect of all animals, but he is so solely in respect of characters in which he differs from all the monkey tribe--the easily erect posture, the perfect freedom of the hands from all part in locomotion, the large size and complete opposability of the thumb, and the well developed brain, which enables him fully to utilize these combined physical advantages. The monkeys have none of these; and without them the amount of resemblance they have to us is no advantage, and confers no rank. We are biased by the too exclusive consideration of the man-like

apes. If these did not exist the remaining monkeys could not be thereby deteriorated as to their organization or lowered in their zoological position, but it is doubtful if we should then class them so high as we now do. We might then dwell more on their resemblances to lower types--to rodents, to insectivora, and to marsupials, and should hardly rank the hideous baboon above the graceful leopard or stately stag. The true conclusion appears to be, that the combination of external characters and internal structure which exists in the monkeys, is that which, when greatly improved, refined, and beautified, was best calculated to become the perfect instrument of the human intellect and to aid in the development of man's higher nature; while, on the other hand, in the rude, inharmonious, and undeveloped state which it has reached in the quadrumana, it is by no means worthy of the highest place, or can be held to exhibit the most perfect development of existing animal life.--*Contemporary Review*.

---

[JOURNAL OF THE SOCIETY OF ARTS.]

## **SILK-PRODUCING BOMBYCES AND OTHER LEPIDOPTERA REARED IN 1881.**

**By ALFRED WAILLY, Membre Lauréat de la Société  
d'Acclimatation de France.**

By referring to my reports for the years 1879 and 1880, which appeared in the *Journal of the Society of Arts*, February 13 and March 5, 1880, February 25 and March 4, 1881, it will be seen that the bad weather prevented the successful rearing in the open air of most species of silk-producing larvæ. In 1881, the weather was extremely favorable up to the end of July, but the incessant and heavy rains of the month of August and beginning of September, proved fatal to most of the larvæ when they were in their last stages. However, in spite of my many difficulties, I had the satisfaction of seeing them to their last stage. Larvæ of all the silk-producing bombyces were preserved in their different stages, and can be seen in the Bethnal-green Museum. In July, when the weather was magnificent, the little trees in my garden were literally covered with larvæ of more species than I ever had before, and two or three more weeks of fair weather would have given me a good crop of cocoons, instead of which I only obtained a very small number. The sparrows, as usual, also destroyed a quantity of worms, in spite of wire or fish-netting placed over some of the trees.

On the trees were to be seen--*Attacus cynthia* (the Ailantus silkworm), the rearing of which was, as usual, most successful; *Samia cecropia* and *Samia gloveri*, from America; also hybrids of *Gloveri cecropia* and *Cecropia gloveri*; *Samia promethea* and *Telea polyphemus*; *Attacus pernyi*, and a new hybrid, which I obtained this last season by the crossing of Pernyi with Royle. For the first time I reared *Actias selene*, from India, on a nut-tree in the garden, and *Attacus atlas*, on the ailantus. The *Selene* larvæ reached their fifth and last stage. The *Atlas* larvæ only reached the third stage, and were destroyed by the heavy rains; only two remained on the tree till about the 8th or 9th of September, when they had to be removed. I shall now reproduce the notes I took on some of the various species I reared.

*Actias Selene*.--With sixty cocoons I only obtained one pairing. The moths emerged from the beginning of March till the 13th of August, at intervals of some duration, or in batches of males or females. I obtained a pairing of *Selene* on the 30th of June, 1881, and the worms commenced to hatch on the 13th of July. The larvæ in first stage are of a fine brown-red, with a broad black band in the middle of the body. The second stage commenced on the 20th of July; larvæ, of a lighter reddish color, without the black band; tubercles black. Third stage commenced on the 28th of July; larvæ green; the first four tubercles yellow, with a black ring at the base; other tubercles, orange yellow. Fourth stage commenced on the 6th of August; larvæ green; first four tubercles golden-yellow, the others orange-red. Fifth stage commenced on the 19th of August; first four tubercles yellow, with a black ring at the base; other tubercles yellow, slightly tinged with orange-red; lateral band brown and greenish yellow; head and forelegs dark-brown. As stated before, the larvæ were reared on a nut-tree in the garden, till the last stage. *Selene* feeds on various trees--walnut, wild cherry, wild pear, etc. In Ceylon (at Kandy), it is found on the wild olive tree. As far as I am informed by correspondents in Ceylon, this species is not found--or is seldom found--on the coasts, but *Attacus atlas* and *Mylitta* are commonly found there.

*Attacus (antheroea) roylei* (with sixty cocoons); three pairings only were obtained, and this species I found the most difficult to pair in captivity. Two moths emerged on the 5th of March, a male and a female, and a pairing was obtained; but the weather being then too cold, the ova were not fertile, the female moth, after laying about two hundred eggs, lived till the 22d of March, which is a very long time; this was owing to the low temperature. The moths emerged afterward from the 8th of April till the

25th of June. A pairing took place on the 2d of June, and another on the 6th of June.

Roylei (the Himalaya oak silkworm) is very closely allied to Pernyi, the Chinese oak silkworm; the Roylei moths are of a lighter color, but the larvæ of both species can hardly be distinguished from one another. The principal difference between the two species is in the cocoon. The Roylei cocoon is within a very large and tough envelope, while that of Pernyi has no outer envelope at all. The larvæ of Roylei I reared did not thrive, and the small number I had only went to the fourth stage, owing to several causes. I bred them under glass, in a green-house. A certain number of the larvæ were unable to cut the shell of the egg.

Here are a few notes I find in my book: Ova of Roylei commenced to hatch on the 29th of June; second stage commenced on the 9th of July. The larvæ in the first two stages seemed to me similar to those of Pernyi, as far as I could see. In second stage, the tubercles were of a brilliant orange-red; on anal segment, blue dot on each side. Third stage, four rows of orange-yellow tubercles, two blue dots on anal segment, brilliant gold metallic spots at the base of the tubercles on the back, and silver metallic spots at the base of the tubercles on the sides. No further notes taken.

One of my correspondents in Vienna (Austria) obtained a remarkable success in the rearing of Roylei. From the twenty-five eggs he had twenty-three larvæ hatched, which produced twenty-three fine cocoons. The same correspondent, with thirty-five eggs of *Samia gloveri*, obtained twenty cocoons. My other correspondents did not obtain any success in rearing these two species, as far as I know.

*Hybrid Roylei-Pernyi.*--I have said that it is extremely difficult to obtain the pairing of Roylei moths in captivity. But the male Pernyi paired readily with the female Roylei. I obtained six such pairings, and a large quantity of fertile ova. The pairings of Roylei (female) with Pernyi (male) took place as follows: two on the 21st of May, one on the 3d of June, two on the 4th of June, and one on the 6th.

The larvæ of this new hybrid, *Roylei-Pernyi*, contrary to what might have been expected, were much easier to rear than those of Roylei, and the cocoons obtained are far superior to those of Roylei, in size, weight, and richness of silk. The cocoon of my new hybrid has, like Roylei, an envelope, but there is no space between this envelope and the true cocoon inside. Therefore, this time, the crossing of two different species (but, it must be added, two very closely allied species) has produced a hybrid very superior, at least to one of the types, that of Roylei. The cocoons of the hybrid *Roylei-Pernyi* seem to me larger and heavier than any Pernyi cocoons I have as yet seen.

The larvæ of this new hybrid have been successfully reared in France, in Germany, in Austria, and in the United States of North America. The cocoons obtained by Herr L. Huessman, one of my German correspondents, are remarkable for their size and beauty. The silk is silvery white.

I have seventeen cocoons of this hybrid species, which number may be sufficient for its reproduction. But the question arises, "Will the moths obtained from these cocoons be susceptible of reproduction?"

In my report on Lepidoptera for the year 1879, I stated, with respect to hybrids and degeneracy, that hybrids had been obtained by the crossing of *Attacus pernyi* and *Attacus yama-mai*, but that, although the moths (some of which may be seen in the Bethnal-green Museum) are large and apparently perfect in every respect, yet these hybrids could not be reproduced. It must be stated that these two species differ essentially in one particular point. *Yama-mai* hibernates in the *ovum* state, while Pernyi hibernates in the *pupa* state. The hybrids hibernated in the *pupa* state. Roylei, as Pernyi, hibernates in the *pupa* state.

In the November number, 1881, of "The Entomologist," Mr. W.F. Kirby, of the British Museum, wrote an article having for its title, "Hermaphrodite-hybrid Sphingidæ," in which, referring to hybrids of *Smerinthus ocellatus* and *populi*, he says that hermaphroditism is the usual character of such hybrids.

I extract the following passage from his article: "I was under the impression that hermaphroditism was the usual character of these hybrids; and it has suggested itself to my mind as a possibility, which I have not, at present, sufficient data either to prove or to disprove, that the sterility of hybrids in general (still a somewhat obscure subject) may perhaps be partly due to hybridism having a tendency to produce hermaphroditism."

Now, will the moths of new hybrid Roylei pernyi (which I expect will emerge in May or June, 1882) have the same tendency to hermaphroditism as has been observed with the hybrids obtained by the crossing of *Smerinthus populi* with *Sm. ocellatus*? I do not think that such will be the case with the moths of the hybrid Roylei-pernyi, on account of the close relationship of Roylei with Pernyi, but nothing certain can be

known till the moths have emerged. Here are the few notes taken on the hybrid Roylei-pernyi: Ova commenced to hatch on the 12th of June; these were from the pairing which had taken place on the 21st of May. Larvæ, black, with long white hairs. Second stage commenced on the 21st of June. Larva, of a beautiful green; tubercles orange-yellow; head dark brown. Third stage commenced on the 1st of July; fourth stage on the 7th. Larva of same color in those stages; tubercles on the back, violet-blue or mauve; tubercles on the sides, blue. Fifth stage commenced on the 18th of July. Larva, with tubercles on back and sides, blue, or violet-blue. First cocoon commenced on the 10th of August. Want of time prevented me from taking fuller and more accurate notes.

*Attacus Atlas*.--For the first time, as stated before, I attempted the rearing of a small number of Atlas larvæ in the open air on the ailantus tree, but had to remove the last two remaining larvæ in September; the others had all disappeared in consequence of the heavy and incessant rains. These larvæ were from eggs sent to me by one of my German correspondents. The pairing of the moths had taken place on the 17th of July, and the eggs had commenced to hatch on the 4th of August.

I had about eighty cocoons of another and larger race of Atlas imported from the Province of Kumaon, but only eight moths emerged at intervals from the 31st of July to the 30th of September. Not only did the moths emerge too late in the season, but there never was a chance of obtaining a pairing. In my report on Indian silkworms, published in the November number of the "Bulletin de la Societe d'Acclimatation," for the year 1881, compiled from the work of Mr. J. Geoghegan, I reproduce the first appendix of Captain Thomas Hutton to Mr. Geoghegan's work, in which are given the names of all the Indian silkworms known by him up to the year 1871.

Of *Attacus atlas*, Captain Hutton says: "It is common at 5,500 feet at Mussoorie, and in the Dehra Doon; it is also found in some of the deep warm glens of the outer hills. It is also common at Almorah, where the larva feeds almost exclusively upon the 'Kilmorah' bush or *Berberis asiatica*; while at Mussoorie it will not touch that plant, but feeds exclusively upon the large milky leaves of *Falconeria insignis*. The worm is, perhaps, more easily reared than any other of the wild bombycidæ."

I will now quote from letters received from one of my correspondents in Ceylon, a gentleman of great experience and knowledge in sericulture.

In a letter dated 24th August, 1881, my correspondent says: "The Atlas moth seems to be a near relation of the Cynthia, and would probably feed on the Ailantus. Here it feeds on the cinnamon and a great number of other trees of widely different species; but the tree on which I have kept it most successfully in a domestic state is the *Milnea roxburghiana*, a handsome tree, with dark-green ternate leaves, which keep fresh long after being detached from the tree. I do not think the cocoon can ever be reeled, as the thread usually breaks when it comes to the open end. I have tried to reel a great many Atlas cocoons, but always found the process too tedious and troublesome for practical use.

"The Mylitta (Tusser) is a more hardy species than the Atlas, and I have had no difficulty in domesticating it. Here it feeds on the cashew-nut tree, on the so-called almond of this country (*Terminalia catappa*), which is a large tree entirely different from the European almond, and on many other trees. Most of the trees whose leaves turn red when about to fall seem to suit it, but it is not confined to these. In the case of the Atlas moth, I discovered one thing which may be well worth knowing, and that was, that with cocoons brought to the seaside after the larvæ had been reared in the Central Provinces, in a temperature ten or twelve degrees colder, the moths emerged in from ten to twenty days after the formation of the cocoon. The duration of the pupa stage in this, and probably in other species, therefore, depends upon the temperature in which the larvæ have lived, as well as the degree of heat in which the cocoons are kept; and in transporting cocoons from India to Europe, I think it will be found that the moths are less liable to be prematurely forced out by the heat of the Red Sea when the larvæ have been reared in a warm climate than when they have been reared in a cold one.

"I do not agree with the opinion expressed in one of your reports, that the short duration of the larva stage, caused by a high temperature, has the effect of diminishing the size of the cocoons, because the Atlas and Tusser cocoons produced at the sea-level here are quite as large as those found in the Central Provinces at elevations of three thousand feet or more. According to the treatise on the "Silk Manufacture," in "Lardner's Cyclopaedia," the Chinese are of opinion that one drachm of mulberry silkworms' eggs will produce 25 ounces of silk if the caterpillars attain maturity within twenty-five days; 20 ounces if the commencement of the cocoons be delayed until the twenty-eighth day; and only 10 ounces if it be delayed until between the thirtieth and fortieth day. If this is correct, a short-lived larva stage must, instead of causing small cocoons, produce just the contrary effect."

In another letter, dated November 25, 1881, my correspondent says: "I am sorry that

you have not had better success in the rearing of your larvæ, but you should not despair. It is possible that the choice of an improper food-plant may have as much to do with failures as the coldness and dampness of the English climate. I lost many thousands of Atlas caterpillars before I found out the proper tree to keep them on in a domesticated state; and when I did attain partial success, I could not keep them for more than one generation, till I found the *Milnea roxburghiana* to be their proper food plant. I do not know the proper food-plant of the Mylitta (Tusser), but I have succeeded very well with it, as it is a more hardy species than the Atlas. Though a Bombyx be polyphagous in a state of nature, yet I think most species have a tree proper to themselves, on which they are more at home than on any other plant. I should like, if you could find out from some your correspondents in India, on what species of tree Mylitta cocoons are found in the largest numbers, and what is about the greatest number found on a single tree. The Mylitta is common enough here, but there does not seem to be any kind of tree here on which the cocoons are to be found in greater numbers than twos and threes; and there must be some tree in India on which the cocoons are to be found in much greater plenty, because they could not otherwise be collected in sufficient quantity for manufacturing purposes. The Atlas is here found on twenty or more different kinds of trees, but a hundred or a hundred and fifty cocoons or larvæ may be found on a single tree of *Milnea roxburghiana*, while they are to be found only singly, or in twos and threes, on any other tree that I know of. The Atlas and Mylitta seem to be respectively the Indian relations of the Cynthia and Pernyi. It is, therefore, probable that the Ailantus would be the most suitable European tree for the Atlas, and the oak for the Mylitta."

*Attacus mylitta* (*Antheræa paphia*).--I did not receive a single cocoon of this species for the season 1881. My stock consisted of seven cocoons, from the lot received from Calcutta at the end of February, 1880. Five were female, and two male cocoons; one of the latter died, thus reducing the number to six. The moths emerged as follows: One female on the 21st of June, one female on the 26th, one female on the 28th, one female on the 1st of July, and one male on the 3d of August; the latter emerging thirty-four days too late to be of any use for rearing purposes. The last female moth emerged, I think, about the end of September. These cocoons had hibernated twice, as has been the case with other Indian species. I had Indian cocoons which hibernated even three times.

*Attacus cynthia*, from the province of Kumaon.--With the Atlas cocoons, a large quantity of Cynthia cocoons were collected in the province of Kumaon. Both species had, no doubt, fed on the same trees; as the Cynthia, like the Atlas cocoons, were all inclosed in leaves of the *Berberis vulgaris*, which shows that Cynthia is also a polyphagous species. It is already known that it feeds on several species of trees, besides the ailantus, such as the laburnum, lilac, cherry, and, I think, also on the castor-oil plant; the common barberry has, therefore, to be added to the above food plants.

These Kumaon Cynthia cocoons were somewhat smaller and much darker in color than those of the acclimatized Cynthia reared on the ailantus. The moths of this wild Indian Cynthia were also of a richer color than those of the cultivated species in Europe.

During the summer 1881, I saw cocoons of my own Cynthia race obtained from worms which had been reared on the laburnum tree. These cocoons were, as far as I can remember, of a yellowish or saffron color; which I had never seen before. This difference in the color of the cocoon was very likely produced by the change of food, although it has been stated, and I think it may be quite correct, that with many species of native lepidoptera the change of food-plants does not produce any difference of color in the insects obtained. With respect to the Cynthia worms reared on the laburnum instead of the ailantus, it may be that the moths, which will emerge from the yellow cocoons, will be similar to those obtained from cocoons spun by worms bred on the ailantus, and that the only difference will be in the color of the cocoons.

The Kumaon Cynthia cocoons, as I found it to be the case with Indian species introduced for the first time into Europe, did not produce moths at the same time, nor as regularly as the acclimatized species. The moths emerged as follows: One female on the 22d of July; one female on the 25th; one male on the 3d August; one female on the 19th; one male on the 28th of August; one male on the 2d September; one female on the 3d. A pairing was obtained with the latter two. Two males emerged on the 4th of September; one male on the 6th; one male and one female on the 22d; one female on the 23d; and one female on the 25th of September. Five cocoons, which did not produce any moths, contain pupæ, which are still in perfect condition; and the moths will no doubt emerge next summer (1882). As seen in my note, a pairing of this wild Indian Cynthia took place; this was from the evening of the 4th to the 5th of September. The eggs laid by the female moth were deposited in a most curious way, in smaller or larger quantities, but all forming perfect triangles. These eggs I gave to a florist who has been very successful in the rearing of silk-

producing and other larvæ; telling him to rear the Cynthia on lilacs grown in pots and placed in a hot-house, which was done. The worms, which hatched in a few days, as they were placed in a hot-house, thrived wonderfully well, and I might say they thrived too well, as they grew so fast and became so voracious that the growth of the lilac trees could not keep pace with the growth of the worms. These, at the fourth stage, became so large that the foliage was entirely devoured, and, of course, the consequence was that all the worms were starved. I only heard of the result of that experiment long after the death of the larvæ; otherwise I should have suggested the use of another plant after the destruction of the foliage of the lilacs; the privet (*Ligustrum vulgare*) might have been tried, and success obtained with it.

Of such species as *Attacus pyri*, of Central Europe, and *Attacus pernyi*, the North Chinese oak silkworm, which I have mentioned in my previous reports, and bred every season for several years, I shall only say that I never could rear Pyri in the open air in London, up to the formation of the cocoon. As to Pernyi, I had, in 1881, an immense quantity of splendid moths, from which I obtained the largest quantity of ova I ever had of this species. I had many thousands of fertile ova of Pernyi, which I was unable to distribute. Many schoolboys reared Pernyi worms, but with what success I do not yet know. The number of fertile ova obtained from Pyri moths was also more considerable than in former years, which was due partly to the good quality of the pupæ, and partly to the very favorable weather in June, at the time the pairings of the moths took place.

Leaving these, I now come to the North American species.

*Telea polyphemus*.--As I have stated in former years, this is the best North American silkworm, producing a closed cocoon, somewhat smaller than that of Pernyi, but the silk seems as good as that of Pernyi.

The cocoons of Polyphemus I had in 1881 were smaller and inferior in quality to those I had before. Those received in 1878 and 1879 were considerably finer and larger than those which were sent in 1880 and 1881; besides, they were sent in much larger quantities. The cocoons received this year (1882) are finer than those of 1881, but yet they cannot be compared with those of 1878 and 1879.

With about sixty cocoons of *Telea polyphemus* I only obtained three pairings, which I attribute solely to the weakness of the moths, as the weather was all that could be desired for the pairings. The moths emerged from the 1st of June to the 20th of July. One male moth emerged on the 7th September. This latter was one from a small number of cocoons received from Alabama; the other cocoons of the same race had emerged at the same time as the cocoons from the Northern States. In the Northern States the species is single-brooded; in the Southern States it is double-brooded.

The larvæ of Polyphemus can be bred in the open air in England, almost as easily as those of Pernyi, and even Cynthia; they will pass through their five stages and spin their cocoons on the trees, unless the weather should be unexceptionally cold and wet, as was the case during the month of August, 1881, when the larvæ had reached their full size; they were reared this year on the nut-tree, and some on the oak. The species is extremely polyphagous, and will feed well on oak, birch, chestnut, beech, willow, nut, etc.

The moth of Polyphemus is very beautiful, and, as in some other species, varies in its shades of color. The larva is of a transparent green, of extreme beauty; the head is light brown; without any black dots, as in Pernyi; the spines are pink, and at the base of each of them there is a brilliant metallic spot. When the sun shines on them the larvæ seem to be covered with diamonds. These metallic spots at the base of the spines are also seen on Pernyi, Yama mai, Mylitta, and other species of the genus *Antheræa*, all having a closed cocoon, but none of these have so many as Polyphemus.

The cocoons of the species of the genus *Actias* are closed, but the larvæ have not the metallic spots of the species of the genus *Antheræa*.

*Samia Gloveri*.--Three North American silk-producing bombyces, very closely allied, have been mentioned in my previous reports; they are; *Samia ceanothi*, from California; *Samia gloveri*, from Utah and Arizona; and *Samia cecropia*, commonly found in most of the Northern States--the latter is the best and largest silk producer. Crossings of these species took places in 1880, and, as I stated before, the ova obtained from a long pairing between a Ceanothi female with a Gloveri male, were the only ones which were fertile. The Gloveri cocoons received in 1880 were of a very inferior quality, and produced moths from which no pairings could be obtained, although some crossings took place. In 1881, the Gloveri cocoons, on the contrary, produced fine, healthy moths; yet only five pairings could be obtained, with about one hundred cocoons. Besides these five pairings, a quantity of fertile ova were obtained by the crossings of *S. gloveri* (female) with *S. cecropia* (male), and *Cecropia* (female) with Gloveri (male). No success, so far as I know, was obtained with the



rearing of the hybrid larvæ; the rearings of the larvæ of pure Gloveri were also, I think, a failure, only one correspondent having been successful; but some correspondents have not yet made the result of their experiments known to me. The larvæ of *Samia cecropia*, *S. gloveri*, and *S. ceanothi*, are very much alike; and hardly any difference can be observed in the first two stages. In the third and fourth stages, the larvæ of *S. cecropia* and *S. gloveri* are also nearly alike; the principal difference between these two species and *S. cecropia* being that the tubercles on the back are of a uniform color--orange-red, or yellow--while on *Cecropia* the first four dorsal tubercles are red, and the rest yellow. The tubercles on the sides are blue on the three species.

The larvæ of the hybrids *Gloveri-cecropia* were, as far as I could observe, like those of *Cecropia*, but I noticed some with six red tubercles on the back instead of four, as on *Cecropia*. They were reared on plum, apple, and *Salix caprea*; in the open air.

The larvæ of *Samia gloveri* were reared, during the first four stages on a wild plum-tree, then on *Salix caprea*, and I reproduce the notes taken on this species, which I bred this year (1881) for the first time.

Gloveri moths emerged from the 15th of May to the end of June; five pairings took place as follows: 1st, 4th, 9th, 24th, and 26th of June. First stage--larvæ quite black. Second stage--larvæ orange, with black spines. Third stage--dorsal spines, orange-red; spines on sides blue. Fourth stage--dorsal spines, orange or yellow, spines on the sides blue; body light blue on the back, and greenish yellow on the sides; head, green; legs, yellow. Fifth and sixth stage--larvæ nearly the same; tubercles on the back yellow, the first four having a black ring at the base; side tubercles ivory-white, with a dark-blue base.

The above-mentioned American species, like most other silk-producing bombyces, were bred in the open air; but besides these, I reared three other species of American bombyces in the house, under glass, and with the greatest success. These are: *Hyperchiria io*, a beautiful species mentioned in my report for the year 1879; *Orgyia leucostigma*, from ova received on December 29, 1880, from Madison, Wis., which hatched on the 27th of May, 1881.

The third American species reared under glass is the following very interesting bombyx: *Ceratocampa (Eacles) imperialis*. The pupæ of this species are rough, and armed with small, sharp points at all the segments; the last segment having a thick, straight, and bifid tail. The moths, which measure from four to about six inches in expanse of wings, are bright yellow, with large patches and round spots of reddish-brown, with a purple gloss; besides these patches and round spots, the wings are covered with small dark dots. The male moth is much more blotched than the female, and although of a smaller size, is much more showy than the female.

With twenty-four pupæ of *Imperialis* I obtained nineteen moths from the 21st of June to the 19th of July; five pupæ died. Two pairings took place; the first from the evening of the 13th to the morning of the 14th; the second from the evening of the 15th to the morning of the 16th of July.

The ova, which are about the size of those of Yama-mai, Pernyi, or Mylitta, are rather flat and concave on one side, of an amber-yellow color and transparent, like those of sphingidæ. When the larvæ have absorbed the yellow liquid in the egg, and are fully developed; they can be seen through the shell of the egg, which is white or colorless when the larva has come out.

The larvæ of *Imperialis*, which have six stages, commenced to hatch on the 31st of July; the second stage commenced on the 7th of August; the third, on the 17th; the fourth, on the 29th of August; the fifth, on the 18th of September; and the sixth, on the 1st of October. The larvæ commenced to pupate on 13th of October.

The larvæ of this curious species vary considerably in color. Some are of a yellowish color, others are brown and tawny, others are black or nearly black. My correspondent in Georgia, who bred this species the same season as I did, in 1881, had some of the larvæ that were green. In all the stages the larvæ have five conspicuous spines or horns; two on the third segment, two on the fourth, and one on the last segment but one; this is taking the head as the first segment with regard to the first four spines. These spines are rough and covered with sharp points all round, and their extremities are fork-like. In the first three stages they are horny; in the last three stages these spines are fleshy, and much shorter in proportion than they are in the first three stages. The color of the spines in the last three stages is coral-red, yellowish, or black. In the fifth and sixth stages the spine on the last segment but one is very short.

Here are a few and short notes from my book:

1st stage. Larvæ, about one-third of an inch; head, brown, shiny, and globulous.

2d stage. Larvæ, dark-brown, almost black; spines, white at the base, and black at the extremities; head shiny and light brown.

3d stage. Larve, fine black; head black; white hairs on the back; spines, whitish, buff, or yellowish at the base, and black at the extremities; other larvæ of a brown color.

4th stage. Larvæ, black granulated with white; long white hairs; horns, brown-orange with white tips; on each segment two brown spots. Spiracles well marked with outer circle, brown, then black; white and black dot in the center. Anal segment with brown ribs, the intervals black with white dots; head shining, black with two brown bands on the face, forming a triangle. Other larvæ in fourth stage, velvety black, with coral-red spines; others with black spines.

5th stage. Larvæ, entirely black, with showy eye-like spiracles, polished black head; other larvæ having the head brown and black. Larvæ covered with long white hair; spines black or red. No difference noticed between the fifth and sixth stages.

One larva on fourth stage was different from all others, and was described at the British Museum by Mr. W. F. Kirby as follows: "Larva reddish-brown, sparingly clothed with long slender white hairs, with four reddish stripes on the face, two rows of red spots on the back, spiracles surrounded with yellow, black and red rings; legs red, prolegs black, spotted with red. On segments three and four are four long coral-red fleshy-branched spines, two on each segment, below which, on each side, are two rudimentary ones just behind the head; in front of segment two are four similar rudimentary orange spines or tubercles; last segment black, strongly granulated and edges triangularly above and at the sides, with coral-red; several short rudimentary fleshy spines rising from the red portion; the last segment but one is reddish above, with a short red spine in the middle, and the one before it has a long coral-red spine in the middle similar to those of segments three and four, but shorter"

As soon as my *Imperialis* larvæ had hatched, I gave them various kinds of foliage, plane-tree, oak, pine, sallow, etc. At first they did not touch any kind of foliage, or they did not seem to touch any; and I was afraid I should be unable to rear them; but on the second or third day of their existence, they made up their minds and decided upon eating the foliage of some of the European trees I had offered them. They attacked oak, sallow, and pine, but did not touch the plane-tree leaves. In America, the larvæ of *Imperialis* feed on button-wood, which is the American plane-tree (*Platanus occidentalis*), yet they did not take to *Platanus orientalis*. After a little time I reduced the foliage to oak and sallow branches, and ultimately gave them the sallow (*Salix caprea*) only, on which they thrived very well. I was pleased with this success; as I had previously read in a volume of the "Naturalist's Library" a description of *Ceratocampa imperialis*, which ends as follows: "The caterpillars are not common, and are the most difficult to bring to perfection in confinement, as they will not eat in that situation; and, even if they change into a chrysalis, they die afterward."

Before I finish with *C. imperialis*, I must mention a peculiar fact. During the first stage, and, I think, also during the second, several larvæ disappeared without leaving any traces. I also saw two smaller larvæ held tight by the hind claspers of two larger ones. The larvæ thus held and pressed were perfectly dead when I observed them, and I removed them. My impression then was that these larvae were carnivorous, not from this last fact alone, as I had previously observed it with larvæ of *Catocalæ* when they are too crowded, but from the fact that some had disappeared entirely from the glass under which they were confined. I began to reduce their numbers, and put six only under each glass, so as to be able to watch them better. Whether I had made a mistake or not previously to this I do not exactly know; but from this moment the larvae behaved in a most exemplary manner, especially when they became larger. They crawled over each other's backs without the least sign of spite or animosity, even when they were in sleep, in which case larvæ are generally very sensitive and irritable, all were of a most pacific nature. It is, therefore, with the greatest pleasure that, for want of sufficient evidence, I withdraw this serious charge of cannibalism which I first intended to bring against them.

From what has been said respecting the rearing of exotic silk-producing bombyces, especially tropical species, it must have been observed that several difficulties, standing in the way of success, have to be overcome. The moths of North American species emerge regularly enough during the months of May, June, or July, but Indian and other tropical species may emerge at any time of the year, if the weather is mild, as has been the case during this unusually mild winter of 1881-1882. From the end of December to the present time (March 14, 1882) moths of four species of Indian silk-producers, especially *Antheræa roylei* and *Actias selene*, have constantly emerged, but only one or two at a time. These moths emerged from cocoons received in December and January last.

It is only when these tropical species shall have been already reared in Europe that the emergence of the moths will be regular; then they will be single-brooded in

Northern or Central Europe, and some will very likely become double-brooded in Southern Europe. But when just imported the moths of these tropical species will always be uncertain and irregular in their emergence; hence the importance of having a sufficient number of cocoons so as to meet this difficulty, i.e., the loss of the moths that emerge prematurely or irregularly.

Before I conclude, I shall repeat what I already stated in a previous report, that the sending of live cocoons and pupæ from India and other distant countries to Europe, can easily be done, so that they will arrive alive and in good condition, if care be taken that the boxes containing these live cocoons and pupæ should not be left in the sun or near a fire (which has been the case before), and that they should at once be put in a cool place or in the ice-room of the steamer. The cocoons and pupæ should be sent from October to March or April, according to distance, and it is most important to write on the cases, "Living silkworm cocoons or pupæ, the case to be placed in the ice room."

By taking this simple precaution, live cocoons and pupæ, when newly formed, can be safely sent from very distant countries of Europe.

To continue these interesting and useful studies, I shall always be glad to buy any number of live cocoons, or exchange them for other species, if preferable.

ALFRED WAILLY.

110 Clapham Road, London, S.W.

---

## MOSQUITO OIL.

A correspondent from Sheepshead Bay, a place celebrated for the size of its mosquitoes and the number of its amateur fishermen, recommends the following as a very good mixture for anointing the face and hands while fishing:

Oil of tar.	1 ounce.
Olive oil.	1 ounce.
Oil of pennyroyal.	$\frac{1}{2}$ ounce.
Spirit of camphor.	$\frac{1}{2}$ ounce.
Glycerine.	$\frac{1}{2}$ ounce.
Carbolic acid.	2 drachms.

Mix. Shake well before using.--*Drug. Circular.*

---

## THE CATHEDRAL OF BURGOS.

This most remarkable structure, in the province of the same name, adorns the city of Burgos, 130 miles north of Madrid. The corner stone was laid July 20, A.D. 1221, by Fernando III., and his Queen Beatrice, assisted by Archbishop Mauricio. The world is indebted to Mauricio for the selection of the site, and for the general idea and planning of what he intended should be, and in fact now is, the finest temple of worship in the world. This immense stone structure, embellished with airy columns, pointed arches, statues, inscriptions, delicate crestings, and flanked by two needles or aerial arrows, rises toward the heavens, a sublime invocation of Christian genius.

Illuminated by the morning sun it appears, at a certain distance, as if the pyramids were floating in space; further on is seen the marvelous dome of the transept, crowned with eight towers of chiseled lace-work, over the center of the church.

Public worship was held in a portion of the edifice nine years after the work was begun; from that time onward for three hundred years, various additional portions were completed. On March 4, 1539, the great transept, built fifty years previous, fell down; but was soon restored. August 16, 1642, at 6½ o'clock, P.M., a furious hurricane overthrew the eight little towers that form the exterior corner of the dome; but in two years they were replaced, namely July 19, 1644: the same night the great bells sounded an alarm of fire, the transept having in some way become ignited. The activity of the populace, however, prevented the loss of the edifice, which for a time was in great danger.

The first architect publicly mentioned in the archives of the edifice was the Master Enrique. He also directed the work of the Cathedral of Leon. He died July 10, 1277. The second architect was Juan Perez, who died in 1296, and was buried in the cloister, under the cathedral. He is believed to have been either the son or brother of the celebrated Master Pedro Perez, who designed the Cathedral of Toledo, and who died in 1299. The third architect of the Cathedral of Burgos was Pedro Sanchez, who directed the work in 1384; after him followed Juan Sanchez de Molina, Martin Fernandez, the three Colonias, Juan de Vallejo, Diego de Siloe, the elder Nicolas de

Vergara, Matienzo, Pieredonda, Gil, Regines, and others. It is worthy of note that a number of Moorish architects were employed on the work during the 14th and 15th centuries, such as Mohomad, Yunce, the Master Hali, the Master Mahomet de Aranda, the Master Yunza de Carrion, the Master Carpenter Brahen. Among the figure sculptors employed were Juan Sanchez de Fromesta, the Masters Gil and Copin, the famous Felipe de Vigardi, Juan de Lancre, Anton de Soto, Juan de Villareal, Pedro de Colindres, and many others. Our engraving is from a recent number of *La Ilustracion Espanola y Americana*.



THE CATHEDRAL OF BURGOS, SPAIN.--PHOTOGRAPH BY DE LAURENT.--  
DRAWING BY M. HEBERT.

---

## THE PANAMA CANAL.

By **MANUEL EISSLER, M.E., of San Francisco, Cal.**

### I.

#### HISTORICAL NOTES.

When Cortez, in the year 1530, made the observation that the two great oceans could be seen from the peaks of mountains, he, in those remote days, preoccupied himself with the question to cut through the Cordilleras.

Therefore, the idea of an interoceanic canal is by no means a modern one, as travelers and navigators observed that there was a great depression among the hills of the Isthmus of Panama. As Professor T.E. Nurse, of the U.S.N., says in his memoirs:

"This problem of interoceanic communication has been justly said to possess not only practical value, but historical grandeur. It clearly links itself back to the era of the conquest of Cortez, three and a half centuries." [1] It is a problem which has been left for our modern era to solve, but nevertheless its history is thereby rendered still more interesting, having needed so many centuries to bring it to an issue.

[Footnote 1: From Prof. Nurse's historical essay. See Survey of Nicaragua Canal, by Com. Lull.]

Spain, which acquired through her Columbus a new empire, lying near, as it was supposed, to the riches of Asia, could not be indifferent, from the moment of her discoveries, to the means of crossing these lands to yet richer ones beyond.

India, from the days of Alexander and of the geographers, Mela, Strabo, and Ptolemy, was the land of promise, the home of the spices, the inexhaustible fountain of wealth. The old routes of commerce thither had been closed one by one to the Christians; the overland trade had fallen into the hands of the Arabs; and at the fall of Constantinople, 1453, the commerce of the Black Sea and of the Bosphorus, the last of the old routes to the East, finally failed the Christian world. Yet even beyond the fame of the East, which tradition had brought down from Greek and Roman, much more had the crusaders kindled for Asia (Cathay) and its riches an ardor not easily suppressed in men's minds.

The error of the Spanish Admiral in supposing that the eastern shores of Asia extended 240 degrees east of Spain, or to the meridian of the modern San Diego, in California--this error, insisted on in his dispatches and adopted and continued by his followers, still further animated the earlier Spanish sovereigns and the men whom they sent into the New World to reach Asia by a short and easy route.

Nobody in Europe dreamt that Columbus had discovered a new continent, and when Balbao, in 1513, discovered the South Sea, then it was known that Asia lay beyond, and navigators directed their course there. On his deathbed, in 1506, Columbus still held to his delusion that he had reached Zipanga, Japan. In 1501 he was exploring the coast of Veragua, in Central America, still looking for the Ganges, and announcing his being informed on this coast of a sea which would bear ships to the mouth of that river, while about the same time the Cabots, under Henry VII., were taking possession of Newfoundland, believing it to be part of the island coast of China.

Although these were grave blunders in geography and in navigation, the discoveries really made in the rich tropical zones, the acquirement of a new world, and the rich products continually reaching Europe from it, for a time aroused Spain from her lethargy. The world opened east and west. The new routes poured their spices, silks, and drugs through new channels into all the Teutonic countries. The strong purposes of having near access to the East were deepened and perpetuated doubly strong, by the certainties before men's eyes of what had been attained.

Balbao, in 1513, gained from a height on the Isthmus of Panama the first proof of its separation from Asia; and Magellan enters the South Sea at the southern extremity of the country, now first proven to be thus separate and a continent. Men in those days began to think that creation was doubled, and that such discovered lands must be separate from India, China, and Japan. And the very successes of the Portuguese under Vasco da Gama, bringing from their eastern course the expectancy of Asia's wealth, intensely excited the Spaniards to renew their western search.

The Portuguese, led around the Cape of Good Hope, had brought home vast treasures from the East, while the Spanish discoverers, as yet, had not reached the countries either of Montezuma or of the Inca. Their success "troubled the sleep of the Spaniards."

Everything, then, of personal ambition and national pride, the thirst for gold, the zeal of religious proselytism, and the cold calculations of state policy, now concurred in the disposition to sacrifice what Spain already had of most value on the American shores in order to seize upon a greater good, the Indies, still supposed to be near at hand. And since it was now certain that the new lands were not themselves Asia, the next aim was to find the secret of the narrow passage across them which must lead thither. The very configuration of the isthmus strengthened the belief in the existence of such a passage by the number of its openings, which seemed to invite entrance in the expectancy that some one of them must extend across the narrow breadth of land.

For this the Spanish government, in 1514, gave secret orders to D'Avilla, Governor of Castila del Oro, and to Juan de Solis, the navigator, to determine whether Castila del Oro were an island, and to send to Cuba a chart of the coast, if any strait were possible. For this, De Solis visited Nicaragua and Honduras; and later, led far to the south, perished in the La Plata. For this, Magellan entered the straits, which, strangely enough, he affirmed before setting out, that he "would enter," since he "had seen them marked out on the geographer Martin Behaim's globe." For this, Cortez sent out his expeditions on both coasts, exposing his own life and treasure, and sending home to the emperor, in his second relation, a map of the entire Gulf of Mexico (Dispatch from Cortez to Charles V., October 15, 1524). For this great purpose, and in full expectancy of success in it, the whole coast of the New World on each side, from Newfoundland on the northeast, curving westward on the south, around the whole sweep of the Gulf of Mexico, thence to Magellan's Straits, and thence through them up the Pacific to the Straits of Behring, was searched and researched with diligence. "Men could not get accustomed," says Humboldt, "to the idea that the continent extended uninterruptedly both so far north and south." Hence all these large, numerous, and persevering expeditions by the European powers.

Among them, by priority of right and by her energy, was Spain. The great emperor was urgent on the conqueror of Mexico, and on all in subordinate positions in New Spain, to solve the secret of the strait. All Spain was awakened to it. "How majestic and fair was she," says Chevalier, "in the sixteenth century; what daring, what heroism and perseverance! Never had the world seen such energy, activity, or good fortune. Hers was a will that regarded no obstacles. Neither rivers, deserts, nor mountains far higher than those in Europe, arrested her people. They built grand cities, they drew their fleets, as in a twinkling of the eye, from the very forests. A handful of men conquered empires. They seemed a race of giants or demi-gods. One would have supposed that all the work necessary to bind together climates and

oceans would have been done at the word of the Spaniards as by enchantment, and since nature had not left a passage through the center of America, no matter, so much the better for the glory of the human race; they would make it up by artificial communication. What, indeed, was that for men like them? It were done at a word. Nothing else was left for them to conquer, and the world was becoming too small for them."

Certainly, had Spain remained what she then was, what had been in vain sought from nature would have been supplied by man. A canal or several canals would have been built to take the place of the long-desired strait. Her men of science urged it. In 1551, Gomara, the author of the "History of the Indies," proposed the union of the oceans by three of the very same lines toward which, to this hour, the eye turns with hope.

"It is true," said Gomara, "that mountains obstruct these passes, but if there are mountains there are also hands; let but the resolve be made, there will be no want of means; the Indies, to which the passage will be made, will supply them. To a king of Spain, with the wealth of the Indies at his command, when the object to be obtained is the spice trade, what is possible is easy.

But the sacred fire suddenly burned itself out in Spain. The peninsula had for its ruler a prince who sought his glory in smothering free thought among his own people, and in wasting his immense resources in vain efforts to repress it also outside of his own dominions through all Europe. From that hour, Spain became benumbed and estranged from all the advances of science and art, by means of which other nations, and especially England, developed their true greatness.

Even after France had shown, by her canal of the south, that boats could ascend and pass the mountain crests, it does not appear that the Spanish government seriously wished to avail itself of a like means of establishing any communication between her sea of the Antilles and the South Sea. The mystery enveloping the deliberations of the council of the Indies has not always remained so profound that we could not know what was going on in that body. The Spanish government afterward opened up to Humboldt free access to its archives, and in these he found several memoirs on the possibility of a union between the two oceans; but he says that in no one of them did he find the main point, the height of the elevations on the isthmus, sufficiently cleared up, and he could not fail to remark that the memoirs were exclusively French or English. Spain herself gave it no thought. Since the glorious age of Balbao among the people, indeed, the project of a canal was in every one's thoughts. In the very wayside talks, in the inns of Spain, when a traveler from the New World chanced to pass, after making him tell of the wonders of Lima and Mexico, of the death of the Inca, Atahualpa, and the bloody defeat of the Aztecs, and after asking his opinion of El Dorado, the question was always about the two oceans, and what great things would happen if they could succeed in joining them.

During the whole of the seventeenth and eighteenth centuries, Spain had need of the best mode of conveyance for her treasures across the isthmus. Yet those from Peru came by the miserable route from Panama to the deadliest of climates. Porto Bello and her European wares for her colonies toiled up the Chagres river, while the roughest of communication farther north connected the Chimalapa and the Guasacoalcos in Mexico, and the trade there was limited sternly to but one port on each side. As late as Humboldt's visit, in 1802, when remarking upon the "unnatural modes of communication" by which, through painful delays, the immense treasures of the New World passed from Acapulco, Guayaquil, and Lima, to Spain, he says: "These will soon cease whenever an active government, willing to protect commerce, shall construct a good road from Panama to Porto Bello. The aristocratic nonchalance of Spain, and her fear to open to strangers the way to the countries explored for her own profit, only kept those countries closed." The court forbade, on pain of death, the use of plans at different times proposed. They wronged their own colonies by representing the coasts as dangerous and the rivers impassable. On the presentation of a memoir for improving the route through Tehuantepec, by citizens of Oaxaca, as late as 1775, an order was issued forbidding the subject to be mentioned. The memorialists were censured as intermeddlers, and the viceroy fell under the sovereign's displeasure for having seemed to favor the plans.

The great isthmus was, however, further explored by the Spanish government for its own purposes; the recesses were traversed, and the lines of communication which we know to-day were then noted.

In addition to the fact that comparatively little was explored north or south of that which early became the main highway, the Panama route, there is confirmation here of the truth that Spain concealed and even falsified much of her generally accurately made surveys. No stronger proof of this need be asked than that which Alcedo gives in connection with the proposal by Gogueneche, the Biscayan pilot, to open communication by the Atrato and the Napipi. "The Atrato," says the historian, "is navigable for many leagues, but the navigation of it is prohibited under pain of death,

without the exception of any person whatever."

The Isthmus of Nicaragua has always invited serious consideration for a ship canal route by its very marked physical characteristics, among which is chiefly its great depression between two nearly parallel ranges of hills, which depression is the basin of its large lake, a natural and all-sufficient feeder for such a canal.

In 1524 a squadron of discovery sent out by Cortez on the coast of the South Sea, announced the existence of a fresh water sea at only three leagues from the coast; a sea which, they said, rose and fell alternately, communicating, it was believed, with the Sea of the North. Various reconnoissances were therefore made, under the idea that here the easy transit would be established between Spain and the spice lands beyond.

It was even laid down on some of the old maps, that this open communication by water existed from sea to sea; while later maps represented a river, under the name of Rio Partido, as giving one of its branches to the Pacific Ocean and the other to Lake Nicaragua. An exploration by the engineer, Bautista Antonelli, under the orders of Philip II., corrected the false idea of an open strait.

In the eighteenth century a new cause arose for jealousy of her neighbors and for keeping her northern part of the isthmus from their view. In the years 1779 and 1780 the serious purposes of the English government for the occupancy of Nicaragua, awakened the sollicitudes of the Spanish government for this section. The English colonels, Hodgson and Lee, had secretly surveyed the lake and portions of the country, forwarding their plans to London, as the basis of an armed incursion, to renew such as had already been made by the superintendent of the Mosquito coast, forty years before, when, crossing the isthmus, he took possession of Realejo, on the Pacific, seeking to change its name to Port Edward. In 1780, Captain, afterward Lord Nelson, under orders from Admiral Sir Peter Parker, convoyed a force of two thousand men to San Juan de Nicaragua, for the conquest of the country.

In his dispatches, Nelson said: "In order to give facility to the great object of government, I intend to possess the lake of Nicaragua, which, for the present, may be looked upon as the inland Gibraltar of Spanish America. As it commands the only water pass between the oceans, its situation must ever render it a principal post to insure passage to the Southern Ocean, and by our possession of it Spanish America is severed into two."

The passage of San Juan was found to be exceedingly difficult; for the seamen, although assisted by the Indians from Bluetown, scarcely forced their boats up the shoals. Nelson bitterly regretted that the expedition had not arrived in January, in place of the close of the dry season. It was a disastrous failure, costing the English the lives of one thousand five hundred men, and nearly losing to them their Nelson.

At this period, Charles III., of Spain, sent a commission to explore the country. These commissioners reported unfavorably as regarded the route; but fearing further intrusion from England, forbade all access to the coast; even falsifying and suppressing its charts and permanently injuring the navigation of the San Juan and the Colorado by obstructions in their beds.

It is, however, a relief here to learn that when Humboldt visited the New World, he could say: "The time is passed when Spain, through a jealous policy, refused to other nations a thoroughfare across the possessions of which they kept the whole world so long in ignorance. Accurate maps of the coasts, and even minute plans of military positions, are published." It is also true that the Spanish Cortes, in 1814, decreed the opening of a canal, a decree deferred and never executed.

It was reserved for our century to see this great project carried into execution, and it is but just that as a chronicler of events I should connect with the Canal of Panama the name of a family who have done much to bring the scheme, so to say, into practical execution.

As early as the year 1836, Mr. Joly de Sabla turned his views toward the cutting of a canal across the Isthmus of Panama. He resided at the time on the Island of Guadeloupe, one of the French West India Islands, where he possessed large estates. Of a high social position, the representative of one of France's ancient and noble families, with large means at his disposal and of an enterprising spirit much in advance of his time, he was well calculated to carry out such a grand scheme.

He soon set about procuring from the Government of New Granada (now Colombia) the necessary grants and concessions, but much time and many efforts were spent before these could be brought to a satisfactory condition, and it was not until the year 1841 that he could again visit the Isthmus, bringing with him this time, on a vessel chartered by him for the purpose, a corps of engineers and employes, medical staff, etc., etc. After two years spent in exploring and surveying a country at that

time very imperfectly known, he returned to Guadeloupe to find his residence and most of his estates destroyed by the terrible earthquake that visited the island in February, 1843.

Undaunted by this unexpected and severe blow, Mr. De Sabla persisted in his efforts, and in the same year obtained from the French government the establishment of a Consulate at Panama to insure protection to the future canal company, and also the sending of two government engineers of high repute (Messrs. Garella and Courtines), to verify the surveys already made and complete them.

After receiving the respective reports of Garella and Courtines, Mr. De Sabla decided upon first constructing a railway across the Isthmus, postponing the cutting of the canal until this indispensable auxiliary should have rendered it practicable and profitable. He then presented the scheme in that shape to his friends in Paris and London, and formed a syndicate of thirteen members, among whom we may recall the names of the well known Bankers Caillard of Paris, and Baimbridge of London, of Sir John Campbell, then Vice President of the Oriental Steamship Company, of Viscount Chabrol de Chameane, and of Courtines, the exploring engineer.

A new contract was then entered upon with New Granada in June, 1847, and early in 1848, the Syndicate was about to forward to the Isthmus the expedition which was to execute the preliminary works, while the company was being finally organized in Paris, and its stock placed.

The success of the undertaking seemed to be assured beyond peradventure, when the unexpected breaking out of the French revolution in February, 1848, dashed all hopes to the ground. Several of the prominent financiers engaged in the affair, taken by surprise by the suddenness of the revolution, had to suspend their payments and of course to withdraw from the Panama Canal and railroad scheme. Others withdrew from contagious fear and timidity. Finally the term fixed for carrying out certain obligations of the contract expired without their fulfillment by the company, and the concession was forfeited. Another contract was almost immediately applied for and granted with unseemly haste by the President of New Granada to Messrs. Aspinwall, Stephens and Chauncey, which resulted in the construction of the actual Panama Railroad.

These gentlemen acted fairly in the matter, and in 1849, calling Mr. De Sabla to New York, offered him to join them in the new scheme. Unfortunately they had decided upon placing the Atlantic terminus of the railroad upon the low and swampy mud Island of Manzanillo, while Mr. De Sabla insisted on having it on the mainland on the dry and healthy northern shore of the Bay of Limon. They could not come to an understanding on this point, and Mr. De Sabla, whose experience and foresight taught him the dangers that would result to the shipping from the unprotected situation of the projected part (now Colon--Aspinwall), and who well knew the insalubrity of the malarial swamp constituting the Island of Manzanillo, withdrew forever from the undertaking, after having devoted to it without any benefit to himself, the best years of his life and a large portion of his private means.

One of his sons, Mr. Theodore J. de Sabla, after having actively co-operated with Lieutenant Commander Wyse, in the original scheme of the present canal company, is now one of Count de Lesseps's representatives in the City of New York, and a director of the Panama Railroad Company.

---

## **IMPROVED AVERAGING MACHINE.**

At the recent meeting of the American Society of Civil Engineers, in this city, a paper on an improved form of the averaging machine was read by its inventor, Mr. Wm. S. Auchincloss.

The ingenious method by which the weight of the platform is eliminated from the result of the work of the machine was exhibited and explained. This is accomplished by counterweights sliding automatically in tubes, so that in any position the unloaded platform is always in equilibrium. Any combination of representative weights can then be placed on this platform at the proper points of the scale. By then drawing the platform to its balancing point, the location of the center of gravity will at once be indicated on the scale by the pointer over the central trunnion.

The weights may be arranged on a decimal system, with intermediate weights for closer working, or they may be made so as to express multiples or factors.

Each machine is provided with a number of differing scales, divided suitably for various purposes. When the problem is one of time, the scale represents months and days; for problems of proportion, the zero of the scale is at the center of its length; for problems for the location of center of gravity of a system from a fixed point, the



zero is at the extremity of the scale, etc.

The machine exhibited has sixty-three transverse grooves, which, by arrangement of weights, can be made to serve the purposes of two hundred and fifty-two grooves.

The machine is 29 inches in length, 9 inches in width, and weighs about 13 pounds.

With the machine can be found average dates, as, for instance, of purchases and of payments extending over irregular periods; also average prices, as for "futures," in common use among cotton brokers. The problem of average haul, so often presented to the engineer, can be solved with ease and great celerity. Practical examples of the solution of these and a number of other problems involving proportions or averages were given by the author.

## COMPOUND BEAM ENGINE.

The engine represented in Figs. 1 to 4 herewith is intended for a mill, and is of 530 to 800 indicated horse-power, the pressure being seven atmospheres, and the number of revolutions forty-five per minute. As will be seen by the drawing each cylinder is placed in a separate foundation plate, the two connecting rods acting upon cranks keyed at right angles upon the shaft, W, which carries the drum, T. The high-pressure cylinder, C, is 760 mm diameter, the low pressure cylinder being 1,220 mm. diameter, and the piston speed 2.28 m. The drum, which also fulfills the purpose of a fly wheel, is provided with twenty-eight grooves for ropes of 50 mm. diameter. With the exception of the cylinders, pistons, valves, and valve chests, the engines are of the same size, corresponding to the equal maximum pressures which come into action in each cylinder, and in this respect alone the engine differs in principle from an ordinary twin machine.

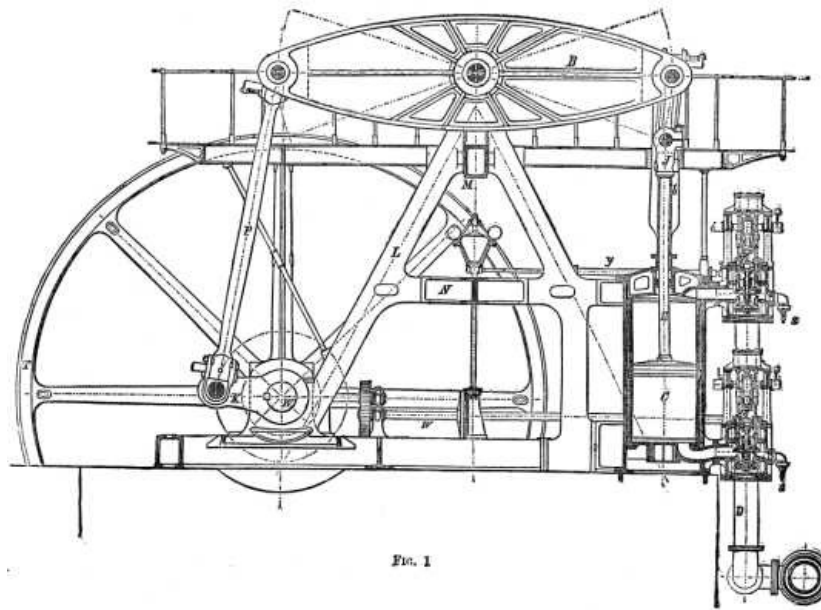

BORSIG'S IMPROVED COPOUND BEAM ENGINE. FIG. 1

The steam passes from the stop-valve, A, Fig. 4, through the steam pipe, D, to the high pressure cylinder, C, and having done its work, goes into the receiver, R, where it is heated. From the receiver it is led into the low-pressure cylinder, C<sup>1</sup>, and thence into the condenser. Provision is made for working both engines independently with direct steam when desired, suitable gear being provided for supplying steam of the proper pressure to the condensing engine, so that each engine shall perform exactly the same amount of work. The starting gear consists of a hand-wheel, H, which controls the stop valve, A, and of another h, which opens the valves for the jackets of the cylinders and receiver. The hand-wheel, h<sup>1</sup> and h<sup>2</sup>, govern the valves, which turn the steam direct into the two cylinders. There are also lever, g, which opens the principal injection cock, H<sup>1</sup>, and the auxiliary injection cock, H<sup>2</sup>, the function of which is to assist in forming a speedy vacuum, when the engine has been standing for some time.

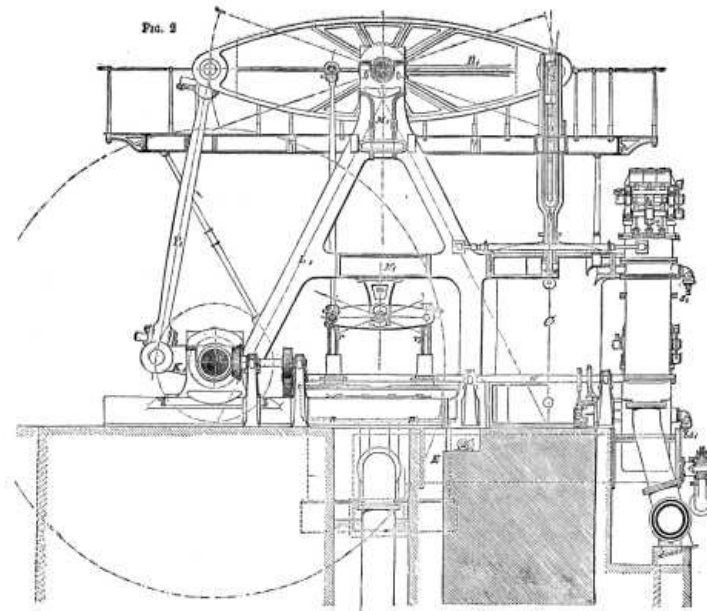

BORSIG'S IMPROVED COPOUND BEAM ENGINE. FIG. 2

The drum is 6.08 m. diameter, the breadth being 2.04 m., with a total weight of 33,000 kilos. The beams are of cast iron with balance weights cast on. The connecting rods and cross beams are of wrought iron, and the cranks, crank shaft, piston rods, valve rods, etc., of steel. The bed-plate for the main shaft bearings are cast in one piece with the standards for the beam, which are connected firmly together by the center bearing,  $M M^1$ , which is cast in one piece, and also by the diagonal bracing piece,  $N N^1$ . The construction of the cylinder and valve chests is shown in Fig. 1. The working cylinder is in the form of a liner to the cylinder, thus forming the steam jacket, with a view to future renewal. This lining has a flange at the lower part for bolting it down, being made steam-tight by the intervention of a copper packing ring. There is a similar ring at the upper part which is pressed down by the cylinder cover. The latter is cast hollow and strengthened by ribs. The pistons are provided with cast iron double self-expanding packing rings. For preventing accidents by condensed water, spring safety valves,  $ss$  and  $s^1 s^1$ , are connected to the valve chests. The valve gear, which is arranged in the same manner for both cylinders, is actuated by shafts,  $w$  and  $w^1$ , rotated by toothed wheels as shown. Motion is communicated from the way-shafts,  $w$  and  $w^1$ , by the eccentrics, and the eccentric rods,  $e^1 e^2 e^3 e^4$ , and the levers and rods belonging thereto, to the short steam valve rocking shafts levers,  $f^1 f^2 f^3 f^4$ , and the exhaust valve rocking shafts,  $k^1 k^2 k^3 k^4$ , the bearings of which are carried on brackets above the valve chests, which, being furnished with tappet levers, raise and lower the valves.

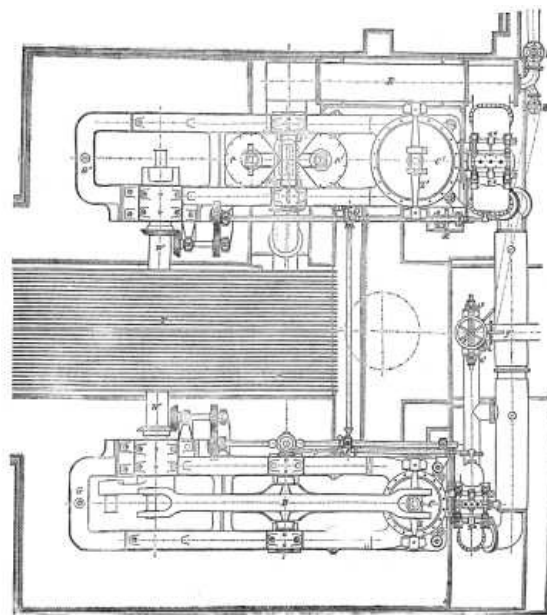

BORSIG'S IMPROVED COPOUND BEAM ENGINE. FIG. 3

The valves are conical, double-seated, and of cast iron, and the inlet and outlet valves are placed the one above the other, the seats being also conically ground and inserted through the cover of the valve chest. Both inlet and outlet valves are

actuated from above, and are removable upward, an arrangement which admits of the valves being more easily examined than when the two are actuated from different sides of the valve chest. To carry out this idea the inlet valves are furnished with two guides, which, passing upward through the stuffing-box, are attached to a hard steel cross piece, which receives the action of a bent catch turning on a pin attached to the levers,  $t_1$ ,  $t_2$ ,  $t_3$ ,  $t_4$ . The exhaust valves, on the contrary, have only one guide each, which passes upward through the seat of the admission valve, through the valve itself by means of a collar, and through the stuffing-box. It is furnished with hard steel armatures, through which the levers,  $z_1$   $z_2$ , Fig. 3, act upon the exhaust valves.

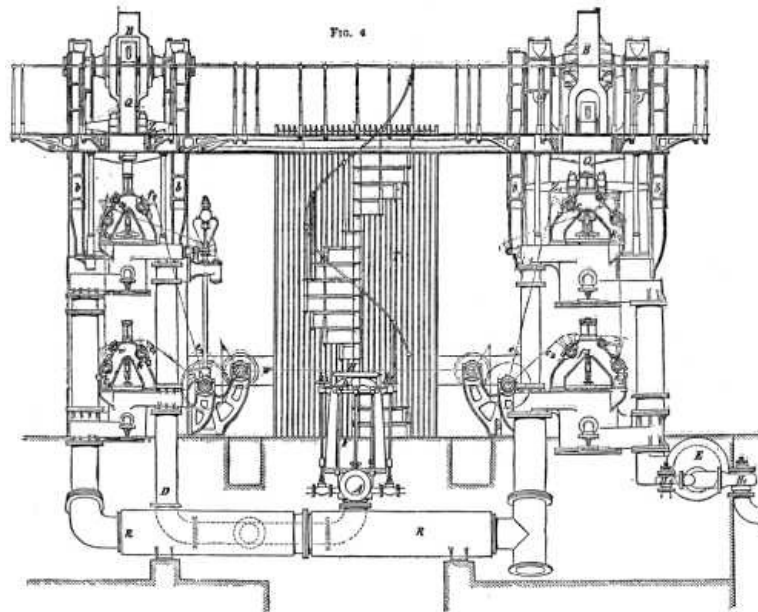

BORSIG'S IMPROVED COPOUND BEAM ENGINE. FIG. 4

The governor effects the acceleration or retardation of the loosening of the catch actuating the steam valve by means of hard steel projections on the shaft,  $v_1$ , the position of which, by means of levers, is regulated by the governor, which in its highest position does not allow the lifting of the inlet valve at all. The regulation of the expansion by the governor from 0 to 0.45 takes place generally only in the case of the high-pressure cylinder, while the low-pressure cylinder has a fixed rate of expansion. Only when the low-pressure cylinder is required to work with steam direct from the boiler is the governor applied to regulate the expansion in it. An exact action in the valve guides and a regular descent is secured by furnishing them with small dash pot pistons working in cylinders. Into them the air is readily admitted by a small India-rubber valve, but the passage out again is controlled at pleasure.--*The Engineer*.

---

TO DETECT ALKALIES IN NITRATE OF SILVER--Stolba recommends the salt to be dissolved in the smallest quantity of water, and to add to the filtered solution hydrofluosilicic acid, drop by drop. Should a turbidity appear an alkaline salt is present. But should the liquid remain limpid, an equal volume of alcohol is to be added, which will cause a precipitate in case the slightest trace of an alkali be present.

---

## **POWER HAMMERS WITH MOVABLE FULCRUM.**

[Footnote: Paper read before the Institution of Mechanical Engineers.--*Engineering*.]

**By DANIEL LONGWORTH, of London.**

The movable-fulcrum power hammer was designed by the writer about five and a half years ago, to meet a want in the market for a power hammer which, while under the complete control of only one workman, could produce blows of varying forces without alteration in the rapidity with which they were given. It was also necessary that the vibration and shock of the hammer head should not be transmitted to the driving mechanism, and that the latter should be free from noise and liability to derangement. The various uses to which the movable fulcrum hammers have been put, and their success in working[1]--as well as the importance of the general subject which includes them, namely, the substitution of stored power for human effort--form the author's excuse for now occupying the time of the meeting.

[Footnote 1: The hammers have been for some years used by A. Bamlett, of Thirsk; the American Tool Company, of Antwerp; Messrs. W.&T. Avery, of Birmingham; Pullar & Sons, of Perth; Salter & Co., of West Bromwich; Vernon Hope & Co., of Wednesbury, etc.; and also for stamps by Messrs. Collins & Co., of Birmingham, etc.]

Until these hammers were introduced, no satisfactory method had been devised for altering the force of the blow. The plan generally adopted was to have either a tightening pulley acting on the driving belt, a friction driving clutch, or a simple brake on the driving pulley, put in action by the hand or foot of the workman. Heavy blows were produced by simply increasing the number of blows per minute (and therefore the velocity), and light blows by diminishing it--a plan which was quite contrary to the true requirements of the case. To prevent the shock of the hammer head being communicated to the driving gear, an elastic connection was usually formed between them, consisting of a steel spring or a cushion of compressed air. With the steel spring, the variation which could be given in the thickness of the work under the hammer was very limited, owing to the risk of breaking the spring; but with the compressed air or pneumatic connection the work might vary considerably in thickness, say from 0 to 8 in. with a hammer weighing 400lb. The pneumatic hammers had a crank, with a connecting rod or a slotted crossbar on the piston-rod, a piston and a cylinder which formed the hammer-head. The piston-rod was packed with a cup leather, or with ordinary packing, the latter required to be adjusted with the greatest nicety, otherwise the piston struck the hammer before lifting it, or else the force of the blow was considerably diminished. As the piston moved with the same velocity during its upward and downward strokes, and, in the latter, had to overtake and outrun the hammer falling under the action of gravity, the air was not compressed sufficiently to give a sharp blow at ordinary working speeds, and a much heavier hammer was required than if the velocity of the piston had been accelerated to a greater degree.

As it is impossible in the limits of this paper to describe all the forms in which the movable fulcrum hammers have been arranged, two types only will be selected taken from actual work; namely, a small planishing hammer, and a medium-sized forging hammer.[1]

[Footnote 1: To the makers, Messrs. J. Scott Rawlings & Co, of Birmingham, the author is indebted for the working drawings of these hammers.]

The small planishing hammer, Figs. 1 to 3, next page, is used for copper, tin, electro, and iron plate, for scythes, and other thin work, for which it is sufficient to adjust the force of the blow once for all by hand, according to the thickness and quality of the material before commencing to hammer it. The hammer weighs 15 lb., and has a stroke variable from 2½ in. to 9½ in., and makes 250 blows per minute. The driving shaft, A, is fitted with fast and loose belt pulleys, the belt fork being connected to the pedal, P, which when pressed down by the foot of the workman, slides the driving belt on to the fast pulley and starts the hammer; when the foot is taken off the pedal, the weight on the latter moves the belt quickly on to the loose pulley, and the hammer is stopped. The flywheel on the shaft, A, is weighted on one side, so that it causes the hammer to stop at the top of its stroke after working; thus enabling the material to be placed on the anvil before starting the hammer. The movable fulcrum, B, consists of a stud, free to slide in a slot, C, in the framing, and held in position by a nut and toothed washer. On the fulcrum is mounted the socket, D, through which passes freely a round bar or rocking lever, E, attached at one end to the main piston, F, of the hammer, G, and having at the other extremity a long slide, H, mounted upon it. This slide is carried on the crank-pin, I, fastened to the disk, J, attached to the driving shaft, A. The crank-pin, in revolving, reciprocates the rocking lever, E, and main piston, F, and through the medium of the pneumatic connection, the hammer, G. The slide, H, in revolving with the crank-pin, also moves backward and forward along the rocking lever, approaching the fulcrum, B, during the down-stroke of the hammer, and receding from it during the up-stroke. By this means the velocity of the hammer is considerably accelerated in its downward stroke, causing a sharp blow to be given while it is gently raised during its upward stroke.

To alter the force of the blow, the hammer, G, is made to rise and fall through a greater or less distance, as may be required, from the fixed anvil block, K, after the manner of the smith giving heavy or light blows on his anvil. It is evident that this special alteration of the stroke could not be obtained by altering the throw of a simple crank and connecting rod; but by placing the slot, C, parallel with the direction of the rocking lever, E, when the latter is in its lowest position, with the hammer resting on the anvil, and with the crank at the top of its stroke, this lowest position of the rocking lever and hammer is made constant, no matter what position the fulcrum, B, may have in the slot, C. To obtain a short stroke, and consequently a light blow, the fulcrum is moved in the slot toward the hammer, G; and to produce a long stroke and heavy blow the fulcrum is moved in the opposite direction.

Fig. 3 gives the details of the pneumatic connection between the main piston and the hammer, in which packing and packing glands are dispensed with. The hammer, G, is

of cast steel, bored out to fit the main piston, F, the latter being also bored out to receive an internal piston, L. A pin, M, passing freely through slots in the main piston, F, connects rigidly the internal piston, L, with the hammer, G. When the main piston is raised by the rocking lever, the air in the space, X, between the main and internal pistons, is compressed, and forms an elastic medium for lifting the hammer; when the main piston is moved down, the air in the space, Y, is compressed in its turn, and the hammer forced down to give the blow. Two holes drilled in the side of the hammer renew the air automatically in the spaces, X and Y, at each blow of the hammer.

Figs. 4 to 6, on the next page, represent the medium size forging hammer, for making forgings in dies, swaging and tilting bars, and plating edged tools, etc.

The hammer weighs 1 cwt., has a stroke variable from 4 in. to 14½ in., and gives 200 blows per minute; the compressed air space between the main piston and the hammer is sufficiently long to admit forgings up to 3 in. thick under the hammer.

To make forgings economically, it is necessary to bring them into the desired form by a few heavy blows, while the material is still in a highly plastic condition, and then to finish them by a succession of lighter blows. The heavy blows should be given at a slower rate than the lighter ones, to allow time for turning the work in the dies or on the anvil, and so to avoid the risk of spoiling it. In forging with the steam hammer the workman requires an assistant, who, with the lever of the valve motion in hand, obeys his directions as to starting and stopping, heavy or light blows, slow or quick blows, etc; the quickest speed attainable depending on the speed of the arm of the assistant. In the movable-fulcrum forging hammer the operations of starting and stopping, and the giving of heavy or light blows, are under the complete control of one foot of the workman, who requires therefore no assistant; and by properly proportioning the diameter of the driving pulley and size of belt to the hammer, the heavy blows are given at a slower rate than the light ones, owing to the greater resistance which they offer to the driving belt.

In this hammer the pneumatic connection, the arrangements for the starting, stopping, and holding up of the hammer, as well as those for communicating the motion of the crank-pin to the hammer by means of a rocking lever and movable fulcrum, are similar to those in the planishing hammer, differing only in the details, which provide double guides and bearings for the principal working parts.

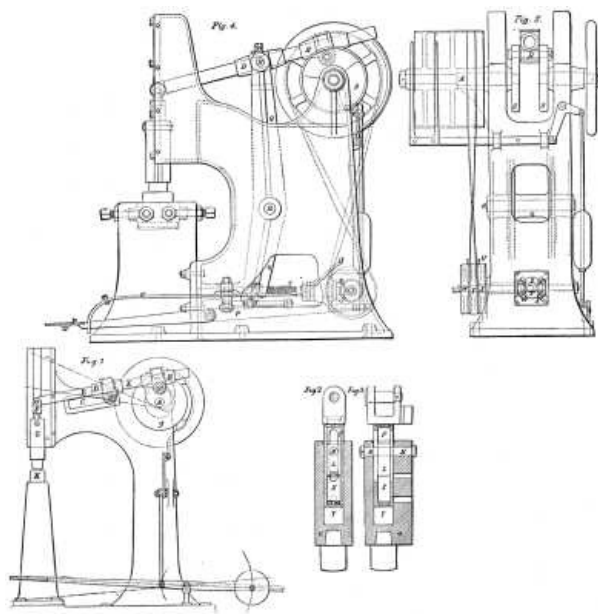

#### LONGWORTH'S POWER HAMMER WITH MOVABLE FULCRUM.

The movable fulcrum, B, Figs. 4 and 5, consists of two adjustable steel pins, attached to the fulcrum lever, Q, and turned conical where they fit in the socket, D. The fulcrum lever is pivoted on a pin, R, fixed in the framing of the machine, and is connected at its lower extremity to the nut, S, in gear with the regulating screw, T. The to-and-fro movement of the fulcrum lever, Q, by which heavy or light blows are given by the hammer, is placed under the control of the foot of the workman, in the following manner: U is a double-ended forked lever, pivoted in the center, and having one end embracing the starting pedal, P, and the other end the small belt which connects the fast pulley on the driving shaft, A, with the loose pulley, V, or the reversing pulleys, W and X. These are respectively connected with the bevel wheels, W<sub>1</sub>, and X<sub>1</sub>, gearing into and placed at opposite sides of the bevel wheel, Z, on the regulating screw in connection with the fulcrum lever. When the workman places his foot on the pedal, P, to start the hammer, he finds his foot within the fork of the

lever, U; and by slightly turning his foot round on his heel he can readily move the forked lever to right or left, so shifting the small belt on to either of the reversing pulleys, W or X, and causing the regulating screw, T, to revolve in either direction. The fulcrum lever is thus caused to move forward or backward, to give light or heavy blows. By moving the forked lever into mid position, the small belt is shifted into its usual place on the loose pulley, V, and the fulcrum remains at rest. To fix the lightest and heaviest blow required for each kind of work, adjustable stops are provided, and are mounted on a rod, Y, connected to an arm of the forked lever. When the nut of the regulating screw comes in contact with either of the stops, the forked lever is forced into mid position, in spite of the pressure of the foot of the workman, and thus further movement of the fulcrum lever, in the direction which it was taking, is prevented. The movable fulcrum can also be adjusted by hand to any required blow, when the hammer is stopped, by means of a handle in connection with the regulating screw.

In conclusion the author wishes to direct attention to the fact, that in many of our largest manufactories, particularly in the midland counties, foot and hand labor for forging and stamping is still employed to an enormous extent. Hundreds of "Olivers," with hammers up to 60 lb. in weight, are laboriously put in motion by the foot of the workman, at a speed averaging fifty blows per minute; while large numbers of stamps, worked by hand and foot, and weighing up to 120 lb., are also employed. The low first cost of the foot hammers and stamps, combined with the system of piece work, and the desire of manufacturers to keep their methods of working secret, have no doubt much to do with the small amount of progress that has been made; although in a few cases competition, particularly with the United States of America, has forced the manufacturer to throw the Oliver and hand-stamp aside, and to employ steam power hammers and stamps. The writer believes that in connection with forging and stamping processes there is still a wide and profitable field for the ingenuity and capital of engineers, who choose to occupy themselves with this minor, but not the less useful, branch of mechanics.

---

## **THE BICHEROUX SYSTEM OF FURNACES APPLIED TO THE PUDDLING OF IRON.**

Since the year 1872, the large iron works at Ougrée, near Liege, have applied the Bicheroux system of furnaces to heating, and, since the year 1877, to puddling. The results that have been obtained in this last-named application are so satisfactory that it appears to us to be of interest to speak of the matter in some detail.

The apparatus, which is shown in the opposite page, consists of three distinct parts: (1) a gas generator; (2) a mixing chamber into which the gases and air are drawn by the natural draught, and wherein the combustion of the gases begins; and (3) a furnace, or laboratory (not represented in the figure), wherein the combustion is nearly finished, and wherein take place the different reactions of puddling. These three parts are given dimensions that vary according to the composition of the different coals, and they may be made to use any sort of coal, even the fine and schistose kinds which would not be suitable for ordinary puddling. The gases and the air necessary for the combustion of these being brought together at different temperatures, and being drawn into the mixing chamber through the same chimney, it will be seen that the dimensions of the flues that conduct them should vary with the kind of coal used; and the manner in which the gases are brought together is not a matter of indifference.

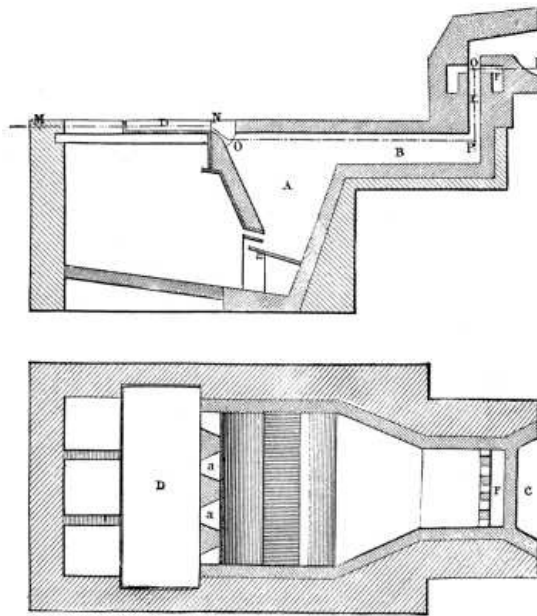

THE BICHEROUX SYSTEM OF FURNACE.

Vertical Section, and Horizontal Section through MNOPQR

The gas generator consists of a hopper, A, into which drops, through small apertures a, the coal piled up on the platform, D. These apertures are closed with coal or bricks. The bottom of the generator is formed of a small standing grate. The coal, on falling upon a mass in a state of ignition, distills and becomes transformed into coke, which gradually slides down over a grate to produce afterward, through its own combustion, a distillation of the coal following it. But as these are features found in all generators we will not dwell upon them.

The gases that are produced flow through a long horizontal flue, B, into a vertical conduit, E, into which there debouches at the upper part a series of small orifices, F, that conduct the air that has been heated. The gases are inflamed, and traverse the furnace c (not shown in the cut), from whence they go to the chimney. Before the air is allowed to reach the intervening chamber it is made to pass into the sole of the furnace and into the walls of the chamber, so that to the advantage of having the air heated there is joined the additional one of having those portions of the furnace cooled that cannot be heated with impunity.

The incompletely burned gases that escape from the furnace are utilized in heating the boilers of the establishment. The dimensions given these furnaces vary greatly according to the charge to be used. All the results at Ougrée have been obtained with 400 kilogramme charges, and the dimensions of the gas generators have been calculated for Six-Bonniers coal, which does not yield over 20 per cent. of gas.

The advantages of this system, which permits of expediting all the operations of puddling, are as follows:

1. A notable economy in fuel, both as regards quantity and quality.
2. Economy resulting from diminution in the waste of metal, with a consequent improvement in the quality of the products obtained.
3. Diminution in cost of repairs.
4. Less rapid wear in the grates.
5. Improvement in the conditions of the work of puddling.

As regards the first of these advantages, it may be stated that the puddling of ordinary Ougrée forge iron, which required with other furnaces 900 to 1,000 kilogrammes of coal, is now performed with less than 600 kilogrammes per ton of the iron produced. The puddling of fine grained iron which required 1,300 to 1,500 kilogrammes of coal is now done with 800. So much for quantity; as for quality the system presents also a very marked advantage in that it requires no rolling coal--the operation of the furnace being just as regular with fine coal, even that sifted through screens of 0.02 meter.

The second class of advantages naturally results from the almost complete prevention of access of cold air. The saving in wastage amounts to 3 or 4 per cent., that is to say, 100 kilogrammes of iron produced is accompanied by a loss of only 9 to 10 kilogrammes, instead of 13 to 15 as ordinarily reckoned.

The diminution in the cost of repairs is due to the fact that the furnace doors, of which there are two, permit of easy access to all parts of the sole; moreover, the coal never coming in contact with the fire-bridges, the latter last much longer than those in other styles of furnaces, and can be used for several weeks without the necessity of the least repair. The reduced wear of the grates results from the low temperature that can be used in the furnace, and the quantity of clinker that can be left therein without interfering with its operation, thus permitting of having the grates always black. These latter in no wise change, and after five months of work the square bars still preserve their sharpness of edges.

As for the improvements in the conditions of the work of puddling, it may be stated that with a uniform price per 100 kilogrammes for all the furnaces, the laborers working at the gas furnaces can earn 25 to 30 per cent. more than those working at ordinary furnaces.

---

## **GESSNER'S CONTINUOUS CLOTH-PRESSING MACHINE.**

It is well known that there are several serious drawbacks in the usual plan of pressing woolen or worsted cloths and felts with press plates, press papers, and presses. Three objections of great weight may be mentioned, and events in Leeds give emphasis to a fourth. The three objections are--the labor required in setting or folding the cloth, the expense of the press papers, and the time required. The fourth objection, about which a dispute has occurred between the press-setters and the master finishers in Leeds, refers to the inapplicability of the common system to long lengths. The men object to these on account of the great labor involved in shifting the heavy mass of cloth and press plates to and from the presses. A minor drawback of this system is that it involves the presence of a fold up the middle of the piece. On account of these drawbacks it has long been understood to be desirable to expedite the process, and also to dispense with the press papers. This is the main purpose of the machine we now illustrate in section, in which the pressing is done continuously by what may be termed a species of ironing. The machine consists of a central hollow cylinder, C, three-quarters of the circumference of which is covered by the hollow boxes, M, heated by steam through the pipes shown, and which are mounted upon the levers, BB', whose fulcra are at bb. By means of the hand-wheel, T, and worm-wheel, n, which closes or opens the levers, BB', the pressure of the boxes upon the central roller may be adjusted at will, the spring-bolt, F, allowing a certain amount of yield. The faces of the press-boxes, MM, are covered by a curved sheet of German silver attached to the point, Y. This sheet takes the place of the press papers in the ordinary process. The course of the cloth through the machine is as follows, and is shown by the arrows: It is placed on the bottom board in front, and in its travel it passes over the rails, O, after which it is operated on by the brush, Z, leaving which it is conveyed over the rails, V and I, the rollers, K and P, and thence between the pressing roller, C, and the German silver press plate covering the heated boxes, M. Leaving these the piece passes over the roller, P, and is cuttled down in the bottom board by the cuttling motion, F, or a rolling-up motion may be applied. The maker states that arrangements for brushing and steaming may also be attached, so that in one passage through the machine a piece may be pressed, brushed, and steamed. The speed of the cylinder may be adjusted according to the quality or requirements of the goods that are under treatment. At the time of our visit, says the *Textile Manufacturer*, printed woolen pieces were being pressed at the rate of about four yards a minute, but higher speeds are often obtained. Messrs. Taylor, Wordsworth & Co., who have erected many of these machines in Leeds, Bradford, and Batley, inform us that they find they are adapted for the pressing of a wide variety of cloths, from Bradford goods and thin serges to the heavy pieces of Dewsbury and Batley. The inventor, Ernst Gessner, of Aue, Saxony, adopts an ingenious expedient for pressing goods with thick lists. He provides an arrangement for moving the cylinder endwise, according to the different widths of the pieces to be treated. One list is left outside at the end of the cylinder, and the other at the opposite end of the pressing boxes. The machine we saw was 80 in. wide on the roller, and it was one the design and construction of which undoubtedly do credit to Mr. Gessner.



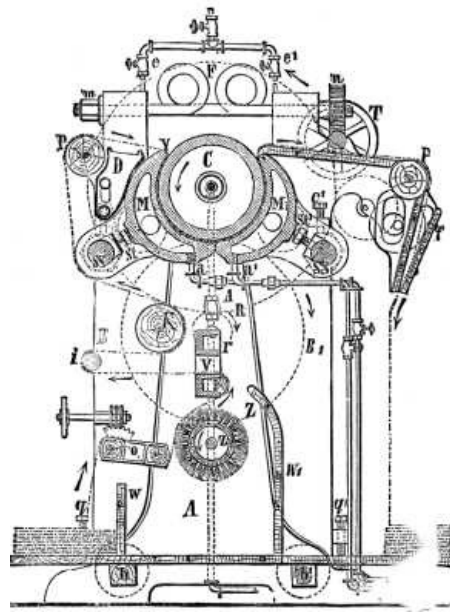

## IMPROVEMENTS IN WOOLEN CARDING ENGINES.

Mr. Bolette, who has made a name for himself in connection with strap dividers, has experimented in another direction on the carding engine, and as his ideas contain some points of novelty we herewith give the necessary illustrations, so that our readers can judge for themselves as to the merit of these inventions.

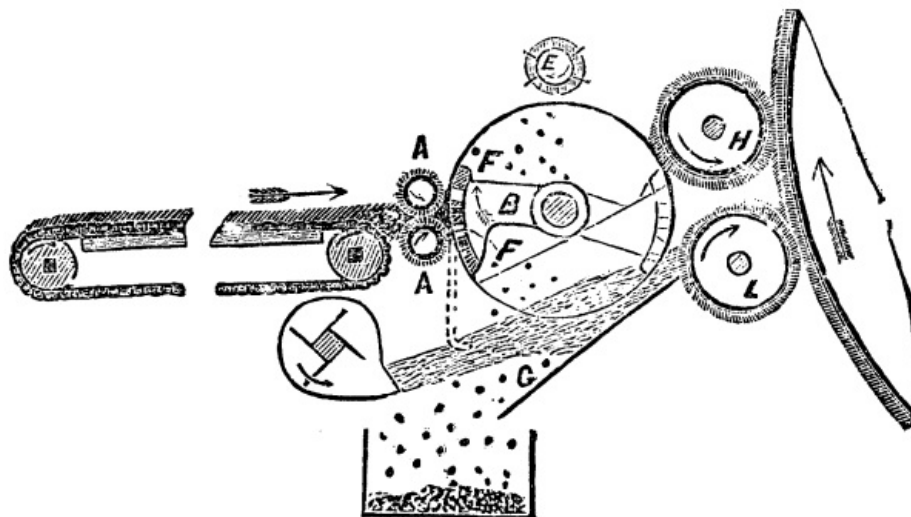

Fig. 1.

Fig. 1 represents the feeding arrangement. Here the wool is delivered by the feed rollers, A A, in the usual manner. The longer fibers are then taken off by a comb, B, and brought forward to the stripper, E, which transfers them to the roller, H, and thence to the cylinder. The shorter fibers which are not seized by the comb fall down, but as they drop they meet a blast of air created by a fan, which throws the lighter and cleaner parts in a kind of spray upon the roller, L, whence they pass on to the cylinder, while the dirt and other heavier parts fall downwards into a box, and are by this means kept off the cylinder. It is evident that in this arrangement it is not intended to keep the long and the short fibers separate, but to utilize them all in the formation of the yarn. The arrangement shown in Fig. 2 refers to the delivery end. Instead of the sliver being wound upon the roller in the usual way, it runs upon a sheet of linen, P<sup>1</sup>, as in the case of carding for felt, with a to-and-fro motion in the direction of the axis of the rollers. In this way one or more layers of the fleece can be placed on the sheet, which in that case passes backwards and forwards from roller S to R, and *vice versa*. It is, in fact, the bat arrangement used for felt, only with this difference, that the bat is at once rolled up instead of going through the bat frame. In the manufacture of felt it is of course of importance to have many very thin layers of fleece superposed over each other in order to equalize it, and if the same is applied to the manufacture of cloth it will no doubt give satisfactory results, but may be rather costly.

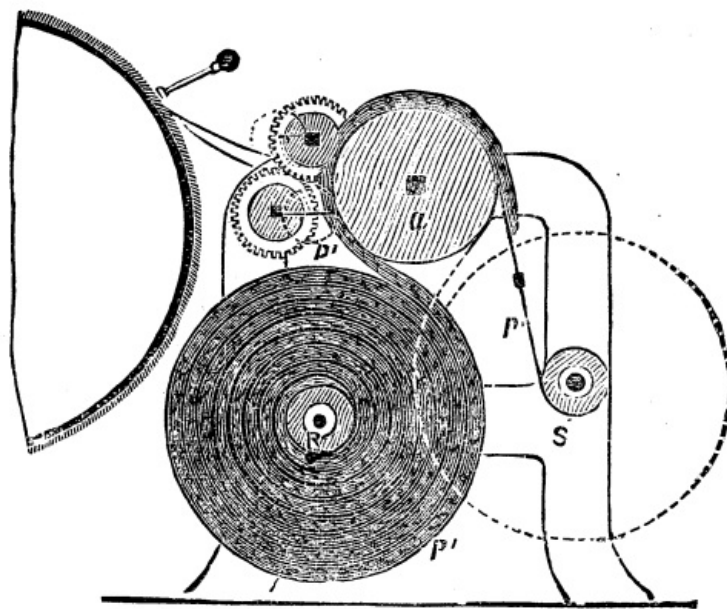

Fig. 2.

## NOVELTIES IN RING SPINDLES.

One of the drawbacks of ring spinning is the uneven pull of the traveler, which is the more difficult to counteract as it is exerted in jerks at irregular intervals. It is argued that with spindles and bearings as usually made the spindle is supported firmly in its bearing, and cannot give in case of such a lateral pull when exerted through the yarn by the traveler, and the consequence is either a breakage of the yarn or an uneven thread. Impressed with this idea, and in order to remedy this defect, an eminent Swiss firm has hit upon the notion of driving the spindle by friction, and to make it more or less loose in the bearings, so that in case of an extra pull by the traveler the spindle can give way a little, and thus prevent the breakage of the yarn. This idea has been carried out in four different ways, and as this seems to be an entirely new departure in ring spinning, we give the illustrations of their construction in detail.

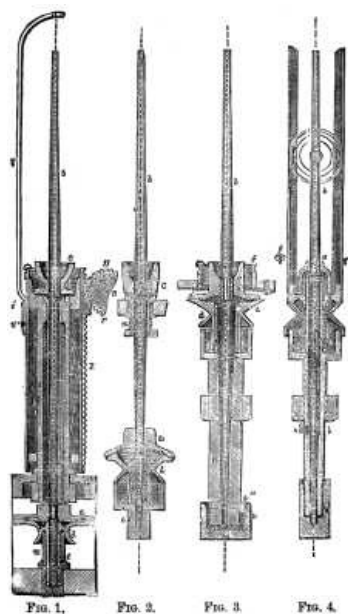

Fig. 1. Fig. 2. Fig. 3. Fig. 4.

Fig. 1 represents Bourcart's recent arrangement of attaching the thread guide to the spindle rail and the adjustable spindle. The spindle is held by the sleeve, *g*, which latter is screwed into the spindle rail, *S*, this being moved by the pinion, *a*; the collar is elongated upwards in a cuplike form, *c*, the better to hold the oil, and keep it from flying; *d* is the wharf, which has attached to it the sleeve, *m*, and which is situated loosely in the space between the spindle and the footstep, *e*. Above the wharf the spindle is hexagonal in shape, and to this part is attached the friction plate, *a*. Between the latter and the upper surface of the wharf a cloth or felt washer is inserted, to act as a brake. The footstep, *e*, is filled with oil, in which run the foot of the spindle and the sleeve *m*, the latter turning upon a steel ring situated on the bottom of the footstep. As, thus, the foot of the spindle is quite free, the upper part of

the spindle can give sideways in the direction of any sudden pull, and the foot of the spindle can follow this motion in the opposite direction, the collar forming the fulcrum for the spindle. By this alteration of the vertical position of the spindle into an inclined one (though ever so trifling), the contact of the friction plate, a, and the wharf is interrupted, and thus the speed of the spindle reduced. This will cause less yarn to be wound on, and the pull thus to be neutralized; but as the wharf keeps turning at the same speed, its centrifugal force will act again upon the friction plate, and thus bring the spindle back to its vertical position as soon as the extra drag has been removed.

In Fig. 2 the footstep, e, has the foot of the spindle more closely fitting at the bottom, but the upper part of the step opens out gradually, and forms a conical cavity of a little larger diameter than the spindle, so that the latter has a considerable play sideways. The wharf carries in its lower part the sleeve, g, which runs upon a steel ring as above. The upper surface of the wharf is arched, and upon this is fitted the correspondingly arched friction plate, a, which latter is attached to the spindle by a screw. The position of the spindle is maintained by the collar, m. This collar is loose in the spindle rail, and only held by the spring, m'. If now, a lateral drag is exerted upon the upper part of the spindle, the collar car follows the direction of this drag, and the spindle thus be brought out of the vertical position, the friction plate slipping at the same time. The force of the spring conjointly with the centrifugal force will then bring back the spindle into its normal position as soon as the drag is again even.

Fig. 3 shows a spindle with a very long conical oil vessel, B, resting upon a disk, e", in cup, e', with a cover, e'''. The wharf, d, is here situated high up the spindle, has the same sleeve as in the preceding case, and runs round the bush, g, upon the ring, z. The friction plate resting upon the wharf is joined to the collar, a, running out into a cup shape, which is fixed to the spindle, which here has a hexagonal form. In this case the collar gives with the spindle, which latter has the necessary play in the long footstep; and as the collar and friction-plate are one, it is brought back to its normal place by centrifugal force.

A peculiar arrangement is shown in Fig. 4. Here the ring and traveler, f, are placed as usual, but the spindle carries at the same time an inverted flier, t. The spindle turns loosely in the footstep, e, the oil chamber being carried up to the middle of its height. The wharf is placed in the same position as in the previous case, having also a sleeve running in the oil chamber, c, upon a steel ring, z. The friction-plate a, on the top of the wharf carries the flier, and on its upper surface is in contact with the inverted cup, a, which is attached to the spindle by a pin or screw. In order to limit at will the lateral motion of the spindle there is attached to the latter, between the footstep and the collar, a split ring, i, which can be closed more or less by a small set screw. The spindle is thus only held in the perpendicular position by its own velocity, which will facilitate a high degree of speed, through the entire absence of all friction in the bearings, this vertical position being assisted by the friction motion whenever the spindle has been drawn on one side. Although the notion of mounting spindles so that they can yield in order to center themselves is not new, it is evident that considerable ingenuity has been brought to bear upon the arrangement of the spindles we have described, but we are not in a position to say to what extent practice has in this case coincided with theory.--*Textile Manufacturer*.

## PHOTO-ENGRAVING ON ZINC OR COPPER.

By LEON VIDAL.

This process is similar in many respects to the one which was some time ago communicated to the Photographic Society of France by M. Stronbinsky, of St. Petersburg, but in a much improved and complete form. An account of it was given by M. Gobert, at the meeting of the same society, on the 2d December, 1882. The following are the details, as demonstrated by me at the meeting of the 9th of May last:

Sheets of zinc or of copper of a convenient size are carefully planished and polished with powdered pumice stone. The sensitive mixture is composed of:

The whites of four fresh eggs beaten		
to a froth.....	100	parts
Pure bichromate of ammonia.....	2.50	"
Water.....	50	"

After this mixture has been carefully filtered through a paper filter, a few drops of ammonia are added. It will keep good for some time if well corked and preserved from exposure to the light. Even two months after being prepared I have found it to be still good; but too large a quantity should not be prepared at a time, as it does not improve with keeping.

I find that the dry albumen of commerce will answer as well as the fresh. In that case I employ the following formula:

Dry albumen from eggs.....	15 to 20	parts
Water.....	100	"
Ammonia bichromate.....	2.50	"

Always add some drops of ammonia, and keep this mixture in a well corked bottle and in a dark place.

To coat the metal plate, place it on a turning table, to which it is made fast at the center by a pneumatic holder; to assure the perfect adhesion of this holder, it is as well to wet the circular elastic ring of the holder before applying it to the metallic surface. When this is done, the table may be made to rotate quickly without fear of detaching the plate by the rapidity of the movement. The plate is placed in a perfectly horizontal position, where no dust can settle on it; the mixture is then poured on it, and distributed by means of a triangular piece of soft paper, so as to cover equally all the parts of the plate. Care should be taken not to flow too much liquid over the plate, and when the latter is everywhere coated, the excess is poured off into a different vessel from that which contains the filtered mixture, or else into a filter resting on that vessel. The turning table should now be inverted so that the sensitive surface may be downwards, and it is made to rotate at first slowly, afterwards more rapidly, so as to make the film, which should be very thin, quite smooth and even. The whole operation should be carried out in a subdued light, as too strong a light would render insoluble the film of bichromated albumen.

When the film is equalized the plate must be detached from the turning table and placed on a cast iron or tin plate heated to not more than 40° or 50° C. A gentle heat is quite sufficient to dry the albumen quickly; a greater heat would spoil it, as it would produce coagulation. So soon as the film is dry, which will be seen by the iridescent aspect it assumes, the plate is allowed to cool to the ordinary temperature, and is then at once exposed either beneath a positive, or beneath an original drawing the lines of which have been drawn in opaque ink, so as to completely prevent the luminous rays from passing through them; the light should only penetrate through the white or transparent ground of the drawing.

I say a *positive* because I wish to obtain an engraved plate; if I wanted to have a plate for typographic printing, I should have to take a *negative*. After exposure the plate must be at once developed, which is effected by dissolving in water those parts of the bichromated gelatine which have been protected from the action of light by the dark spaces of the cliché; these parts remain soluble, while the others have been rendered completely insoluble. If the plate were dipped in clear water it would be difficult to observe the picture coming out, especially on copper. To overcome this difficulty the water must be tinged with some aniline color; aniline red or violet, which are soluble in water, answers the purpose very well. Enough of the dye must be dissolved in the water to give it a tolerably deep color. So soon as the plate is plunged into this liquid the albumen not acted on by light is dissolved, while the insoluble parts are colored by absorbing the dye, so that the metal is exposed in the lines against a red or violet ground, according to the color of the dye used.

When the drawing comes out quite perfect, and a complete copy of the original, the plate with the image on it is allowed to dry either of its own accord, or by submitting it to a gentle heat. So soon as it is dry it is etched, and this is done by means of a solution of perchloride of iron in alcohol. Both alcohol and iron perchloride will coagulate albumen; their action, therefore, on the image will not be injurious, since they will harden the remaining albumen still further. But to get the full benefit of this, the alcohol and the iron perchloride must both be free from water; it is therefore advisable to use the salt in crystals which have been thoroughly dried, and the alcohol of a strength of 95°.

The following is the formula:

Perchloride of iron, well dried	50 gr.
Alcohol at 95°	100 "

This solution must be carefully filtered so as to get rid of any deposit which may form, and must be preserved in a well-corked bottle, when it will keep for a long time. The plate is first coated with a varnish of bitumen of Judea on the edges (if those parts are not already covered with albumen) and on the back, so that the etching liquid can only act on the lines to be engraved. It is then placed, with the side to be engraved downwards, in a porcelain basin, into which a sufficient quantity of the solution of perchloride of iron is poured, and the liquid is kept stirred so as to renew the portion which touches the plate; but care must be taken not to touch with the brush the parts where there is albumen remaining. The length of time that the etching must be continued depends on the depth required to be given to the engraving; generally a quarter of an hour will be found to be sufficient. Should it be thought desirable to extend the action over half an hour, the lines will be found to

have been very deeply engraved. When the etching is considered to have been pushed far enough, the plate must be withdrawn from the solution, and washed in plenty of water; it must then be forcibly rubbed with a cloth so as to remove all the albumen, and after it has been polished with a little pumice, the engraving is complete.

It will be seen that this process may be used with advantage instead of that of photo-engraving with bitumen, in cases where it is not advisable to use acids. One of my friends, Mr. Fisch, suggests the plan--which seems to deserve a careful investigation--of combining this process with that where bitumen is employed; it would be done somewhat in the following way. The plate of metal would be first coated evenly with bitumen of Judea on the turning table, and when the bitumen is quite dry, it should be again coated with albumen in the manner as described above. In full sunlight the exposure need not exceed a minute in length; then the plate would be laid in colored water, dried, and immersed in spirits of turpentine. The latter will dissolve the bitumen in all the parts where it has been exposed by the removal of the albumen not rendered insoluble by the action of light. But it remains to be seen whether the albumen will not be undermined in this method; therefore, before recommending the process, it ought to be thoroughly studied. The metal is now exposed in all the parts that have to be etched, while all the other parts are protected by a layer of bitumen coated with coagulated albumen. Hence we may employ as mordant water acidulated with 3, 4, or 5 per cent. of nitric acid, according as it is required to have the plate etched with greater or less vigor.

By following the directions above given, any one wishing to adopt the process cannot fail of obtaining good results, One of its greatest advantages is that it is within the reach of every one engaged in printing operations.--*Photo News*.

---

## MERIDIAN LINE.

[Footnote: From Proceedings of the Association of County Surveyors of Ohio, Columbus, January, 1882.]

The following process has been used by the undersigned for many years. The true meridian can thus be found within one minute of arc:

*Directions.*--Nail a slat to the north side of an upper window--the higher the better. Let it be 25 feet from the ground or more. Let it project 3 feet. Near the end suspend a plumb-bob, and have it swing in a bucket of water. A lamp set in the window will render the upper part of the string visible. Place a small table or stand about 20 feet south of the plumb-bob, and on its south edge stick the small blade of a pocket knife; place the eye close to the blade, and move the stand so as to bring the blade, string, and polar star into line. Place the table so that the star shall be seen very near the slat in the window. Let this be done half an hour before the greatest elongation of the star. Within four or five minutes after the first alignment the star will have moved to the east or west of the string. Slip the table or the knife a little to one side, and align carefully as before. After a few alignments the star will move along the string--down, if the elongation is west; up, if east. On the first of June the eastern elongation occurs about half-past two in the morning, and as daylight comes on shortly after the observation is completed, I prefer that time of year. The time of meridian passage or of the elongation can be found in almost any work on surveying. Of course the observer should choose a calm night.

In the morning the transit can be ranged with the knife blade and string, and the proper angle turned off to the left, if the elongation is east; to the right, if west.

Instead of turning off the angle, as above described, I measure 200 or 300 feet northward, in the direction of the string, and compute the offset in feet and inches, set a stake in the ground, and drive a tack in the usual way.

Suppose the distance is 250 feet and the angle  $1^{\circ} 40'$ , then the offset will be 7,271 feet, or 7 feet  $3\frac{1}{4}$  inches. A minute of arc at the distance of 250 feet is seven-eighths of an inch; and this is the most accurate way, for the vernier will not mark so small a space accurately.

## ANGLE OF ELONGATION.

This should be computed by the surveyor for each observation. The distance between the star and the pole is continually diminishing, and on January 1, 1882, was  $1^{\circ} 18' 48''$ .

There is a slight annual variation in the distance. July 1, 1882, it will be  $1^{\circ} 19' 20''$ . If from this latter quantity the observer will subtract 16" for 1883, and the same quantity for each succeeding year for the next four or five years, no error so great as

one-quarter of a minute will be made in the position of the meridian as determined in the summer months. If winter observations are made, the distance in January should be used. The formula for computing the angle of elongation is easily made by any one understanding spherical trigonometry, and is this:

$$\frac{R \times \sin. \text{ Polar dist.}}{\cos. \text{ lat.}} = \sin. \text{ of angle of elongation.}$$

As an example, suppose the time is July, 1882, and the latitude 40°. Then the computation being made, the angle will be found to be 1° 43' 34". A difference of six minutes in the latitude will make less than 10" difference in the angle, as one can see by trial. Any good State or county map will give the latitude to within one or two miles--or minutes.

The facts being as here stated, the absurdity of the Ohio law, concerning the establishment of county meridians, becomes apparent. The longitude has nothing at all to do with the meridian; and a difference of *six miles* in latitude makes no appreciable error in the meridian established as here suggested, whereas the statute requires the latitude within *one half a second*, which is *fifty feet*. There are some other things, besides the ways of Providence, which may be said to be "past finding out." It is not probable that a surveyor would err so much as *three miles* in his latitude, but should he do so, then the error in his meridian line, resulting from the mistake, will be *five seconds*, and a line *one mile* long, run on a course 5" out of the way, will vary but *an inch and a half* from the true position. Surveyors well know that no such accuracy is attainable. R. W. McFARLAND,

---

## ELECTRO-MANIA.

By W. MATTIEU WILLIAMS.

A history of electricity, in order to be complete, must include two distinct and very different subjects: the history of electrical science, and a history of electrical exaggerations and delusions. The progress of the first has been followed by a crop of the second from the time when Kleist, Muschenbroek, and Cuneus endeavored to bottle the supposed fluid, and in the course of these attempts stumbled upon the "Leyden jar."

Dr. Lieberkuhn, of Berlin, describes the startling results which he obtained, or imagined, "when a nail or a piece of brass wire is put into a small apothecary's phial and electrified." He says that "if, while it is electrifying, I put my finger or a piece of gold which I hold in my hand to the nail, I receive a shock which stuns my arms and shoulders." At about the same date (the middle of the last century), Muschenbroek stated, in a letter to Réaumur, that, on taking a shock from a thin glass bowl, "he felt himself struck in his arms, shoulders, and breast, so that he lost his breath, and was two days before he recovered from the effects of the blow and the terror" and that he "would not take a second shock for the kingdom of France." From the description Of the apparatus, it is evident that this dreadful shock was no stronger than many of us have taken scores of times for fun, and have given to our school-follows when we became the proud possessors of our first electrical machine.

Conjurers, mountebanks, itinerant quacks, and other adventurers operated throughout Europe, and were found at every country fair and *fete* displaying the wonders of the invisible agent by giving shocks and professing to cure all imaginable ailments.

Then came the discoveries of Galvani and Volta, followed by the demonstrations of Galvani's nephew Aldini, whereby dead animals were made to display the movements of life, not only by the electricity of the Voltaic pile, but, as Aldini especially showed, by a transfer of this mysterious agency from one animal to another.

According to his experiments (that seem to be forgotten by modern electricians) the galvanometer of the period, a prepared frog, could be made to kick by connecting its nerve and muscle with muscle and nerve of a recently killed ox, with, or without metallic intervention.

Thus arose the dogma which still survives in the advertisements of electrical quacks, that "electricity is life," and the possibility of reviving the dead was believed by many. Executed criminals were in active demand; their bodies were expeditiously transferred from the gallows or scaffold to the operating table, and their dead limbs were made to struggle and plunge, their eyeballs to roll, and their features to perpetrate the most horrible contortions by connecting nerves with one pole, and muscles with the opposite pole of a battery.

The heart was made to beat, and many men of eminence supposed that if this could

be combined with artificial respiration, and kept up for awhile, the victim of the hangman might be restored, provided the neck was not broken. Curious tales were loudly whispered concerning gentle hangings and strange doings at Dr. Brookes's, in Leicester Square, and at the Hunterian Museum, in Windmill Street, now flourishing as "The Café de l'Etoile." When a child, I lived about midway between these celebrated schools of practical anatomy, and well remember the tales of horror that were recounted concerning them. When Bishop and Williams (no relation to the writer) were hanged for burking, i.e., murdering people in order to provide "subjects" for dissection, their bodies were sent to Windmill Street, and the popular notion was that, being old and faithful servants of the doctors, they were galvanized to life, and again set up in their old business.

It is amusing to read some of the treatises on medical galvanism that were published at about this period, and contrast their positive statements of cures effected and results anticipated with the position now attained by electricity as a curative agent.

Then came the brilliant discoveries of Faraday, Ampère, etc., demonstrating the relations between electricity and magnetism, and immediately following them a multitude of patents for electro-motors, and wild dreams of superseding steam-engines by magneto-electric machinery.

The following, which I copy from the *Penny Mechanic*, of June 10, 1837, is curious, and very instructive to those who think of investing in any of the electric power companies of to-day: "Mr. Thomas Davenport, a Vermont blacksmith, has discovered a mode of applying magnetic and electro-magnetic power, which we have good ground for believing will be of immense importance to the world." This announcement is followed by reference to Professor Silliman's *American Journal of Science and the Arts*, for April, 1837, and extracts from American papers, of which the following is a specimen: "1. We saw a small cylindrical battery, about nine inches in length, three or four in diameter, produce a magnetic power of about 300 lb., and which, therefore, we could not move with our utmost strength. 2. We saw a small wheel, five-and-a-half inches in diameter, performing more than 600 revolutions in a minute, and lift a weight of 24 lb. one foot per minute, from the power of a battery of still smaller dimensions. 3. We saw a model of a locomotive engine traveling on a circular railroad with immense velocity, and rapidly ascending an inclined plane of far greater elevation than any hitherto ascended by steam-power. And these and various other experiments which we saw, convinced us of the truth of the opinion expressed by Professors Silliman, Renwick, and others, that the power of machinery may be increased from this source beyond any assignable limit. It is computed by these learned men that a circular galvanic battery about three feet in diameter, with magnets of a proportionable surface, would produce at least a hundred horse-power; and therefore that two such batteries would be sufficient to propel ships of the largest class across the Atlantic. The only materials required to generate and continue this power for such a voyage would be a few thin sheets of copper and zinc, and a few gallons of mineral water."

The Faure accumulator is but a very weak affair compared with this, Sir William Thomson notwithstanding. To render the date of the above fully appreciable, I may note that three months later the magazine from which it is quoted was illustrated with a picture of the London and Birmingham Railway Station displaying a first-class passenger with a box seat on the roof of the carriage, and followed by an account of the trip to Boxmoor, the first installment of the London and North-Western Railway. It tells us that, "the time of starting having arrived, the doors of the carriages are closed, and, by the assistance of the conductors, the train is moved on a short distance toward the first bridge, where it is met by an engine, which conducts it up the inclined plane as far as Chalk Farm. Between the canal and this spot stands the station-house for the engines; here, also, are fixed the engines which are to be employed in drawing the carriages up the inclined plane from Euston Square, by a rope upwards of a mile in length, the cost of which was upwards of £400." After describing the next change of engines, in the same matter of course way as the changing of stage-coach horses, the narrative proceeds to say that "entering the tunnel from broad daylight to perfect darkness has an exceedingly novel effect."

I make these parallel quotations for the benefit of those who imagine that electricity is making such vastly greater strides than other sources of power. I well remember making this journey to Boxmoor, and four or five years later traveling on a circular electro-magnetic railway. Comparing that electric railway with those now exhibiting, and comparing the Boxmoor trip with the present work of the London and North-Western Railway, I have no hesitation in affirming that the rate of progress in electro-locomotion during the last forty years has been far smaller than that of steam.

The leading fallacy which is urging the electro-maniacs of the present time to their ruinous investments is the idea that electro-motors are novelties, and that electric-lighting is in its infancy; while gas-lighting is regarded as an old, or mature middle-aged business, and therefore we are to expect a marvelous growth of the infant and

no further progress of the adult.

These excited speculators do not appear to be aware of the fact that electric-lighting is older than gas-lighting; that Sir Humphry Davy exhibited the electric light in Albemarle Street, while London was still dimly lighted by oil-lamps, and long before gas-lighting was attempted anywhere. The lamp used by Sir Humphry Davy at the Royal Institution, at the beginning of the present century, was an arrangement of two carbon pencils, between which was formed the "electric arc" by the intensely-vivid incandescence and combustion of the particles of carbon passing between the solid carbon electrodes. The light exhibited by Davy was incomparably more brilliant than anything that has been lately shown either in London, or Paris, or at Sydenham. His arc was *four inches in length*, the carbon pencils were four inches apart, and a broad, dazzling arch of light bridged the whole space between. The modern arc lights are but pygmies, mere specks, compared with this; a leap of 1/3 or 1/4 inch constituting their maximum achievement.

Comparing the actual progress of gas and electric lighting, the gas has achieved by far the greater strides; and this is the case even when we compare very recent progress.

The improvements connected with gas-making have been steadily progressive; scarcely a year has passed from the date of Murdoch's efforts to the present time, without some or many decided steps having been made. The progress of electric-lighting has been a series of spasmodic leaps, backward as well as forward.

As an example of stepping backward, I may refer to what the newspapers have described as the "discoveries" of Mr. Edison, or the use of an incandescent wire, or stick, or sheet of platinum, or platino-iridium; or a thread of carbon, of which the "Swan" and other modern lights are rival modifications.

As far back as 1846 I was engaged in making apparatus and experiments for the purpose of turning to practical account "King's patent electric light," the actual inventor of which was a young American, named Starr, who died in 1847, when about 25 years of age, a victim of overwork and disappointment in his efforts to perfect this invention and a magneto-electric machine, intended to supply the power in accordance with some of the "latest improvements" of 1881 and 1882.

I had a share in this venture, and was very enthusiastic until after I had become practically acquainted with the subject. We had no difficulty in obtaining a splendid and perfectly steady light, better than any that are shown at the Crystal Palace.

We used platinum, and alloys of platinum and iridium, abandoned them as Edison did more than thirty years later, and then tried a multitude of forms of carbon, including that which constitutes the last "discovery" of Mr. Edison, viz., burnt cane. Starr tried this on theoretical grounds, because cane being coated with silica, he predicted that by charring it we should obtain a more compact stick or thread, as the fusion of the silica would hold the carbon particles together. He finally abandoned this and all the rest in favor of the hard deposit of carbon which lines the inside of gas-retorts, some specimens of which we found to be so hard that we required a lapidary's wheel to cut them into the thin sticks.

Our final wick was a piece of this of square section, and about 1/8 of an inch across each way. It was mounted between two forceps--one holding each end, and thus leaving a clear half-inch between. The forceps were soldered to platinum wires, one of which passed upward through the top of the barometer tube, expanded into a lamp glass at its upper part. This wire was sealed to the glass as it passed through. The lower wire passed down the middle of the tube.

The tube was filled with mercury and inverted over a cup of mercury. Being 30 inches long up to the bottom of the expanded portion, or lamp globe, the mercury fell below this and left a Torricellian vacuum there. One pole of the battery, or dynamo-machine, was connected with the mercury in the cup, and the other with the upper wire. The stick of carbon glowed brilliantly, and with perfect steadiness.

I subsequently exhibited this apparatus in the Town-hall of Birmingham, and many times at the Midland Institute. The only scientific difficulty connected with this arrangement was that due to a slight volatilization of the carbon, and its deposition as a brown film upon the lamp glass; but this difficulty is not insuperable.--  
*Knowledge.*

---

## **ACTION OF MAGNETS UPON THE VOLTAIC ARC.**

The action of magnets upon the voltaic arc has been known for a long time past. Davy even succeeded in influencing the latter powerfully enough in this way to divide it, and since his time Messrs. Grove and Quet have studied the effect under different



conditions. In 1859, I myself undertook numerous researches on this subject, and experimented on the induction spark of the Ruhmkorff coil, the results of these researches having been published in the last two editions of my notes on the Ruhmkorff apparatus.

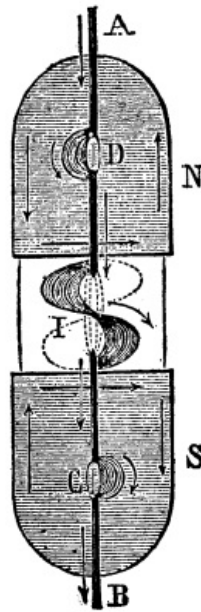

FIG. 1

These researches were summed up in the journal *La Lumière Electrique* for June 15, 1879. Recently, Mr. Pilleux has addressed to us some new experiments on the same subject, made on the voltaic arc produced by a De Meritens alternating current machine. Naturally, he has found the same phenomena that I had made known; but he thinks that these new researches are worthy of interest by reason of the nature of the arc in which he experimented, and which, according to him, is of a different nature from all those on which, up to the present time, experiments have been made. Such a distinction as this, however, merits a discussion.

With the induction spark, magnets have an action only on the aureola which accompanies the line of fire of the static discharge; and this aureola, being only a sort of sheath of heated air containing many particles of metal derived from the rheophores, represents exactly the voltaic arc.

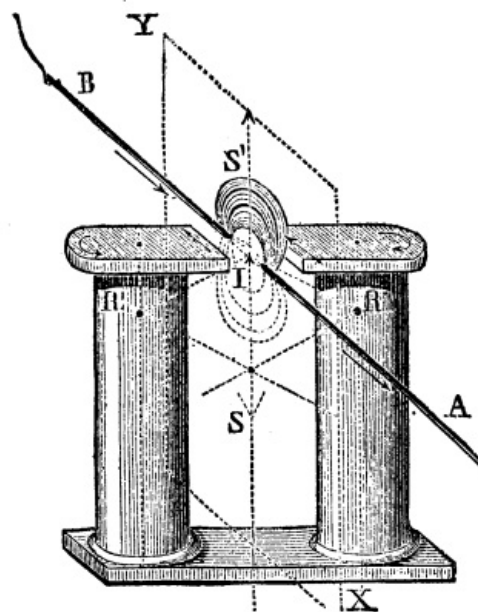

FIG. 2

Moreover, although the induced currents developed in the bobbin are alternately of opposite direction, the galvanometer shows that the currents that traverse the break are of the same direction, and that these are direct ones. The reversed currents are, then, arrested during their passage; and, in order to collect them, it becomes necessary to considerably diminish the gaseous pressure of the aeriform conductor interposed in the discharge; to increase its conductivity; or to open to the current a very resistant metallic derivation. By this latter means, I have succeeded in isolating, one from the other, in two different circuits, the direct induced currents and the

reversed induced ones. As only direct currents can, in air at a normal pressure, traverse the break through which the induction spark passes, the aureola that surrounds it may be considered as being exactly in the same conditions as a voltaic arc, and, consequently, as representing an extensible conductor traversed by a current flowing in a definite direction. Such a conductor is consequently susceptible of being influenced by all the external reactions that can be exerted upon a current; only, by reason of its mobility, the conductor may possibly give way to the action exerted upon the current traversing it, and undergo deformations that are in relation with the laws of Ampère. It is in this manner that I have explained the different forms that the aureola of the induction spark assumes when it is submitted to the action of a magnet in the direction of its axial line, or in that of its equatorial line, or perpendicular to these latter, or upon the magnetic poles themselves.

Experiments of a very definite kind have not yet been made as to the nature of the arc produced by induced currents developed in alternating current machines; but, from the experiments made with electric candles, we are forced to admit that the current reacts as if it were alternately reversed through the arc, since the carbons are used up to an equal degree; and, moreover, Mr. Pilleux's experiments show that effects analogous to those of induction coils are produced by the reaction of magnets upon the arc. There is, then, here a doubtful point that it would be interesting to clear up; and we believe that it is consequently proper to introduce in this place Mr. Pilleux's note:

"Having at my disposal," says he, "a powerful vertical voltaic arc of 12 centimeters in length, kept up by alternately reversed currents, and one of the most powerful permanent magnets that Mr. De Meritens employs for magneto-electric machines, I have been enabled to make the following experiments:

"1. When I caused one of the poles of my magnet to slowly approach the voltaic arc, I ascertained that, at a distance of 10 centimeters, the arc became flattened so as to assume the appearance of those gas jets called 'butterfly.' The plane of the 'butterfly' was parallel with the pole that I presented, or, in other words, with the section of the magnet. At the same time, the arc began to emit a strident noise, which became deafening when the pole of the magnet was brought to within a distance of about 2 millimeters. At this moment, the butterfly form produced by the arc was *greatly spread out, and reduced to the thickness of a sheet of paper*; and then it burst with violence, and projected to a distance a great number of particles of incandescent carbon.

"2. The magnet employed being a horseshoe one, when I directed it laterally so as to present successively, now the north and then the south pole to the arc, the 'butterfly' pivoted upon itself so as not to present the same surface to each pole of the magnet."

By referring to the accompanying figure, which we extract from our note on the Ruhmkorff apparatus, it will be seen that the aureola which developed as a circular film from right to left at D, on the north pole of the magnet, N.S. (Fig. 1), projected itself in an opposite direction at C, upon the south pole, S, of the same magnet; but, between the two poles, these two contrary actions being obliged to unite, they gave rise in doing so to a very characteristic helicoid spiral whose direction depended upon that of the current of discharge through the aureola, or upon the polarity of the magnetic poles. On the contrary, when the discharge took place in the direction of the equatorial line, as in Fig. 2, the circular film developed itself in the plane of the neutral line above or below the line of discharge, according to the direction of the current and the magnetic polarity of the magnet.

There is, then, between Mr. Pilleux's experiments and my own so great an analogy that we might draw the deduction therefrom that induced currents in alternating machines have, like those of the Ruhmkorff coil, a definite direction, which would be that of currents having the greatest tension, that is to say, that of direct currents. This hypothesis seems to us the more plausible in that Mr. J. Van Malderem has demonstrated that the attraction of solenoids with the currents, not straight, of magneto-electric machines is almost as great as that of the same solenoids with straight currents; and it is very likely that the difference which may then exist should be so much the less in proportion as the induced currents have more tension. We might, then, perhaps explain the different effects of the wear of the carbons serving as rheophores, according as the currents are continuous or alternating, by the different calorific effects produced on these carbons, and by the effects of electric conveyance which are a consequence of the passage of the current through the arc.

We know that with continuous currents the positive carbon possesses a much higher temperature than the negative, and that its wear is about twice greater than that of the latter. But such greater wear of the positive carbon is especially due to the fact that combustion is greater on it than on the negative, and also to the fact that the carbonaceous particles carried along by the current to the positive pole are deposited in part upon the other pole. Supposing that these polarities of the carbons were being constantly alternately reversed, the effects might be symmetrical from all

quarters, although the only current traversing the break were of the same direction; for, admitting that the reverse currents could not traverse the break, they would exist none the less for all that, and they might give rise (as has been demonstrated by Mr. Gaugain with regard to the discharges of the induction spark intercepted by the insulating plate of a condenser) to return discharges through the generator, which would then have, in the metallic part of the circuit, the same direction as the direct currents succeeding, although they had momentarily brought about opposite polarities in the electrodes. What might make us suppose such an interpretation of the phenomenon to have its *raison d'être*, is that with the induced currents of the Ruhmkorff coil, it is not the positive pole that is the hottest, but rather the negative; from whence we might draw the deduction that it is not so much the direction of the current that determines the calorific effect in the electrodes, as the conditions of such current with respect to the generator. I should not be surprised, then, if, in the arc formed by the alternating currents of magneto-electric machines, there should pass only one current of the same direction, and which would be the one formed by the superposition of direct currents, and if the reverse currents should cause return discharges in the midst of the generating bobbins at the moment the direct currents were generated.--*Th. Du Moncel.*

---

## **VOLCKMAR'S SECONDARY BATTERIES.**

The inventive genius of the country is now directed to these important accessories of electric enterprise, and no wonder, for as far as can at present be seen, the secret of electric motion lies in these secondary batteries. Among other contributions of this kind is the following, by Ernest Volckmar, electrician, Paris:

The object of this invention is to render unnecessary the use in secondary batteries of a porous pot which creates useless resistance to the electric current, and to store in an apparatus of comparatively small weight and bulk considerable electric force. To this end two reticulated or perforated plates of lead of similar proportions are prepared, and their interstices are filled with granules or filaments of lead, by preference chemically pure. These plates are then submitted to pressure, and placed together, with strips of nonconducting material interposed between them, in a suitable vessel containing a bath of acidulated water. The plates being connected with wires from an electric generator are brought for a while under the action of the current, to peroxidize and reduce the whole of the finely divided lead exposed to the acidulated water. The secondary battery is then complete. It will be understood that any number of these pairs of plates may be combined to form a secondary battery, their number being determined by the amount of storage required. The perforated plates of lead may be prepared by drilling, casting, or in other convenient manner, but the apertures, of whatever form, should be placed as closely together as possible, and the finely divided lead to be peroxidized is pressed into the cells or cavities so as to fill their interiors only.

---

## **THE MINERALOGICAL LOCALITIES IN AND AROUND NEW YORK CITY, AND THE MINERALS OCCURRING THEREIN.**

**By NELSON H. DARTON.**

There will be many persons in the city of New York and its suburbs who will not have the time or facilities for leaving town during the summer, to spend a part of their time enjoying the country, but would have sufficient time to take occasional recreation for short periods. I have sought by this paper to show a pleasurable, and at the same time very instructive use for the time of this latter class, and that is in mineralogy. In the surrounding parts of New York are many mineralogical localities, known to no others than a few professional mineralogists, etc., and from which an excellent assortment of minerals may be obtained, which would well grace a cabinet and afford considerable instruction and entertainment to their owner and friends, besides acting as an incentive to a further study of this and the other sciences. These localities which I will discuss are all within an hour's ride from New York, and the expenses inside of a half dollar, and generally very much less. I could detail many other places further off, but will reserve that for another paper.

The course which I will pursue in my explanations I have purposely made very simple, avoiding--or when using, explaining--all technical terms. The apparatus and tests noticed are of the most rudimentary style consistent with that which is necessary to attain the simple purpose of distinguishment, and altogether I have prepared this paper for those having at the present time little or no knowledge or practice in mineralogy, while those having it can be led perhaps by the details of the

localities noticed. Another reason why I have written so in detail of this last subject is, because the experiences of most amateur mineralogists are generally so very discouraging in their endeavors to find the minerals, and there is everything in giving a good start to properly fix the interest on the subject. The reason of these discouragements is simple, and generally because they do not know the portion of the locality, say, for instance, a certain township, in which the minerals occur. And if they do succeed in finding this, it is seldom that the portion in which the mineral occurs, which is generally some small inconspicuous vein or fissure, is found; and even in this it is generally difficult to recognize and isolate the mineral from the extraneous matter holding it. As an instance of this I might cite thus: Dana, in his text book on mineralogy, will mention the locality for a certain species, as Bergen Hill--say for this instance, dogtooth calcspar. When we consider that Bergen Hill, in the limited sense of the expression, is ten miles long and fully one mile wide, and as the rock outcrops nearly all over it, and it is also covered with quarries, cuttings, etc., it may be seen that this direction is rather indefinite. To the professional mineralogist it is but an index, however, and he may consult the authority it is quoted from--the *American Journal of Science*, etc.--and thus find the part referred to, or by consulting other mineralogists who happen to know. Again, the person having found by inquiry that the part referred to is the Pennsylvania Railroad, and as this is fully a mile long and interspersed with various prominent looking, but veins of a mineral of little value, at any rate not the one in question, they are few who could suppose that it occurred in that. Apparently a vein of it would not be noticed at all from the surrounding rock of gravelly earth, but there it is, and in a vein of chlorite. This is so throughout the long and more or less complete stated lists of mineralogical localities. Thus I will, in describing the mineral, after explaining the conditions under which it occurs, give almost the exact spot where I have found the same mineral myself, and have left sufficiently fine specimens to carry away, and thus no time will be lost in going over fruitless ground, and further, this paper is written up to the date given at its end, insuring a necessary presence of them.

In order that one not familiar with mineral specimens should not carry off from the various localities a variety of worthless stones, etc., which are frequently more or less attractive to an inexperienced eye, the following hints may be salutary.

There are the varieties of three minerals, which are very commonly met with in greater or less abundance in mineralogical trips: they are of calcite, steatite, and quartz. They occur in so many modifications of form, color, and condition that one might speedily form a cabinet of these, if they were taken when met with, and imagine it to be of great value. The first of these is calcite. It occurs as marble, limestone; calcspar, dogtooth spar, nail head spar, stalactites, and a number of other forms, which are only valuable when occurring in perfect crystals or uniquely set upon the rock holding it. The calcspar is extremely abundant at Bergen Hill, where it might be mistaken for many of the other minerals which I describe as occurring there, and even in preference to them, to one's great chagrin upon arriving home and testing it, to find that it is nothing but calcite. In order to avoid this and distinguish this mineral on the field, it should be tested with a single drop of acid, which on coming in contact with it bubbles up or effervesces like soda water, seidlitz powder, etc., while it does not do so with any of the minerals occurring in the same locality. This acid is prepared for use as follows: about twenty drops of muriatic acid are procured from a druggist in a half-ounce bottle, which is then filled up with water and kept tightly corked. It is applied by taking a drop out on a wisp of broom or a small minim dropper, which may be obtained at the druggist's also. I do not say that in every case this mineral should be rejected, because it is frequently very beautiful and worthy of place in a cabinet, but should be kept only under the conditions mentioned further on in this paper, under the head of "Calcite in Weehawken Tunnel."

The next mineral abundant in so many forms is quartz, and is not so readily distinguished as calcite. It is found of every color, shape, etc., possible, and that which is found in any of the localities I am about to describe, with the exception of fine crystals on Staten Island, are of no value and may be rejected, unless answering in detail to the description given under Staten Island. The method of distinguishing the quartz is by its hardness, which is generally so great that it cannot be scratched by the point of a knife, or at least with great difficulty, and a fragment of it will scratch glass readily; thus it is distinguished from the other minerals occurring in the localities discussed in this paper.

The other minerals so common are the varieties of steatite. This is especially so at Bergen Hill and Staten Island. They occur in amorphous masses generally, and may be distinguished by being so soft as to be readily cut by the finger nail. I will detail further upon the soapstone forms in discussing the localities on Staten Island, and the chloritic form under the head of "Weehawken Tunnel." The surest method of avoiding these and recognizing the others by their appearance, which is generally the only guide used by a professional mineralogist, is to copy off the lists of the various minerals I describe, and, by visiting the American Museum of Natural History

on any week day except Mondays and Tuesdays, one may see and become familiar with the minerals they are going in quest of, besides others in the cases. This method is much more satisfactory than printed descriptions, and saves the labor of many of the distinguishing manipulations I am about to describe, besides saving the trouble of bringing inferior specimens of the minerals home.

In going forth on a trip one should be provided with a mineralogical hammer, or one answering its purpose, and a cold chisel with which to detach or trim the minerals from adhering rocks, the bottle of acid before referred to, and a three cornered file for testing hardness, as explained further on. As I noticed before, the better plan of distinguishing a mineral is by being familiar with its appearance, but as this is generally impracticable, I will detail the modes used in lieu of this to be applied on bringing the minerals home. These distinguishments depend on difference in specific gravity, hardness, solubility in hot acids, and the action of high heat. I will explain the application of each one separately, commencing with--

*The Specific Gravity.*--In ascertaining the specific gravity the following apparatus is necessary: a small pair of hand scales with a set of weights, from one grain to one ounce. These can be procured from the apparatus maker, the scales for about fifty cents, and the weights for not much over the same amount. The scales are prepared for this work by cutting two small holes in one of the scale pans, near together, with a pointed piece of metal, and tying a piece of silk thread about eight inches long into these. In a loop at the end of this thread the mineral to be examined is suspended. It should be a pure representative of the mineral it is taken from, should weigh about from one hundred grains to an ounce, and be quite dry and free from dirt. If the piece of mineral obtained is very large, this sized portion may be often taken from it without injury; but it will not do to mar the beauty of a mineral to ascertain its specific gravity, and it is generally only applicable when a small piece is at hand. With more weights, however, a piece of a quarter pound weight may be taken if necessary. The mineral is tied into the loop and weighed, the weight being set down in the note book, either in grains or decimal parts of an ounce. Call this result A. It is then weighed in some water held in a vessel containing about a quart, taking care while weighing it that it is entirely immersed, but at the same time does not touch either the sides or bottom. Both weighings should be accurate to a grain. This result we call B. The specific gravity is found by subtracting B from A, and dividing A by the remainder. For instance, if the mineral weighed eight hundred grains when weighed in the air, and in the water six hundred, giving us the equation:  $800 / (800 - 600) =$  sp. gr., or 4, which is the specific gravity of the mineral. If the mineral whose specific gravity is sought is an incrustation on a rock, or a mixture of a number of minerals, or would break to pieces in the water, the specific gravity is by this method of course unattainable, and other data must be used.

*The Comparative Hardness.*--The next characteristic of the mineral to be ascertained is the comparative hardness. In mineralogy there is a scale fixed for comparison, from 1 to 10, 10 being the hardest, the diamond, and Number 1 the soft soapstone. These and the intermediate minerals fixed upon the scale are generally inaccessible to those who may use the contents of this paper, and I will give some more familiar materials for comparison. 8, 9, and 10 are the topaz, sapphire, and diamond respectively, and as these and minerals of similar hardness will probably not be found in any of the localities of which I make mention, we need not become accustomed to them for the present. 7 is of sufficient hardness to scratch glass, and is also not to be cut with the file before mentioned, which is used for these determinations. 6 is of the hardness of ordinary French glass. 5 is about the hardness of horse-shoe or similar iron; 4 of the brown stone (sandstone) of which the fronts of many city buildings, etc., are built; 3 of marble; 2 of alabaster; and 1 as French chalk, or so soft as to be readily cut with the finger nail. The method of using and applying these comparisons is by having the above matters at hand, and compare them by the relative ease with which they can be cut by running the edge of the file over their surface. One will soon become familiar with the scale, and it may of course then be discarded. As it is one of the most important characteristics of some of the minerals, it should be carefully executed, and the result carefully considered. It is of course inapplicable under those conditions with minerals that are in very small crystals or in a fibrous condition.

*Action of Hot Acids.*--This very important test is never, like the above, applicable upon the field, but applied when home is reached. From the body of the mineral as pure and clean as possible a portion is chipped, about the size of a small pea; this is wrapped in a piece of stiff wrapping paper, and after placing it in contact with a solid body, crushed finally by a blow from the hammer. A pinch of the powder so obtained is taken up on the point of a penknife, and transferred into a test tube. Two or more of these should be provided, about six inches long. They may be obtained in the apparatus shop for a trifle. Some hydrochloric, or, as it is generally called, muriatic acid, is poured upon it to the depth of about three quarters of an inch; the tube is then placed in some boiling water heated over a lamp in a tinned or other vessel, and allowed to boil for from ten to fifteen minutes; the tube is then removed and its

contents allowed to cool, and then examined. If the powder has all disappeared, we term the mineral "soluble;" if more or less is dissolved, "partly soluble;" if none, "insoluble;" and if the contents of the tube are of a solid transparent mass like jelly, "gelatinous;" while if transparent gelatinous flakes are left, it is so termed. As this method of distinguishment is always applicable, it is very important, and its detail and result should be carefully noticed. Care should be taken that only a small portion of the mineral is used, and also but little acid; the action should be observed, and is frequently a characteristic, in the case with calcspar, which effervesces while dissolving. The acid used is hydrochloric at first, and then, if the mineral cannot be recognized, the same treatment may be repeated using nitric acid. Both of these acids should be at hand and two ounces are generally sufficient.

*Action of Heat.*--This is, perhaps, the most important characteristic, and, when taken with the preceding data, will identify any of the minerals found in any one locality, which I will describe, from each other. The heat is applied to the mineral by means of a candle and blowpipe. A thick wax candle answers well, and an ordinary japanned tin blowpipe, costing twenty cents, will serve the purpose. The substance to be examined is held on a loop of platinum wire about one inch to the left and just below the top of the wick, which is bent toward it. Here it is steadily held, as is shown in Fig. 1, and the flame of the candle bent over upon it, and the heat intensified by blowing a steady and strong current of air across it by means of the blowpipe held in the mouth and supported by the right hand, whose elbow is resting upon the table. The current of air is difficult to keep up by one unaccustomed to the blowpipe, the skill of using which is readily obtained; it consists in breathing through the nostrils, while the air is forced out by pressure on the air held by the inflated cheeks, and not from the lungs. This can be practiced while not using the blow-pipe, and may readily be accomplished by one's keeping his cheeks distended with air and breathing at the same time.

This heat is steadily applied until the splinter of mineral has been kept at a high red heat for a sufficient length of time to convince one of what it may do, as fuse or not, or on the edges. The first two are evident, as when it fuses it runs into a globule; the last, by inspecting it before and after the heating with a magnifying glass; sometimes it froths up when heated, and is then said to "intumesce;" or, if it flies to fragments, "decrepitates." Upon the first it is further heated; but in the latter case, a new splinter of mineral must be broken off from the mass and heated upon the wire very cautiously until quite hot, when it may then be readily heated further without fear of loss. For holding the splinter of mineral, which should well represent the mass and be quite small, is a three-inch length of platinum wire of the thickness of a cambric-needle; this may be bought for about ten cents at the apparatus shop. The ends should be looped, as is shown in Fig. 2, and the mineral placed in the loop.

Sometimes a mineral has to be fused with borax, as I mention further on in my tables. This is done by heating the wire-loop to redness, and plunging it into some borax; what adheres is fused upon it by heating. Some more is accumulated in the same manner, until the loop is filled with a fair-sized globule. A small quantity of the mineral, which had been crushed as for the acid test, is caused to adhere to it while it is molten, and then the heat of the blast directed upon it for some time until either the small fragments of mineral dissolve, or positively refuse to do so. After cooling, the aspect of the globule is noticed as to color, transparency, etc. Care must be taken that too large an amount of the mineral is not taken, a very minute amount being sufficient.

I trust by the use of these distinguishing reactions one will be able to recognize by the tables to be given the name of the mineral in hand, especially as they are from certain parts, where all the minerals occurring therein are known to us; and I have worded the characteristics so that they will serve to isolate from all that possibly could be found in that locality.

The first general locality is Bergen Hill, New Jersey. This comprises the range of bluffs of trap rock commencing at Bergen Point and running up behind Jersey City and Hoboken, etc., to the part opposite about Thirtieth Street, New York, where it comes close to the river, and from there along the river to the north for a long distance, known as the Palisades. It is about a mile wide on an average, and from a few feet to about two hundred feet in height. The mineralogical localities in and upon it are at the following parts, commencing at the south: First Pennsylvania Railroad cuts where the mining operations are just about completed; then the Erie Tunnel, in which the specimens that first made Bergen Hill noted as a mineralogical locality, and whose equals have not since been procured, were found, but which is now inaccessible to the general public. Further north is the Morris and Essex Tunnel, in which many fine specimens were secured, and is also inaccessible; and last, but far from being least, is the Ontario Tunnel at Weehawken; and, as it is the only practicable part besides the Pennsylvania Railroad and a number of surface outcrops which I will mention, I will commence with that.

*The Weehawken Tunnel.*--This tunnel is now being cut through the trap-rock for the

New York, Ontario, and Western Railroad, and will be completed in a few months, but will, probably, be available as a mineralogical locality for a year to come. It is located about half a mile south of the Weehawken Ferry from Forty-second Street, New York city, and the place where to climb upon the hill to get to the shafts leading to it is made prominent by the large body of light-colored rock on the dump, a few rods north of where the east entrance is to be. The western end is in the village of New Durham, on the New Jersey Northern Railroad, and recognized by the immense earth excavations. A pass is necessary to gain admittance down the shafts, and this can be procured from the office of the company, between the third and fourth shafts to the tunnel, in the grocery and provision store just to the north of the tramway connecting the shafts on the surface. As it will not be necessary to go down in any of the shafts besides the first and second in order to fulfill the objects of this paper, no difficulty need be encountered in procuring the pass if this is stated.

These two shafts are about eight hundred feet apart and one hundred and seventy feet deep. A platform elevator is the mode of access to the tunneled portion below, and a free shower-bath is included in the descent; consequently, a rubber-coat and water tight boots are necessary. A pair of overalls should be worn if one is to engage in any active exploration below; candles should also be provided, as the electric lights, at the face of the headings, give but little light, and remind one very forcibly of a dim flash light with a foliated tree in front of it. The electric wires for supplying these arrangements run along the north side of the tunnel for those on the east headings, and on the south side for the west. They are excellent things to keep clear of, as they have sufficient current passing through them to knock one down; thus their position can be readily ascertained.

*Modes of Occurrence of the Minerals.*--In general, the greater number of the specimens which are to be found in the tunnel occur in veins generally perpendicular, and with other minerals of little or no value, as calcite, chlorite, and imperfect crystals of the same mineral. A few occur in nodules inclosed in the solid body of rock, and in which condition they are seldom of value. The greater abundance are in the veins of the dark-green soft chlorite, and some few in horizontal beds. The minerals are found in the first condition by examining all the veins running from floor to ceiling of the tunnel. The ores of calcite first mentioned are very conspicuous, they being white in the dense black rock. They may be chipped from, as there are about thirty or forty of them exposed in each shaft, and the character of the minerals examined to see if anything but calcite is in it. This is ascertained by a drop of acid, as explained before, and by the descriptions given further on. The veins of chlorite are not so conspicuous, being of a dark-green color; but by probing along the walls with a stick or hammer, they may be recognized by their softness, or by its dull glistening appearance. They are comparatively few, but from an inch to three feet wide; and minerals are found by digging it out with a stick or a three-foot drill, to be had at the headings. Where the most minerals occur in the chlorite is when plenty of veins of calcite are in its vicinity, and its edges near the trap are dry and crumbly. It is here where the minerals are found in this crumbly chlorite, and generally in geodes--that is, the faces of the minerals all point inward, formerly a spherical mass--rough and uncouth on the outside, and from half an inch to nearly a foot in diameter. These are valuable finds, and well worth digging for. The beds of minerals generally are of but one species, and will be mentioned under the head of the minerals occurring in them. Besides, in the tunnel there are generally more or less perfect minerals upon the main dump over the edge of the bluff toward the river. Here many specimens that have escaped the eyes of the miners may be found among the loose rock, being constantly strewn out by the incline of the bed; in fact, this is the only place in which quite a number of the incident minerals may be found; but I will not linger longer on this, as I shall refer to it under the minerals individually.

The minerals occurring at the tunnel are as follows, with their descriptions and locations in the order of their greatest abundance:

*Calcite.*--This mineral occurs in great abundance in and about the tunnel, and from all the shafts. There are two forms occurring there, the most abundant of which is the rhombohedral, after Fig. 3. It can generally be obtained, however, in excellent crystals, which, although perfect in form, are opaque, but often large and beautiful. It is always packed with a thousand or its multiple of other crystals into veins of a few inches thick; and crystals are obtained by carefully breaking with edge of the cold chisel these masses down to the fundamental form shown. As the masses are never secured by the miners, they can always be picked from the piles of *débris* around the shafts and the dumps, and afford some little instruction as to the manner in which a mineral is built up by crystallization, and may be subdivided by cleavage to a crystal of the same shape exactly, but infinitesimally small. A crystal to be worth preserving should be about an inch in diameter, and as transparent as is attainable.

Another form of calcite which is to be sparingly found is what is called dogtooth spar, having the form shown in Fig. 4. They occur in clear wine-yellow-colored crystals,

from a quarter to half an inch in length; they occur in the chlorite in geodes of variable sizes, but generally two and a half inches in diameter, and which, when carefully broken in half, showed beautiful grottoes of these crystals. The few of these that I have found were in the four-foot vein of chlorite down the Shaft No. 1, to the west of the shaft about one hundred and fifty feet, and on the south wall; it may be readily found by probing for it, and then the geodes by digging in. There need be no difficulty in finding this vein if these conditions are carefully considered, or if one of the miners be asked as to the soft vein. Both these forms of calcite may be distinguished from the other minerals by first effervescing on coming in contact with the acids; second, by glowing with an intense (almost unbearably so) light when heated with the blowpipe, but not fusing. Their specific gravity is 2.6, or near it, and hardness about 3, or equal to ordinary unpolished white marble.

*Natrolite*.--The finest specimens of this mineral that have ever been found in Bergen Hill were taken from a bed of it in this tunnel, having in its original form, before it was cut out by the tunnel passing through, over one hundred square feet, and from one-half to two and a half and even three inches in thickness; it was in all possible shapes and forms--all extremely rare and beautiful. A large part of one end of this bed still remains, and, by careful cutting, fine masses may be obtained. This bed may be readily found; it is nearly horizontal, and in its center about four feet from the floor of the tunnel, and about half an inch thick. It is down Shaft No. 2, on the north wall, and commences about eighty feet from the shaft. It is cut into in some places, but there is plenty more left, and can be obtained by cutting the rock above it and easing it out by means of the blade of a knife or similar instrument. This natrolite is a grouping of very small but perfect crystals, having the forms shown in Fig. 5; they are from a quarter to an inch long, and, if not perfectly transparent, are of a pure white color; they may be readily recognized by their form, and occurring in this bed. Its hardness, which is seldom to be ascertained owing to the delicacy of the crystals, is about 5, and the specific gravity 2.2. This is readily found, but is no distinction; its reaction before the blowpipe, however, is characteristic, it readily fusing to a transparent globule, clear and glassy, and by forming a jelly when heated with acids. The bed holding the upright crystals is also natrolite in confused matted masses. This mineral has also been found in other parts of the shaft, but only in small druses. There is a prospect at present that another bed will be uncovered soon, and some more fine specimens to be easily obtained.

*Pectolite*, or as it is termed by the miners, "silky spar."--This mineral is quite abundant and in fine masses, not of the great beauty and size of those taken from the Erie Tunnel, but still of great uniqueness. The mineral is recognized by its peculiar appearance, as is shown in Fig. 6, where it may be seen that it is in groups of fine delicate fibers about an inch long, diverging from a point into fan-shaped groups. The fibers are very tightly packed together, as are also the groups; they are very tough individually, and have a hardness of 4, and a specific gravity of about 2.5. It gelatinizes on boiling with acid, and a fragment may be readily fused in the blowpipe flame, yielding a transparent globule. The appearance is the most striking characteristic, and at once distinguishes this mineral from any of the others occurring in this locality. Considerable quantities of pectolite may generally be found on the dump, but also in Shaft No. 1, and especially No. 2. The veins of it are difficult to distinguish from the calcite, as they are almost identical in color, and many of the calcite veins are partly of pectolite--in fact, every third or fourth vein will contain more or less of it. There is, however, a very fine vein of pectolite about twenty-five feet further east from the natrolite bed; it runs from the floor to ceiling, and is about two inches in thickness; some specimens of which I took from these were unusually unique in both size and appearance. It makes a very handsome specimen for the cabinet, and should be carefully trimmed to show the characteristics of the mineral.

*Datholite*.--This mineral has been found very frequently in the tunnel, it occurring in pockets in the softer trap near the chlorite, and also in the latter, generally at a depth of one hundred and fifty feet from the surface, and consequently near the ceiling of the tunnel. All that has been found of any great beauty has been in the western end of the Shaft No. 1 and the eastern of Shaft No. 2, where the trap is quite soft; here it is found nearly every day in greater or less quantity, and from this some may generally be found on the dump, or, in the vein of chlorite which I mentioned as a locality for the dogtooth spar, considerable may be obtained in it and on its western edge near the ceiling. A ladder about thirteen feet long is used for attending the lights, and may generally be borrowed, and access to the remainder of this pocket thus gained. Datholite is also very characteristic in appearance, and can only be confounded with some forms of calcite occurring near it. It occurs in small glassy, nearly globular crystals; they are generally not over three-sixteenths of an inch in diameter, and generally pure and perfectly transparent, having a hardness of a little over 5, and specific gravity of 3; as it generally occurs as a druse upon the trap, or an apopholite, calcite, etc., this is seldom attainable, however, and we have a very distinctive characteristic in another test: this is the blowpipe, under which it at first intumesces and then fuses to a transparent globule, and the flame, after playing upon it, is of a deep green color. Nitric acid must be used to boil it up with, and with



it it may be readily gelatinized. This last test will seldom be necessary, however, and may be dispensed with if the hardness and blowpipe reactions may be ascertained.

*Apopholite.*--This beautiful mineral has been found in fair abundance at times in Shafts No. 1 and 2 in pockets, and seldom in place, most of it being taken from the loose stone at the mouth of the shaft, and it may generally be found on the dump. It is readily mistaken for calcite by the miners and those unskilled in mineralogy, but a drop of acid will quickly show the difference. The sizes of the crystals are very various, from an eighth of an inch long or thick, to, in one case, an inch and a half. The colors have been varied from white to nearly all tints, including pink, purple, blue, and green; the white variety is, however, the most abundant, and makes a handsome cabinet specimen. The crystals are generally packed together in a mass, but are frequently set apart as heavy druses of crystals having the form shown in Fig. 7. Sometimes, as in the former grouping, the crystals are without the pyramidal terminations, and are then right square prisms. The fracture being at perfect right angles, distinguishes it from calcite. Its hardness is generally fully 5, the specific gravity between 2.4 and 2.5; it is difficult to fuse before the blowpipe, but is finally fused into an opaque globule. Upon heating with nitric acid it partly dissolves, and the remainder becomes flaky and gelatinous. Apopholite, although quite rare, now may be bought from the men, or at least one of the engineers of Shaft No. 2's elevator, and generally at low terms.

*Phrenite.*--This mineral is quite abundant in Shafts No. 1 and 2, in very small masses, incrustations, and even in small crystals. It occurs embedded in or incrusting the trap, and also with calcite and apopholite. The only sure place to find it is at the southwest side of an opening through the pile of drift rock under the trestle work of the tramway, between shaft No. 1 and the dump, and within a few feet of a number of wooden vats sunk into the ground seen just before descending the hills and near the edge. Here on a number of blocks of trap it may be found, a greenish white incrustation about as thick as a knife blade; it also may be found on the main dump, and is sometimes found in plates one-eighth of an inch thick, of a darker green color, upon calcite. Its easiest distinguishment from the other minerals of this locality, with which it might be confounded, is its great hardness of from 6 to 7. It is very fragile and brittle, however, and is never perfectly transparent, but quite opaque; its specific gravity is 2.9, and it is readily fused before the blowpipe after intumescing. It partly dissolves in acid without gelatinizing, leaving a flaky residue; it is a beautiful mineral when in masses or crystals of a dark green color, but the best place in the vicinity to secure specimens of this kind is, as I will detail hereafter, at Paterson, N. J.

*Iron and Copper Pyrites.*--Both of these common but frequently beautiful minerals occur in the tunnel and adjacent rocks in great abundance. The crystals are generally about one-fourth of an inch in diameter, and groups of these may be frequently obtained on the dump in the shafts, especially No. 1 and 2, and where the rock is being cleared away for the eastern entrance to the tunnel. They resemble each other very much; the iron pyrites, however, is in cubical forms and having the great hardness of from 6 to 7, while the copper pyrites, less abundant and in forms having triangles for bases, but having sometimes other forms and a hardness of but 3 to 4. Both are similar in aspect to a piece of brass, and cannot be mistaken for any other mineral. The form of the copper pyrites is shown in Fig. 8; the iron is, as before noted, in cubes, more or less modified.

*Stilbite.*--Small quantities of this beautiful mineral have been found in Shaft No. 2, in a small bed of but a few square feet in area, but quite thick and appearing much like natrolite. This bed was about one hundred feet east from Shaft No. 2, and in the center of the heading when it was at that point. It has been encountered since in small quantities, and it would do well to look out for it in the fresh tunneled portion after the date appended to this paper. It generally occurs in the form shown in Fig. 9, grouped very similarly to natrolite, and being right upon the rock or a thin bed of itself. The crystals are generally half an inch long, but often less. The modifications of the above form, which are frequent in this species, strike one forcibly of the resemblance they bear to a broad stone spear head on a diminutive scale, with a blunted edge; their hardness is about 4, specific gravity 2.2, the color generally a pearly white or grayish. After a long boiling with nitric acid it gelatinizes, but it foams up and fuses to a transparent glass before the blowpipe. A little stilbite may often be found on the dumps.

*Laumonite* occurs in very small quantities on calcite or apopholite, and can hardly be expected to be found on the trip; but as it might be found, I will detail some of its characteristics. Hardness 4, specific gravity 2.3; it generally occurs in small crystals, but more frequently in a crumbly, chalky mass, which it becomes upon exposure to the air. The crystals are generally transparent and frequently tinged yellow in color. It gelatinizes by boiling with acid, and after intumescing before the blowpipe, fuses to a frothy mass. To keep this mineral when in crystals from crumbling upon exposure it may be dipped in a thin mastic varnish or in a gum-arabic solution.

*Heulandite*.--This rare mineral has been found under the same conditions as laumonite in Shaft No. 2, but it is seldom to be met with, and then in small crystals. It is of a pure white color, sometimes transparent. It intumesces and readily fuses before the blowpipe, and dissolves in acid without gelatinizing. Hardness 4, specific gravity 2.2.

The few other minerals occurring in the tunnel are so extremely rare as not to be met with by any other than an expert, and it is impossible to detail the localities, as they generally occur as minute druses or incrustations upon other minerals with which they may be confounded, and have been removed as soon as discovered. The minerals referred to are analcime, chabazite, Thompsonite, and finally, the mineral which I first found in this formation, Hayesine, which is extremely rare, and of which I only obtained sufficient to cover a square inch. The particulars in regard to its locality, etc., maybe found in the *American Journal of Sciences* for June, page 458. I will now sum up the characteristics of these several minerals of this locality in the table:

Name.	H.	Sp. Gr.	Action of Blowpipe.	Action of hot acid.	Color.	Appearance.
Calcite	3	2.6	Infusible, but glows	Soluble with effervescence	White	Like Fig. 3 and 4.
Natrolite	5	2.2	Readily fused to clear globule	Forms a jelly	do.	Like Fig 5.
Pectolite	4	2.5	do.	do. do.	do.	Divergent fibers, Fig. 6.
Datholite	5	3.0	Intumesces, fused to clear globule, gives green flame	Forms a jelly	Colorless white	Small, nearly spherical, etc.
Apopholite	5	2.5	Difficult, fused to opaque globule	Partly soluble in nitric acid	Tinted	Like Fig. 7.
Phrenite	6 to 7	2.9	Intomesces, fused to clear globule	Partly soluble in nitric acid, leaving flakes	Greenish	In tables and incrustations.
Iron pyrites	6 to 7	5.0	Burns and yields a black globule, decrepitates		Brass	Cubical.
Copper pyrites	3 to 4	4.2	do. do.		do.	Tetrahedral.
Stilbite	4	2.2	Intumesces and fuses readily	Difficult; jelly on long boiling with nitric acid.	White	Like Fig. 8.
Laumonite	4 to 0	2.3	Intumesces and fuses to frothy mass	Readily gelatinizes	do.	Generally chalky.
Heulandite	4	2.2	Intumesces and readily fuses	Soluble, no jelly	do.	In right rhomboidal prisms.

*To Distinguish the Minerals together the one from the other.*--Calcite by effervescing on placing a drop of acid upon it. Natrolite resembles stilbite, but may be distinguished by gelatinizing readily with hydrochloric acid and by not intumescing when heated before the blowpipe; from the other minerals by the form of the crystals and their setting, also the locality in the tunnel in which it was found.

Pectolite sometimes resembles some of the others, but may be readily distinguished by its *tough* long fibers, not brittle like natrolite. Datholite may generally be distinguished by the form of its crystals and their glassy appearance, with great hardness, and by tingeing the flame from the blowpipe of a true green color. Apopholite is distinguished from calcite, as noticed under that species, and from the others by its form, difficult fusibility, and part solubility.

Phrenite is characterized by its hardness, greenish color, occurrence, and action of acid. Iron pyrites is always known by its brassy metallic aspect and great hardness. Copper pyrites, by its aspect from the other minerals, and from iron pyrites by its

inferior hardness and less gravity.

Stilbite is characterized by its form, difficult gelatinizing, and intumescence before the blowpipe; from natrolite as mentioned under that species.

Laumonite is known by its generally chalky appearance and a probable failure in finding it.

Heulandite is distinguished from stilbite by its crystals and perfect solubility; from apopholite by form of crystals.

In the next part of this paper I will commence with Staten Island.

July 1, 1882. (*To be continued.*)

---

## ANTISEPTICS.

The author has endeavored to ascertain what agents are able to destroy the spores of bacilli, how they behave toward the microphytes most easily destroyed, such as the moulds, ferments, and micrococci, and if they suffice at least to arrest the development of these organisms in liquids favorable to their multiplication. His results with phenol, thymol, and salicylic acid have been unfavorable. Sulphurous acid and zinc chloride also failed to destroy all the germs of infection. Chlorine, bromine, and mercuric chloride gave the best results; solutions of mercuric chloride, nitrate, or sulphate diluted to 1 part in 1,000 destroy spores in ten minutes.--*R. Koch.*

---

## CRYSTALLIZATION AND ITS EFFECTS UPON IRON.

**By N.B. WOOD, Member of the Civil Engineers' Club, of Cleveland.**

[Footnote: Read January 10th. 1882.]

The question has been asked, "What is the chemically scientific definition of crystallization?" Now as the study of crystallization and its effect upon matter, physically as well as chemically, will be of interest, considering the subject matter for discussion, I shall not only endeavor to answer the question, as I understand it, but try to treat it somewhat technologically.

Having this object in view, I have prepared or brought about the conditions necessary to the formation of a few crystals of various chemical substances, which for various reasons, such as lack of time and bad weather, are not as perfect as could be desired, but will perhaps subserve the purpose for which they were designed. I think you will agree with me that they are beautiful, if they are imperfect, and I can assure you that the pleasure of watching their formation fully repays one for the trouble, if for no other reason than the mere gratification of the senses. From the earliest times and by all races of men, the crystal has been admired and imitated, or improved by cutting and polishing into faces of various substances. I have also procured specimens of steel and iron which show the effect of crystallization, which was produced (perhaps) under known conditions, so that the conclusions which we arrive at from their study will have a fair chance of being logical, at least, and perhaps of some practical value.

When we examine inanimate nature we find two grand divisions of matter, *fluid* and *solid*. These two divisions may be subdivided into, the former gaseous and liquid, the latter amorphous and crystalline; but whether one or the other of these divisions be considered, their ultimate and common division will be the ATOM. By the atom we understand that portion of matter which admits of no further division, which, though as inconceivable for minuteness as space is for extent, has still definite weight, form, and volume; which under favorable circumstances, has that power or force called cohesion, the intensity of which constitutes strength of material, which every engineer is supposed to understand, but which lies far beyond the powers of the human mind for comprehension or analysis. When we apply a magnet to a mass of iron filings, we observe the particles arrange themselves in regular order, having considerable strength in one direction, and very little or none in any other. Now, although we understand very little about the force which holds these particles in position, we do know that it is actual force applied from without and maintained at the expense of some of the known sources of force. But the force or power or property of cohesion seems to be a quality stored within the atom itself, in many cases similar to magnetism, having powerful attraction in some directions and very little or none in others. A crystal of mica, for instance, or gypsum may be divided to

any degree of thinness, but is very difficult to even break. This property of crystals is termed cleavage. Cohesion and crystallization are affected variously by various circumstances, such as heat or its absence, motion or its absence, etc. In fact, almost every phenomenon of nature within the range of ordinary temperatures has effects which may be favorable to the crystallization of some substances, and at the same time unfavorable to others; so it will be seen that it is impossible to lay down any rule for it except for named substances, like substances requiring like conditions, to bring its atoms into that state of equilibrium where crystallization can occur. If we examine crystals carefully we find, not only that nature has here provided geometric forms of marvelous beauty and exactness, with faces of polish and quoins of acuteness equal to the work of the most skillful lapidist, "but that in whatever manner or under whatever circumstances a crystal may have been formed, whether in the laboratory of the chemist or the workshop of nature, in the bodies of animals or the tissues of plants, up in the sky or in the depths of the earth, whether so rapidly that we may literally see its growth, or by the slow aggregation of its molecules during perhaps thousands of years, we always find that the arrangement of the faces is subject to fixed and definite laws." We find also that a crystal is always finished and has its form as perfectly developed when it is the minutest point discernible by the microscope as when it has attained its ultimate growth. I might add parenthetically that crystals are sometimes of immense size, one at Milan of quartz being 3 feet 3 inches long and 5 feet 6 inches in circumference, and is estimated to weigh over 800 pounds; and a gigantic beryl at Grafton, N. H., is over 4 feet in length and 32 inches in diameter, and weighs not less than 5,000 pounds; but the most perfect specimens are of small size, as some accident is sure to overtake the larger ones before they acquire their growth, to interfere with their symmetry or transparency. This you will see abundantly illustrated by the examples which I have prepared, as also the constancy of the angles of like faces. Chemically speaking, the crystal is always a perfect chemical body, and can never be a mechanical mixture. This fact has been of great value to the science of chemistry in developing the atomic theory, which has demonstrated that a body can only exist chemically combined when a definite number of atoms of each element is present, and that there is no certainty of such proportions existing except in the crystal. I hold before you a crystal of common alum. Its chemical symbol would be  $\text{Al}_2\text{O}_3, 3\text{SO}_3 + \text{K}_2\text{O}, \text{SO}_3 + 24\text{H}_2\text{O}$ . If we knew its weight and wished to know its ultimate component parts, we could calculate them more readily than we could acquire that knowledge by any other means. But the elements of this quantity of uncrystallized alum could not be computed. Then we may define crystallization to be the operation of nature wherein the chemical atoms or molecules of a substance have sufficient polarized force to arrange themselves about a central attracting point in definite geometrical forms.

Fresenius defines it thus: "*Every operation, or process, whereby bodies are made to pass from the fluid to the solid state, and to assume certain fixed, mathematically definable, regular forms.*" It would be folly for me to attempt to criticise Fresenius, but I give you both definitions, and you can take your choice. The definition of Fresenius, however, will not suit our present purpose, because the crystallization of wrought iron occurs, or seems to, *after* the iron has acquired a *solid state*.

Iron, as you all know, is known to the arts in three forms: cast or crude, steel, and wrought or malleable. Cast iron varies much in chemical composition, being a mixture of iron and carbon chiefly, as constant factors, with which silicium in small quantities (from 1 to 5 per cent.), phosphorus, sulphur, and sometimes manganese (e.g. spiegeleisen) and various other elements are combined. All of these have some effect upon the crystalline structure of the mass, but whatever crystallization takes place occurs at the moment of solidification, or between that and a red heat, and varies much, according to the time occupied in cooling, as to its composition. My own experience leads me to think that a cast iron having about 3 per cent. of carbon, a small per centage of phosphorus, say about  $\frac{1}{2}$  of 1 per cent., and very small quantities of silicium, the less the better, and traces of manganese (the two latter substances *slagging* out almost entirely during the process of remelting for casting), makes a metal best adapted to the general use of the founder. Such proportions will make a soft, even grained, dark gray iron, whose crystals are small and bright, and whose fracture will be uneven and sharp to the touch. The phosphorus in this instance gives the metal liquidity at a low temperature, but does not seem to influence the crystallization to any appreciable extent. The two elements to be avoided by the founder are silicium and sulphur. These give to iron a peculiar crystalline appearance easily recognized by an experienced person. Silicium seems to obliterate the sparkling brilliancy of the crystalline faces of good iron, and replace them with very fine dull ones only discernible with a lens, and the iron breaks more like stoneware than metal, while sulphur in appreciable quantities gives a striated crystalline texture similar to chilled iron, and very brittle. Phosphorus in very large quantities acts similarly. The form of the crystal in cast iron is the octahedron, so that right angles with sharp corners should be avoided as much as possible in castings, as the most likely position for a crystal to take would be with its faces along the line of the angle. Steel, to be of any value as such, *must* be made of the purest material. Phosphorus and sulphur *must* not exist, except in the most minute

quantities, or the metal is worthless. If either of these substances be present in a bar of steel, its structure will be coarse, crystalline and weak. The reason of this is unknown, but probably their presence reduces the power of cohesion; and, that being reduced, gives the molecules of steel greater freedom to arrange themselves in conformity with their polarity, and this in its turn again weakens the mass by the tendency of the crystals to cleavage in certain directions. Carbon is a constant element in steel, as it is in cast iron, but is frequently replaced by chromium, titanium, etc., or is said to be, though it is not quite clear to me how it can be so if steel is a chemical compound. However this may be, we know that a piece of good soft steel breaks with a fine crystalline fracture, and the same piece hardened when broken shows either an amorphous structure or one very finely crystalline, which would indicate that the crystals had been broken up by the action of heat, and that they had not had sufficient time to return to their original position on account of the sudden cooling. The tendency of the molecules of steel after hardening to assume their natural position when cold seems to be very great, for we have often seen large pieces of steel burst asunder after hardening, though lying untouched, and sometimes with such force as to hurl the fragments to some distance. If a piece of steel be subjected to a bright yellow or white heat its nature is entirely changed, and the workman says it is burnt. Though this is not actually a fact, it does well enough to express that condition of the metal. Steel cannot be burnt unless some portion of it has been oxidized. The carbon would of course be attacked first, its affinity for oxygen being greatest; but we find nothing wanting in a piece of burnt steel. It can, by careful heating, hammering and hardening, be returned to its former excellence. Then what change has taken place? I should say that two modifications have been made, one physical, the other chemical. The change chemically is that of a chemical compound to a mixture of carbon and iron, so that in a chemical sense it resembles cast iron. The change physically is that of crystallization, being due partly to chemical change and partly to the effect of heat. I have procured a specimen of steel showing beautifully the effect of overheating. The specimen is labeled No. 1, and is a piece of Park Brothers' steel (one of the best brands made in America). It has been heated at one end to proper heat for hardening, and at the other is what is technically called "burnt." It has been broken at intervals of about 1½ inches, showing the transition from amorphous or proper hardening to highly crystalline or "burnt." Malleable or wrought iron is or should be pure iron. Of course in practice it is seldom such, but generally nearly so, being usually 98, 99, or even more per cent. It is exceedingly prone to crystallization, the purer varieties being as much subject to it as others, except those contaminated with phosphorus, which affects it similarly with steel, and makes it very weak to cross and tensile strains. I have never estimated the quantity present in any except one specimen, a bar of 1½ round, which literally fell to pieces when dropped across a block of iron. It had 1.32 per cent. of phosphorus and was very crystalline, though the crystals were not very large. Iron which has been, when first made, quite fibrous, when subjected to a series of shocks for a greater or less period, according to their intensity, when subjected to intense currents of electricity, or when subjected to high temperatures, or has by mechanical force been pushed together, or, as it is called, upset, becomes extremely crystalline. Under all of these circumstances it is subjected to one physical phenomenon, that of motion. It would seem that if a bar of iron were struck, the blow would shake the whole mass, and consequently the relative position of the particles remain unchanged, but this is not the case. When the blow is struck it takes an appreciable length of time for the effect to be communicated to the other end so as to be heard, if the distance is great. This shows that a small force is communicated from particle to particle independently along the whole mass, and that each atom actually moves independently of its neighbor. Then, if there be any attraction at the time tending to arrange it differently, it will conform to it. So much for theory with regard to this important matter. It looks well on paper, but do the facts of the case correspond? If practically demonstrated and systematically executed, experiments fail to corroborate the theory, and if, furthermore, we find there is no necessity for the theory, we naturally conclude that it is all wrong, or, at least, imperfectly understood. Now there is one other quality imparted to iron by successive shocks, which, I think, is independent of crystallization, and this quality is hardness and consequent brittleness. One noticeable feature about this also is, that as "absolute cohesion" or tensile strength diminishes, "relative cohesion" or strength to resist crushing increases. Specimens Nos. 2, 3, and 4 are pieces of Swedish iron, probably from the celebrated mines of Dannemora. Nos. 2 and 3 are parts of the same bolt, which, after some months' use on a "heading machine" in a bolt and nut works, where it was subjected to numerous and violent shocks, (perhaps 50,000 or 60,000 per day), it broke short off, as you see in No 2, showing a highly crystalline fracture. To test whether this structure continued through the bolt, I had it nicked by a blacksmith's cold chisel and broken. The specimen shows that it is still stronger at that point than at the point where it is actually broken, but the resulting fracture shows the same crystalline appearance. I next had specimen No. 4 cut from a fresh bar of iron which had never been used for anything. It also shows a crystalline fracture, indicating that this peculiarity had existed in the iron of both from the beginning.

I next took specimen No. 3 and subjected it to a careful annealing, taking perhaps two hours in the operation. Although it is a 1-1/8 bolt and has V threads cut upon it we were unable to break it, although bent cold through an arc of 90°, and probably would have doubled upon itself if we had had the means to have forced it. Now what does this show? Have the crystals been obliterated by the process of annealing, or has only their cleavage been destroyed, so that when they break, instead of showing brilliant, sparkling faces, they are drawn into a fibrous looking mass? The latter seems to be the most plausible theory, to which I admit objections may be raised. For my own part, I am inclined to the belief that the crystal exists in all iron which is finished above a bright red heat, and that between that and black heat they are formed and have whatever characteristics circumstances may confer upon them, modified by the action of agencies heretofore mentioned.

---

A catalogue, containing brief notices of many important scientific papers heretofore published in the SUPPLEMENT, may be had gratis at this office.

---

## **THE SCIENTIFIC AMERICAN SUPPLEMENT.**

**PUBLISHED WEEKLY.**

### **Terms of Subscription, \$5 a Year.**

Sent by mail, postage prepaid, to subscribers in any part of the United States or Canada. Six dollars a year, sent, prepaid, to any foreign country.

All the back numbers of THE SUPPLEMENT, from the commencement, January 1, 1876, can be had. Price, 10 cents each.

All the back volumes of THE SUPPLEMENT can likewise be supplied. Two volumes are issued yearly. Price of each volume, \$2.50, stitched in paper, or \$3.50, bound in stiff covers.

COMBINED RATES--One copy of SCIENTIFIC AMERICAN and one copy of SCIENTIFIC AMERICAN SUPPLEMENT, one year, postpaid, \$7.00.

A liberal discount to booksellers, news agents, and canvassers.

**MUNN & CO., Publishers,**

**261 Broadway, New York, N. Y.**

---

## **PATENTS.**

In connection with the **Scientific American**, Messrs. MUNN & Co. are Solicitors of American and Foreign Patents, have had 35 years' experience, and now have the largest establishment in the world. Patents are obtained on the best terms.

A special notice is made in the **Scientific American** of all Inventions patented through this Agency, with the name and residence of the Patentee. By the immense circulation thus given, public attention is directed to the merits of the new patent, and sales or introduction often easily effected.

Any person who has made a new discovery or invention can ascertain, free of charge, whether a patent can probably be obtained, by writing to MUNN & Co.

We also send free our Hand Book about the Patent Laws, Patents, Caveats. Trade Marks, their costs, and how procured, with hints for procuring advances on inventions. Address

**MUNN & CO., 261 Broadway, New York.**

Branch Office, cor. F and 7th Sts., Washington, D. C.

\*\*\* END OF THE PROJECT GUTENBERG EBOOK SCIENTIFIC AMERICAN  
SUPPLEMENT, NO. 344, AUGUST 5, 1882 \*\*\*

Updated editions will replace the previous one—the old editions will be renamed.

Creating the works from print editions not protected by U.S. copyright law means that no one owns a United States copyright in these works, so the

Foundation (and you!) can copy and distribute it in the United States without permission and without paying copyright royalties. Special rules, set forth in the General Terms of Use part of this license, apply to copying and distributing Project Gutenberg™ electronic works to protect the PROJECT GUTENBERG™ concept and trademark. Project Gutenberg is a registered trademark, and may not be used if you charge for an eBook, except by following the terms of the trademark license, including paying royalties for use of the Project Gutenberg trademark. If you do not charge anything for copies of this eBook, complying with the trademark license is very easy. You may use this eBook for nearly any purpose such as creation of derivative works, reports, performances and research. Project Gutenberg eBooks may be modified and printed and given away—you may do practically ANYTHING in the United States with eBooks not protected by U.S. copyright law. Redistribution is subject to the trademark license, especially commercial redistribution.

START: FULL LICENSE  
THE FULL PROJECT GUTENBERG LICENSE  
PLEASE READ THIS BEFORE YOU DISTRIBUTE OR USE THIS WORK

To protect the Project Gutenberg™ mission of promoting the free distribution of electronic works, by using or distributing this work (or any other work associated in any way with the phrase “Project Gutenberg”), you agree to comply with all the terms of the Full Project Gutenberg™ License available with this file or online at [www.gutenberg.org/license](http://www.gutenberg.org/license).

**Section 1. General Terms of Use and Redistributing Project Gutenberg™ electronic works**

1.A. By reading or using any part of this Project Gutenberg™ electronic work, you indicate that you have read, understand, agree to and accept all the terms of this license and intellectual property (trademark/copyright) agreement. If you do not agree to abide by all the terms of this agreement, you must cease using and return or destroy all copies of Project Gutenberg™ electronic works in your possession. If you paid a fee for obtaining a copy of or access to a Project Gutenberg™ electronic work and you do not agree to be bound by the terms of this agreement, you may obtain a refund from the person or entity to whom you paid the fee as set forth in paragraph 1.E.8.

1.B. “Project Gutenberg” is a registered trademark. It may only be used on or associated in any way with an electronic work by people who agree to be bound by the terms of this agreement. There are a few things that you can do with most Project Gutenberg™ electronic works even without complying with the full terms of this agreement. See paragraph 1.C below. There are a lot of things you can do with Project Gutenberg™ electronic works if you follow the terms of this agreement and help preserve free future access to Project Gutenberg™ electronic works. See paragraph 1.E below.

1.C. The Project Gutenberg Literary Archive Foundation (“the Foundation” or PGLAF), owns a compilation copyright in the collection of Project Gutenberg™ electronic works. Nearly all the individual works in the collection are in the public domain in the United States. If an individual work is unprotected by copyright law in the United States and you are located in the United States, we do not claim a right to prevent you from copying, distributing, performing, displaying or creating derivative works based on the work as long as all references to Project Gutenberg are removed. Of course, we hope that you will support the Project Gutenberg™ mission of promoting free access to electronic works by freely sharing Project Gutenberg™ works in compliance with the terms of this agreement for keeping the Project Gutenberg™ name associated with the work. You can easily comply with the terms of this agreement by keeping this work in the same format with its attached full Project Gutenberg™ License when you share it without charge with others.

1.D. The copyright laws of the place where you are located also govern what you can do with this work. Copyright laws in most countries are in a constant state of change. If you are outside the United States, check the laws of your country in addition to the terms of this agreement before downloading, copying, displaying, performing, distributing or creating derivative works based on this work or any other Project Gutenberg™ work. The Foundation makes no representations concerning the copyright status of any work in any country other than the United States.

1.E. Unless you have removed all references to Project Gutenberg:

1.E.1. The following sentence, with active links to, or other immediate access to, the full Project Gutenberg™ License must appear prominently whenever any

copy of a Project Gutenberg™ work (any work on which the phrase “Project Gutenberg” appears, or with which the phrase “Project Gutenberg” is associated) is accessed, displayed, performed, viewed, copied or distributed:

This eBook is for the use of anyone anywhere in the United States and most other parts of the world at no cost and with almost no restrictions whatsoever. You may copy it, give it away or re-use it under the terms of the Project Gutenberg License included with this eBook or online at [www.gutenberg.org](http://www.gutenberg.org). If you are not located in the United States, you will have to check the laws of the country where you are located before using this eBook.

1.E.2. If an individual Project Gutenberg™ electronic work is derived from texts not protected by U.S. copyright law (does not contain a notice indicating that it is posted with permission of the copyright holder), the work can be copied and distributed to anyone in the United States without paying any fees or charges. If you are redistributing or providing access to a work with the phrase “Project Gutenberg” associated with or appearing on the work, you must comply either with the requirements of paragraphs 1.E.1 through 1.E.7 or obtain permission for the use of the work and the Project Gutenberg™ trademark as set forth in paragraphs 1.E.8 or 1.E.9.

1.E.3. If an individual Project Gutenberg™ electronic work is posted with the permission of the copyright holder, your use and distribution must comply with both paragraphs 1.E.1 through 1.E.7 and any additional terms imposed by the copyright holder. Additional terms will be linked to the Project Gutenberg™ License for all works posted with the permission of the copyright holder found at the beginning of this work.

1.E.4. Do not unlink or detach or remove the full Project Gutenberg™ License terms from this work, or any files containing a part of this work or any other work associated with Project Gutenberg™.

1.E.5. Do not copy, display, perform, distribute or redistribute this electronic work, or any part of this electronic work, without prominently displaying the sentence set forth in paragraph 1.E.1 with active links or immediate access to the full terms of the Project Gutenberg™ License.

1.E.6. You may convert to and distribute this work in any binary, compressed, marked up, nonproprietary or proprietary form, including any word processing or hypertext form. However, if you provide access to or distribute copies of a Project Gutenberg™ work in a format other than “Plain Vanilla ASCII” or other format used in the official version posted on the official Project Gutenberg™ website ([www.gutenberg.org](http://www.gutenberg.org)), you must, at no additional cost, fee or expense to the user, provide a copy, a means of exporting a copy, or a means of obtaining a copy upon request, of the work in its original “Plain Vanilla ASCII” or other form. Any alternate format must include the full Project Gutenberg™ License as specified in paragraph 1.E.1.

1.E.7. Do not charge a fee for access to, viewing, displaying, performing, copying or distributing any Project Gutenberg™ works unless you comply with paragraph 1.E.8 or 1.E.9.

1.E.8. You may charge a reasonable fee for copies of or providing access to or distributing Project Gutenberg™ electronic works provided that:

- You pay a royalty fee of 20% of the gross profits you derive from the use of Project Gutenberg™ works calculated using the method you already use to calculate your applicable taxes. The fee is owed to the owner of the Project Gutenberg™ trademark, but he has agreed to donate royalties under this paragraph to the Project Gutenberg Literary Archive Foundation. Royalty payments must be paid within 60 days following each date on which you prepare (or are legally required to prepare) your periodic tax returns. Royalty payments should be clearly marked as such and sent to the Project Gutenberg Literary Archive Foundation at the address specified in Section 4, “Information about donations to the Project Gutenberg Literary Archive Foundation.”
- You provide a full refund of any money paid by a user who notifies you in writing (or by e-mail) within 30 days of receipt that s/he does not agree to the terms of the full Project Gutenberg™ License. You must require such a user to return or destroy all copies of the works possessed in a physical medium and discontinue all use of and all access to other copies of Project Gutenberg™ works.
- You provide, in accordance with paragraph 1.F.3, a full refund of any money paid for a work or a replacement copy, if a defect in the electronic work is



discovered and reported to you within 90 days of receipt of the work.

- You comply with all other terms of this agreement for free distribution of Project Gutenberg™ works.

1.E.9. If you wish to charge a fee or distribute a Project Gutenberg™ electronic work or group of works on different terms than are set forth in this agreement, you must obtain permission in writing from the Project Gutenberg Literary Archive Foundation, the manager of the Project Gutenberg™ trademark. Contact the Foundation as set forth in Section 3 below.

1.F.

1.F.1. Project Gutenberg volunteers and employees expend considerable effort to identify, do copyright research on, transcribe and proofread works not protected by U.S. copyright law in creating the Project Gutenberg™ collection. Despite these efforts, Project Gutenberg™ electronic works, and the medium on which they may be stored, may contain “Defects,” such as, but not limited to, incomplete, inaccurate or corrupt data, transcription errors, a copyright or other intellectual property infringement, a defective or damaged disk or other medium, a computer virus, or computer codes that damage or cannot be read by your equipment.

1.F.2. LIMITED WARRANTY, DISCLAIMER OF DAMAGES - Except for the “Right of Replacement or Refund” described in paragraph 1.F.3, the Project Gutenberg Literary Archive Foundation, the owner of the Project Gutenberg™ trademark, and any other party distributing a Project Gutenberg™ electronic work under this agreement, disclaim all liability to you for damages, costs and expenses, including legal fees. YOU AGREE THAT YOU HAVE NO REMEDIES FOR NEGLIGENCE, STRICT LIABILITY, BREACH OF WARRANTY OR BREACH OF CONTRACT EXCEPT THOSE PROVIDED IN PARAGRAPH 1.F.3. YOU AGREE THAT THE FOUNDATION, THE TRADEMARK OWNER, AND ANY DISTRIBUTOR UNDER THIS AGREEMENT WILL NOT BE LIABLE TO YOU FOR ACTUAL, DIRECT, INDIRECT, CONSEQUENTIAL, PUNITIVE OR INCIDENTAL DAMAGES EVEN IF YOU GIVE NOTICE OF THE POSSIBILITY OF SUCH DAMAGE.

1.F.3. LIMITED RIGHT OF REPLACEMENT OR REFUND - If you discover a defect in this electronic work within 90 days of receiving it, you can receive a refund of the money (if any) you paid for it by sending a written explanation to the person you received the work from. If you received the work on a physical medium, you must return the medium with your written explanation. The person or entity that provided you with the defective work may elect to provide a replacement copy in lieu of a refund. If you received the work electronically, the person or entity providing it to you may choose to give you a second opportunity to receive the work electronically in lieu of a refund. If the second copy is also defective, you may demand a refund in writing without further opportunities to fix the problem.

1.F.4. Except for the limited right of replacement or refund set forth in paragraph 1.F.3, this work is provided to you ‘AS-IS’, WITH NO OTHER WARRANTIES OF ANY KIND, EXPRESS OR IMPLIED, INCLUDING BUT NOT LIMITED TO WARRANTIES OF MERCHANTABILITY OR FITNESS FOR ANY PURPOSE.

1.F.5. Some states do not allow disclaimers of certain implied warranties or the exclusion or limitation of certain types of damages. If any disclaimer or limitation set forth in this agreement violates the law of the state applicable to this agreement, the agreement shall be interpreted to make the maximum disclaimer or limitation permitted by the applicable state law. The invalidity or unenforceability of any provision of this agreement shall not void the remaining provisions.

1.F.6. INDEMNITY - You agree to indemnify and hold the Foundation, the trademark owner, any agent or employee of the Foundation, anyone providing copies of Project Gutenberg™ electronic works in accordance with this agreement, and any volunteers associated with the production, promotion and distribution of Project Gutenberg™ electronic works, harmless from all liability, costs and expenses, including legal fees, that arise directly or indirectly from any of the following which you do or cause to occur: (a) distribution of this or any Project Gutenberg™ work, (b) alteration, modification, or additions or deletions to any Project Gutenberg™ work, and (c) any Defect you cause.

## **Section 2. Information about the Mission of Project Gutenberg™**

Project Gutenberg™ is synonymous with the free distribution of electronic works in formats readable by the widest variety of computers including obsolete, old,

middle-aged and new computers. It exists because of the efforts of hundreds of volunteers and donations from people in all walks of life.

Volunteers and financial support to provide volunteers with the assistance they need are critical to reaching Project Gutenberg™'s goals and ensuring that the Project Gutenberg™ collection will remain freely available for generations to come. In 2001, the Project Gutenberg Literary Archive Foundation was created to provide a secure and permanent future for Project Gutenberg™ and future generations. To learn more about the Project Gutenberg Literary Archive Foundation and how your efforts and donations can help, see Sections 3 and 4 and the Foundation information page at [www.gutenberg.org](http://www.gutenberg.org).

### **Section 3. Information about the Project Gutenberg Literary Archive Foundation**

The Project Gutenberg Literary Archive Foundation is a non-profit 501(c)(3) educational corporation organized under the laws of the state of Mississippi and granted tax exempt status by the Internal Revenue Service. The Foundation's EIN or federal tax identification number is 64-6221541. Contributions to the Project Gutenberg Literary Archive Foundation are tax deductible to the full extent permitted by U.S. federal laws and your state's laws.

The Foundation's business office is located at 809 North 1500 West, Salt Lake City, UT 84116, (801) 596-1887. Email contact links and up to date contact information can be found at the Foundation's website and official page at [www.gutenberg.org/contact](http://www.gutenberg.org/contact)

### **Section 4. Information about Donations to the Project Gutenberg Literary Archive Foundation**

Project Gutenberg™ depends upon and cannot survive without widespread public support and donations to carry out its mission of increasing the number of public domain and licensed works that can be freely distributed in machine-readable form accessible by the widest array of equipment including outdated equipment. Many small donations (\$1 to \$5,000) are particularly important to maintaining tax exempt status with the IRS.

The Foundation is committed to complying with the laws regulating charities and charitable donations in all 50 states of the United States. Compliance requirements are not uniform and it takes a considerable effort, much paperwork and many fees to meet and keep up with these requirements. We do not solicit donations in locations where we have not received written confirmation of compliance. To SEND DONATIONS or determine the status of compliance for any particular state visit [www.gutenberg.org/donate](http://www.gutenberg.org/donate).

While we cannot and do not solicit contributions from states where we have not met the solicitation requirements, we know of no prohibition against accepting unsolicited donations from donors in such states who approach us with offers to donate.

International donations are gratefully accepted, but we cannot make any statements concerning tax treatment of donations received from outside the United States. U.S. laws alone swamp our small staff.

Please check the Project Gutenberg web pages for current donation methods and addresses. Donations are accepted in a number of other ways including checks, online payments and credit card donations. To donate, please visit: [www.gutenberg.org/donate](http://www.gutenberg.org/donate)

### **Section 5. General Information About Project Gutenberg™ electronic works**

Professor Michael S. Hart was the originator of the Project Gutenberg™ concept of a library of electronic works that could be freely shared with anyone. For forty years, he produced and distributed Project Gutenberg™ eBooks with only a loose network of volunteer support.

Project Gutenberg™ eBooks are often created from several printed editions, all of which are confirmed as not protected by copyright in the U.S. unless a copyright notice is included. Thus, we do not necessarily keep eBooks in compliance with any particular paper edition.

Most people start at our website which has the main PG search facility: [www.gutenberg.org](http://www.gutenberg.org).

This website includes information about Project Gutenberg™, including how to make donations to the Project Gutenberg Literary Archive Foundation, how to help produce our new eBooks, and how to subscribe to our email newsletter to hear about new eBooks.